



TEST REPORT

Applicant Name & Address : Foshan Shunde YA-IN Electric Appliance Manufacture Co., Ltd
No. 8 Longxiao Road. Longyongkou, Ronggui Town, Shunde, Foshan
Guangdong 528305 China

Manufacturing Site : Same as applicant

Sample Description

Product : Induction Cooktop
Model No. : C74E-AABC02, C74E-AABC03
Electrical Rating : AC 240V~ 60Hz, 7400W
FCC ID : ZFB-C74E-AABC02

Date Received : 7 August 2016

Date Test Conducted : 7 August 2016 – 20 September 2016

Test standards : **FCC Part 18: 2014**

Test Result : Pass

Conclusion : The submitted samples complied with the above rules/standards.

Remark : None.

*****End of Page*****

Prepared and Checked By:



Leo Luo
Engineer
Intertek Guangzhou

Approved By:

 *Signature*

Helen Ma
Team Leader
Intertek Guangzhou

29 September 2016 *Date*

This report is for the exclusive use of Intertek's Client and is provided pursuant to the agreement between Intertek and its Client. Intertek's responsibility and liability are limited to the terms and conditions of the agreement. Intertek assumes no liability to any party, other than to the Client in accordance with the agreement, for any loss, expense or damage occasioned by the use of this report. Only the Client is authorized to permit copying or distribution of this report and then only in its entirety. Any use of the Intertek name or one of its marks for the sale or advertisement of the tested material, product or service must first be approved in writing by Intertek. The observations and test results in this report are relevant only to the sample tested. This report by itself does not imply that the material, product, or service is or has ever been under an Intertek certification program. The test report only allows to be revised within three years from its original issued date unless further standard or the requirement was noticed.

Intertek Testing Services Shenzhen Ltd. Guangzhou Branch
Block E, No.7-2 Guang Dong Software Science Park, Caipin Road, Guangzhou Science City, GETDD Guangzhou, China
Tel / Fax: 86-20-8213 9688/86-20-3205 7538
© 2016 Intertek

CONTENT

TEST REPORT 1

CONTENT 2

1 TEST RESULTS SUMMARY 3

2 TEST RESULTS CONCLUSION 4

3 LABORATORY MEASUREMENTS 5

4 TEST CONFIGURATION..... 6

5 TEST RESULTS 6

5.1 CONDUCTED EMISSION TEST 6

5.1.1 *Used Test Equipment* 6

5.1.2 *Block Diagram of Test Setup* 7

5.1.3 *Test Setup and Procedure* 7

5.1.4 *Test Data & Curve*..... 8

5.1.5 *Measurement Uncertainty* 14

5.2 RADIATED EMISSION(9KHZ - 30 MHZ)..... 14

5.2.1 *Used Test Equipment* 14

5.2.2 *Block Diagram of Test Setup* 14

5.2.3 *Test Setup and Procedure*..... 15

5.2.4 *Test Data & Curve*..... 16

5.2.5 *Measurement uncertainty* 22

5.3 RADIATED EMISSION (30 MHZ- 1 GHZ) 22

5.3.1 *Used Test Equipment* 22

5.3.2 *Block Diagram of Test Setup* 23

5.3.3 *Test Setup and Procedure*..... 23

5.3.4 *Test Data & Curve*..... 24

5.3.5 *Measurement uncertainty* 29

1

TEST RESULTS SUMMARY

Test Item	Standard	Result
Conducted Emission (9 kHz-30 MHz)	FCC Part 18: 2014	Pass
Radiated Emission (9 kHz-30 MHz)	FCC Part 18: 2014	Pass
Radiated Emission (30 MHz-1 GHz)	FCC Part 18: 2014	Pass
Radiated Emission (above 1 GHz)	FCC Part 18: 2014	N/A

Remark: 1. The symbol “N/A” in above table means Not Applicable.

2. When determining the test results, measurement uncertainty of tests has been considered.

2

Test Results Conclusion
(with Justification)

RE: EMC Testing Pursuant to FCC Part 18 performed on the Induction Cooktop, Models: C74E-AABC02, C74E-AABC03.

We tested the Induction Cooktop, Model: C74E-AABC02, C74E-AABC03, to determine if they were in compliance with the relevant FCC rules as marked on the Test Results Summary. We found that the units met the requirement of FCC Part 18 when tested as received. The worst case's test data was presented in this test report.

The submitted samples C74E-AABC02, C74E-AABC03 are Induction Hotplates for household use.

Model C74E-AABC02, C74E-AABC03 are the same except the model name.

According to above information, all the tests are performed on C74E-AABC02.

Conclusion:

The sample as received complied with the FCC Part 18 requirement.

The production units are required to conform to the initial sample as received when the units are placed on the market.



3 LABORATORY MEASUREMENTS

Configuration Information

Equipment Under Test (EUT):	Induction Cooktop
Model:	C74E-AABC02
Serial No.:	Not Labeled
Support Equipment:	N/A
Rated Voltage:	AC 240V~ 60Hz,
Condition of Environment:	Temperature : 22~28°C Relative Humidity: 35~60% Atmosphere Pressure 86~106kPa

Notes:

1. The EMI measurements had been made in the operating mode producing the largest emission in the frequency band being investigated consistent with normal applications.

An attempt had been made to maximize the emission by varying the configuration of the EUT.

2. Test Sites:

All of the tests are performed at:

Guangdong CIQ Technology Center.

No.3, Desheng East Road, Shunde Daliang, Foshan, Guangdong, China.

This test facility and site measurement data have been fully placed on file with the FCC, test firm registration number is 756674.

4 Test Configuration

Cooking Vessel (provided by manufacturer):
 Fill container with 80% of water.
 Material: stainless steel
 Contact surface diameter 18cm, Top surface diameter 23cm

The equipment under test (EUT) was configured to measure its highest possible radiation level. The test modes were adapted accordingly in reference to the instructions for use.

Test the EUT in the lowest power level, middle level and the highest power level, the worst test data was presented in the report.

5 TEST RESULTS

5.1 Conducted Emission Test

Test Result: Pass

5.1.1 Used Test Equipment

The middle power mode and the lowest power were conducted on below Equipment:

Equipment No.	Equipment	Model	Manufacturer	Last Cal.	Due Date
CQCSC-EMC-001	Shielded Room	TDK	8*6*4	2016/03/17	2019/03/17
CQCSC-EMC-002	EMI Test receiver	R&S	ESU8	2016/03/17	2017/03/17
CQCSC-EMC-007	LISN	R&S	ESH2-Z5	2016/03/17	2017/03/17
CQCSC-EMC-010	Shielded Room	TDK	8*6*4	2016/03/17	2019/03/17
CQCSC-EMC-052	LISN	R&S	ENV216	2015/12/11	2016/12/11

The highest power were conducted on below Equipment:

Equipment No.	Equipment	Model	Manufacturer	Last Cal.	Due Date
SD00781	EMI receiver	SMR4503	SCHAFNER	2016.8.31	2017.8.30
201044CK0121	LISN	ESH2-Z5	Rohde & Schwarz	2016.8.31	2017.8.30
1244BK0003SD	10dB Pulse Limiter	PLA-10N	Compliance Direction Systems Inc.	2016.8.31	2017.8.30
201044CK0128-1	shielding room	NP-HJ2	Changzhou Nanping	2016.1.12	2017.1.11

5.1.2 Block Diagram of Test Setup

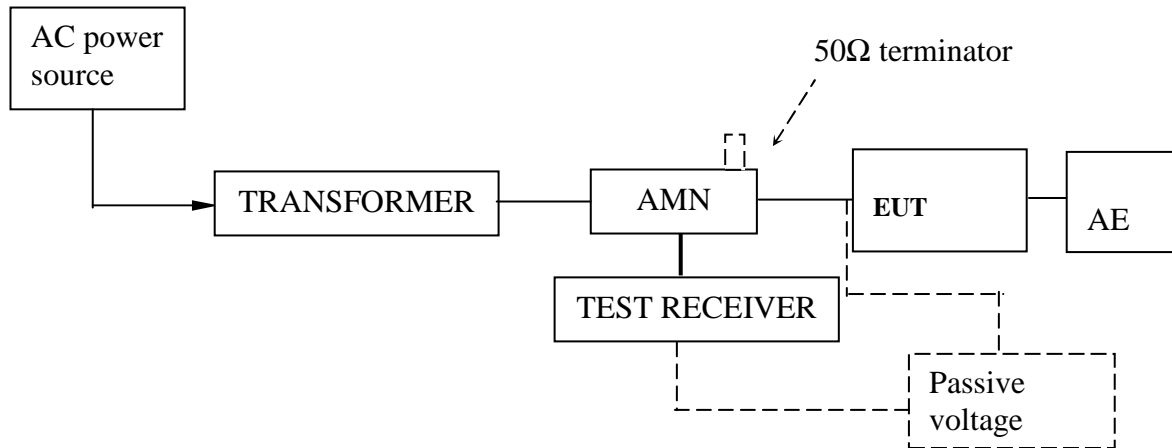

5.1.3 Test Setup and Procedure

Test was performed according to FCC OST/ MP-5:1986. The EUT was set to achieve the maximum emission level. The mains terminal disturbance voltage was measured with the EUT in a shielded room. The EUT was connected to AC power source through an Artificial Mains Network which provides a 50Ω linear impedance. Artificial hand is used if appropriate (for handheld apparatus). The load/control terminal disturbance voltage was measured with passive voltage probe if appropriate.

The table-top EUT was placed on a 0.8m high non-metallic table above earthed ground plane (Ground Reference Plane). And for floor standing EUT, was placed on a 0.1m high non-metallic supported on GRP. The EUT keeps a distance of at least 0.8m from any other of the metallic surface. The Artificial Mains Network is situated at a distance of 0.8m from the EUT.

During the test, mains lead of EUT excess 0.8m was folded back and forth parallel to the lead so as to form a horizontal bundle with a length between 0.3m and 0.4m.

The bandwidth of test receiver was set at 9 kHz. The frequency range from 9 kHz to 30MHz was checked.



5.1.4 Test Data & Curve

At main terminal: Pass

Tested Wire: Live

Operation Mode: the highest power

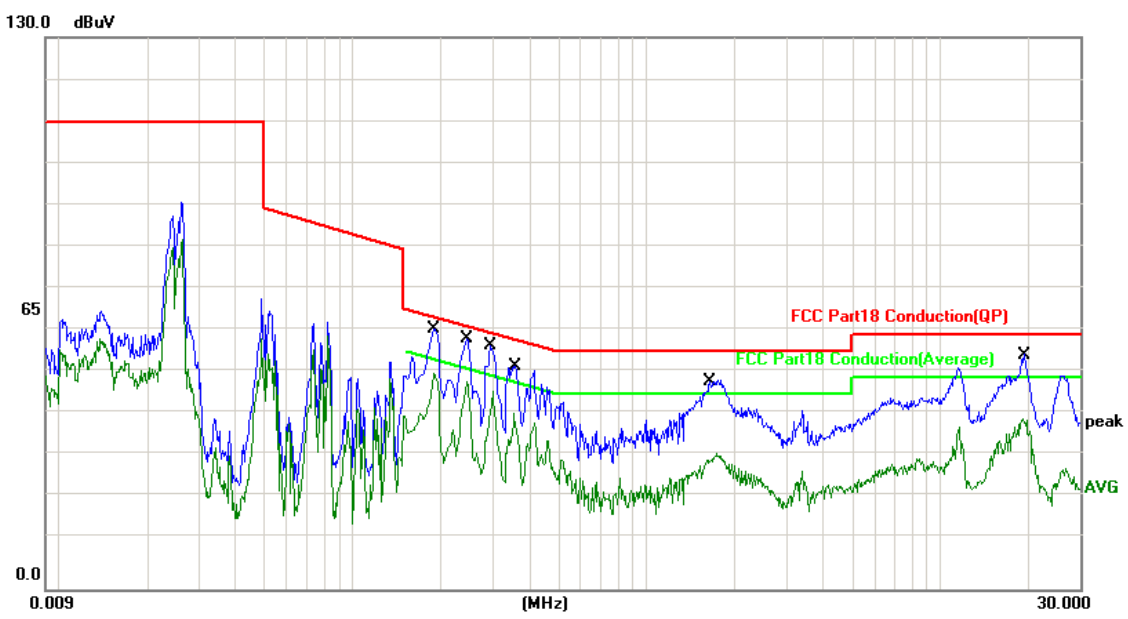

No.	Frequency (MHz)	Factor (dB)	Reading (dBuV)	Level (dBuV)	Limit (dBuV)	Margin (dB)	Detector	P/F
1	0.1900	10.00	48.10	58.10	64.03	-5.93	QP	P
2	0.1900	10.00	42.40	52.40	54.03	-1.63	AVG	P
3	0.2450	10.01	47.20	57.21	61.92	-4.71	QP	P
4	0.2450	10.01	40.00	50.01	51.92	-1.91	AVG	P
5	0.2949	10.01	45.10	55.11	60.38	-5.27	QP	P
6	0.2949	10.01	36.00	46.01	50.38	-4.37	AVG	P
7	0.3600	10.01	39.90	49.91	58.73	-8.82	QP	P
8	0.3600	10.01	28.40	38.41	48.73	-10.32	AVG	P
9	1.6150	10.05	34.60	44.65	56.00	-11.35	QP	P
10	1.6150	10.05	20.70	30.75	46.00	-15.25	AVG	P
11	19.4000	10.29	39.40	49.69	60.00	-10.31	QP	P
12	19.4000	10.29	29.50	39.79	50.00	-10.21	AVG	P

Tested Wire: Neutral

Operation Mode: the highest power

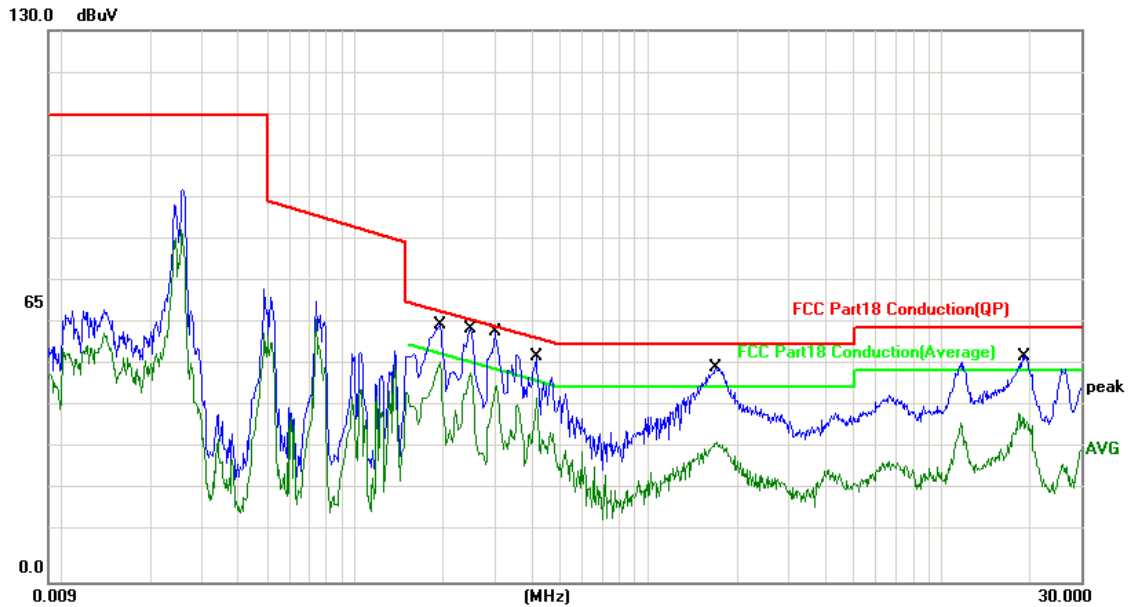

No.	Frequency (MHz)	Factor (dB)	Reading (dBuV)	Level (dBuV)	Limit (dBuV)	Margin (dB)	Detector	P/F
1	0.1949	10.00	48.60	58.60	63.82	-5.22	QP	P
2	0.1949	10.00	42.50	52.50	53.82	-1.32	AVG	P
3	0.2500	10.01	47.60	57.61	61.75	-4.14	QP	P
4	0.2500	10.01	40.20	50.21	51.75	-1.54	AVG	P
5	0.3000	10.01	45.20	55.21	60.24	-5.03	QP	P
6	0.3000	10.01	36.10	46.11	50.24	-4.13	AVG	P
7	0.4150	10.02	43.50	53.52	57.55	-4.03	QP	P
8	0.4150	10.02	34.40	44.42	47.55	-3.13	AVG	P
9	1.7100	10.05	37.40	47.45	56.00	-8.55	QP	P
10	1.7100	10.05	22.80	32.85	46.00	-13.15	AVG	P
11	19.2650	10.28	38.20	48.48	60.00	-11.52	QP	P
12	19.2650	10.28	28.40	38.68	50.00	-11.32	AVG	P

Tested Wire: Live

Operation Mode: Middle power

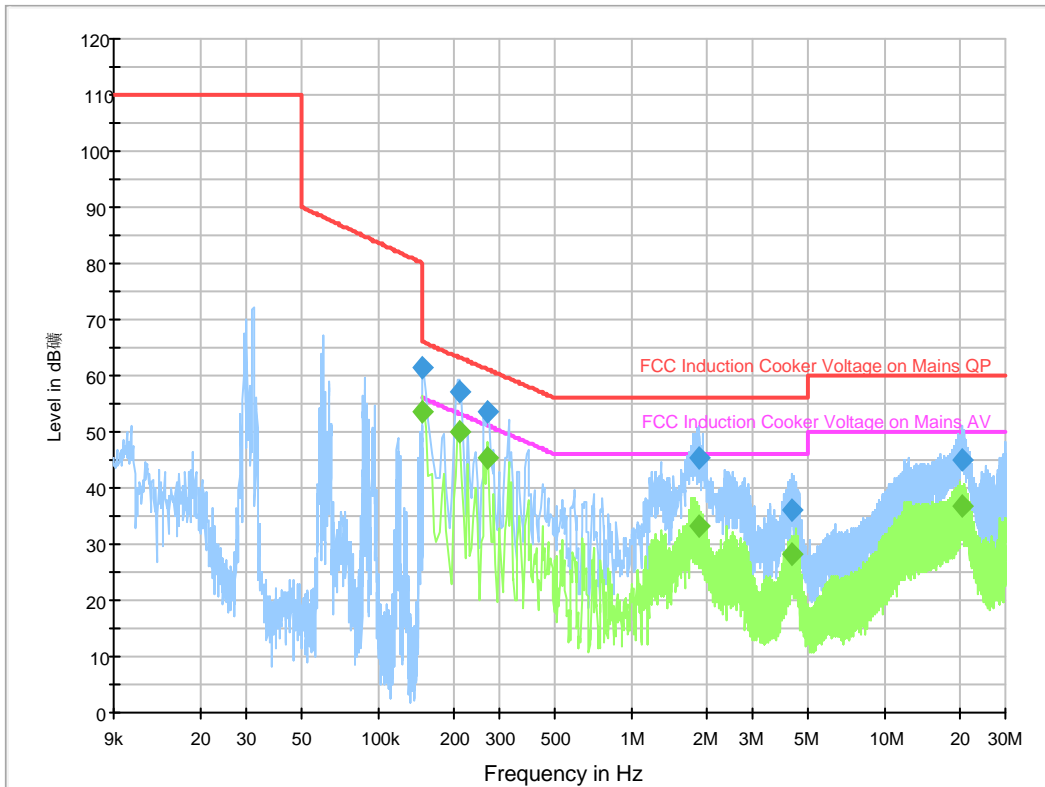

Frequency (MHz)	QuasiPeak (dBµV)	Meas. Time (ms)	Bandwidth (kHz)	PE	Line	Corr. (dB)	Margin (dB)	Limit (dBµV)
0.150	61.4	1000.	9.000	GND	L1	10.0	-4.6	66.0
0.210	57.3	1000.	9.000	GND	L1	10.0	-5.9	63.2
0.270	53.5	1000.	9.000	GND	L1	10.0	-7.7	61.1
1.834	45.2	1000.	9.000	GND	L1	10.0	-10.8	56.0
4.302	36.1	1000.	9.000	GND	L1	10.1	-19.9	56.0
20.134	45.1	1000.	9.000	GND	L1	10.4	-14.9	60.0
Frequency	Average	Meas.	Bandwidth	PE	Line	Corr.	Margin	Limit
0.150	53.7	1000.	9.000	GND	L1	10.0	-2.3	56.0
0.210	49.9	1000.	9.000	GND	L1	10.0	-3.3	53.2
0.270	45.3	1000.	9.000	GND	L1	10.0	-5.8	51.1
1.834	33.2	1000.	9.000	GND	L1	10.0	-12.8	46.0
4.302	28.2	1000.	9.000	GND	L1	10.1	-17.8	46.0
20.134	36.7	1000.	9.000	GND	L1	10.4	-13.3	50.0



Tested Wire: Neutral

Operation Mode: Middle power

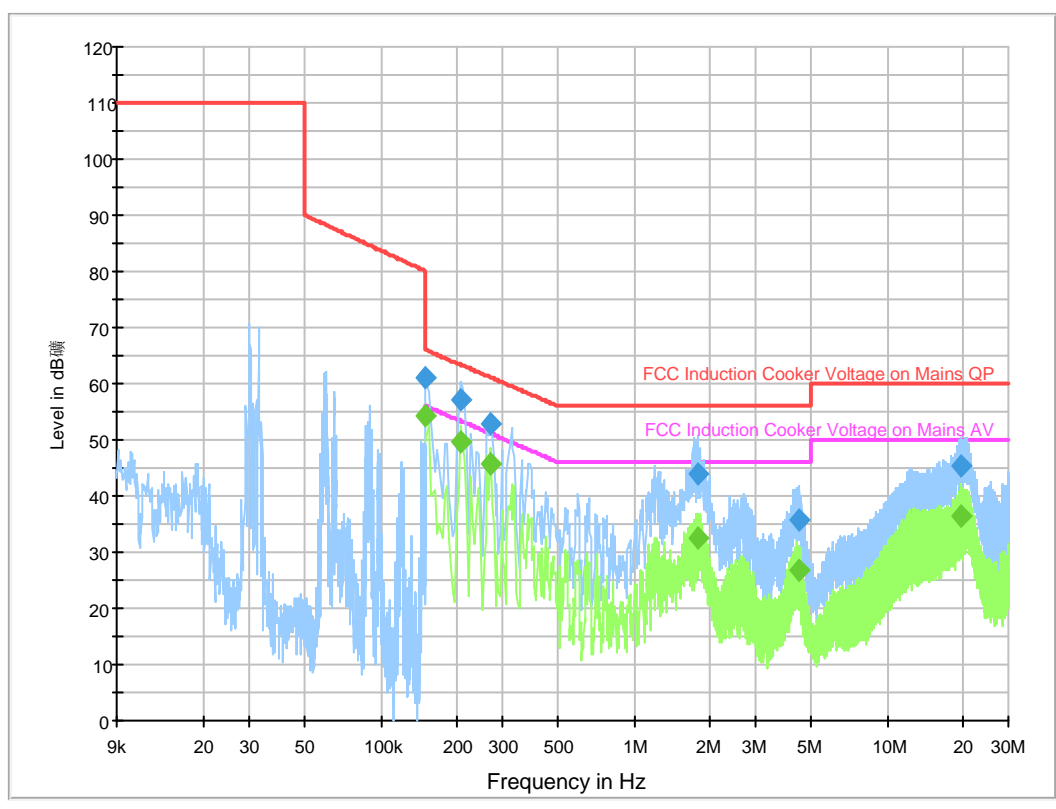

Frequency (MHz)	QuasiPeak (dBµV)	Meas. Time (ms)	Bandwidth (kHz)	PE	Line	Corr. (dB)	Margin (dB)	Limit (dBµV)
0.150	61.2	1000.	9.000	GND	N	10.0	-4.8	66.0
0.206	57.2	1000.	9.000	GND	N	10.0	-6.1	63.4
0.270	52.7	1000.	9.000	GND	N	10.0	-8.4	61.1
1.790	43.9	1000.	9.000	GND	N	10.0	-12.1	56.0
4.466	35.8	1000.	9.000	GND	N	10.1	-20.2	56.0
19.642	45.3	1000.	9.000	GND	N	10.3	-14.7	60.0
Frequency	Average	Meas.	Bandwidth	PE	Line	Corr.	Margin	Limit
0.150	54.4	1000.	9.000	GND	N	10.0	-1.6	56.0
0.206	49.5	1000.	9.000	GND	N	10.0	-3.9	53.4
0.270	45.9	1000.	9.000	GND	N	10.0	-5.3	51.1
1.790	32.6	1000.	9.000	GND	N	10.0	-13.4	46.0
4.466	26.8	1000.	9.000	GND	N	10.1	-19.2	46.0
19.642	36.6	1000.	9.000	GND	N	10.3	-13.4	50.0

Tested Wire: Live

Operation Mode: the lowest power

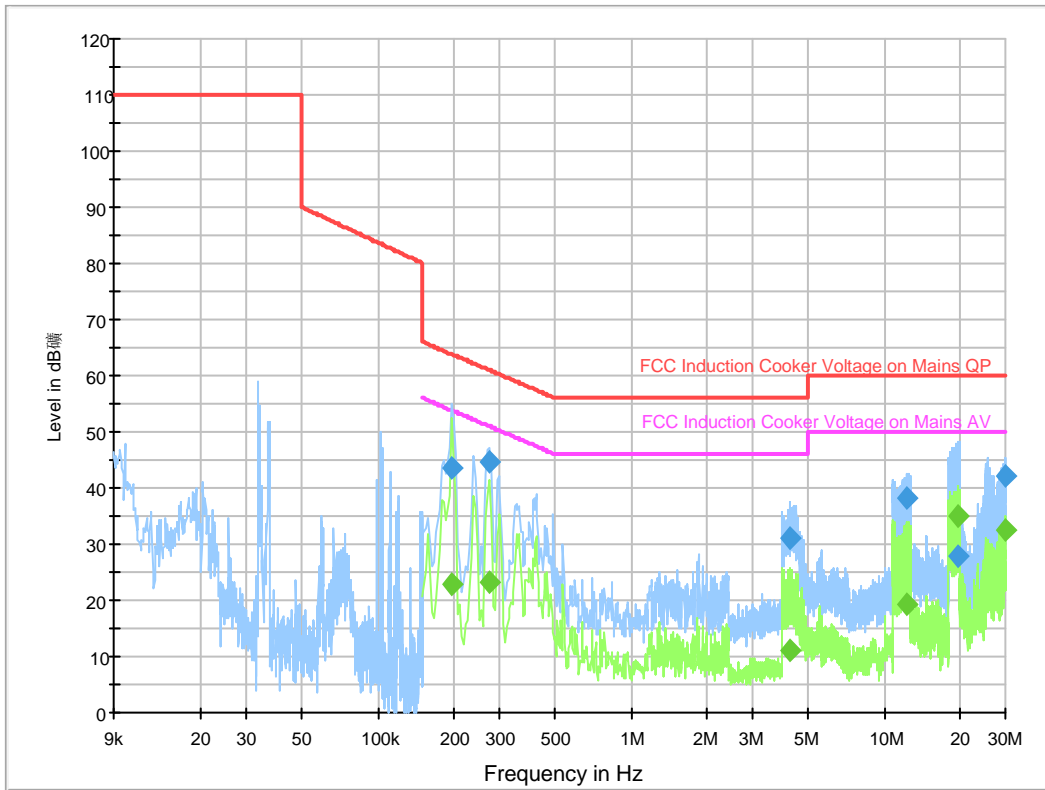

Frequency (MHz)	QuasiPeak (dBµV)	Meas. Time (ms)	Bandwidth (kHz)	PE	Line	Corr. (dB)	Margin (dB)	Limit (dBµV)
0.194	43.5	1000.	9.000	GND	L1	10.0	-20.3	63.9
0.274	44.5	1000.	9.000	GND	L1	10.0	-16.5	61.0
4.218	30.9	1000.	9.000	GND	L1	10.1	-25.1	56.0
12.154	38.4	1000.	9.000	GND	L1	10.2	-21.6	60.0
19.378	27.7	1000.	9.000	GND	L1	10.3	-32.3	60.0
29.810	42.3	1000.	9.000	GND	L1	10.4	-17.7	60.0
Frequency	Average	Meas.	Bandwidth	PE	Line	Corr.	Margin	Limit
0.194	23.0	1000.	9.000	GND	L1	10.0	-30.9	53.9
0.274	23.1	1000.	9.000	GND	L1	10.0	-27.9	51.0
4.218	11.1	1000.	9.000	GND	L1	10.1	-34.9	46.0
12.154	19.3	1000.	9.000	GND	L1	10.2	-30.7	50.0
19.378	35.0	1000.	9.000	GND	L1	10.3	-15.0	50.0
29.810	32.6	1000.	9.000	GND	L1	10.4	-17.4	50.0

Tested Wire: Neutral

Operation Mode: the lowest power

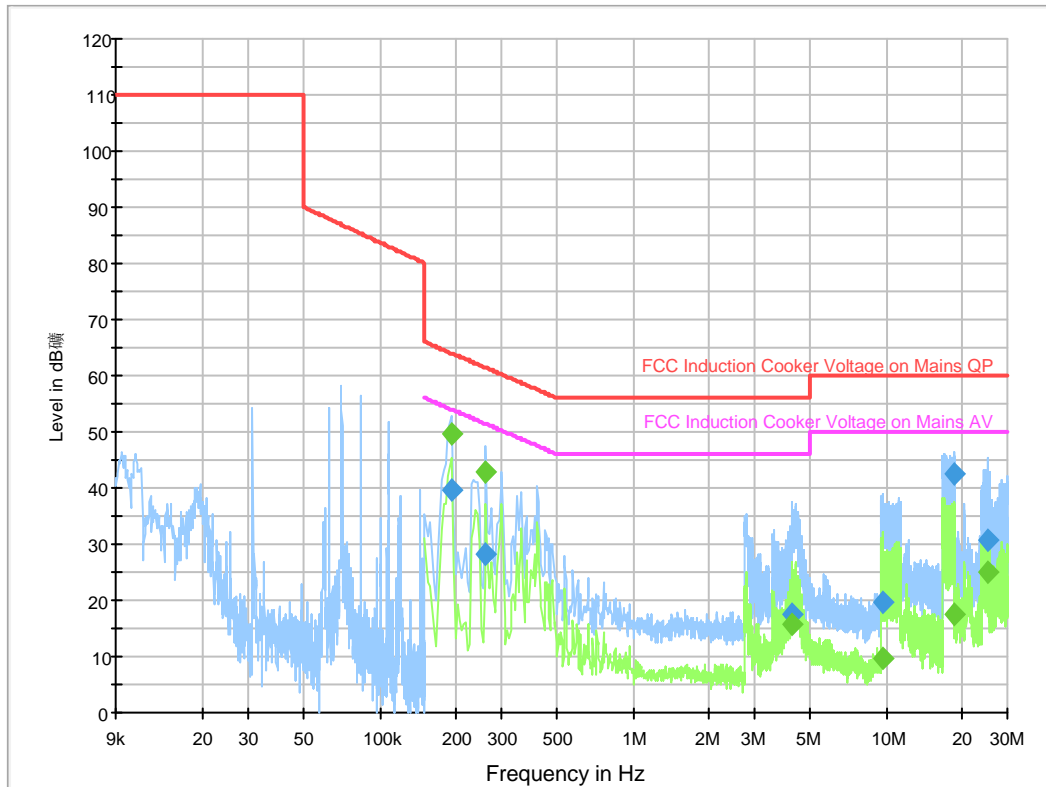

Frequency (MHz)	QuasiPeak (dBµV)	Meas. Time (ms)	Bandwidth (kHz)	PE	Line	Corr. (dB)	Margin (dB)	Limit (dBµV)
0.190	39.5	1000.	9.000	GND	N	10.0	-24.6	64.0
0.262	28.4	1000.	9.000	GND	N	10.0	-33.0	61.4
4.246	17.4	1000.	9.000	GND	N	10.1	-38.6	56.0
9.630	19.5	1000.	9.000	GND	N	10.2	-40.5	60.0
18.418	42.5	1000.	9.000	GND	N	10.3	-17.5	60.0
25.190	30.8	1000.	9.000	GND	N	10.4	-29.2	60.0
Frequency	Average	Meas.	Bandwidth	PE	Line	Corr.	Margin	Limit
0.190	49.5	1000.	9.000	GND	N	10.0	-4.6	54.0
0.262	43.0	1000.	9.000	GND	N	10.0	-8.4	51.4
4.246	15.6	1000.	9.000	GND	N	10.1	-30.4	46.0
9.630	9.6	1000.	9.000	GND	N	10.2	-40.4	50.0
18.418	17.5	1000.	9.000	GND	N	10.3	-32.5	50.0
25.190	24.9	1000.	9.000	GND	N	10.4	-25.1	50.0

5.1.5 Measurement Uncertainty

Uncertainty: 2.61 dB for frequency rang 9 kHz-150 kHz and 2.58 dB for frequency rang 150 kHz-30 MHz at a level of confidence of 95%.

5.2 Radiated Emission(9kHz - 30 MHz)

Test Result: PASS

5.2.1 Used Test Equipment

Equipment No.	Equipment	Model	Manufacturer	Last Cal.	Due Date
EE226	EMI Test Receiver	ESR3	Rohde & Schwarz	2016.5.17	2017.5.17
EE249	EMI Test Receiver	ESR3	Rohde & Schwarz	2016.5.17	2017.5.17
1029	Loop Antenna	PLA-1030/B	ARA	2016.5.29	2017.5.29

5.2.2 Block Diagram of Test Setup

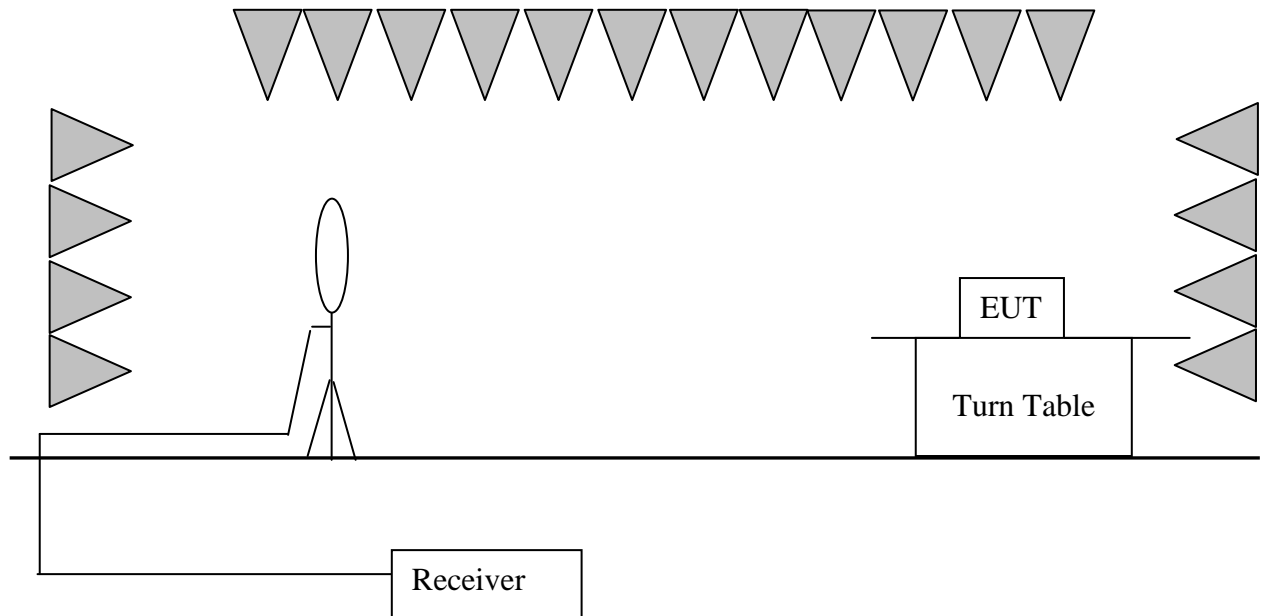

5.2.3 Test Setup and Procedure

The measurement was applied in a semi-anechoic chamber. The EUT were placed on a 1 m high wooden turntable above the horizontal metal ground plane. The turn table rotated 360 degrees to determine the position of the maximum emission level. The EUT was set 3 meters away from the receiving antenna which was mounted on an antenna tripod.

Loop antenna was used as receiving antenna. The antenna was supported in the vertical plane and was rotatable about a vertical axis to obtain the maximum emission. The antenna height of was set at 2 m above ground level.

The bandwidth setting on Receiver was 9 kHz. The frequency range from 9 kHz to 30MHz was checked.

An initial pre-scan was performed in the 10m chamber using the spectrum analyzer in peak detection mode. Average measurements were conducted based on the peak sweep graph. The EUT was measured by a 0.6m loop antenna.



5.2.4 Test Data & Curve

Tested Polarization: Vertical

Operation Mode: the highest power

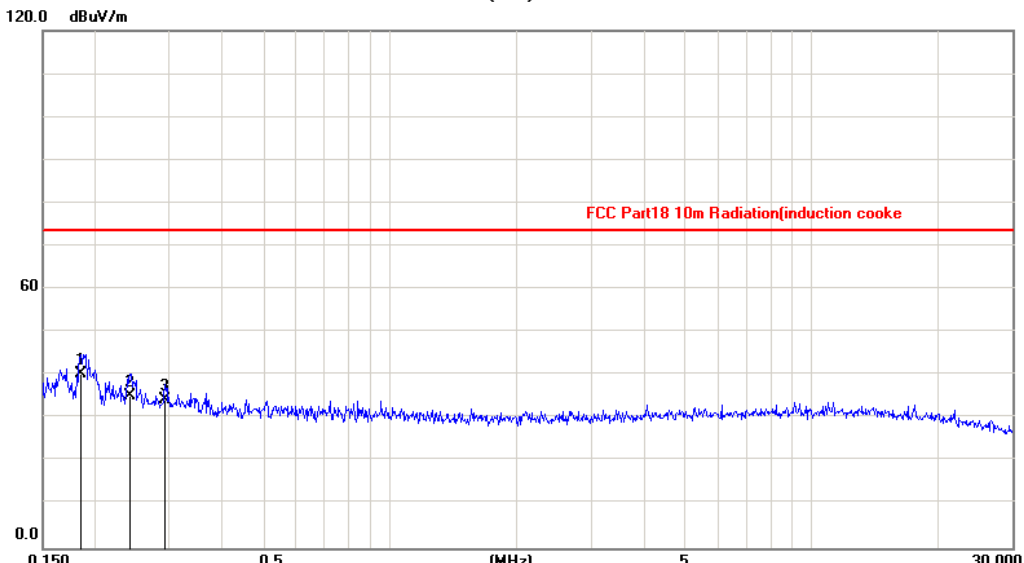
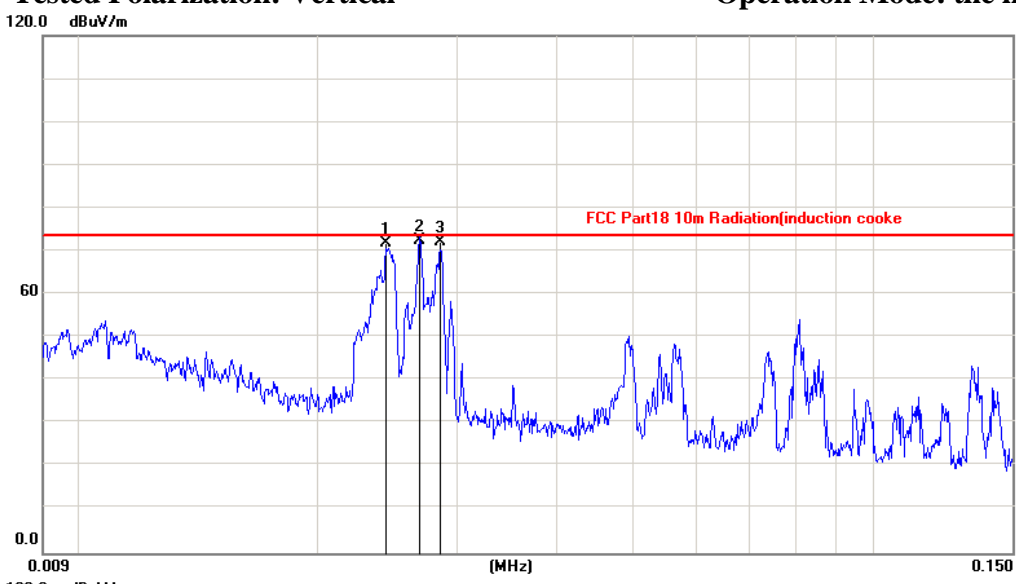

No.	Frequency (MHz)	Factor (dB/m)	Reading (dBuV)	Level (dBuV/m)	Limit (dBuV/m)	Margin (dB)	Detector	Height (cm)	Azimuth (deg.)	P/F
1	0.0244	20.32	51.48	71.80	73.50	-1.70	AVG			P
2	0.0269	20.26	52.14	72.40	73.50	-1.10	AVG			P
3	0.0285	20.22	51.88	72.10	73.50	-1.40	AVG			P

No.	Frequency (MHz)	Factor (dB/m)	Reading (dBuV)	Level (dBuV/m)	Limit (dBuV/m)	Margin (dB)	Detector	Height (cm)	Azimuth (deg.)	P/F
1	0.1844	20.35	19.95	40.30	73.50	-33.20	AVG			P
2	0.2416	20.51	14.69	35.20	73.50	-38.30	AVG			P
3	0.2924	20.65	13.55	34.20	73.50	-39.30	AVG			P



Tested Polarization: Horizontal

Operation Mode: the highest power

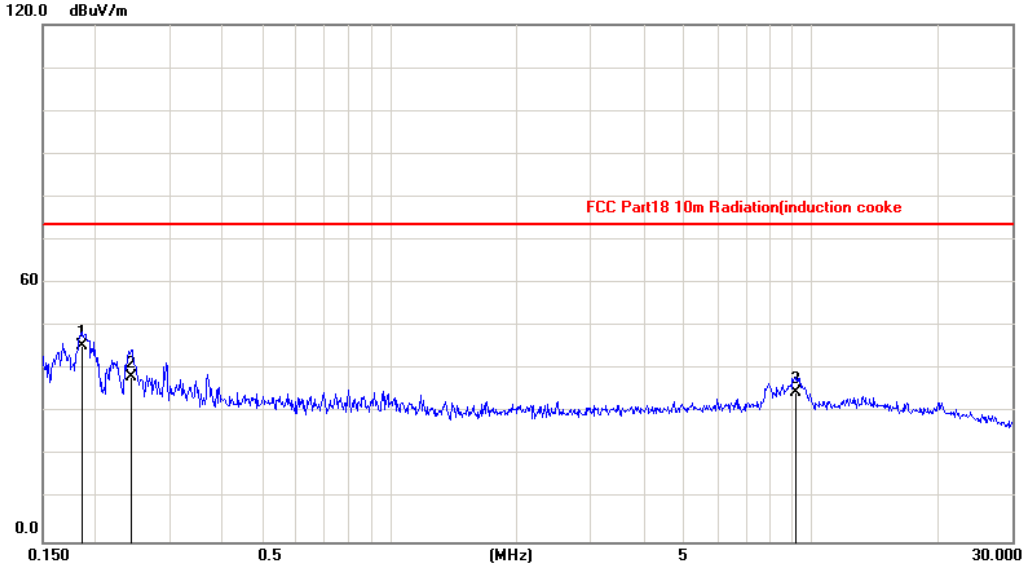
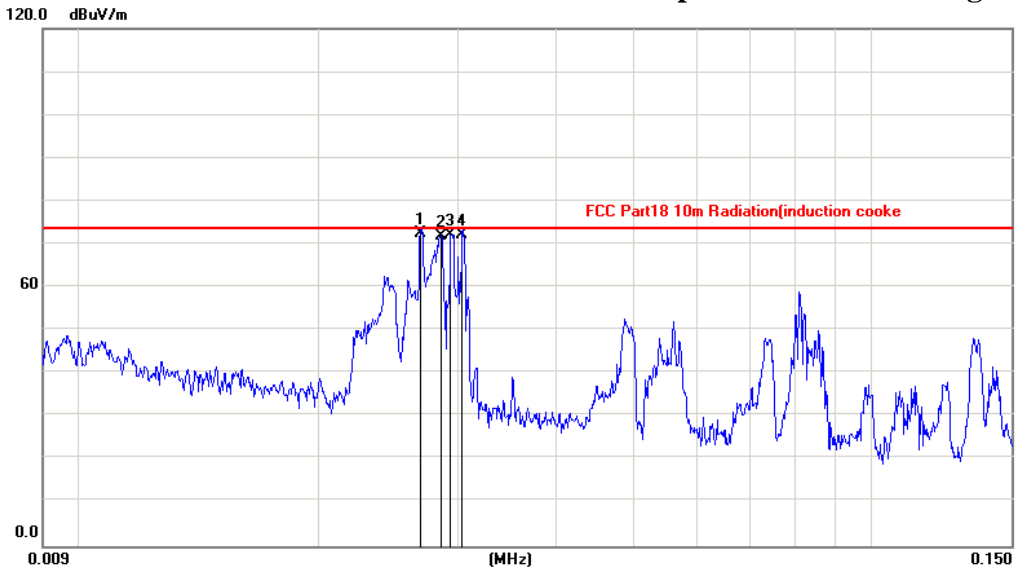

No.	Frequency (MHz)	Factor (dB/m)	Reading (dBuV)	Level (dBuV/m)	Limit (dBuV/m)	Margin (dB)	Detector	Height (cm)	Azimuth (deg.)	P/F
1	0.0269	20.26	52.14	72.40	73.50	-1.10	AVG			P
2	0.0286	20.22	51.68	71.90	73.50	-1.60	AVG			P
3	0.0293	20.20	52.00	72.20	73.50	-1.30	AVG			P
4	0.0304	20.19	52.11	72.30	73.50	-1.20	AVG			P

No.	Frequency (MHz)	Factor (dB/m)	Reading (dBuV)	Level (dBuV/m)	Limit (dBuV/m)	Margin (dB)	Detector	Height (cm)	Azimuth (deg.)	P/F
1	0.1853	20.35	25.25	45.60	73.50	-27.90	AVG			P
2	0.2429	20.52	17.78	38.30	73.50	-35.20	AVG			P
3	9.1557	20.91	13.79	34.70	73.50	-38.80	AVG			P



Tested Polarization: Vertical

Operation Mode: Middle power

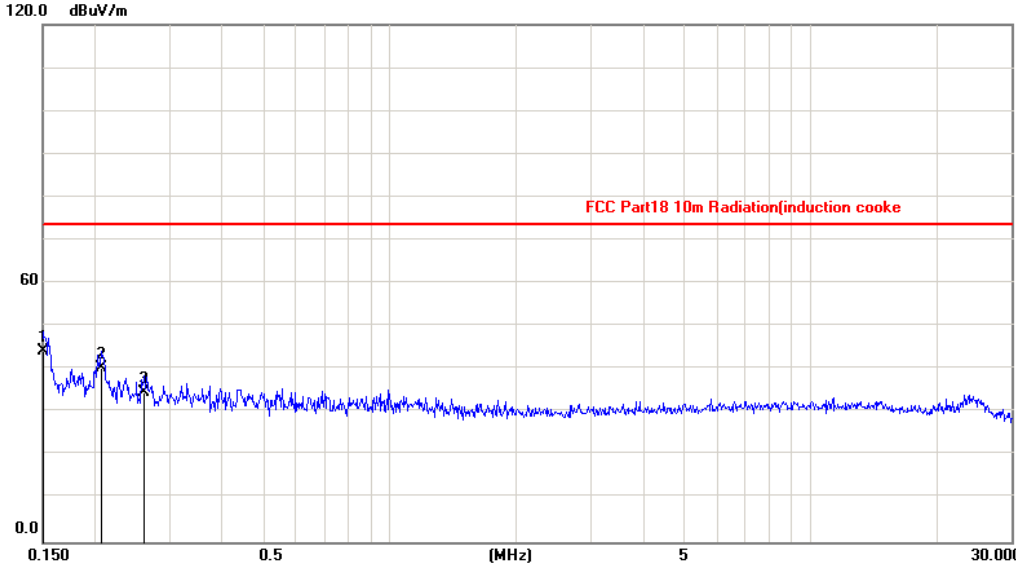
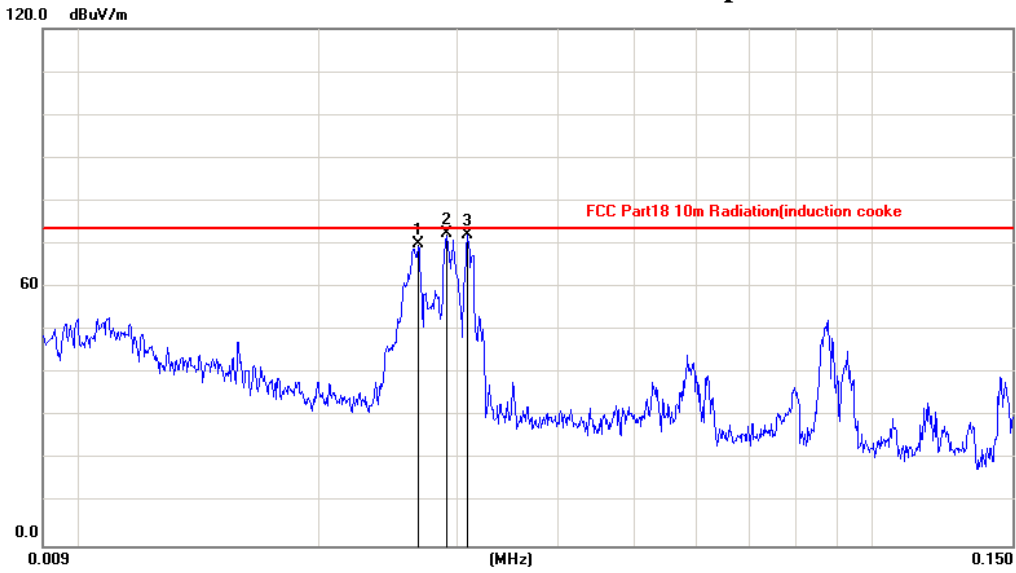

No.	Frequency (MHz)	Factor (dB/m)	Reading (dBuV)	Level (dBuV/m)	Limit (dBuV/m)	Margin (dB)	Detector	Height (cm)	Azimuth (deg.)	P/F
1	0.0267	20.26	49.64	69.90	73.50	-3.60	AVG			P
2	0.0291	20.21	52.29	72.50	73.50	-1.00	AVG			P
3	0.0309	20.20	51.90	72.10	73.50	-1.40	AVG			P

No.	Frequency (MHz)	Factor (dB/m)	Reading (dBuV)	Level (dBuV/m)	Limit (dBuV/m)	Margin (dB)	Detector	Height (cm)	Azimuth (deg.)	P/F
1	0.1500	20.26	23.94	44.20	73.50	-29.30	AVG			P
2	0.2061	20.42	19.78	40.20	73.50	-33.30	AVG			P
3	0.2615	20.57	14.03	34.60	73.50	-38.90	AVG			P



Tested Polarization: Horizontal

Operation Mode: Middle power

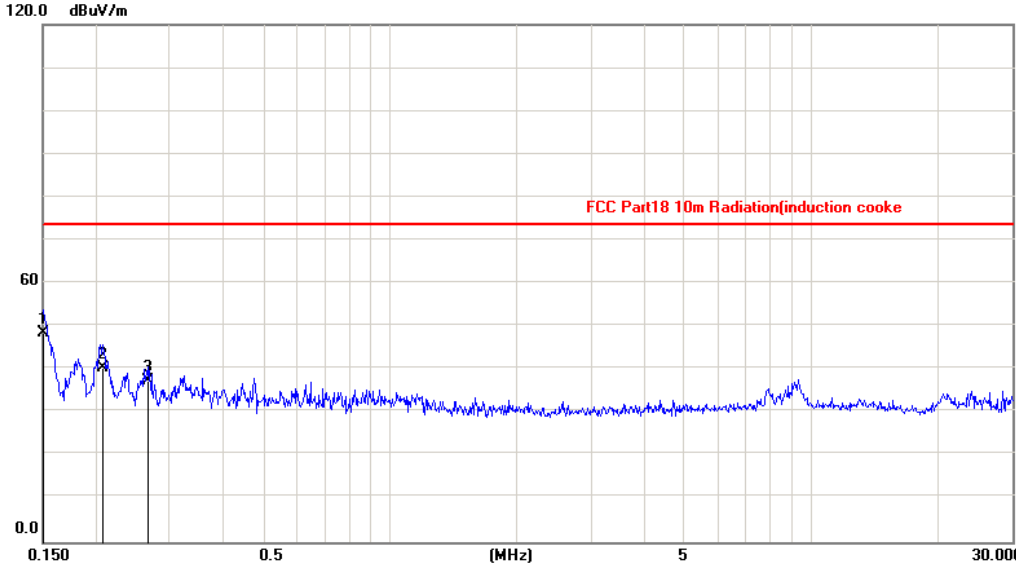
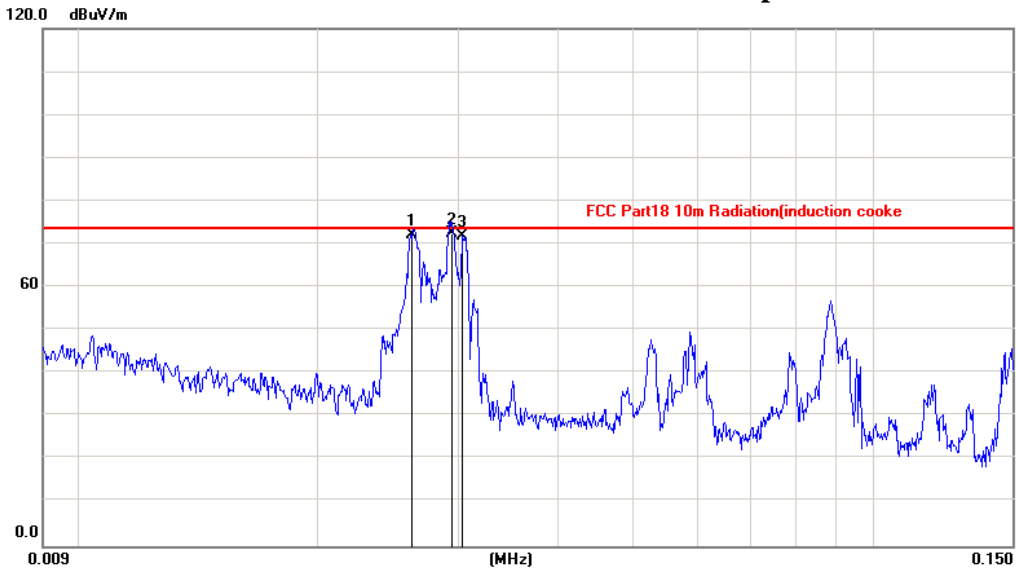

No.	Frequency (MHz)	Factor (dB/m)	Reading (dBuV)	Level (dBuV/m)	Limit (dBuV/m)	Margin (dB)	Detector	Height (cm)	Azimuth (deg.)	P/F
1	0.0262	20.28	52.02	72.30	73.50	-1.20	AVG			P
2	0.0295	20.20	52.30	72.50	73.50	-1.00	AVG			P
3	0.0304	20.19	51.51	71.70	73.50	-1.80	AVG			P

No.	Frequency (MHz)	Factor (dB/m)	Reading (dBuV)	Level (dBuV/m)	Limit (dBuV/m)	Margin (dB)	Detector	Height (cm)	Azimuth (deg.)	P/F
1	0.1500	20.26	28.34	48.60	73.50	-24.90	AVG			P
2	0.2083	20.43	19.87	40.30	73.50	-33.20	AVG			P
3	0.2672	20.58	16.62	37.20	73.50	-36.30	AVG			P



Tested Polarization: Vertical

Operation Mode: the lowest power

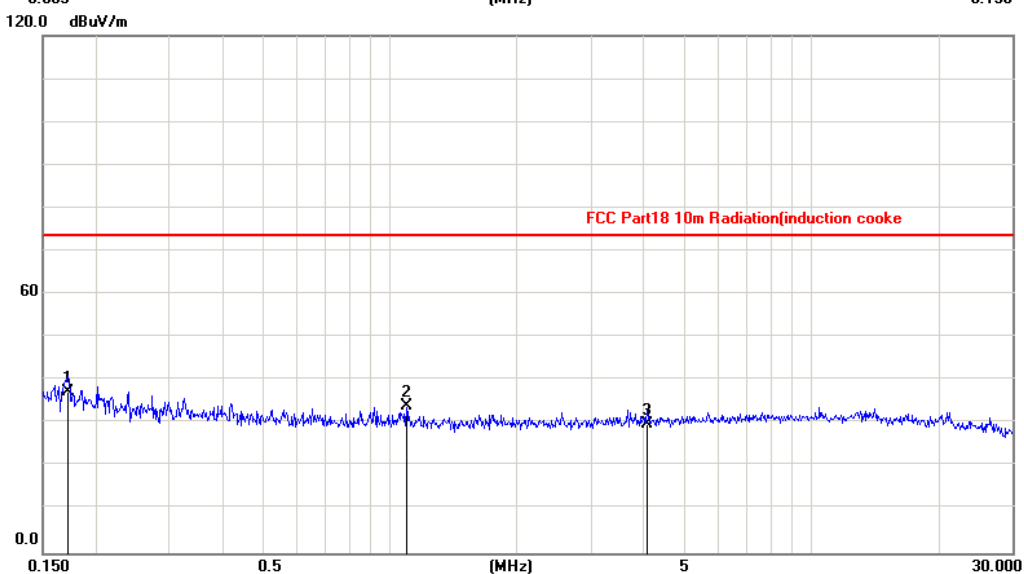
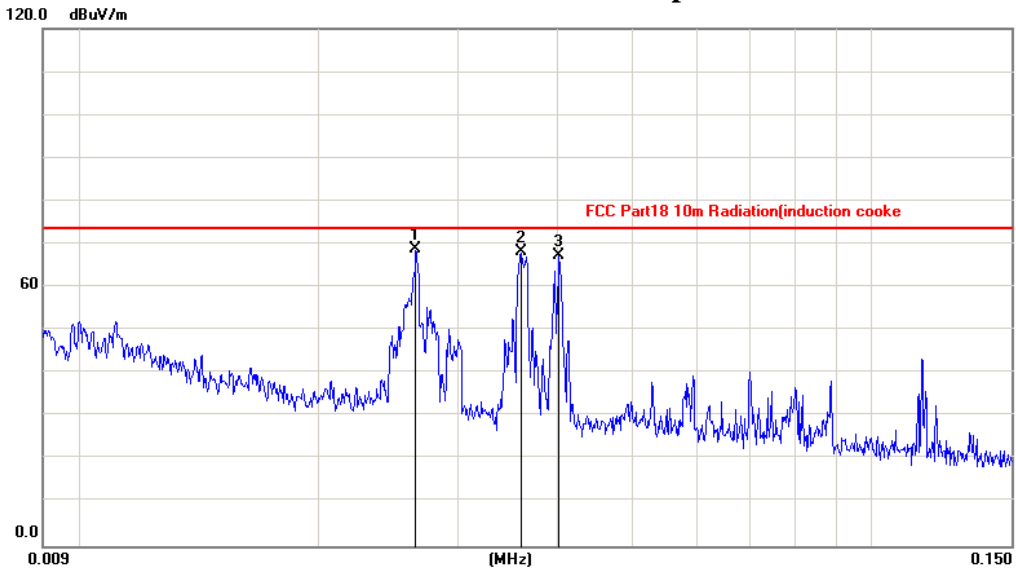

No.	Frequency (MHz)	Factor (dB/m)	Reading (dBuV)	Level (dBuV/m)	Limit (dBuV/m)	Margin (dB)	Detector	Height (cm)	Azimuth (deg.)	P/F
1	0.0266	20.27	48.63	68.90	73.50	-4.60	AVG			P
2	0.0361	20.23	47.97	68.20	73.50	-5.30	AVG			P
3	0.0403	20.25	47.15	67.40	73.50	-6.10	AVG			P

No.	Frequency (MHz)	Factor (dB/m)	Reading (dBuV)	Level (dBuV/m)	Limit (dBuV/m)	Margin (dB)	Detector	Height (cm)	Azimuth (deg.)	P/F
1	0.1722	20.32	17.08	37.40	73.50	-36.10	AVG			P
2	1.0939	20.00	14.10	34.10	73.50	-39.40	AVG			P
3	4.0704	20.29	9.51	29.80	73.50	-43.70	AVG			P



Tested Polarization: Horizontal

Operation Mode: the lowest power

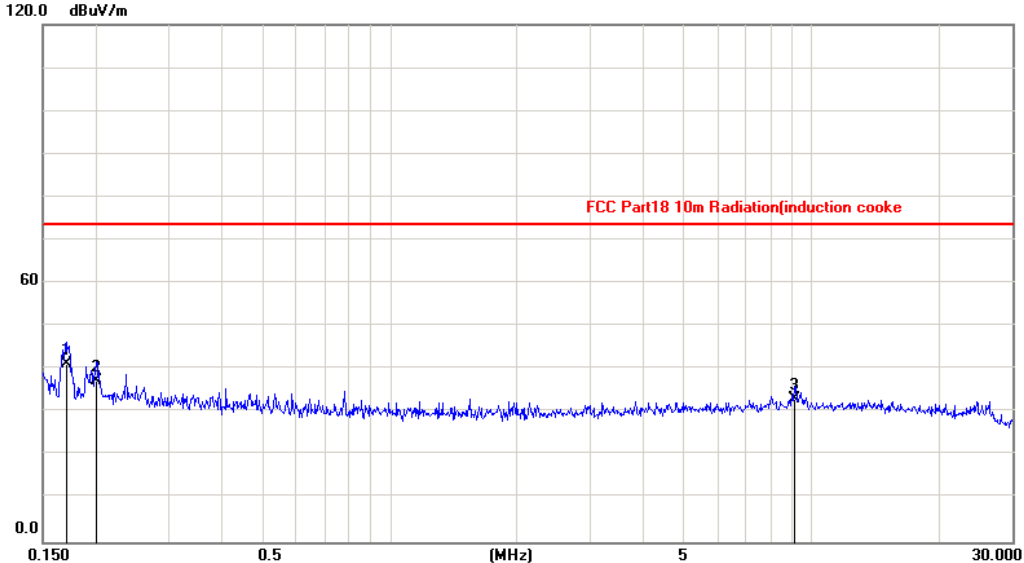
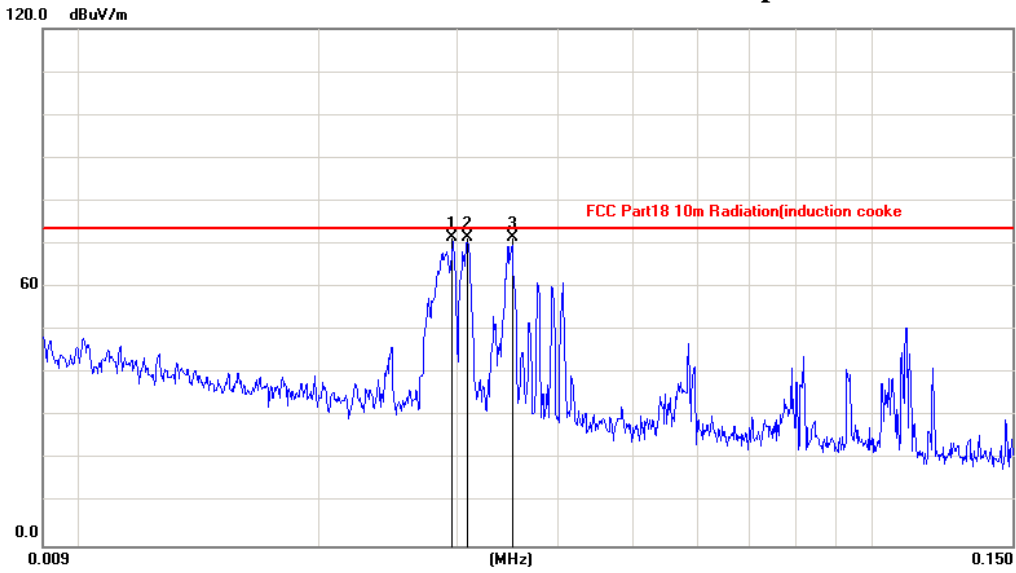

No.	Frequency (MHz)	Factor (dB/m)	Reading (dBuV)	Level (dBuV/m)	Limit (dBuV/m)	Margin (dB)	Detector	Height (cm)	Azimuth (deg.)	P/F
1	0.0295	20.20	51.30	71.50	73.50	-2.00	AVG			P
2	0.0308	20.19	51.41	71.60	73.50	-1.90	AVG			P
3	0.0351	20.23	51.17	71.40	73.50	-2.10	AVG			P

No.	Frequency (MHz)	Factor (dB/m)	Reading (dBuV)	Level (dBuV/m)	Limit (dBuV/m)	Margin (dB)	Detector	Height (cm)	Azimuth (deg.)	P/F
1	0.1703	20.31	20.99	41.30	73.50	-32.20	AVG			P
2	0.2007	20.41	16.79	37.20	73.50	-36.30	AVG			P
3	9.1073	20.91	12.19	33.10	73.50	-40.40	AVG			P



5.2.5 Measurement uncertainty

The measurement uncertainty for magnetic field radiated emission test is under consideration.

5.3 Radiated Emission (30 MHz- 1 GHz)

Test Result: Pass

5.3.1 Used Test Equipment

Equip. No.	Equipment	Model	Manufacturer	Last Cal.	Due Date
CQCSC-EMC-001	Shielded Room	TDK	8*6*4	2016/03/17	2019/03/17
CQCSC-EMC-002	EMI Test receiver	R&S	ESU8	2016/03/17	2017/03/17
CQCSC-EMC-003	Biconical Broad Band Antenna	Schwarzbeck	SWB-VULB9163	2016/03/12	2019/03/12
CQCSC-EMC-005	Horn Antenna	R&S	HF907	2016/03/12	2019/03/12
CQCSC-EMC-006	Preamplifier	R&S	SCU-18	2016/03/17	2017/03/17
CQCSC-EMC-010	Shielded Room	TDK	8*6*4	2016/03/17	2019/03/17
CQCSC-EMC-011	Chamber	TDK	9*6*6	2016/03/17	2019/03/17

5.3.2 Block Diagram of Test Setup

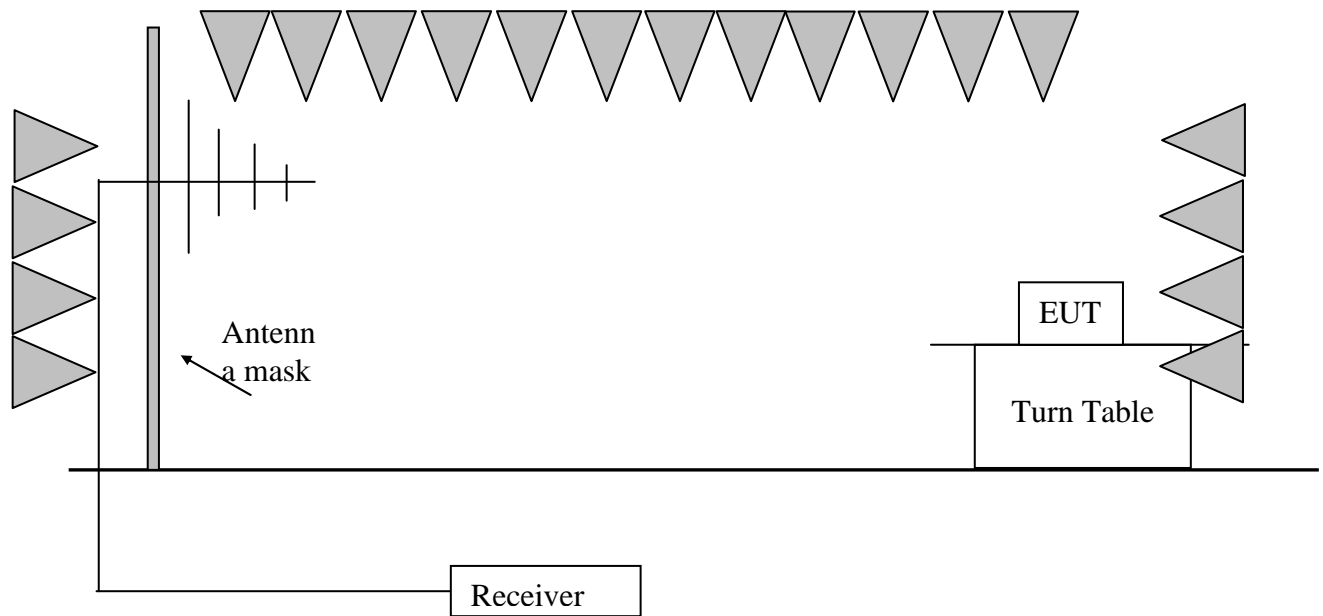

5.3.3 Test Setup and Procedure

The measurement was applied in a 3 m semi-anechoic chamber. The EUT and simulators were placed on a 1 m high wooden turntable above the horizontal metal ground plane. The turn table rotated 360 degrees to determine the position of the maximum emission level. The EUT was set 3 meters away from the receiving antenna which was mounted on an antenna mask. The antenna moved up and down between from 1 meter to 4 meters to find out the maximum emission level.

Broadband antenna was used as receiving antenna. Both horizontal and vertical polarization of the antenna was set on measurement. In order to find the maximum emission, all of the interface cables were manipulated according to FCC OST/ MP-5:1986 requirement during radiated test. The bandwidth setting on Test Receiver was 120 kHz. The frequency range from 30 MHz to 1 GHz was checked.

An initial pre-scan was performed in the 3m chamber using the spectrum analyzer in peak detection mode. Quasi-peak measurements were conducted based on the peak sweep graph.

5.3.4 Test Data & Curve

Tested Polarization: Vertical

Operation Mode: the highest power

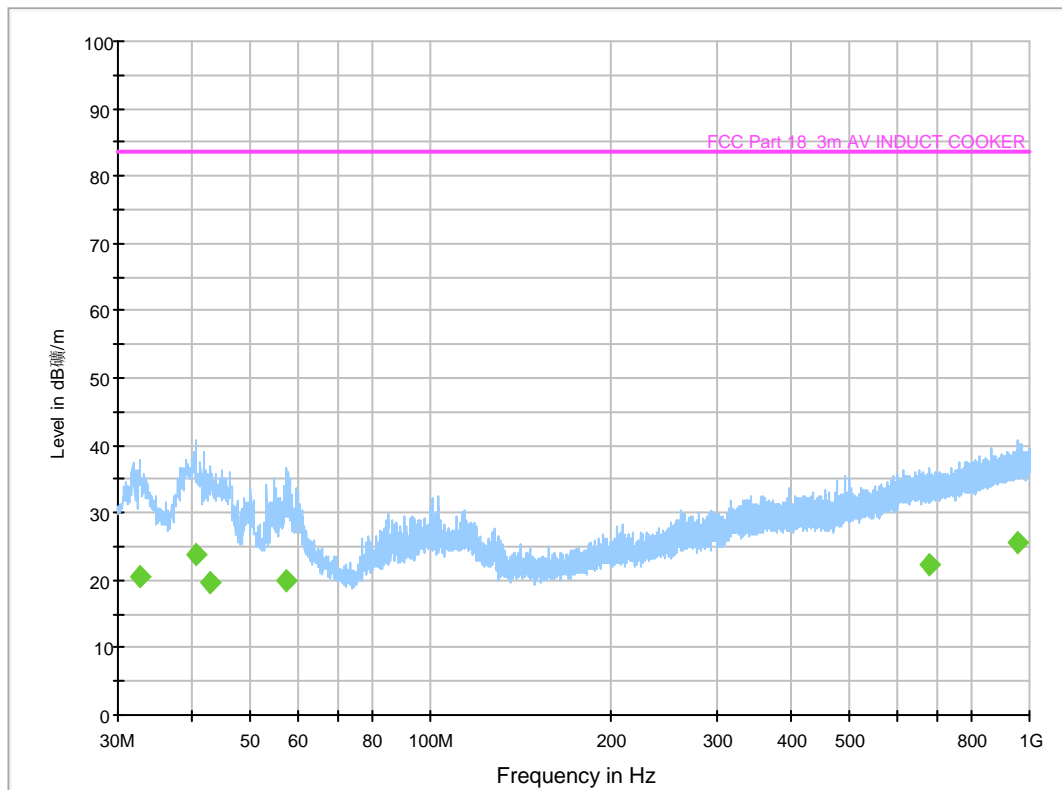

Frequency (MHz)	Average (dBµV/m)	Meas. Time (ms)	Bandwidth (kHz)	Height (cm)	Polarization	Corr. (dB)	Margin (dB)	Limit (dBµV/m)
32.619	20.6	1000.0	120.000	99.8	V	12.7	-62.9	83.5
40.525	23.8	1000.0	120.000	99.8	V	14.1	-59.7	83.5
42.853	19.7	1000.0	120.000	99.8	V	14.1	-63.8	83.5
57.451	19.9	1000.0	120.000	99.8	V	13.5	-63.6	83.5
681.937	22.2	1000.0	120.000	99.8	V	21.5	-61.3	83.5
956.593	25.7	1000.0	120.000	150.0	V	24.9	-57.8	83.5

Tested Polarization: Horizontal

Operation Mode: the highest power

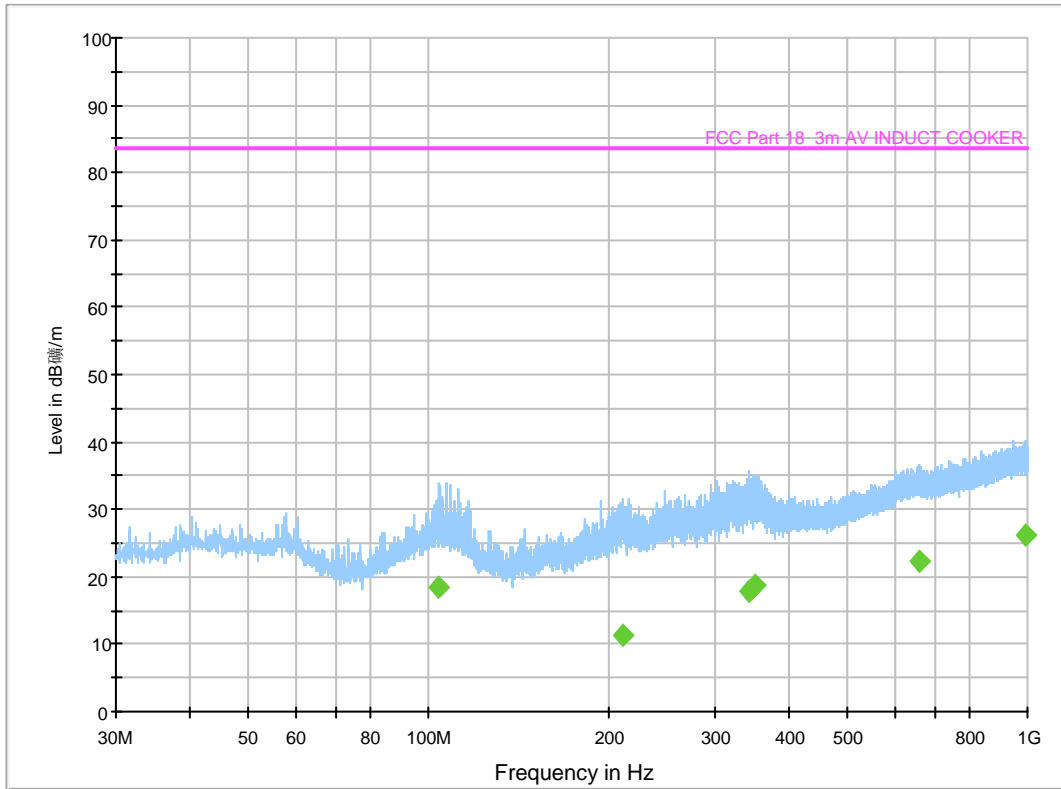

Frequency (MHz)	Average (dBµV/m)	Meas. Time (ms)	Bandwidth (kHz)	Height (cm)	Polarization	Corr. (dB)	Margin (dB)	Limit (dBµV/m)
104.108	18.5	1000.0	120.000	99.9	H	13.7	-65.0	83.5
211.536	11.4	1000.0	120.000	99.9	H	12.4	-72.1	83.5
343.407	17.9	1000.0	120.000	99.9	H	16.1	-65.6	83.5
350.779	18.8	1000.0	120.000	99.9	H	16.2	-64.7	83.5
659.870	22.4	1000.0	120.000	150.1	H	21.4	-61.1	83.5
994.568	26.1	1000.0	120.000	150.1	H	25.1	-57.4	83.5

Tested Polarization: Vertical

Operation Mode: Middle power

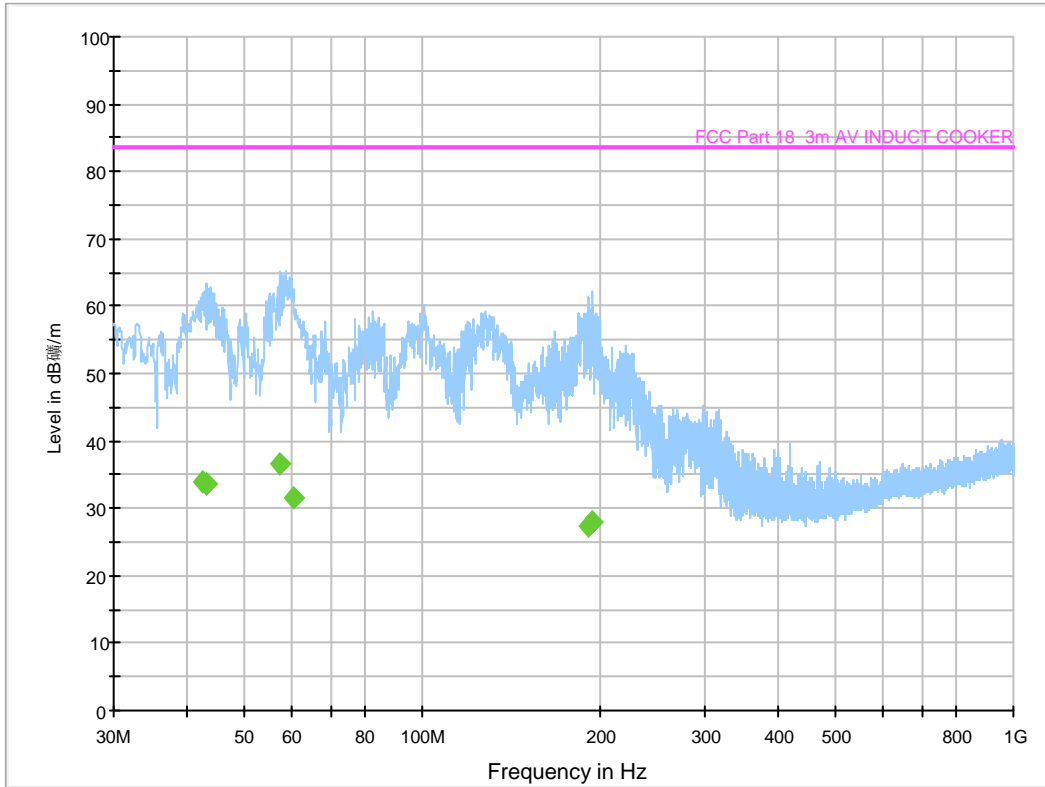

Frequency (MHz)	Average (dBµV/m)	Meas. Time (ms)	Bandwidth (kHz)	Height (cm)	Polarization	Corr. (dB)	Margin (dB)	Limit (dBµV/m)
42.367	34.1	1000.	120.000	99.9	V	14.1	-49.4	83.5
43.143	33.5	1000.	120.000	99.9	V	14.1	-50.0	83.5
57.499	36.6	1000.	120.000	99.9	V	13.5	-46.9	83.5
60.603	31.4	1000.	120.000	150.1	V	13.1	-52.1	83.5
190.438	27.4	1000.	120.000	150.1	V	11.9	-56.1	83.5
193.930	28.1	1000.	120.000	150.1	V	11.9	-55.4	83.5

Tested Polarization: Horizontal

Operation Mode: Middle power

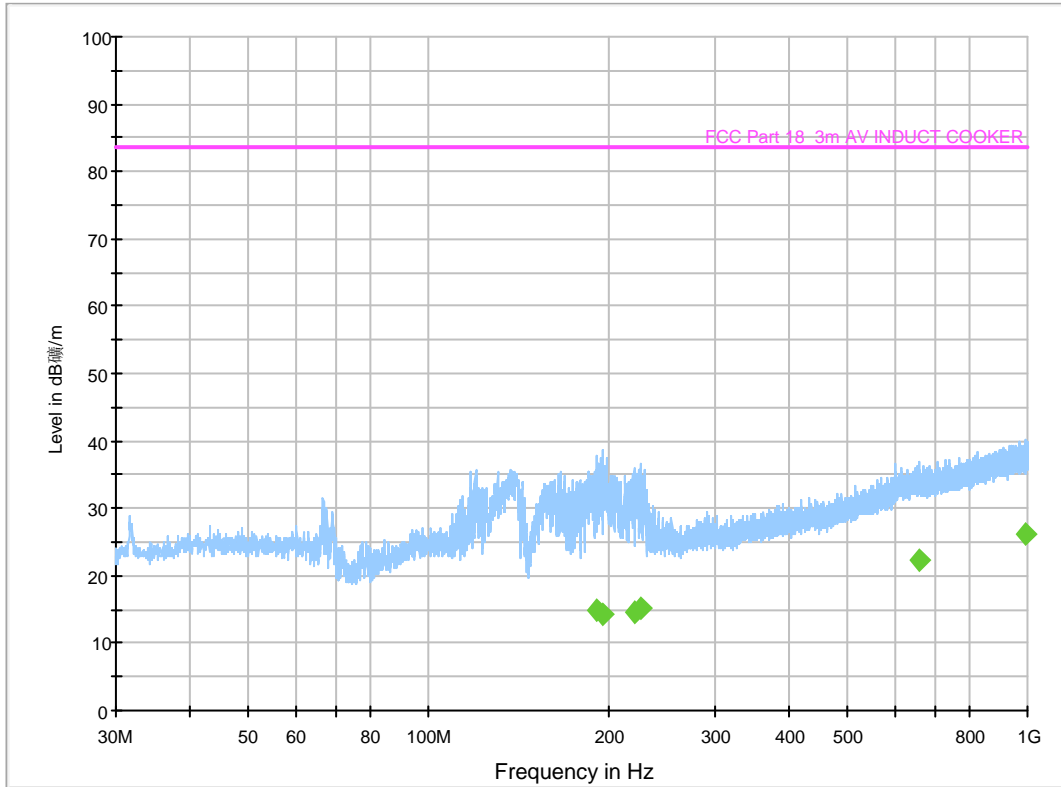

Frequency (MHz)	Average (dBµV/m)	Meas. Time (ms)	Bandwidth (kHz)	Height (cm)	Polarization	Corr. (dB)	Margin (dB)	Limit (dBµV/m)
191.214	14.8	1000.0	120.000	150.0	H	11.9	-68.7	83.5
195.482	14.4	1000.0	120.000	99.9	H	11.9	-69.1	83.5
221.624	14.5	1000.0	120.000	99.9	H	12.7	-69.0	83.5
226.328	15.2	1000.0	120.000	99.9	H	13.0	-68.3	83.5
661.955	22.4	1000.0	120.000	99.9	H	21.4	-61.1	83.5
991.852	26.1	1000.0	120.000	150.0	H	25.1	-57.4	83.5

Tested Polarization: Vertical

Operation Mode: the lowest power

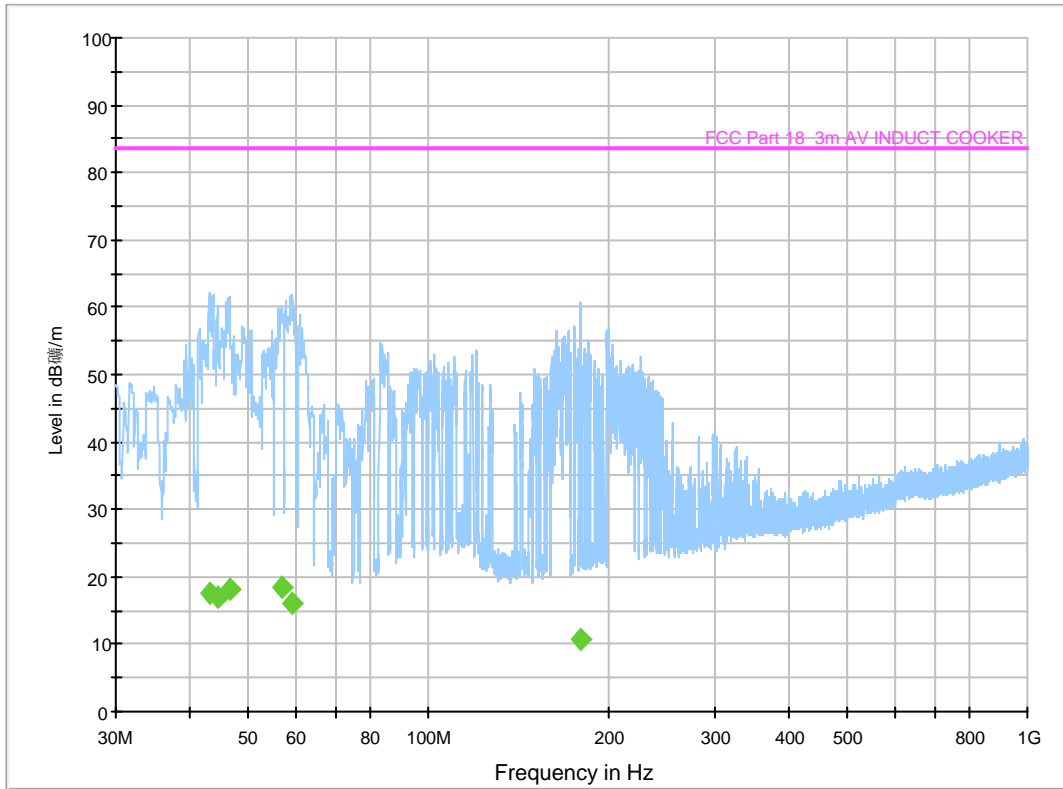

Frequency (MHz)	Average (dBµV/m)	Meas. Time (ms)	Bandwidth (kHz)	Height (cm)	Polarization	Corr. (dB)	Margin (dB)	Limit (dBµV/m)
43.144	17.5	1000.0	120.000	150.0	V	14.1	-66.0	83.5
44.356	17.1	1000.0	120.000	99.9	V	14.1	-66.4	83.5
46.393	18.2	1000.0	120.000	99.9	V	14.0	-65.3	83.5
56.966	18.3	1000.0	120.000	150.0	V	13.5	-65.2	83.5
58.906	16.2	1000.0	120.000	99.9	V	13.4	-67.3	83.5
179.526	10.8	1000.0	120.000	150.0	V	10.9	-72.7	83.5

Tested Polarization: Horizontal

Operation Mode: the lowest power

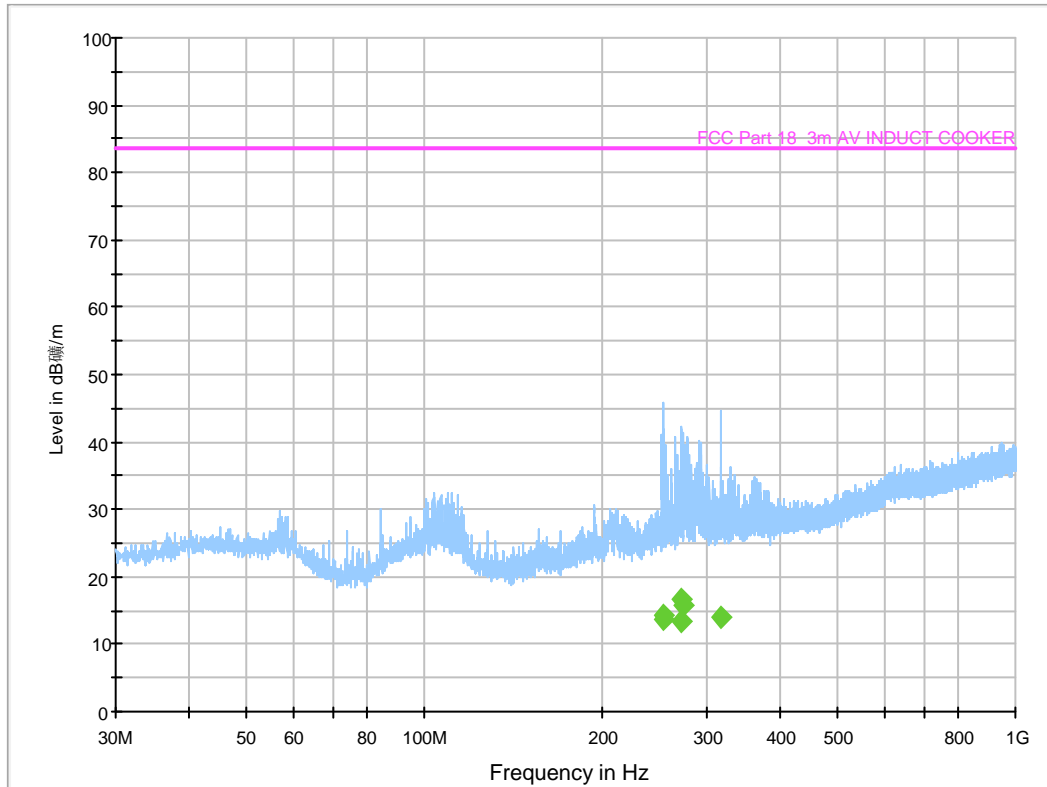

Frequency (MHz)	Average (dBµV/m)	Meas. Time (ms)	Bandwidth (kHz)	Height (cm)	Polarization	Corr. (dB)	Margin (dB)	Limit (dBµV/m)
252.857	14.3	1000.	120.000	99.8	H	13.6	-69.2	83.5
254.118	13.6	1000.	120.000	99.8	H	13.6	-69.9	83.5
271.530	13.4	1000.	120.000	99.8	H	14.1	-70.1	83.5
271.724	16.8	1000.	120.000	99.8	H	14.1	-66.7	83.5
274.682	15.8	1000.	120.000	99.8	H	14.2	-67.7	83.5
316.247	14.1	1000.	120.000	99.8	H	15.1	-69.4	83.5

5.3.5 Measurement uncertainty

Uncertainty: 4.54 dB in the frequency range of 30-1000 MHz at a level of confidence of 95%