



Hermon Laboratories Ltd.
Harakevet Industrial Zone, Binyamina 30500,
Israel
Tel. +972-4-6288001
Fax. +972-4-6288277
E-mail: mail@hermonlabs.com

TEST REPORT

ACCORDING TO: FCC CFR 47 Part 15 subpart C, section 15.231 (a) and subpart B
RSS-210 issue 8 Annex 1, ICES-003 Issue 5:2012

FOR:

Essence Security International Ltd.
Control Panel
Model: ES6502HC
FCC ID:YXG-ES6502HC
IC:11061A-ES6502HC

This report is in conformity with ISO/IEC 17025. The "A2LA Accredited" symbol endorsement applies only to the tests and calibrations that are listed in the scope of Hermon Laboratories accreditation. The test results relate only to the items tested. This test report shall not be reproduced in any form except in full with the written approval of Hermon Laboratories Ltd.

Table of contents

1	Applicant information.....	3
2	Equipment under test attributes	3
3	Manufacturer information	3
4	Test details.....	3
5	Tests summary.....	4
6	EUT description.....	5
6.1	General information.....	5
6.2	Test configuration.....	5
6.3	Changes made in EUT.....	5
6.4	Transmitter characteristics	6
7	Transmitter tests according to 47CFR part 15 subpart C and RSS-210 Annex 1 requirements.....	7
7.1	Periodic operation requirements	7
7.2	Field strength of emissions.....	11
7.3	Occupied bandwidth test.....	24
7.4	Conducted emissions.....	26
7.5	Antenna requirements.....	30
8	Unintentional emissions	31
8.1	Conducted emissions.....	31
8.2	Radiated emission measurements	35
9	APPENDIX A Test equipment and ancillaries used for tests.....	41
10	APPENDIX B Measurement uncertainties.....	42
11	APPENDIX C Test laboratory description	43
12	APPENDIX D Specification references	43
13	APPENDIX E Test equipment correction factors.....	44
14	APPENDIX F Abbreviations and acronyms.....	51

1 Applicant information

Client name: Essence Security International Ltd.
Address: 12 Abba Eban avenue, Ackerstein Tower Bldg. D, P.O.Box 2073, Herzliya 4612001, Israel
Telephone: +972 7324 47735
Fax: +972 9772 9962
E-mail: ilyafe@essence-grp.com
Contact name: Mr. Ilya Feldman

2 Equipment under test attributes

Product name: Control Panel
Product type: Transceiver
Model(s): ES6502HC
Serial number: 11130093900100003
Hardware version: V1
Software release: 8.11.252.1.8.8
Receipt date 6/6/2013

3 Manufacturer information

Manufacturer name: Essence Security International Ltd.
Address: 12 Abba Eban avenue, Ackerstein Tower Bldg. D, P.O.Box 2073, Herzliya 4612001, Israel
Telephone: +972 7324 47735
Fax: +972 9772 9962
E-Mail: ilyafe@essence-grp.com
Contact name: Mr. Ilya Feldman

4 Test details





Project ID: 24388
Location: Hermon Laboratories Ltd. Harakevet Industrial Zone, Binyamina 30500, Israel
Test started: 6/9/2013
Test completed: 6/10/2013
Test specification(s): FCC 47CFR part 15, subpart C, §15.231(a), subpart B;
RSS-210 issue 8 Annex 1, RSS-Gen issue 3, ICES-003 issue 5:2012



5 Tests summary

Test	Status
Transmitter characteristics	
FCC Part 15, Section 231(a) / RSS-210, Section A1.1.1, Periodic operation requirements	Pass
FCC Part 15, Section 231(b) / RSS-210, Section A1.1.2, Field strength of emissions	Pass
FCC Part 15, Section 231(c) / RSS-210, Section A1.1.3, Occupied bandwidth	Pass
FCC Part 15, Section 207 / RSS-Gen, Section 7.2.4, Conducted emission	Pass
FCC Part 15, Section 203 / RSS-Gen, Section 7.1.2, Antenna requirements	Pass
Unintentional emissions	
FCC Part 15, Section 107 / RSS-Gen, Section 7.2.4, Conducted emission at AC power port	Pass
FCC Part 15, Section 109 / RSS-Gen, Section 6.1, ICES-003, Section 6.2 class B, Radiated emission	Pass

Testing was completed against all relevant requirements of the test standard. The results obtained indicate that the product under test complies in full with the requirements tested.
The test results relate only to the items tested. Pass/ fail decision was based on nominal values.

	Name and Title	Date	Signature
Tested by:	Mrs. E. Pitt, test engineer Mr. Alex Chaplik, test engineer	June 10, 2013	 
Reviewed by:	Mrs. M. Cherniavsky, certification engineer	July 10, 2013	
Approved by:	Mr. M. Nikishin, EMC and Radio group manager	July 12, 2013	



6 EUT description

6.1 General information

The EUT is a Control Panel operating at 916.5 MHz and designed for the growing population, disabled and people that suffer from dementia and that wishes to “age peacefully at home”. The EUT includes the WWAN module manufactured by Telit Communications S.p.A., approved by FCC and Industry Canada, FCC ID:RI7HE910NA, IC:5131A-HE910NA.

6.2 Test configuration

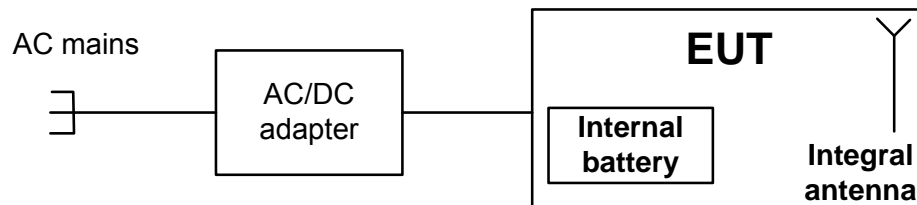

6.3 Changes made in EUT

No changes were implemented in the EUT during the testing.



6.4 Transmitter characteristics

Type of equipment						
X	Stand-alone (Equipment with or without its own control provisions)					
	Combined equipment (Equipment where the radio part is fully integrated within another type of equipment)					
	Plug-in card (Equipment intended for a variety of host systems)					
Operating frequency		916.5 MHz				
Maximum rated output power		At transmitter 50 Ω RF output connector			dBm	
		Field strength at 3 m distance			101.0 dB(μV/m) – peak 79.07 dB(μV/m) -average	
Is transmitter output power variable?		X	No			
		Yes		continuous variable		
				stepped variable with stepsize		dB
			minimum RF power			dBm
			maximum RF power			dBm
Antenna connection						
	unique coupling		standard connector	X	integral	
					X	
					with temporary RF connector	
					without temporary RF connector	
Type of modulation		2FSK				
Transmitter power source						
	Battery	Nominal rated voltage	VDC			
	DC	Nominal rated voltage	VDC			
X	AC mains	Nominal rated voltage	120 VAC via AC/DC adapter	Frequency 60 Hz		
Common power source for transmitter and receiver				X	yes	no



Test specification:	FCC Part 15, Section 231(a) / RSS-210, Section A1.1.1, Periodic operation requirements		
Test procedure:	Supplier declaration		
Test mode:	Compliance	Verdict:	PASS
Date(s):	6/9/2013		
Temperature: 25 °C	Air Pressure: 1005 hPa	Relative Humidity: 34 %	Power Supply: 120 VAC
Remarks:			

7 Transmitter tests according to 47CFR part 15 subpart C and RSS-210 Annex 1 requirements

7.1 Periodic operation requirements

7.1.1 General

The EUT was verified for compliance with periodic operation requirements listed below:

- Continuous transmissions such as voice, video and the radio control of toys are not permitted;
- A manually operated transmitter shall employ switch that will automatically deactivate the transmitter within not more than 5 seconds of being released;
- A transmitter activated automatically shall cease transmission within 5 seconds after activation;
- Periodic transmissions, excluding polling or supervision transmissions, at regular predetermined intervals are not permitted;
- Total duration of polling or supervision transmissions, including data, to determine system integrity in security or safety applications shall not exceed 2 seconds per hour;
- Transmission of set-up information for security systems may exceed the transmission duration limits of 5 seconds, provided such transmissions are under the control of a professional installer and do not exceed ten seconds after a manually operated switch is released or a transmitter is activated automatically. Such set-up information may include data.

The rationale for compliance with the above requirements was either test results or supplier declaration. The summary of results is provided in Table 7.1.1.

7.1.2 Test procedure for transmitter shut down test

7.1.2.1 The EUT was set up as shown in Figure 7.1.1.

7.1.2.2 The spectrum analyzer center frequency was adjusted to the EUT carrier, span set to zero and video triggered for transmission.

7.1.2.3 The transmitter was activated either manually or automatically. Once manually operated transmitter was activated, the switch was immediately released.

7.1.2.4 The transmission time was captured and shown in Plot 7.1.1, Plot 7.1.2.

7.1.3 Test procedure for measurements of polling / supervision transmission duration

7.1.3.1 The EUT was set up as shown in Figure 7.1.1.

7.1.3.2 The spectrum analyzer center frequency was adjusted to the EUT carrier, span set to zero and video triggered for transmission.

7.1.3.3 The transmission time was captured and shown in Table 7.1.2.

Figure 7.1.1 Setup for transmitter shut down test





Test specification:	FCC Part 15, Section 231(a) / RSS-210, Section A1.1.1, Periodic operation requirements		
Test procedure:	Supplier declaration		
Test mode:	Compliance	Verdict:	PASS
Date(s):	6/9/2013		
Temperature: 25 °C	Air Pressure: 1005 hPa	Relative Humidity: 34 %	Power Supply: 120 VAC
Remarks:			

Table 7.1.1 Periodic operation requirements

Requirement	Rationale	Verdict
Continuous transmissions are not permitted	Supplier declaration	Comply
A manually operated transmitter shall be deactivated within not more than 5 seconds of switch being released	NA	NA
Transmitter activated automatically shall cease transmission within 5 seconds	Plot 7.1.1, Plot 7.1.2	Pass
Periodic transmissions at regular predetermined intervals are not permitted	Supplier declaration	Comply
Total duration of polling or supervision transmissions shall not exceed 2 seconds per hour	NA	NA
Transmission of set-up information for security systems may exceed the transmission duration limits of 5 seconds, provided such transmissions are under the control of a professional installer and do not exceed ten seconds after a manually operated switch is released or a transmitter is activated automatically. Such set-up information may include data.	NA	NA



Test specification:	FCC Part 15, Section 231(a) / RSS-210, Section A1.1.1, Periodic operation requirements		
Test procedure:	Supplier declaration		
Test mode:	Compliance	Verdict:	PASS
Date(s):	6/9/2013		
Temperature: 25 °C	Air Pressure: 1005 hPa	Relative Humidity: 34 %	Power Supply: 120 VAC
Remarks:			

Plot 7.1.1 Transmitter shut down test result

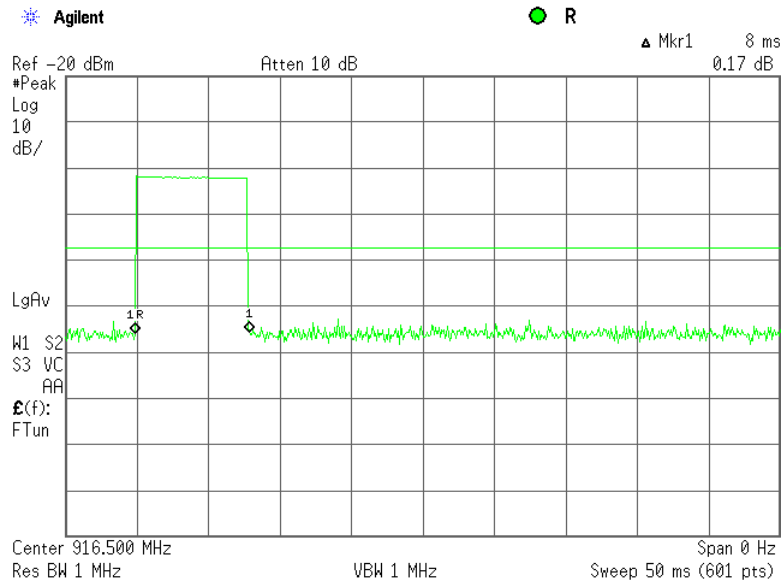

Plot 7.1.2 Transmitter shut down test result

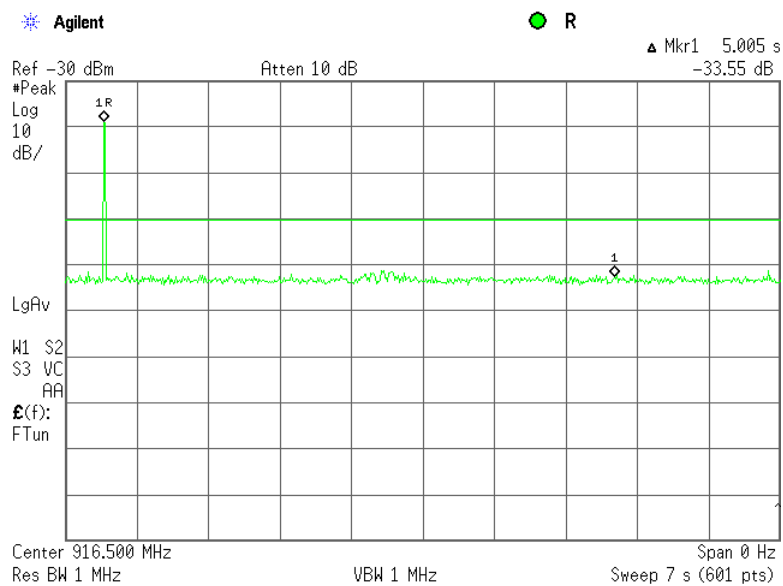



Test specification:	FCC Part 15, Section 231(a) / RSS-210, Section A1.1.1, Periodic operation requirements		
Test procedure:	Supplier declaration		
Test mode:	Compliance	Verdict:	PASS
Date(s):	6/9/2013		
Temperature: 25 °C	Air Pressure: 1005 hPa	Relative Humidity: 34 %	Power Supply: 120 VAC
Remarks:			

Table 7.1.2 Total duration of polling / supervision transmissions

Duration, ms	Repetition period, ms	Maximum number of transmissions within 1 hour	Total duration within 1 hour, ms
NA	NA	NA	NA

Reference numbers of test equipment used

HL 3818						
---------	--	--	--	--	--	--

Full description is given in Appendix A.



Test specification:	FCC Part 15, Section 231(b) / RSS-210, Section A1.1.2, Field strength of emissions		
Test procedure:	ANSI C63.4, Section 13.1.4		
Test mode:	Compliance	Verdict:	PASS
Date(s):	6/9/2013 - 6/10/2013		
Temperature: 25.6 °C	Air Pressure: 1005 hPa	Relative Humidity: 41 %	Power Supply: 120 VAC
Remarks:			

7.2 Field strength of emissions

7.2.1 General

This test was performed to measure field strength of fundamental and spurious emissions from the EUT. Specification test limits are given in Table 7.2.1 and Table 7.2.2.

Table 7.2.1 Radiated fundamental emission limits

Fundamental frequency, MHz	Field strength at 3 m, dB(μV/m)	
	Peak	Average
916.5	102	82

Table 7.2.2 Radiated spurious emissions limits

Frequency, MHz	Field strength at 3 m, dB(μV/m)				
	Within restricted bands			Outside restricted bands	
	Peak	Quasi Peak	Average	Peak	Average
0.009 – 0.090	148.5 – 128.5	NA	128.5 – 108.5**	82	62
0.090 – 0.110	NA	108.5 – 106.8**	NA		
0.110 – 0.490	126.8 – 113.8	NA	106.8 – 93.8**		
0.490 – 1.705	NA	73.8 – 63.0**	NA		
1.705 – 30.0*		69.5			
30 – 88		40.0			
88 – 216		43.5			
216 – 960		46.0			
960 - 1000		54.0			
Above 1000		74.0			

*- The limit for 3 m test distance was calculated using the inverse square distance extrapolation factor as follows:
$$Lim_{S_2} = Lim_{S_1} + 40 \log(S_1/S_2),$$

where S_1 and S_2 – standard defined and test distance respectively in meters.

**- The limit decreases linearly with the logarithm of frequency.

Note 1: The fundamental emission limit in dB(μV/m) was calculated as follows:

$$Lim_{AVR} = 20 \times \log(56.81818 \times F - 6136.3636) - \text{within } 130 - 174 \text{ MHz band;}$$

$$Lim_{AVR} = 20 \times \log(41.6667 \times F - 7083.3333) - \text{within } 260 - 470 \text{ MHz band,}$$

where F is the carrier frequency in MHz.

The limit for spurious emissions was 20 dB lower than fundamental emission limit.

The above limits provided in terms of average values, peak limit was 20 dB above the average limit.

Note 2: The above field strength limits applied from the lowest radio frequency generated in the device, without going below 9 kHz up to the tenth harmonic of the highest fundamental frequency.



Test specification:	FCC Part 15, Section 231(b) / RSS-210, Section A1.1.2, Field strength of emissions		
Test procedure:	ANSI C63.4, Section 13.1.4		
Test mode:	Compliance	Verdict:	PASS
Date(s):	6/9/2013 - 6/10/2013		
Temperature: 25.6 °C	Air Pressure: 1005 hPa	Relative Humidity: 41 %	Power Supply: 120 VAC
Remarks:			

7.2.2 Test procedure for spurious emission field strength measurements in 9 kHz to 30 MHz band

7.2.2.1 The EUT was set up as shown in Figure 7.2.1, energized and the performance check was conducted.

7.2.2.2 The specified frequency range was investigated with antenna connected to spectrum analyzer/ EMI receiver. To find maximum radiation the turntable was rotated 360° and the measuring antenna was rotated around its vertical axis.

7.2.2.3 The worst test results (the lowest margins) were recorded in Table 7.2.3, Table 7.2.5 and shown in the associated plots.

7.2.3 Test procedure for spurious emission field strength measurements above 30 MHz

7.2.3.1 The EUT was set up as shown in Figure 7.2.2, energized and the performance check was conducted.

7.2.3.2 The specified frequency range was investigated with antenna connected to spectrum analyzer/ EMI receiver. To find maximum radiation the turntable was rotated 360°, the measuring antenna height was changed from 1 to 4 m, its polarization was switched from vertical to horizontal.

7.2.3.3 The worst test results (the lowest margins) were recorded in Table 7.2.3, Table 7.2.5 and shown in the associated plots.

Figure 7.2.1 Setup for spurious emission field strength measurements below 30 MHz

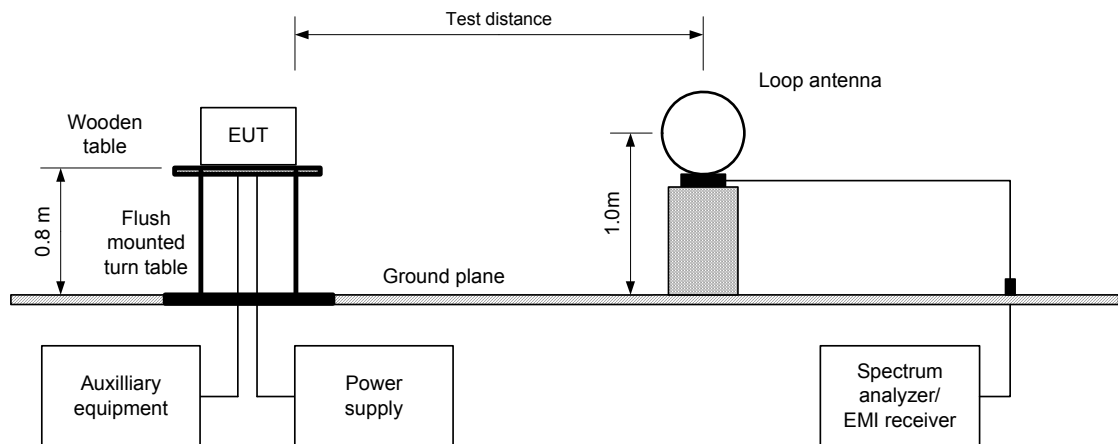



Test specification:	FCC Part 15, Section 231(b) / RSS-210, Section A1.1.2, Field strength of emissions		
Test procedure:	ANSI C63.4, Section 13.1.4		
Test mode:	Compliance	Verdict:	PASS
Date(s):	6/9/2013 - 6/10/2013		
Temperature: 25.6 °C	Air Pressure: 1005 hPa	Relative Humidity: 41 %	Power Supply: 120 VAC
Remarks:			

Figure 7.2.2 Setup for spurious emission field strength measurements above 30 MHz

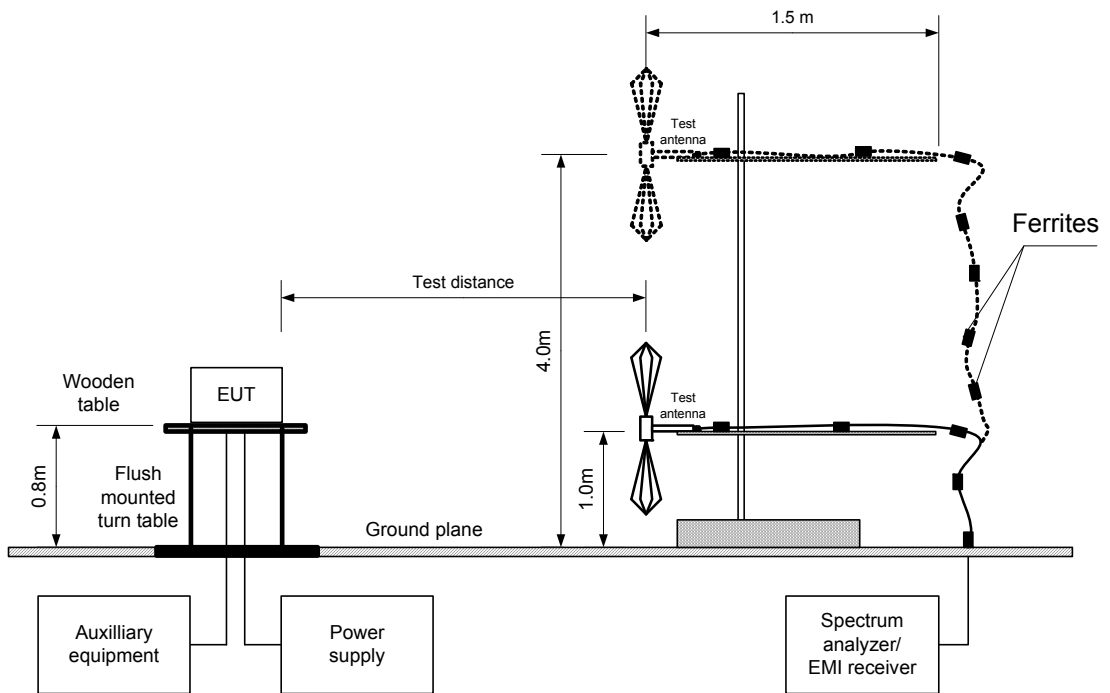



Test specification:	FCC Part 15, Section 231(b) / RSS-210, Section A1.1.2, Field strength of emissions		
Test procedure:	ANSI C63.4, Section 13.1.4		
Test mode:	Compliance	Verdict:	PASS
Date(s):	6/9/2013 - 6/10/2013		
Temperature: 25.6 °C	Air Pressure: 1005 hPa	Relative Humidity: 41 %	Power Supply: 120 VAC
Remarks:			

Table 7.2.3 Field strength of fundamental emission, spurious emissions outside restricted bands and within restricted bands at frequencies above 1 GHz

TEST DISTANCE: 3 m
 EUT POSITION: Typical (Vertical)
 MODULATION: FSK
 BIT RATE: 38.4kbps
 TRANSMITTER OUTPUT POWER SETTINGS: Maximum
 TRANSMITTER OUTPUT POWER: W
 INVESTIGATED FREQUENCY RANGE: 0.009 - 9200 MHz
 DETECTOR USED: Peak
 RESOLUTION BANDWIDTH: 0.2 kHz (9 kHz – 150 kHz)
 9.0 kHz (150 kHz – 30 MHz)
 120 kHz (30 MHz – 1000 MHz)
 1.0 MHz (above 1000 MHz)
 VIDEO BANDWIDTH: ≥ Resolution bandwidth
 TEST ANTENNA TYPE: Active loop (9 kHz – 30 MHz)
 Biconilog (30 MHz – 1000 MHz)
 Double ridged guide (above 1000 MHz)

F, MHz	Antenna		Azimuth, degrees*	Peak field strength			Average field strength				Verdict
	Pol.	Height, m		Measured, dB(μV/m)	Limit, dB(μV/m)	Margin, dB**	Measured, dB(μV/m)	Calculated, dB(μV/m)	Limit, dB(μV/m)	Margin, dB**	
Fundamental emission***											
916.5150	V	1.0	225	101.0	102.0	-1.0	101.0	79.07	82.0	-2.93	Pass
Spurious emissions											
1833.025	V	1.2	175	58.06	82.0	-23.94	57.45	35.52	62.0	-26.48	Pass

*- EUT front panel refers to 0 degrees position of turntable.
 **- Margin, dB = Measured (calculated) value, dB(μV/m) - Limit, dB(μV/m)
 *** Max value was obtained at Unom and 85%Unom input power voltage.

Table 7.2.4 Average factor calculation

Transmission pulse		Transmission burst		Transmission train duration, ms	Average factor, dB
Duration, ms	Period, ms	Duration, ms	Period, ms		
8	>100	NA	NA	NA	-21.93

*- Average factor was calculated as follows
 for pulse train shorter than 100 ms: $Average\ factor = 20 \times \log_{10} \left(\frac{Pulse\ duration}{Pulse\ period} \times \frac{Burst\ duration}{Train\ duration} \times Number\ of\ bursts\ within\ pulse\ train \right)$
 for pulse train longer than 100 ms: $Average\ factor = 20 \times \log_{10} \left(\frac{Pulse\ duration}{Pulse\ period} \times \frac{Burst\ duration}{100\ ms} \times Number\ of\ bursts\ within\ 100\ ms \right)$

Reference numbers of test equipment used

HL 0446	HL 0604	HL 1984	HL 2780	HL 2871	HL 3818	HL 4160	HL 4353
---------	---------	---------	---------	---------	---------	---------	---------

Full description is given in Appendix A.



Test specification:	FCC Part 15, Section 231(b) / RSS-210, Section A1.1.2, Field strength of emissions		
Test procedure:	ANSI C63.4, Section 13.1.4		
Test mode:	Compliance	Verdict: PASS	
Date(s):	6/9/2013 - 6/10/2013		
Temperature: 25.6 °C	Air Pressure: 1005 hPa	Relative Humidity: 41 %	Power Supply: 120 VAC
Remarks:			

Table 7.2.5 Field strength of emissions below 1 GHz within restricted bands

TEST DISTANCE: 3 m
 EUT POSITION: Typical (Vertical)
 MODULATION: FSK
 BIT RATE: 38.4kbps
 TRANSMITTER OUTPUT POWER SETTINGS: Maximum
 INVESTIGATED FREQUENCY RANGE: 0.009 – 1000 MHz
 DETECTOR USED: Peak
 RESOLUTION BANDWIDTH: 0.2 kHz (9 kHz – 150 kHz)
 9.0 kHz (150 kHz – 30 MHz)
 120 kHz (30 MHz – 1000 MHz)
 VIDEO BANDWIDTH: ≥ Resolution bandwidth
 TEST ANTENNA TYPE: Active loop (9 kHz – 30 MHz)
 Biconilog (30 MHz – 1000 MHz)

Frequency, MHz	Peak emission, dB(µV/m)	Quasi-peak			Antenna polarization	Antenna height, m	Turn-table position**, degrees	Verdict
		Measured emission, dB(µV/m)	Limit, dB(µV/m)	Margin, dB*				
No emissions were found								Pass

*- Margin = Measured emission - specification limit.
 **- EUT front panel refer to 0 degrees position of turntable.

Reference numbers of test equipment used

HL 0446	HL 0604	HL 2780	HL 2871	HL 4353			
---------	---------	---------	---------	---------	--	--	--

Full description is given in Appendix A. HL 3818



Test specification:	FCC Part 15, Section 231(b) / RSS-210, Section A1.1.2, Field strength of emissions		
Test procedure:	ANSI C63.4, Section 13.1.4		
Test mode:	Compliance	Verdict:	PASS
Date(s):	6/9/2013 - 6/10/2013		
Temperature: 25.6 °C	Air Pressure: 1005 hPa	Relative Humidity: 41 %	Power Supply: 120 VAC
Remarks:			

Table 7.2.6 Restricted bands according to FCC 15, Section 205

MHz	MHz	MHz	MHz	MHz	GHz
0.09 - 0.11	8.37625 - 8.38675	73 - 74.6	399.9 - 410	2690 - 2900	10.6 - 12.7
0.495 - 0.505	8.41425 - 8.41475	74.8 - 75.2	608 - 614	3260 - 3267	13.25 - 13.4
2.1735 - 2.1905	12.290 - 12.293	108 - 121.94	960 - 1240	3332 - 3339	14.47 - 14.5
4.125 - 4.128	12.51975 - 12.52025	123 - 138	1300 - 1427	3345.8 - 3358	15.35 - 16.2
4.17725 - 4.17775	12.57675 - 12.57725	149.9 - 150.05	1435 - 1626.5	3600 - 4400	17.7 - 21.4
4.20725 - 4.20775	13.36 - 13.41	156.52475 - 156.52525	1645.5 - 1646.5	4500 - 5150	22.01 - 23.12
6.215 - 6.218	16.420 - 16.423	156.7 - 156.9	1660 - 1710	5350 - 5460	23.6 - 24
6.26775 - 6.26825	16.69475 - 16.69525	162.0125 - 167.17	1718.8 - 1722.2	7250 - 7750	31.2 - 31.8
6.31175 - 6.31225	16.80425 - 16.80475	167.72 - 173.2	2200 - 2300	8025 - 8500	36.43 - 36.5
8.291 - 8.294	25.5 - 25.67	240 - 285	2310 - 2390	9000 - 9200	Above 38.6
8.362 - 8.366	37.5 - 38.25	322 - 335.4	2483.5 - 2500	9300 - 9500	

Table 7.2.7 Restricted bands according to RSS-Gen, Table 3

MHz	MHz	MHz	MHz	MHz	GHz
0.09 - 0.11	8.291 - 8.294	16.80425 - 16.80475	399.9 - 410	3260 - 3267	10.6 - 12.7
2.1735 - 2.190	8.362 - 8.366	25.5 - 25.67	608 - 614	3332 - 3339	13.25 - 13.4
3.020 - 3.026	8.37625 - 8.38675	37.5 - 38.25	960 - 1427	3345.8 - 3358	14.47 - 14.5
4.125 - 4.128	8.41425 - 8.41475	73 - 74.6	1435 - 1626.5	3500 - 4400	15.35 - 16.2
4.17725 - 4.17775	12.290 - 12.293	74.8 - 75.2	1645.5 - 1646.5	4500 - 5150	17.7 - 21.4
4.20725 - 4.20775	12.51975 - 12.52025	108 - 138	1660 - 1710	5350 - 5460	22.01 - 23.12
5.677 - 5.683	12.57675 - 12.57725	156.52475 - 156.52525	1718.8 - 1722.2	7250 - 7750	23.6 - 24.0
6.215 - 6.218	13.36 - 13.41	156.7 - 156.9	2200 - 2300	8025 - 8500	31.2 - 31.8
6.26775 - 6.26825	16.42 - 16.423	240 - 285	2310 - 2390	9000 - 9200	36.43 - 36.5
6.31175 - 6.31225	16.69475 - 16.69525	322 - 335.4	2655 - 2900	9300 - 9500	Above 38.6



Test specification:	FCC Part 15, Section 231(b) / RSS-210, Section A1.1.2, Field strength of emissions		
Test procedure:	ANSI C63.4, Section 13.1.4		
Test mode:	Compliance	Verdict: PASS	
Date(s):	6/9/2013 - 6/10/2013		
Temperature: 25.6 °C	Air Pressure: 1005 hPa	Relative Humidity: 41 %	Power Supply: 120 VAC
Remarks:			

Plot 7.2.1 Radiated emission measurements at the fundamental frequency

TEST SITE: Semi anechoic chamber
TEST DISTANCE: 3 m
ANTENNA POLARIZATION: Vertical
EUT POSITION: Typical (Vertical)
INPUT VOLTAGE: Unom

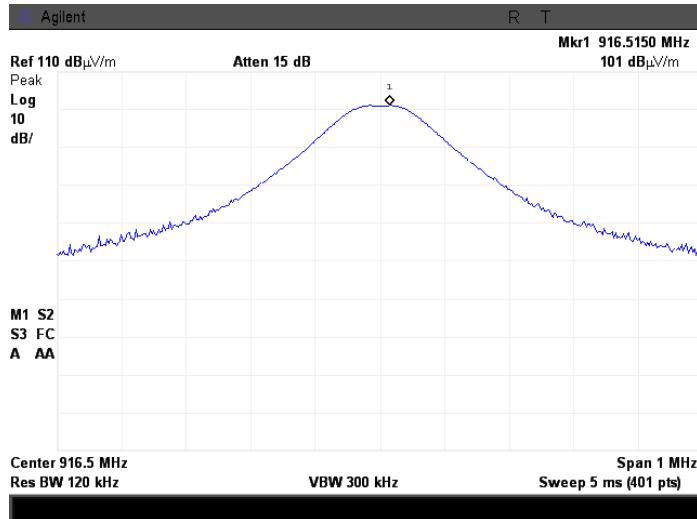

Plot 7.2.2 Radiated emission measurements at the fundamental frequency

TEST SITE: Semi anechoic chamber
TEST DISTANCE: 3 m
ANTENNA POLARIZATION: Horizontal
EUT POSITION: Typical (Vertical)
INPUT VOLTAGE: Unom

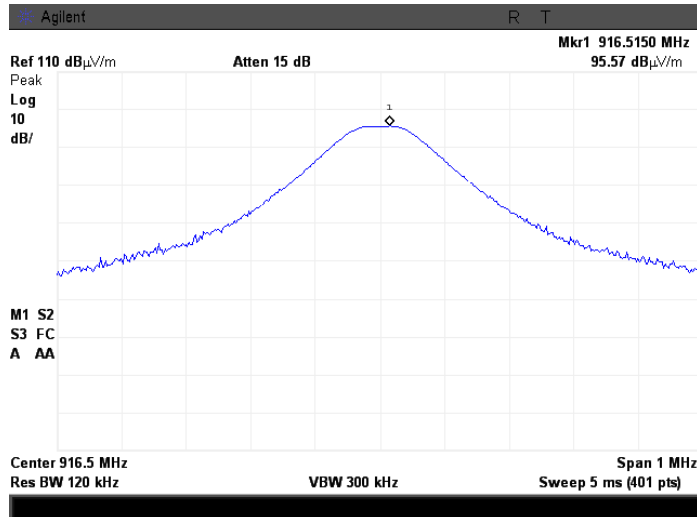



Test specification:	FCC Part 15, Section 231(b) / RSS-210, Section A1.1.2, Field strength of emissions		
Test procedure:	ANSI C63.4, Section 13.1.4		
Test mode:	Compliance	Verdict: PASS	
Date(s):	6/9/2013 - 6/10/2013		
Temperature: 25.6 °C	Air Pressure: 1005 hPa	Relative Humidity: 41 %	Power Supply: 120 VAC
Remarks:			

Plot 7.2.3 Radiated emission measurements at the fundamental frequency

TEST SITE: Semi anechoic chamber
 TEST DISTANCE: 3 m
 ANTENNA POLARIZATION: Vertical
 EUT POSITION: Typical (Vertical)
 INPUT VOLTAGE: 115%Unom

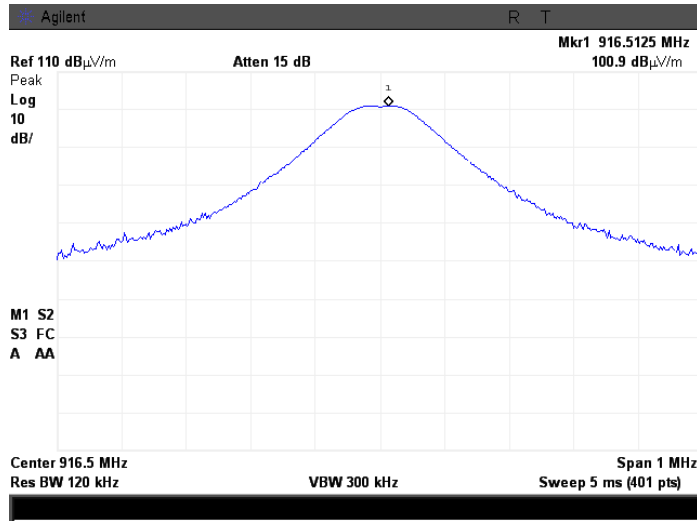

Plot 7.2.4 Radiated emission measurements at the fundamental frequency

TEST SITE: Semi anechoic chamber
 TEST DISTANCE: 3 m
 ANTENNA POLARIZATION: Horizontal
 EUT POSITION: Typical (Vertical)
 INPUT VOLTAGE: 115%Unom

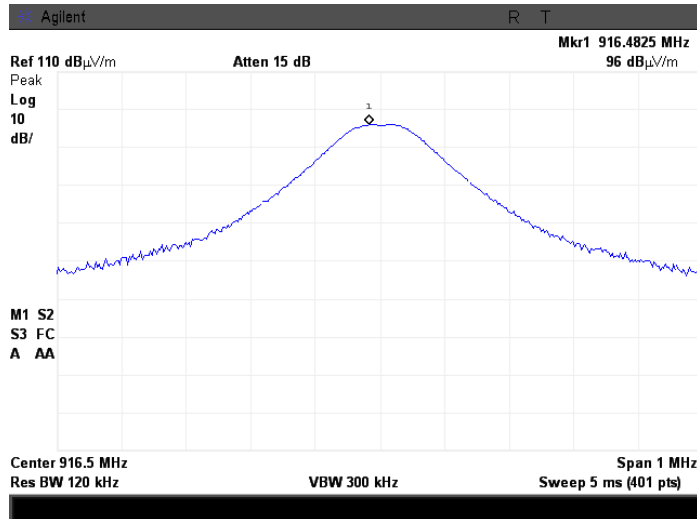



Test specification:	FCC Part 15, Section 231(b) / RSS-210, Section A1.1.2, Field strength of emissions		
Test procedure:	ANSI C63.4, Section 13.1.4		
Test mode:	Compliance	Verdict: PASS	
Date(s):	6/9/2013 - 6/10/2013		
Temperature: 25.6 °C	Air Pressure: 1005 hPa	Relative Humidity: 41 %	Power Supply: 120 VAC
Remarks:			

Plot 7.2.5 Radiated emission measurements at the fundamental frequency

TEST SITE: Semi anechoic chamber
 TEST DISTANCE: 3 m
 ANTENNA POLARIZATION: Vertical
 EUT POSITION: Typical (Vertical)
 INPUT VOLTAGE: 85%Unom

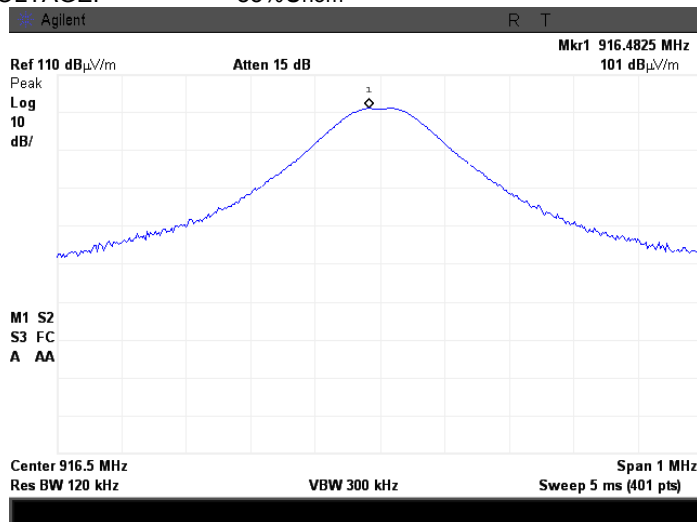

Plot 7.2.6 Radiated emission measurements at the fundamental frequency

TEST SITE: Semi anechoic chamber
 TEST DISTANCE: 3 m
 ANTENNA POLARIZATION: Horizontal
 EUT POSITION: Typical (Vertical)
 INPUT VOLTAGE: 85%Unom

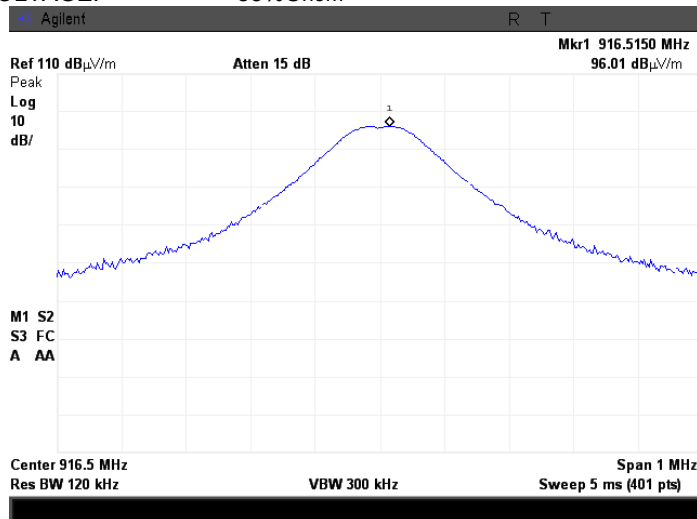



Test specification:	FCC Part 15, Section 231(b) / RSS-210, Section A1.1.2, Field strength of emissions		
Test procedure:	ANSI C63.4, Section 13.1.4		
Test mode:	Compliance	Verdict: PASS	
Date(s):	6/9/2013 - 6/10/2013		
Temperature: 25.6 °C	Air Pressure: 1005 hPa	Relative Humidity: 41 %	Power Supply: 120 VAC
Remarks:			

Plot 7.2.7 Radiated emission measurements from 9 to 150 kHz

TEST SITE: Semi anechoic chamber
 TEST DISTANCE: 3 m
 ANTENNA POLARIZATION: Vertical
 EUT POSITION: Typical (Vertical)



ACTV DET: PEAK
 MEAS DET: PEAK QP AVG
 NKR 9.0 kHz
 60.20 dBµV/m

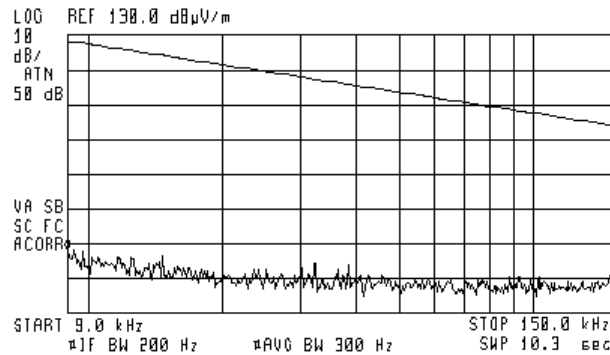

Plot 7.2.8 Radiated emission measurements from 0.15 to 30 MHz

TEST SITE: Semi anechoic chamber
 TEST DISTANCE: 3 m
 ANTENNA POLARIZATION: Vertical
 EUT POSITION: Typical (Vertical)



ACTV DET: PEAK
 MEAS DET: PEAK QP AVG
 NKR 150 kHz
 60.26 dBµV/m

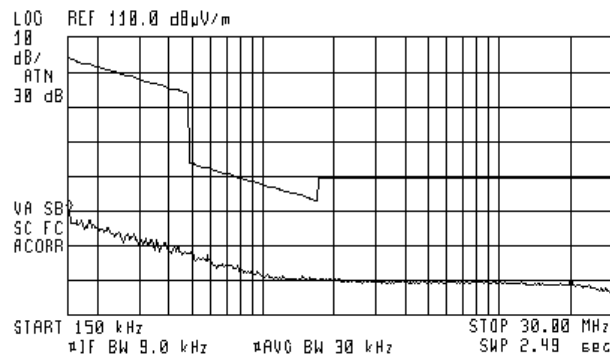



Test specification:	FCC Part 15, Section 231(b) / RSS-210, Section A1.1.2, Field strength of emissions		
Test procedure:	ANSI C63.4, Section 13.1.4		
Test mode:	Compliance	Verdict: PASS	
Date(s):	6/9/2013 - 6/10/2013		
Temperature: 25.6 °C	Air Pressure: 1005 hPa	Relative Humidity: 41 %	Power Supply: 120 VAC
Remarks:			

Plot 7.2.9 Radiated emission measurements from 30 to 1000 MHz

TEST SITE: Semi anechoic chamber
 TEST DISTANCE: 3 m
 ANTENNA POLARIZATION: Vertical and Horizontal
 EUT POSITION: Typical (Vertical)

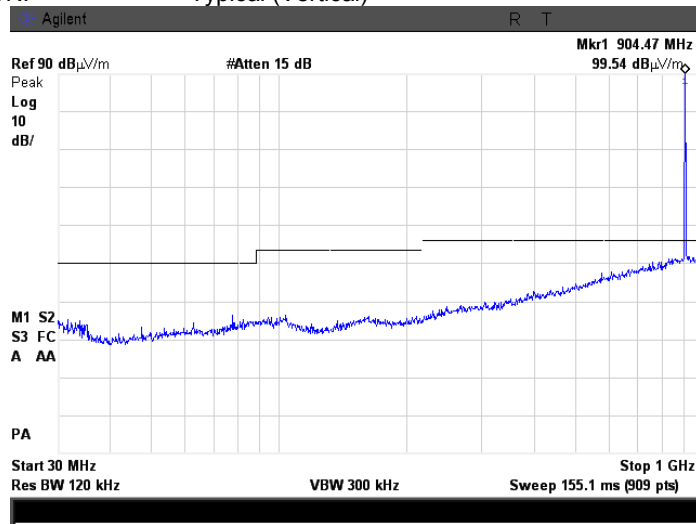

Plot 7.2.10 Radiated emission measurements from 1000 to 9200 MHz

TEST SITE: Semi anechoic chamber
 TEST DISTANCE: 3 m
 ANTENNA POLARIZATION: Vertical and Horizontal
 EUT POSITION: Typical (Vertical)

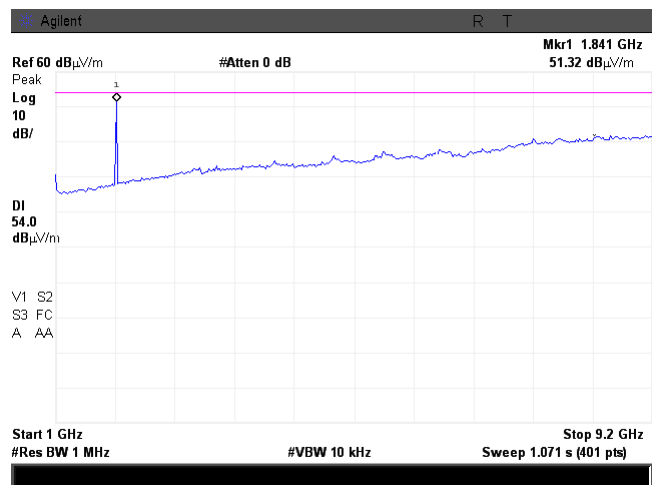
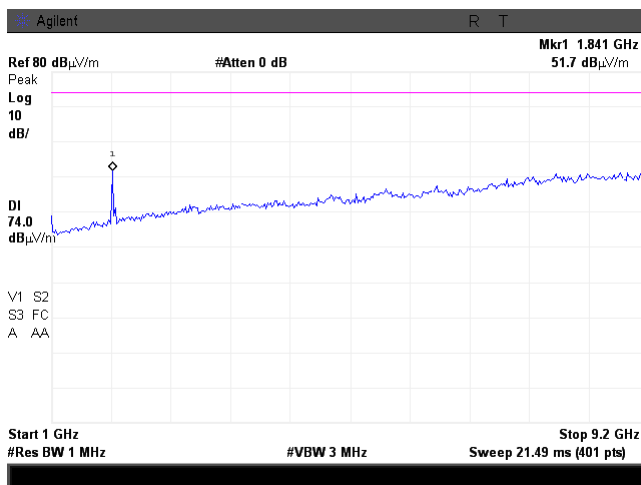



Test specification: FCC Part 15, Section 231(b) / RSS-210, Section A1.1.2, Field strength of emissions			
Test procedure: ANSI C63.4, Section 13.1.4			
Test mode: Compliance	Verdict: PASS		
Date(s): 6/9/2013 - 6/10/2013			
Temperature: 25.6 °C	Air Pressure: 1005 hPa	Relative Humidity: 41 %	Power Supply: 120 VAC
Remarks:			

Plot 7.2.11 Radiated emission measurements at the second harmonic frequency

TEST SITE: Semi anechoic chamber
TEST DISTANCE: 3 m
ANTENNA POLARIZATION: Vertical
EUT POSITION: Typical (Vertical)

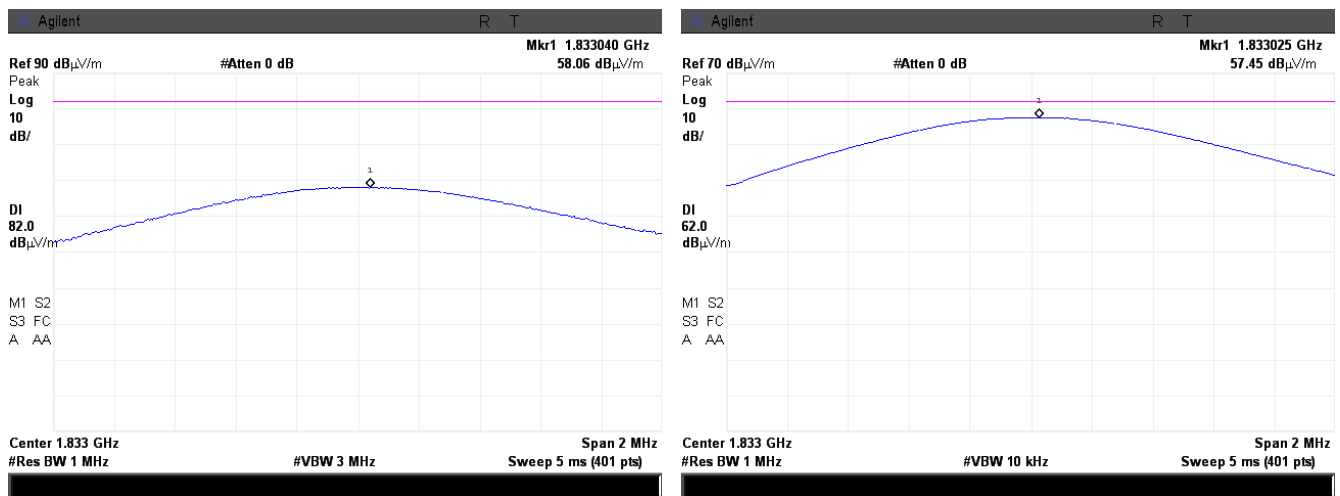

Plot 7.2.12 Radiated emission measurements at the second harmonic frequency

TEST SITE: Semi anechoic chamber
TEST DISTANCE: 3 m
ANTENNA POLARIZATION: Horizontal
EUT POSITION: Typical (Vertical)

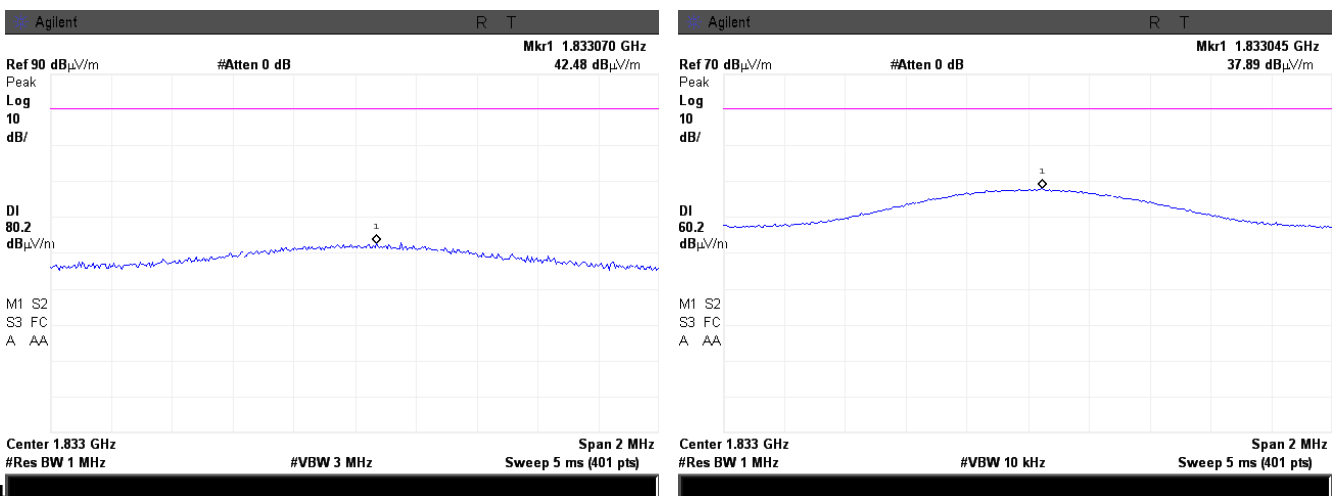

4



Test specification:	FCC Part 15, Section 231(b) / RSS-210, Section A1.1.2, Field strength of emissions		
Test procedure:	ANSI C63.4, Section 13.1.4		
Test mode:	Compliance	Verdict: PASS	
Date(s):	6/9/2013 - 6/10/2013		
Temperature: 25.6 °C	Air Pressure: 1005 hPa	Relative Humidity: 41 %	Power Supply: 120 VAC
Remarks:			

Plot 7.2.13 Transmission pulse duration

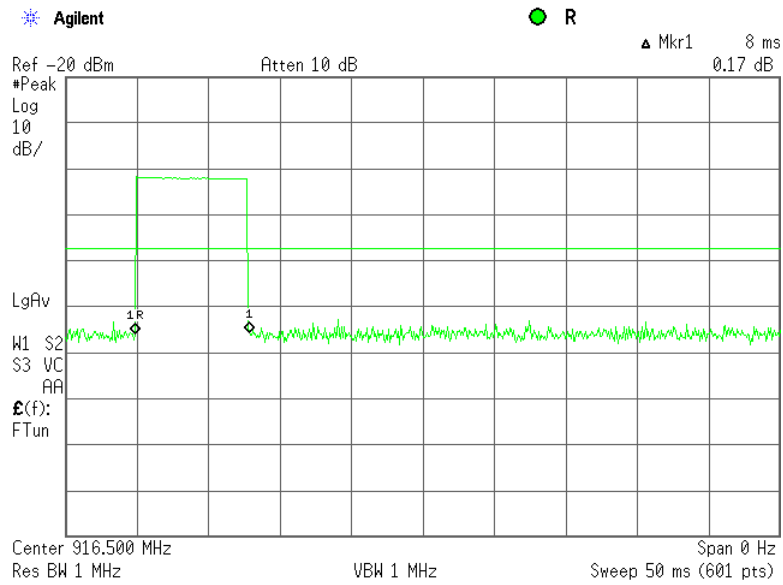

Plot 7.2.14 Transmission pulse period

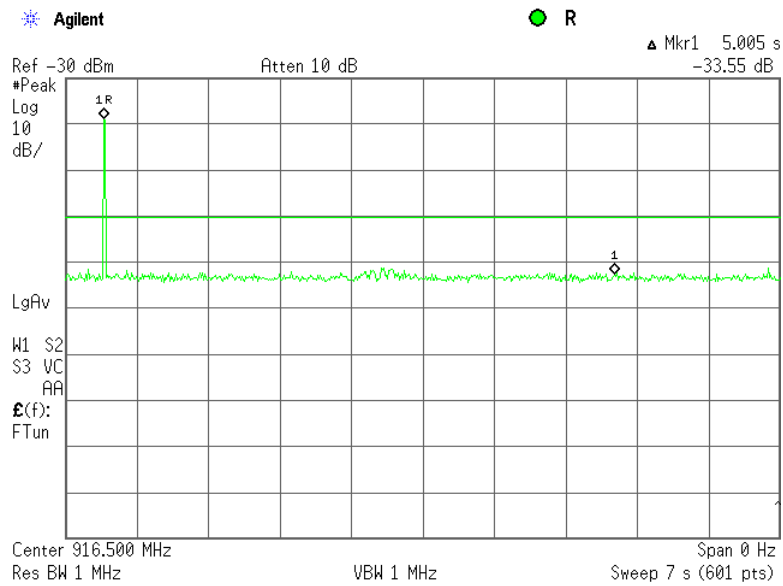



Test specification:	FCC Part 15, Section 231(c) / RSS-210, Section A1.1.3, Occupied bandwidth		
Test procedure:	ANSI C63.4, Section 13.1.7		
Test mode:	Compliance	Verdict:	PASS
Date(s):	6/9/2013		
Temperature: 23 °C	Air Pressure: 1005 hPa	Relative Humidity: 35 %	Power Supply: 120 VAC
Remarks:			

7.3 Occupied bandwidth test

7.3.1 General

This test was performed to measure transmitter occupied bandwidth. Specification test limits are given in Table 7.3.1. The test results are provided in Table 7.3.2 and associated plots.

Table 7.3.1 Occupied bandwidth limits

Assigned frequency, MHz	Modulation envelope reference points*, dBc	Maximum allowed bandwidth, % of the carrier frequency
70 - 900	20.0	0.25
Above 900		0.50

*- Modulation envelope reference points provided in terms of attenuation below modulated carrier.

7.3.2 Test procedure

7.3.2.1 The EUT was set up as shown in Figure 7.3.1, energized and its proper operation was checked.

7.3.2.2 The EUT was set to transmit modulated carrier.

7.3.2.3 The transmitter occupied bandwidth was measured with spectrum analyzer as frequency delta between reference points on modulation envelope and provided in Table 7.3.2 and associated plot.

Figure 7.3.1 Occupied bandwidth test setup





Test specification:		FCC Part 15, Section 231(c) / RSS-210, Section A1.1.3, Occupied bandwidth	
Test procedure:		ANSI C63.4, Section 13.1.7	
Test mode:		Compliance	
Date(s):		6/9/2013	
Temperature: 23 °C		Air Pressure: 1005 hPa	
Relative Humidity: 35 %		Power Supply: 120 VAC	
Remarks:			

Table 7.3.2 Occupied bandwidth test results

DETECTOR USED: Peak hold
 RESOLUTION BANDWIDTH: 10kHz
 VIDEO BANDWIDTH: 30kHz
 MODULATION ENVELOPE REFERENCE POINTS: 20 dBc
 MODULATION: FSK
 BIT RATE: 38.4kbps

Carrier frequency, MHz	Occupied bandwidth, kHz	Limit		Margin, kHz	Verdict
		% of the carrier frequency	kHz		
916.5	88.95	0.5	4582.5	-4493.55	Pass

99% power OBW: 81.41 kHz

Reference numbers of test equipment used

HL 3818							
---------	--	--	--	--	--	--	--

Full description is given in Appendix A.

Plot 7.3.1 Occupied bandwidth test result

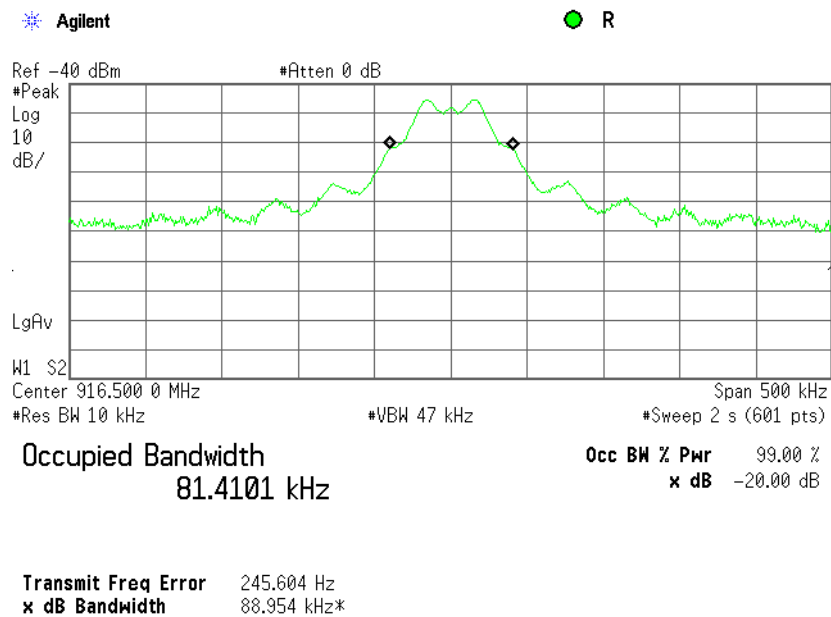



Test specification:	FCC section 15.207(a), RSS-Gen section 7.2.4, Conducted emission		
Test procedure:	ANSI C63.4, Section 13.1.3		
Test mode:	Compliance	Verdict:	PASS
Date(s):	6/10/2013		
Temperature: 24.4 °C	Air Pressure: 1010 hPa	Relative Humidity: 38 %	Power Supply: 120 VAC
Remarks:			

7.4 Conducted emissions

7.4.1 General

This test was performed to measure common mode conducted emissions at the power port. Specification test limits are given in Table 7.4.1.

Table 7.4.1 Limits for conducted emissions

Frequency, MHz	Class B limit, dB(μV)	
	QP	AVRG
0.15 - 0.5	66 - 56*	56 - 46*
0.5 - 5.0	56	46
5.0 - 30	60	50

* - The limit decreases linearly with the logarithm of frequency.

7.4.2 Test procedure

7.4.2.1 The EUT was set up as shown in Figure 7.4.1, energized and the performance check was conducted.

7.4.2.2 The measurements were performed at power terminals with the LISN, connected to a spectrum analyzer while unused coaxial connector of the LISN was terminated with 50 Ohm.

7.4.2.3 The position of the device cables was varied to determine maximum emission level.

7.4.2.4 The worst test results (the lowest margins) were recorded in Table 7.4.2 and shown in the associated plots.



Test specification:	FCC section 15.207(a), RSS-Gen section 7.2.4, Conducted emission		
Test procedure:	ANSI C63.4, Section 13.1.3		
Test mode:	Compliance	Verdict:	PASS
Date(s):	6/10/2013		
Temperature: 24.4 °C	Air Pressure: 1010 hPa	Relative Humidity: 38 %	Power Supply: 120 VAC
Remarks:			

Figure 7.4.1 Setup for conducted emission measurements, table-top equipment

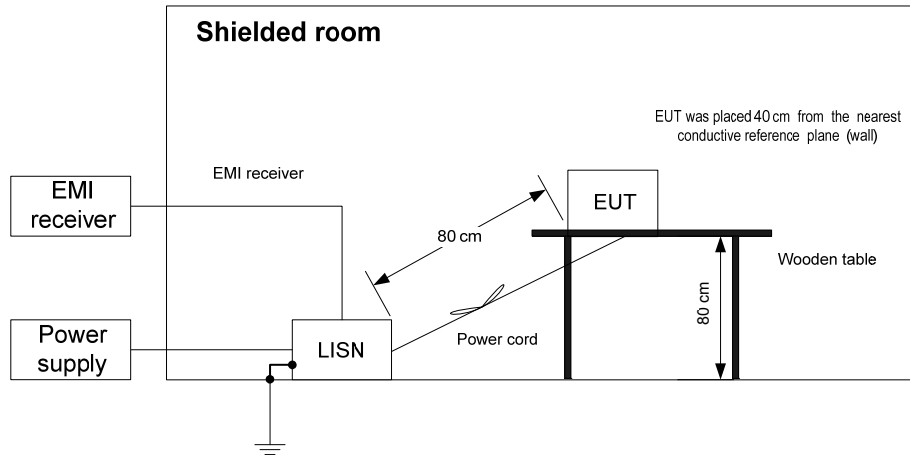



Test specification:		FCC section 15.207(a), RSS-Gen section 7.2.4, Conducted emission	
Test procedure:		ANSI C63.4, Section 13.1.3	
Test mode:		Compliance	
Date(s):		6/10/2013	
Temperature: 24.4 °C		Air Pressure: 1010 hPa	
		Relative Humidity: 38 %	
		Power Supply: 120 VAC	
Remarks:			

Table 7.4.2 Conducted emission test results

LINE: AC mains
EUT OPERATING MODE: Transmit
EUT SET UP: TABLE-TOP
TEST SITE: SHIELDED ROOM
FREQUENCY RANGE: 150 kHz - 30 MHz
RESOLUTION BANDWIDTH: 9 kHz

Frequency, MHz	Peak emission, dB(µV)	Quasi-peak			Average			Line ID	Verdict
		Measured emission, dB(µV)	Limit, dB(µV)	Margin, dB*	Measured emission, dB(µV)	Limit, dB(µV)	Margin, dB*		
0.163423	43.40	40.49	65.35	-24.86	26.88	55.35	-28.47	L1	Pass
0.192243	38.15	36.15	63.95	-27.80	25.14	53.95	-28.81		
0.380740	35.95	34.01	58.29	-24.28	23.87	48.29	-24.42		
0.187610	38.98	34.66	64.17	-29.51	19.25	54.17	-34.92	L2	Pass
0.198300	36.96	34.24	63.72	-29.48	16.76	53.72	-36.96		
0.368965	31.42	28.56	58.57	-30.01	20.24	48.57	-28.33		

*- Margin = Measured emission - specification limit.

Reference numbers of test equipment used

HL 0163	HL 0787	HL 1425	HL 1513	HL 3612			
---------	---------	---------	---------	---------	--	--	--

Full description is given in Appendix A.



Test specification: FCC section 15.207(a), RSS-Gen section 7.2.4, Conducted emission			
Test procedure: ANSI C63.4, Section 13.1.3			
Test mode: Compliance	Verdict: PASS		
Date(s): 6/10/2013			
Temperature: 24.4 °C	Air Pressure: 1010 hPa	Relative Humidity: 38 %	Power Supply: 120 VAC
Remarks:			

Plot 7.4.1 Conducted emission measurements

LINE: L1
EUT OPERATING MODE: Transmit
LIMIT: QUASI-PEAK, AVERAGE
DETECTOR: PEAK



ACTV DET: PEAK
MEAS DET: PEAK QP AVG
MKR 170 kHz
41.81 dBµV

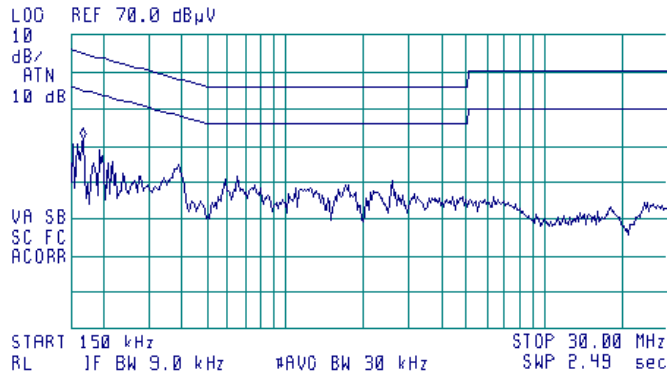

Plot 7.4.2 Conducted emission measurements

LINE: L2
EUT OPERATING MODE: Transmit
LIMIT: QUASI-PEAK, AVERAGE
DETECTOR: PEAK



ACTV DET: PEAK
MEAS DET: PEAK QP AVG
MKR 180 kHz
37.27 dBµV

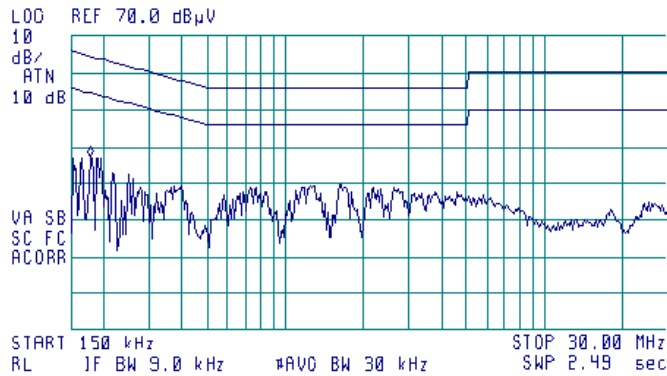



Test specification:	FCC Part 15, Section 203 / RSS-Gen, Section 7.1.2, Antenna requirements		
Test procedure:	Visual inspection / supplier declaration		
Test mode:	Compliance	Verdict:	PASS
Date(s):	6/10/2013		
Temperature: 24.3 °C	Air Pressure: 1010 hPa	Relative Humidity: 36 %	Power Supply: 120 VAC
Remarks:			

7.5 Antenna requirements

The EUT was verified for compliance with antenna requirements. A transmitter shall be designed to ensure that no antenna other than that furnished by the responsible party will be used with the device. It may be either permanently attached or employs a unique antenna connector for every antenna proposed for use with the EUT. This requirement does not apply to professionally installed transmitters. The rationale for compliance with the above requirements was either visual inspection results or supplier declaration. The summary of results is provided in Table 7.5.1.

Table 7.5.1 Antenna requirements

Requirement	Rationale	Verdict
The transmitter antenna is permanently attached	Visual inspection	Comply
The transmitter employs a unique antenna connector	NA	
The transmitter requires professional installation	NA	

Photograph 7.5.1 Antenna assembly





Test specification: FCC section 15.107, ICES-03 class B, conducted emission at AC power port	
Test procedure: ANSI C63.4, Sections 11.5 and 12.1.3 / CISPR 22	
Test mode: Compliance	Verdict: PASS
Date(s): 6/10/2013	
Temperature: 24.4 °C	Air Pressure: 1010 hPa
Relative Humidity: 38 %	
Power Supply: 120 VAC	
Remarks:	

8 Unintentional emissions

8.1 Conducted emissions

8.1.1 General

This test was performed to measure common mode conducted emissions at the mains power port. Specification test limits are given in Table 8.1.1.

Table 8.1.1 Limits for conducted emissions

Frequency, MHz	Class B limit, dB(μV)		Class A limit, dB(μV)	
	QP	AVRG	QP	AVRG
0.15 - 0.5	66 - 56*	56 - 46*	79	66
0.5 - 5.0	56	46	73	60
5.0 - 30	60	50	73	60

* - The limit decreases linearly with the logarithm of frequency.

8.1.2 Test procedure

8.1.2.1 The EUT was set up as shown in Figure 8.1.1 and associated photographs, energized and the performance check was conducted.

8.1.2.2 The measurements were performed at power terminals with the LISN, connected to a spectrum analyzer while unused coaxial connector of the LISN was terminated with 50 Ohm.

8.1.2.3 The position of the device cables was varied to determine maximum emission level.

8.1.2.4 The worst test results (the lowest margins) were recorded in Table 8.1.2 and shown in the associated plots.

Figure 8.1.1 Setup for conducted emission measurements, table-top equipment

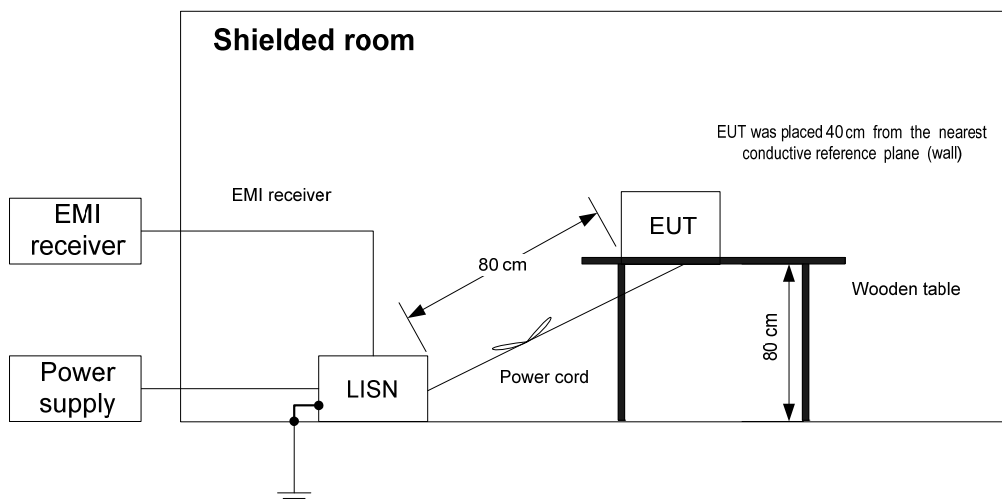



HERMON LABORATORIES

Test specification:	FCC section 15.107, ICES-03 class B, conducted emission at AC power port		
Test procedure:	ANSI C63.4, Sections 11.5 and 12.1.3 / CISPR 22		
Test mode:	Compliance	Verdict:	PASS
Date(s):	6/10/2013		
Temperature: 24.4 °C	Air Pressure: 1010 hPa	Relative Humidity: 38 %	Power Supply: 120 VAC
Remarks:			

Photograph 8.1.1 Setup for conducted emission measurements



Photograph 8.1.2 Setup for conducted emission measurements





Test specification:		FCC section 15.107, ICES-03 class B, conducted emission at AC power port			
Test procedure:		ANSI C63.4, Sections 11.5 and 12.1.3 / CISPR 22			
Test mode:		Compliance		Verdict: PASS	
Date(s):		6/10/2013			
Temperature: 24.4 °C		Air Pressure: 1010 hPa		Relative Humidity: 38 %	
Power Supply: 120 VAC		Remarks:			

Table 8.1.2 Conducted emission test results

LINE: AC mains
EUT OPERATING MODE: Stand-by and receive
EUT SET UP: TABLE-TOP
TEST SITE: SHIELDED ROOM
FREQUENCY RANGE: 150 kHz - 30 MHz
RESOLUTION BANDWIDTH: 9 kHz

Frequency, MHz	Peak emission, dB(µV)	Quasi-peak			Average			Line ID	Verdict
		Measured emission, dB(µV)	Limit, dB(µV)	Margin, dB*	Measured emission, dB(µV)	Limit, dB(µV)	Margin, dB*		
0.163423	43.40	40.49	65.35	-24.86	26.88	55.35	-28.47	L1	Pass
0.192243	38.15	36.15	63.95	-27.80	25.14	53.95	-28.81		
0.380740	35.95	34.01	58.29	-24.28	23.87	48.29	-24.42		
0.187610	38.98	34.66	64.17	-29.51	19.25	54.17	-34.92	L2	Pass
0.198300	36.96	34.24	63.72	-29.48	16.76	53.72	-36.96		
0.368965	31.42	28.56	58.57	-30.01	20.24	48.57	-28.33		

*- Margin = Measured emission - specification limit.

Reference numbers of test equipment used

HL 0163	HL 0787	HL 1425	HL 1513	HL 3612			
---------	---------	---------	---------	---------	--	--	--

Full description is given in Appendix A.



HERMON LABORATORIES

Test specification: FCC section 15.107, ICES-03 class B, conducted emission at AC power port			
Test procedure: ANSI C63.4, Sections 11.5 and 12.1.3 / CISPR 22			
Test mode: Compliance	Verdict: PASS		
Date(s): 6/10/2013			
Temperature: 24.4 °C	Air Pressure: 1010 hPa	Relative Humidity: 38 %	Power Supply: 120 VAC
Remarks:			

Plot 8.1.1 Conducted emission measurements

LINE: L1
 LIMIT: Class B
 EUT OPERATING MODE: Stand-by and receive
 LIMIT: QUASI-PEAK, AVERAGE
 DETECTOR: PEAK

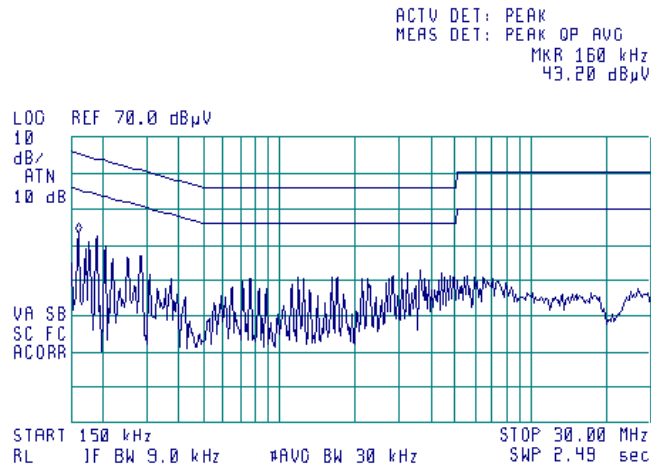

Plot 8.1.2 Conducted emission measurements

LINE: L2
 LIMIT: Class B
 EUT OPERATING MODE: Stand-by and receive
 LIMIT: QUASI-PEAK, AVERAGE
 DETECTOR: PEAK

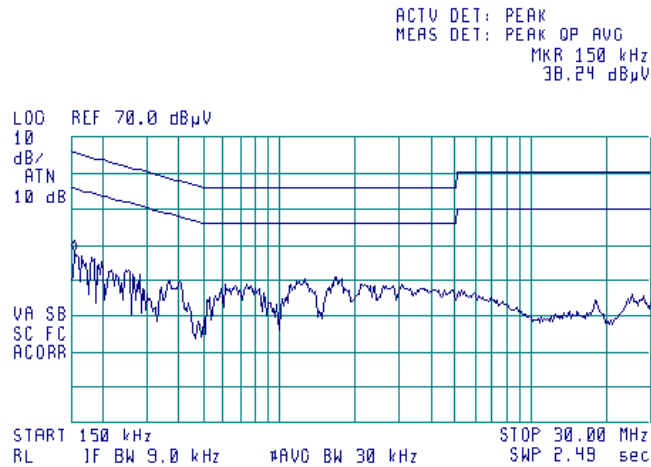



Test specification:		FCC Part 15, Section 109 / ICES-003 Class B, RSS-Gen Section 6.1, Radiated emission	
Test procedure:		ANSI C63.4, Sections 11.6 and 12.1.4 / RSS-Gen, Section 4.10 / CISPR 22	
Test mode:		Verdict: PASS	
Date(s):			
Temperature: 25.6 °C	Air Pressure: 1005 hPa	Relative Humidity: 41 %	Power Supply: 120 VAC
Remarks:			

8.2 Radiated emission measurements

8.2.1 General

This test was performed to measure radiated emissions from the EUT enclosure. Specification test limits are given in Table 8.2.1, Table 8.2.2.

Table 8.2.1 Radiated emission test limits according to FCC Part 15 Section 15.109 and ICES-003 section 6.2

Frequency, MHz	Class B limit, dB(µV/m)		Class A limit, dB(µV/m)	
	10 m distance	3 m distance	10 m distance	3 m distance
30 - 88	29.5*	40.0	39.0	49.5*
88 - 216	33.0*	43.5	43.5	54.0*
216 - 960	35.5*	46.0	46.4	56.9*
Above 960	43.5*	54.0	49.5	60.0*

* The limit for test distance other than specified was calculated using the inverse linear distance extrapolation factor as follows: $Lim_{S_2} = Lim_{S_1} + 20 \log(S_1/S_2)$, where S_1 and S_2 – standard defined and test distance respectively in meters.

Table 8.2.2 Radiated emission limits according to RSS-Gen, Section 6.1

Frequency, MHz	Field strength limit at 3 m test distance, dB(µV/m)
30 - 88	40.0
88 - 216	43.5
216 - 960	46.0
960 - 3 rd harmonic**	54.0

** - harmonic of the highest frequency the EUT generates, uses, operates or tunes to.

8.2.2 Test procedure

8.2.2.1 The EUT was set up as shown in Figure 8.2.1 and associated photographs, energized and the performance check was conducted.

8.2.2.2 The specified frequency range was investigated with biconilog antenna connected to EMI receiver. To find maximum radiation the turntable was rotated 360°, the measuring antenna height was changed from 1 to 4 m, its polarization was switched from vertical to horizontal and the EUT cables position was varied.

8.2.2.3 The worst test results (the lowest margins) were provided in the associated tables and plots.



Test specification:	FCC Part 15, Section 109 / ICES-003 Class B, RSS-Gen Section 6.1, Radiated emission		
Test procedure:	ANSI C63.4, Sections 11.6 and 12.1.4 / RSS-Gen, Section 4.10 / CISPR 22		
Test mode:	Compliance	Verdict:	PASS
Date(s):	6/9/2013		
Temperature: 25.6 °C	Air Pressure: 1005 hPa	Relative Humidity: 41 %	Power Supply: 120 VAC
Remarks:			

Figure 8.2.1 Setup for radiated emission measurements in anechoic chamber, table-top equipment

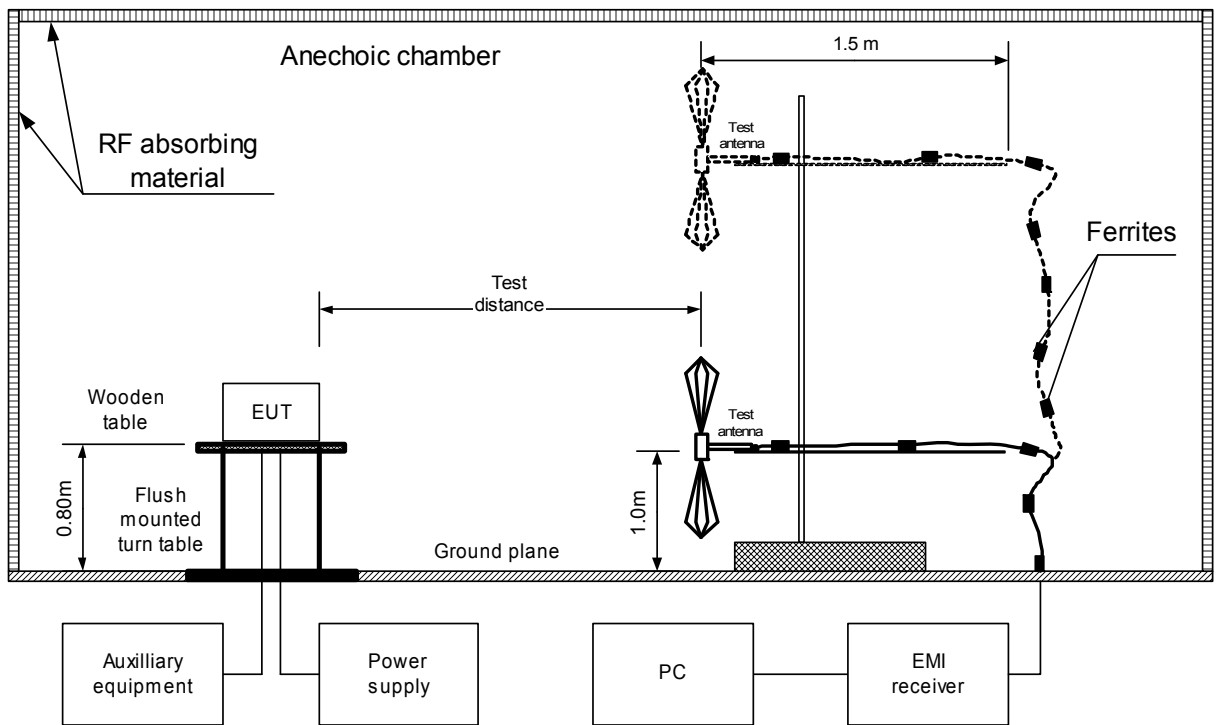



Test specification:	FCC Part 15, Section 109 / ICES-003 Class B, RSS-Gen Section 6.1, Radiated emission		
Test procedure:	ANSI C63.4, Sections 11.6 and 12.1.4 / RSS-Gen, Section 4.10 / CISPR 22		
Test mode:	Compliance	Verdict:	PASS
Date(s):	6/9/2013		
Temperature: 25.6 °C	Air Pressure: 1005 hPa	Relative Humidity: 41 %	Power Supply: 120 VAC
Remarks:			

Photograph 8.2.1 Setup for radiated emission measurements

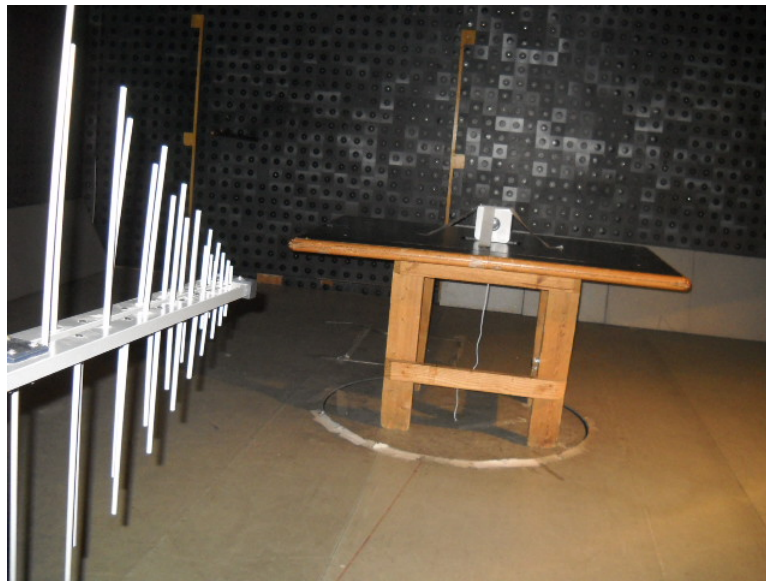

Photograph 8.2.2 Setup for radiated emission measurements

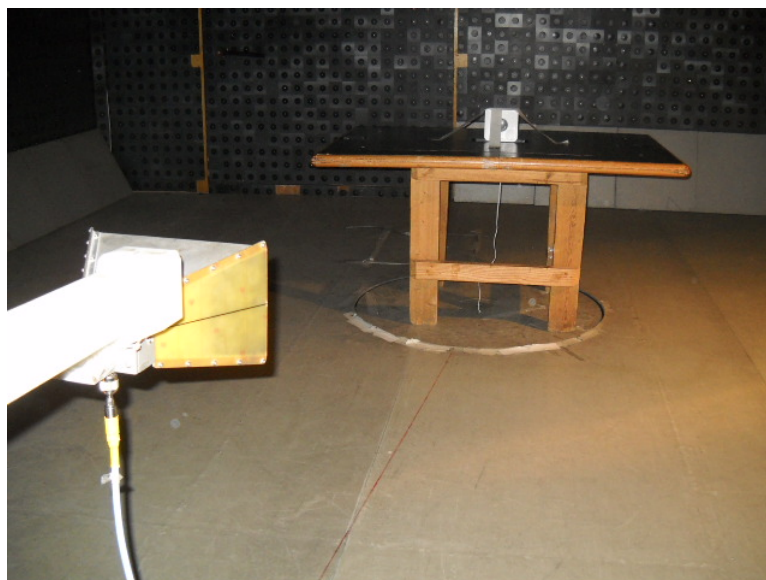



Test specification:		FCC Part 15, Section 109 / ICES-003 Class B, RSS-Gen Section 6.1, Radiated emission	
Test procedure:		ANSI C63.4, Sections 11.6 and 12.1.4 / RSS-Gen, Section 4.10 / CISPR 22	
Test mode:		Compliance	
Date(s):		6/9/2013	
Temperature: 25.6 °C		Air Pressure: 1005 hPa	
Remarks:		Relative Humidity: 41 %	
		Power Supply: 120 VAC	
		Verdict: PASS	

Table 8.2.3 Radiated emission test results

EUT SET UP: TABLE-TOP
LIMIT: Class B
EUT OPERATING MODE: Stand-by / Receive
TEST SITE: SEMI ANECHOIC CHAMBER
TEST DISTANCE: 3 m

DETECTORS USED: PEAK / QUASI-PEAK
FREQUENCY RANGE: 30 MHz – 1000 MHz
RESOLUTION BANDWIDTH: 120 kHz

Frequency, MHz	Peak emission, dB(µV/m)	Quasi-peak			Antenna polarization	Antenna height, m	Turn-table position**, degrees	Verdict
		Measured emission, dB(µV/m)	Limit, dB(µV/m)	Margin, dB*				
No emissions were found								Pass

DETECTORS USED: PEAK / AVERAGE
FREQUENCY RANGE: 1000 MHz – 4600 MHz
RESOLUTION BANDWIDTH: 1000 kHz

Frequency, MHz	Peak			Average			Antenna polarization	Antenna height, m	Turn-table position**, degrees	Verdict
	Measured emission, dB(µV/m)	Limit, dB(µV/m)	Margin, dB*	Measured emission, dB(µV/m)	Limit, dB(µV/m)	Margin, dB*				
No emissions were found										Pass

*- Margin = Measured emission - specification limit.
**- EUT front panel refer to 0 degrees position of turntable.

Reference numbers of test equipment used

HL 0521	HL 0604	HL 1984	HL 2871	HL 4160	HL 4353		
---------	---------	---------	---------	---------	---------	--	--

Full description is given in Appendix A.



Test specification:		FCC Part 15, Section 109 / ICES-003 Class B, RSS-Gen Section 6.1, Radiated emission	
Test procedure:		ANSI C63.4, Sections 11.6 and 12.1.4 / RSS-Gen, Section 4.10 / CISPR 22	
Test mode:		Verdict: PASS	
Date(s):		6/9/2013	
Temperature: 25.6 °C	Air Pressure: 1005 hPa	Relative Humidity: 41 %	Power Supply: 120 VAC
Remarks:			

Plot 8.2.1 Radiated emission measurements in 30 - 1000 MHz range, vertical antenna polarization

TEST SITE: Semi anechoic chamber
LIMIT: Class B
TEST DISTANCE: 3 m
EUT OPERATING MODE: Stand-by / Receive

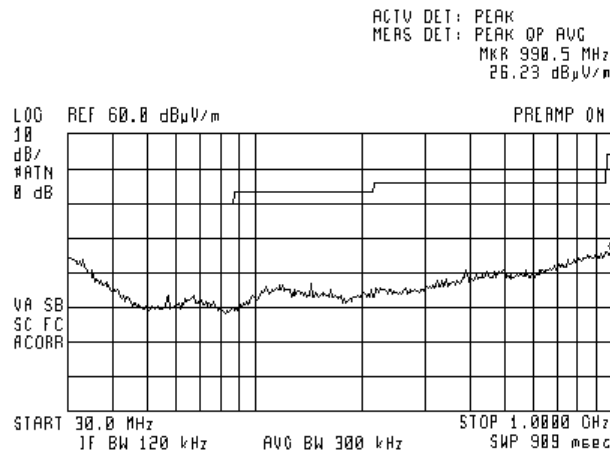

Plot 8.2.2 Radiated emission measurements in 30 - 1000 MHz range, horizontal antenna polarization

TEST SITE: Semi anechoic chamber
LIMIT: Class B
TEST DISTANCE: 3 m
EUT OPERATING MODE: Stand-by / Receive

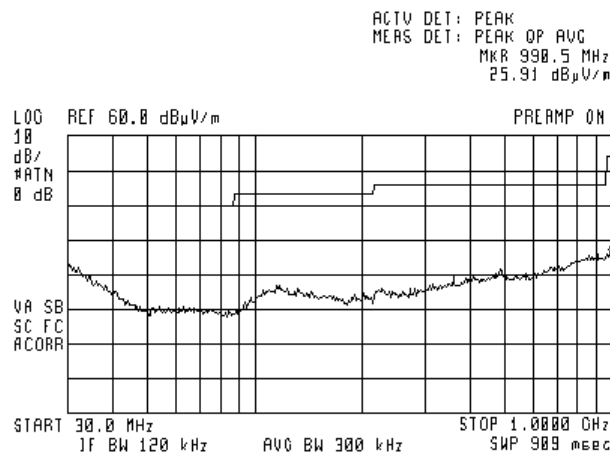



HERMON LABORATORIES

Test specification:		FCC Part 15, Section 109 / ICES-003 Class B, RSS-Gen Section 6.1, Radiated emission	
Test procedure:		ANSI C63.4, Sections 11.6 and 12.1.4 / RSS-Gen, Section 4.10 / CISPR 22	
Test mode:		Verdict: PASS	
Date(s):		6/9/2013	
Temperature: 25.6 °C	Air Pressure: 1005 hPa	Relative Humidity: 41 %	Power Supply: 120 VAC
Remarks:			

Plot 8.2.3 Radiated emission measurements above 1000 MHz, vertical antenna polarization

TEST SITE:	Semi anechoic chamber
LIMIT:	Class B
TEST DISTANCE:	3 m
EUT OPERATING MODE:	Stand-by / Receive

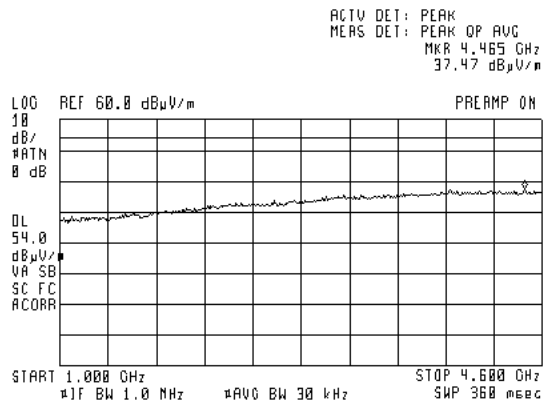
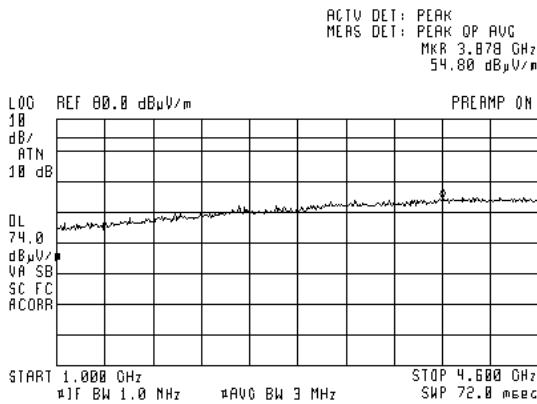

Plot 8.2.4 Radiated emission measurements above 1000 MHz, horizontal antenna polarization

TEST SITE:	Semi anechoic chamber
LIMIT:	Class B
TEST DISTANCE:	3 m
EUT OPERATING MODE:	Stand-by / Receive

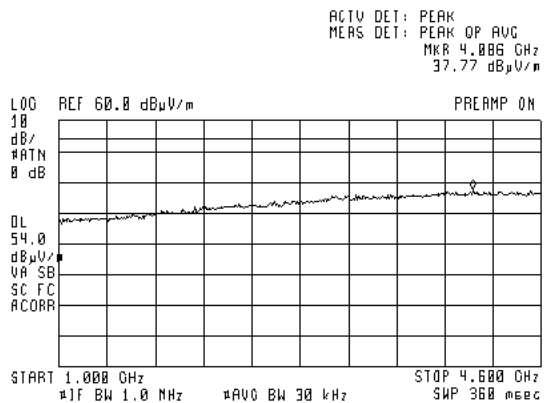
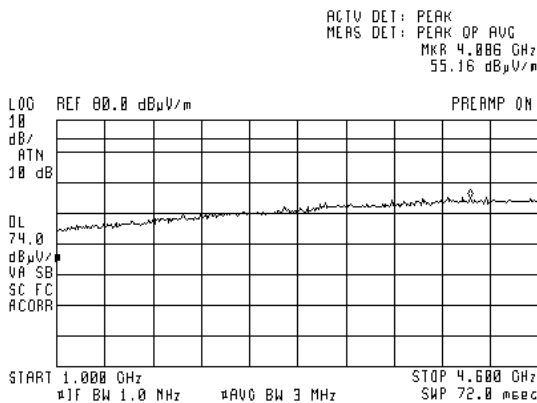

**9 APPENDIX A Test equipment and ancillaries used for tests**

HL No	Description	Manufacturer	Model	Ser. No.	Last Cal./ Check	Due Cal./ Check
0163	LISN FCC/VDE/50 Ohm/50 uH + 5 Ohm, MIL-STD-461E, CISPR 16-1	Electro-Metrics	ANS 25/2	1314	15-Jan-13	15-Jan-14
0446	Antenna, Loop, Active, 10 kHz - 30 MHz	EMCO	6502	2857	03-Jul-13	03-Jul-14
0521	EMI Receiver (Spectrum Analyzer) with RF filter section 9 kHz-6.5 GHz	Hewlett Packard	8546A	3617A 00319, 3448A002 53	22-Apr-13	22-Apr-14
0604	Antenna BiconiLog Log-Periodic/T Bow-TIE, 26 - 2000 MHz	EMCO	3141	9611-1011	04-Jun-13	04-Jun-14
0787	Transient Limiter 9 kHz-200 MHz	Hewlett Packard	11947A	3107A018 77	15-Oct-12	15-Oct-13
1425	EMI Receiver, 9 kHz - 2.9 GHz, System: HL1426, HL1427	Agilent Technologies	8542E	3710A002 22, 3705A002 04	26-Aug-12	26-Aug-13
1513	Cable RF, 8 m, BNC/BNC	Belden	M17/167 MIL-C-17	1513	02-Sep-12	02-Sep-13
1984	Antenna, Double-Ridged Waveguide Horn, 1-18 GHz, 300 W	EMC Test Systems	3115	9911-5964	07-Dec-12	07-Dec-13
2871	Microwave Cable Assembly, 18 GHz, 6.4 m, SMA - SMA	Huber-Suhner	198-8155-00	2871	04-Dec-12	04-Dec-13
3612	Cable RF, 17.5 m, N type-N type	Teldor	RG-214/U	NA	02-Dec-12	02-Dec-13
3818	PSA Series Spectrum Analyzer, 3 Hz- 44 GHz	Agilent Technologies	E4446A	MY482502 88	24-Apr-13	24-Apr-14
4160	Preamplifier, 0.1 to 18 GHz, Gain 25 dB, N-type(f) in, N-type(m) out.	Agilent Technologies	87405C	MY470105 94	08-Aug-12	08-Aug-13
4353	Low Loss Armored Test Cable, DC - 18 GHz, 6.2 m, N type-M/N type-M	MegaPhase	NC29- N1N1-244	12025101 003	06-Mar-13	06-Mar-14



10 APPENDIX B Measurement uncertainties

Expanded uncertainty at 95% confidence in Hermon Labs EMC measurements

Test description	Expanded uncertainty
Radiated emissions at 3 m measuring distance Horizontal polarization	Biconilog antenna: ± 5.3 dB Biconical antenna: ± 5.0 dB Log periodic antenna: ± 5.3 dB
Vertical polarization	Double ridged horn antenna: ± 5.3 dB Biconilog antenna: ± 6.0 dB Biconical antenna: ± 5.7 dB Log periodic antenna: ± 6.0 dB Double ridged horn antenna: ± 6.0 dB
Conducted emissions with LISN	9 kHz to 150 kHz: ± 3.9 dB 150 kHz to 30 MHz: ± 3.8 dB
Duty cycle, timing (Tx ON / OFF) and average factor measurements	± 1.0 %
Occupied bandwidth	± 8.0 %

Hermon Laboratories is accredited by A2LA for calibration according to present requirements of ISO/IEC 17025 and NCSL Z540-1. The accreditation is granted to perform calibration of parameters that are listed in the Scope of Hermon Laboratories Accreditation.

Hermon Laboratories calibrates its reference and transfer standards by calibration laboratories accredited to ISO/IEC 17025 by a mutually recognized Accreditation Body or by a recognized national metrology institute. All reference and transfer standards used in the calibration system are traceable to national or international standards.

In-house calibration of all test and measurement equipment is performed on a regular basis according to Hermon Laboratories calibration procedures, manufacturer calibration/verification procedures or procedures defined in the relevant standards. The Hermon Laboratories test and measurement equipment is calibrated within the tolerances specified by the manufacturers and/or by the relevant standards.

11 APPENDIX C Test laboratory description

Tests were performed at Hermon Laboratories Ltd., which is a fully independent, private, EMC, safety, environmental and telecommunication testing facility.

Hermon Laboratories is listed by the Federal Communications Commission (USA) for all parts of Code of Federal Regulations 47 (CFR 47), Registration Numbers 90624 for OATS and 90623 for the anechoic chamber; by Industry Canada for electromagnetic emissions (file numbers IC 2186A-1 for OATS, IC 2186A-2 for anechoic chamber, IC 2186A-3 for full-anechoic chamber for RE measurements above 1 GHz), certified by VCCI, Japan (the registration numbers are R-808 for OATS, R-1082 for anechoic chamber, G-27 for full-anechoic chamber for RE measurements above 1 GHz, C-845 for conducted emissions site, T-1606 for conducted emissions at telecommunication ports), has a status of a Telefication - Listed Testing Laboratory, Certificate No. L138/00. The laboratory is accredited by American Association for Laboratory Accreditation (USA) according to ISO/IEC 17025 for electromagnetic compatibility, product safety, telecommunications testing and environmental simulation (for exact scope please refer to Certificate No. 839.01). The FCC Designation Number is US1003.

Address: P.O. Box 23, Binyamina 30500, Israel.
Telephone: +972 4628 8001
Fax: +972 4628 8277
e-mail: mail@hermonlabs.com
website: www.hermonlabs.com

Person for contact: Mr. Alex Usoskin, CEO.

12 APPENDIX D Specification references

FCC 47CFR part 15: 2012	Radio Frequency Devices
ANSI C63.2: 1996	American National Standard for Instrumentation-Electromagnetic Noise and Field Strength, 10 kHz to 40 GHz-Specifications
ANSI C63.4: 2003	American National Standard for Methods of Measurement of Radio-Noise Emissions from Low-Voltage Electrical and Electronic Equipment in the Range of 9 kHz to 40 GHz
RSS-210 Issue 8: 2010	Low Power Licence- Exempt Radiocommunication Devices
RSS-Gen Issue 3: 2010	General Requirements and Information for the Certification of Radiocommunication Equipment
ICES-003 issue 5:2012	Information Technology Equipment (ITE) – Limits and methods of measurement



13 APPENDIX E Test equipment correction factors

Correction factor
Line impedance stabilization network
Model ANS-25/2, Electro-Metrics, HL 0163

Frequency, kHz	Correction factor, dB
10	4.9
15	2.86
20	1.83
25	1.25
30	0.91
35	0.69
40	0.53
50	0.35
60	0.25
70	0.18
80	0.14
90	0.11
100	0.09
125	0.06
150	0.04

The correction factor in dB is to be added to meter readings of an interference analyzer or a spectrum analyzer.



Antenna factor
Active loop antenna
Model 6502, S/N 2857, HL 0446

Frequency, MHz	Magnetic antenna factor, dB	Electric antenna factor, dB
0.009	-32.8	18.7
0.010	-33.8	17.7
0.020	-38.3	13.2
0.050	-41.1	10.4
0.075	-41.3	10.2
0.100	-41.6	9.9
0.150	-41.7	9.8
0.250	-41.6	9.9
0.500	-41.8	9.8
0.750	-41.9	9.7
1.000	-41.4	10.1
2.000	-41.5	10.0
3.000	-41.4	10.2
4.000	-41.4	10.1
5.000	-41.5	10.1
10.000	-41.9	9.6
15.000	-41.9	9.6
20.000	-42.2	9.3
25.000	-42.8	8.7
30.000	-44.0	7.5

Antenna factor in dB(1/m) is to be added to receiver meter reading in dB(μ V) to convert it into field intensity in dB(μ V/m).



Antenna factor
Biconilog antenna EMCO Model 3141
Ser.No.1011, HL 0604

Frequency, MHz	Antenna factor, dB(1/m)	Frequency, MHz	Antenna factor, dB(1/m)	Frequency, MHz	Antenna factor, dB(1/m)
26	7.8	580	20.6	1320	27.8
28	7.8	600	21.3	1340	28.3
30	7.8	620	21.5	1360	28.2
40	7.2	640	21.2	1380	27.9
60	7.1	660	21.4	1400	27.9
70	8.5	680	21.9	1420	27.9
80	9.4	700	22.2	1440	27.8
90	9.8	720	22.2	1460	27.8
100	9.7	740	22.1	1480	28.0
110	9.3	760	22.3	1500	28.5
120	8.8	780	22.6	1520	28.9
130	8.7	800	22.7	1540	29.6
140	9.2	820	22.9	1560	29.8
150	9.8	840	23.1	1580	29.6
160	10.2	860	23.4	1600	29.5
170	10.4	880	23.8	1620	29.3
180	10.4	900	24.1	1640	29.2
190	10.3	920	24.1	1660	29.4
200	10.6	940	24.0	1680	29.6
220	11.6	960	24.1	1700	29.8
240	12.4	980	24.5	1720	30.3
260	12.8	1000	24.9	1740	30.8
280	13.7	1020	25.0	1760	31.1
300	14.7	1040	25.2	1780	31.0
320	15.2	1060	25.4	1800	30.9
340	15.4	1080	25.6	1820	30.7
360	16.1	1100	25.7	1840	30.6
380	16.4	1120	26.0	1860	30.6
400	16.6	1140	26.4	1880	30.6
420	16.7	1160	27.0	1900	30.6
440	17.0	1180	27.0	1920	30.7
460	17.7	1200	26.7	1940	30.9
480	18.1	1220	26.5	1960	31.2
500	18.5	1240	26.5	1980	31.6
520	19.1	1260	26.5	2000	32.0
540	19.5	1280	26.6		
560	19.8	1300	27.0		

Antenna factor in dB(1/m) is to be added to receiver meter reading in dB(μV) to convert it into field strength in dB(μV/m).



Antenna factor
Double-ridged wave guide horn antenna
Model 3115, S/N 9911-5964, HL1984

Frequency, MHz	Antenna factor, dB(1/m)
1000.0	24.7
1500.0	25.7
2000.0	27.6
2500.0	28.9
3000.0	31.2
3500.0	32.0
4000.0	32.5
4500.0	32.7
5000.0	33.6
5500.0	35.1
6000.0	35.4
6500.0	34.9
7000.0	36.1
7500.0	37.8
8000.0	38.0
8500.0	38.1
9000.0	39.1
9500.0	38.3
10000.0	38.6
10500.0	38.2
11000.0	38.7
11500.0	39.5
12000.0	40.0
12500.0	40.4
13000.0	40.5
13500.0	41.1
14000.0	41.6
14500.0	41.7
15000.0	38.7
15500.0	38.2
16000.0	38.8
16500.0	40.5
17000.0	42.5
17500.0	45.9
18000.0	49.4

Antenna factor in dB(1/m) is to be added to receiver meter reading in dB(μ V) to convert it into field intensity in dB(μ V/m).



Cable loss
Cable coaxial, Huber-Suhner, 18 GHz, 6.4 m, SMA - SMA, model 198-8155-00,
HL 2871

Frequency, MHz	Cable loss, dB	Frequency, MHz	Cable loss, dB	Frequency, MHz	Cable loss, dB
10	0.12	5750	2.34	12000	3.55
30	0.14	6000	2.39	12250	3.61
100	0.27	6250	2.46	12500	3.67
250	0.45	6500	2.52	12750	3.74
500	0.63	6750	2.58	13000	3.79
750	0.76	7000	2.64	13250	3.82
1000	0.89	7250	2.68	13500	3.83
1250	1.01	7500	2.73	13750	3.83
1500	1.12	7750	2.78	14000	3.88
1750	1.23	8000	2.83	14250	3.93
2000	1.32	8250	2.88	14500	3.96
2250	1.41	8500	2.94	14750	4.01
2500	1.49	8750	2.97	15000	4.00
2750	1.58	9000	3.02	15250	4.01
3000	1.66	9250	3.07	15500	4.00
3250	1.73	9500	3.13	15750	4.13
3500	1.80	9750	3.18	16000	4.22
3750	1.87	10000	3.21	16250	4.29
4000	1.93	10250	3.26	16500	4.29
4250	2.01	10500	3.30	16750	4.32
4500	2.06	10750	3.36	17000	4.37
4750	2.12	11000	3.39	17250	4.45
5000	2.17	11250	3.44	17500	4.49
5250	2.24	11500	3.48	17750	4.53
5500	2.29	11750	3.52	18000	4.55



Cable loss
Cable coaxial, RG-214/U, N type-N type, 17 m
Teldor, HL 3612

Frequency, MHz	Cable loss, dB
0.1	0.05
0.5	0.07
1	0.10
3	0.22
5	0.29
10	0.39
30	0.68
50	0.90
100	1.27
150	1.58
200	1.80
250	2.12
300	2.36
350	2.60
400	2.82
450	2.99
500	3.23
550	3.40
600	3.56
650	3.71
700	3.90
750	4.04
800	4.23
850	4.39
900	4.55
950	4.65
1000	4.79



Cable loss
Low Loss Armored Test Cable, MegaPhase, 18 GHz, 6.2 m, N type-M/N type-M,
NC29-N1N1-244S/N 12025101 003,
HL 4353

Frequency, MHz	Cable loss, dB	Frequency, MHz	Cable loss, dB
50	0.20	9000	2.71
100	0.27	9500	2.81
300	0.47	10000	2.90
500	0.61	10500	2.97
1000	0.87	11000	3.06
1500	1.07	11500	3.13
2000	1.24	12000	3.20
2500	1.39	12500	3.26
3000	1.53	13000	3.34
3500	1.65	13500	3.39
4000	1.77	14000	3.47
4500	1.89	14500	3.54
5000	1.99	15000	3.62
5500	2.07	15500	3.69
6000	2.20	16000	3.76
6500	2.30	16500	3.83
7000	2.39	17000	3.86
7500	2.51	17500	3.94
8000	2.58	18000	4.02
8500	2.65		



14 APPENDIX F Abbreviations and acronyms

A	ampere
AC	alternating current
A/m	ampere per meter
AVRG	average (detector)
cm	centimeter
dB	decibel
dBm	decibel referred to one milliwatt
dB(μ V)	decibel referred to one microvolt
dB(μ V/m)	decibel referred to one microvolt per meter
dB(μ A)	decibel referred to one microampere
DC	direct current
EIRP	equivalent isotropically radiated power
ERP	effective radiated power
EUT	equipment under test
F	frequency
GHz	gigahertz
GND	ground
H	height
HL	Hermon laboratories
Hz	hertz
k	kilo
kHz	kilohertz
LO	local oscillator
m	meter
MHz	megahertz
min	minute
mm	millimeter
ms	millisecond
μ s	microsecond
NA	not applicable
OATS	open area test site
Ω	Ohm
PS	power supply
ppm	part per million (10^{-6})
QP	quasi-peak
RE	radiated emission
RF	radio frequency
rms	root mean square
Rx	receive
s	second
T	temperature
Tx	transmit
V	volt

END OF DOCUMENT