



PHOENIX
TESTLAB

Königswinkel 10

32825 Blomberg

Germany

Phone: +49 (0) 52 35 95 00-0

Fax: +49 (0) 52 35 95 00-10

Test Report

Report Number: F120962E3

Applicant:

audifon GmbH & Co. KG

Manufacturer:

audifon GmbH & Co. KG

Equipment under Test (EUT):



Hearing System

“eox IS TRT”, “via IS”, “eox IS”

Laboratory (CAB) accredited by
Deutsche Gesellschaft für Akkreditierung mbH
in compliance with DIN EN ISO/IEC 17025
under the Reg. No. DGA-PL-105/99-22,
FCC Test site registration number 90877 and
Industry Canada Test site registration IC3469A-1

REFERENCES

- [1] **ANSI C63.4-2009** American National Standard for Methods of Measuring of Radio-Noise Emissions from Low-Voltage Electrical and Electronic Equipment in the Range of 9 kHz to 40 GHz.
- [2] **FCC CFR 47 Part 15 (October 2011)** Radio Frequency Devices
- [3] **RSS-210 Issue 8 (December 2010)** Low-power Licence-exempt Radiocommunication Devices (All Frequency Bands): Category I Equipment
- [4] **RSS-Gen Issue 3 (December 2010)** General Requirements and Information for the Certification of Radiocommunication Equipment

| | | | |
|----------------------|----------------|--|---------------|
| Test engineer: | Raimund BLASK |  | 26 March 2012 |
| | Name | Signature | Date |
| Authorized reviewer: | Michael DINTER |  | 27 March 2012 |
| | Name | Signature | Date |

TEST RESULT

The requirements of the tests performed as shown in the overview (clause 4) were fulfilled by the equipment under test.
The complete test results are presented in the following.

RESERVATION

This test report is only valid in its original form.

Any reproduction of its contents in extracts without written permission of the accredited test laboratory PHOENIX TESTLAB GmbH is prohibited.

The test results herein refer only to the tested sample. PHOENIX TESTLAB GmbH is not responsible for any generalizations or conclusions drawn from these test results concerning further samples. Any modification of the tested samples is prohibited and leads to the invalidity of this test report. Each page necessarily contains the PHOENIX TESTLAB Logo and the TEST REPORT NUMBER.

| Contents: | Page |
|--|-------------|
| 1 IDENTIFICATION..... | 4 |
| 1.1 APPLICANT..... | 4 |
| 1.2 MANUFACTURER..... | 4 |
| 1.3 TEST LABORATORY..... | 4 |
| 1.4 EUT (EQUIPMENT UNDER TEST)..... | 5 |
| 1.5 TECHNICAL DATA OF EQUIPMENT..... | 5 |
| 1.6 DATES..... | 5 |
| 2 OPERATIONAL STATES..... | 6 |
| 3 ADDITIONAL INFORMATION (as declared by the applicant):..... | 6 |
| 4 OVERVIEW..... | 7 |
| 5 METHODS OF MEASUREMENT..... | 8 |
| 5.1 RADIATED EMISSIONS..... | 8 |
| 5.2 RADIATED EMISSIONS..... | 15 |
| 5.2.1 TEST RESULTS (RADIATED EMISSIONS)..... | 15 |
| 5.2.1.1 PRELIMINARY AND FINAL RADIATED EMISSION MEASUREMENT..... | 15 |
| 5.2.1.2 PRELIMINARY MEASUREMENT (30 MHz to 1 GHz)..... | 17 |
| 6 TEST EQUIPMENT AND ANCILLARIES USED FOR TESTS..... | 18 |
| 7 REPORT HISTORY..... | 18 |
| 8 LIST OF ANNEXES..... | 19 |

1 IDENTIFICATION

1.1 APPLICANT

| | |
|----------------------------|---|
| Name: | audifon GmbH & Co. KG |
| Address: | Werner-von-Siemens-Straße 2 99625 Köllda |
| Country: | Germany |
| Name for contact purposes: | Mr. Stephan Teders |
| Tel: | +49-(0)-2202-92638-14 |
| Fax: | +49-(0)-2202-92638-29 |
| e-mail address: | stephan.teders@audifon.com |

1.2 MANUFACTURER

| | |
|----------------------------|---|
| Name: | audifon GmbH & Co. KG |
| Address: | Werner-von-Siemens-Straße 2 99625 Köllda |
| Country: | Germany |
| Name for contact purposes: | Mr. Stephan Teders |
| Tel: | +49-(0)-2202-92638-14 |
| Fax: | +49-(0)-2202-92638-29 |
| e-mail address: | stephan.teders@audifon.com |

1.3 TEST LABORATORY

The tests were carried out at: **PHOENIX TESTLAB GmbH**
Königswinkel 10
32825 Blomberg
Germany

accredited by DGA Deutsche Gesellschaft für Akkreditierung mbH in compliance with
DIN EN ISO/IEC 17025 under Reg. No. DGA-PL-105/99-22, FCC Test site registration number
90877 and Industry Canada Test site registration IC3469A-1.

1.4 EUT (EQUIPMENT UNDER TEST)

| | |
|---------------------|---|
| Test object: * | Hearing System |
| Type: * | “eox IS TRT”; “via IS”, “eox IS” |
| Antenna type: * | Integral H-Field-Antenna (6mm x 2mm coil with 22 turns) |
| Hardware version: * | - |
| Software version: * | - |

1.5 TECHNICAL DATA OF EQUIPMENT

| | | | | | | |
|-------------------------------------|---|-------|--------------------|-------|--------------------|-------|
| Duty cycle class: * | Up to 100% | | | | | |
| Rated transmitter field strength: * | ≤ -13 dBμA/m @ 1 m distance | | | | | |
| Channel spacing: * | - | | | | | |
| ITU classification: * | 545KF1D | | | | | |
| Alignment range: * | 10.525 MHz | | | | | |
| Switching range: * | 10.525 MHz | | | | | |
| Modulation: * | FSK | | | | | |
| Bit rate of transmitter: * | 298 kBit/s | | | | | |
| Supply Voltage: * (TX) | U _{Nom} = | 1.4 V | U _{Min} = | 0.9 V | U _{Max} = | 1.7 V |
| Power Supply: * (TX) | 1.4 V ZincAir-Battery | | | | | |
| Temperature range: * | -20°C to 55°C (tested range), 0°C to 35°C (manufacturers declaration) | | | | | |

*: Declared by the applicant.

The following external I/O cables were used:

| Identification | Connector | | Length* |
|----------------|-----------|-----------|---------|
| | EUT | Ancillary | |
| - | - | - | - |

*: Length during the test.

1.6 DATES

| | |
|---------------------------------|---------------|
| Date of receipt of test sample: | 16 March 2012 |
| Start of test: | 19 March 2012 |
| End of test: | 23 March 2012 |

2 OPERATIONAL STATES

The tests was carried out with unmodified test samples. The EUT was powered with the internal 1.4V ZincAir-Batteries.

The EUT "via IS" was used for the Test because a continuous audio link is available.

The physical boundaries are shown below:

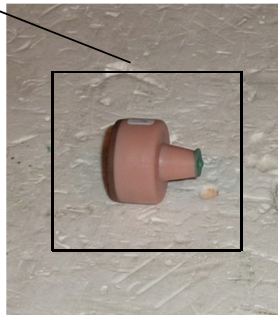

3 ADDITIONAL INFORMATION (as declared by the applicant):

The different EUT`s "eox IS TRT", "via IS" and "eox IS" are based on the same Hardware.

Only additional Software-Features are available for different user modes. If not otherwise stated, the EUT "via IS" was tested as worst case (continuous audio transmission) operation mode.

4 OVERVIEW

| Application | Frequency range [MHz] | FCC 47 CFR Part 15 section [2] | RSS 210 [3] or RSS-Gen [4] | Status | Refer page |
|------------------------------------|-----------------------|--------------------------------|----------------------------|-----------------|------------|
| Radiated emissions | 0.009 - 1,000 | 15.205 (a) 15.209 (a) | 2.6 [3] | Passed | 15 et seq. |
| Conducted emissions on supply line | 0.15 - 30 | 15.207 (a) | 7.2.2 [4] | Not applicable* | - |
| 99 % bandwidth | 10.525 MHz | - | 4.6.1 [4] | Passed | Annex D |

* EUT is battery-powered, no lines available.

5 METHODS OF MEASUREMENT

5.1 RADIATED EMISSIONS

The radiated emission measurement is subdivided into five stages.

- A preliminary measurement carried out in a fully anechoic chamber with a fixed antenna height in the frequency range 9 kHz to 1 GHz.
- A final measurement carried out on an outdoor test site without reflecting ground plane and a fixed antenna height in the frequency range 9 kHz to 30 MHz.
- A final measurement carried out on an open area test site with reflecting ground plane and various antenna heights in the frequency range 30 MHz to 1 GHz.
- A preliminary measurement carried out in a fully anechoic chamber with a variable antenna distance and height in the frequency range 1 GHz to 25 / 40 GHz.
- A final measurement carried out in a fully anechoic chamber with a fixed antenna height in the frequency range 1 GHz to 25 / 40 GHz.

Preliminary measurement (9 kHz to 30 MHz):

In the first stage a preliminary measurement will be performed in a shielded room with a measuring distance of 3 meters. Tabletop devices will set up on a non-conducting support with a size of 1 m by 1.5 m and a height of 80 cm. Floor-standing devices will be placed directly on the turntable/ground plane. The set up of the Equipment under test will be in accordance to ANSI C63.4-2009 [1].

The frequency range 9 kHz to 30 MHz will be monitored with a spectrum analyser while the system and its cables will be manipulated to find out the configuration with the maximum emission levels if applicable. The EMI Receiver will be set to MAX Hold mode. The EUT and the measuring antenna will be rotated around their vertical axis to found the maximum emissions.

The resolution bandwidth of the spectrum analyser will be set to the following values:

| Frequency range | Resolution bandwidth |
|-------------------|----------------------|
| 9 kHz to 150 kHz | 200 Hz |
| 150 kHz to 30 MHz | 10 kHz |

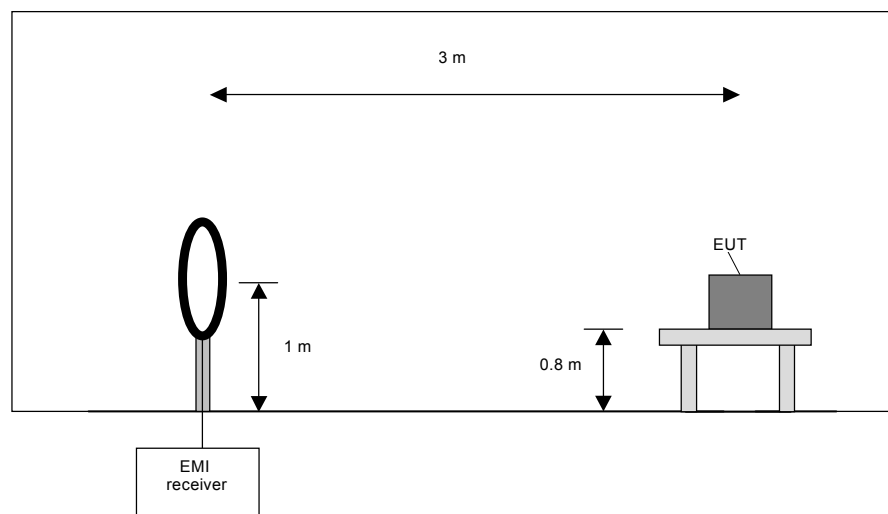

Preliminary measurement procedure:

Prescans were performed in the frequency range 9 kHz to 150 kHz and 150 kHz to 30 MHz.

The following procedure will be used:

- 1) Monitor the frequency range at horizontal polarisation and a EUT azimuth of 0 °.
- 2) Manipulate the system cables within the range to produce the maximum level of emission.
- 3) Rotate the EUT by 360 ° to maximize the detected signals.
- 4) Make a hardcopy of the spectrum.
- 5) Measure the frequencies of highest detected emission with a lower span and resolution bandwidth to increase the accuracy and note the frequency value.
- 6) Repeat steps 1) to 5) with the other orthogonal axes of the EUT (because of EUT is a module and might be used in a handheld equipment application).
- 7) Rotate the measuring antenna and repeat steps 1) to 5).

Final measurement (9 kHz to 30 MHz):

In the second stage a final measurement will be performed on an open area test site with no conducting ground plane in measuring distances of 3 m, 10 m and 30 m. In the case where larger measuring distances is required the results will be extrapolated based on the values measured on the closer distances according to Section 15.31 (f) (2) [2]. The final measurement will be performed with a EMI Receiver set to Quasi Peak detector except for the frequency bands 9 kHz to 90 kHz and 110 kHz to 490 kHz where an average detector will be used according Section 15.209 (d) [2].

On the during the preliminary measurement detected frequencies the final measurement will be performed while rotating the EUT and the measuring antenna in the range of 0 ° to 360 ° around their vertical axis until the maximum value is found.

The resolution bandwidth of the EMI Receiver will be set to the following values:

| Frequency range | Resolution bandwidth |
|-------------------|----------------------|
| 9 kHz to 150 kHz | 200 Hz |
| 150 kHz to 30 MHz | 9 kHz |

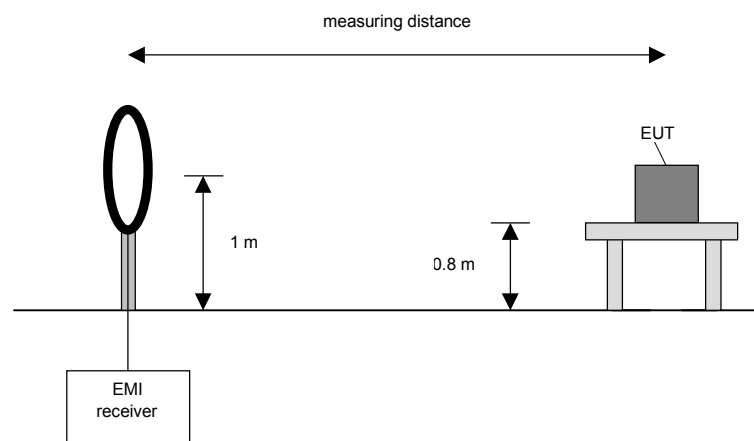

Final measurement procedure:

The following procedure will be used:

- 1) Monitor the frequency range with the measuring antenna at vertical orientation parallel to the EUT at an azimuth of 0 °.
- 2) Rotate the EUT by 360 ° to maximize the detected signals and note the azimuth and orientation.
- 3) Rotate the measuring antenna to find the maximum and note the value.
- 4) Rotate the measuring antenna and repeat steps 1) to 3) until the maximum value is found.
- 5) Repeat steps 1) to 4) with the other orthogonal axes of the EUT (because of EUT is a module and might be used in a handheld equipment application).

Preliminary measurement (30 MHz to 1 GHz)

In the first stage a preliminary measurement will be performed in a fully anechoic chamber with a measuring distance of 3 meter. Tabletop devices will set up on a non-conducting support with a size of 1 m by 1.5 m and a height of 80 cm. Floor-standing devices will be placed directly on the turntable/ground plane. The set up of the Equipment under test will be in accordance to ANSI C63.4-2009 [1].

The frequency range 30 MHz to 1 GHz will be measured with an EMI Receiver set to MAX Hold mode and a resolution bandwidth of 100 kHz. The measurement will be performed in horizontal and vertical polarisation of the measuring antenna and while rotating the EUT in its vertical axis in the range of 0 ° to 360 °.

The resolution bandwidth of the EMI Receiver will be set to the following values:

| Frequency range | Resolution bandwidth |
|-------------------|----------------------|
| 30 MHz to 230 MHz | 100 kHz |
| 230 MHz to 1 GHz | 100 kHz |

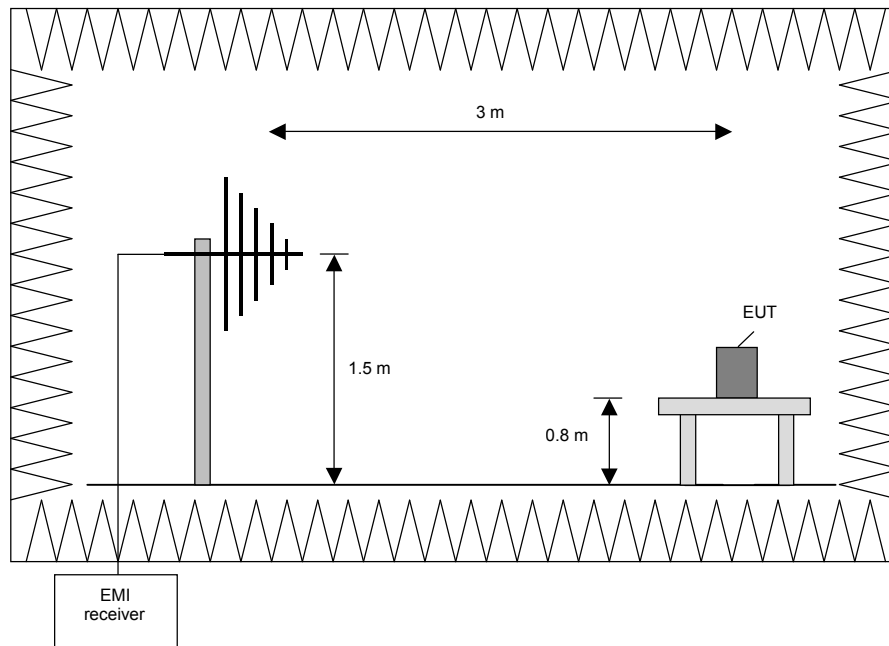

Procedure preliminary measurement:

Prescans were performed in the frequency range 30 MHz to 230 MHz and 230 MHz to 1 GHz.

The following procedure will be used:

1. Monitor the frequency range at horizontal polarisation and a EUT azimuth of 0 °.
2. Manipulate the system cables within the range to produce the maximum level of emission.
3. Rotate the EUT by 360 ° to maximize the detected signals.
4. Make a hardcopy of the spectrum.
5. Measure the frequency of the detected emissions with a lower span and resolution bandwidth to increase the accuracy and note the frequency value.
6. Repeat 1) to 4) with the other orthogonal axes of the EUT (because of EUT is a module and might be used in a handheld equipment application).
7. Repeat 1) to 5) with the vertical polarisation of the measuring antenna.

Final measurement (30 MHz to 1 GHz)

A final measurement on an open area test site will be performed on selected frequencies found in the preliminary measurement. During this test the EUT will be rotated in the range of 0 ° to 360 °, the measuring antenna will be set to horizontal and vertical polarisation and raised and lowered in the range from 1 m to 4 m to find the maximum level of emissions.

The resolution bandwidth of the EMI Receiver will be set to the following values:

| Frequency range | Resolution bandwidth |
|-----------------|----------------------|
| 30 MHz to 1 GHz | 120 kHz |

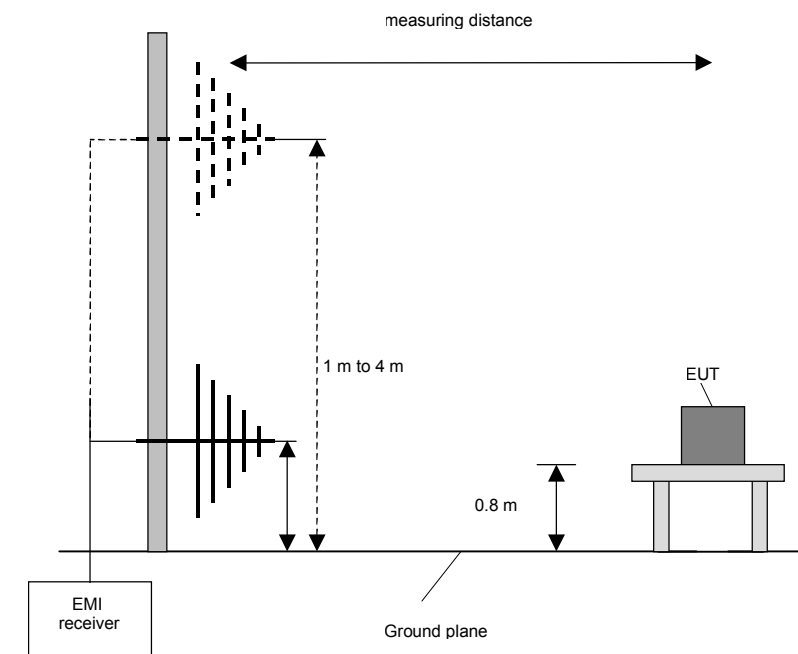

Procedure final measurement:

The following procedure will be used:

- 1) Measure on the selected frequencies at an antenna height of 1 m and a EUT azimuth of 23 °.
- 2) Move the antenna from 1 m to 4 m and note the maximum value at each frequency.
- 3) Rotate the EUT by 45 ° and repeat 2) until an azimuth of 337 ° is reached.
- 4) Repeat 1) to 3) for the other orthogonal antenna polarization.
- 5) Move the antenna and the turntable to the position where the maximum value is detected.
- 6) Measure while moving the antenna slowly +/- 1 m.
- 7) Set the antenna to the position where the maximum value is found.
- 8) Measure while moving the turntable +/- 45 °.
- 9) Set the turntable to the azimuth where the maximum value is found.
- 10) Measure with Final detector (QP and AV) and note the value.
- 11) Repeat 5) to 10) for each frequency.
- 12) Repeat 1) to 11) for each orthogonal axes of the EUT (because of EUT is a module and might be used in a handheld equipment application).

Preliminary and final measurement (1 GHz to 40 GHz)

This measurement will be performed in a fully anechoic chamber. Tabletop devices will set up on a non-conducting support with a size of 1 m by 1.5 m and a height of 80 cm. Floor-standing devices will be placed directly on the turntable/ground plane. The set up of the Equipment under test will be in accordance to ANSI C63.4-2009 [1].

Preliminary measurement (1 GHz to 40 GHz)

The frequency range will be divided into different sub ranges depending of the frequency range of the used horn antenna. The spectrum analyser set to MAX Hold mode and a resolution bandwidth of 100 kHz. The measurement will be performed in horizontal and vertical polarisation of the measuring antenna, the antenna close to the EUT and while moving the antenna over all sides of the EUT. With the spectrum analyser in CLEAR / WRITE mode the cone of the emission should be found and than the measuring distance will be set to 3 m with the receiving antenna moving in this cone of emission. At this position the final measurement will be carried out.

The resolution bandwidth of the EMI Receiver will be set to the following values:

| Frequency range | Resolution bandwidth |
|-------------------------|----------------------|
| 1 GHz to 4 GHz | 100 kHz |
| 4 GHz to 12 GHz | 100 kHz |
| 12 GHz to 18 GHz | 100 kHz |
| 18 GHz to 25 / 26.5 GHz | 100 kHz |
| 26.5 GHz to 40 GHz | 100 kHz |

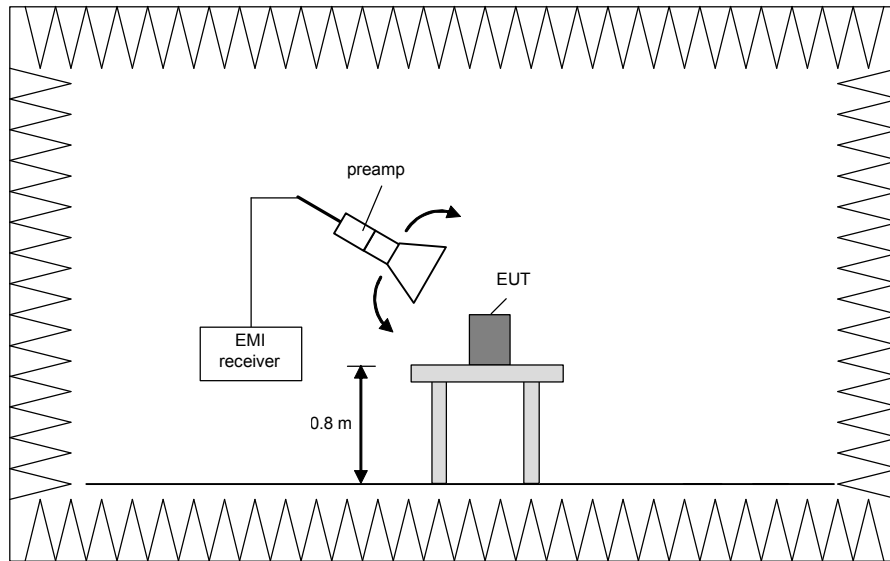

Final measurement (1 GHz to 40 GHz)

The frequency range will be divided into different sub ranges depending of the frequency range of the used horn antenna. The EMI Receiver set to peak and average mode and a resolution bandwidth of 1 MHz. The measurement will be performed in horizontal and vertical polarisation of the measuring antenna and while rotating the EUT in its vertical axis in the range of 0 ° to 360 ° in order to have the antenna inside the cone of radiation.

The resolution bandwidth of the EMI Receiver will be set to the following values:

| Frequency range | Resolution bandwidth |
|-------------------------|----------------------|
| 1 GHz to 4 GHz | 1 MHz |
| 4 GHz to 12 GHz | 1 MHz |
| 12 GHz to 18 GHz | 1 MHz |
| 18 GHz to 25 / 26.5 GHz | 1 MHz |
| 26.5 GHz to 40 GHz | 1 MHz |

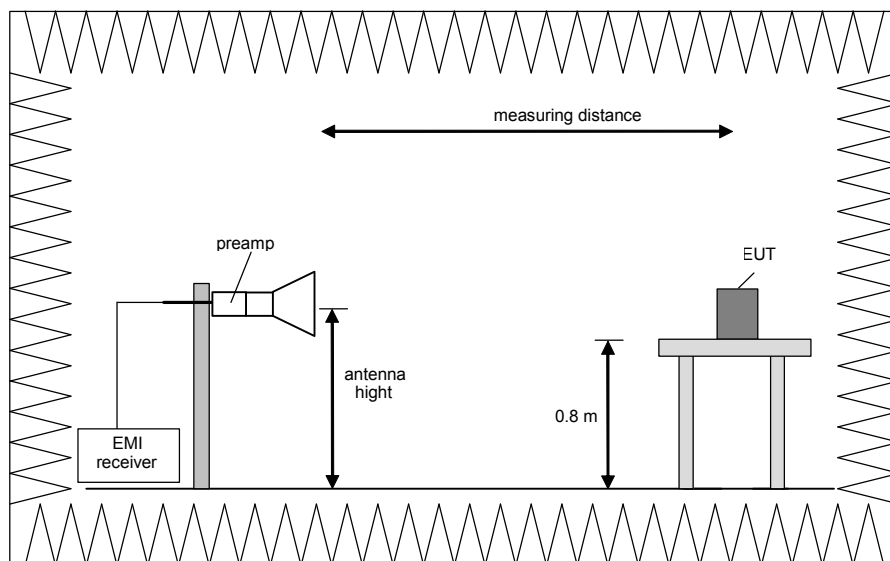

Procedure of measurement:

The measurements were performed in the frequency ranges 1 GHz to 4 GHz, 4 GHz to 12 GHz, 12 GHz to 18 GHz, 18 GHz to 25 /26.5 GHz and 26.5 GHz to 40 GHz.

The following procedure will be used:

- 1) Monitor the frequency range at horizontal polarisation and move the antenna over all sides of the EUT (if necessary move the EUT to another orthogonal axis).
- 2) Change the antenna polarisation and repeat 1) with vertical polarisation.
- 3) Make a hardcopy of the spectrum.
- 4) Measure the frequency of the detected emissions with a lower span and resolution bandwidth to increase the accuracy and note the frequency value.
- 5) Change the analyser mode to Clear / Write and found the cone of emission.
- 6) Rotate and move the EUT, so that the measuring distance can be enlarged to 3 m and the antenna will be still inside the cone of emission.
- 7) Measure the level of the detected frequency with the correct resolution bandwidth, with the antenna polarisation and azimuth and the peak and average detector, which causes the maximum emission.
- 8) Repeat steps 1) to 7) for the next antenna spot if the EUT is larger than the antenna beamwidth.

Step 1) to 6) are defined as preliminary measurement.

5.2 RADIATED EMISSIONS

5.2.1 TEST RESULTS (RADIATED EMISSIONS)

5.2.1.1 PRELIMINARY AND FINAL RADIATED EMISSION MEASUREMENT (9 kHz to 30 MHz)

| | | | |
|---------------------|-------|-------------------|------|
| Ambient temperature | 20 °C | Relative humidity | 35 % |
|---------------------|-------|-------------------|------|

Position of EUT: The EUT was set-up on a non-conducting table of a height of 0.8 m. The distance between EUT and antenna was 3 m.

Cable guide: The cable of the EUT is running vertically to the false floor. For detail information of test set-up and the cable guide refer to the pictures in annex A of this test report.

Test record: All results are shown in the following.

Supply voltage: During all measurements the EUT`s were supplied with 1.4 V.

120962FCC1.wmf: Spurious emissions from 9 kHz to 150 kHz:

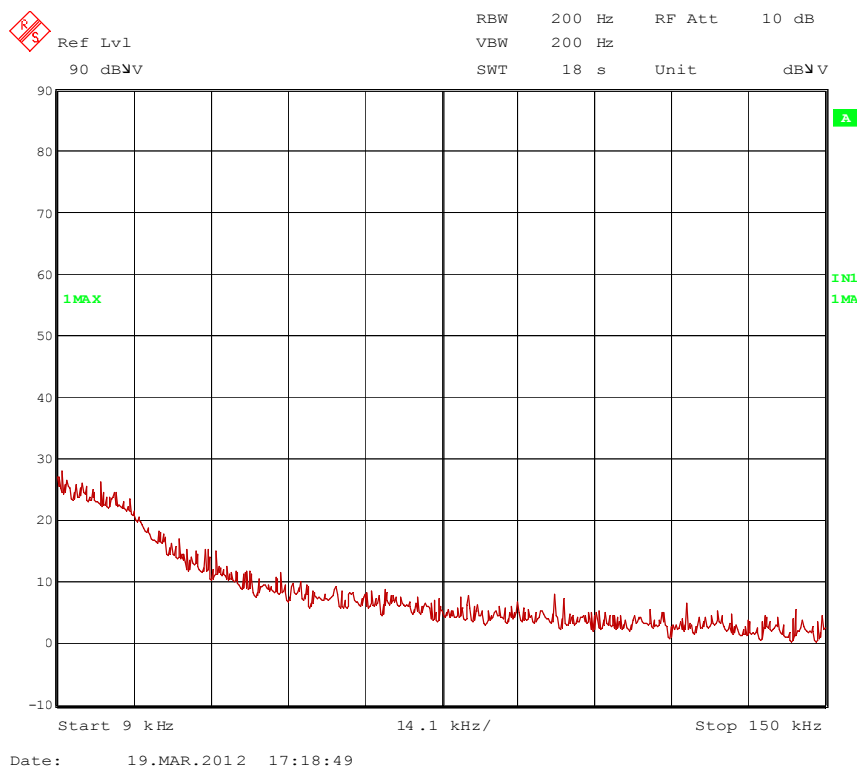

120962FCC2.wmf: Spurious emissions from 150 kHz to 30 MHz:

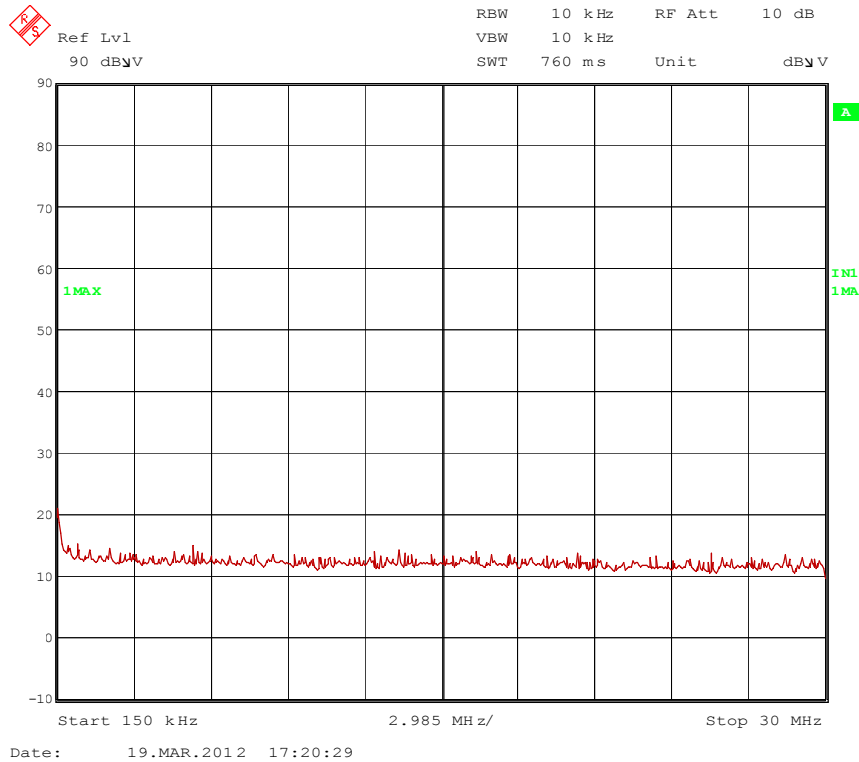

| Frequency (MHz) | Field strength (microvolts/meter) | Measurement distance (meters) |
|-----------------|-----------------------------------|-------------------------------|
| 0.009–0.490 | 2400/F(kHz) | 300 |
| 0.490–1.705 | 24000/F(kHz) | 30 |
| 1.705–30.0 | 30 | 30 |
| 30–88 | 100** | 3 |
| 88–216 | 150** | 3 |
| 216–960 | 200** | 3 |
| Above 960 | 500 | 3 |

Only the wanted frequency at 10.525 MHz was detected above the noise floor of the system during the preliminary radiated emission test.

Test results: The test results were calculated with the following formula:
Result [dBµV/m] = reading [dBµV] + antenna factor [dB/m]

| Results with measuring distance of 1 m | | | | | | |
|--|---------------|----------------------------|-------------------|----------|---------------|-----------------------------------|
| Frequency | Result dBµV/m | Limit* ¹ dBµV/m | Margin dB | Detector | Readings dBµV | Antenna factor* ² dB/m |
| 10.525 MHz | 35.5 | 89.5 | 54.0 | QP | 15.5 | 20.0 |
| Measurement uncertainty | | | +2.2 dB / -3.6 dB | | | |

*¹: Limit corrected with 40 dB / decade

*²: Cable loss included

Remark: At distances more than 1 m the wanted signal was below the noise of the measuring system.

| |
|-----------------------------------|
| TEST EQUIPMENT USED FOR THE TEST: |
| 1, 2, 4 – 7, 9 |

5.2.1.2 PRELIMINARY MEASUREMENT (30 MHz to 1 GHz)

| | | | |
|---------------------|-------|-------------------|------|
| Ambient temperature | 20 °C | Relative humidity | 40 % |
|---------------------|-------|-------------------|------|

Position of EUT: The EUT was set-up on a non-conducting table of a height of 0.8 m. The distance between EUT and antenna was 3 m.

Cable guide: The cables of the EUT were fixed on the non-conducting table. For further information of the cable guide refer to the pictures in annex A of this test report.

Test record: All results are shown in the following.

Supply voltage: During all measurements the EUT was supplied with 1.4 V.

120962FCC3.wmf: Spurious emissions from 30 MHz to 1 GHz:

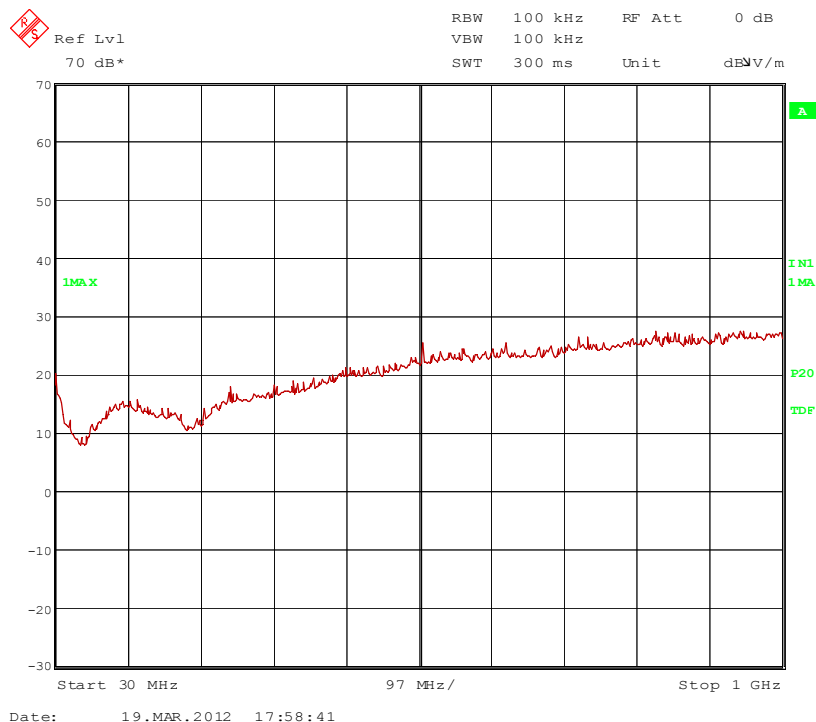

| Frequency (MHz) | Field strength (microvolts/meter) | Measurement distance (meters) |
|-----------------|-----------------------------------|-------------------------------|
| 0.009–0.490 | 2400/F(kHz) | 300 |
| 0.490–1.705 | 24000/F(kHz) | 30 |
| 1.705–30.0 | 30 | 30 |
| 30–88 | 100** | 3 |
| 88–216 | 150** | 3 |
| 216–960 | 200** | 3 |
| Above 960 | 500 | 3 |

The following frequencies were found inside the restricted bands during the preliminary radiated emission test:

-

The following frequencies were found outside the restricted bands during the preliminary radiated emission test:

-

Therefore no frequencies were measured in a final measurement on an open area test-site.

| |
|-----------------------------------|
| TEST EQUIPMENT USED FOR THE TEST: |
| 2, 4 - 8 |

6 TEST EQUIPMENT AND ANCILLARIES USED FOR TESTS

| No. | Test equipment | Type | Manufacturer | Serial No. | PM. No. | Cal. Date | Cal. due |
|-----|----------------------------|-----------|--------------------|-------------------|---------|-----------------------------------|------------|
| 1 | Open area test site | - | Phoenix Test-Lab | - | 480085 | Weekly verification (system cal.) | |
| 2 | Fully anechoic chamber M20 | - | Albatross Projects | B83107-E2439-T232 | 480303 | Weekly verification (system cal.) | |
| 3 | Spectrum analyser | FSU | Rohde & Schwarz | 200125 | 480956 | 02/15/2012 | 02/15/2014 |
| 4 | Measuring receiver | ESI 40 | Rohde & Schwarz | 100064 | 480355 | 02/13/2012 | 02/13/2014 |
| 5 | Controller | MCU | Maturo | MCU/043/971107 | 480832 | - | - |
| 6 | Turntable | DS420HE | Deisel | 420/620/80 | 480315 | - | - |
| 7 | Antenna support | AS615P | Deisel | 615/310 | 480187 | - | - |
| 8 | Antenna | CBL6112 B | Chase | 2688 | 480328 | 04/21/2011 | 04/21/2014 |
| 9 | Loop antenna | HFH2-Z2 | Rohde & Schwarz | 832609/014 | 480059 | 02/26/2012 | 02/26/2014 |

7 REPORT HISTORY

| Report Number | Date | Comment |
|---------------|---------------|------------------|
| F120962E3 | 26 March 2012 | Document created |
| - | - | - |
| - | - | - |

8 LIST OF ANNEXES

| | | |
|---------|---|---------|
| ANNEX A | TEST SETUP PHOTOS | 3 pages |
| | 120962emi1.jpg: Test set-up radiated emission (E-Field) 120962emi2.jpg: Test set-up preliminary radiated emission (H-Field) 120962emi3.jpg: Test set-up final radiated emission (H-Field) | |
| ANNEX B | EXTERNAL PHOTOGRAPHS | 1 page |
| ANNEX C | INTERNAL PHOTOGRAPHS | 2 pages |
| ANNEX D | ADDITIONAL RESULTS FOR INDUSTRY CANADA | 2 Pages |