

FCC Test Report

APPLICANT : CT Asia
EQUIPMENT : Mobile phone
BRAND NAME : BLU
MODEL NAME : Dash 4.5
MARKETING NAME : Dash 4.5
FCC ID : YHLBLUDASH45
STANDARD : FCC 47 CFR FCC Part 15 Subpart B
CLASSIFICATION : Certification

The product was received on Apr. 25, 2013 and completely tested on Jun. 25, 2013. We, SPORTON INTERNATIONAL (SHENZHEN) INC., would like to declare that the tested sample has been evaluated in accordance with the procedures given in ANSI C63.4-2003 and shown the compliance with the applicable technical standards.

The test results in this report apply exclusively to the tested model / sample. Without written approval of SPORTON INTERNATIONAL (SHENZHEN) INC., the test report shall not be reproduced except in full.

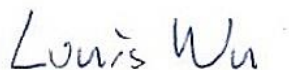

Reviewed by: Louis Wu / Manager

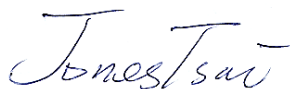

Approved by: Jones Tsai / Manager

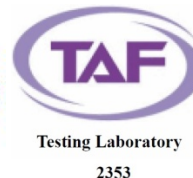

SPORTON INTERNATIONAL (SHENZHEN) INC.

No. 3 Building, the third floor of south, Shahe River west, Fengzeyuan warehouse, Nanshan District, Shenzhen, Guangdong, P.R.C.



TABLE OF CONTENTS

REVISION HISTORY..... 3

SUMMARY OF TEST RESULT 4

1. GENERAL DESCRIPTION 5

 1.1. Applicant..... 5

 1.2. Manufacturer 5

 1.3. Feature of Equipment Under Test..... 5

 1.4. Product Specification of Equipment Under Test 6

 1.5. Modification of EUT..... 7

 1.6. Test Site 7

 1.7. Applied Standards 7

2. TEST CONFIGURATION OF EQUIPMENT UNDER TEST 8

 2.1. Test Mode 8

 2.2. Connection Diagram of Test System 10

 2.3. Support Unit used in test configuration and system..... 11

 2.4. EUT Operation Test Setup 12

3. TEST RESULT..... 13

 3.1. Test of AC Conducted Emission Measurement 13

 3.2. Test of Radiated Emission Measurement 19

4. LIST OF MEASURING EQUIPMENT 23

5. UNCERTAINTY OF EVALUATION 24

APPENDIX A. PHOTOGRAPHS OF EUT

APPENDIX B. SETUP PHOTOGRAPHS



REVISION HISTORY

REPORT NO.	VERSION	DESCRIPTION	ISSUED DATE
FC342511	Rev. 01	Initial issue of report	Jul. 1, 2013



SUMMARY OF TEST RESULT

Report Section	FCC Rule	Description	Limit	Result	Remark
3.1	15.107	AC Conducted Emission	< 15.107 limits	PASS	Under limit 7.65 dB at 0.380 MHz
3.2	15.109	Radiated Emission	< 15.109 limits	PASS	Under limit 2.56 dB at 240.060 MHz

1. General Description

1.1. Applicant

CT Asia

Unit 01, 15/F, Seaview Centre, 139-141 Hoi bun road, Kwun Tong, Kowloon, Hongkong

1.2. Manufacturer

Ragentek Technology Group

Building D10-D11, No. 58-60, Lane 3188, Xiupu Road, PuDong District, Shanghai, PRC

1.3. Feature of Equipment Under Test

Product Feature	
Equipment	Mobile phone
Brand Name	BLU
Model Name	Dash 4.5
Marketing Name	Dash 4.5
FCC ID	YHLBLUDASH45
EUT supports Radios application	GSM/GPRS/WCDMA/HSPA/HSPA+/ WLAN 11bgn/Bluetooth/Bluetooth v4.0 - LE
HW Version	V1.2
SW Version	BLU-D310-V05-GENERIC
EUT Stage	Identical Prototype

Remark: The above EUT's information was declared by manufacturer. Please refer to the specifications or user's manual for more detailed description.

1.4. Product Specification of Equipment Under Test

Product Specification subjective to this standard	
Tx Frequency Range	GSM850: 824.2 MHz ~ 848.8 MHz GSM1900: 1850.2 MHz ~ 1909.8MHz WCDMA Band V: 826.4 MHz ~ 846.6 MHz WCDMA Band II: 1852.4 MHz ~ 1907.6 MHz 802.11b/g/n: 2412 MHz ~ 2462 MHz Bluetooth: 2402 MHz ~ 2480 MHz
Rx Frequency Range	GSM850: 869.2 MHz ~ 893.8 MHz GSM1900: 1930.2 MHz ~ 1989.8 MHz WCDMA Band V: 871.4 MHz ~ 891.6 MHz WCDMA Band II: 1932.4 MHz ~ 1987.6 MHz 802.11b/g/n: 2412 MHz ~ 2462 MHz Bluetooth: 2402 MHz ~ 2480 MHz GPS: 1.57542 GHz FM: 88 MHz ~ 108 MHz
Antenna Type	WWAN: PIFA Antenna WLAN: Monopole Antenna Bluetooth: Monopole Antenna
Type of Modulation	GSM: GMSK GPRS: GMSK WCDMA: QPSK (Uplink) HSDPA: QPSK (Uplink) HSUPA: QPSK (Uplink) HSPA+: 16QAM(Uplink) 802.11b : DSSS (DBPSK / DQPSK / CCK) 802.11g/n : OFDM (BPSK / QPSK / 16QAM / 64QAM) Bluetooth BR (1Mbps) : GFSK Bluetooth EDR (2Mbps) : $\pi/4$ -DQPSK Bluetooth EDR (3Mbps) : 8-DPSK Bluetooth 3.0 EDR : GFSK, $\pi/4$ -DQPSK, 8-DPSK Bluetooth v4.0 - LE: GFSK GPS : BPSK FM

1.5. Modification of EUT

No modifications are made to the EUT during all test items.

1.6. Test Site

Test Site	SPORTON INTERNATIONAL (SHENZHEN) INC.		
Test Site Location	No. 3 Building, the third floor of south, Shahe River west, Fengzeyuan warehouse, Nanshan District, Shenzhen, Guangdong, P.R.C. TEL: +86-755- 3320-2398		
Test Site No.	Sporton Site No.		FCC/IC Registration No.
	CO01-SZ	03CH01-SZ	831040/4086F-1

1.7. Applied Standards

According to the specifications of the manufacturer, the EUT must comply with the requirements of the following standards:

- FCC 47 CFR FCC Part 15 Subpart B
- ANSI C63.4-2003

Remark: All test items were verified and recorded according to the standards and without any deviation during the test.

2. Test Configuration of Equipment Under Test

2.1. Test Mode

The EUT has been associated with peripherals pursuant to ANSI C63.4-2003 and configuration operated in a manner tended to maximize its emission characteristics in a typical application.

Frequency range investigated: conduction (150 KHz to 30 MHz), radiation (30MHz to the 5th harmonic of the highest fundamental frequency or to 40 GHz, whichever is lower).

The following tables are showing the test modes as the worst cases and recorded in this report.

Item	EUT Configuration	Test Condition		
		EMI AC	EMI RE<1G	EMI RE≥1G
1.	Charging Mode (EUT with adapter)	☒	☒	Note 1
2.	Data application transferred mode (EUT with PC)	☒	☒	☒

Abbreviations:

- EMI AC: AC conducted emissions
- EMI RE ≥ 1G: EUT radiated emissions ≥ 1GHz
- EMI RE < 1G: EUT radiated emissions < 1GHz

Note 1: Testing for this mode is not required or not the worst case.

Remark: For signal above 1GHz, the worst case was test item 2.

Test Items	EUT Configure Mode	Function Type
AC Conducted Emission	1/2	Mode 1: GSM850 Idle + Bluetooth Idle + WLAN Idle + USB Cable (Charging from Adapter) + Earphone + Camera <Fig. 1> Mode 2: GSM1900 Idle + Bluetooth Idle + WLAN Idle + USB Cable (Charging from Adapter) + Earphone + MPEG4 <Fig. 1> Mode 3: WCDMA Band V Idle + Bluetooth Idle + WLAN Idle + USB Cable (Charging from Adapter) + Earphone + FM Rx <Fig. 2> Mode 4: WCDMA Band II Idle + Bluetooth Idle + WLAN Idle + USB Cable (Data Link with PC) + Earphone + GPS Rx <Fig. 3>
Radiated Emissions < 1GHz	1/2	Mode 1: GSM850 Idle + Bluetooth Idle + WLAN Idle + USB Cable (Charging from Adapter) + Earphone + Camera <Fig. 1> Mode 2: GSM1900 Idle + Bluetooth Idle + WLAN Idle + USB Cable (Charging from Adapter) + Earphone + MPEG4 <Fig. 1> Mode 3: WCDMA Band V Idle + Bluetooth Idle + WLAN Idle + USB Cable (Charging from Adapter) + Earphone + FM Rx <Fig. 2> Mode 4: WCDMA Band II Idle + Bluetooth Idle + WLAN Idle + USB Cable (Data Link with PC) + Earphone + GPS Rx <Fig. 3>
Radiated Emissions ≥ 1GHz	2	Mode 1: WCDMA Band II Idle + Bluetooth Idle + WLAN Idle + USB Cable (Data Link with PC) + Earphone + GPS Rx <Fig. 3>
Remark: <ol style="list-style-type: none"> The worst case of AC Conducted Emission is mode 3, and the USB link mode of AC Conducted Emission is mode4; the test data of these modes were reported. The worst case of Radiated Emissions is mode 4, and the USB link mode of Radiated Emissions is also mode4; the test data of this mode was reported. Link with PC means data application transferred mode between EUT and PC. 		

2.2. Connection Diagram of Test System

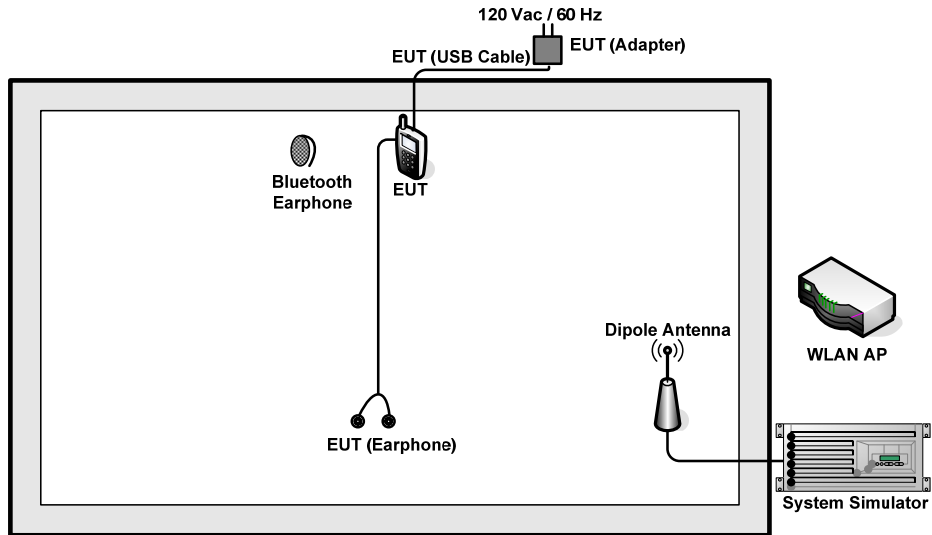

<Fig. 1>

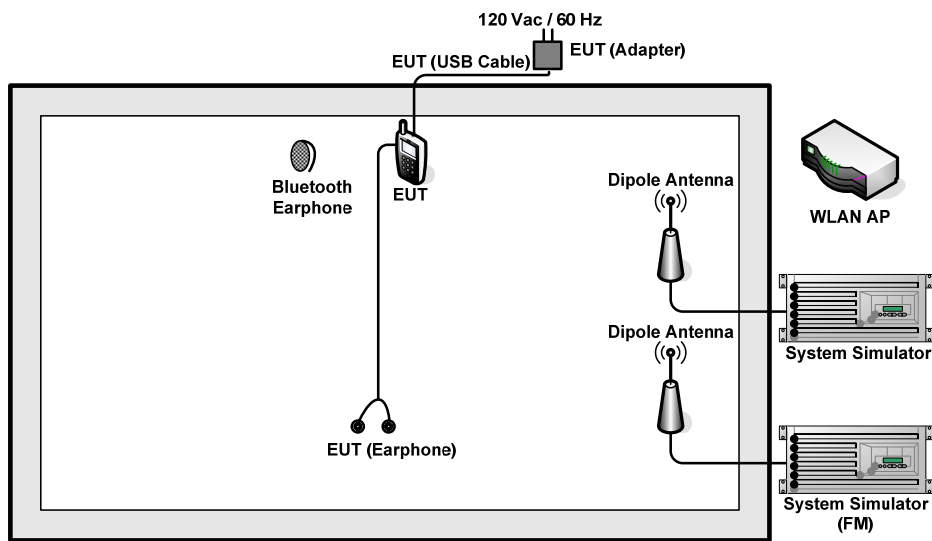

<Fig. 2>

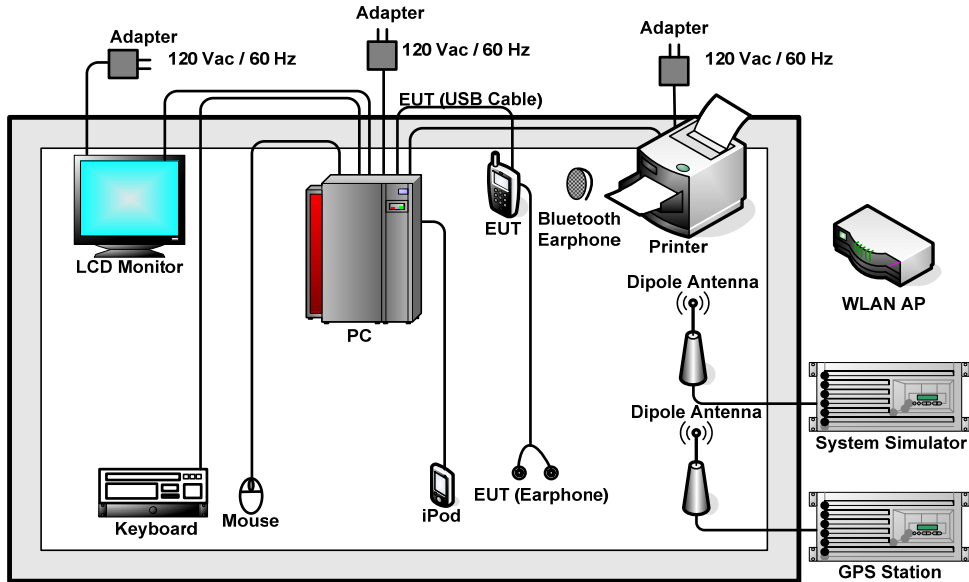

<Fig. 3>

2.3. Support Unit used in test configuration and system

Item	Equipment	Trade Name	Model Name	FCC ID	Data Cable	Power Cord
1.	System Simulator	Agilent	E5515C	N/A	N/A	Unshielded, 1.8 m
2.	System Simulator (FM)	R&S	CMU 200	N/A	N/A	Unshielded, 1.8 m
3.	GPS Station	T&E	GS-50	N/A	N/A	Unshielded, 1.8 m
4.	WLAN AP	Netcore	NW616	N/A	N/A	Unshielded, 1.8 m
5.	WLAN AP	D-Link	DIR-615	N/A	N/A	Unshielded, 1.8 m
6.	Bluetooth Earphone	Nokia	BH-108	N/A	N/A	N/A
7.	PC	DELL	OPTIPLEX 390	FCC DoC	N/A	Unshielded, 1.8 m
8.	Monitor	DELL	IN1940MWB	FCC DoC	Shielded, 1.2 m	Unshielded, 1.8 m
9.	Mouse	DELL	MS111-L	FCC DoC	Shielded, 1.5 m	N/A
10.	Keyboard	DELL	KB212-B	FCC DoC	Shielded, 1.5 m	N/A
11.	Printer	Samsung	ML-1610	FCC DoC	Unshielded, 1.8 m	Unshielded, 1.8 m
12.	iPod	Apple	MC525 ZP/A	FCC DoC	Shielded, 1.0 m	N/A

2.4. EUT Operation Test Setup

The EUT was in GSM or WCDMA idle mode during the testing. The EUT was synchronized to the BCCH, and is in continuous receiving mode by setting system simulator's paging reorganization.

At the same time, the EUT was attached to the Bluetooth earphone or WLAN AP, and the following programs installed in the EUT were programmed during the test.

1. Execute the program, "Winthrax" under WIN7 installed in PC for files transfer with EUT via USB cable.
2. Turn on GPS function to make the EUT receive continuous signals from GPS station.
3. Turn on FM function to make the EUT receive continuous signals from system simulator (FM).
4. Execute "Video player" to play MPEG4 files.
5. Turn on camera to capture images.

3. Test Result

3.1. Test of AC Conducted Emission Measurement

3.1.1 Limits of AC Conducted Emission

For equipment that is designed to be connected to the public utility (AC) power line, the radio frequency voltage that is conducted back onto the AC power line on any frequency or frequencies within the band 150 kHz to 30 MHz shall not exceed the limits in the following table.

Frequency of emission (MHz)	Conducted limit (dBuV)	
	Quasi-peak	Average
0.15-0.5	66 to 56*	56 to 46*
0.5-5	56	46
5-30	60	50

*Decreases with the logarithm of the frequency.

3.1.2 Measuring Instruments

See list of measuring instruments of this test report.

3.1.3 Test Procedure

1. The EUT was placed 0.4 meter from the conducting wall of the shielding room was kept at least 80 centimeters from any other grounded conducting surface.
2. Connect EUT to the power mains through a line impedance stabilization network (LISN).
3. All the support units are connecting to the other LISN.
4. The LISN provides 50 ohm coupling impedance for the measuring instrument.
5. The FCC states that a 50 ohm, 50 microhenry LISN should be used.
6. Both sides of AC line were checked for maximum conducted interference.
7. The frequency range from 150 kHz to 30 MHz was searched.
8. Set the test-receiver system to Peak Detect Function and specified bandwidth with Maximum Hold Mode.

3.1.4 Test Setup

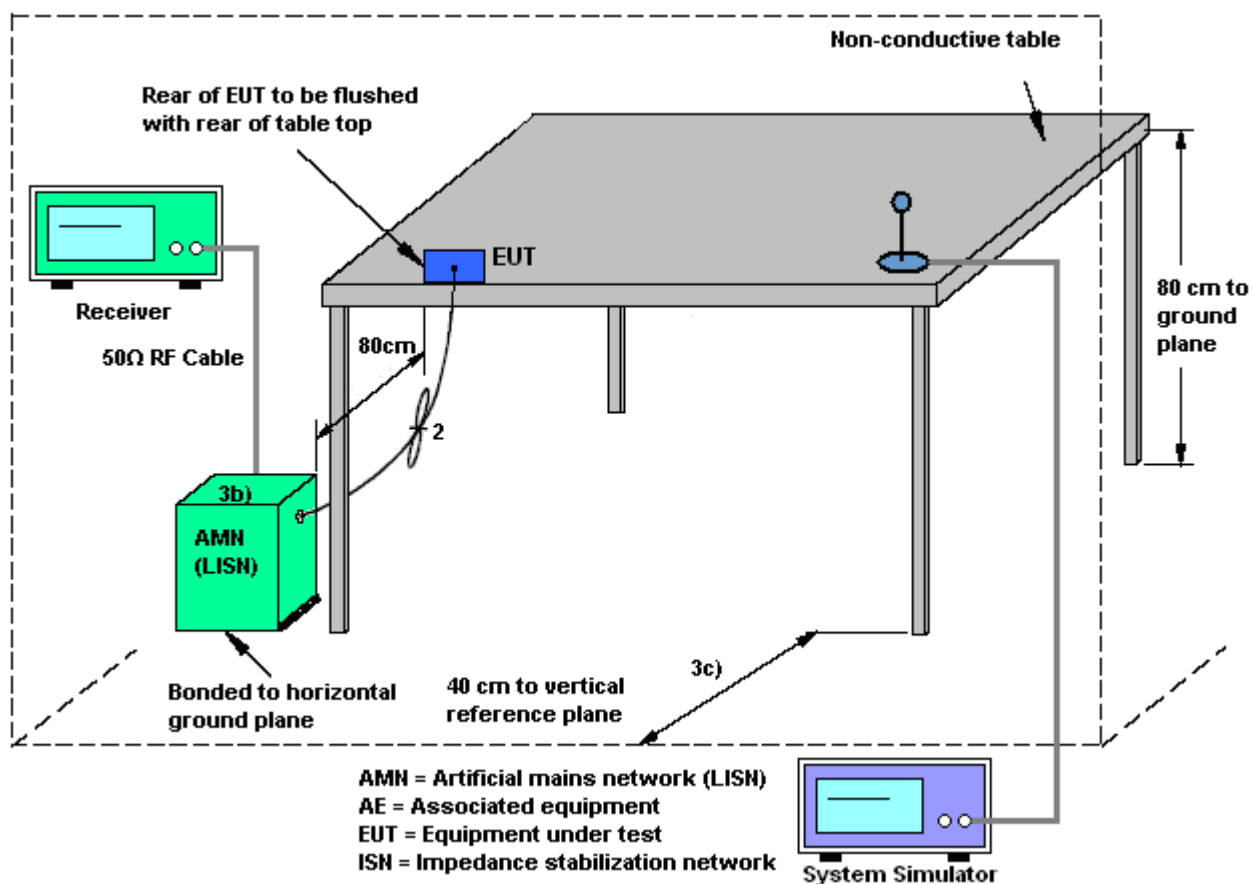

3.1.5 Test Result of AC Conducted Emission

Test Mode :	Mode 3	Temperature :	24~25°C
Test Engineer :	Leo Liao	Relative Humidity :	50~51%
Test Voltage :	120Vac / 60Hz	Phase :	Line
Function Type :	WCDMA Band V Idle + Bluetooth Idle + WLAN Idle + USB Cable (Charging from Adapter) + Earphone + FM Rx		
Remark :	All emissions not reported here are more than 10 dB below the prescribed limit.		

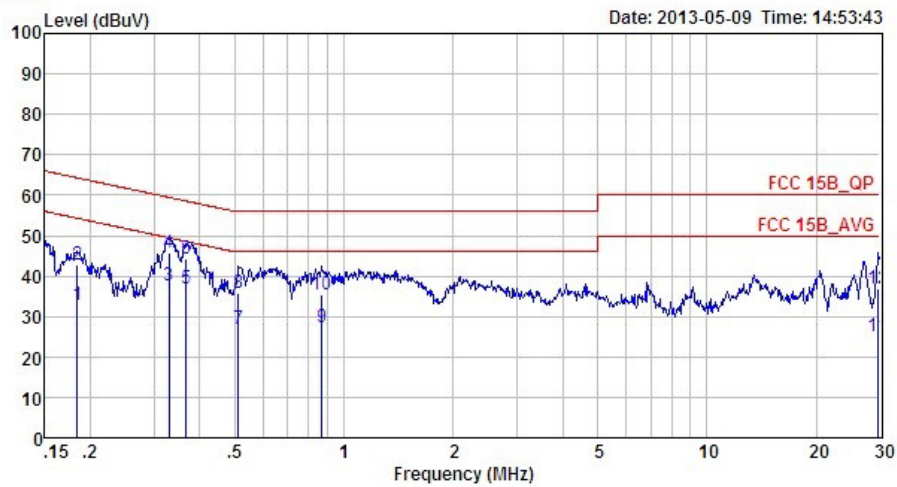

Site : CO01-SZ
 Condition: FCC 15B_QP LISN_L_2000601 LINE
 Project : (FC) 342511
 Mode : Mode 3

	Freq	Level	Over Limit	Limit Line	Read Level	LISN Factor	Cable Loss	Remark
	MHz	dBuV	dB	dBuV	dBuV	dB	dB	
1	0.18	32.78	-21.50	54.28	22.70	0.03	10.05	Average
2	0.18	42.68	-21.60	64.28	32.60	0.03	10.05	QP
3 *	0.33	37.79	-11.65	49.44	27.70	0.02	10.07	Average
4	0.33	45.69	-13.75	59.44	35.60	0.02	10.07	QP
5	0.37	36.89	-11.67	48.56	26.80	0.02	10.07	Average
6	0.37	44.29	-14.27	58.56	34.20	0.02	10.07	QP
7	0.51	27.11	-18.89	46.00	17.00	0.02	10.09	Average
8	0.51	35.91	-20.09	56.00	25.80	0.02	10.09	QP
9	0.87	27.43	-18.57	46.00	17.30	0.02	10.11	Average
10	0.87	35.53	-20.47	56.00	25.40	0.02	10.11	QP
11	29.68	25.03	-24.97	50.00	13.91	0.64	10.48	Average
12	29.68	36.83	-23.17	60.00	25.71	0.64	10.48	QP



Test Mode :	Mode 3	Temperature :	24~25°C
Test Engineer :	Leo Liao	Relative Humidity :	50~51%
Test Voltage :	120Vac / 60Hz	Phase :	Neutral
Function Type :	WCDMA Band V Idle + Bluetooth Idle + WLAN Idle + USB Cable (Charging from Adapter) + Earphone + FM Rx		
Remark :	All emissions not reported here are more than 10 dB below the prescribed limit.		

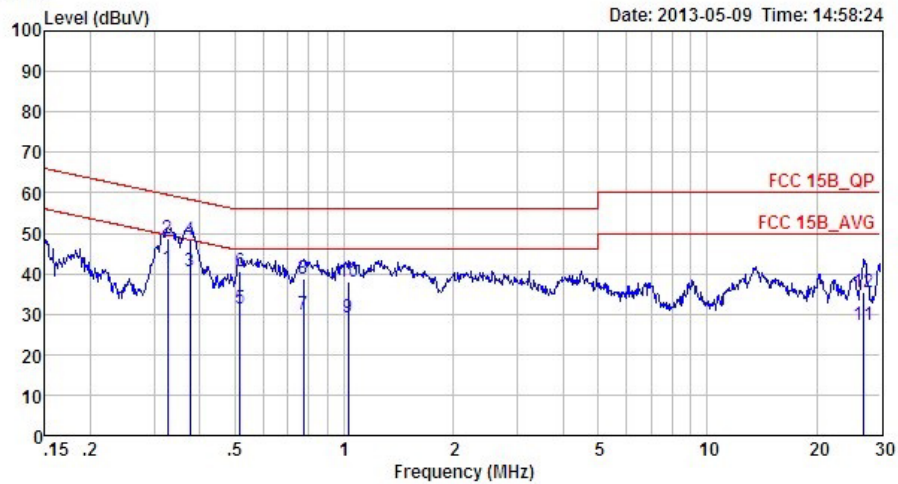

Site : CO01-SZ
 Condition: FCC 15B_QP LISN_N_2000601 NEUTRAL
 Project : (FC) 342511
 Mode : Mode 3

	Freq	Level	Over Limit	Read	LISN	Cable	Remark
	MHz	dBuV	dB	dBuV	dB	dB	
1	0.33	41.38	-8.15	49.53	31.29	0.02	Average
2	0.33	48.58	-10.95	59.53	38.49	0.02	QP
3 *	0.38	40.69	-7.65	48.34	30.60	0.02	Average
4	0.38	48.19	-10.15	58.34	38.10	0.02	QP
5	0.52	31.50	-14.50	46.00	21.39	0.02	Average
6	0.52	40.60	-15.40	56.00	30.49	0.02	QP
7	0.77	29.92	-16.08	46.00	19.80	0.02	Average
8	0.77	38.92	-17.08	56.00	28.80	0.02	QP
9	1.03	29.34	-16.66	46.00	19.21	0.02	Average
10	1.03	37.84	-18.16	56.00	27.71	0.02	QP
11	26.98	27.42	-22.58	50.00	16.10	0.89	Average
12	26.98	35.52	-24.48	60.00	24.20	0.89	QP



Test Mode :	Mode 4	Temperature :	24~25°C
Test Engineer :	Leo Liao	Relative Humidity :	50~51%
Test Voltage :	120Vac / 60Hz	Phase :	Line
Function Type :	WCDMA Band II Idle + Bluetooth Idle + WLAN Idle + USB Cable (Data Link with PC) + Earphone + GPS Rx		
Remark :	All emissions not reported here are more than 10 dB below the prescribed limit.		

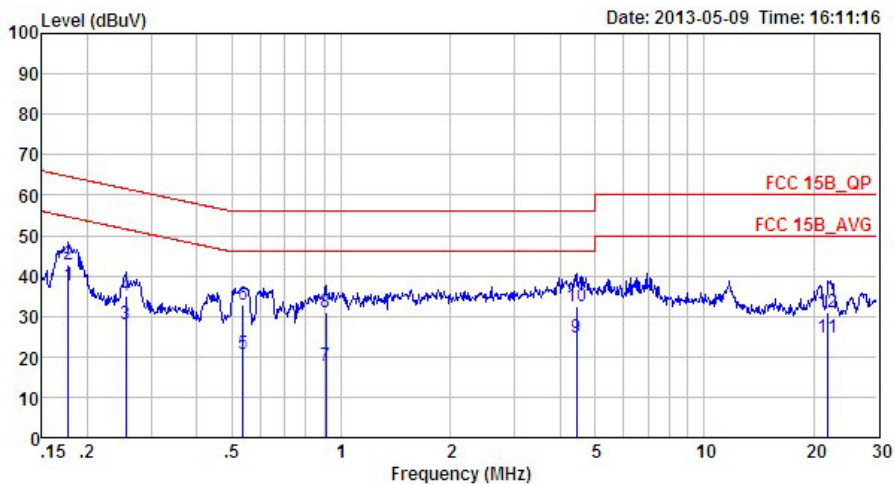

Site : CO01-SZ
 Condition: FCC 15B_QP LISN_L_2000601 LINE
 Project : (FD) 342511
 Mode : Mode 4

	Freq	Level	Over	Limit	Read	LISN	Cable	Remark
	MHz	dBuV	Limit	Line	Level	Factor	Loss	
			dB	dBuV	dBuV	dB	dB	
1 *	0.18	37.68	-16.91	54.59	27.60	0.03	10.05	Average
2	0.18	42.88	-21.71	64.59	32.80	0.03	10.05	QP
3	0.25	27.89	-23.71	51.60	17.81	0.02	10.06	Average
4	0.25	34.99	-26.61	61.60	24.91	0.02	10.06	QP
5	0.54	20.51	-25.49	46.00	10.40	0.02	10.09	Average
6	0.54	33.01	-22.99	56.00	22.90	0.02	10.09	QP
7	0.91	17.53	-28.47	46.00	7.39	0.03	10.11	Average
8	0.91	30.93	-25.07	56.00	20.79	0.03	10.11	QP
9	4.45	24.86	-21.14	46.00	14.61	0.06	10.19	Average
10	4.45	32.46	-23.54	56.00	22.21	0.06	10.19	QP
11	21.95	24.89	-25.11	50.00	14.00	0.41	10.48	Average
12	21.95	31.09	-28.91	60.00	20.20	0.41	10.48	QP



Test Mode :	Mode 4	Temperature :	24~25°C
Test Engineer :	Leo Liao	Relative Humidity :	50~51%
Test Voltage :	120Vac / 60Hz	Phase :	Neutral
Function Type :	WCDMA Band II Idle + Bluetooth Idle + WLAN Idle + USB Cable (Data Link with PC) + Earphone + GPS Rx		
Remark :	All emissions not reported here are more than 10 dB below the prescribed limit.		

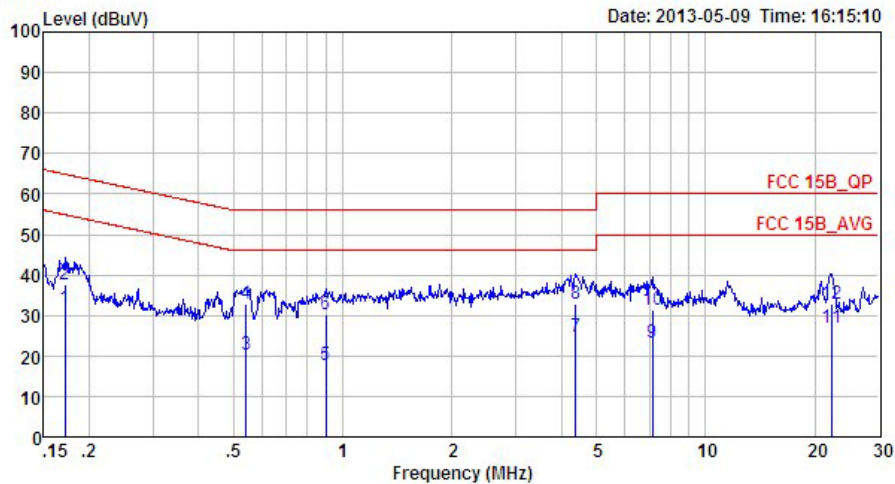

Site : C001-SZ
 Condition: FCC 15B_QP LISN_N_2000601 NEUTRAL
 Project : (FD) 342511
 Mode : Mode 4

	Freq	Level	Over Limit	Limit Line	Read Level	LISN Factor	Cable Loss	Remark
	MHz	dBuV	dB	dBuV	dBuV	dB	dB	
1	0.17	31.68	-23.22	54.90	21.61	0.02	10.05	Average
2	0.17	37.78	-27.12	64.90	27.71	0.02	10.05	QP
3	0.54	20.40	-25.60	46.00	10.29	0.02	10.09	Average
4	0.54	32.70	-23.30	56.00	22.59	0.02	10.09	QP
5	0.90	17.53	-28.47	46.00	7.40	0.02	10.11	Average
6	0.90	30.33	-25.67	56.00	20.20	0.02	10.11	QP
7 *	4.38	24.66	-21.34	46.00	14.40	0.07	10.19	Average
8	4.38	32.76	-23.24	56.00	22.50	0.07	10.19	QP
9	7.14	23.33	-26.67	50.00	13.00	0.13	10.20	Average
10	7.14	31.23	-28.77	60.00	20.90	0.13	10.20	QP
11	22.18	26.89	-23.11	50.00	15.80	0.62	10.47	Average
12	22.18	32.99	-27.01	60.00	21.90	0.62	10.47	QP

3.2. Test of Radiated Emission Measurement

3.2.1. Limit of Radiated Emission

The emissions from an unintentional radiator shall not exceed the field strength levels specified in the following table:

Frequency (MHz)	Field Strength (microvolts/meter)	Measurement Distance (meters)
30 – 88	100	3
88 – 216	150	3
216 - 960	200	3
Above 960	500	3

3.2.2. Measuring Instruments

See list of measuring instruments of this test report.

3.2.3. Test Procedures

1. The EUT was placed on a turntable with 0.8 meter above ground.
2. The EUT was set 3 meters from the interference receiving antenna, which was mounted on the top of a variable height antenna tower.
3. The table was rotated 360 degrees to determine the position of the highest radiation.
4. The antenna height is adjusted between one to four meters above ground to find the maximum value of the field strength for both horizontal polarization and vertical polarization of the antenna.
5. For each suspected emission, the EUT was arranged to its worst case and then tune the antenna tower (from 1 m to 4 m) and turntable (from 0 degree to 360 degrees) to find the maximum reading.
6. Set the test-receiver system to Peak Detect Function and specified bandwidth with Maximum Hold Mode.
7. If the emission level of the EUT in peak mode was 3 dB lower than the limit specified, peak values of EUT will be reported. Otherwise, the emission will be repeated by using the quasi-peak method and reported.
8. Emission level (dBuV/m) = 20 log Emission level (uV/m)
9. Corrected Reading: Antenna Factor + Cable Loss + Read Level - Preamp Factor= Level

3.2.4. Test Setup of Radiated Emission

For radiated emissions from 30MHz to 1GHz

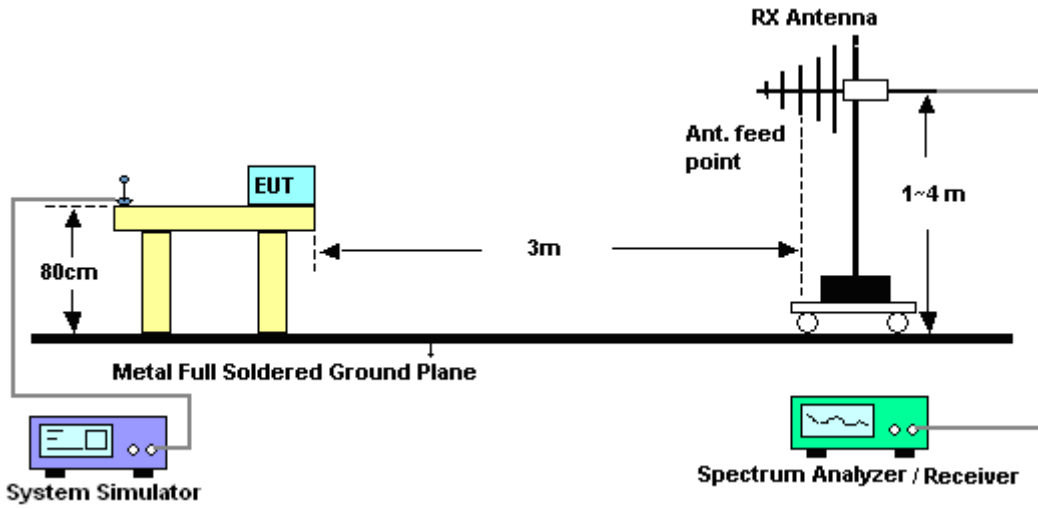

For radiated emissions above 1GHz

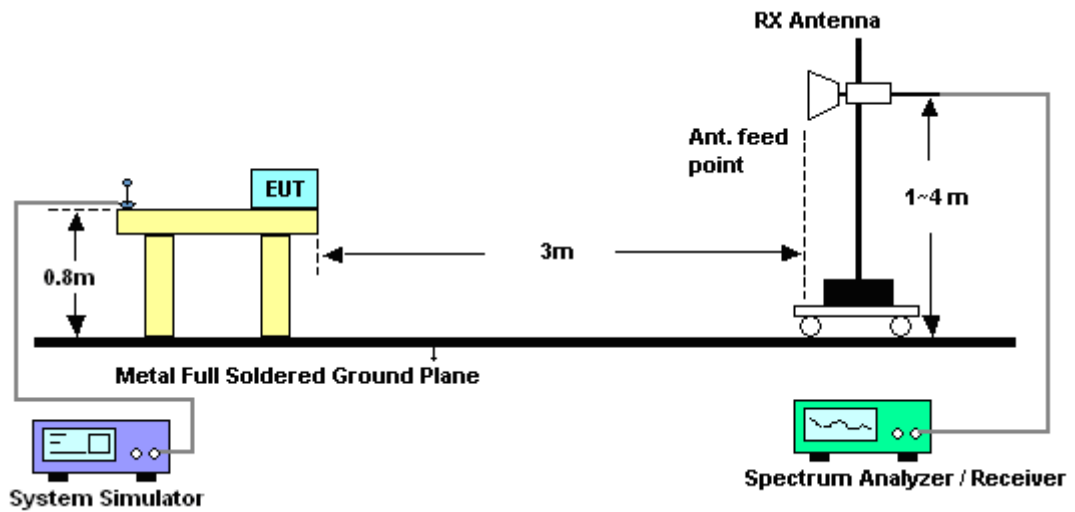



3.2.5. Test Result of Radiated Emission

Test Mode :	Mode 4	Temperature :	24~25°C
Test Engineer :	Robin Luo	Relative Humidity :	49~50%
Test Distance :	3m	Polarization :	Horizontal
Function Type :	WCDMA Band II Idle + Bluetooth Idle + WLAN Idle + USB Cable (Data Link with PC) + Earphone + GPS Rx		

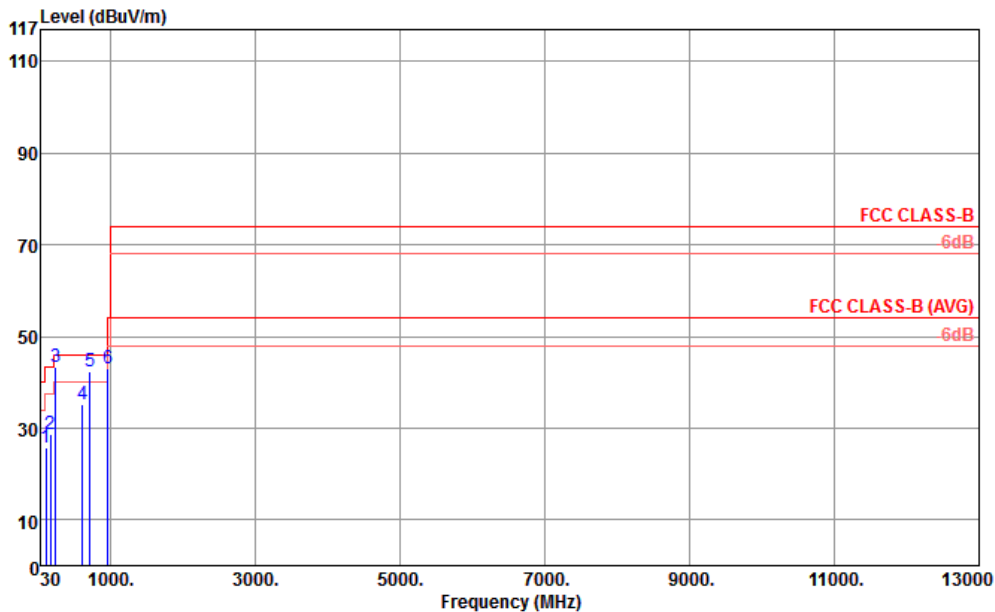

Site : 03CH01-SZ
 Condition : FCC CLASS-B 3m LF_ANT_121103 HORIZONTAL
 Project : (FC)342511
 Mode : Mode 4

	Freq	Level	Over Limit	Limit Line	ReadAntenna Level	Antenna Factor	Cable Loss	Preamp Factor	A/Pos	T/Pos	Remark
	MHz	dBuV/m	dB	dBuV/m	dBuV	dB/m	dB	dB	cm	deg	
1	103.44	25.90	-17.60	43.50	43.89	11.50	1.17	30.66	---	---	Peak
2	165.81	28.81	-14.69	43.50	48.09	9.90	1.27	30.45	---	---	Peak
3 Q	240.06	43.44	-2.56	46.00	60.10	11.90	1.64	30.20	200	23	QP
4 P	615.00	35.19	-10.81	46.00	42.99	19.08	2.30	29.18	---	---	Peak
5 !	720.00	42.44	-3.56	46.00	49.00	20.00	2.48	29.04	100	320	QP
6	960.10	42.90	-11.10	54.00	47.01	21.80	2.81	28.72	---	---	Peak



Test Mode :	Mode 4	Temperature :	24~25°C
Test Engineer :	Robin Luo	Relative Humidity :	49~50%
Test Distance :	3m	Polarization :	Vertical
Function Type :	WCDMA Band II Idle + Bluetooth Idle + WLAN Idle + USB Cable (Data Link with PC) + Earphone + GPS Rx		

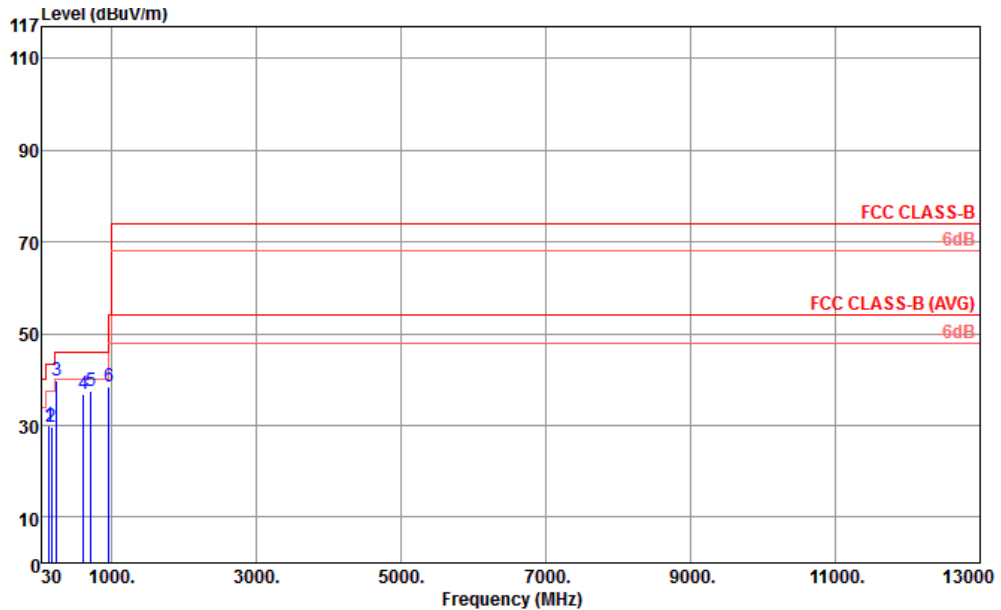

Site : 03CH01-SZ
 Condition : FCC CLASS-B 3m LF_ANT_121103 VERTICAL
 Project : (FC)342511
 Mode : Mode 4

	Freq	Level	Over Limit	Limit Line	ReadAntenna Level	Cable Loss	Preamp Factor	A/Pos	T/Pos	Remark	
	MHz	dBuV/m	dB	dBuV/m	dBuV	dB/m	dB	dB	cm	deg	
1	134.22	29.99	-13.51	43.50	47.20	12.10	1.24	30.55	---	---	Peak
2	165.81	29.51	-13.99	43.50	48.79	9.90	1.27	30.45	---	---	Peak
3 P	242.76	39.66	-6.34	46.00	56.20	12.00	1.65	30.19	100	360	Peak
4	615.00	36.67	-9.33	46.00	44.47	19.08	2.30	29.18	---	---	Peak
5	720.00	37.63	-8.37	46.00	44.19	20.00	2.48	29.04	---	---	Peak
6	960.10	38.60	-15.40	54.00	42.71	21.80	2.81	28.72	---	---	Peak



4. List of Measuring Equipment

Instrument	Manufacturer	Model No.	Serial No.	Characteristics	Calibration Date	Test Date	Due Date	Remark
ESCIO TEST Receiver	R&S	1142.8007.03	100724	9kHz~3GHz	Mar. 28, 2013	May 09, 2013	Mar. 27, 2014	Conduction (CO01-SZ)
AC LISN	EMCO	3816/2SH	00103912	9kHz~30MHz	Mar. 28, 2013	May 09, 2013	Mar. 27, 2014	Conduction (CO01-SZ)
AC LISN (for auxiliary equipment)	EMCO	3816/2SH	00103892	9kHz~30MHz	Mar. 28, 2013	May 09, 2013	Mar. 27, 2014	Conduction (CO01-SZ)
AC Power Source	Chroma	61602	616020000891	N/A	Nov. 20, 2012	May 09, 2013	Nov. 19, 2013	Conduction (CO01-SZ)
AC Filter	ETS-LINDGREN	LRE-2030/PE N 256260	00093783	N/A	N/A	May 09, 2013	N/A	Conduction (CO01-SZ)
AC Filter	ETS-LINDGREN	LRE-2030/PE N 256260	00097973	N/A	N/A	May 09, 2013	N/A	Conduction (CO01-SZ)
ESCI TEST Receiver	R&S	ESCI	100724	9kHz~3GHz	Mar. 28, 2013	Jun. 25, 2013	Mar. 27, 2014	Radiation (03CH01-SZ)
Spectrum Analyzer	R&S	FSP30	101362	9kHz~30GHz	Oct. 11, 2012	Jun. 25, 2013	Oct. 10, 2013	Radiation (03CH01-SZ)
Double Ridge Horn Antenna	ETS Lindgren	3117	00119436	1GHz~18GHz	Oct. 12, 2012	Jun. 25, 2013	Oct. 11, 2013	Radiation (03CH01-SZ)
Bilog Antenna	SCHAFFNER	CBL6112B	2614	30MHz~2GHz	Nov. 03, 2012	Jun. 25, 2013	Nov. 02, 2013	Radiation (03CH01-SZ)
Amplifier	ADVANTEST	BB525C	E9007003	9kHz~3GHz Gain 30dB	Mar. 28, 2013	Jun. 25, 2013	Mar. 27, 2014	Radiation (03CH01-SZ)
Amplifier	Yiai	AV3860B	04030	2GHz~26.5GHz	Mar. 28, 2013	Jun. 25, 2013	Mar. 27, 2014	Radiation (03CH01-SZ)
SHF-EHF-Horn	Schwarzbeck	BBHA9170	BBHA9170249	14GHz~40GHz	Nov. 23, 2012	Jun. 25, 2013	Nov. 22, 2013	Radiation (03CH01-SZ)
Loop Antenna	R&S	HFH2-Z2	100321	9KHz~30MHZ	Oct. 22, 2012	Jun. 25, 2013	Oct. 21, 2013	Radiation (03CH01-SZ)
Turn Table	EM Electronics	EM 1000	N/A	0 ~ 360 degree	N/A	Jun. 14, 2013	N/A	Radiation (03CH01-SZ)
Antenna Mast	EM Electronics	EM 1000	N/A	1 m - 4 m	N/A	Jun. 14, 2013	N/A	Radiation (03CH01-SZ)

5. Uncertainty of Evaluation

Uncertainty of Conducted Emission Measurement (150 KHz ~ 30 MHz)

Measuring Uncertainty for a Level of Confidence of 95% ($U = 2Uc(y)$)	2.26
---	------

Uncertainty of Radiated Emission Measurement (30 MHz ~ 1000 MHz)

Measuring Uncertainty for a Level of Confidence of 95% ($U = 2Uc(y)$)	2.54
---	------

Uncertainty of Radiated Emission Measurement (1 GHz ~ 40 GHz)

Measuring Uncertainty for a Level of Confidence of 95% ($U = 2Uc(y)$)	4.72
---	------



Appendix A. Photographs of EUT

Please refer to Sporton report number EP342511 as below.