

FCC Radio Test Report

FCC ID: YDB-SNOMD375

This report concerns (check one): Original Grant Class II Change

Project No. : 1508017
Equipment : VoIP Phone
Model Name : D375, snom D375, snom 375, 375
Applicant : Snom technology AG
Address : Wittestr. 30 G, Berlin, Germany 13509.

Date of Receipt : Aug. 03, 2015
Date of Test : Aug. 03, 2015 ~ Sep. 02, 2015
Issued Date : Sep. 07, 2015
Tested by : BTL Inc.

Testing Engineer : Rush Kao
(Rush Kao)

Technical Manager : Jeff Yang
(Jeff Yang)

Authorized Signatory : Andy Chiu
(Andy Chiu)

B T L I N C .

B1, No.37, Lane 365, Yang Guang St.,
Nei-Hu District, Taipei City 114, Taiwan.
TEL:+886-2-2657-3299 FAX: +886-2- 2657-3331

Declaration

BTL represents to the client that testing is done in accordance with standard procedures as applicable and that test instruments used has been calibrated with the standards traceable to National Measurement Laboratory (**NML**) of **R.O.C**, or National Institute of Standards and Technology (**NIST**) of **U.S.A**.

BTL's reports apply only to the specific samples tested under conditions. It is manufacture's responsibility to ensure that additional production units of this model are manufactured with the identical electrical and mechanical components. **BTL** shall have no liability for any declarations, inferences or generalizations drawn by the client or others from **BTL** issued reports.

BTL's report must not be used by the client to claim product certification, approval, or endorsement by NVLAP, NIST, or any agency of the Federal Government.

This report is the confidential property of the client. As a mutual protection to the clients, the public and **BTL-self**, extracts from the test report shall not be reproduced except in full with **BTL's** authorized written approval.

BTL's laboratory quality assurance procedures are in compliance with the **ISO Guide 17025** requirements, and accredited by the conformity assessment authorities listed in this test report.

Limitation

For the use of the authority's logo is limited unless the Test Standard(s)/Scope(s)/Item(s) mentioned in this test report is (are) included in the conformity assessment authorities acceptance respective.

Table of Contents	Page
1 . CERTIFICATION	6
2 . SUMMARY OF TEST RESULTS	7
2.1 TEST FACILITY	7
2.2 MEASUREMENT UNCERTAINTY	8
3 . GENERAL INFORMATION	9
3.1 GENERAL DESCRIPTION OF EUT	9
3.2 DESCRIPTION OF TEST MODES	11
3.3 TABLE OF PARAMETERS OF TEXT SOFTWARE SETTING	12
3.4 BLOCK DIAGRAM SHOWING THE CONFIGURATION OF SYSTEM TESTED	13
3.5 DESCRIPTION OF SUPPORT UNITS	13
4 . EMC EMISSION TEST	14
4.1 CONDUCTED EMISSION MEASUREMENT	14
4.1.1 POWER LINE CONDUCTED EMISSION LIMITS	14
4.1.2 TEST PROCEDURE	14
4.1.3 DEVIATION FROM TEST STANDARD	14
4.1.4 TEST SETUP	15
4.1.5 EUT OPERATING CONDITIONS	15
4.1.6 EUT TEST CONDITIONS	15
4.1.7 TEST RESULTS	15
4.2 RADIATED EMISSION MEASUREMENT	16
4.2.1 RADIATED EMISSION LIMITS	16
4.2.2 TEST PROCEDURE	17
4.2.3 DEVIATION FROM TEST STANDARD	17
4.2.4 TEST SETUP	18
4.2.5 EUT OPERATING CONDITIONS	19
4.2.6 EUT TEST CONDITIONS	19
4.2.7 TEST RESULTS (9KHZ TO 30MHZ)	19
4.2.8 TEST RESULTS (BETWEEN 30MHZ TO 1000 MHZ)	20
4.2.9 TEST RESULTS (ABOVE 1000 MHZ)	20
5 . BANDWIDTH TEST	21
5.1 APPLIED PROCEDURES / LIMIT	21
5.1.1 TEST PROCEDURE	21
5.1.2 DEVIATION FROM STANDARD	21
5.1.3 TEST SETUP	21
5.1.4 EUT OPERATION CONDITIONS	21
5.1.5 EUT TEST CONDITIONS	21
5.1.6 TEST RESULTS	21

Table of Contents	Page
6 . MAXIMUM OUTPUT POWER TEST	22
6.1 APPLIED PROCEDURES / LIMIT	22
6.1.1 TEST PROCEDURE	22
6.1.2 DEVIATION FROM STANDARD	22
6.1.3 TEST SETUP	22
6.1.4 EUT OPERATION CONDITIONS	22
6.1.5 EUT TEST CONDITIONS	22
6.1.6 TEST RESULTS	22
7 . ANTENNA CONDUCTED SPURIOUS EMISSION	23
!! HYPERLINK \L "_TOC429416384" 7.1 APPLIED PROCEDURES / LIMIT	23
7.1.1 TEST PROCEDURE	23
7.1.2 DEVIATION FROM STANDARD	23
7.1.3 TEST SETUP	23
7.1.4 EUT OPERATION CONDITIONS	23
7.1.5 EUT OPERATION CONDITIONS	23
7.1.6 TEST RESULTS	23
8 . POWER SPECTRAL DENSITY TEST	24
8.1 APPLIED PROCEDURES / LIMIT	24
8.1.1 TEST PROCEDURE	24
8.1.2 DEVIATION FROM STANDARD	24
8.1.3 TEST SETUP	24
8.1.4 EUT OPERATION CONDITIONS	24
8.1.5 EUT TEST CONDITIONS	24
8.1.6 TEST RESULTS	24
9 . MEASUREMENT INSTRUMENTS LIST	25
10 . EUT TEST PHOTO	27
ATTACHMENT A - CONDUCTED EMISSION	31
ATTACHMENT B - RADIATED EMISSION (9KHZ TO 30MHZ)	34
ATTACHMENT C - RADIATED EMISSION (30MHZ TO 1000MHZ)	36
ATTACHMENT D - RADIATED EMISSION (ABOVE 1000MHZ)	39
ATTACHMENT E - BANDWIDTH	52
ATTACHMENT F - MAXIMUM OUTPUT POWER TEST	55
ATTACHMENT G - ANTENNA CONDUCTED SPURIOUS EMISSION	56
ATTACHMENT H - POWER SPECTRAL DENSITY TEST	60

REPORT ISSUED HISTORY

Issued No.	Description	Issued Date
BTL-FCCP-2-1508017	Original Issue.	Sep. 07, 2015

1. CERTIFICATION

Equipment : VoIP Phone
Brand Name : Snom
Model Name : D375, snom D375, snom 375, 375
Applicant : Snom technology AG
Manufacturer : SERCOMM CORP
Address : 3F 81 YUYI RD CHU-NAN MIAO-LI, 350 TAIWAN
Factory : SERCOMM CORP
Address : 3F 81 YUYI RD CHU-NAN MIAO-LI, 350 TAIWAN
Date of Test : Aug. 03, 2015 ~ Sep. 02, 2015
Standard(s) : FCC Part15, Subpart C :2014 (15.247) / ANSI C63.10-2013

The above equipment has been tested and found compliance with the requirement of the relative standards by BTL Inc.

The test data, data evaluation, and equipment configuration contained in our test report (Ref No. BTL-FCCP-2-1508017) were obtained utilizing the test procedures, test instruments, test sites that has been accredited by the Authority of TAF according to the ISO-17025 quality assessment standard and technical standard(s).

2. SUMMARY OF TEST RESULTS

Test procedures according to the technical standard(s):

Applied Standard(s): FCC Part15 (15.247) , Subpart C: 2014				
Standard(s)	Section	Test Item	Judgment	Remark
	15.207	Conducted Emission	PASS	
	15.247(d)	Antenna conducted Spurious Emission	PASS	
	15.247(a)(2)	6dB Bandwidth	PASS	
	15.247(b)(3)	Peak Output Power	PASS	
	15.247(e)	Power Spectral Density	PASS	
	15.203	Antenna Requirement	PASS	
	15.209/15.205	Transmitter Radiated Emissions	PASS	

NOTE:

- (1) "N/A" denotes test is not applicable to this device.
- (2) The test follows FCC KDB Publication No. 558074 D01 DTS Meas Guidance v03r02 (Measurement Guidelines of DTS)

2.1 TEST FACILITY

Conducted emission Test:

C05: (VCCI RN: C-4742; FCC RN:965108; FCC DN:TW1082)
No. 68-1, Ln. 169, Sec.2, Datong Rd., Xizhi Dist., New Taipei City 221, Taiwan

Radiated emission Test (Below 1 GHz):

CB08: (FCC RN: 614388; FCC DN: TW1054; IC Assigned Code: 4428C-1)
1F., No. 61, Ln. 77, Sing-ai Rd., Neihu Dist., Taipei City 114, Taiwan (R.O.C.)

Radiated emission Test (Above 1 GHz):

CB08: (VCCI RN: G-91; FCC RN: 614388; FCC DN: TW1054; IC Assigned Code: 4428C-1)
1F., No. 61, Ln. 77, Sing-ai Rd., Neihu Dist., Taipei City 114, Taiwan (R.O.C.)

2.2 MEASUREMENT UNCERTAINTY

The measurement uncertainty is not specified by FCC rules and Canada Industry for reference only.

The reported uncertainty of measurement $y \pm U$, where expanded uncertainty U is based on a standard uncertainty multiplied by a coverage factor of $k=2$, providing a level of confidence of approximately 95%.

The measurement instrumentation uncertainty considerations contained in CISPR 16-4-2.

The BTL measurement uncertainty is less than the CISPR 16-4-2 U_{CISPR} requirement.

A. Conducted Measurement :

Test Site	Method	Measurement Frequency Range	U , (dB)	Note
C05	CISPR	150 kHz ~ 30MHz	2.04	

B. Radiated Measurement :

Test Site	Method	Measurement Frequency Range	U , (dB)	Note
CB08 (3m)	CISPR	9kHz ~ 150kHz	4.00	
		150kHz ~ 30MHz	4.00	

Test Site	Method	Measurement Frequency Range	Ant.	U , (dB)	Note
CB08 (3m)	CISPR	30MHz ~ 200MHz	V	3.06	
		30MHz ~ 200MHz	H	2.58	
		200MHz ~ 1,000MHz	V	3.50	
		200MHz ~ 1,000MHz	H	3.10	

Test Site	Method	Measurement Frequency Range	Ant.	U , (dB)	Note
CB08 (3m)	CISPR	1GHz ~ 6GHz	V	4.14	
		1GHz ~ 6GHz	H	4.14	
		6GHz ~ 18GHz	V	5.34	
		6GHz ~ 18GHz	H	5.34	

Test Site	Method	Measurement Frequency Range	U , (dB)	Note
CB08 (3m)	CISPR	18 ~ 26.5 GHz	4.66	
		26.5 ~ 40 GHz	4.74	

Note: Unless specifically mentioned, the uncertainty of measurement has not been taken into account to declare the compliance or non-compliance to the specification.

Our calculated Measurement Instrumentation Uncertainty is shown in the tables above. These are our U_{lab} values in CISPR 16-4-2 terminology.

Since Table 1 of CISPR 16-4-2 has values of measurement instrumentation uncertainty, called U_{CISPR} , as follows:

Conducted Disturbance (mains port) – 150 kHz – 30 MHz : 3.6 dB

Radiated Disturbance (electric field strength on an open area test site or alternative test site) – 30 MHz – 1000 MHz : 5.2 dB

It can be seen that our U_{lab} values are smaller than U_{CISPR} .

3. GENERAL INFORMATION

3.1 GENERAL DESCRIPTION OF EUT

Equipment	VoIP Phone	
Brand Name	Snom	
Model Name	D375, snom D375, snom 375, 375	
Model Difference	Only differ in model name due to marketing purpose.	
Product Description	Operation Frequency	2402~2480 MHz
	Modulation Technology	GFSK(1Mbps)
	Bit Rate of Transmitter	
	Output Power (Max.)	6.98 dBm (1Mbps)
Power Source	#1 DC Voltage supplied from AC/DC adapter (support unit). #2 Supplied from PoE.	
Power Rating	#1 I/P: AC 100-240V 0.3A 50-60Hz 23-32VA O/P: DC 5V 2.0A #2 DC 48V	

Note:

1. For a more detailed features description, please refer to the manufacturer's specifications or the user's manual.

2.

Channel List			
Channel	Frequency (MHz)	Channel	Frequency (MHz)
00	2402	20	2442
01	2404	21	2444
02	2406	22	2446
03	2408	23	2448
04	2410	24	2450
05	2412	25	2452
06	2414	26	2454
07	2416	27	2456
08	2418	28	2458
09	2420	29	2460
10	2422	30	2462
11	2424	31	2464
12	2426	32	2466
13	2428	33	2468
14	2430	34	2470
15	2432	35	2472
16	2434	36	2474
17	2436	37	2476
18	2438	38	2478
19	2440	39	2480

3. Table for Filed Antenna

Ant.	Brand	Model Name	Antenna Type	Connector	Gain (dBi)	Note
1		AT8010 -E2R9HAA	Chip	N/A	2.50	

3.2 DESCRIPTION OF TEST MODES

To investigate the maximum EMI emission characteristics generated from EUT, the test system was pre-scanning tested based on the consideration of following EUT operation mode or test configuration mode which possibly have effect on EMI emission level. Each of these EUT operation mode(s) or test configuration mode(s) mentioned above was evaluated respectively.

Pretest Mode	Description
Mode 1	TX Mode NOTE (1)
Mode 2	Bluetooth

The EUT system operated these modes were found to be the worst case during the pre-scanning test as following:

For Conducted Test	
Final Test Mode	Description
Mode 2	Bluetooth

For Radiated Test	
Final Test Mode	Description
Mode 1	TX Mode NOTE (1)

Note:

(1) The measurements are performed at the high, middle, low available channels.

3.3 TABLE OF PARAMETERS OF TEXT SOFTWARE SETTING

During testing channel & power controlling software provided by the customer was used to control the operating channel as well as the output power level. The RF output power selection is for the setting of RF output power expected by the customer and is going to be fixed on the firmware of the final end product power parameters of WLAN

Test Software Version	Terminal		
Frequency (MHz)	2402	2440	2480
BT LE	1	1	1

3.4 BLOCK DIAGRAM SHOWING THE CONFIGURATION OF SYSTEM TESTED

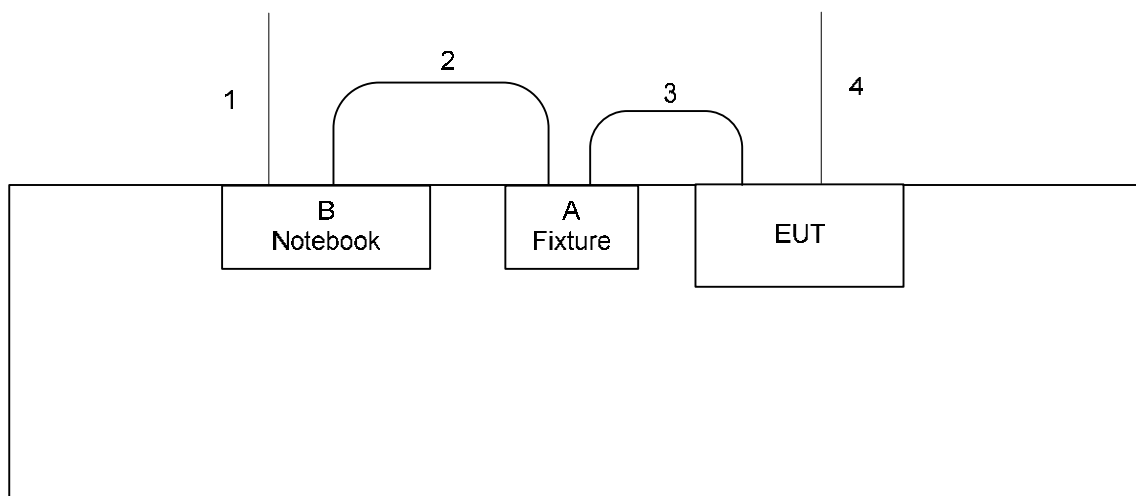

3.5 DESCRIPTION OF SUPPORT UNITS

The EUT has been tested as an independent unit together with other necessary accessories or support units. The following support units or accessories were used to form a representative test configuration during the tests.

Item	Equipment	Mfr/Brand	Model/Type No.	FCC ID/IC	Series No.	Note
A	Fixture	N/A	N/A	N/A	N/A	N/A
B	Notebook	ASUS	X450J	DOC	E8N0WU31377235F	N/A

Item	Shielded Type	Ferrite Core	Length	Note
1	YES	YES	1.5m	Power Line
2	YES	NO	1.8m	USB To RS-232 Cable
3	NO	NO	0.3m	Control Cable
4	NO	NO	1.3m	Power Line

Note:

- (1) For detachable type I/O cable should be specified the length in m in 『Length』 column.

4. EMC EMISSION TEST

4.1 CONDUCTED EMISSION MEASUREMENT

4.1.1 POWER LINE CONDUCTED EMISSION Limits (Frequency Range 150KHz-30MHz)

Frequency of Emission (MHz)	Conducted Limit (dB μ V)	
	Quasi-peak	Average
0.15 -0.5	66 to 56*	56 to 46*
0.50 -5.0	56	46
5.0 -30.0	60	50

Note:

- (1) The limit of " * " decreases with the logarithm of the frequency
- (2) The test result calculated as following:
 Measurement Value = Reading Level + Correct Factor
 Correct Factor = Antenna Factor + Cable Loss - Amplifier Gain(if use)
 Margin Level = Measurement Value - Limit Value

The following table is the setting of the receiver

Receiver Parameters	Setting
Attenuation	10 dB
Start Frequency	0.15 MHz
Stop Frequency	30 MHz
IF Bandwidth	9 kHz

4.1.2 TEST PROCEDURE

- a. The EUT was placed 0.8 meters from the horizontal ground plane with EUT being connected to the power mains through a line impedance stabilization network (LISN). All other support equipments powered from additional LISN(s). The LISN provide 50 Ohm/ 50uH of coupling impedance for the measuring instrument.
- b. Interconnecting cables that hang closer than 40 cm to the ground plane shall be folded back and forth in the center forming a bundle 30 to 40 cm long.
- c. I/O cables that are not connected to a peripheral shall be bundled in the center. The end of the cable may be terminated, if required, using the correct terminating impedance. The overall length shall not exceed 1 m.
- d. LISN at least 80 cm from nearest part of EUT chassis.
- e. For the actual test configuration, please refer to the related Item –EUT Test Photos.

4.1.3 DEVIATION FROM TEST STANDARD

No deviation

4.1.4 TEST SETUP

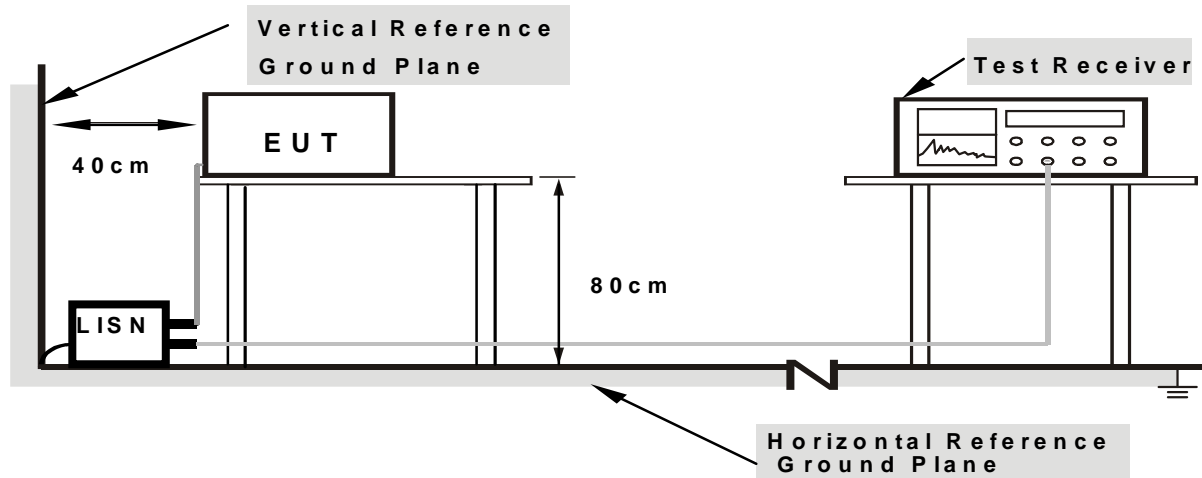

- Note:**
1. Support units were connected to second LISN.
 2. Both of LISNs (AMN) are 80 cm from EUT and at least 80 from other units and other metal planes

4.1.5 EUT OPERATING CONDITIONS

The EUT was configured for testing in a typical function (as a customer would normally use it), EUT was programmed to be in continuously transmitting/receiving data or hopping on mode.

4.1.6 EUT TEST CONDITIONS

Temperature: 26°C
 Relative Humidity: 59%
 Test Voltage: AC 120V/60Hz

4.1.7 TEST RESULTS

Please refer to the Attachment A.

Remark:

- (1) All readings are QP Mode value unless otherwise stated AVG in column of 『Note』. If the QP Mode Measured value compliance with the QP Limits and lower than AVG Limits, the EUT shall be deemed to meet both QP & AVG Limits and then only QP Mode was measured, but AVG Mode didn't perform. In this case, a “ * ” marked in AVG Mode column of Interference Voltage Measured.
- (2) Measuring frequency range from 150KHz to 30MHz.
- (3) “ N/A ” denotes test is not applicable to this device.

4.2 RADIATED EMISSION MEASUREMENT

4.2.1 RADIATED EMISSION LIMITS

In case the emission fall within the restricted band specified on 15.205(a), then the 15.209(a) limit in the table below has to be followed.

LIMITS OF RADIATED EMISSION MEASUREMENT (9KHz-1000MHz)

Frequency (MHz)	Field Strength (microvolts/meter)	Measurement Distance (meters)
0.009~0.490	2400/F(KHz)	300
0.490~1.705	24000/F(KHz)	30
1.705~30.0	30	30
30~88	100	3
88~216	150	3
216~960	200	3
960~1000	500	3

LIMITS OF RADIATED EMISSION MEASUREMENT (Above 1000MHz)

Frequency (MHz)	(dBuV/m) (at 3 meters)	
	PEAK	AVERAGE
Above 1000	74	54

Notes:

- (1) The limit for radiated test was performed according to FCC PART 15C.
- (2) The tighter limit applies at the band edges.
- (3) Emission level (dBuV/m)=20log Emission level (uV/m).
- (4) The test result calculated as following:
 Measurement Value = Reading Level + Correct Factor
 Correct Factor = Antenna Factor + Cable Loss - Amplifier Gain(if use)
 Margin Level = Measurement Value - Limit Value

Spectrum Parameter	Setting
Attenuation	Auto
Start Frequency	1000 MHz
Stop Frequency	10th carrier harmonic
RBW / VBW (Emission in restricted band)	RBW 1MHz VBW 3MHz peak detector for Pk value RMS detector for AV value

Receiver Parameter	Setting
Attenuation	Auto
Start ~ Stop Frequency	9KHz~90KHz for PK/AVG detector
Start ~ Stop Frequency	90KHz~110KHz for QP detector
Start ~ Stop Frequency	110KHz~490KHz for PK/AVG detector
Start ~ Stop Frequency	490KHz~30MHz for QP detector
Start ~ Stop Frequency	30MHz~1000MHz for QP detector

4.2.2 TEST PROCEDURE

- a. The measuring distance of at 3 m shall be used for measurements. The EUT was placed on the top of a rotating table 0.8 meter above the ground at a 3 meter semi-anechoic chamber. The table was rotated 360 degrees to determine the position of the highest radiation.(below 1GHz)
- b. The measuring distance of at 3 m shall be used for measurements. The EUT was placed on the top of a rotating table 1.5 meter above the ground at a 3 meter semi-anechoic chamber. The table was rotated 360 degrees to determine the position of the highest radiation.(above 1GHz)
- c. The height of the equipment or of the substitution antenna shall be 0.8 m or 1.5m, the height of the test antenna shall vary between 1 m to 4 m. Both horizontal and vertical polarizations of the antenna are set to make the measurement.
- d. For each suspected emission, the EUT was arranged to its worst case and then the antenna was tuned to heights find the maximum reading (used Bore sight function).
- e. The receiver system was set to peak and average detect function and specified bandwidth with maximum hold mode when the test frequency is above 1GHz.
- f. The initial step in collecting conducted emission data is a receiver peak detector mode pre-scanning the measurement frequency range. Significant peaks are then marked and then Quasi Peak detector mode re-measured.
- g. All readings are Peak unless otherwise stated QP in column of Note. Peak denotes that the Peak reading compliance with the QP Limits and then QP Mode measurement didn't perform. (below 1GHz)
- h. All readings are Peak Mode value unless otherwise stated AVG in column of Note. If the Peak Mode Measured value compliance with the Peak Limits and lower than AVG Limits, the EUT shall be deemed to meet both Peak & AVG Limits and then only Peak Mode was measured, but AVG Mode didn't perform. (above 1GHz)
- i. For the actual test configuration, please refer to the related Item - Block Diagram of system tested (please refer to 3.3).

4.2.3 DEVIATION FROM TEST STANDARD

No deviation

4.2.4 TEST SETUP

(A) Radiated Emission Test Set-Up Frequency Below 1 GHz

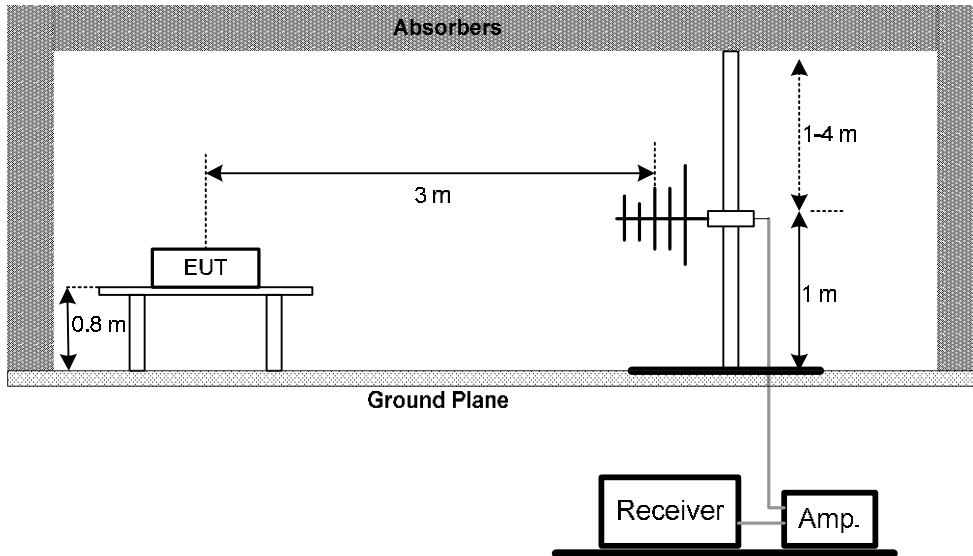

(B) Radiated Emission Test Set-Up Frequency Above 1 GHz

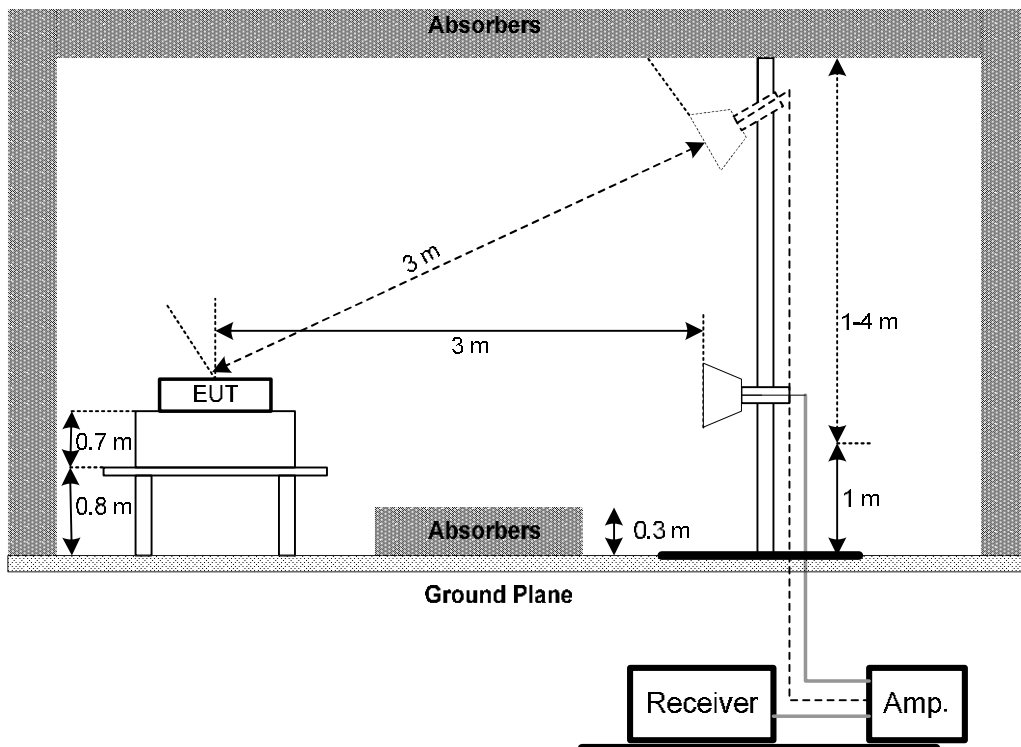

(C) For radiated emissions below 30MHz

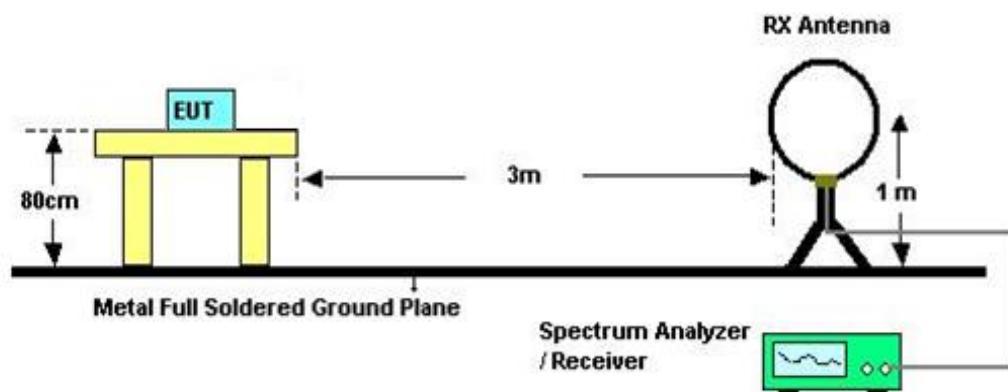

4.2.5 EUT OPERATING CONDITIONS

The EUT tested system was configured as the statements of 4.1.5 **Unless** otherwise a special operating condition is specified in the follows during the testing.

4.2.6 EUT TEST CONDITIONS

Temperature: 24°C

Relative Humidity: 60%

Test Voltage: AC 120V/60Hz

4.2.7 TEST RESULTS (9KHZ TO 30MHZ)

Please refer to the Attachment B

Remark:

- (1) The amplitude of spurious emissions which are attenuated by more than 20 dB below the permissible value has no need to be reported.
- (2) Distance extrapolation factor = $40 \log (\text{specific distance} / \text{test distance})$ (dB).
- (3) Limit line = specific limits (dBuV) + distance extrapolation factor.

4.2.8 TEST RESULTS (BETWEEN 30MHZ TO 1000 MHZ)

Please refer to the Attachment C.

Remark:

- (1) All readings are Peak unless otherwise stated QP in column of 『Note 』 . Peak denotes that the Peak reading compliance with the QP Limits and then QP Mode measurement didn't perform.
- (2) Measuring frequency range from 30MHz to 1000MHz.
- (3) If the peak scan value lower limit more than 20dB, then this signal data does not show in table.

4.2.9 TEST RESULTS (ABOVE 1000 MHZ)

Please refer to the Attachment D.

Remark:

- (1) All readings are Peak unless otherwise stated QP in column of 『Note 』 . Peak denotes that the Peak reading compliance with the QP Limits and then QP Mode measurement didn't perform.
- (2) Radiated emissions measured in frequency range above 1000MHz were made with an instrument using Peak detector mode and AV detector mode of the emission
- (3) A preamp and high pass filter were used for this test in order to provide sufficient measurement sensitivity.
- (4) EUT Orthogonal Axis:
"X" - denotes Laid on Table ; "Y" - denotes Vertical Stand ; "Z" - denotes Side Stand
- (5) During the measurements above 1 GHz it is taken care of that the EUT is always within the 3 dB cone of radiation BW of the used antenna
- (6) No limit: This is fundamental signal, the judgment is not applicable.
For fundamental signal judgment was referred to Peak output test.

5. BANDWIDTH TEST

5.1 Applied procedures / limit

FCC Part15 (15.247) , Subpart C				
Section	Test Item	Limit	Frequency Range (MHz)	Result
15.247(a)(2)	Bandwidth	$\geq 500\text{KHz}$ (6dB bandwidth)	2400-2483.5	PASS

5.1.1 TEST PROCEDURE

- a. The EUT was directly connected to the spectrum analyzer and antenna output port as show in the block diagram below,
- b. Spectrum Setting : RBW= 100KHz, VBW=300KHz, Sweep time = 2.5 ms.

5.1.2 DEVIATION FROM STANDARD

No deviation.

5.1.3 TEST SETUP



5.1.4 EUT OPERATION CONDITIONS

The EUT tested system was configured as the statements of 4.1.5 Unless otherwise a special operating condition is specified in the follows during the testing.

5.1.5 EUT TEST CONDITIONS

Temperature: 25°C
 Relative Humidity: 55%
 Test Voltage: AC 120V/60Hz

5.1.6 TEST RESULTS

Please refer to the Attachment E.

6. MAXIMUM OUTPUT POWER TEST

6.1 Applied procedures / limit

FCC Part15 (15.247) , Subpart C				
Section	Test Item	Limit	Frequency Range (MHz)	Result
15.247(b)(3)	Maximum Output Power	1 watt or 30dBm	2400-2483.5	PASS

6.1.1 TEST PROCEDURE

- a. The EUT was directly connected to the power meter and antenna output port as show in the block diagram below,
- b. The maximum peak conducted output power was performed in accordance with method 9.1.2 of FCC KDB 558074 D01 DTS Meas Guidance v03r02.

6.1.2 DEVIATION FROM STANDARD

No deviation.

6.1.3 TEST SETUP

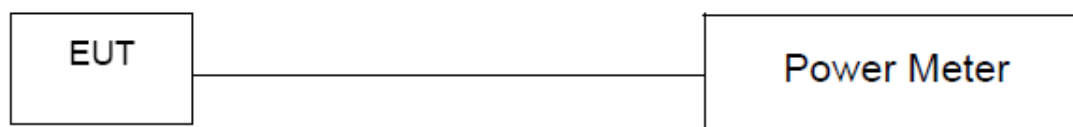

6.1.4 EUT OPERATION CONDITIONS

The EUT tested system was configured as the statements of 4.1.5 Unless otherwise a special operating condition is specified in the follows during the testing. Transmit output power was measured while the host equipment supply voltage was varied from 85 % to 115 % of the nominal rated supply voltage. No change in transmit output power was observed.

6.1.5 EUT TEST CONDITIONS

Temperature: 25°C
 Relative Humidity: 55%
 Test Voltage: AC 120V/60Hz

6.1.6 TEST RESULTS

Please refer to the Attachment F.

7. ANTENNA CONDUCTED SPURIOUS EMISSION

7.1 Applied procedures / limit

In any 100 kHz bandwidth outside the frequency band in which the spread spectrum or digitally modulated device is operating, the RF power that is produced shall be at least 20 dB below that in the 100 kHz bandwidth within the band that contains the highest level of the desired power, based on either an RF conducted or a radiated measurement, provided that transmitter demonstrates compliance with the peak conducted power limits.

7.1.1 TEST PROCEDURE

- a. The EUT was directly connected to the spectrum analyzer and antenna output port as show in the block diagram below,
- b. Spectrum Setting : RBW= 100KHz, VBW=300KHz, Sweep time = 10 ms.
- c. Offset=antenna gain+ cable loss

7.1.2 DEVIATION FROM STANDARD

No deviation.

7.1.3 TEST SETUP



7.1.4 EUT OPERATION CONDITIONS

The EUT tested system was configured as the statements of 4.1.5 Unless otherwise a special operating condition is specified in the follows during the testing.

7.1.5 EUT OPERATION CONDITIONS

Temperature: 25°C
 Relative Humidity: 55%
 Test Voltage: AC 120V/60Hz

7.1.6 TEST RESULTS

Please refer to the Attachment G.

8. POWER SPECTRAL DENSITY TEST

8.1 Applied procedures / limit

FCC Part15 (15.247) , Subpart C				
Section	Test Item	Limit	Frequency Range (MHz)	Result
15.247(e)	Power Spectral Density	8 dBm (in any 3KHz)	2400-2483.5	PASS

8.1.1 TEST PROCEDURE

- a. The EUT was directly connected to the spectrum analyzer and antenna output port as show in the block diagram below,
- b. Spectrum Setting: RBW=3KHz, VBW=10 KHz, Sweep time = auto.

8.1.2 DEVIATION FROM STANDARD

No deviation.

8.1.3 TEST SETUP

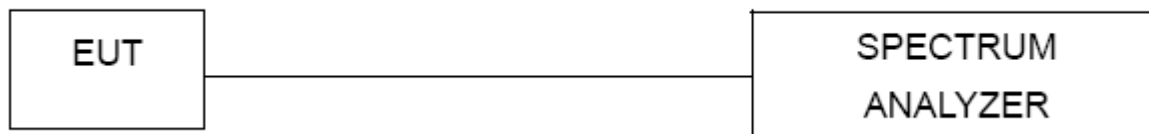

8.1.4 EUT OPERATION CONDITIONS

The EUT tested system was configured as the statements of 4.1.5 Unless otherwise a special operating condition is specified in the follows during the testing.

8.1.5 EUT TEST CONDITIONS

Temperature: 25°C
 Relative Humidity: 55%
 Test Voltage: AC 120V/60Hz

8.1.6 TEST RESULTS

Please refer to the Attachment H.

9. MEASUREMENT INSTRUMENTS LIST

Conducted Emission Measurement					
Item	Kind of Equipment	Manufacturer	Type No.	Serial No.	Calibrated until
1	LISN	R&S	ENV216	101050	Nov. 24, 2015
2	Test Cable	TIMES	CFD300-NL	C01	Jun. 16, 2016
3	EMI Test Receiver	R&S	ESCI	100082	Apr. 14, 2016
4	Measurement Software	EZ	EZ EMC (Version NB-02A)	N/A	N/A

Radiated Emission Measurement					
Item	Kind of Equipment	Manufacturer	Type No.	Serial No.	Calibrated until
1	Spectrum Analyzer	R&S	FSP-40	100129	Jan. 07, 2016
2	Horn Antenna	Schwarzbeck	BBHA 9120	D-325	Jun. 15, 2016
3	Microwave Pre_amplifier	Agilent	8449B	3008A01714	Apr. 16, 2016
4	Microflex Cable	Harbour industries	27478LL142	1m	May 13, 2016
5	Microflex Cable	EMC	S104-SMA	8m	May 15, 2016
6	Microflex Cable	Harbour industries	27478LL142	3m	May 13, 2016
7	Test Cable	LMR	LMR-400	12m	May 14, 2016
8	Test Cable	LMR	LMR-400	3m	May 14, 2016
9	Pre-Amplifier	Anritsu	MH648A	M92649	Jun. 18, 2016
10	Log-Bicon Antenna	Schwarzbeck	VULB9168-352	9168-352	July. 11, 2016
11	Loop Antenna	EMCO	6502	00042960	Nov. 07, 2016

6dB Bandwidth Measurement					
Item	Kind of Equipment	Manufacturer	Type No.	Serial No.	Calibrated until
1	Spectrum Analyzer	R&S	FSP-40	100129	Jan. 07, 2016

Peak Output Power Measurement					
Item	Kind of Equipment	Manufacturer	Type No.	Serial No.	Calibrated until
1	Spectrum Analyzer	R&S	FSP-40	100129	Jan. 07, 2016

Antenna Conducted Spurious Emission Measurement

Item	Kind of Equipment	Manufacturer	Type No.	Serial No.	Calibrated until
1	Spectrum Analyzer	R&S	FSP-40	100129	Jan. 07, 2016

Power Spectral Density Measurement

Item	Kind of Equipment	Manufacturer	Type No.	Serial No.	Calibrated until
1	Spectrum Analyzer	R&S	FSP-40	100129	Jan. 07, 2016

Remark: "N/A" denotes no model name, serial no. or calibration specified.
 All calibration period of equipment list is one year.

10. EUT TEST PHOTO**Conducted Measurement Photos**

Radiated Measurement Photos

9K-30MHz

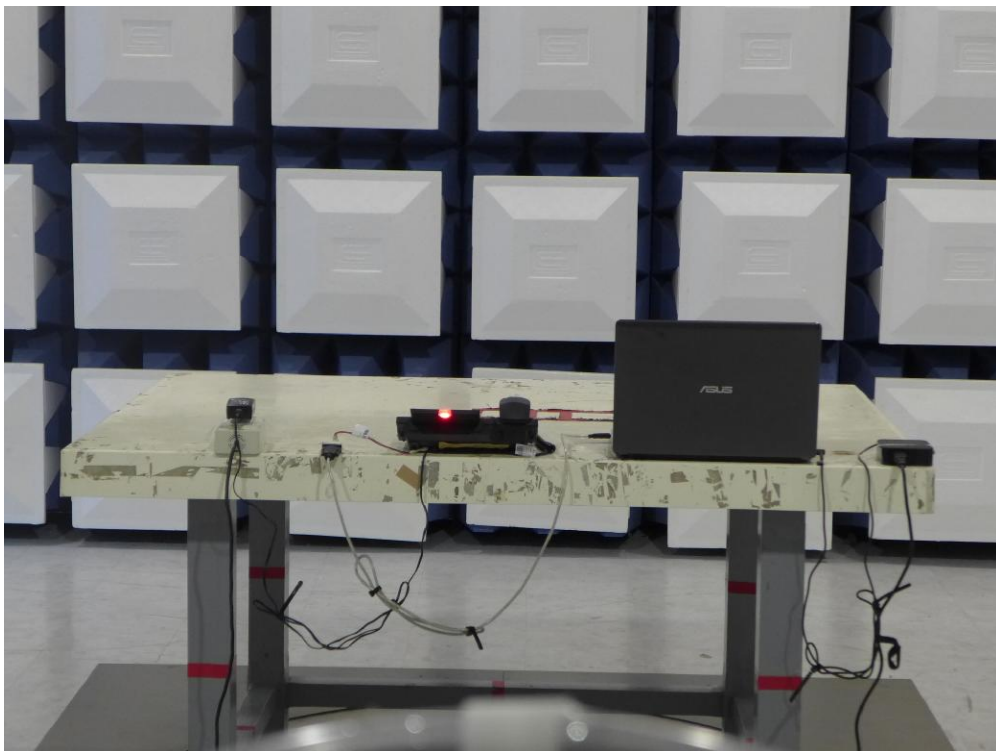
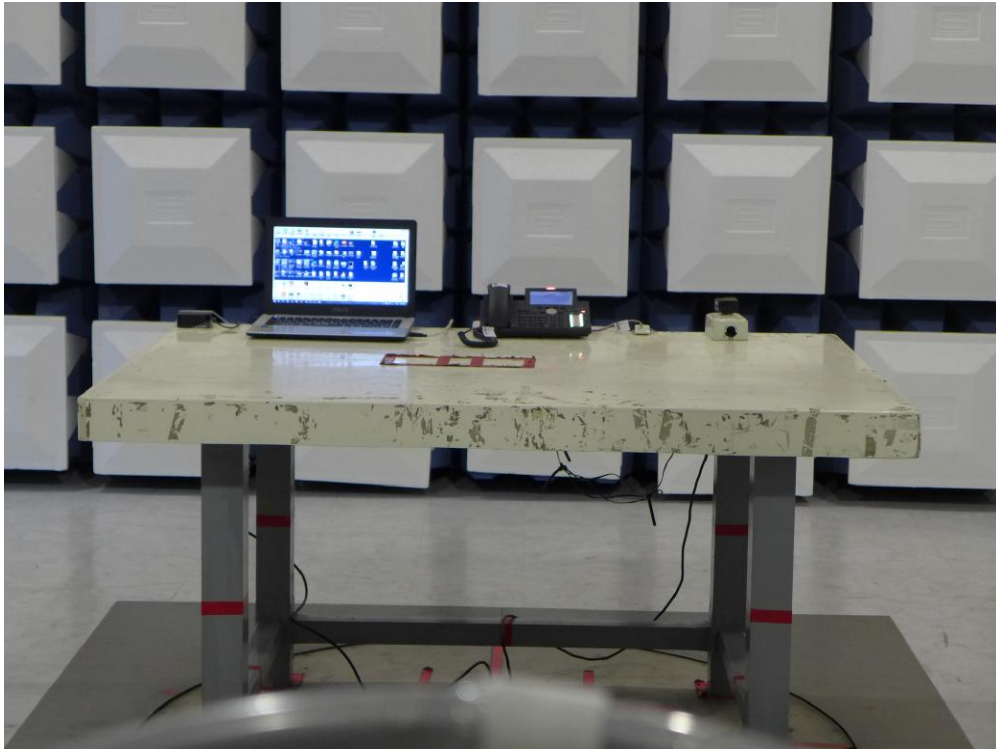

Radiated Measurement Photos

30MHz-1G

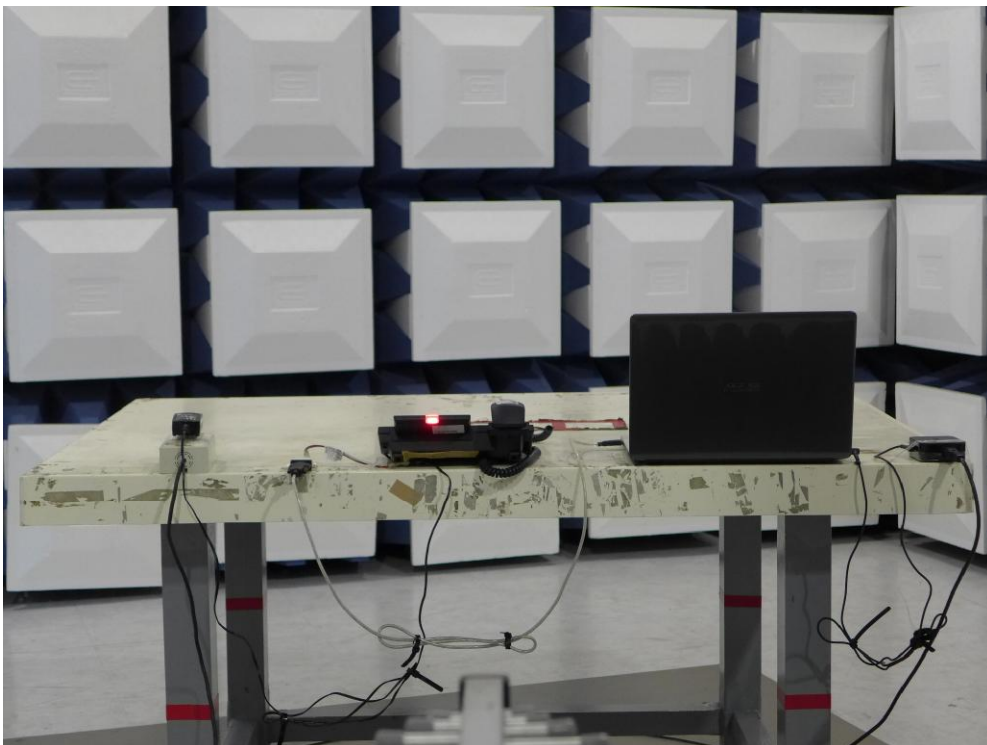
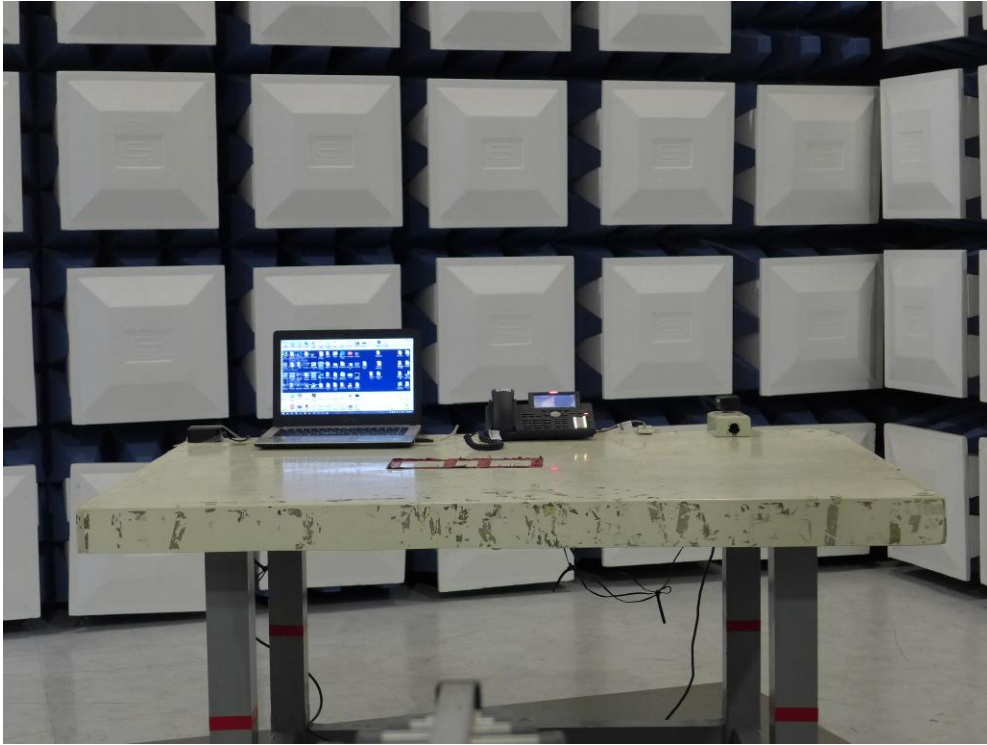

Radiated Measurement Photos

Above 1G

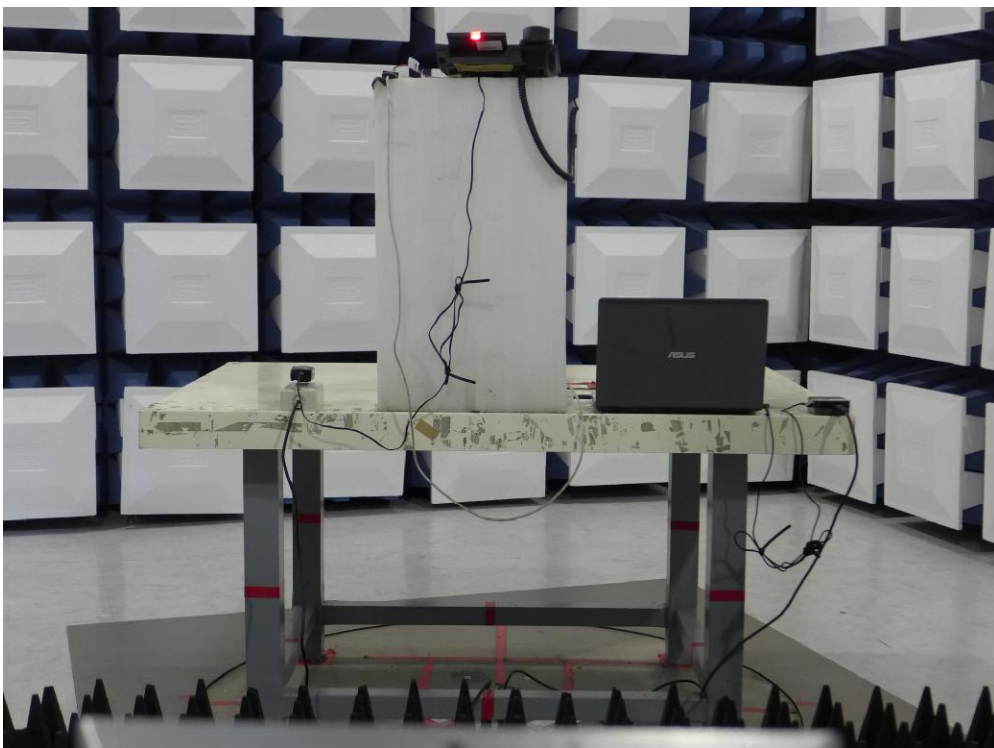
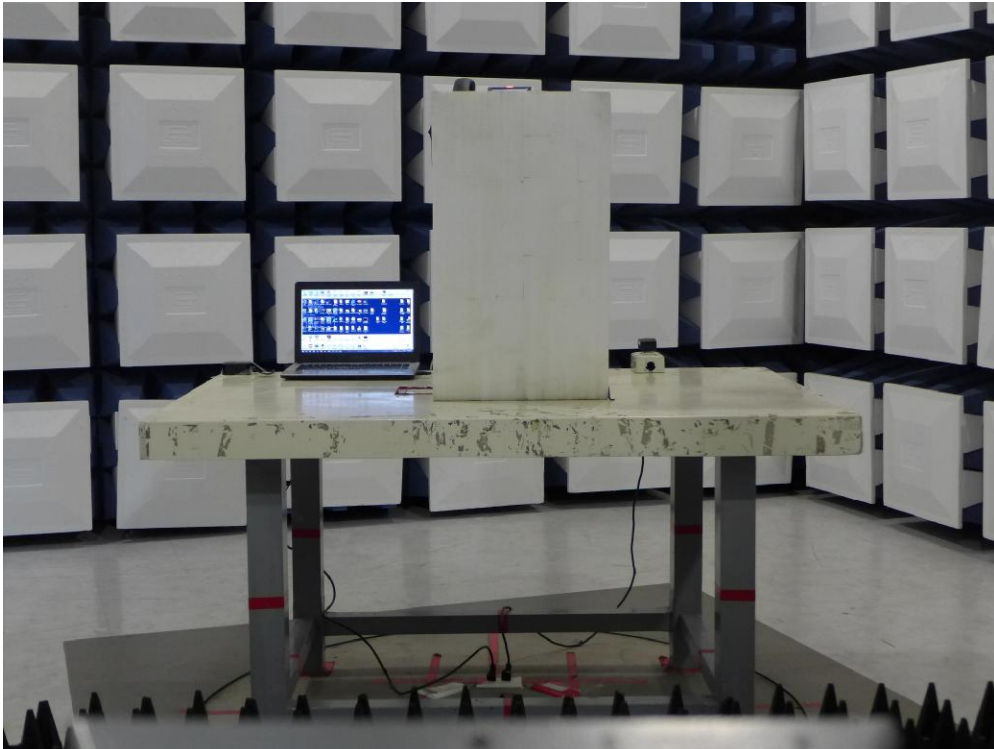

ATTACHMENT A - CONDUCTED EMISSION

Test Mode: Bluetooth

Line

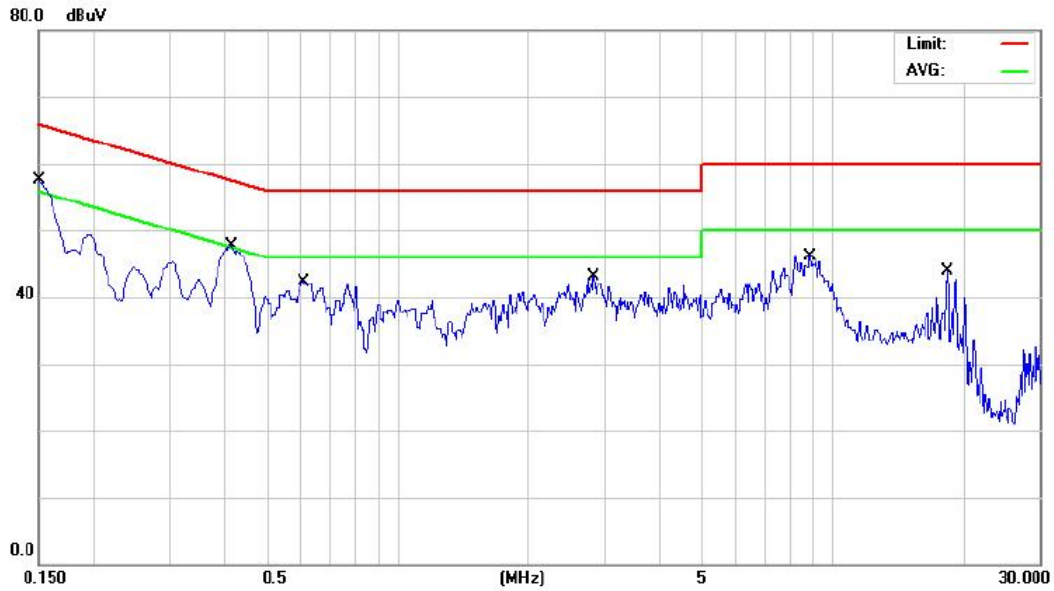

No. Mk.	Freq. MHz	Reading Level dBuV	Correct Factor dB	Measure- ment dBuV	Limit dBuV	Margin dB	Detector	Comment
1	0.1500	45.60	9.64	55.24	65.99	-10.75	QP	
2 *	0.1500	38.10	9.64	47.74	55.99	-8.25	AVG	
3	0.4139	32.60	9.63	42.23	57.57	-15.34	QP	
4	0.4139	28.00	9.63	37.63	47.57	-9.94	AVG	
5	0.6080	28.80	9.64	38.44	56.00	-17.56	QP	
6	0.6080	23.90	9.64	33.54	46.00	-12.46	AVG	
7	2.8130	26.10	9.77	35.87	56.00	-20.13	QP	
8	2.8130	19.50	9.77	29.27	46.00	-16.73	AVG	
9	8.8500	30.70	9.90	40.60	60.00	-19.40	QP	
10	8.8500	24.10	9.90	34.00	50.00	-16.00	AVG	
11	18.3000	29.40	9.84	39.24	60.00	-20.76	QP	
12	18.3000	24.20	9.84	34.04	50.00	-15.96	AVG	

Test Mode: Bluetooth

Neutral

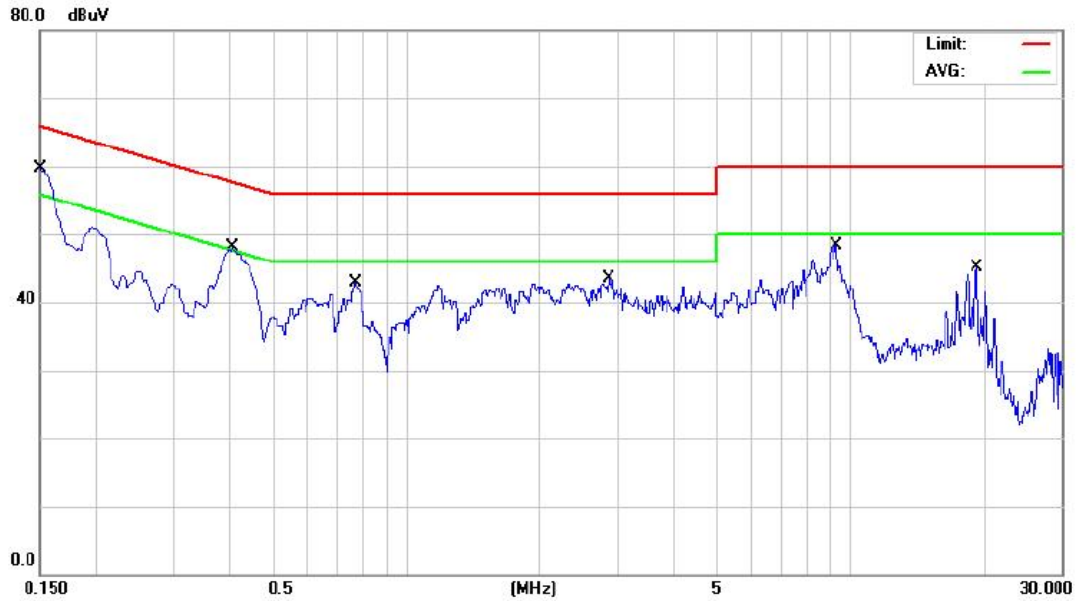

No.	Mk.	Freq. MHz	Reading Level dBuV	Correct Factor dB	Measure- ment dBuV	Limit dBuV	Margin dB	Detector	Comment
1		0.1500	47.50	9.63	57.13	65.99	-8.86	QP	
2	*	0.1500	39.50	9.63	49.13	55.99	-6.86	AVG	
3		0.4069	33.00	9.64	42.64	57.71	-15.07	QP	
4		0.4069	28.10	9.64	37.74	47.71	-9.97	AVG	
5		0.7700	29.10	9.66	38.76	56.00	-17.24	QP	
6		0.7700	24.10	9.66	33.76	46.00	-12.24	AVG	
7		2.8580	27.80	9.76	37.56	56.00	-18.44	QP	
8		2.8580	21.40	9.76	31.16	46.00	-14.84	AVG	
9		9.3000	30.80	9.91	40.71	60.00	-19.29	QP	
10		9.3000	24.50	9.91	34.41	50.00	-15.59	AVG	
11		19.2000	31.40	9.87	41.27	60.00	-18.73	QP	
12		19.2000	26.80	9.87	36.67	50.00	-13.33	AVG	

ATTACHMENT B - RADIATED EMISSION (9KHZ TO 30MHZ)

Test Mode:	TX Mode
------------	---------

Frequency (MHz)	Ant 0°/90°	Read level dBuV/m	Factor (dB)	Measured(FS) (dBuV/m)	Limit (dBuV/m)	Margin (dB)	Note
0.0153	0°	32.53	22.27	54.80	103.91	-49.11	AVG
0.0153	0°	42.54	22.27	64.81	123.91	-59.10	PK
0.0266	0°	29.45	21.99	51.44	99.11	-47.67	AVG
0.0266	0°	35.35	21.99	57.34	119.11	-61.77	PK
0.0427	0°	26.43	21.58	48.01	95.00	-46.98	AVG
0.0427	0°	31.35	21.58	52.93	115.00	-62.06	PK
0.0620	0°	35.35	21.21	56.56	111.76	-55.20	PK
1.2490	0°	33.59	20.35	53.94	65.67	-11.73	QP
1.5300	0°	35.64	20.07	55.71	63.91	-8.20	QP

Frequency (MHz)	Ant 0°/90°	Read level dBuV/m	Factor (dB)	Measured(FS) (dBuV/m)	Limit (dBuV/m)	Margin (dB)	Note
0.0174	90°	32.57	22.22	54.79	102.79	-48.01	AVG
0.0174	90°	43.41	22.22	65.63	122.79	-57.17	PK
0.0250	90°	28.50	22.03	50.53	99.65	-49.12	AVG
0.0250	90°	34.65	22.03	56.68	119.65	-62.97	PK
0.0463	90°	27.69	21.49	49.18	94.29	-45.11	AVG
0.0463	90°	32.41	21.49	53.90	114.29	-60.39	PK
0.0750	90°	35.63	21.00	56.63	110.10	-53.47	PK
1.4250	90°	32.51	20.18	52.69	64.53	-11.84	QP
1.7490	90°	34.92	19.85	54.77	69.54	-14.77	QP

Remark:

- (1) The amplitude of spurious emissions which are attenuated by more than 20 dB below the permissible value has no need to be reported.
- (2) Distance extrapolation factor = $40 \log(\text{specific distance} / \text{test distance})$ (dB);
- (3) Limit line = specific limits (dBuV) + distance extrapolation factor.

ATTACHMENT C - RADIATED EMISSION (30MHZ TO 1000MHZ)

Test Mode: TX 2440MHz -CH19 -1Mbps

Vertical

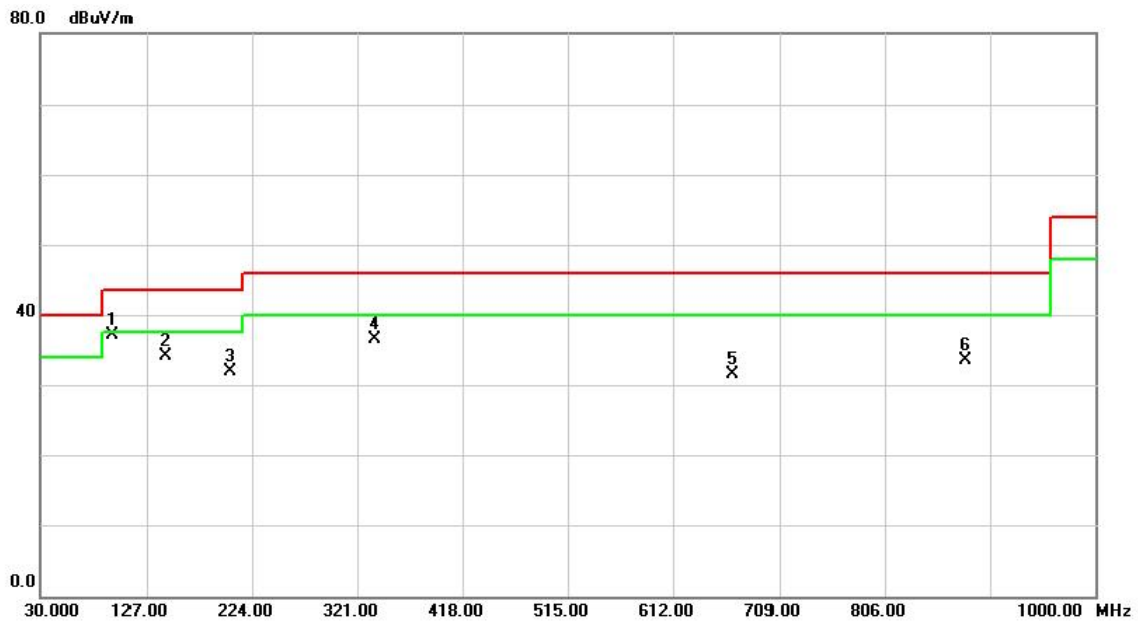

No.	Mk.	Freq. MHz	Reading Level dBuV	Correct Factor dB	Measure- ment dBuV/m	Limit dBuV/m	Margin dB	Detector	Comment
1	*	95.9600	54.64	-17.61	37.03	43.50	-6.47	peak	
2		144.4600	48.36	-14.34	34.02	43.50	-9.48	peak	
3		203.6300	47.03	-15.09	31.94	43.50	-11.56	peak	
4		336.5200	47.07	-10.65	36.42	46.00	-9.58	peak	
5		666.3200	36.69	-5.21	31.48	46.00	-14.52	peak	
6		880.6900	35.43	-1.89	33.54	46.00	-12.46	peak	

Test Mode: TX 2440MHz -CH19 -1Mbps

Horizontal

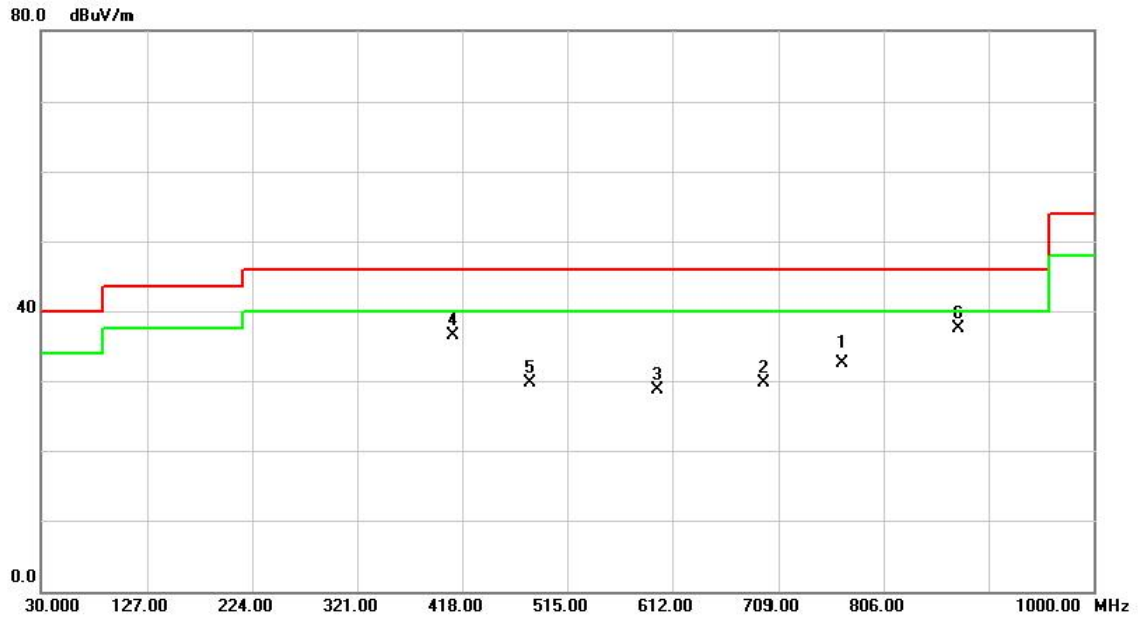

No.	Mk.	Freq. MHz	Reading Level dBuV	Correct Factor dB	Measure- ment dBuV/m	Limit dBuV/m	Margin dB	Detector	Comment
1		768.1700	36.05	-3.46	32.59	46.00	-13.41	peak	
2		696.3900	34.37	-4.58	29.79	46.00	-16.21	peak	
3		598.4200	35.44	-6.68	28.76	46.00	-17.24	peak	
4		409.2700	46.10	-9.61	36.49	46.00	-9.51	peak	
5		480.0800	38.14	-8.53	29.61	46.00	-16.39	peak	
6	*	874.8700	39.59	-2.01	37.58	46.00	-8.42	peak	

ATTACHMENT D - RADIATED EMISSION (ABOVE 1000MHZ)

Orthogonal Axis :	X
Test Mode :	TX 2402MHz _CH00_1Mbps

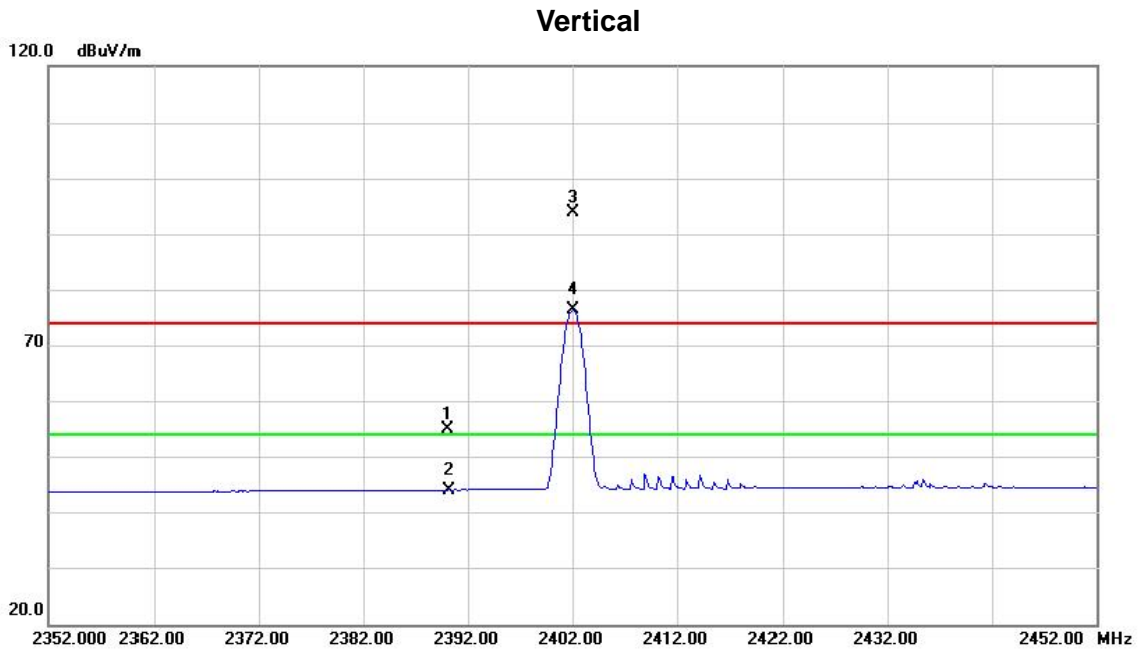

No.	Mk.	Freq. MHz	Reading Level dBuV	Correct Factor dB	Measure- ment dBuV/m	Limit dBuV/m	Margin dB	Detector	Comment
1		2390.000	24.25	30.56	54.81	74.00	-19.19	peak	
2		2390.000	13.41	30.56	43.97	54.00	-10.03	AVG	
3	X	2402.000	63.32	30.61	93.93	74.00	19.93	peak	NO LIMIT
4	*	2402.000	45.70	30.61	76.31	54.00	22.31	AVG	NO LIMIT

Orthogonal Axis :	X
Test Mode :	TX 2402MHz _CH00_1Mbps

Vertical

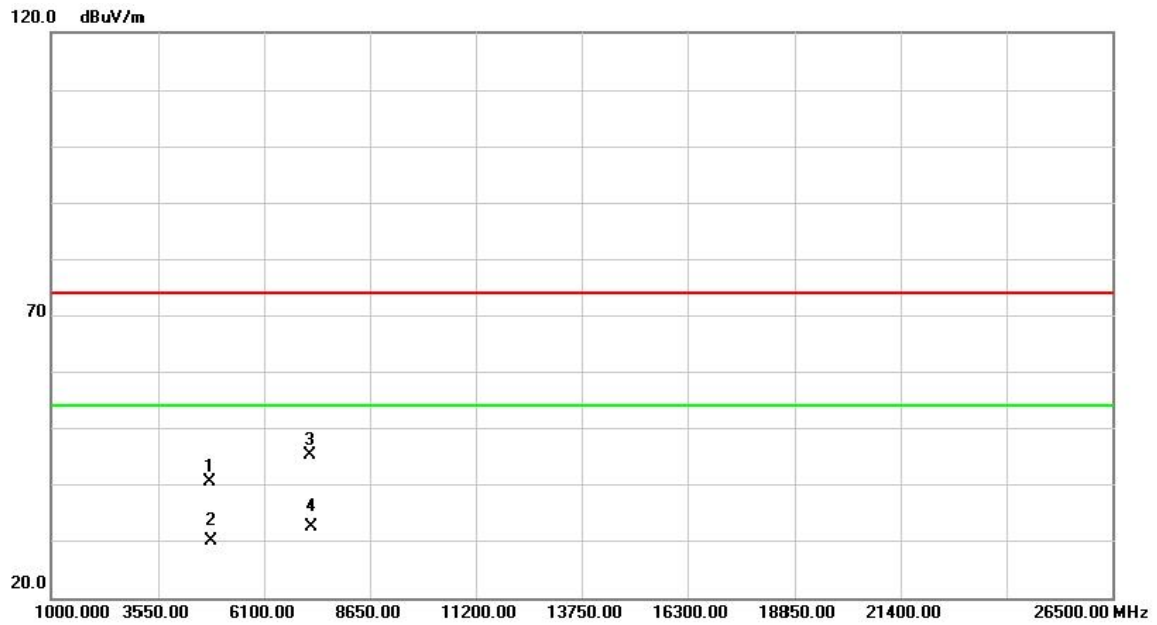

No.	Mk.	Freq. MHz	Reading Level dBuV	Correct Factor dB	Measure- ment dBuV/m	Limit dBuV/m	Margin dB	Detector	Comment
1		4804.080	37.21	3.24	40.45	74.00	-33.55	peak	
2		4804.080	26.58	3.24	29.82	54.00	-24.18	AVG	
3		7205.840	36.79	8.41	45.20	74.00	-28.80	peak	
4	*	7205.840	23.89	8.41	32.30	54.00	-21.70	AVG	

Orthogonal Axis :	X
Test Mode :	TX 2402MHz _CH00_1Mbps

Horizontal

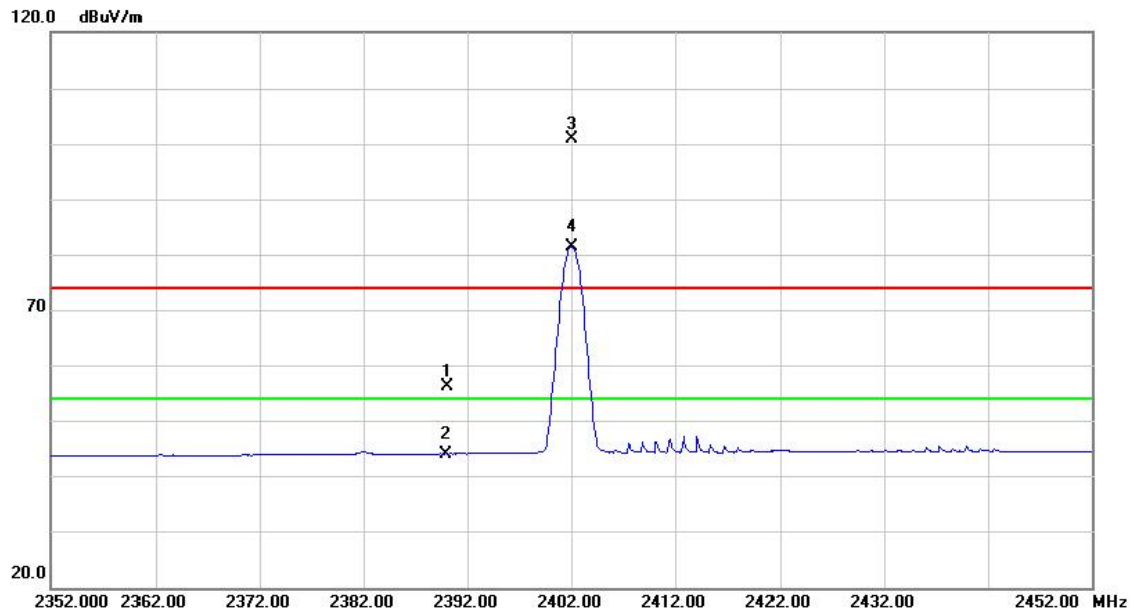

No.	Mk.	Freq. MHz	Reading Level dBuV	Correct Factor dB	Measure- ment dBuV/m	Limit dBuV/m	Margin dB	Detector	Comment
1		2390.000	25.69	30.56	56.25	74.00	-17.75	peak	
2		2390.000	13.40	30.56	43.96	54.00	-10.04	AVG	
3	X	2402.000	70.26	30.61	100.87	74.00	26.87	peak	NO LIMIT
4	*	2402.000	50.72	30.61	81.33	54.00	27.33	AVG	NO LIMIT

Orthogonal Axis :	X
Test Mode :	TX 2402MHz _CH00_1Mbps

Horizontal

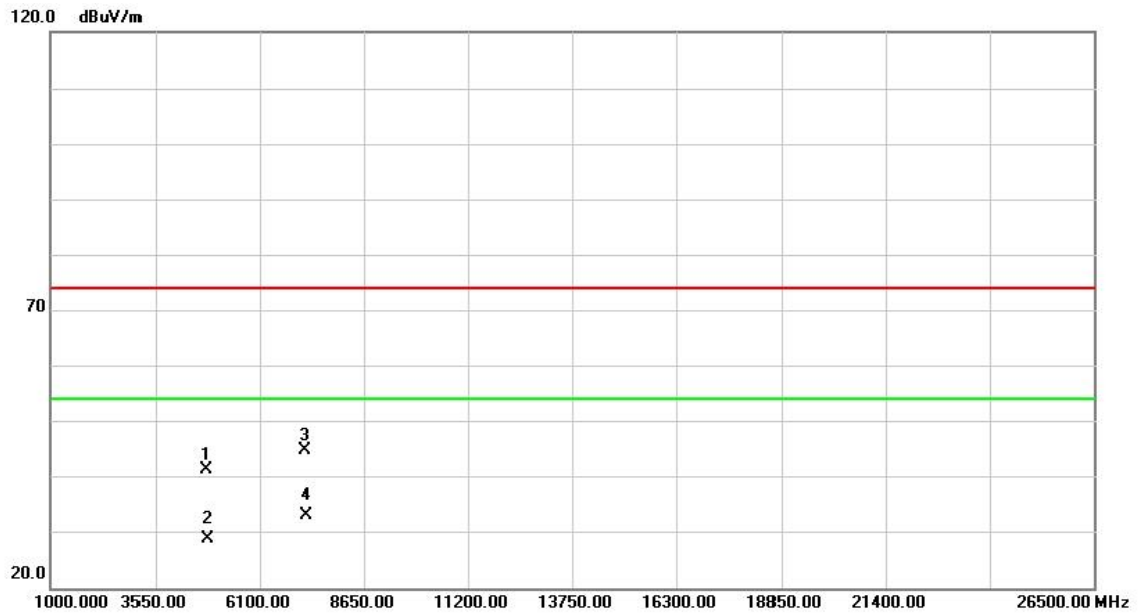

No.	Mk.	Freq. MHz	Reading Level dBuV	Correct Factor dB	Measure- ment dBuV/m	Limit dBuV/m	Margin dB	Detector	Comment
1		4803.765	37.83	3.24	41.07	74.00	-32.93	peak	
2		4803.765	25.31	3.24	28.55	54.00	-25.45	AVG	
3		7206.280	36.25	8.41	44.66	74.00	-29.34	peak	
4	*	7206.280	24.58	8.41	32.99	54.00	-21.01	AVG	

Orthogonal Axis :	X
Test Mode :	TX 2440MHz _CH19_1Mbps

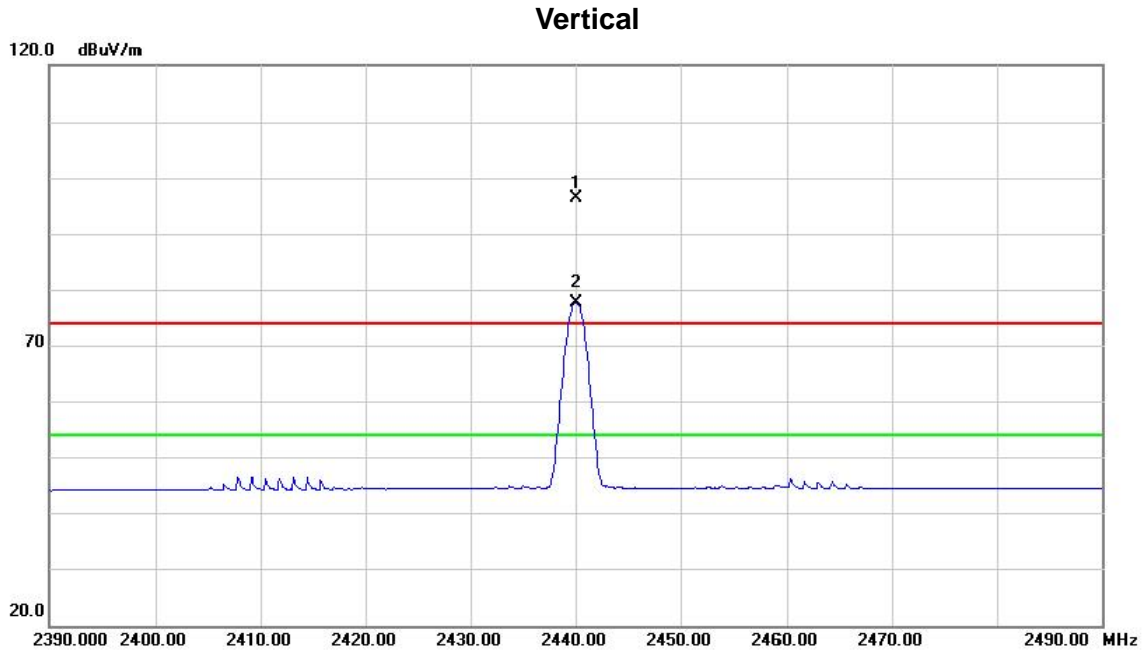

No.	Mk.	Freq. MHz	Reading Level dBuV	Correct Factor dB	Measure- ment dBuV/m	Limit dBuV/m	Margin dB	Detector	Comment
1	X	2440.000	65.78	30.72	96.50	74.00	22.50	peak	NO LIMIT
2	*	2440.000	46.91	30.72	77.63	54.00	23.63	AVG	NO LIMIT

Orthogonal Axis :	X
Test Mode :	TX 2440MHz _CH19_1Mbps

Vertical

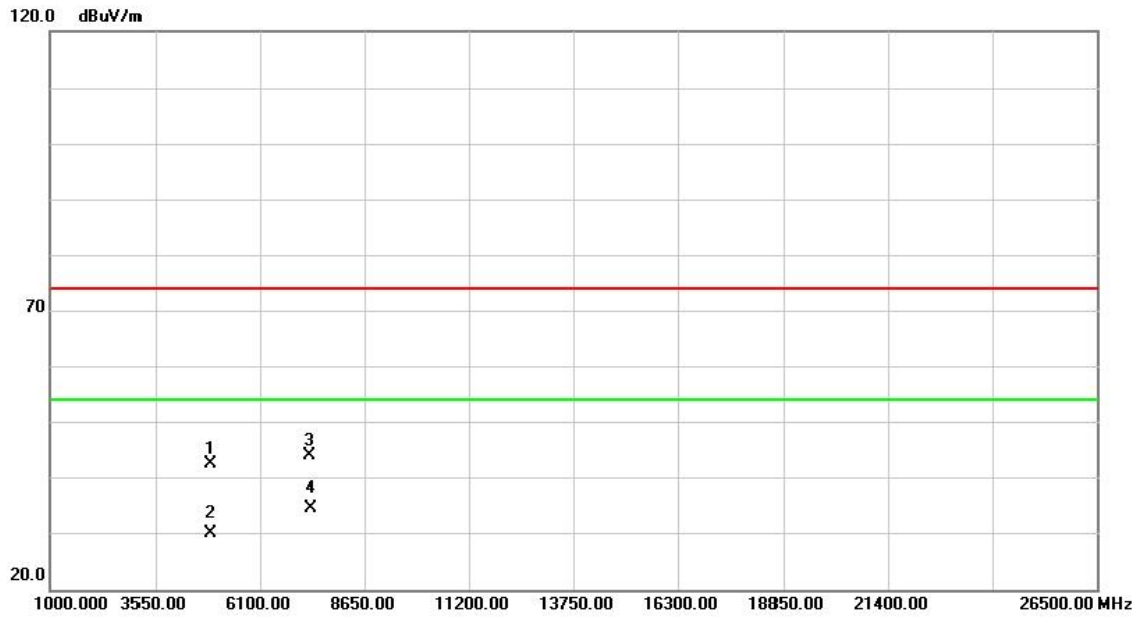

No.	Mk.	Freq. MHz	Reading Level dBuV	Correct Factor dB	Measure- ment dBuV/m	Limit dBuV/m	Margin dB	Detector	Comment
1		4880.070	38.77	3.52	42.29	74.00	-31.71	peak	
2		4880.070	26.44	3.52	29.96	54.00	-24.04	AVG	
3		7320.350	35.25	8.62	43.87	74.00	-30.13	peak	
4	*	7320.350	25.78	8.62	34.40	54.00	-19.60	AVG	

Orthogonal Axis :	X
Test Mode :	TX 2440MHz _CH19_1Mbps

Horizontal

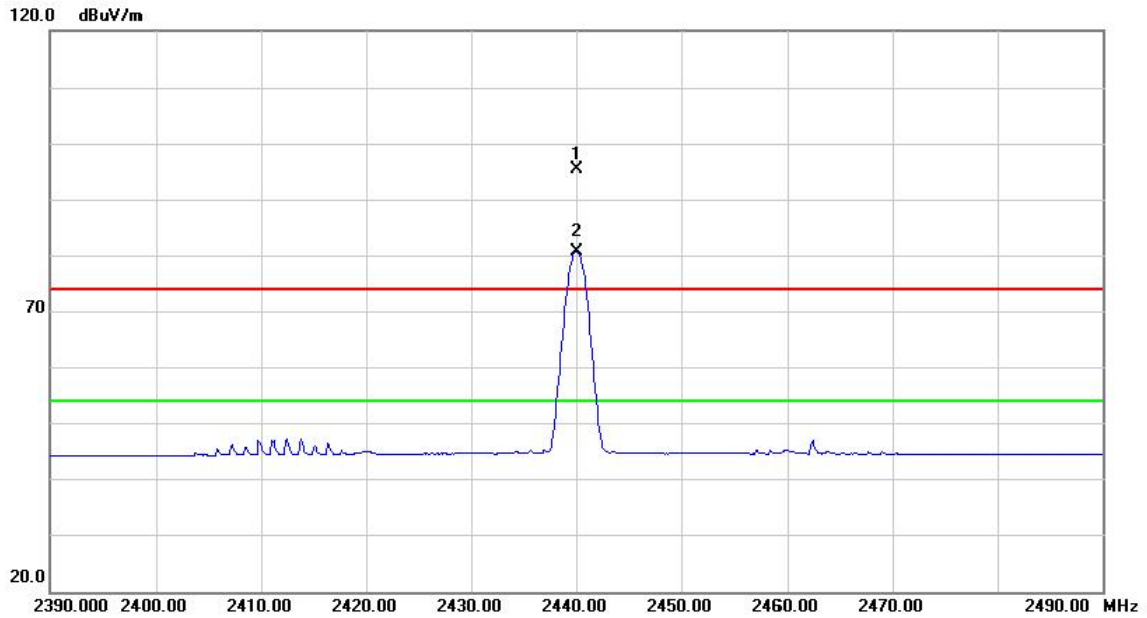

No.	Mk.	Freq.	Reading Level	Correct Factor	Measurement	Limit	Margin	Detector	Comment
		MHz	dBuV	dB	dBuV/m	dBuV/m	dB		
1	X	2440.000	64.57	30.72	95.29	74.00	21.29	peak	NO LIMIT
2	*	2440.000	49.87	30.72	80.59	54.00	26.59	AVG	NO LIMIT

Orthogonal Axis :	X
Test Mode :	TX 2440MHz _CH19_1Mbps

Horizontal

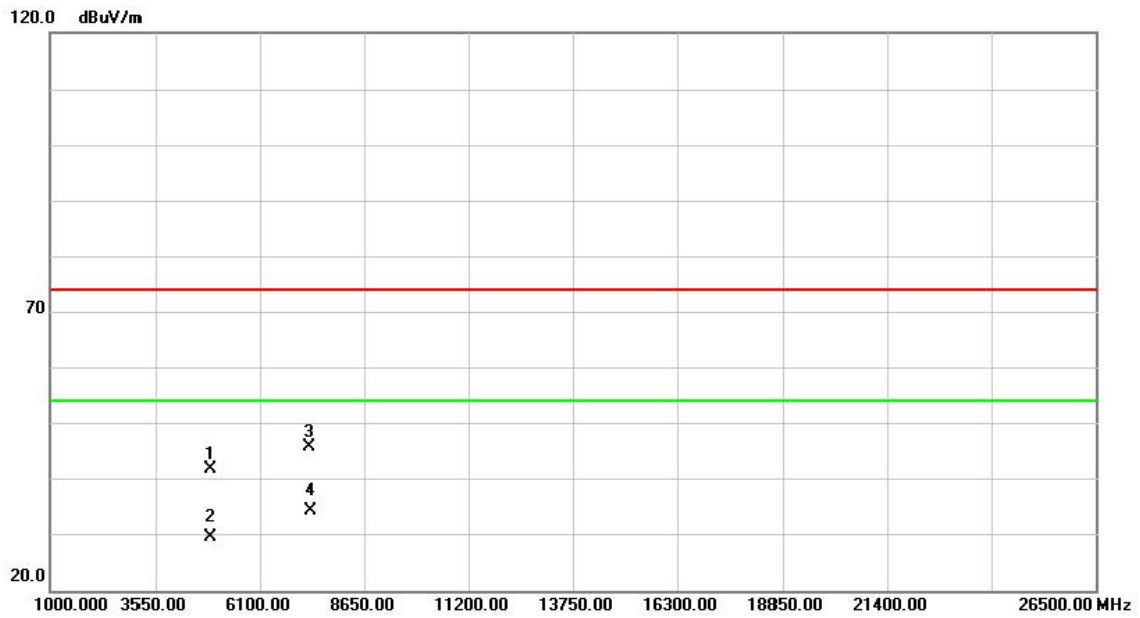

No.	Mk.	Freq. MHz	Reading Level dBuV	Correct Factor dB	Measure- ment dBuV/m	Limit dBuV/m	Margin dB	Detector	Comment
1		4880.365	38.19	3.52	41.71	74.00	-32.29	peak	
2		4880.365	25.85	3.52	29.37	54.00	-24.63	AVG	
3		7321.065	37.06	8.62	45.68	74.00	-28.32	peak	
4	*	7321.065	25.48	8.62	34.10	54.00	-19.90	AVG	

Orthogonal Axis :	X
Test Mode :	TX 2480MHz _CH39_1Mbps

Vertical

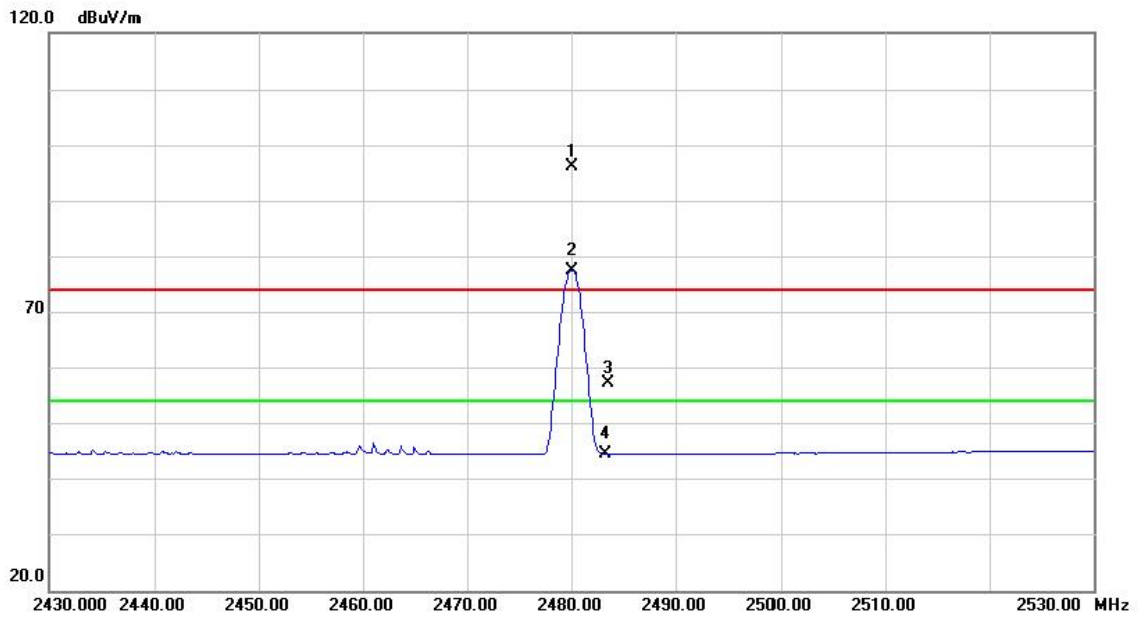

No.	Mk.	Freq. MHz	Reading Level dBuV	Correct Factor dB	Measure- ment dBuV/m	Limit dBuV/m	Margin dB	Detector	Comment
1	X	2480.000	65.25	30.86	96.11	74.00	22.11	peak	NO LIMIT
2	*	2480.000	46.61	30.86	77.47	54.00	23.47	AVG	NO LIMIT
3		2483.500	26.35	30.87	57.22	74.00	-16.78	peak	
4		2483.500	13.50	30.87	44.37	54.00	-9.63	AVG	

Orthogonal Axis :	X
Test Mode :	TX 2480MHz _CH39_1Mbps

Vertical

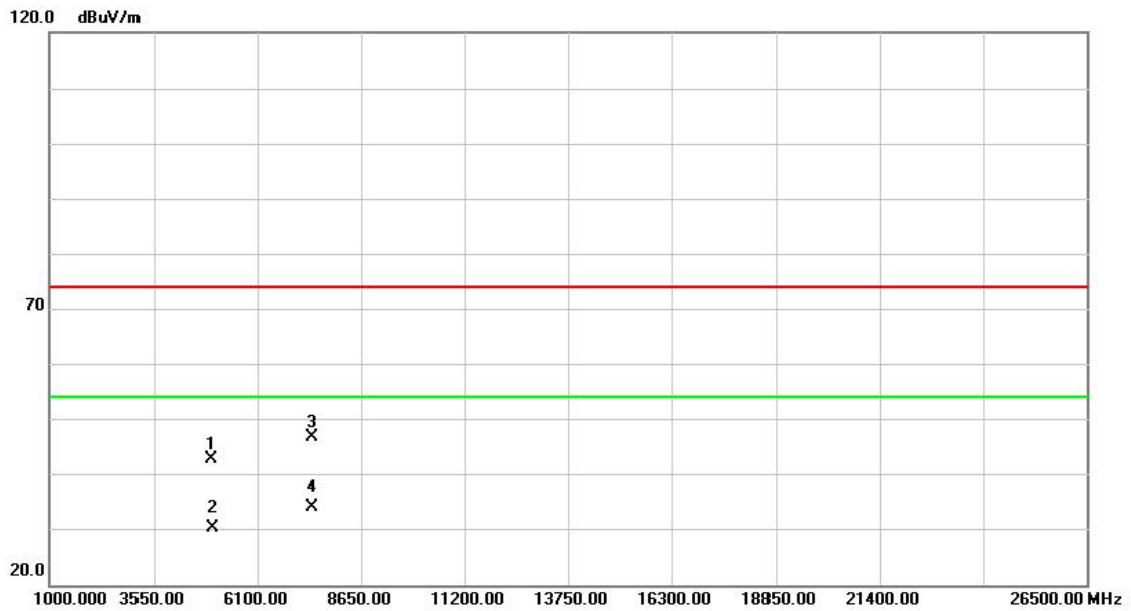

No.	Mk.	Freq. MHz	Reading Level dBuV	Correct Factor dB	Measure- ment dBuV/m	Limit dBuV/m	Margin dB	Detector	Comment
1		4959.880	38.69	3.82	42.51	74.00	-31.49	peak	
2		4959.880	26.42	3.82	30.24	54.00	-23.76	AVG	
3		7439.805	37.82	8.86	46.68	74.00	-27.32	peak	
4	*	7439.805	25.14	8.86	34.00	54.00	-20.00	AVG	

Orthogonal Axis :	X
Test Mode :	TX 2480MHz _CH39_1Mbps

Horizontal

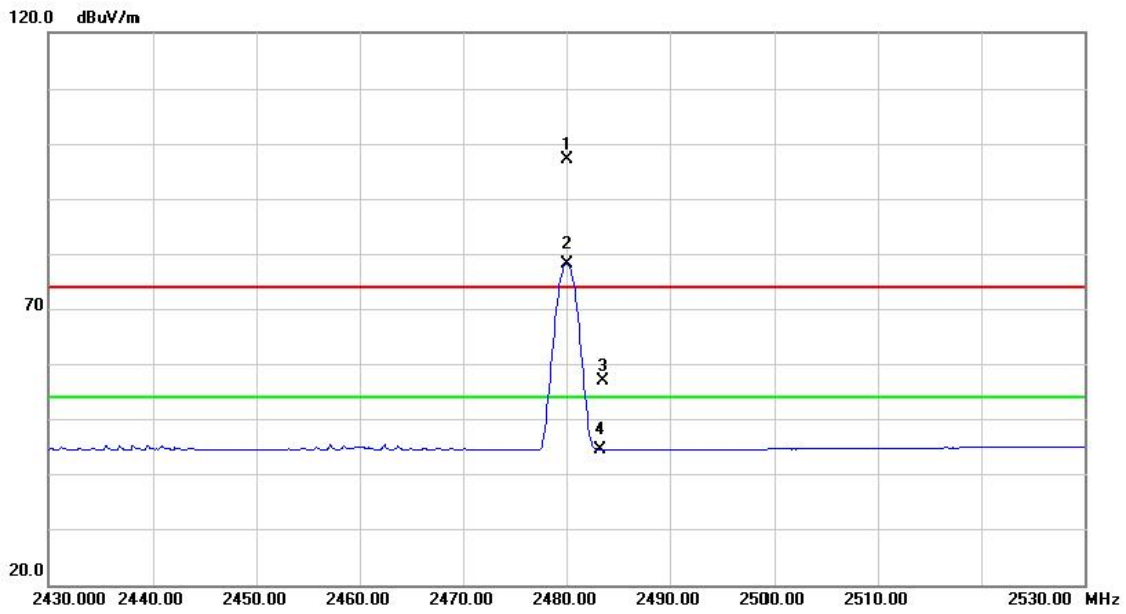

No.	Mk.	Freq. MHz	Reading Level dBuV	Correct Factor dB	Measure- ment dBuV/m	Limit dBuV/m	Margin dB	Detector	Comment
1	X	2480.000	66.25	30.86	97.11	74.00	23.11	peak	NO LIMIT
2	*	2480.000	47.30	30.86	78.16	54.00	24.16	AVG	NO LIMIT
3		2483.500	25.89	30.87	56.76	74.00	-17.24	peak	
4		2483.500	13.53	30.87	44.40	54.00	-9.60	AVG	

Orthogonal Axis :	X
Test Mode :	TX 2480MHz _CH39_1Mbps

Horizontal

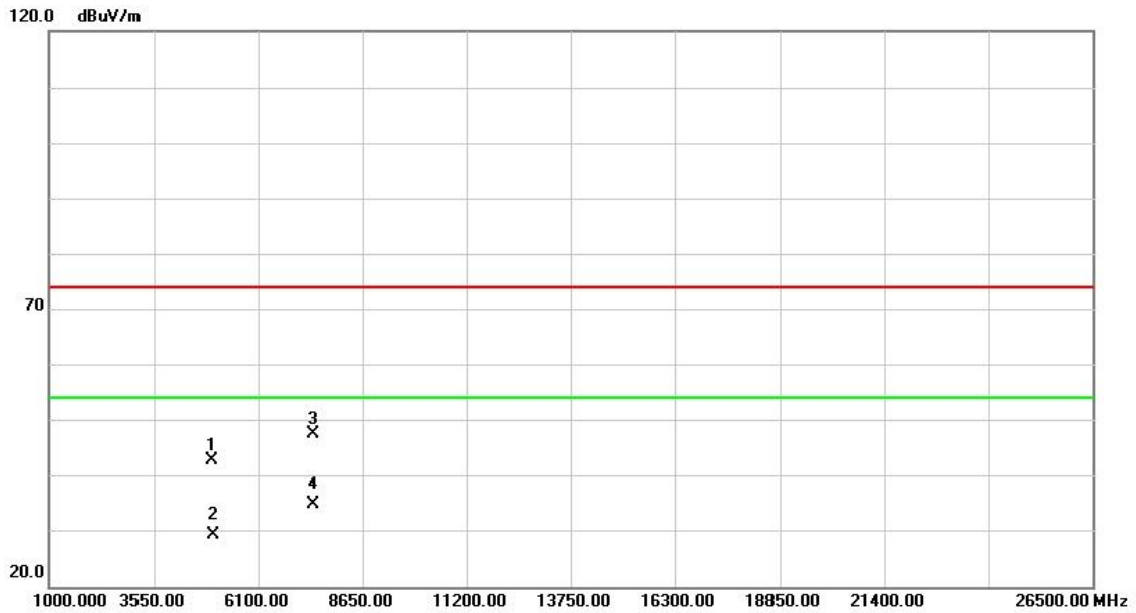

No.	Mk.	Freq. MHz	Reading Level dBuV	Correct Factor dB	Measure- ment dBuV/m	Limit dBuV/m	Margin dB	Detector	Comment
1		4959.980	38.74	3.82	42.56	74.00	-31.44	peak	
2		4959.980	25.33	3.82	29.15	54.00	-24.85	AVG	
3		7439.995	38.48	8.85	47.33	74.00	-26.67	peak	
4	*	7439.995	25.75	8.85	34.60	54.00	-19.40	AVG	

ATTACHMENT E - BANDWIDTH

Frequency (MHz)	6dB Bandwidth (MHz)	99% Occupied BW (MHz)	Min. Limit (kHz)	Test Result
2402	0.710	1.060	500	Complies
2440	0.716	1.064	500	Complies
2480	0.720	1.068	500	Complies

TX CH00

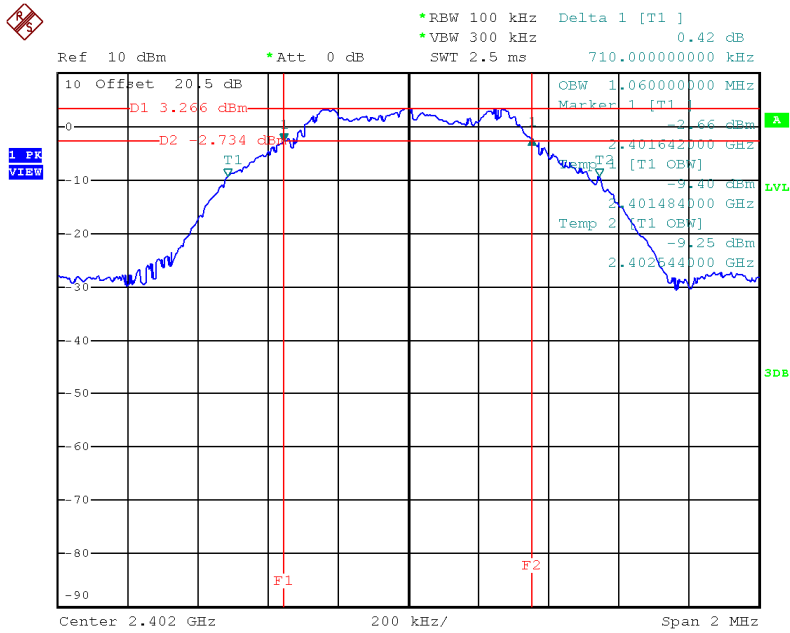

Date: 24.AUG.2015 15:03:48

TX CH19

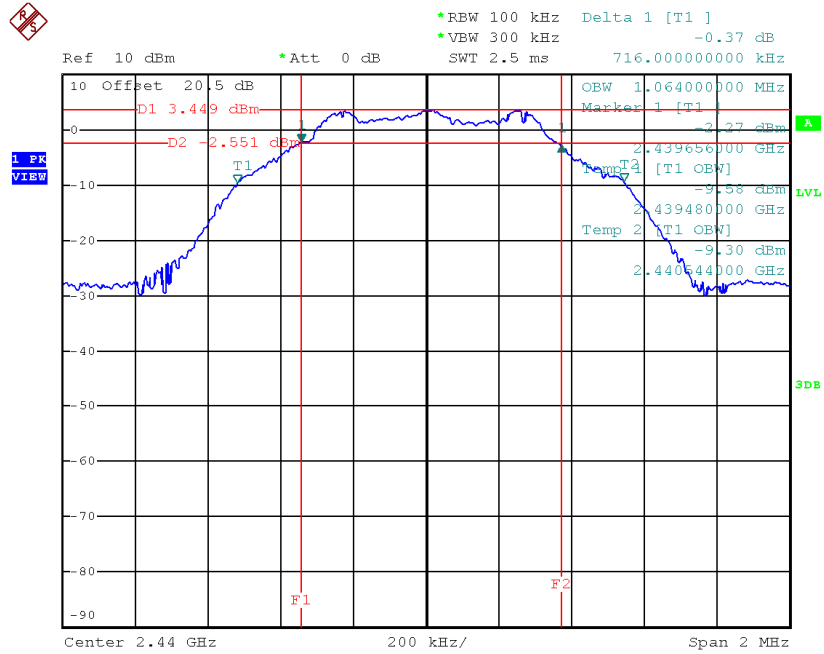

Date: 24.AUG.2015 15:05:35

TX CH39

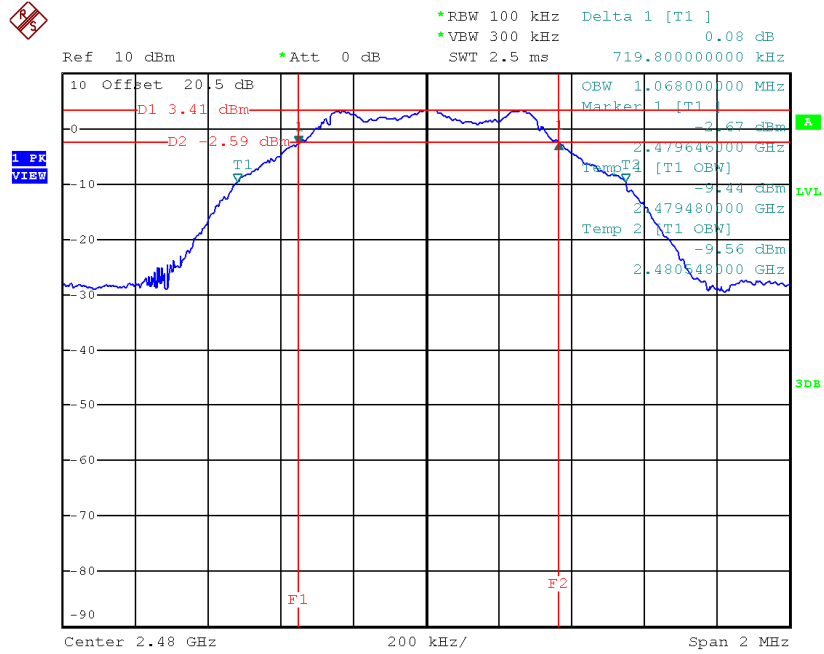

Date: 24.AUG.2015 15:11:11

ATTACHMENT F - MAXIMUM OUTPUT POWER TEST

Frequency (MHz)	Conducted Power (dBm)	Conducted Power (Watt)	Max. Limit (dBm)	Max. Limit (Watt)	Test Result
2402	5.36	0.0034	30.00	1.00	Complies
2440	6.92	0.0049	30.00	1.00	Complies
2480	6.98	0.0050	30.00	1.00	Complies

**ATTACHMENT G - ANTENNA CONDUCTED SPURIOUS
EMISSION**

Test Mode : CH00, CH19 , CH39 - 1Mbps

CH00 (Lower) - 1Mbps

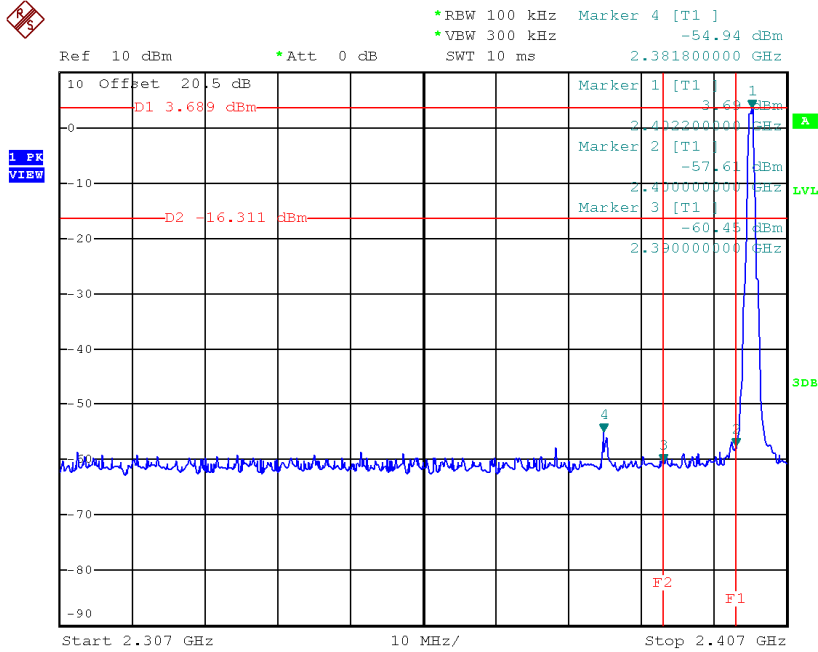

Date: 24.AUG.2015 15:04:12

CH39 (upper) - 1Mbps

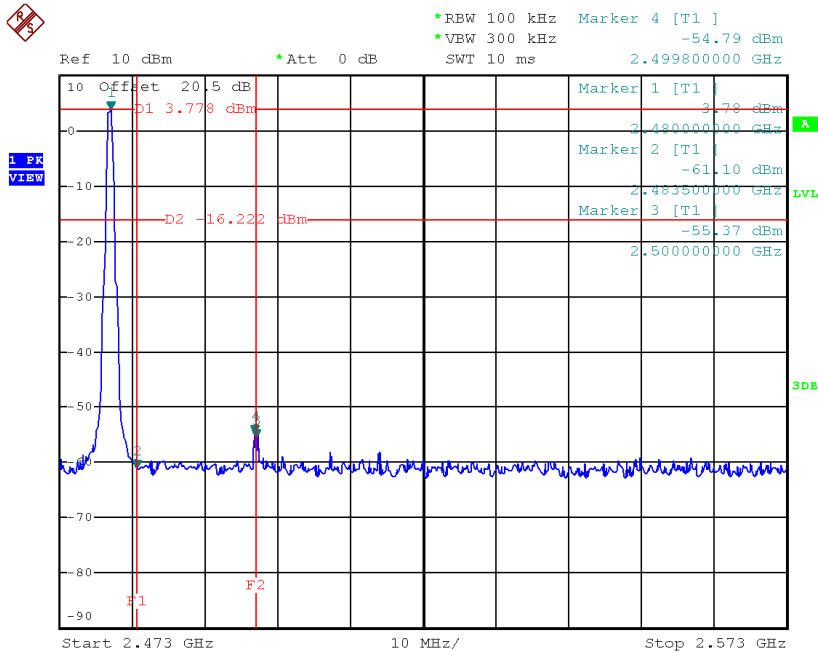

Date: 24.AUG.2015 15:11:35

CH00 (10 Harmonic of the frequency)

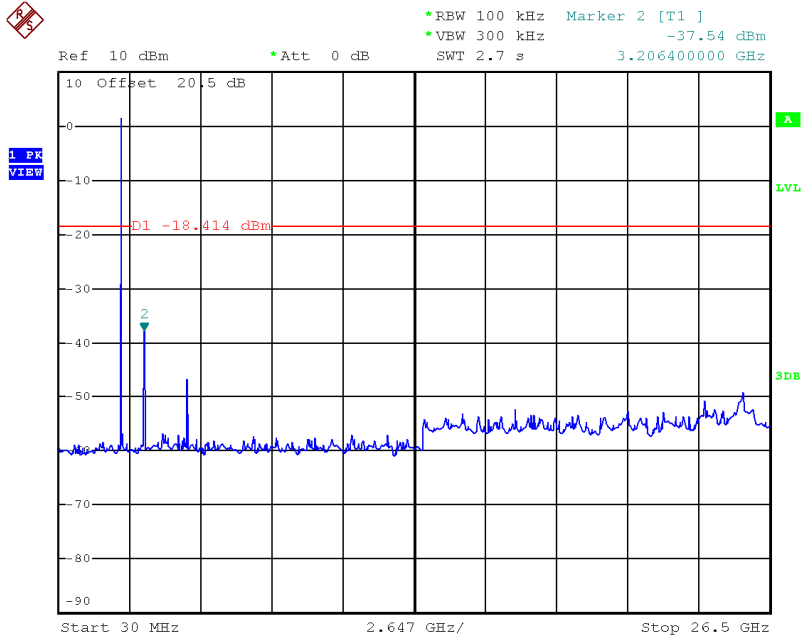

Date: 24.AUG.2015 15:04:24

CH19 (10 Harmonic of the frequency)

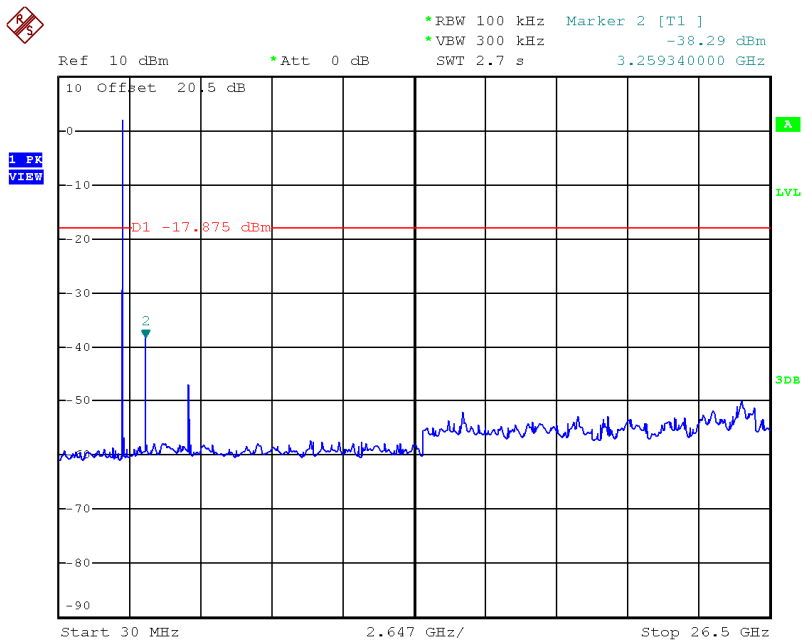

Date: 24.AUG.2015 15:05:48

CH39 (10 Harmonic of the frequency)

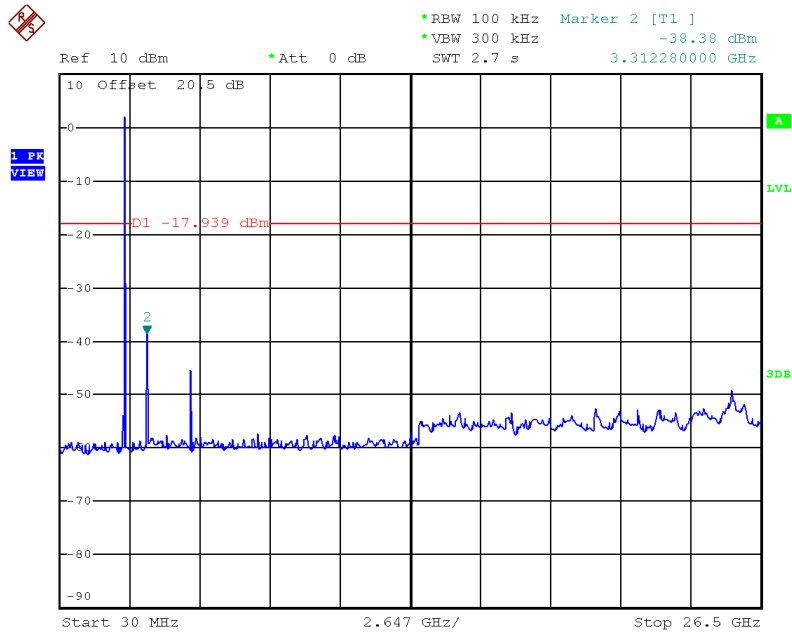

Date: 24.AUG.2015 15:11:48

ATTACHMENT H - POWER SPECTRAL DENSITY TEST

Frequency (MHz)	Power Density (dBm)	Max. Limit (dBm)	Result
2402	-10.60	8	Complies
2440	-10.30	8	Complies
2480	-10.37	8	Complies

TX CH00

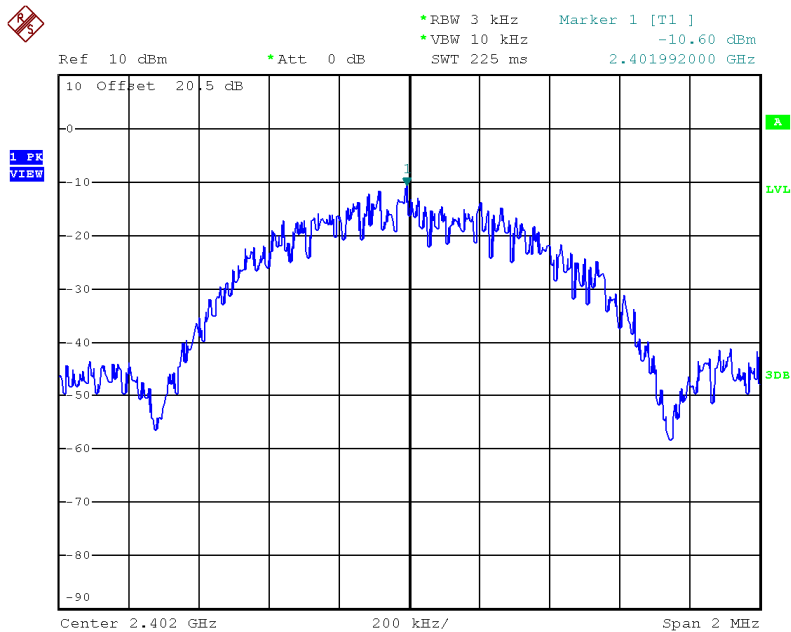

Date: 24.AUG.2015 15:04:30

TX CH19

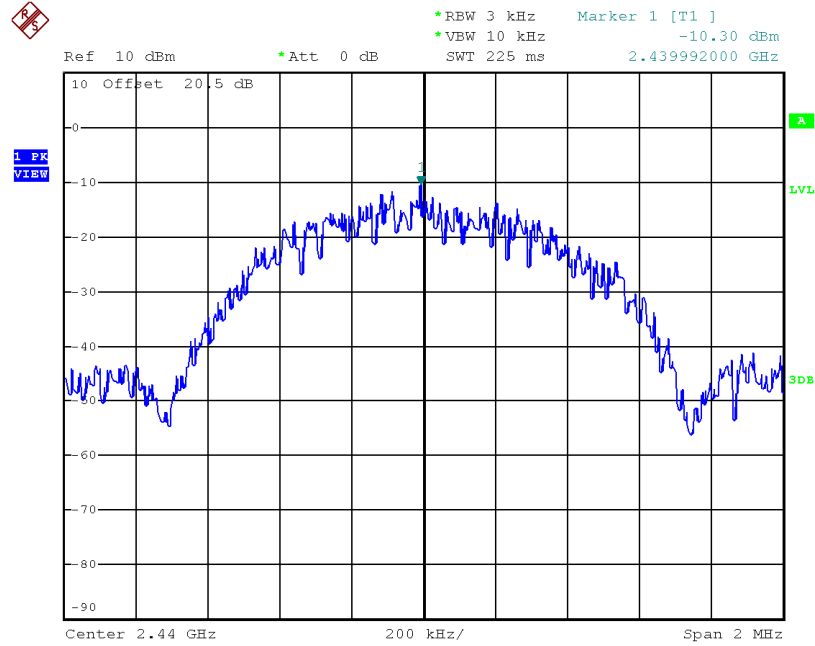

Date: 24.AUG.2015 15:05:53

TX CH39

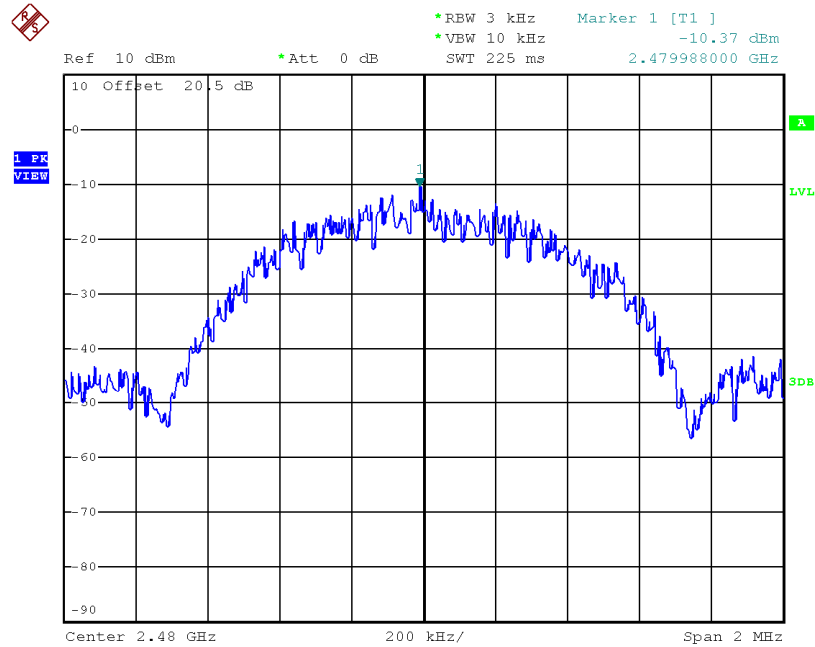

Date: 24.AUG.2015 15:11:53