



OET 65

TEST REPORT

Product Name	TETRA Digital Portable Terminal
Model	PT580H F5
FCC ID	YAMPT580HF5
Client	Hytera Communications Co.,Ltd.

TA Technology (Shanghai) Co., Ltd.

TA Technology (Shanghai) Co., Ltd.
Test Report

Report No. RZA1202-0269SAR01

Page 2 of 71

GENERAL SUMMARY

Product Name	TETRA Digital Portable Terminal	Model	PT580H F5
FCC ID	YAMPT580HF5	Report No.	RZA1202-0269SAR01
Client	Hytera Communications Co.,Ltd.		
Manufacturer	Hytera Communications Co.,Ltd.		
Reference Standard(s)	<p>IEEE Std C95.1, 1999: IEEE Standard for Safety Levels with Respect to Human Exposure to Radio Frequency Electromagnetic Fields, 3 KHz to 300 GHz.</p> <p>IEEE Std 1528™-2003: IEEE Recommended Practice for Determining the Peak Spatial-Average Specific Absorption Rate (SAR) in the Human Head from Wireless Communications Devices: Measurement Techniques.</p> <p>SUPPLEMENT C Edition 01-01 to OET BULLETIN 65 Edition 97-01 June 2001 including DA 02-1438 June 19, 2002: Evaluating Compliance with FCC Guidelines for Human Exposure to Radiofrequency Electromagnetic Fields Additional Information for Evaluation Compliance of Mobile and Portable Devices with FCC Limits for Human Exposure to Radiofrequency Emissions.</p> <p>KDB 643646 D01 SAR Test for PTT Radios v01: SAR Test Reduction Considerations for Occupational PTT Radios</p> <p>KDB 447498 D01 Mobile Portable RF Exposure v04: Mobile and Portable Device RF Exposure Procedures and Equipment Authorization Policies</p>		
Conclusion	<p>This portable wireless equipment has been measured in all cases requested by the relevant standards. Test results in Chapter 7 of this test report are below limits specified in the relevant standards.</p> <p>General Judgment: Pass</p> <div style="text-align: right;">  <p>(Stamp) Date of issue: April 19th, 2012</p> </div>		
Comment	The test result only responds to the measured sample.		

Approved by 初伟中
Director

Revised by 凌敏宝
SAR Manager

Performed by 秦明
SAR Engineer

TABLE OF CONTENT

1. General Information	5
1.1. Notes of the Test Report.....	5
1.2. Testing Laboratory	5
1.3. Applicant Information	6
1.4. Manufacturer Information.....	6
1.5. Information of EUT.....	7
1.6. The Maximum SAR _{1g} Values	8
1.7. Test Date	8
2. SAR Measurements System Configuration.....	9
2.1. SAR Measurement Set-up.....	9
2.2. DASY5 E-field Probe System	10
2.2.1. EX3DV4 Probe Specification	10
2.2.2. E-field Probe Calibration.....	11
2.3. Other Test Equipment	11
2.3.1. Device Holder for Transmitters	11
2.3.2. Phantom	12
2.4. Scanning Procedure	12
2.5. Data Storage and Evaluation	14
2.5.1. Data Storage.....	14
2.5.2. Data Evaluation by SEMCAD	14
3. Laboratory Environment.....	16
4. Tissue-equivalent Liquid	17
4.1. Tissue-equivalent Liquid Ingredients.....	17
4.2. Tissue-equivalent Liquid Properties	18
5. System Check.....	19
5.1. Description of System Check.....	19
5.2. System Check Results.....	20
6. Operational Conditions during Test.....	21
6.1. General Description of Test Procedures	21
6.2. Test Configuration	21
6.2.1. Face-Held Configuration.....	21
6.2.2. Body-Worn Configuration	21
7. Test Results	22
7.1. Conducted Power Results	22
7.2. SAR Test Results	23
8. Measurement Uncertainty.....	25
9. Main Test Instruments.....	27
ANNEX A: Test Layout	28
ANNEX B: System Check Results	29

TA Technology (Shanghai) Co., Ltd.
Test Report

Report No. RZA1202-0269SAR01

Page 4 of 71

ANNEX C: Graph Results	31
ANNEX D: Probe Calibration Certificate	41
ANNEX E: D835V2 Dipole Calibration Certificate	52
ANNEX F: DAE4 Calibration Certificate	60
ANNEX G: The EUT Appearances and Test Configuration	65

1. General Information

1.1. Notes of the Test Report

TA Technology (Shanghai) Co., Ltd. guarantees the reliability of the data presented in this test report, which is the results of measurements and tests performed for the items under test on the date and under the conditions stated in this test report and is based on the knowledge and technical facilities available at TA Technology (Shanghai) Co., Ltd. at the time of execution of the test.

TA Technology (Shanghai) Co., Ltd. is liable to the client for the maintenance by its personnel of the confidentiality of all information related to the items under test and the results of the test. This report only refers to the item that has undergone the test.

This report standalone dose not constitute or imply by its own an approval of the product by the certification Bodies or competent Authorities. This report cannot be used partially or in full for publicity and/or promotional purposes without previous written approval of **TA Technology (Shanghai) Co., Ltd.** and the Accreditation Bodies, if it applies.

If the electrical report is inconsistent with the printed one, it should be subject to the latter.

1.2. Testing Laboratory

Company: TA Technology (Shanghai) Co., Ltd.
Address: No.145, Jintang Rd, Tangzhen Industry Park, Pudong Shanghai, China
City: Shanghai
Post code: 201201
Country: P. R. China
Contact: Yang Weizhong
Telephone: +86-021-50791141/2/3
Fax: +86-021-50791141/2/3-8000
Website: <http://www.ta-shanghai.com>
E-mail: yangweizhong@ta-shanghai.com

TA Technology (Shanghai) Co., Ltd.

Test Report

Report No. RZA1202-0269SAR01

Page 6 of 71

1.3. Applicant Information

Company: Hytera Communications Co.,Ltd.
Address: HYT Tower, Hi-Tech Industrial Park North, Nanshan District, Shenzhen China
City: Shenzhen
Postal Code: 518057
Country: P. R. China
Telephone: +86-0755-26972999- 1210
Fax: 0755-86137130

1.4. Manufacturer Information

Company: Hytera Communications Co.,Ltd.
Address: HYT Tower, Hi-Tech Industrial Park North, Nanshan District, Shenzhen China
City: Shenzhen
Postal Code: 518057
Country: P. R. China
Telephone: +86-0755-26972999- 1210
Fax: 0755-86137130

TA Technology (Shanghai) Co., Ltd.
Test Report

Report No. RZA1202-0269SAR01

Page 7 of 71

1.5. Information of EUT

General Information

Device Type:	Portable Device
Exposure Category:	Controlled Environment /Occupational
State of Sample:	Prototype Unit
Product Name:	TETRA Digital Portable Terminal
S/N:	/
Hardware Version:	V3.0
Software Version:	V1.02.01.008
Antenna Type:	External Antenna
Device Operating Configurations:	
Test Modulation:	pi/4DQPSK (Digital)
Operating Frequency Range(s):	817MHz – 824MHz (UHF)
	862MHz – 869MHz (UHF)
Test Frequency:	817MHz – 824MHz – 862MHz – 869MHz
Note: 1. The test channels were selected in accordance with the procedures specified in FCC KDB 447498 D01 Mobile Portable RF Exposure v04 Section 6) c).	

TA Technology (Shanghai) Co., Ltd.

Test Report

Report No. RZA1202-0269SAR01

Page 8 of 71

Auxiliary Equipment Details

AE1:Battery

Model: BL1806
Manufacturer: Hytera Communications Co., Ltd.
S/N: /

AE2:Earphone

Model: EAN18
Manufacturer: Hytera Communications Co., Ltd.
S/N: /

Equipment Under Test (EUT) is a TETRA Digital Portable Terminal. SAR is tested for 817MHz – 824MHz and 862MHz – 869MHz. The EUT has one external antenna that is used for Tx/Rx.

The sample undergoing test was selected by the Client.

Components list please refer to documents of the manufacturer.

1.6. The Maximum SAR_{1g} Values

Mode	Frequency (MHz)	Position	SAR _{1g} (W/kg) 50% PTT duty cycle
UHF	862	Face-held	1.986
UHF	817	Body-Worn	1.965

1.7. Test Date

The test performed on April 8, 2012.

2. SAR Measurements System Configuration

2.1. SAR Measurement Set-up

The DASY5 system for performing compliance tests consists of the following items:

- A standard high precision 6-axis robot (Stäubli RX family) with controller and software. An arm extension for accommodating the data acquisition electronics (DAE).
- A dosimetric probe, i.e. an isotropic E-field probe optimized and calibrated for usage in tissue simulating liquid. The probe is equipped with an optical surface detector system.
- A data acquisition electronic (DAE) which performs the signal amplification, signal multiplexing, AD-conversion, offset measurements, mechanical surface detection, collision detection, etc. The unit is battery powered with standard or rechargeable batteries. The signal is optically transmitted to the EOC.
- A unit to operate the optical surface detector which is connected to the EOC.
- The Electro-Optical Coupler (EOC) performs the conversion from the optical into a digital electric signal of the DAE. The EOC is connected to the DASY5 measurement server.
- The DASY5 measurement server, which performs all real-time data evaluation for field measurements and surface detection, controls robot movements and handles safety operation. A computer operating Windows 2003
- DASY5 software and SEMCAD data evaluation software.
- Remote control with teach panel and additional circuitry for robot safety such as warning lamps, etc.
- The generic twin phantom enabling the testing of left-hand and right-hand usage.
- The device holder for handheld mobile phones.
- Tissue simulating liquid mixed according to the given recipes.
- System validation dipoles allowing to validate the proper functioning of the system.

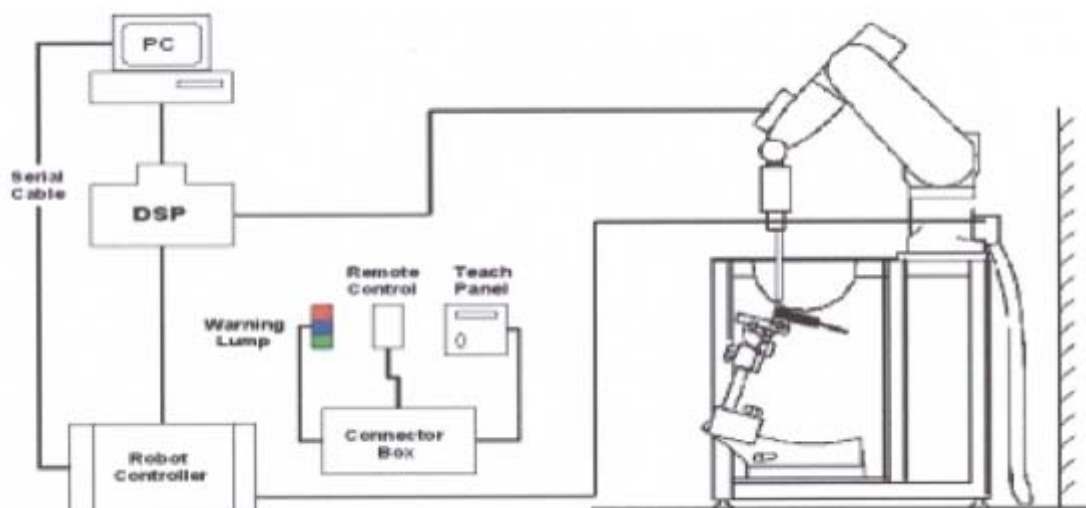

Figure 1. SAR Lab Test Measurement Set-up

2.2. DASY5 E-field Probe System

The SAR measurements were conducted with the dosimetric probe EX3DV4 (manufactured by SPEAG), designed in the classical triangular configuration and optimized for dosimetric evaluation.

2.2.1. EX3DV4 Probe Specification

Construction	Symmetrical design with triangular core Built-in shielding against static charges PEEK enclosure material (resistant to organic solvents, e.g., DGBE)
Calibration	ISO/IEC 17025 calibration service available
Frequency	10MHz to > 6 GHz Linearity: ± 0.2 dB (30MHz to 6 GHz)
Directivity	± 0.3 dB in HSL (rotation around probe axis) ± 0.5 dB in tissue material (rotation normal to probe axis)
Dynamic Range	10 μ W/g to > 100 mW/g Linearity: ± 0.2 dB (noise: typically < 1 μ W/g)
Dimensions	Overall length: 330 mm (Tip: 20 mm) Tip diameter: 2.5 mm (Body: 12 mm) Typical distance from probe tip to dipole centers: 1 mm
Application	High precision dosimetric measurements in any exposure scenario (e.g., very strong gradient fields). Only probe which enables compliance testing for frequencies up to 6 GHz with precision of better 30%.



Figure 2. EX3DV4 E-field Probe



Figure 3. EX3DV4 E-field probe

2.2.2. E-field Probe Calibration

Each probe is calibrated according to a dosimetric assessment procedure with accuracy better than $\pm 10\%$. The spherical isotropy was evaluated and found to be better than $\pm 0.25\text{dB}$. The sensitivity parameters (NormX, NormY, NormZ), the diode compression parameter (DCP) and the conversion factor (ConvF) of the probe are tested.

The free space E-field from amplified probe outputs is determined in a test chamber. This is performed in a TEM cell for frequencies below 1 GHz, and in a wave guide above 1 GHz for free space. For the free space calibration, the probe is placed in the volumetric center of the cavity and at the proper orientation with the field. The probe is then rotated 360 degrees.

E-field temperature correlation calibration is performed in a flat phantom filled with the appropriate simulated brain tissue. The measured free space E-field in the medium correlates to temperature rise in a dielectric medium. For temperature correlation calibration a RF transparent thermistor-based temperature probe is used in conjunction with the E-field probe.

$$\text{SAR} = C \frac{\Delta T}{\Delta t}$$

Where: Δt = Exposure time (30 seconds),
C = Heat capacity of tissue (brain or muscle),
 ΔT = Temperature increase due to RF exposure.
Or

$$\text{SAR} = \frac{|E|^2 \sigma}{\rho}$$

Where:
 σ = Simulated tissue conductivity,
 ρ = Tissue density (kg/m³).

2.3. Other Test Equipment

2.3.1. Device Holder for Transmitters

The DASY device holder is designed to cope with the different positions given in the standard.

It has two scales for device rotation (with respect to the body axis) and device inclination (with respect to the line between the ear reference points). The rotation centers for both scales is the ear reference point (ERP). Thus the device needs no repositioning when changing the angles.

The DASY device holder is constructed of low-loss POM material. The amount of dielectric material

has been reduced in the closest vicinity of the device, since measurements have suggested that the inference of the clamp on the test results could thus be lowered.



Figure 4. Device Holder

2.3.2. Phantom

The Generic Twin Phantom is constructed of a fiberglass shell integrated in a wooden Figure. The shape of the shell is based on data from an anatomical study designed to determine the maximum exposure in at least 90% of all users. It enables the dosimetric evaluation of left and right hand phone usage as well as body mounted usage at the flat phantom region. A cover prevents the evaporation of the liquid. Reference markings on the Phantom allow the complete setup of all predefined phantom positions and measurement grids by manually teaching three points in the robot.

Shell Thickness	2±0.1 mm
Filling Volume	Approx. 20 liters
Dimensions	810 x 1000 x 500 mm (H x L x W)
Available	Special



Figure 5. Generic Twin Phantom

2.4. Scanning Procedure

The DASY5 installation includes predefined files with recommended procedures for measurements and validation. They are read-only document files and destined as fully defined but unmeasured masks. All test positions (head or body-worn) are tested with the same configuration of test steps differing only in the grid definition for the different test positions.

- The “reference” and “drift” measurements are located at the beginning and end of the batch process. They measure the field drift at one single point in the liquid over the complete procedure. The indicated drift is mainly the variation of the EUT’s output power and should vary max. ± 5 %.
- The “surface check” measurement tests the optical surface detection system of the DASY5 system by repeatedly detecting the surface with the optical and mechanical surface detector and comparing the results. The output gives the detecting heights of both systems, the difference between the two systems and the standard deviation of the detection repeatability. Air bubbles or refraction in the liquid due to separation of the sugar-water mixture gives poor repeatability (above ± 0.1mm). To prevent wrong results tests are only executed when the liquid is free of air bubbles. The difference between the optical surface detection and the actual surface depends on the probe and is specified with each probe. (It does not depend on the surface reflectivity or the probe angle to the surface within ± 30°.)
- Area Scan
The Area Scan is used as a fast scan in two dimensions to find the area of high field values before running a detailed measurement around the hot spot. Before starting the area scan a grid

spacing of 15 mm x 15 mm is set. During the scan the distance of the probe to the phantom remains unchanged.

After finishing area scan, the field maxima within a range of 2 dB will be ascertained.

- Zoom Scan

Zoom Scans are used to estimate the peak spatial SAR values within a cubic averaging volume containing 1 g and 10 g of simulated tissue. The default Zoom Scan is done by 7x7x7 points within a cube whose base is centered around the maxima found in the preceding area scan.

- Spatial Peak Detection

The procedure for spatial peak SAR evaluation has been implemented and can determine values of masses of 1g and 10g, as well as for user-specific masses. The DASY5 system allows evaluations that combine measured data and robot positions, such as:

- maximum search
- extrapolation
- boundary correction
- peak search for averaged SAR

During a maximum search, global and local maxima searches are automatically performed in 2-D after each Area Scan measurement with at least 6 measurement points. It is based on the evaluation of the local SAR gradient calculated by the Quadratic Shepard's method. The algorithm will find the global maximum and all local maxima within -2 dB of the global maxima for all SAR distributions.

Extrapolation routines are used to obtain SAR values between the lowest measurement points and the inner phantom surface. The extrapolation distance is determined by the surface detection distance and the probe sensor offset. Several measurements at different distances are necessary for the extrapolation. Extrapolation routines require at least 10 measurement points in 3-D space. They are used in the Zoom Scan to obtain SAR values between the lowest measurement points and the inner phantom surface. The routine uses the modified Quadratic Shepard's method for extrapolation. For a grid using 7x7x7 measurement points with 5mm resolution amounting to 343 measurement points, the uncertainty of the extrapolation routines is less than 1% for 1g and 10g cubes.

- A Z-axis scan measures the total SAR value at the x-and y-position of the maximum SAR value found during the cube 7x7x7 scan. The probe is moved away in z-direction from the bottom of the SAM phantom in 5mm steps.

2.5. Data Storage and Evaluation

2.5.1. Data Storage

The DASY5 software stores the acquired data from the data acquisition electronics as raw data (in microvolt readings from the probe sensors), together with all necessary software parameters for the data evaluation (probe calibration data, liquid parameters and device frequency and modulation data) in measurement files with the extension “.DA4”. The software evaluates the desired unit and format for output each time the data is visualized or exported. This allows verification of the complete software setup even after the measurement and allows correction of incorrect parameter settings. For example, if a measurement has been performed with a wrong crest factor parameter in the device setup, the parameter can be corrected afterwards and the data can be re-evaluated.

The measured data can be visualized or exported in different units or formats, depending on the selected probe type ([V/m], [A/m], [°C], [mW/g], [mW/cm²], [dBrel], etc.). Some of these units are not available in certain situations or show meaningless results, e.g., a SAR output in a lossless media will always be zero. Raw data can also be exported to perform the evaluation with other software packages.

2.5.2. Data Evaluation by SEMCAD

The SEMCAD software automatically executes the following procedures to calculate the field units from the microvolt readings at the probe connector. The parameters used in the evaluation are stored in the configuration modules of the software:

Probe parameters:	- Sensitivity	Normi, a _{i0} , a _{i1} , a _{i2}
	- Conversion factor	ConvF _i
	- Diode compression point	Dcp _i
Device parameters:	- Frequency	f
	- Crest factor	cf
Media parameters:	- Conductivity	σ
	- Density	ρ

These parameters must be set correctly in the software. They can be found in the component documents or they can be imported into the software from the configuration files issued for the DASY5 components. In the direct measuring mode of the multimeter option, the parameters of the actual system setup are used. In the scan visualization and export modes, the parameters stored in the corresponding document files are used.

The first step of the evaluation is a linearization of the filtered input signal to account for the compression characteristics of the detector diode. The compensation depends on the input signal, the diode type and the DC-transmission factor from the diode to the evaluation electronics.

TA Technology (Shanghai) Co., Ltd.
Test Report

Report No. RZA1202-0269SAR01

Page 15 of 71

If the exciting field is pulsed, the crest factor of the signal must be known to correctly compensate for peak power. The formula for each channel can be given as:

$$V_i = U_i + U_i^2 \cdot c f / d c p_i$$

With V_i = compensated signal of channel i (i = x, y, z)

U_i = input signal of channel i (i = x, y, z)

cf = crest factor of exciting field (DASY parameter)

dcp_i = diode compression point (DASY parameter)

From the compensated input signals the primary field data for each channel can be evaluated:

E-field probes: $E_i = (V_i / Norm_i \cdot ConvF)^{1/2}$

H-field probes: $H_i = (V_i)^{1/2} \cdot (a_{i0} + a_{i1} f + a_{i2} f^2) / f$

With V_i = compensated signal of channel i (i = x, y, z)

$Norm_i$ = sensor sensitivity of channel i (i = x, y, z)
[mV/(V/m)²] for E-field Probes

$ConvF$ = sensitivity enhancement in solution

a_{ij} = sensor sensitivity factors for H-field probes

f = carrier frequency [GHz]

E_i = electric field strength of channel i in V/m

H_i = magnetic field strength of channel i in A/m

The RSS value of the field components gives the total field strength (Hermitian magnitude):

$$E_{tot} = (E_x^2 + E_y^2 + E_z^2)^{1/2}$$

The primary field data are used to calculate the derived field units.

$$SAR = (E_{tot}^2 \cdot \sigma) / (\rho \cdot 1000)$$

with **SAR** = local specific absorption rate in mW/g

E_{tot} = total field strength in V/m

σ = conductivity in [mho/m] or [Siemens/m]

ρ = equivalent tissue density in g/cm³

Note that the density is normally set to 1 (or 1.06), to account for actual brain density rather than the density of the simulation liquid. The power flow density is calculated assuming the excitation field to be a free space field.

$$P_{pwe} = E_{tot}^2 / 3770 \quad \text{or} \quad P_{pwe} = H_{tot}^2 \cdot 37.7$$

with **P_{pwe}** = equivalent power density of a plane wave in mW/cm²

E_{tot} = total electric field strength in V/m

H_{tot} = total magnetic field strength in A/m

3. Laboratory Environment

Table 1: The Requirements of the Ambient Conditions

Temperature	Min. = 18°C, Max. = 25 °C
Relative humidity	Min. = 30%, Max. = 70%
Ground system resistance	< 0.5 Ω
Ambient noise is checked and found very low and in compliance with requirement of standards.	
Reflection of surrounding objects is minimized and in compliance with requirement of standards.	

4. Tissue-equivalent Liquid

4.1. Tissue-equivalent Liquid Ingredients

The liquid is consisted of water, sugar, salt, Preventol and Cellulose. The liquid has previously been proven to be suited for worst-case. The Table 2 and Table 3 show the detail solution. It's satisfying the latest tissue dielectric parameters requirements proposed by the OET 65.

Table 2: Composition of the Head Tissue Equivalent Matter

MIXTURE%	FREQUENCY(Brain) 835MHz
Water	41.45
Sugar	56
Salt	1.45
Preventol	0.1
Cellulose	1.0
Dielectric Parameters Target Value	f=835MHz $\epsilon=41.5$ $\sigma=0.9$

Table 3: Composition of the Body Tissue Equivalent Matter

MIXTURE%	FREQUENCY(Body) 835MHz
Water	52.5
Sugar	45
Salt	1.4
Preventol	0.1
Cellulose	1.0
Dielectric Parameters Target Value	f=835MHz $\epsilon=55.2$ $\sigma=0.97$

TA Technology (Shanghai) Co., Ltd.
Test Report

Report No. RZA1202-0269SAR01

Page 18 of 71

4.2. Tissue-equivalent Liquid Properties

Table 4: Dielectric Performance of Head Tissue Simulating Liquid

Frequency	Description	Dielectric Parameters		Temp ℃
		ϵ_r	$\sigma(\text{s/m})$	
835MHz (head)	Target value ±5% window	41.50 39.43 — 43.58	0.90 0.86 — 0.95	22.0
	Measurement value 2012-4-8	42.10	0.90	21.7

Table 5: Dielectric Performance of Body Tissue Simulating Liquid

Frequency	Description	Dielectric Parameters		Temp ℃
		ϵ_r	$\sigma(\text{s/m})$	
835MHz (body)	Target value ±5% window	55.20 52.44 — 57.96	0.97 0.92 — 1.02	22.0
	Measurement value 2012-4-8	54.26	0.99	21.7

5. System Check

5.1. Description of System Check

The manufacturer calibrates the probes annually. Dielectric parameters of the tissue simulants were measured every day using the dielectric probe kit and the network analyser. A system check measurement was made following the determination of the dielectric parameters of the simulant, using the dipole validation kit. A power level of 250 mW was supplied to the dipole antenna, which was placed under the flat section of the twin SAM phantom. The system check results (dielectric parameters and SAR values) are given in the table 6 and table 7.

System check results have to be equal or near the values determined during dipole calibration with the relevant liquids and test system ($\pm 10\%$).

System check is performed regularly on all frequency bands where tests are performed with the DASY5 system.

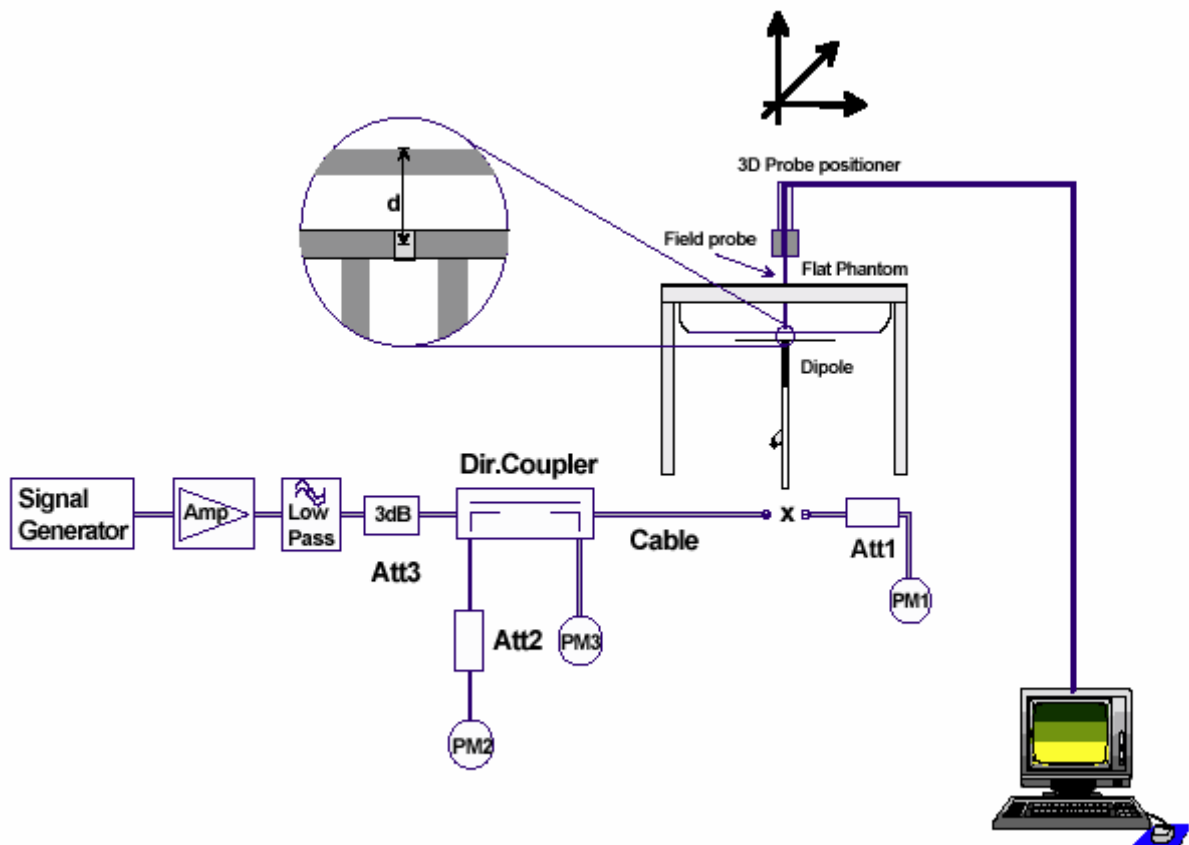

Figure 6. System Check Set-up

TA Technology (Shanghai) Co., Ltd.
Test Report

5.2. System Check Results

Table 6: System Check for Head Tissue Simulating Liquid

Frequency	Test Date	Dielectric Parameters		Temp	250mW Measured SAR _{1g}	1W Normalized SAR _{1g}	1W Target SAR _{1g} (±10% Deviation)
		ϵ_r	σ (s/m)	(°C)	(W/kg)		
835MHz	2012-4-8	42.10	0.90	21.7	2.40	9.60	9.34 (8.41~10.27)

Note: 1. The graph results see ANNEX B.
2. Target Value derive from the calibration certificate

Table 7: System Check for Body Tissue Simulating Liquid

Frequency	Test Date	Dielectric Parameters		Temp	250mW Measured SAR _{1g}	1W Normalized SAR _{1g}	1W Target SAR _{1g} (±10% Deviation)
		ϵ_r	σ (s/m)	(°C)	(W/kg)		
835MHz	2012-4-8	54.26	0.99	21.7	2.54	10.16	9.46 (8.51~10.41)

Note: 1. The graph results see ANNEX B.
2. Target Value derive from the calibration certificate

6. Operational Conditions during Test

6.1. General Description of Test Procedures

The spatial peak SAR values were assessed for UHF (817MHz, 824MHz, 862MHz, 869MHz) systems. Batterys and accessories shall be specified by the manufacturer. The EUT batterys must be fully charged and checked periodically during the test to ascertain uniform power output.

6.2. Test Configuration

6.2.1. Face-Held Configuration

The front of the EUT is towards the phantom.

The front surface of the EUT is positioned at 25mm parallel to the flat phantom.

The surface of the EUT antenna is positioned at 44mm to the flat phantom.

6.2.2. Body-Worn Configuration

The back of the EUT is towards the phantom.

The EUT is wearing the earphone during the test.

The belt clip of the EUT directed tightly to touch the bottom of the flat phantom.

The surface of the EUT antenna is positioned at 23mm to the flat phantom.

7. Test Results

7.1. Conducted Power Results

Table 8: Conducted Power Measurement Results

Digital UHF (25KHz)	Conducted Power			
	817MHz	824MHz	862MHz	869MHz
Test Result (dBm)	33.14	32.86	32.24	32.87

TA Technology (Shanghai) Co., Ltd.
Test Report

7.2. SAR Test Results

7.2.1. UHF

Table 9: SAR Values (UHF)

Limits	1 g Average (W/kg)		Power Drift (dB)	Graph Results
	8.0		± 0.21	
Frequency	Duty Cycle		Power Drift (dB)	
	100%	50%		
The EUT display towards phantom for 25 KHz(Digital, Face Held)				
817MHz	3.640	1.820	0.156	Figure 9
824MHz	3.810	1.905	0.175	Figure 10
862MHz	3.820	1.910	0.169	Figure 11
869MHz	2.640	1.320	-0.106	Figure 12
The EUT display towards ground for 25 KHz (Digital, Body-Worn)				
817MHz	3.820(max.cube)	1.910	0.123	Figure 13
824MHz	3.840(max.cube)	1.920	0.098	Figure 14
862MHz	2.480(max.cube)	1.240	-0.051	Figure 15
869MHz	2.310	1.155	-0.005	Figure 16
<p>Note: 1. The (max.cube) labeling indicates that during the grid scanning an additional peak was found which was within 2.0dB of the highest peak. The value of the highest cube is given in the table above; the value from the second assessed cube is given in the SAR distribution plots (See ANNEX C).</p>				

TA Technology (Shanghai) Co., Ltd.
Test Report

Table 10: SAR Values are scaled for the power drift

Limits	1 g Average (W/kg)		Power Drift (dB)	+ Power Drift 10^(dB/10)	SAR 1g (W/kg) (include + power drift)	
	8.0		± 0.21		Duty Cycle	
Frequency	Duty Cycle		Power Drift(dB)		Duty Cycle	
	100%	50%			100%	50%
The EUT display towards phantom for 25 KHz(Digital, Face Held)						
817MHz	3.640	1.820	0.156	1.037	3.773	1.887
824MHz	3.810	1.905	0.175	1.041	3.967	1.983
862MHz	3.820	1.910	0.169	1.040	3.972	1.986
869MHz	2.640	1.320	0.106	1.025	2.705	1.353
The EUT display towards ground for 25 KHz (Digital, Body-Worn)						
817MHz	3.820	1.910	0.123	1.029	3.930	1.965
824MHz	3.840	1.920	0.098	1.023	3.928	1.964
862MHz	2.480	1.240	0.051	1.012	2.509	1.255
869MHz	2.310	1.155	0.005	1.001	2.313	1.156
<p>Note: 1. The value with blue color is the maximum SAR Value of each test band. 2. The SAR levels reported are based on 50% PTT duty factor including SAR droop. 3. The Exposure category about EUT: controlled environment/Occupational, so the SAR limit is 8.0 W/kg averaged over any 1 gram of tissue.</p>						

TA Technology (Shanghai) Co., Ltd.
Test Report

Report No. RZA1202-0269SAR01

Page 25 of 71

8. Measurement Uncertainty

No.	source	Type	Uncertainty Value (%)	Probability Distribution	k	c _i	Standard uncertainty u _i (%)	Degree of freedom V _{eff} or V _i
1	System repetivity	A	0.5	N	1	1	0.5	9
Measurement system								
2	-probe calibration	B	6.0	N	1	1	6.0	∞
3	-axial isotropy of the probe	B	4.7	R	$\sqrt{3}$	$\sqrt{0.5}$	1.9	∞
4	- Hemispherical isotropy of the probe	B	9.4	R	$\sqrt{3}$	$\sqrt{0.5}$	3.9	∞
6	-boundary effect	B	1.9	R	$\sqrt{3}$	1	1.1	∞
7	-probe linearity	B	4.7	R	$\sqrt{3}$	1	2.7	∞
8	- System detection limits	B	1.0	R	$\sqrt{3}$	1	0.6	∞
9	-readout Electronics	B	1.0	N	1	1	1.0	∞
10	-response time	B	0	R	$\sqrt{3}$	1	0	∞
11	-integration time	B	4.32	R	$\sqrt{3}$	1	2.5	∞
12	-noise	B	0	R	$\sqrt{3}$	1	0	∞
13	-RF Ambient Conditions	B	3	R	$\sqrt{3}$	1	1.73	∞
14	-Probe Positioner Mechanical Tolerance	B	0.4	R	$\sqrt{3}$	1	0.2	∞
15	-Probe Positioning with respect to Phantom Shell	B	2.9	R	$\sqrt{3}$	1	1.7	∞
16	-Extrapolation, interpolation and Integration Algorithms for Max. SAR Evaluation	B	3.9	R	$\sqrt{3}$	1	2.3	∞
Test sample Related								
17	-Test Sample Positioning	A	2.9	N	1	1	2.9	71
18	-Device Holder Uncertainty	A	4.1	N	1	1	4.1	5
19	-Output Power Variation - SAR drift measurement	B	5.0	R	$\sqrt{3}$	1	2.9	∞
Physical parameter								
20	-phantom	B	4.0	R	$\sqrt{3}$	1	2.3	∞

TA Technology (Shanghai) Co., Ltd.
Test Report

Report No. RZA1202-0269SAR01

Page 26 of 71

21	-liquid conductivity (deviation from target)	B	5.0	R	$\sqrt{3}$	0.64	1.8	∞
22	-liquid conductivity (measurement uncertainty)	B	2.5	N	1	0.64	1.6	9
23	-liquid permittivity (deviation from target)	B	5.0	R	$\sqrt{3}$	0.6	1.7	∞
24	-liquid permittivity (measurement uncertainty)	B	2.5	N	1	0.6	1.5	9
Combined standard uncertainty		$u_c = \sqrt{\sum_{i=1}^{21} c_i^2 u_i^2}$					12.16	
Expanded uncertainty (confidence interval of 95 %)		$u_e = 2u_c$		N	k=2	23.00		

TA Technology (Shanghai) Co., Ltd.
Test Report

Report No. RZA1202-0269SAR01

Page 27 of 71

9. Main Test Instruments

Table 11: List of Main Instruments

No.	Name	Type	Serial Number	Calibration Date	Valid Period
01	Network analyzer	Agilent 8753E	US37390326	September 12, 2011	One year
02	Dielectric Probe Kit	Agilent 85070E	US44020115	No Calibration Requested	
03	Power meter	Agilent E4417A	GB41291714	March 11, 2012	One year
04	Power sensor	Agilent N8481H	MY50350004	September 25, 2011	One year
05	Power sensor	E9327A	US40441622	September 24, 2011	One year
06	Signal Generator	HP 8341B	2730A00804	September 12, 2011	One year
07	Amplifier	IXA-020	0401	No Calibration Requested	
08	E-field Probe	EX3DV4	3816	October 3, 2011	One year
09	DAE	DAE4	871	November 22, 2011	One year
10	Validation Kit 835MHz	D835V2	4d020	August 26, 2011	One year
11	Dual directional coupler	778D-012	5051P	August 21, 2011	One year
12	Temperature Probe	JM222	AA1009129	March 15, 2012	One year
13	Hygrothermograph	WS-1	64591	September 28, 2011	One year

*****END OF REPORT *****

ANNEX A: Test Layout



Picture 1: Specific Absorption Rate Test Layout



Picture 2: Liquid depth in the Flat Phantom (835MHz, 15.4cm depth)

ANNEX B: System Check Results

System Performance Check at 835 MHz Head TSL

DUT: Dipole 835 MHz; Type: D835V2; Serial: D835V2 - SN: 4d020

Date/Time: 4/8/2012 8:20:21 AM

Communication System: CW; Frequency: 835 MHz; Duty Cycle: 1:1

Medium parameters used: $f = 835$ MHz; $\sigma = 0.90$ mho/m; $\epsilon_r = 42.10$; $\rho = 1000$ kg/m³

Ambient Temperature: 22.3 °C Liquid Temperature: 21.7 °C

Phantom section: Flat Section

DASY5 Configuration:

Probe: EX3DV4 - SN3816; ConvF(9.22, 9.22, 9.22) Calibrated: 10/3/2011;

Electronics: DAE4 Sn871; Calibrated: 11/22/2011

Phantom: SAM1; Type: SAM; Serial: TP-1534

Measurement SW: DASY5, V5.2 Build 162; SEMCAD X Version 14.0 Build 59

d=15mm, Pin=250mW/Area Scan (101x121x1): Measurement grid: dx=15mm, dy=15mm
Maximum value of SAR (interpolated) = 2.56 mW/g

d=15mm, Pin=250mW/Zoom Scan (7x7x7)/Cube 0: Measurement grid: dx=5mm, dy=5mm, dz=5mm

Reference Value = 51.1 V/m; Power Drift = -0.037 dB

Peak SAR (extrapolated) = 3.54 W/kg

SAR(1 g) = 2.40 mW/g; SAR(10 g) = 1.58 mW/g

Maximum value of SAR (measured) = 2.63 mW/g

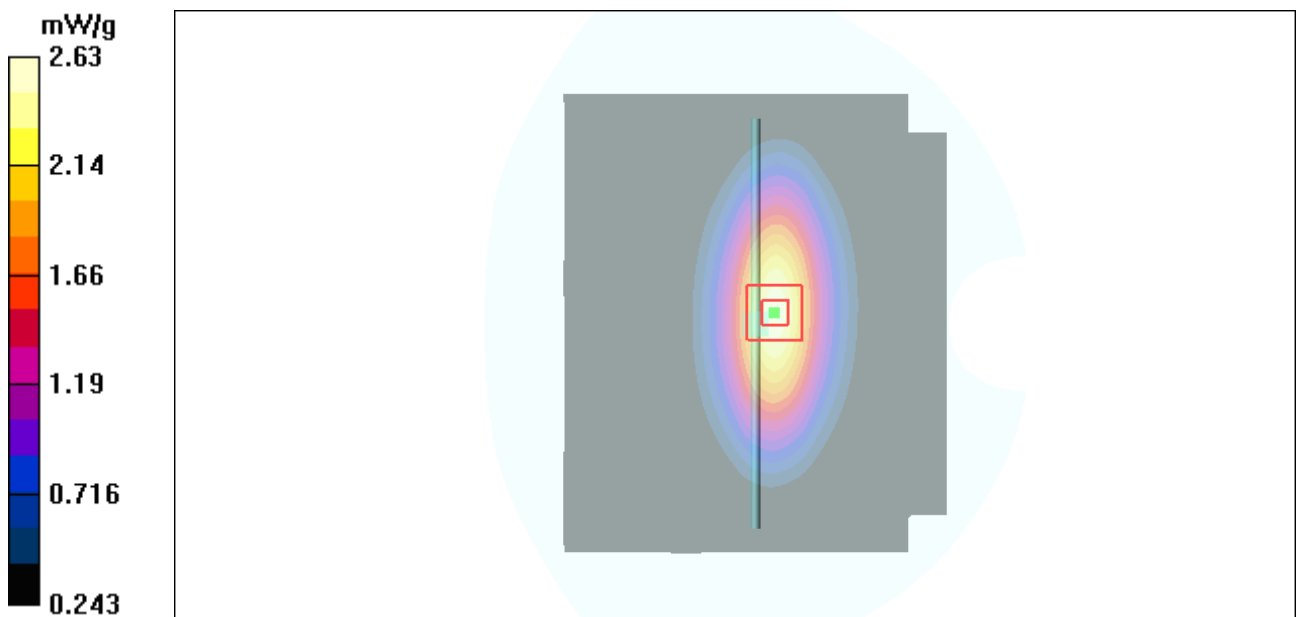

Figure 7 System Performance Check 835MHz 250mW

System Performance Check at 835 MHz Body TSL

DUT: Dipole 835 MHz; Type: D835V2; Serial: D835V2 - SN: 4d020

Date/Time: 4/8/2012 6:51:21 AM

Communication System: CW; Frequency: 835 MHz; Duty Cycle: 1:1

Medium parameters used: $f = 835 \text{ MHz}$; $\sigma = 0.99 \text{ mho/m}$; $\epsilon_r = 54.26$; $\rho = 1000 \text{ kg/m}^3$

Ambient Temperature: 22.3 °C Liquid Temperature: 21.7 °C

DASY5 Configuration:

Probe: EX3DV4 - SN3816; ConvF(9.38, 9.38, 9.38) Calibrated: 10/3/2011;

Electronics: DAE4 Sn871; Calibrated: 11/22/2011

Phantom: SAM1; Type: SAM; Serial: TP-1534

Measurement SW: DASY5, V5.2 Build 162; SEMCAD X Version 14.0 Build 59

d=15mm, Pin=250mW/Area Scan (61x121x1): Measurement grid: dx=15mm, dy=15mm
Maximum value of SAR (interpolated) = 2.72 mW/g

d=15mm, Pin=250mW/Zoom Scan (7x7x7)/Cube 0: Measurement grid: dx=5mm, dy=5mm, dz=5mm

Reference Value = 50.9 V/m; Power Drift = 0.023 dB

Peak SAR (extrapolated) = 3.63 W/kg

SAR(1 g) = 2.54 mW/g; SAR(10 g) = 1.64 mW/g

Maximum value of SAR (measured) = 2.72 mW/g

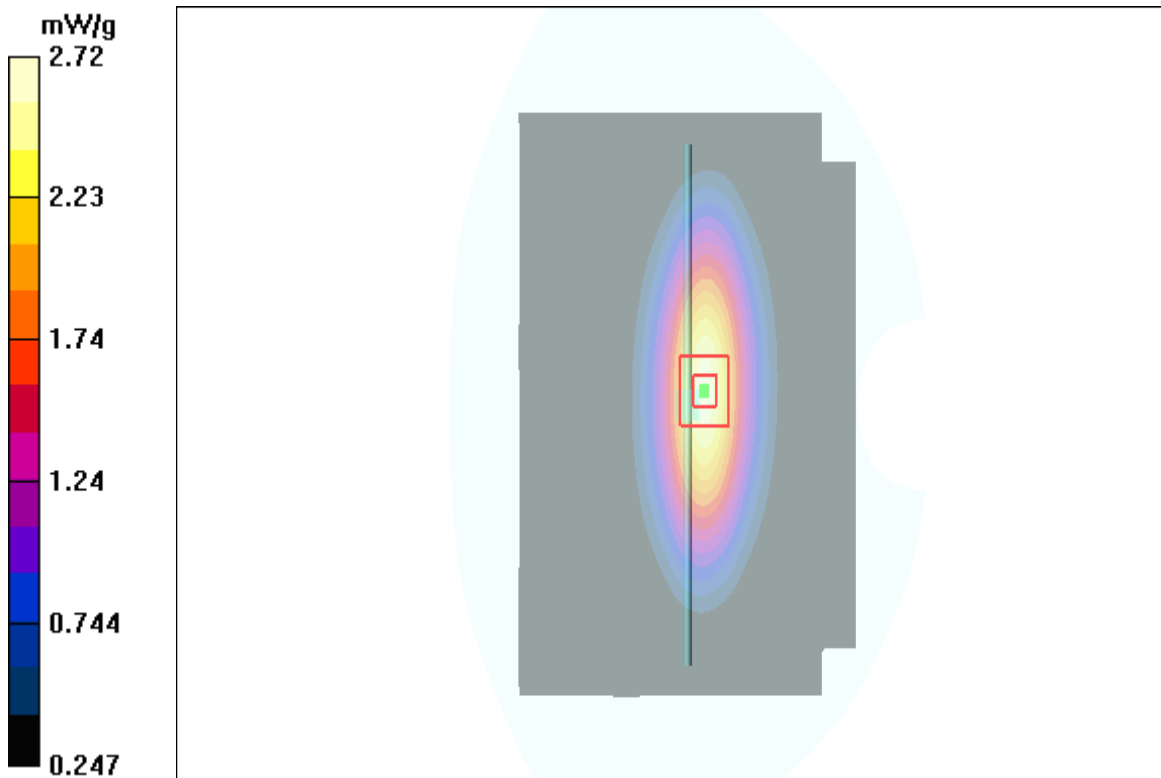

Figure 8 System Performance Check 835MHz 250mW

ANNEX C: Graph Results

Face Held, Front towards Phantom 817MHz (25 KHz Channel Spacing)

Date/Time: 4/8/2012 9:40:29 AM

Communication System: PTT 800; Frequency: 817 MHz; Duty Cycle: 1:1

Medium parameters used: $f = 817$ MHz; $\sigma = 0.884$ mho/m; $\epsilon_r = 42.46$; $\rho = 1000$ kg/m³

Ambient Temperature: 22.3 °C Liquid Temperature: 21.5°C

Phantom section: Flat Section

DASY5 Configuration:

Probe: EX3DV4 - SN3816; ConvF(9.22, 9.22, 9.22) Calibrated: 10/3/2011;

Electronics: DAE4 Sn871; Calibrated: 11/22/2011

Phantom: SAM1; Type: SAM; Serial: TP-1534

Measurement SW: DASY5, V5.2 Build 162; SEMCAD X Version 14.0 Build 59

Towards Phantom 817MHz/Area Scan (51x121x1): Measurement grid: dx=15mm, dy=15mm

Maximum value of SAR (interpolated) = 3.77 mW/g

Towards Phantom 817MHz/Zoom Scan (7x7x7)/Cube 0: Measurement grid: dx=5mm, dy=5mm, dz=5mm

Reference Value = 51.3 V/m; Power Drift = 0.156 dB

Peak SAR (extrapolated) = 4.55 W/kg

SAR(1 g) = 3.64 mW/g; SAR(10 g) = 2.75 mW/g

Maximum value of SAR (measured) = 3.82 mW/g

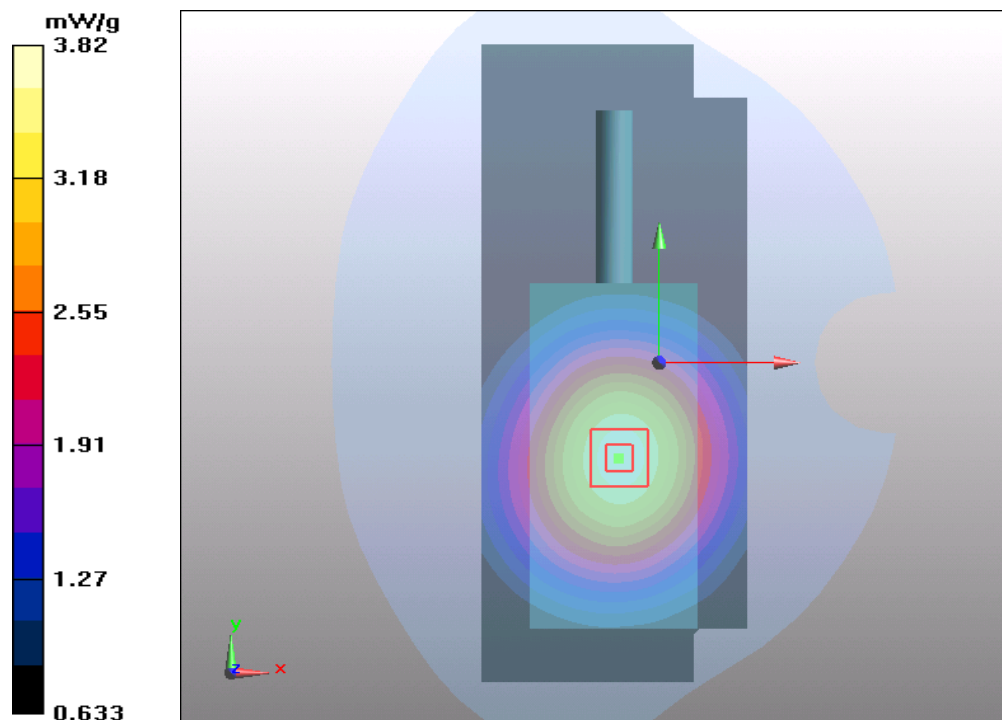

Figure 9 Face Held, Front towards Phantom 817MHz (25 KHz Channel Spacing)

Face Held, Front towards Phantom 824MHz (25 KHz Channel Spacing)

Date/Time: 4/8/2012 11:12:23 AM

Communication System: PTT 800; Frequency: 824 MHz; Duty Cycle: 1:1

Medium parameters used: $f = 824 \text{ MHz}$; $\sigma = 0.89 \text{ mho/m}$; $\epsilon_r = 42.4$; $\rho = 1000 \text{ kg/m}^3$

Ambient Temperature: $22.3 \text{ }^\circ\text{C}$ Liquid Temperature: 21.5°C

Phantom section: Flat Section

DASY5 Configuration:

Probe: EX3DV4 - SN3816; ConvF(9.22, 9.22, 9.22) Calibrated: 10/3/2011;

Electronics: DAE4 Sn871; Calibrated: 11/22/2011

Phantom: SAM1; Type: SAM; Serial: TP-1534

Measurement SW: DASY5, V5.2 Build 162; SEMCAD X Version 14.0 Build 59

Towards Phantom 824MHz/Area Scan (51x121x1): Measurement grid: $dx=15\text{mm}$, $dy=15\text{mm}$

Maximum value of SAR (interpolated) = 3.92 mW/g

Towards Phantom 824MHz/Zoom Scan (7x7x7)/Cube 0: Measurement grid: $dx=5\text{mm}$, $dy=5\text{mm}$, $dz=5\text{mm}$

Reference Value = 52.3 V/m ; Power Drift = 0.175 dB

Peak SAR (extrapolated) = 4.74 W/kg

SAR(1 g) = 3.81 mW/g ; SAR(10 g) = 2.87 mW/g

Maximum value of SAR (measured) = 4 mW/g

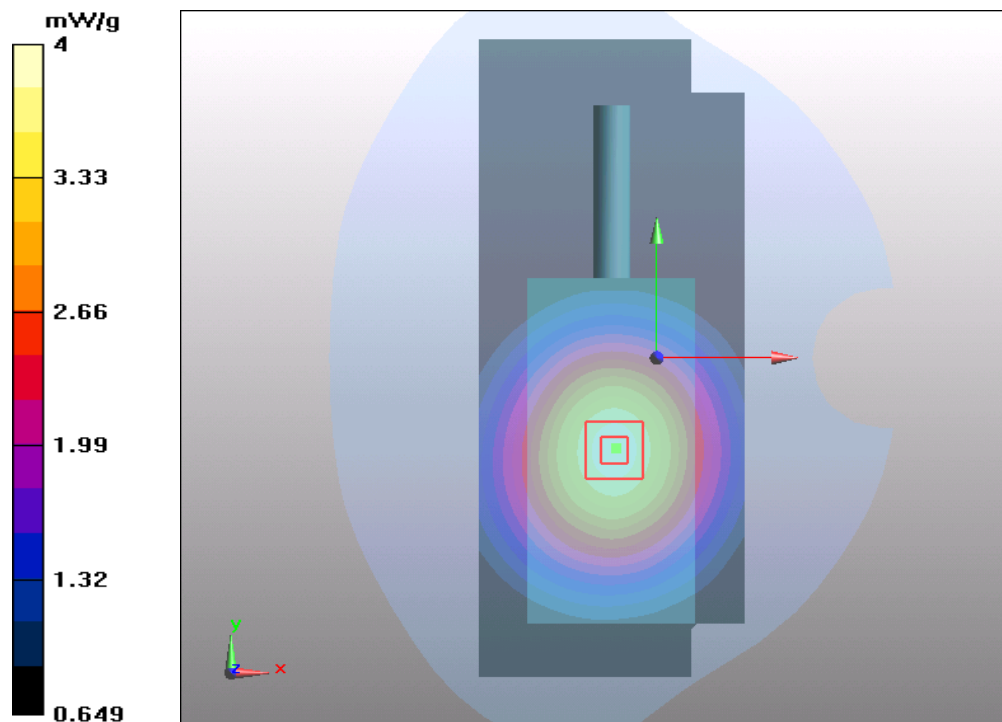

Figure 10 Face Held, Front towards Phantom 824MHz (25 KHz Channel Spacing)

Face Held, Front towards Phantom 862MHz (25 KHz Channel Spacing)

Date/Time: 4/8/2012 12:16:07 PM

Communication System: PTT 800; Frequency: 862 MHz; Duty Cycle: 1:1

Medium parameters used: $f = 862 \text{ MHz}$; $\sigma = 0.93 \text{ mho/m}$; $\epsilon_r = 41.9$; $\rho = 1000 \text{ kg/m}^3$

Ambient Temperature: $22.3 \text{ }^\circ\text{C}$ Liquid Temperature: 21.5°C

Phantom section: Flat Section

DASY5 Configuration:

Probe: EX3DV4 - SN3816; ConvF(9.22, 9.22, 9.22) Calibrated: 10/3/2011;

Electronics: DAE4 Sn871; Calibrated: 11/22/2011

Phantom: SAM1; Type: SAM; Serial: TP-1534

Measurement SW: DASY5, V5.2 Build 162; SEMCAD X Version 14.0 Build 59

Towards Phantom 862MHz/Area Scan (51x121x1): Measurement grid: $dx=15\text{mm}$, $dy=15\text{mm}$

Maximum value of SAR (interpolated) = 3.91 mW/g

Towards Phantom 862MHz/Zoom Scan (7x7x7)/Cube 0: Measurement grid: $dx=5\text{mm}$, $dy=5\text{mm}$, $dz=5\text{mm}$

Reference Value = 47.8 V/m ; Power Drift = 0.169 dB

Peak SAR (extrapolated) = 4.74 W/kg

SAR(1 g) = 3.82 mW/g ; SAR(10 g) = 2.89 mW/g

Maximum value of SAR (measured) = 4.02 mW/g

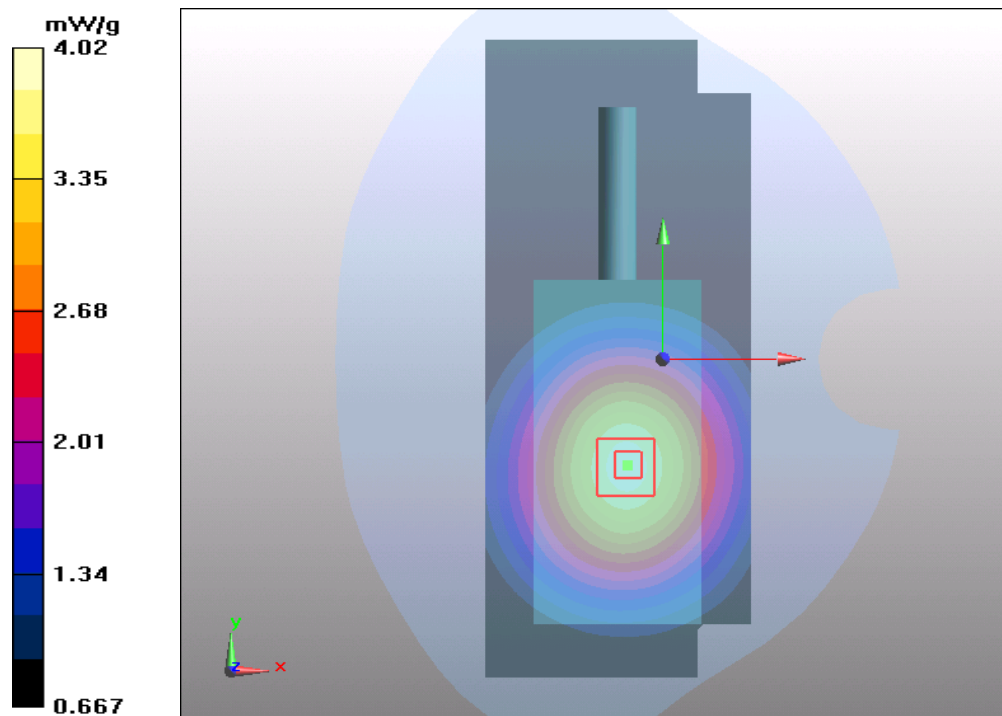

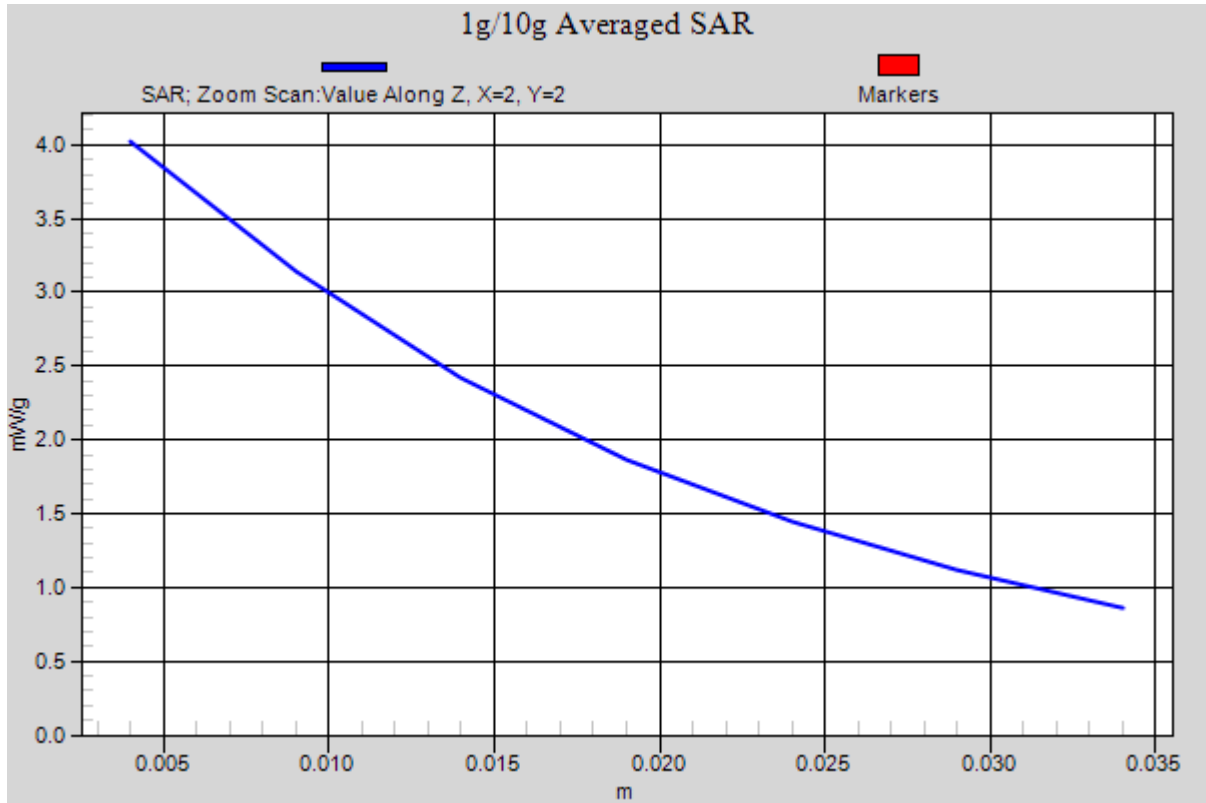

Figure 11 Face Held, Front towards Phantom 862MHz (25 KHz Channel Spacing)

Face Held, Front towards Phantom 869MHz (25 KHz Channel Spacing)

Date/Time: 4/8/2012 12:51:09 PM

Communication System: PTT 800; Frequency: 869 MHz; Duty Cycle: 1:1

Medium parameters used: $f = 869 \text{ MHz}$; $\sigma = 0.936 \text{ mho/m}$; $\epsilon_r = 41.83$; $\rho = 1000 \text{ kg/m}^3$

Ambient Temperature: $22.3 \text{ }^\circ\text{C}$ Liquid Temperature: 21.5°C

Phantom section: Flat Section

DASY5 Configuration:

Probe: EX3DV4 - SN3816; ConvF(9.22, 9.22, 9.22) Calibrated: 10/3/2011;

Electronics: DAE4 Sn871; Calibrated: 11/22/2011

Phantom: SAM1; Type: SAM; Serial: TP-1534

Measurement SW: DASY5, V5.2 Build 162; SEMCAD X Version 14.0 Build 59

Towards Phantom 869MHz/Area Scan (51x121x1): Measurement grid: $dx=15\text{mm}$, $dy=15\text{mm}$

Maximum value of SAR (interpolated) = 2.82 mW/g

Towards Phantom 869MHz/Zoom Scan (7x7x7)/Cube 0: Measurement grid: $dx=5\text{mm}$, $dy=5\text{mm}$, $dz=5\text{mm}$

Reference Value = 34.7 V/m ; Power Drift = -0.106 dB

Peak SAR (extrapolated) = 3.31 W/kg

SAR(1 g) = 2.64 mW/g ; SAR(10 g) = 1.97 mW/g

Maximum value of SAR (measured) = 2.78 mW/g

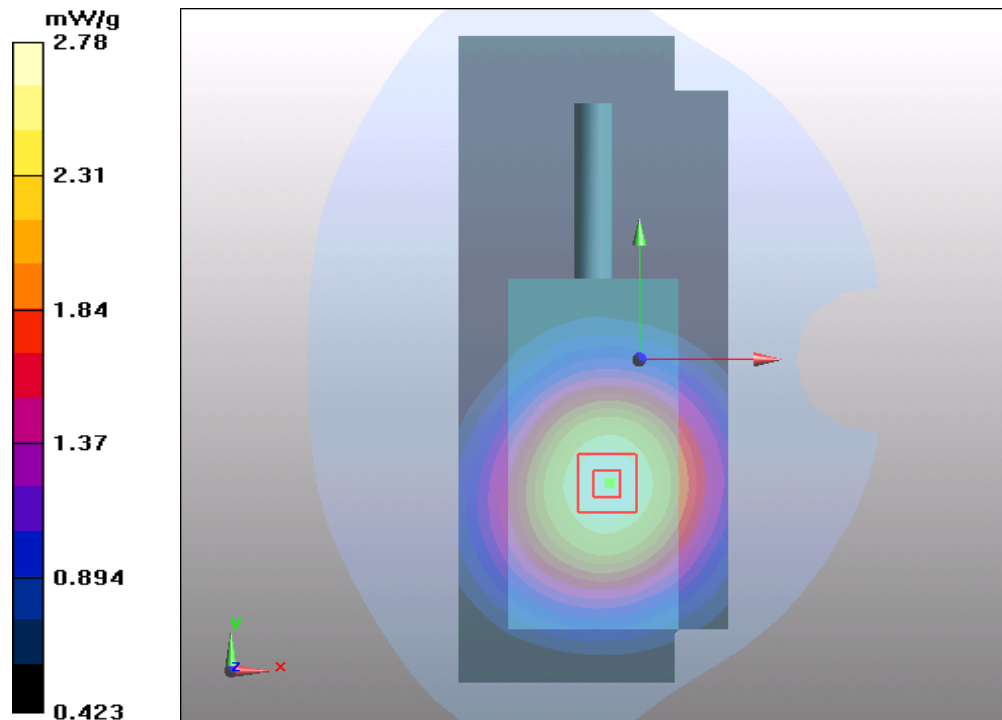

Figure 12 Face Held, Front towards Phantom 869MHz (25 KHz Channel Spacing)

TA Technology (Shanghai) Co., Ltd. Test Report

Report No. RZA1202-0269SAR01

Page 36 of 71

Body-Worn, Front towards Ground 817MHz (25 KHz Channel Spacing)

Date/Time: 4/8/2012 3:08:37 PM

Communication System: PTT 800; Frequency: 817 MHz; Duty Cycle: 1:1

Medium parameters used: $f = 817$ MHz; $\sigma = 0.966$ mho/m; $\epsilon_r = 54.5$; $\rho = 1000$ kg/m³

Ambient Temperature: 22.3 °C Liquid Temperature: 21.5 °C

Phantom section: Flat Section

DASY5 Configuration:

Probe: EX3DV4 - SN3816; ConvF(9.38, 9.38, 9.38) Calibrated: 10/3/2011;

Electronics: DAE4 Sn871; Calibrated: 11/22/2011

Phantom: SAM1; Type: SAM; Serial: TP-1534

Measurement SW: DASY5, V5.2 Build 162; SEMCAD X Version 14.0 Build 59

Towards Ground 817MHz/Area Scan (51x121x1): Measurement grid: dx=15mm, dy=15mm

Maximum value of SAR (interpolated) = 3.86 mW/g

Towards Ground 817MHz/Zoom Scan (7x7x7)/Cube 1: Measurement grid: dx=5mm, dy=5mm, dz=5mm

Reference Value = 52 V/m; Power Drift = 0.123 dB

Peak SAR (extrapolated) = 7.43 W/kg

SAR(1 g) = 3.82 mW/g; SAR(10 g) = 2.07 mW/g

Maximum value of SAR (measured) = 4.28 mW/g

Towards Ground 817MHz/Zoom Scan (7x7x7)/Cube 0: Measurement grid: dx=5mm, dy=5mm, dz=5mm

Reference Value = 52 V/m; Power Drift = 0.123 dB

Peak SAR (extrapolated) = 4.53 W/kg

SAR(1 g) = 3.69 mW/g; SAR(10 g) = 2.82 mW/g

Maximum value of SAR (measured) = 3.88 mW/g

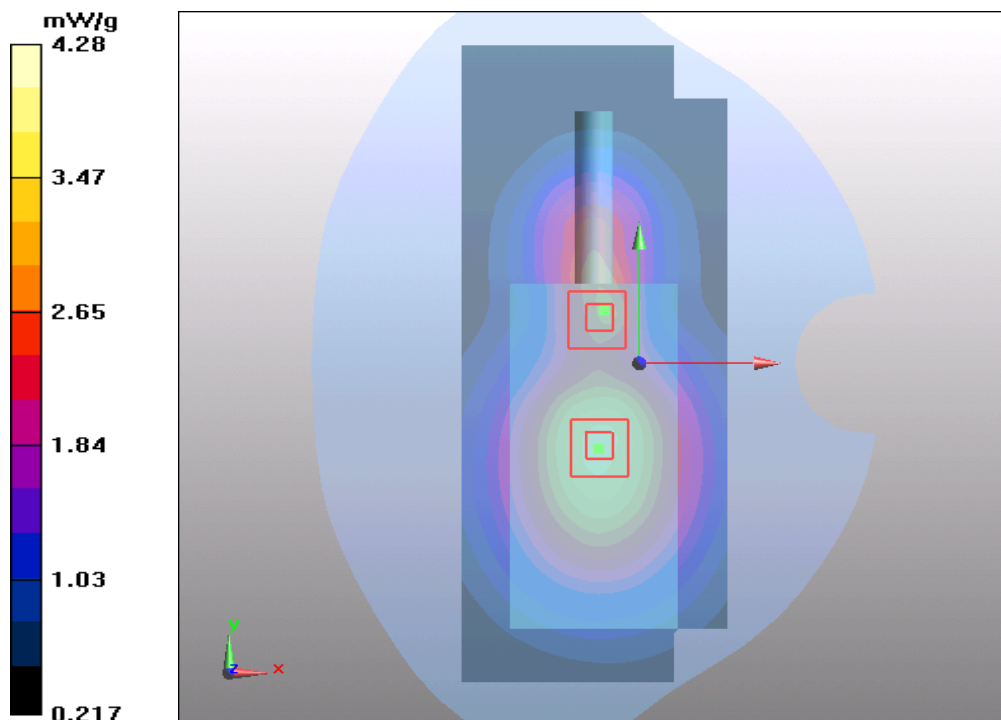

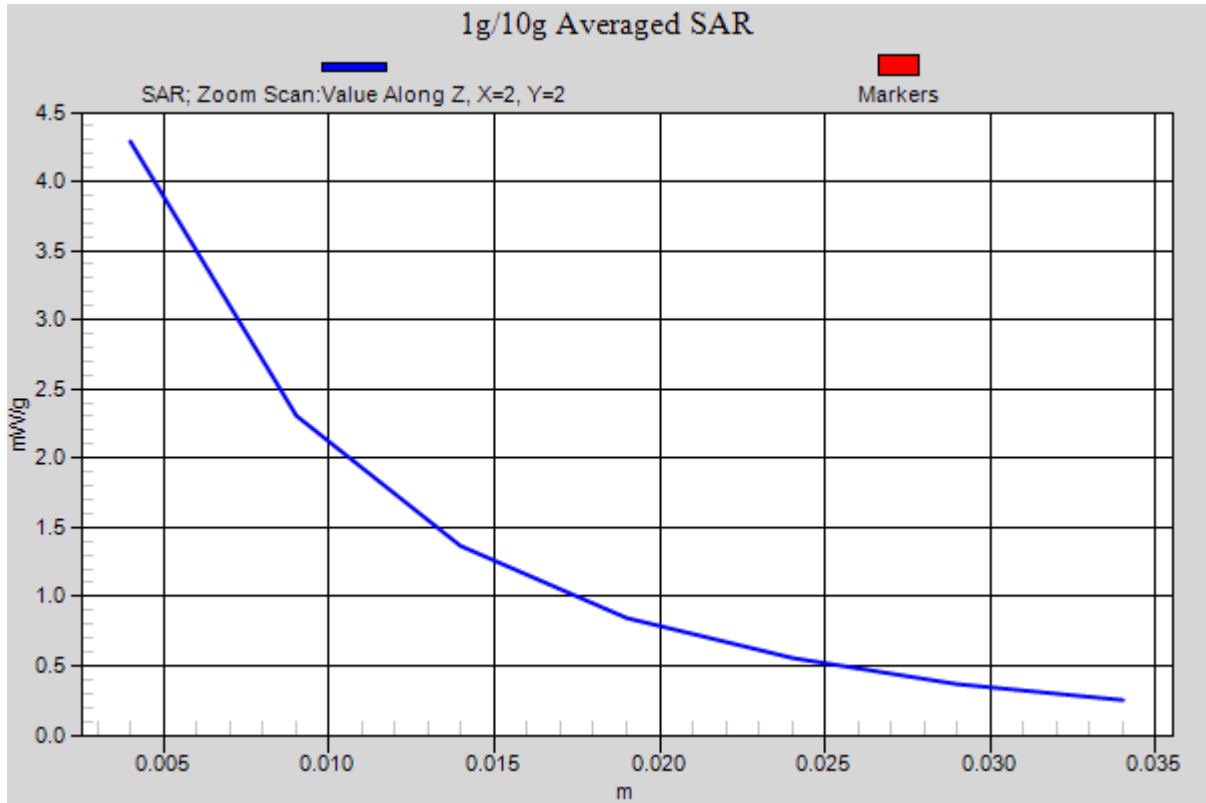

Figure 13 Body-Worn, Front towards Ground 817MHz (25 KHz Channel Spacing)

Body-Worn, Front towards Ground 824MHz (25 KHz Channel Spacing)

Date/Time: 4/8/2012 4:56:46 PM

Communication System: PTT 800; Frequency: 824 MHz; Duty Cycle: 1:1

Medium parameters used: $f = 824$ MHz; $\sigma = 0.972$ mho/m; $\epsilon_r = 54.3$; $\rho = 1000$ kg/m³

Ambient Temperature: 22.3 °C Liquid Temperature: 21.5 °C

Phantom section: Flat Section

DASY5 Configuration:

Probe: EX3DV4 - SN3816; ConvF(9.38, 9.38, 9.38) Calibrated: 10/3/2011;

Electronics: DAE4 Sn871; Calibrated: 11/22/2011

Phantom: SAM1; Type: SAM; Serial: TP-1534

Measurement SW: DASY5, V5.2 Build 162; SEMCAD X Version 14.0 Build 59

Towards Ground 824MHz/Area Scan (51x121x1): Measurement grid: dx=15mm, dy=15mm

Maximum value of SAR (interpolated) = 3.59 mW/g

Towards Ground 824MHz/Zoom Scan (7x7x7)/Cube 1: Measurement grid: dx=5mm, dy=5mm, dz=5mm

Reference Value = 50.1 V/m; Power Drift = 0.098 dB

Peak SAR (extrapolated) = 7.55 W/kg

SAR(1 g) = 3.84 mW/g; SAR(10 g) = 2.06 mW/g

Maximum value of SAR (measured) = 4.51 mW/g

Towards Ground 824MHz/Zoom Scan (7x7x7)/Cube 0: Measurement grid: dx=5mm, dy=5mm, dz=5mm

Reference Value = 50.1 V/m; Power Drift = 0.098 dB

Peak SAR (extrapolated) = 4.19 W/kg

SAR(1 g) = 3.43 mW/g; SAR(10 g) = 2.61 mW/g

Maximum value of SAR (measured) = 3.6 mW/g

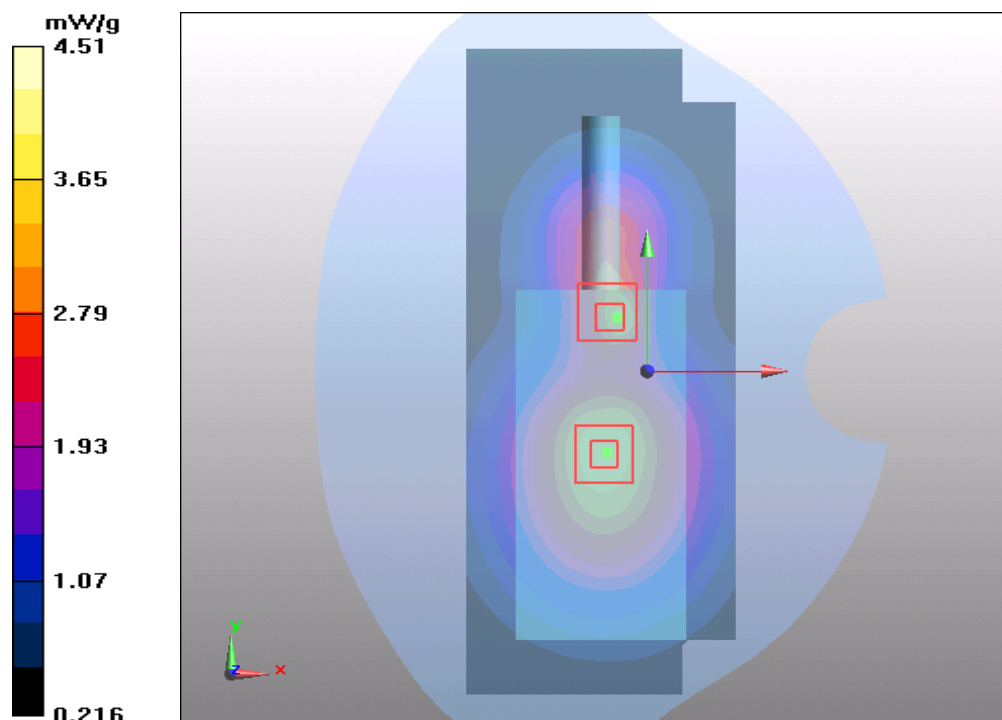

Figure 14 Body-Worn, Front towards Ground 824MHz (25 KHz Channel Spacing)

Body-Worn, Front towards Ground 862MHz (25 KHz Channel Spacing)

Date/Time: 4/8/2012 9:34:14 PM

Communication System: PTT 800; Frequency: 862 MHz; Duty Cycle: 1:1

Medium parameters used: $f = 862$ MHz; $\sigma = 1.02$ mho/m; $\epsilon_r = 54$; $\rho = 1000$ kg/m³

Ambient Temperature: 22.3 °C Liquid Temperature: 21.5°C

Phantom section: Flat Section

DASY5 Configuration:

Probe: EX3DV4 - SN3816; ConvF(9.38, 9.38, 9.38) Calibrated: 10/3/2011;

Electronics: DAE4 Sn871; Calibrated: 11/22/2011

Phantom: SAM1; Type: SAM; Serial: TP-1534

Measurement SW: DASY5, V5.2 Build 162; SEMCAD X Version 14.0 Build 59

Towards Ground 862MHz/Area Scan (51x121x1): Measurement grid: dx=15mm, dy=15mm

Maximum value of SAR (interpolated) = 2.75 mW/g

Towards Ground 862MHz/Zoom Scan (7x7x7)/Cube 1: Measurement grid: dx=5mm, dy=5mm, dz=5mm

Reference Value = 36.8 V/m; Power Drift = -0.051 dB

Peak SAR (extrapolated) = 2.45 W/kg

SAR(1 g) = 1.99 mW/g; SAR(10 g) = 1.5 mW/g

Maximum value of SAR (measured) = 2.09 mW/g

Towards Ground 862MHz/Zoom Scan (7x7x7)/Cube 0: Measurement grid: dx=5mm, dy=5mm, dz=5mm

Reference Value = 36.8 V/m; Power Drift = -0.051 dB

Peak SAR (extrapolated) = 3.25 W/kg

SAR(1 g) = 2.48 mW/g; SAR(10 g) = 1.75 mW/g

Maximum value of SAR (measured) = 2.65 mW/g

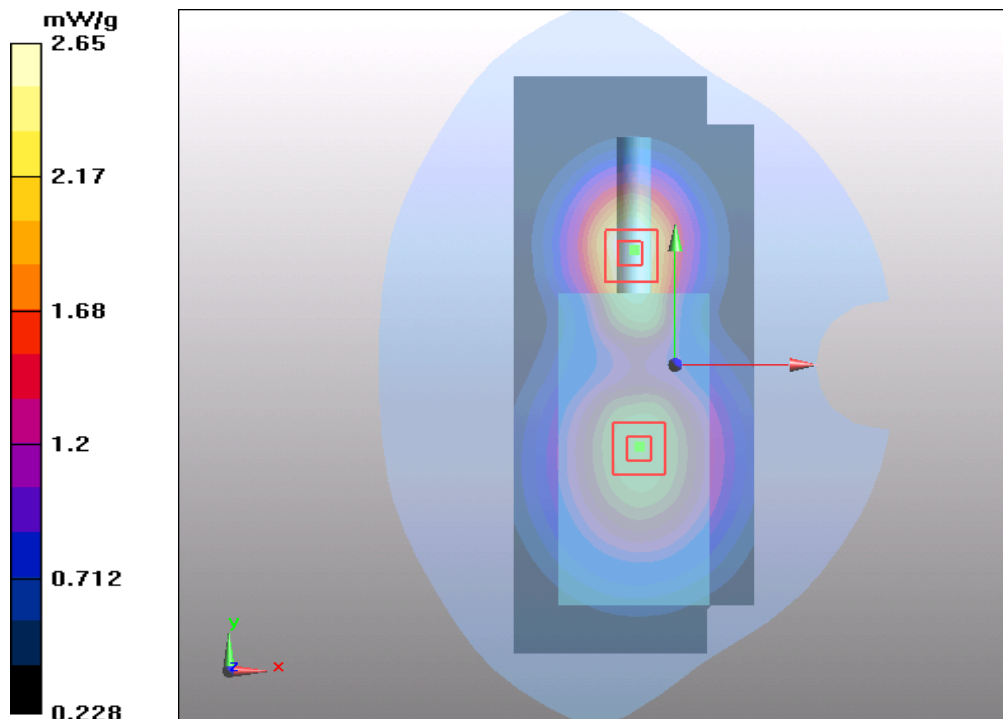

Figure 15 Body-Worn, Front towards Ground 862MHz (25 KHz Channel Spacing)

Body-Worn, Front towards Ground 869MHz (25 KHz Channel Spacing)

Date/Time: 4/8/2012 8:12:33 PM

Communication System: PTT 800; Frequency: 869 MHz; Duty Cycle: 1:1

Medium parameters used: $f = 869$ MHz; $\sigma = 1.02$ mho/m; $\epsilon_r = 54.5$; $\rho = 1000$ kg/m³

Ambient Temperature: 22.3 °C Liquid Temperature: 21.5 °C

Phantom section: Flat Section

DASY5 Configuration:

Probe: EX3DV4 - SN3816; ConvF(9.38, 9.38, 9.38) Calibrated: 10/3/2011;

Electronics: DAE4 Sn871; Calibrated: 11/22/2011

Phantom: SAM1; Type: SAM; Serial: TP-1534

Measurement SW: DASY5, V5.2 Build 162; SEMCAD X Version 14.0 Build 59

Towards Ground 869MHz/Area Scan (51x121x1): Measurement grid: dx=15mm, dy=15mm

Maximum value of SAR (interpolated) = 2.64 mW/g

Towards Ground 869MHz/Zoom Scan (7x7x7)/Cube 0: Measurement grid: dx=5mm, dy=5mm, dz=5mm

Reference Value = 30.8 V/m; Power Drift = -0.005 dB

Peak SAR (extrapolated) = 3.44 W/kg

SAR(1 g) = 2.31 mW/g; SAR(10 g) = 1.63 mW/g

Maximum value of SAR (measured) = 2.53 mW/g

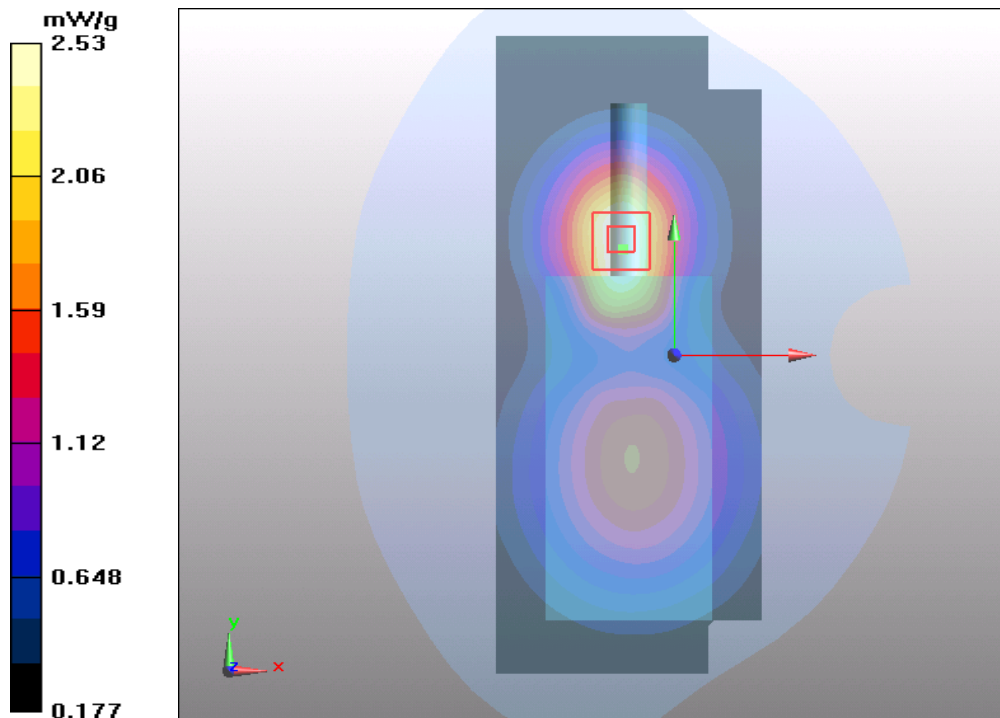

Figure 16 Body-Worn, Front towards Ground 869MHz (25 KHz Channel Spacing)

TA Technology (Shanghai) Co., Ltd. Test Report

Report No. RZA1202-0269SAR01

Page 41 of 71

ANNEX D: Probe Calibration Certificate

**Calibration Laboratory of
Schmid & Partner
Engineering AG**
Zeughausstrasse 43, 8004 Zurich, Switzerland



S Schweizerischer Kalibrierdienst
C Service suisse d'étalonnage
S Servizio svizzero di taratura
S Swiss Calibration Service

Accredited by the Swiss Accreditation Service (SAS)
The Swiss Accreditation Service is one of the signatories to the EA
Multilateral Agreement for the recognition of calibration certificates

Accreditation No.: **SCS 108**

Client **TMC Shanghai (Auden)**

Certificate No: **EX3-3816_Oct11**

CALIBRATION CERTIFICATE

Object **EX3DV4 - SN:3816**

Calibration procedure(s) **QA CAL-01.v8, QA CAL-12.v7, QA CAL-23.v4, QA CAL-25.v4
Calibration procedure for dosimetric E-field probes**

Calibration date: **October 3, 2011**

This calibration certificate documents the traceability to national standards, which realize the physical units of measurements (SI).
The measurements and the uncertainties with confidence probability are given on the following pages and are part of the certificate.

All calibrations have been conducted in the closed laboratory facility: environment temperature (22 ± 3)°C and humidity < 70%.

Calibration Equipment used (M&TE critical for calibration)

Primary Standards	ID	Cal Date (Certificate No.)	Scheduled Calibration
Power meter E4419B	GB41293874	31-Mar-11 (No. 217-01372)	Apr-12
Power sensor E4412A	MY41498087	31-Mar-11 (No. 217-01372)	Apr-12
Reference 3 dB Attenuator	SN: S5054 (3c)	29-Mar-11 (No. 217-01389)	Apr-12
Reference 20 dB Attenuator	SN: S5086 (20b)	29-Mar-11 (No. 217-01367)	Apr-12
Reference 30 dB Attenuator	SN: S5129 (30b)	29-Mar-11 (No. 217-01370)	Apr-12
Reference Probe ES3DV2	SN: 3013	29-Dec-10 (No. ES3-3013_Dec10)	Dec-11
DAE4	SN: 654	3-May-11 (No. DAE4-654_May11)	May-12
Secondary Standards	ID	Check Date (In house)	Scheduled Check
RF generator HP 8648C	US3642U01700	4-Aug-99 (in house check Oct-09)	In house check: Oct-11
Network Analyzer HP 8753E	US37390585	18-Oct-01 (in house check Oct-10)	In house check: Oct-11

	Name	Function	Signature
Calibrated by:	Jeton Kastrati	Laboratory Technician	
Approved by:	Katja Pokovic	Technical Manager	
			Issued: October 3, 2011

This calibration certificate shall not be reproduced except in full without written approval of the laboratory.

TA Technology (Shanghai) Co., Ltd.

Test Report

Report No. RZA1202-0269SAR01

Page 42 of 71

Calibration Laboratory of
Schmid & Partner
Engineering AG
Zeughausstrasse 43, 8004 Zurich, Switzerland



S Schweizerischer Kalibrierdienst
C Service suisse d'étalonnage
S Servizio svizzero di taratura
S Swiss Calibration Service

Accredited by the Swiss Accreditation Service (SAS)
The Swiss Accreditation Service is one of the signatories to the EA
Multilateral Agreement for the recognition of calibration certificates

Accreditation No.: **SCS 108**

Glossary:

TSL	tissue simulating liquid
NORM _{x,y,z}	sensitivity in free space
ConvF	sensitivity in TSL / NORM _{x,y,z}
DCP	diode compression point
CF	crest factor (1/duty_cycle) of the RF signal
A, B, C	modulation dependent linearization parameters
Polarization φ	φ rotation around probe axis
Polarization ϑ	ϑ rotation around an axis that is in the plane normal to probe axis (at measurement center), i.e., $\vartheta = 0$ is normal to probe axis

Calibration is Performed According to the Following Standards:

- IEEE Std 1528-2003, "IEEE Recommended Practice for Determining the Peak Spatial-Averaged Specific Absorption Rate (SAR) in the Human Head from Wireless Communications Devices: Measurement Techniques", December 2003
- IEC 62209-1, "Procedure to measure the Specific Absorption Rate (SAR) for hand-held devices used in close proximity to the ear (frequency range of 300 MHz to 3 GHz)", February 2005

Methods Applied and Interpretation of Parameters:

- NORM_{x,y,z}**: Assessed for E-field polarization $\vartheta = 0$ ($f \leq 900$ MHz in TEM-cell; $f > 1800$ MHz: R22 waveguide). NORM_{x,y,z} are only intermediate values, i.e., the uncertainties of NORM_{x,y,z} does not affect the E^2 -field uncertainty inside TSL (see below ConvF).
- NORM(f)_{x,y,z}** = NORM_{x,y,z} * frequency_response (see Frequency Response Chart). This linearization is implemented in DASY4 software versions later than 4.2. The uncertainty of the frequency response is included in the stated uncertainty of ConvF.
- DCP_{x,y,z}**: DCP are numerical linearization parameters assessed based on the data of power sweep with CW signal (no uncertainty required). DCP does not depend on frequency nor media.
- PAR**: PAR is the Peak to Average Ratio that is not calibrated but determined based on the signal characteristics
- A_{x,y,z}; B_{x,y,z}; C_{x,y,z}; VR_{x,y,z}**: A, B, C are numerical linearization parameters assessed based on the data of power sweep for specific modulation signal. The parameters do not depend on frequency nor media. VR is the maximum calibration range expressed in RMS voltage across the diode.
- ConvF and Boundary Effect Parameters**: Assessed in flat phantom using E-field (or Temperature Transfer Standard for $f \leq 800$ MHz) and inside waveguide using analytical field distributions based on power measurements for $f > 800$ MHz. The same setups are used for assessment of the parameters applied for boundary compensation (alpha, depth) of which typical uncertainty values are given. These parameters are used in DASY4 software to improve probe accuracy close to the boundary. The sensitivity in TSL corresponds to NORM_{x,y,z} * ConvF whereby the uncertainty corresponds to that given for ConvF. A frequency dependent ConvF is used in DASY version 4.4 and higher which allows extending the validity from ± 50 MHz to ± 100 MHz.
- Spherical isotropy (3D deviation from isotropy)**: in a field of low gradients realized using a flat phantom exposed by a patch antenna.
- Sensor Offset**: The sensor offset corresponds to the offset of virtual measurement center from the probe tip (on probe axis). No tolerance required.

EX3DV4 – SN:3816

October 3, 2011

Probe EX3DV4

SN:3816

Manufactured: September 2, 2011
Calibrated: October 3, 2011

Calibrated for DASY/EASY Systems
(Note: non-compatible with DASY2 system!)

TA Technology (Shanghai) Co., Ltd.

Test Report

EX3DV4- SN:3816

October 3, 2011

DASY/EASY - Parameters of Probe: EX3DV4 - SN:3816

Basic Calibration Parameters

	Sensor X	Sensor Y	Sensor Z	Unc (k=2)
Norm ($\mu\text{V}/(\text{V}/\text{m})^{\text{E}^{\text{A}}}$)	0.48	0.56	0.61	$\pm 10.1 \%$
DCP (mV) ^B	99.8	102.2	102.1	

Modulation Calibration Parameters

UID	Communication System Name	PAR		A dB	B dB	C dB	VR mV	Unc ^E (k=2)
10000	CW	0.00	X	0.00	0.00	1.00	111.3	$\pm 2.7 \%$
			Y	0.00	0.00	1.00	127.3	
			Z	0.00	0.00	1.00	127.7	

The reported uncertainty of measurement is stated as the standard uncertainty of measurement multiplied by the coverage factor $k=2$, which for a normal distribution corresponds to a coverage probability of approximately 95%.

^A The uncertainties of NormX,Y,Z do not affect the E²-field uncertainty inside TSL (see Pages 5 and 6).

^B Numerical linearization parameter: uncertainty not required.

^E Uncertainty is determined using the max. deviation from linear response applying rectangular distribution and is expressed for the square of the field value.

EX3DV4- SN:3816

October 3, 2011

DASY/EASY - Parameters of Probe: EX3DV4 - SN:3816

Calibration Parameter Determined in Head Tissue Simulating Media

f (MHz) ^c	Relative Permittivity ^f	Conductivity (S/m) ^f	ConvF X	ConvF Y	ConvF Z	Alpha	Depth (mm)	Unct. (k=2)
450	43.5	0.87	9.97	9.97	9.97	0.11	1.00	± 13.4 %
750	41.9	0.89	9.47	9.47	9.47	0.62	0.78	± 12.0 %
835	41.5	0.90	9.22	9.22	9.22	0.76	0.66	± 12.0 %
1450	40.5	1.20	8.58	8.58	8.58	0.65	0.77	± 12.0 %
1750	40.1	1.37	8.23	8.23	8.23	0.80	0.58	± 12.0 %
1900	40.0	1.40	7.90	7.90	7.90	0.80	0.57	± 12.0 %
2450	39.2	1.80	7.17	7.17	7.17	0.66	0.64	± 12.0 %
2600	39.0	1.96	7.06	7.06	7.06	0.64	0.67	± 12.0 %

^c Frequency validity of ± 100 MHz only applies for DASY v4.4 and higher (see Page 2), else it is restricted to ± 50 MHz. The uncertainty is the RSS of the ConvF uncertainty at calibration frequency and the uncertainty for the indicated frequency band.

^f At frequencies below 3 GHz, the validity of tissue parameters (ϵ and σ) can be relaxed to ± 10% if liquid compensation formula is applied to measured SAR values. At frequencies above 3 GHz, the validity of tissue parameters (ϵ and σ) is restricted to ± 5%. The uncertainty is the RSS of the ConvF uncertainty for indicated target tissue parameters.

EX3DV4- SN:3816

October 3, 2011

DASY/EASY - Parameters of Probe: EX3DV4 - SN:3816

Calibration Parameter Determined in Body Tissue Simulating Media

f (MHz) ^C	Relative Permittivity ^F	Conductivity (S/m) ^F	ConvF X	ConvF Y	ConvF Z	Alpha	Depth (mm)	Unct. (k=2)
450	56.7	0.94	10.83	10.83	10.83	0.02	1.00	± 13.4 %
750	55.5	0.96	9.50	9.50	9.50	0.80	0.70	± 12.0 %
835	55.2	0.97	9.38	9.38	9.38	0.68	0.69	± 12.0 %
1750	53.4	1.49	7.80	7.80	7.80	0.80	0.65	± 12.0 %
1900	53.3	1.52	7.51	7.51	7.51	0.80	0.65	± 12.0 %
2450	52.7	1.95	7.19	7.19	7.19	0.80	0.60	± 12.0 %
2600	52.5	2.16	7.14	7.14	7.14	0.80	0.59	± 12.0 %

^C Frequency validity of ± 100 MHz only applies for DASY v4.4 and higher (see Page 2), else it is restricted to ± 50 MHz. The uncertainty is the RSS of the ConvF uncertainty at calibration frequency and the uncertainty for the indicated frequency band.

^F At frequencies below 3 GHz, the validity of tissue parameters (ϵ and σ) can be relaxed to ± 10% if liquid compensation formula is applied to measured SAR values. At frequencies above 3 GHz, the validity of tissue parameters (ϵ and σ) is restricted to ± 5%. The uncertainty is the RSS of the ConvF uncertainty for indicated target tissue parameters.

EX3DV4- SN:3816

October 3, 2011

Frequency Response of E-Field (TEM-Cell: ifi110 EXX, Waveguide: R22)

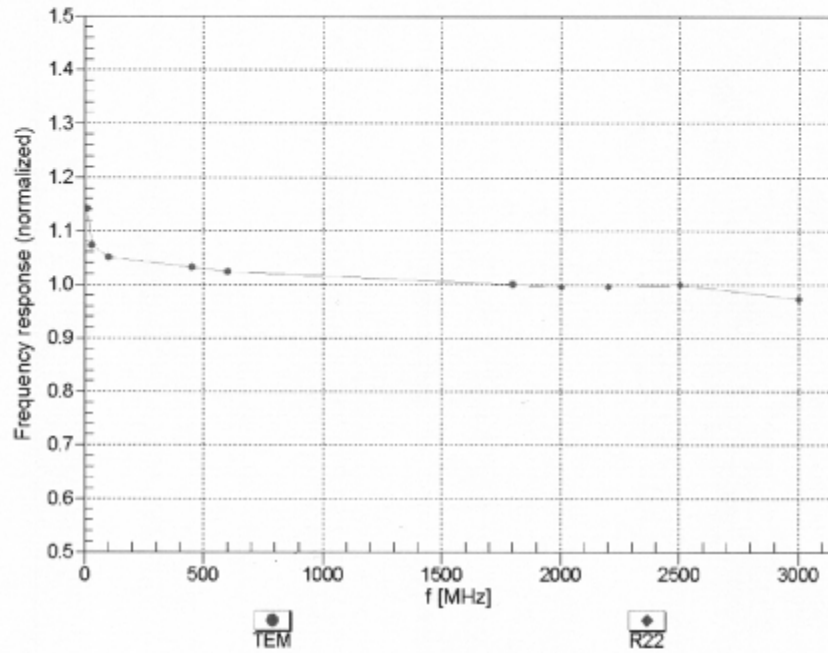

Uncertainty of Frequency Response of E-field: $\pm 6.3\%$ (k=2)

EX3DV4-SN:3816

October 3, 2011

Receiving Pattern (ϕ), $\theta = 0^\circ$

f=600 MHz,TEM

f=1800 MHz,R22

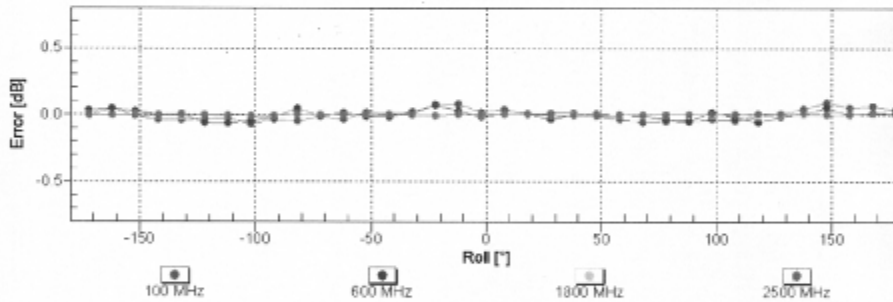
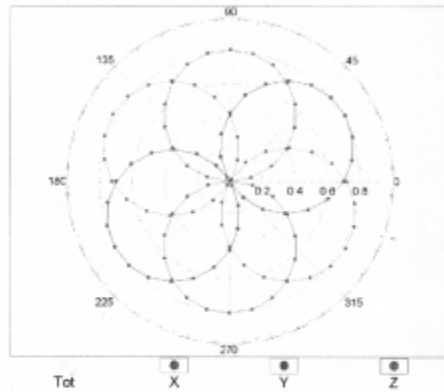
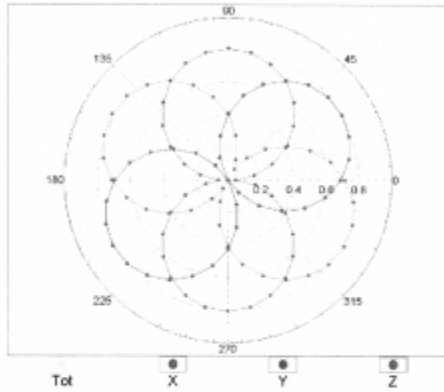

Uncertainty of Axial Isotropy Assessment: $\pm 0.5\%$ (k=2)

EX3DV4- SN:3816

October 3, 2011

Dynamic Range f(SAR_{head})
 (TEM cell , f = 900 MHz)

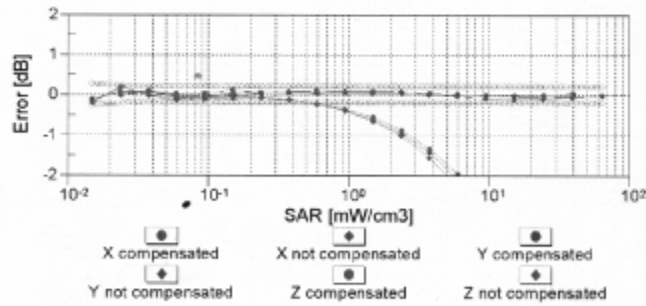
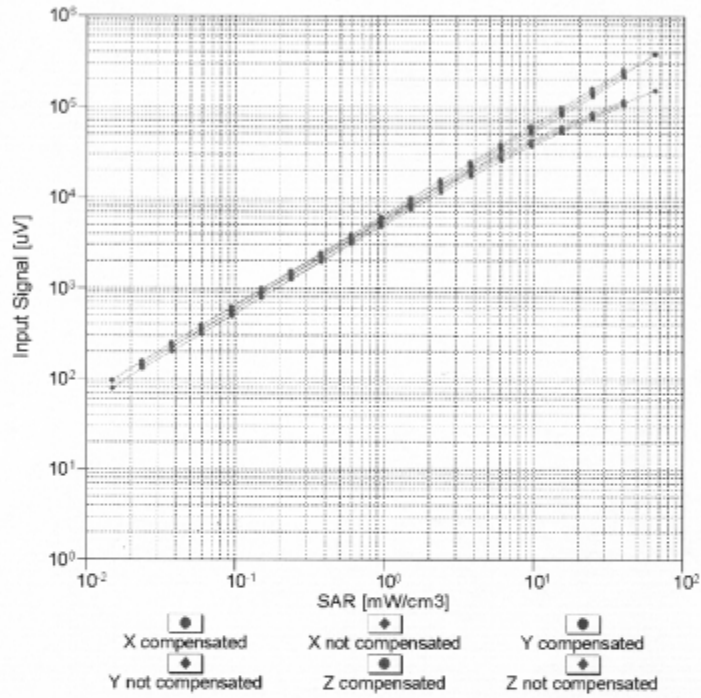

Uncertainty of Linearity Assessment: ± 0.6% (k=2)

EX3DV4- SN:3816

October 3, 2011

Conversion Factor Assessment

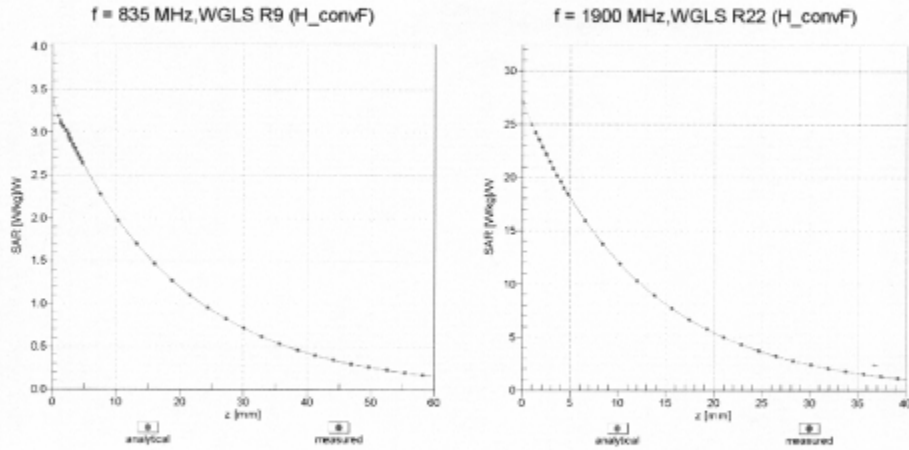

Deviation from Isotropy in Liquid Error (ϕ, θ), f = 900 MHz

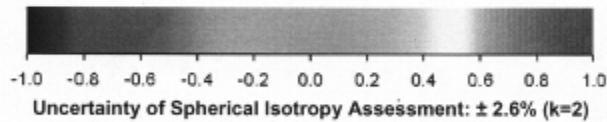
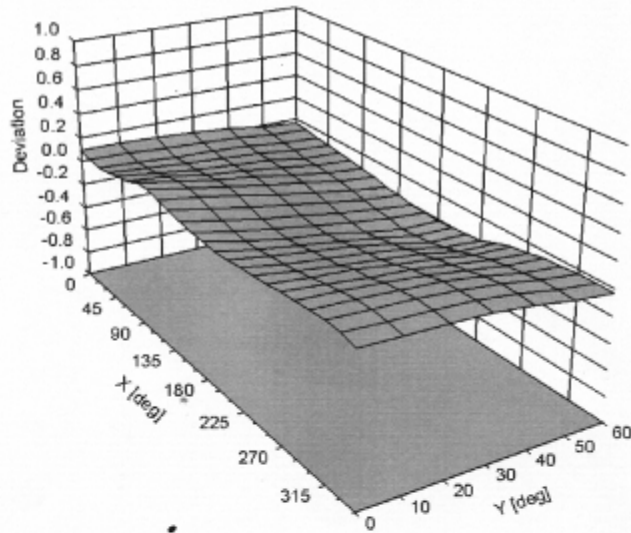

TA Technology (Shanghai) Co., Ltd.
Test Report

Report No. RZA1202-0269SAR01

Page 51 of 71

EX3DV4- SN:3816

October 3, 2011

DASY/EASY - Parameters of Probe: EX3DV4 - SN:3816

Other Probe Parameters

Sensor Arrangement	Triangular
Connector Angle (°)	Not applicable
Mechanical Surface Detection Mode	enabled
Optical Surface Detection Mode	disabled
Probe Overall Length	337 mm
Probe Body Diameter	10 mm
Tip Length	9 mm
Tip Diameter	2.5 mm
Probe Tip to Sensor X Calibration Point	1 mm
Probe Tip to Sensor Y Calibration Point	1 mm
Probe Tip to Sensor Z Calibration Point	1 mm
Recommended Measurement Distance from Surface	2 mm

TA Technology (Shanghai) Co., Ltd.

Test Report

Report No. RZA1202-0269SAR01

Page 52 of 71

ANNEX E: D835V2 Dipole Calibration Certificate

**Calibration Laboratory of
Schmid & Partner
Engineering AG**
Zeughausstrasse 43, 8004 Zurich, Switzerland



S Schweizerischer Kalibrierdienst
C Service suisse d'étalonnage
S Servizio svizzero di taratura
S Swiss Calibration Service

Accredited by the Swiss Accreditation Service (SAS)
The Swiss Accreditation Service is one of the signatories to the EA
Multilateral Agreement for the recognition of calibration certificates

Accreditation No.: **SCS 108**

Client **TA-Shanghai (Auden)**

Certificate No: **D835V2-4d020_Aug11**

CALIBRATION CERTIFICATE																																															
Object	D835V2 - SN: 4d020																																														
Calibration procedure(s)	QA CAL-05.v8 Calibration procedure for dipole validation kits above 700 MHz																																														
Calibration date:	August 26, 2011																																														
<p>This calibration certificate documents the traceability to national standards, which realize the physical units of measurements (SI). The measurements and the uncertainties with confidence probability are given on the following pages and are part of the certificate.</p> <p>All calibrations have been conducted in the closed laboratory facility: environment temperature (22 ± 3)°C and humidity < 70%.</p> <p>Calibration Equipment used (M&TE critical for calibration)</p> <table border="1" style="width: 100%; border-collapse: collapse;"> <thead> <tr> <th style="width: 30%;">Primary Standards</th> <th style="width: 15%;">ID #</th> <th style="width: 35%;">Cal Date (Certificate No.)</th> <th style="width: 20%;">Scheduled Calibration</th> </tr> </thead> <tbody> <tr> <td>Power meter EPM-442A</td> <td>GB37480704</td> <td>06-Oct-10 (No. 217-01266)</td> <td>Oct-11</td> </tr> <tr> <td>Power sensor HP 8481A</td> <td>US37292783</td> <td>06-Oct-10 (No. 217-01266)</td> <td>Oct-11</td> </tr> <tr> <td>Reference 20 dB Attenuator</td> <td>SN: S5086 (20b)</td> <td>29-Mar-11 (No. 217-01367)</td> <td>Apr-12</td> </tr> <tr> <td>Type-N mismatch combination</td> <td>SN: 5047.2 / 06327</td> <td>29-Mar-11 (No. 217-01371)</td> <td>Apr-12</td> </tr> <tr> <td>Reference Probe ES3DV3</td> <td>SN: 3205</td> <td>29-Apr-11 (No. ES3-3205_Apr11)</td> <td>Apr-12</td> </tr> <tr> <td>DAE4</td> <td>SN: 601</td> <td>04-Jul-11 (No. DAE4-601_Jul11)</td> <td>Jul-12</td> </tr> </tbody> </table> <table border="1" style="width: 100%; border-collapse: collapse;"> <thead> <tr> <th style="width: 30%;">Secondary Standards</th> <th style="width: 15%;">ID #</th> <th style="width: 35%;">Check Date (in house)</th> <th style="width: 20%;">Scheduled Check</th> </tr> </thead> <tbody> <tr> <td>Power sensor HP 8481A</td> <td>MY41092317</td> <td>18-Oct-02 (in house check Oct-09)</td> <td>In house check: Oct-11</td> </tr> <tr> <td>RF generator R&S SMT-06</td> <td>100005</td> <td>04-Aug-99 (in house check Oct-09)</td> <td>In house check: Oct-11</td> </tr> <tr> <td>Network Analyzer HP 8753E</td> <td>US37390585 S4206</td> <td>18-Oct-01 (in house check Oct-10)</td> <td>In house check: Oct-11</td> </tr> </tbody> </table>				Primary Standards	ID #	Cal Date (Certificate No.)	Scheduled Calibration	Power meter EPM-442A	GB37480704	06-Oct-10 (No. 217-01266)	Oct-11	Power sensor HP 8481A	US37292783	06-Oct-10 (No. 217-01266)	Oct-11	Reference 20 dB Attenuator	SN: S5086 (20b)	29-Mar-11 (No. 217-01367)	Apr-12	Type-N mismatch combination	SN: 5047.2 / 06327	29-Mar-11 (No. 217-01371)	Apr-12	Reference Probe ES3DV3	SN: 3205	29-Apr-11 (No. ES3-3205_Apr11)	Apr-12	DAE4	SN: 601	04-Jul-11 (No. DAE4-601_Jul11)	Jul-12	Secondary Standards	ID #	Check Date (in house)	Scheduled Check	Power sensor HP 8481A	MY41092317	18-Oct-02 (in house check Oct-09)	In house check: Oct-11	RF generator R&S SMT-06	100005	04-Aug-99 (in house check Oct-09)	In house check: Oct-11	Network Analyzer HP 8753E	US37390585 S4206	18-Oct-01 (in house check Oct-10)	In house check: Oct-11
Primary Standards	ID #	Cal Date (Certificate No.)	Scheduled Calibration																																												
Power meter EPM-442A	GB37480704	06-Oct-10 (No. 217-01266)	Oct-11																																												
Power sensor HP 8481A	US37292783	06-Oct-10 (No. 217-01266)	Oct-11																																												
Reference 20 dB Attenuator	SN: S5086 (20b)	29-Mar-11 (No. 217-01367)	Apr-12																																												
Type-N mismatch combination	SN: 5047.2 / 06327	29-Mar-11 (No. 217-01371)	Apr-12																																												
Reference Probe ES3DV3	SN: 3205	29-Apr-11 (No. ES3-3205_Apr11)	Apr-12																																												
DAE4	SN: 601	04-Jul-11 (No. DAE4-601_Jul11)	Jul-12																																												
Secondary Standards	ID #	Check Date (in house)	Scheduled Check																																												
Power sensor HP 8481A	MY41092317	18-Oct-02 (in house check Oct-09)	In house check: Oct-11																																												
RF generator R&S SMT-06	100005	04-Aug-99 (in house check Oct-09)	In house check: Oct-11																																												
Network Analyzer HP 8753E	US37390585 S4206	18-Oct-01 (in house check Oct-10)	In house check: Oct-11																																												
Calibrated by:	Name Jeton Kastrati	Function Laboratory Technician	Signature 																																												
Approved by:	Name Katja Pokovic	Function Technical Manager	Signature 																																												
			Issued: August 26, 2011																																												
This calibration certificate shall not be reproduced except in full without written approval of the laboratory.																																															