



FCC TEST REPORT (15.407)

REPORT NO.: RF130107C12-1

MODEL NO.: TEW-805UB

FCC ID: XU8TEW805UB

RECEIVED: Jan. 07, 2013

TESTED: Jan. 10 ~ Jan. 15, 2013

ISSUED: Feb. 25, 2013

APPLICANT: TRENDNET, Inc.

ADDRESS: 20675 Manhattan Place, Torrance, CA 90501,
USA

ISSUED BY: Bureau Veritas Consumer Products Services
(H.K.) Ltd., Taoyuan Branch

LAB ADDRESS: No. 47, 14th Ling, Chia Pau Vil., Lin Kou Dist.,
New Taipei City, Taiwan, R.O.C.

TEST LOCATION: No. 19, Hwa Ya 2nd Rd, Wen Hwa Tsuen, Kwei
Shan Hsiang, Taoyuan Hsien 333, Taiwan, R.O.C.

This report should not be used by the client to claim product certification, approval, or endorsement by TAF or any government agencies.



This report is for your exclusive use. Any copying or replication of this report to or for any other person or entity, or use of our name or trademark, is permitted only with our prior written permission. This report sets forth our findings solely with respect to the test samples identified herein. The results set forth in this report are not indicative or representative of the quality or characteristics of the lot from which a test sample was taken or any similar or identical product unless specifically and expressly noted. Our report includes all of the tests requested by you and the results thereof based upon the information that you provided to us. You have 60 days from date of issuance of this report to notify us of any material error or omission caused by our negligence, provided, however, that such notice shall be in writing and shall specifically address the issue you wish to raise. A failure to raise such issue within the prescribed time shall constitute your unqualified acceptance of the completeness of this report, the tests conducted and the correctness of the report contents. Unless specific mention, the uncertainty of measurement has been explicitly taken into account to declare the compliance or non-compliance to the specification.



TABLE OF CONTENTS

RELEASE CONTROL RECORD.....	4
1. CERTIFICATION.....	5
2. SUMMARY OF TEST RESULTS.....	6
2.1 MEASUREMENT UNCERTAINTY.....	6
3. GENERAL INFORMATION.....	7
3.1 GENERAL DESCRIPTION OF EUT.....	7
3.2 DESCRIPTION OF TEST MODES.....	9
3.2.1 TEST MODE APPLICABILITY AND TESTED CHANNEL DETAIL.....	11
3.3 DUTY CYCLE OF TEST SIGNAL.....	13
3.4 DESCRIPTION OF SUPPORT UNITS.....	14
3.4.1 CONFIGURATION OF SYSTEM UNDER TEST.....	14
3.5 GENERAL DESCRIPTION OF APPLIED STANDARDS.....	15
4. TEST TYPES AND RESULTS.....	16
4.1 RADIATED EMISSION AND BANDEDGE MEASUREMENT.....	16
4.1.1 LIMITS OF RADIATED EMISSION AND BANDEDGE MEASUREMENT.....	16
4.1.2 LIMITS OF UNWANTED EMISSION OUT OF THE RESTRICTED BANDS.....	16
4.1.3 TEST INSTRUMENTS.....	17
4.1.4 TEST PROCEDURES.....	18
4.1.5 DEVIATION FROM TEST STANDARD.....	18
4.1.6 TEST SETUP.....	19
4.1.7 EUT OPERATING CONDITIONS.....	19
4.1.8 TEST RESULTS.....	20
4.2 CONDUCTED EMISSION MEASUREMENT.....	50
4.2.1 LIMITS OF CONDUCTED EMISSION MEASUREMENT.....	50
4.2.2 TEST INSTRUMENTS.....	50
4.2.3 TEST PROCEDURES.....	51
4.2.4 DEVIATION FROM TEST STANDARD.....	51
4.2.5 TEST SETUP.....	51
4.2.6 EUT OPERATING CONDITIONS.....	51
4.2.7 TEST RESULTS.....	52
4.3 PEAK TRANSMIT POWER MEASUREMENT.....	56
4.3.1 LIMITS OF PEAK TRANSMIT POWER MEASUREMENT.....	56
4.3.2 TEST SETUP.....	56
4.3.3 TEST INSTRUMENTS.....	57
4.3.4 TEST PROCEDURE.....	57
4.3.5 DEVIATION FROM TEST STANDARD.....	58
4.3.6 EUT OPERATING CONDITIONS.....	58
4.3.7 TEST RESULTS.....	59
4.4 PEAK POWER SPECTRAL DENSITY MEASUREMENT.....	64
4.4.1 LIMITS OF PEAK POWER SPECTRAL DENSITY MEASUREMENT.....	64



A D T

4.4.2	TEST SETUP	64
4.4.3	TEST INSTRUMENTS	64
4.4.4	TEST PROCEDURES.....	64
4.4.5	DEVIATION FROM TEST STANDARD.....	64
4.4.6	EUT OPERATING CONDITIONS	64
4.4.7	TEST RESULTS.....	65
4.5	PEAK POWER EXCURSION MEASUREMENT	67
4.5.1	LIMITS OF PEAK POWER EXCURSION MEASUREMENT.....	67
4.5.2	TEST SETUP	67
4.5.3	TEST INSTRUMENTS	67
4.5.4	TEST PROCEDURE	67
4.5.5	DEVIATION FROM TEST STANDARD.....	67
4.5.6	EUT OPERATING CONDITIONS	67
4.5.7	TEST RESULTS.....	68
4.6	FREQUENCY STABILITY	72
4.6.1	LIMITS OF FREQUENCY STABILITY MEASUREMENT	72
4.6.2	TEST SETUP	72
4.6.3	TEST INSTRUMENTS	72
4.6.4	TEST PROCEDURE	73
4.6.5	DEVIATION FROM TEST STANDARD.....	73
4.6.6	EUT OPERATING CONDITION.....	73
4.6.7	TEST RESULTS.....	74
5.	PHOTOGRAPHS OF THE TEST CONFIGURATION.....	75
6.	INFORMATION ON THE TESTING LABORATORIES	76
7.	APPENDIX A – MODIFICATIONS RECORDERS FOR ENGINEERING CHANGES TO THE EUT BY THE LAB	77



A D T

RELEASE CONTROL RECORD

ISSUE NO.	REASON FOR CHANGE	DATE ISSUED
RF130107C12-1	Original release	Feb. 25, 2013



1. CERTIFICATION

PRODUCT: AC1200 Dual Band USB Adapter

MODEL: TEW-805UB

BRAND: TRENDnet

APPLICANT: TRENDNET, Inc.

TESTED: Jan. 10 ~ Jan. 15, 2013

TEST SAMPLE: ENGINEERING SAMPLE

STANDARDS: FCC Part 15, Subpart E (Section 15.407)

ANSI C63.10-2009

The above equipment (model: TEW-805UB) has been tested by **Bureau Veritas Consumer Products Services (H.K.) Ltd., Taoyuan Branch**, and found compliance with the requirement of the above standards. The test record, data evaluation & Equipment Under Test (EUT) configurations represented herein are true and accurate accounts of the measurements of the sample's EMC characteristics under the conditions specified in this report.

PREPARED BY : Ivy Lin , **DATE :** Feb. 25, 2013
Ivy Lin / Specialist

APPROVED BY : Ken Liu , **DATE :** Feb. 25, 2013
Ken Liu / Manager

2. SUMMARY OF TEST RESULTS

The EUT has been tested according to the following specifications:

APPLIED STANDARD: FCC PART 15, SUBPART E (SECTION 15.407)			
STANDARD SECTION	TEST TYPE	RESULT	REMARK
15.407(b)(6)	AC Power Conducted Emission	PASS	Meet the requirement of limit. Minimum passing margin is -12.46dB at 15.78609MHz.
15.407(b/1/2/3) (b)(6)	Spurious Emissions	PASS	Meet the requirement of limit. Minimum passing margin is -1.0dB at 15900.00MHz.
15.407(a/1/2)	Max Average Transmit Power	PASS	Meet the requirement of limit.
15.407(a)(6)	Peak Power Excursion	PASS	Meet the requirement of limit.
15.407(a/1/2)	Peak Power Spectral Density	PASS	Meet the requirement of limit.
15.407(g)	Frequency Stability	PASS	Meet the requirement of limit.
15.203	Antenna Requirement	PASS	Antenna connector is UFL not a standard connector.

2.1 MEASUREMENT UNCERTAINTY

Where relevant, the following measurement uncertainty levels have been estimated for tests performed on the EUT as specified in CISPR 16-4-2:

MEASUREMENT	FREQUENCY	UNCERTAINTY
Conducted emissions	9kHz~30MHz	2.44 dB
Radiated emissions	30MHz ~ 200MHz	2.93 dB
	200MHz ~1000MHz	2.95 dB
	1GHz ~ 18GHz	2.26 dB
	18GHz ~ 40GHz	1.94 dB

This uncertainty represents an expanded uncertainty expressed at approximately the 95% confidence level using a coverage factor of $k = 2$.

3. GENERAL INFORMATION

3.1 GENERAL DESCRIPTION OF EUT

EUT	AC1200 Dual Band USB Adapter
MODEL NO.	TEW-805UB
POWER SUPPLY	5Vdc (Host equipment)
MODULATION TYPE	64QAM, 16QAM, QPSK, BPSK 256QAM for OFDM in 11ac mode only
MODULATION TECHNOLOGY	OFDM
TRANSFER RATE	802.11a: 54/48/36/24/18/12/9/6Mbps 802.11n: up to 300Mbps 802.11ac: up to 867Mbps
OPERATING FREQUENCY	5180 ~ 5240MHz, 5260 ~ 5320MHz, 5500 ~ 5700MHz
NUMBER OF CHANNEL	5180 ~ 5240MHz: 802.11a, 802.11n (20MHz): 4 802.11n (40MHz): 2 802.11ac (80MHz): 1 5260 ~ 5320MHz: 802.11a, 802.11n (20MHz): 4 802.11n (40MHz): 2 802.11ac (80MHz): 1 5500 ~ 5700MHz: 802.11a, 802.11n (20MHz): 8 802.11n (40MHz): 3 802.11ac (80MHz): 1
OUTPUT POWER	46.909mW for 5180 ~ 5240MHz 172.020mW for 5260 ~ 5320MHz 182.827mW for 5500 ~ 5700MHz
ANTENNA TYPE	PIFA antenna with 0dBi gain
ANTENNA CONNECTOR	UFL
DATA CABLE	0.1m shielded USB cable without core
I/O PORTS	Refer to user's manual
ACCESSORY DEVICES	NA

NOTE:

1. The EUT incorporates a MIMO function. The EUT provides 2 completed transmitters and 2 receivers.

MODULATION MODE	TX FUNCTION
802.11b	1TX
802.11g	1TX
802.11a	1TX
802.11n (20MHz)	2TX
802.11n (40MHz)	2TX
802.11ac (80MHz)	2TX

2. The above EUT information is declared by manufacturer and for more detailed features description, please refer to the manufacturer's specifications or user's manual.

3.2 DESCRIPTION OF TEST MODES

FOR 5180 ~ 5240MHz

4 channels are provided for 802.11a, 802.11n (20MHz):

CHANNEL	FREQUENCY	CHANNEL	FREQUENCY
36	5180 MHz	44	5220 MHz
40	5200 MHz	48	5240 MHz

2 channels are provided for 802.11n (40MHz):

CHANNEL	FREQUENCY	CHANNEL	FREQUENCY
38	5190 MHz	46	5230 MHz

1 channel is provided for 802.11ac (80MHz):

CHANNEL	FREQUENCY
42	5210MHz

FOR 5260 ~ 5320MHz

4 channels are provided for 802.11a, 802.11n (20MHz):

CHANNEL	FREQUENCY	CHANNEL	FREQUENCY
52	5260 MHz	60	5300 MHz
56	5280 MHz	64	5320 MHz

2 channels are provided for 802.11n (40MHz):

CHANNEL	FREQUENCY	CHANNEL	FREQUENCY
54	5270 MHz	62	5310 MHz

1 channel is provided for 802.11ac (80MHz):

CHANNEL	FREQUENCY
58	5290MHz



FOR 5500 ~ 5700MHz

8 channels are provided for 802.11a, 802.11n (20MHz):

CHANNEL	FREQUENCY	CHANNEL	FREQUENCY
100	5500 MHz	116	5580 MHz
104	5520 MHz	132	5660 MHz
108	5540 MHz	136	5680 MHz
112	5560 MHz	140	5700 MHz

3 channels are provided for 802.11n (40MHz):

CHANNEL	FREQUENCY	CHANNEL	FREQUENCY
102	5510 MHz	134	5670 MHz
110	5550 MHz		

1 channel is provided for 802.11ac (80MHz):

CHANNEL	FREQUENCY
106	5530MHz

3.2.1 TEST MODE APPLICABILITY AND TESTED CHANNEL DETAIL

EUT CONFIGURE MODE	APPLICABLE TO				DESCRIPTION
	RE \geq 1G	RE $<$ 1G	PLC	APCM	
-	√	√	√	√	-

Where **RE \geq 1G**: Radiated Emission above 1GHz **RE $<$ 1G**: Radiated Emission below 1GHz
PLC: Power Line Conducted Emission **APCM**: Antenna Port Conducted Measurement

NOTE:
The EUT had been pre-tested on the positioned of each 3 axis. The worst case was found when positioned on **Z-plane**.

RADIATED EMISSION TEST (ABOVE 1GHz):

- Pre-Scan has been conducted to determine the worst-case mode from all possible combinations between available modulations, data rates and antenna ports (if EUT with antenna diversity architecture).
- Following channel(s) was (were) selected for the final test as listed below.

EUT CONFIGURE MODE	MODE	FREQ. BAND (MHz)	AVAILABLE CHANNEL	TESTED CHANNEL	MODULATION TECHNOLOGY	MODULATION TYPE	DATA RATE (Mbps)
-	802.11a	5180-5240	36 to 48	36, 40, 48	OFDM	BPSK	6.0
-	802.11n (20MHz)		36 to 48	36, 40, 48	OFDM	BPSK	7.2
-	802.11n (40MHz)		38 to 46	38, 46	OFDM	BPSK	15.0
-	802.11ac (80MHz)	5210	42	42	OFDM	BPSK	58.5
-	802.11a	5260-5320	52 to 64	52, 60, 64	OFDM	BPSK	6.0
-	802.11n (20MHz)		52 to 64	52, 60, 64	OFDM	BPSK	7.2
-	802.11n (40MHz)		54 to 62	54, 62	OFDM	BPSK	15.0
-	802.11ac (80MHz)	5290	58	58	OFDM	BPSK	58.5
-	802.11a	5500-5700	100 to 140	100, 116, 140	OFDM	BPSK	6.0
-	802.11n (20MHz)		100 to 140	100, 116, 140	OFDM	BPSK	7.2
-	802.11n (40MHz)		102 to 134	102, 110, 134	OFDM	BPSK	15.0
-	802.11ac (80MHz)	5530	106	106	OFDM	BPSK	58.5

RADIATED EMISSION TEST (BELOW 1GHz):

- Pre-Scan has been conducted to determine the worst-case mode from all possible combinations between available modulations, data rates and antenna ports (if EUT with antenna diversity architecture).
- Following channel(s) was (were) selected for the final test as listed below.

EUT CONFIGURE MODE	MODE	FREQ. BAND (MHz)	AVAILABLE CHANNEL	TESTED CHANNEL	MODULATION TECHNOLOGY	MODULATION TYPE	DATA RATE (Mbps)
-	802.11n (20MHz)	5180-5320	52 to 64	52	OFDM	BPSK	7.2
-	802.11n (40MHz)	5500-5700	102 to 134	110	OFDM	BPSK	15.0

POWER LINE CONDUCTED EMISSION TEST:

- Pre-Scan has been conducted to determine the worst-case mode from all possible combinations between available modulations, data rates and antenna ports (if EUT with antenna diversity architecture).
- Following channel(s) was (were) selected for the final test as listed below.

EUT CONFIGURE MODE	MODE	FREQ. BAND (MHz)	AVAILABLE CHANNEL	TESTED CHANNEL	MODULATION TECHNOLOGY	MODULATION TYPE	DATA RATE (Mbps)
-	802.11n (20MHz)	5180-5320	52 to 64	52	OFDM	BPSK	7.2
-	802.11n (40MHz)	5500-5700	102 to 134	110	OFDM	BPSK	15.0

ANTENNA PORT CONDUCTED MEASUREMENT:

- This item includes all test value of each mode, but only includes spectrum plot of worst value of each mode.
- Pre-Scan has been conducted to determine the worst-case mode from all possible combinations between available modulations, data rates and antenna ports (if EUT with antenna diversity architecture).
- Following channel(s) was (were) selected for the final test as listed below.

EUT CONFIGURE MODE	MODE	FREQ. BAND (MHz)	AVAILABLE CHANNEL	TESTED CHANNEL	MODULATION TECHNOLOGY	MODULATION TYPE	DATA RATE (Mbps)
-	802.11a	5180-5240	36 to 48	36, 40, 48	OFDM	BPSK	6.0
-	802.11n (20MHz)		36 to 48	36, 40, 48	OFDM	BPSK	7.2
-	802.11n (40MHz)		38 to 46	38, 46	OFDM	BPSK	15.0
-	802.11ac (80MHz)	5210	42	42	OFDM	BPSK	58.5
-	802.11a	5260-5320	52 to 64	52, 60, 64	OFDM	BPSK	6.0
-	802.11n (20MHz)		52 to 64	52, 60, 64	OFDM	BPSK	7.2
-	802.11n (40MHz)		54 to 62	54, 62	OFDM	BPSK	15.0
-	802.11ac (80MHz)	5290	58	58	OFDM	BPSK	58.5
-	802.11a	5500-5700	100 to 140	100, 116, 140	OFDM	BPSK	6.0
-	802.11n (20MHz)		100 to 140	100, 116, 140	OFDM	BPSK	7.2
-	802.11n (40MHz)		102 to 134	102, 110, 134	OFDM	BPSK	15.0
-	802.11ac (80MHz)	5530	106	106	OFDM	BPSK	58.5

TEST CONDITION:

APPLICABLE TO	ENVIRONMENTAL CONDITIONS	INPUT POWER (SYSTEM)	TESTED BY
RE≥1G	25deg. C, 68%RH	120Vac, 60Hz	Sun Lin, Martin Lee
RE<1G	25deg. C, 68%RH	120Vac, 60Hz	Sun Lin
PLC	18deg. C, 67%RH	120Vac, 60Hz	Chris Lin
APCM	25deg. C, 60%RH	120Vac, 60Hz	Frank Liu

3.3 DUTY CYCLE OF TEST SIGNAL

Duty cycle of test signal is 100 %, duty factor is not required.



3.4 DESCRIPTION OF SUPPORT UNITS

The EUT has been tested as an independent unit together with other necessary accessories or support units. The following support units or accessories were used to form a representative test configuration during the tests.

NO.	PRODUCT	BRAND	MODEL NO.	SERIAL NO.	FCC ID
1	NOTEBOOK	DELL	D531	CN-0XM006-48643-81U-2973	QDS-BRCM1020

NO.	SIGNAL CABLE DESCRIPTION OF THE ABOVE SUPPORT UNITS
1	NA

NOTE: All power cords of the above support units are non-shielded (1.8m).

3.4.1 CONFIGURATION OF SYSTEM UNDER TEST

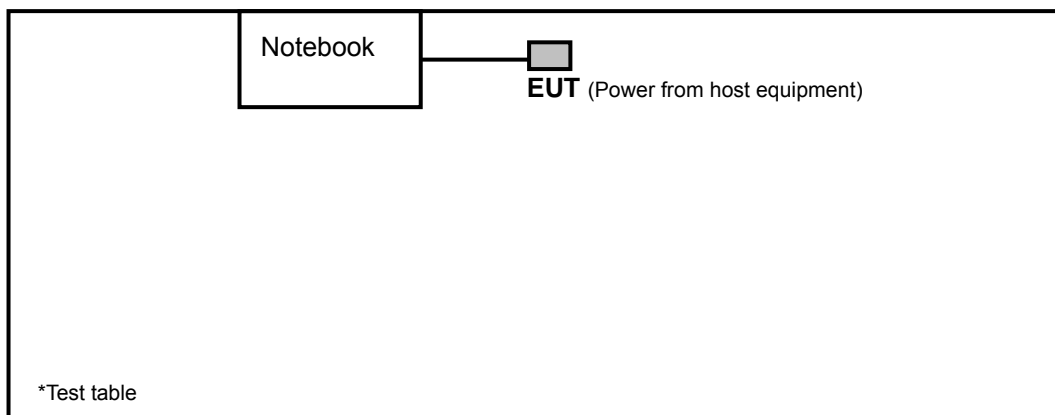

3.5 GENERAL DESCRIPTION OF APPLIED STANDARDS

The EUT is a RF Product. According to the specifications of the manufacturer, it must comply with the requirements of the following standards:

FCC Part 15, Subpart E (15.407)

789033 D01 General UNII Test Procedures v01 r02

662911 D01 Multiple Transmitter Output v01 r02

ANSI C63.10-2009

All test items have been performed and recorded as per the above standards.

NOTE: The EUT is also considered as a kind of computer peripheral, because the connection to computer is necessary for typical use. It has been verified to comply with the requirements of FCC Part 15, Subpart B, Class B (DoC). The test report has been issued separately.

4. TEST TYPES AND RESULTS

4.1 RADIATED EMISSION AND BANDEDGE MEASUREMENT

4.1.1 LIMITS OF RADIATED EMISSION AND BANDEDGE MEASUREMENT

Radiated emissions which fall in the restricted bands must comply with the radiated emission limits specified as below table:

FREQUENCIES (MHz)	FIELD STRENGTH (microvolts/meter)	MEASUREMENT DISTANCE (meters)
0.009 ~ 0.490	2400/F(kHz)	300
0.490 ~ 1.705	24000/F(kHz)	30
1.705 ~ 30.0	30	30
30 ~ 88	100	3
88 ~ 216	150	3
216 ~ 960	200	3
Above 960	500	3

NOTE:

1. The lower limit shall apply at the transition frequencies.
2. Emission level (dBuV/m) = 20 log Emission level (uV/m).
3. For frequencies above 1000MHz, the field strength limits are based on average detector, however, the peak field strength of any emission shall not exceed the maximum permitted average limits, specified above by more than 20dB under any condition of modulation.

4.1.2 LIMITS OF UNWANTED EMISSION OUT OF THE RESTRICTED BANDS

APPLICABLE TO	LIMIT	
√	FIELD STRENGTH AT 3m (dBμV/m)	
	PK	AV
	74	54
	EIRP LIMIT (dBm)	EQUIVALENT FIELD STRENGTH AT 3m (dBμV/m)
	PK	PK
	-27	68.3

NOTE: The following formula is used to convert the equipment isotropic radiated power (eirp) to field strength:

$$E = \frac{1000000\sqrt{30P}}{3} \mu\text{V/m, where P is the eirp (Watts).}$$

4.1.3 TEST INSTRUMENTS

DESCRIPTION & MANUFACTURER	MODEL NO.	SERIAL NO.	DATE OF CALIBRATION	DUE DATE OF CALIBRATION
Test Receiver ROHDE & SCHWARZ	ESIB7	100212	Aug. 06, 2012	Aug. 05, 2013
Spectrum Analyzer ROHDE & SCHWARZ	FSP40	100040	Jul. 16, 2012	Jul. 15, 2013
BILOG Antenna SCHWARZBECK	VULB9168	9168-160	Apr. 06, 2012	Apr. 05, 2013
HORN Antenna SCHWARZBECK	9120D	209	Sep. 03, 2012	Sep. 02, 2013
HORN Antenna SCHWARZBECK	BBHA 9170	148	Jul. 11, 2012	Jul. 10, 2013
Preamplifier Agilent	8447D	2944A10633	Oct. 25, 2012	Oct. 24, 2013
Preamplifier Agilent	8449B	3008A01964	Oct. 25, 2012	Oct. 24, 2013
RF signal cable HUBER+SUHNNER	SUCOFLEX 104	250723/4	Aug. 28, 2012	Aug. 27, 2013
RF signal cable HUBER+SUHNNER	SUCOFLEX 106	12738/6+309224/4	Aug. 28, 2012	Aug. 27, 2013
Software ADT.	ADT_Radiated_ V7.6.15.9.2	NA	NA	NA
Antenna Tower inn-co GmbH	MA 4000	013303	NA	NA
Antenna Tower Controller inn-co GmbH	CO2000	017303	NA	NA
Turn Table ADT.	TT100	TT93021703	NA	NA
Turn Table Controller ADT.	SC100	SC93021703	NA	NA
26GHz ~ 40GHz Amplifier	EM26400	815221	Oct. 25, 2012	Oct. 24, 2013
High Speed Peak Power Meter	ML2495A	0842014	Apr. 28, 2012	Apr. 27, 2013
Power Sensor	MA2411B	0738404	Apr. 28, 2012	Apr. 27, 2013
WIT Standard Temperature And Humidity Chamber	TH-4S-C	W981030	Jun. 13, 2012	Jun. 12, 2013

- NOTE:**
1. The calibration interval of the above test instruments is 12 months and the calibrations are traceable to NML/ROC and NIST/USA.
 2. The calibration interval of the loop antenna is 24 months and the calibrations are traceable to NML/ROC and NIST/USA.
 3. The test was performed in HwaYa Chamber 3.
 4. The horn antenna and HP preamplifier (model: 8449B) are used only for the measurement of emission frequency above 1GHz if tested.
 5. The FCC Site Registration No. is 988962.
 6. The IC Site Registration No. is IC 7450F-3.

4.1.4 TEST PROCEDURES

- a. The EUT was placed on the top of a rotating table 0.8 meters above the ground at a 3 meters semi-anechoic chamber. The table was rotated 360 degrees to determine the position of the highest radiation.
- b. The EUT was set 3 meters away from the interference-receiving antenna, which was mounted on the top of a variable-height antenna tower.
- c. The antenna is a broadband antenna, and its height is varied from one meter to four meters above the ground to determine the maximum value of the field strength. Both horizontal and vertical polarizations of the antenna are set to make the measurement.
- d. For each suspected emission, the EUT was arranged to its worst case and then the antenna was tuned to heights from 1 meter to 4 meters and the rotatable table was turned from 0 degrees to 360 degrees to find the maximum reading.
- e. The test-receiver system was set to Peak Detect Function and Specified Bandwidth with Maximum Hold Mode.
- f. If the emission level of the EUT in peak mode was lower than the limit specified, then testing could be stopped and the peak values of the EUT would be reported. Otherwise the emissions would be re-tested one by one using peak, quasi-peak or average method as specified and then reported in a data sheet.

NOTE:

1. The resolution bandwidth and video bandwidth of test receiver/spectrum analyzer is 120kHz for Quasi-peak detection at frequency below 1GHz.
2. The resolution bandwidth of test receiver/spectrum analyzer is 100kHz and video bandwidth is 300kHz for Peak detection at frequency above 1GHz.
3. The resolution bandwidth of test receiver/spectrum analyzer is 1MHz and the video bandwidth is 1kHz for Average detection (AV) at frequency above 1GHz.
4. All modes of operation were investigated and the worst-case emissions are reported.

4.1.5 DEVIATION FROM TEST STANDARD

No deviation.

4.1.6 TEST SETUP

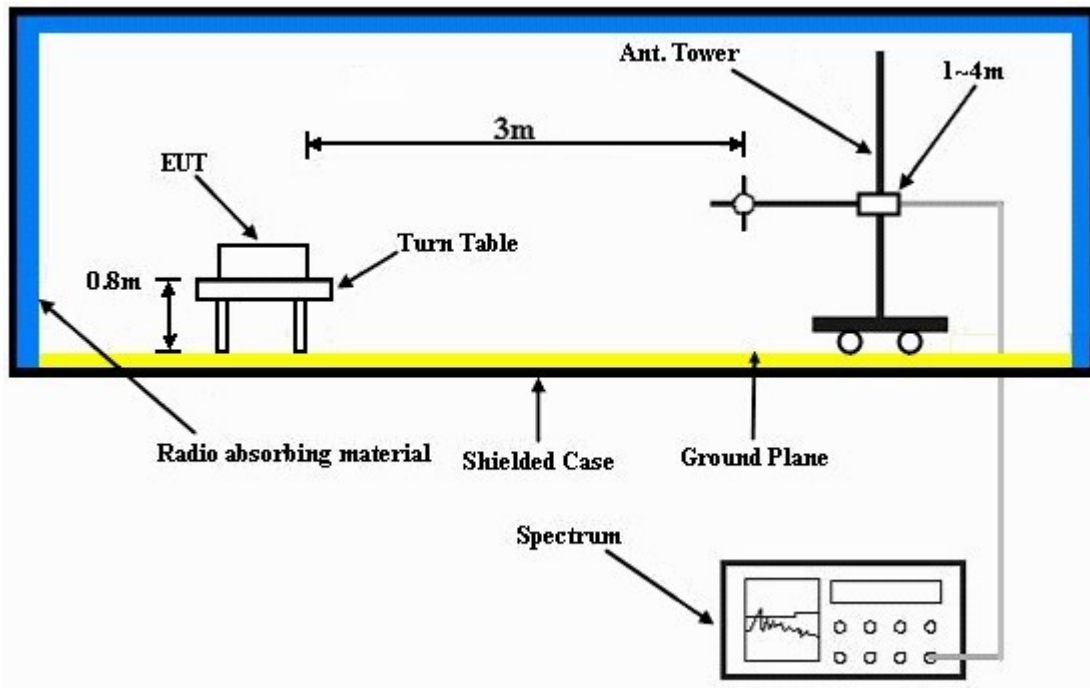

For the actual test configuration, please refer to the attached file (Test Setup Photo).

4.1.7 EUT OPERATING CONDITIONS

- a. The EUT was connected to the notebook with USB cable and placed them on the testing table.
- b. The notebook system ran a test program (provided by manufacturer) to enable EUT under transmission condition continuously at specific channel frequency.
- c. The necessary accessories enable the system in full functions.

4.1.8 TEST RESULTS

802.11a

EUT TEST CONDITION		MEASUREMENT DETAIL	
CHANNEL	Channel 36	FREQUENCY RANGE	1 ~ 40GHz
INPUT POWER (SYSTEM)	120Vac, 60Hz	DETECTOR FUNCTION	Peak (PK) Average (AV)
ENVIRONMENTAL CONDITIONS	25deg. C, 68%RH	TESTED BY	Sun Lin

ANTENNA POLARITY & TEST DISTANCE: HORIZONTAL AT 3 M								
NO.	FREQ. (MHz)	EMISSION LEVEL (dBuV/m)	LIMIT (dBuV/m)	MARGIN (dB)	ANTENNA HEIGHT (m)	TABLE ANGLE (Degree)	RAW VALUE (dBuV)	CORRECTION FACTOR (dB/m)
1	5150.00	49.0 PK	74.0	-25.0	1.24 H	307	11.20	37.80
2	5150.00	35.7 AV	54.0	-18.3	1.24 H	307	-2.10	37.80
3	*5180.00	98.1 PK			2.04 H	285	60.30	37.80
4	*5180.00	88.9 AV			2.04 H	285	51.10	37.80
5	#10360.00	57.0 PK	74.0	-17.0	1.35 H	351	8.20	48.80
6	#10360.00	44.3 AV	54.0	-9.7	1.35 H	351	-4.50	48.80
ANTENNA POLARITY & TEST DISTANCE: VERTICAL AT 3 M								
NO.	FREQ. (MHz)	EMISSION LEVEL (dBuV/m)	LIMIT (dBuV/m)	MARGIN (dB)	ANTENNA HEIGHT (m)	TABLE ANGLE (Degree)	RAW VALUE (dBuV)	CORRECTION FACTOR (dB/m)
1	5150.00	57.3 PK	74.0	-16.7	1.38 V	84	19.50	37.80
2	5150.00	44.1 AV	54.0	-9.9	1.38 V	84	6.30	37.80
3	*5180.00	101.6 PK			1.00 V	74	63.80	37.80
4	*5180.00	92.0 AV			1.00 V	74	54.20	37.80
5	#10360.00	60.6 PK	74.0	-13.4	1.83 V	272	11.80	48.80
6	#10360.00	47.4 AV	54.0	-6.6	1.83 V	272	-1.40	48.80

REMARKS:

1. Emission level (dBuV/m) = Raw Value (dBuV) + Correction Factor (dB/m).
2. Correction Factor (dB/m) = Antenna Factor (dB/m) + Cable Factor (dB).
3. The other emission levels were very low against the limit.
4. Margin value = Emission level – Limit value.
5. " * ": Fundamental frequency.
6. " # ": The radiated frequency is out of the restricted band.



A D T

EUT TEST CONDITION		MEASUREMENT DETAIL	
CHANNEL	Channel 40	FREQUENCY RANGE	1 ~ 40GHz
INPUT POWER (SYSTEM)	120Vac, 60Hz	DETECTOR FUNCTION	Peak (PK) Average (AV)
ENVIRONMENTAL CONDITIONS	25deg. C, 68%RH	TESTED BY	Sun Lin

ANTENNA POLARITY & TEST DISTANCE: HORIZONTAL AT 3 M								
NO.	FREQ. (MHz)	EMISSION LEVEL (dBuV/m)	LIMIT (dBuV/m)	MARGIN (dB)	ANTENNA HEIGHT (m)	TABLE ANGLE (Degree)	RAW VALUE (dBuV)	CORRECTION FACTOR (dB/m)
1	*5200.00	97.6 PK			1.95 H	258	59.70	37.90
2	*5200.00	88.5 AV			1.95 H	258	50.60	37.90
3	#10400.00	60.5 PK	74.0	-13.5	1.68 H	247	11.70	48.80
4	#10400.00	47.2 AV	54.0	-6.8	1.68 H	247	-1.60	48.80
ANTENNA POLARITY & TEST DISTANCE: VERTICAL AT 3 M								
NO.	FREQ. (MHz)	EMISSION LEVEL (dBuV/m)	LIMIT (dBuV/m)	MARGIN (dB)	ANTENNA HEIGHT (m)	TABLE ANGLE (Degree)	RAW VALUE (dBuV)	CORRECTION FACTOR (dB/m)
1	*5200.00	101.2 PK			1.00 V	89	63.30	37.90
2	*5200.00	91.5 AV			1.00 V	89	53.60	37.90
3	#10400.00	56.5 PK	74.0	-17.5	1.29 V	342	7.70	48.80
4	#10400.00	44.2 AV	54.0	-9.8	1.29 V	342	-4.60	48.80

REMARKS:

1. Emission level (dBuV/m) = Raw Value (dBuV) + Correction Factor (dB/m).
2. Correction Factor (dB/m) = Antenna Factor (dB/m) + Cable Factor (dB).
3. The other emission levels were very low against the limit.
4. Margin value = Emission level – Limit value.
5. " * ": Fundamental frequency.
6. " # ": The radiated frequency is out of the restricted band.



A D T

EUT TEST CONDITION		MEASUREMENT DETAIL	
CHANNEL	Channel 48	FREQUENCY RANGE	1 ~ 40GHz
INPUT POWER (SYSTEM)	120Vac, 60Hz	DETECTOR FUNCTION	Peak (PK) Average (AV)
ENVIRONMENTAL CONDITIONS	25deg. C, 68%RH	TESTED BY	Sun Lin

ANTENNA POLARITY & TEST DISTANCE: HORIZONTAL AT 3 M								
NO.	FREQ. (MHz)	EMISSION LEVEL (dBuV/m)	LIMIT (dBuV/m)	MARGIN (dB)	ANTENNA HEIGHT (m)	TABLE ANGLE (Degree)	RAW VALUE (dBuV)	CORRECTION FACTOR (dB/m)
1	*5240.00	98.8 PK			1.68 H	282	60.90	37.90
2	*5240.00	89.2 AV			1.68 H	282	51.30	37.90
3	#10480.00	56.2 PK	74.0	-17.8	1.34 H	347	7.20	49.00
4	#10480.00	43.5 AV	54.0	-10.5	1.34 H	347	-5.50	49.00
ANTENNA POLARITY & TEST DISTANCE: VERTICAL AT 3 M								
NO.	FREQ. (MHz)	EMISSION LEVEL (dBuV/m)	LIMIT (dBuV/m)	MARGIN (dB)	ANTENNA HEIGHT (m)	TABLE ANGLE (Degree)	RAW VALUE (dBuV)	CORRECTION FACTOR (dB/m)
1	*5240.00	102.0 PK			1.00 V	2	64.10	37.90
2	*5240.00	92.8 AV			1.00 V	2	54.90	37.90
3	#10480.00	57.4 PK	74.0	-16.6	1.23 V	268	8.40	49.00
4	#10480.00	47.0 AV	54.0	-7.0	1.23 V	268	-2.00	49.00

REMARKS:

1. Emission level (dBuV/m) = Raw Value (dBuV) + Correction Factor (dB/m).
2. Correction Factor (dB/m) = Antenna Factor (dB/m) + Cable Factor (dB).
3. The other emission levels were very low against the limit.
4. Margin value = Emission level – Limit value.
5. " * ": Fundamental frequency.
6. " # ": The radiated frequency is out of the restricted band.



A D T

EUT TEST CONDITION		MEASUREMENT DETAIL	
CHANNEL	Channel 52	FREQUENCY RANGE	1 ~ 40GHz
INPUT POWER (SYSTEM)	120Vac, 60Hz	DETECTOR FUNCTION	Peak (PK) Average (AV)
ENVIRONMENTAL CONDITIONS	25deg. C, 68%RH	TESTED BY	Sun Lin

ANTENNA POLARITY & TEST DISTANCE: HORIZONTAL AT 3 M								
NO.	FREQ. (MHz)	EMISSION LEVEL (dBuV/m)	LIMIT (dBuV/m)	MARGIN (dB)	ANTENNA HEIGHT (m)	TABLE ANGLE (Degree)	RAW VALUE (dBuV)	CORRECTION FACTOR (dB/m)
1	*5260.00	102.4 PK			2.05 H	265	64.50	37.90
2	*5260.00	92.5 AV			2.05 H	265	54.60	37.90
3	#10520.00	59.1 PK	74.0	-14.9	1.18 H	22	10.00	49.10
4	#10520.00	45.2 AV	54.0	-8.8	1.18 H	22	-3.90	49.10
5	15780.00	65.4 PK	74.0	-8.6	1.00 H	82	17.40	48.00
6	15780.00	51.5 AV	54.0	-2.5	1.00 H	82	3.50	48.00
ANTENNA POLARITY & TEST DISTANCE: VERTICAL AT 3 M								
NO.	FREQ. (MHz)	EMISSION LEVEL (dBuV/m)	LIMIT (dBuV/m)	MARGIN (dB)	ANTENNA HEIGHT (m)	TABLE ANGLE (Degree)	RAW VALUE (dBuV)	CORRECTION FACTOR (dB/m)
1	*5260.00	107.1 PK			1.08 V	76	69.20	37.90
2	*5260.00	96.1 AV			1.08 V	76	58.20	37.90
3	#10520.00	60.8 PK	74.0	-13.2	1.80 V	271	11.70	49.10
4	#10520.00	47.4 AV	54.0	-6.6	1.80 V	271	-1.70	49.10
5	15780.00	59.5 PK	74.0	-14.5	1.36 V	56	11.50	48.00
6	15780.00	46.5 AV	54.0	-7.5	1.36 V	56	-1.50	48.00

REMARKS:

1. Emission level (dBuV/m) = Raw Value (dBuV) + Correction Factor (dB/m).
2. Correction Factor (dB/m) = Antenna Factor (dB/m) + Cable Factor (dB).
3. The other emission levels were very low against the limit.
4. Margin value = Emission level – Limit value.
5. " * ": Fundamental frequency.
6. " # ": The radiated frequency is out of the restricted band.



A D T

EUT TEST CONDITION		MEASUREMENT DETAIL	
CHANNEL	Channel 60	FREQUENCY RANGE	1 ~ 40GHz
INPUT POWER (SYSTEM)	120Vac, 60Hz	DETECTOR FUNCTION	Peak (PK) Average (AV)
ENVIRONMENTAL CONDITIONS	25deg. C, 68%RH	TESTED BY	Sun Lin

ANTENNA POLARITY & TEST DISTANCE: HORIZONTAL AT 3 M								
NO.	FREQ. (MHz)	EMISSION LEVEL (dBuV/m)	LIMIT (dBuV/m)	MARGIN (dB)	ANTENNA HEIGHT (m)	TABLE ANGLE (Degree)	RAW VALUE (dBuV)	CORRECTION FACTOR (dB/m)
1	*5300.00	102.5 PK			2.01 H	288	64.50	38.00
2	*5300.00	92.5 AV			2.01 H	288	54.50	38.00
3	10600.00	59.3 PK	74.0	-14.7	1.48 H	317	10.30	49.00
4	10600.00	45.7 AV	54.0	-8.3	1.48 H	317	-3.30	49.00
5	15900.00	66.4 PK	74.0	-7.6	1.00 H	84	18.80	47.60
6	15900.00	53.0 AV	54.0	-1.0	1.00 H	84	5.40	47.60
ANTENNA POLARITY & TEST DISTANCE: VERTICAL AT 3 M								
NO.	FREQ. (MHz)	EMISSION LEVEL (dBuV/m)	LIMIT (dBuV/m)	MARGIN (dB)	ANTENNA HEIGHT (m)	TABLE ANGLE (Degree)	RAW VALUE (dBuV)	CORRECTION FACTOR (dB/m)
1	*5300.00	107.5 PK			1.12 V	98	69.50	38.00
2	*5300.00	96.4 AV			1.12 V	98	58.40	38.00
3	10600.00	61.2 PK	74.0	-12.8	1.67 V	258	12.20	49.00
4	10600.00	47.5 AV	54.0	-6.5	1.67 V	258	-1.50	49.00
5	15900.00	59.4 PK	74.0	-14.6	1.52 V	58	11.80	47.60
6	15900.00	46.2 AV	54.0	-7.8	1.52 V	58	-1.40	47.60

REMARKS:

1. Emission level (dBuV/m) = Raw Value (dBuV) + Correction Factor (dB/m).
2. Correction Factor (dB/m) = Antenna Factor (dB/m) + Cable Factor (dB).
3. The other emission levels were very low against the limit.
4. Margin value = Emission level – Limit value.
5. " * ": Fundamental frequency.



A D T

EUT TEST CONDITION		MEASUREMENT DETAIL	
CHANNEL	Channel 64	FREQUENCY RANGE	1 ~ 40GHz
INPUT POWER (SYSTEM)	120Vac, 60Hz	DETECTOR FUNCTION	Peak (PK) Average (AV)
ENVIRONMENTAL CONDITIONS	25deg. C, 68%RH	TESTED BY	Sun Lin

ANTENNA POLARITY & TEST DISTANCE: HORIZONTAL AT 3 M								
NO.	FREQ. (MHz)	EMISSION LEVEL (dBuV/m)	LIMIT (dBuV/m)	MARGIN (dB)	ANTENNA HEIGHT (m)	TABLE ANGLE (Degree)	RAW VALUE (dBuV)	CORRECTION FACTOR (dB/m)
1	*5320.00	102.3 PK			1.89 H	247	64.30	38.00
2	*5320.00	92.9 AV			1.89 H	247	54.90	38.00
3	5350.00	62.4 PK	74.0	-11.6	2.00 H	285	24.30	38.10
4	5350.00	48.9 AV	54.0	-5.1	2.00 H	285	10.80	38.10
5	10640.00	57.7 PK	74.0	-16.3	1.43 H	316	8.50	49.20
6	10640.00	44.9 AV	54.0	-9.1	1.43 H	316	-4.30	49.20
7	15960.00	66.6 PK	74.0	-7.4	1.00 H	85	19.10	47.50
8	15960.00	52.8 AV	54.0	-1.2	1.00 H	85	5.30	47.50
ANTENNA POLARITY & TEST DISTANCE: VERTICAL AT 3 M								
NO.	FREQ. (MHz)	EMISSION LEVEL (dBuV/m)	LIMIT (dBuV/m)	MARGIN (dB)	ANTENNA HEIGHT (m)	TABLE ANGLE (Degree)	RAW VALUE (dBuV)	CORRECTION FACTOR (dB/m)
1	*5320.00	108.2 PK			1.00 V	23	70.20	38.00
2	*5320.00	99.0 AV			1.00 V	23	61.00	38.00
3	5350.00	65.4 PK	74.0	-8.6	1.12 V	66	27.30	38.10
4	5350.00	52.2 AV	54.0	-1.8	1.12 V	66	14.10	38.10
5	10640.00	61.5 PK	74.0	-12.5	1.64 V	252	12.30	49.20
6	10640.00	47.8 AV	54.0	-6.2	1.64 V	252	-1.40	49.20
7	15900.00	58.9 PK	74.0	-15.1	1.22 V	47	11.30	47.60
8	15900.00	45.8 AV	54.0	-8.2	1.22 V	47	-1.80	47.60

REMARKS:

1. Emission level (dBuV/m) = Raw Value (dBuV) + Correction Factor (dB/m).
2. Correction Factor (dB/m) = Antenna Factor (dB/m) + Cable Factor (dB).
3. The other emission levels were very low against the limit.
4. Margin value = Emission level – Limit value.
5. " * ": Fundamental frequency.



A D T

EUT TEST CONDITION		MEASUREMENT DETAIL	
CHANNEL	Channel 100	FREQUENCY RANGE	1 ~ 40GHz
INPUT POWER (SYSTEM)	120Vac, 60Hz	DETECTOR FUNCTION	Peak (PK) Average (AV)
ENVIRONMENTAL CONDITIONS	25deg. C, 68%RH	TESTED BY	Sun Lin

ANTENNA POLARITY & TEST DISTANCE: HORIZONTAL AT 3 M								
NO.	FREQ. (MHz)	EMISSION LEVEL (dBuV/m)	LIMIT (dBuV/m)	MARGIN (dB)	ANTENNA HEIGHT (m)	TABLE ANGLE (Degree)	RAW VALUE (dBuV)	CORRECTION FACTOR (dB/m)
1	5460.00	58.5 PK	74.0	-15.5	1.85 H	285	20.20	38.30
2	5460.00	42.6 AV	54.0	-11.4	1.85 H	285	4.30	38.30
3	#5470.00	60.4 PK	74.0	-13.6	1.85 H	285	22.10	38.30
4	#5470.00	45.8 AV	54.0	-8.2	1.85 H	285	7.50	38.30
5	*5500.00	102.2 PK			1.69 H	275	63.90	38.30
6	*5500.00	92.0 AV			1.69 H	275	53.70	38.30
7	11000.00	57.6 PK	74.0	-16.4	1.58 H	22	7.90	49.70
8	11000.00	45.2 AV	54.0	-8.8	1.58 H	22	-4.50	49.70
9	#16500.00	64.1 PK	74.0	-9.9	1.06 H	82	15.20	48.90
10	#16500.00	51.2 AV	54.0	-2.8	1.06 H	82	2.30	48.90

ANTENNA POLARITY & TEST DISTANCE: VERTICAL AT 3 M								
NO.	FREQ. (MHz)	EMISSION LEVEL (dBuV/m)	LIMIT (dBuV/m)	MARGIN (dB)	ANTENNA HEIGHT (m)	TABLE ANGLE (Degree)	RAW VALUE (dBuV)	CORRECTION FACTOR (dB/m)
1	5460.00	63.2 PK	74.0	-10.8	1.09 V	40	24.90	38.30
2	5460.00	47.9 AV	54.0	-6.1	1.09 V	40	9.60	38.30
3	#5470.00	64.1 PK	74.0	-9.9	1.09 V	40	25.80	38.30
4	#5470.00	49.5 AV	54.0	-4.5	1.09 V	40	11.20	38.30
5	*5500.00	108.5 PK			1.08 V	30	70.20	38.30
6	*5500.00	98.8 AV			1.08 V	30	60.50	38.30
7	11000.00	61.5 PK	74.0	-12.5	1.65 V	252	11.80	49.70
8	11000.00	47.8 AV	54.0	-6.2	1.65 V	252	-1.90	49.70
9	#16500.00	58.6 PK	74.0	-15.4	1.42 V	57	9.70	48.90
10	#16500.00	45.8 AV	54.0	-8.2	1.42 V	57	-3.10	48.90

REMARKS:

1. Emission level (dBuV/m) = Raw Value (dBuV) + Correction Factor (dB/m).
2. Correction Factor (dB/m) = Antenna Factor (dB/m) + Cable Factor (dB).
3. The other emission levels were very low against the limit.
4. Margin value = Emission level – Limit value.
5. " * ": Fundamental frequency.
6. " # ": The radiated frequency is out of the restricted band.



EUT TEST CONDITION		MEASUREMENT DETAIL	
CHANNEL	Channel 116	FREQUENCY RANGE	1 ~ 40GHz
INPUT POWER (SYSTEM)	120Vac, 60Hz	DETECTOR FUNCTION	Peak (PK) Average (AV)
ENVIRONMENTAL CONDITIONS	25deg. C, 68%RH	TESTED BY	Sun Lin

ANTENNA POLARITY & TEST DISTANCE: HORIZONTAL AT 3 M								
NO.	FREQ. (MHz)	EMISSION LEVEL (dBuV/m)	LIMIT (dBuV/m)	MARGIN (dB)	ANTENNA HEIGHT (m)	TABLE ANGLE (Degree)	RAW VALUE (dBuV)	CORRECTION FACTOR (dB/m)
1	*5580.00	102.8 PK			1.96 H	247	64.40	38.40
2	*5580.00	92.6 AV			1.96 H	247	54.20	38.40
3	11160.00	54.0 PK	74.0	-20.0	1.35 H	15	4.50	49.50
4	11160.00	43.9 AV	54.0	-10.1	1.35 H	15	-5.60	49.50
5	#16740.00	60.9 PK	74.0	-13.1	1.00 H	102	11.10	49.80
6	#16740.00	47.8 AV	54.0	-6.2	1.00 H	102	-2.00	49.80
ANTENNA POLARITY & TEST DISTANCE: VERTICAL AT 3 M								
NO.	FREQ. (MHz)	EMISSION LEVEL (dBuV/m)	LIMIT (dBuV/m)	MARGIN (dB)	ANTENNA HEIGHT (m)	TABLE ANGLE (Degree)	RAW VALUE (dBuV)	CORRECTION FACTOR (dB/m)
1	*5580.00	109.0 PK			1.05 V	8	70.60	38.40
2	*5580.00	99.6 AV			1.05 V	8	61.20	38.40
3	11160.00	60.8 PK	74.0	-13.2	1.52 V	247	11.30	49.50
4	11160.00	47.2 AV	54.0	-6.8	1.52 V	247	-2.30	49.50
5	#16740.00	58.2 PK	74.0	-15.8	1.38 V	58	8.40	49.80
6	#16740.00	45.6 AV	54.0	-8.4	1.38 V	58	-4.20	49.80

REMARKS:

1. Emission level (dBuV/m) = Raw Value (dBuV) + Correction Factor (dB/m).
2. Correction Factor (dB/m) = Antenna Factor (dB/m) + Cable Factor (dB).
3. The other emission levels were very low against the limit.
4. Margin value = Emission level – Limit value.
5. " * ": Fundamental frequency.
6. " # ": The radiated frequency is out of the restricted band.



A D T

EUT TEST CONDITION		MEASUREMENT DETAIL	
CHANNEL	Channel 140	FREQUENCY RANGE	1 ~ 40GHz
INPUT POWER (SYSTEM)	120Vac, 60Hz	DETECTOR FUNCTION	Peak (PK) Average (AV)
ENVIRONMENTAL CONDITIONS	25deg. C, 68%RH	TESTED BY	Sun Lin

ANTENNA POLARITY & TEST DISTANCE: HORIZONTAL AT 3 M								
NO.	FREQ. (MHz)	EMISSION LEVEL (dBuV/m)	LIMIT (dBuV/m)	MARGIN (dB)	ANTENNA HEIGHT (m)	TABLE ANGLE (Degree)	RAW VALUE (dBuV)	CORRECTION FACTOR (dB/m)
1	*5700.00	102.8 PK			1.52 H	257	64.10	38.70
2	*5700.00	92.6 AV			1.52 H	257	53.90	38.70
3	#5725.00	65.6 PK	74.0	-8.4	1.48 H	265	26.90	38.70
4	#5725.00	46.2 AV	54.0	-7.8	1.48 H	265	7.50	38.70
5	11400.00	56.4 PK	74.0	-17.6	1.52 H	41	7.00	49.40
6	11400.00	45.7 AV	54.0	-8.3	1.52 H	41	-3.70	49.40
7	#17100.00	64.6 PK	74.0	-9.4	1.00 H	65	13.20	51.40
8	#17100.00	52.6 AV	54.0	-1.4	1.00 H	65	1.20	51.40
ANTENNA POLARITY & TEST DISTANCE: VERTICAL AT 3 M								
NO.	FREQ. (MHz)	EMISSION LEVEL (dBuV/m)	LIMIT (dBuV/m)	MARGIN (dB)	ANTENNA HEIGHT (m)	TABLE ANGLE (Degree)	RAW VALUE (dBuV)	CORRECTION FACTOR (dB/m)
1	*5700.00	109.2 PK			1.02 V	25	70.50	38.70
2	*5700.00	98.8 AV			1.02 V	25	60.10	38.70
3	#5725.00	70.2 PK	74.0	-3.8	1.01 V	62	31.50	38.70
4	#5725.00	52.3 AV	54.0	-1.7	1.01 V	62	13.60	38.70
5	11400.00	60.8 PK	74.0	-13.2	1.54 V	262	11.40	49.40
6	11400.00	47.5 AV	54.0	-6.5	1.54 V	262	-1.90	49.40
7	#17100.00	57.5 PK	74.0	-16.5	1.52 V	62	6.10	51.40
8	#17100.00	45.5 AV	54.0	-8.5	1.52 V	62	-5.90	51.40

REMARKS:

1. Emission level (dBuV/m) = Raw Value (dBuV) + Correction Factor (dB/m).
2. Correction Factor (dB/m) = Antenna Factor (dB/m) + Cable Factor (dB).
3. The other emission levels were very low against the limit.
4. Margin value = Emission level – Limit value.
5. " * ": Fundamental frequency.
6. " # ": The radiated frequency is out of the restricted band.



A D T

802.11n (20MHz)

EUT TEST CONDITION		MEASUREMENT DETAIL	
CHANNEL	Channel 36	FREQUENCY RANGE	1 ~ 40GHz
INPUT POWER (SYSTEM)	120Vac, 60Hz	DETECTOR FUNCTION	Peak (PK) Average (AV)
ENVIRONMENTAL CONDITIONS	25deg. C, 68%RH	TESTED BY	Sun Lin

ANTENNA POLARITY & TEST DISTANCE: HORIZONTAL AT 3 M								
NO.	FREQ. (MHz)	EMISSION LEVEL (dBuV/m)	LIMIT (dBuV/m)	MARGIN (dB)	ANTENNA HEIGHT (m)	TABLE ANGLE (Degree)	RAW VALUE (dBuV)	CORRECTION FACTOR (dB/m)
1	5150.00	53.5 PK	74.0	-20.5	1.00 H	171	15.70	37.80
2	5150.00	40.8 AV	54.0	-13.2	1.00 H	171	3.00	37.80
3	*5180.00	97.1 PK			1.20 H	105	59.30	37.80
4	*5180.00	86.1 AV			1.20 H	105	48.30	37.80
5	#10360.00	56.4 PK	74.0	-17.6	1.48 H	336	7.60	48.80
6	#10360.00	43.6 AV	54.0	-10.4	1.48 H	336	-5.20	48.80
ANTENNA POLARITY & TEST DISTANCE: VERTICAL AT 3 M								
NO.	FREQ. (MHz)	EMISSION LEVEL (dBuV/m)	LIMIT (dBuV/m)	MARGIN (dB)	ANTENNA HEIGHT (m)	TABLE ANGLE (Degree)	RAW VALUE (dBuV)	CORRECTION FACTOR (dB/m)
1	5150.00	48.0 PK	74.0	-26.0	1.29 V	183	10.20	37.80
2	5150.00	38.8 AV	54.0	-15.2	1.29 V	183	1.00	37.80
3	*5180.00	101.2 PK			1.26 V	184	63.40	37.80
4	*5180.00	90.9 AV			1.26 V	184	53.10	37.80
5	#10360.00	52.8 PK	74.0	-21.2	1.16 V	26	4.00	48.80
6	#10360.00	42.1 AV	54.0	-11.9	1.16 V	26	-6.70	48.80

REMARKS:

1. Emission level (dBuV/m) = Raw Value (dBuV) + Correction Factor (dB/m).
2. Correction Factor (dB/m) = Antenna Factor (dB/m) + Cable Factor (dB).
3. The other emission levels were very low against the limit.
4. Margin value = Emission level – Limit value.
5. " * ": Fundamental frequency.
6. " # ": The radiated frequency is out of the restricted band.



A D T

EUT TEST CONDITION		MEASUREMENT DETAIL	
CHANNEL	Channel 40	FREQUENCY RANGE	1 ~ 40GHz
INPUT POWER (SYSTEM)	120Vac, 60Hz	DETECTOR FUNCTION	Peak (PK) Average (AV)
ENVIRONMENTAL CONDITIONS	25deg. C, 68%RH	TESTED BY	Sun Lin

ANTENNA POLARITY & TEST DISTANCE: HORIZONTAL AT 3 M								
NO.	FREQ. (MHz)	EMISSION LEVEL (dBuV/m)	LIMIT (dBuV/m)	MARGIN (dB)	ANTENNA HEIGHT (m)	TABLE ANGLE (Degree)	RAW VALUE (dBuV)	CORRECTION FACTOR (dB/m)
1	*5200.00	97.6 PK			1.15 H	98	59.70	37.90
2	*5200.00	86.4 AV			1.15 H	98	48.50	37.90
3	#10400.00	55.4 PK	74.0	-18.6	1.32 H	296	6.60	48.80
4	#10400.00	42.7 AV	54.0	-11.3	1.32 H	296	-6.10	48.80

ANTENNA POLARITY & TEST DISTANCE: VERTICAL AT 3 M								
NO.	FREQ. (MHz)	EMISSION LEVEL (dBuV/m)	LIMIT (dBuV/m)	MARGIN (dB)	ANTENNA HEIGHT (m)	TABLE ANGLE (Degree)	RAW VALUE (dBuV)	CORRECTION FACTOR (dB/m)
1	*5200.00	101.4 PK			1.02 V	185	63.50	37.90
2	*5200.00	91.3 AV			1.02 V	185	53.40	37.90
3	#10400.00	53.8 PK	74.0	-20.2	1.21 V	32	5.00	48.80
4	#10400.00	43.2 AV	54.0	-10.8	1.21 V	32	-5.60	48.80

REMARKS:

1. Emission level (dBuV/m) = Raw Value (dBuV) + Correction Factor (dB/m).
2. Correction Factor (dB/m) = Antenna Factor (dB/m) + Cable Factor (dB).
3. The other emission levels were very low against the limit.
4. Margin value = Emission level – Limit value.
5. " * " : Fundamental frequency.
6. " # " : The radiated frequency is out of the restricted band.



A D T

EUT TEST CONDITION		MEASUREMENT DETAIL	
CHANNEL	Channel 48	FREQUENCY RANGE	1 ~ 40GHz
INPUT POWER (SYSTEM)	120Vac, 60Hz	DETECTOR FUNCTION	Peak (PK) Average (AV)
ENVIRONMENTAL CONDITIONS	25deg. C, 68%RH	TESTED BY	Sun Lin

ANTENNA POLARITY & TEST DISTANCE: HORIZONTAL AT 3 M								
NO.	FREQ. (MHz)	EMISSION LEVEL (dBuV/m)	LIMIT (dBuV/m)	MARGIN (dB)	ANTENNA HEIGHT (m)	TABLE ANGLE (Degree)	RAW VALUE (dBuV)	CORRECTION FACTOR (dB/m)
1	*5240.00	97.2 PK			1.02 H	168	59.30	37.90
2	*5240.00	85.8 AV			1.02 H	168	47.90	37.90
3	#10480.00	53.9 PK	74.0	-20.1	1.38 H	305	4.90	49.00
4	#10480.00	43.2 AV	54.0	-10.8	1.38 H	305	-5.80	49.00
ANTENNA POLARITY & TEST DISTANCE: VERTICAL AT 3 M								
NO.	FREQ. (MHz)	EMISSION LEVEL (dBuV/m)	LIMIT (dBuV/m)	MARGIN (dB)	ANTENNA HEIGHT (m)	TABLE ANGLE (Degree)	RAW VALUE (dBuV)	CORRECTION FACTOR (dB/m)
1	*5240.00	100.8 PK			1.11 V	138	62.90	37.90
2	*5240.00	91.2 AV			1.11 V	138	53.30	37.90
3	#10480.00	55.8 PK	74.0	-18.2	1.32 V	299	6.80	49.00
4	#10480.00	43.8 AV	54.0	-10.2	1.32 V	299	-5.20	49.00

REMARKS:

1. Emission level (dBuV/m) = Raw Value (dBuV) + Correction Factor (dB/m).
2. Correction Factor (dB/m) = Antenna Factor (dB/m) + Cable Factor (dB).
3. The other emission levels were very low against the limit.
4. Margin value = Emission level – Limit value.
5. " * ": Fundamental frequency.
6. " # ": The radiated frequency is out of the restricted band.



A D T

EUT TEST CONDITION		MEASUREMENT DETAIL	
CHANNEL	Channel 52	FREQUENCY RANGE	1 ~ 40GHz
INPUT POWER (SYSTEM)	120Vac, 60Hz	DETECTOR FUNCTION	Peak (PK) Average (AV)
ENVIRONMENTAL CONDITIONS	25deg. C, 68%RH	TESTED BY	Sun Lin

ANTENNA POLARITY & TEST DISTANCE: HORIZONTAL AT 3 M								
NO.	FREQ. (MHz)	EMISSION LEVEL (dBuV/m)	LIMIT (dBuV/m)	MARGIN (dB)	ANTENNA HEIGHT (m)	TABLE ANGLE (Degree)	RAW VALUE (dBuV)	CORRECTION FACTOR (dB/m)
1	*5260.00	104.4 PK			1.02 H	167	66.50	37.90
2	*5260.00	94.1 AV			1.02 H	167	56.20	37.90
3	#10520.00	58.3 PK	74.0	-15.7	1.48 H	325	9.20	49.10
4	#10520.00	44.9 AV	54.0	-9.1	1.48 H	325	-4.20	49.10
5	15780.00	64.9 PK	74.0	-9.1	1.00 H	72	16.90	48.00
6	15780.00	51.5 AV	54.0	-2.5	1.00 H	72	3.50	48.00

ANTENNA POLARITY & TEST DISTANCE: VERTICAL AT 3 M								
NO.	FREQ. (MHz)	EMISSION LEVEL (dBuV/m)	LIMIT (dBuV/m)	MARGIN (dB)	ANTENNA HEIGHT (m)	TABLE ANGLE (Degree)	RAW VALUE (dBuV)	CORRECTION FACTOR (dB/m)
1	*5260.00	109.4 PK			1.32 V	174	71.50	37.90
2	*5260.00	98.2 AV			1.32 V	174	60.30	37.90
3	#10520.00	56.2 PK	74.0	-17.8	1.05 V	267	7.10	49.10
4	#10520.00	44.0 AV	54.0	-10.0	1.05 V	267	-5.10	49.10
5	15780.00	54.9 PK	74.0	-19.1	1.49 V	282	6.90	48.00
6	15780.00	43.7 AV	54.0	-10.3	1.49 V	282	-4.30	48.00

REMARKS:

1. Emission level (dBuV/m) = Raw Value (dBuV) + Correction Factor (dB/m).
2. Correction Factor (dB/m) = Antenna Factor (dB/m) + Cable Factor (dB).
3. The other emission levels were very low against the limit.
4. Margin value = Emission level – Limit value.
5. " * " : Fundamental frequency.
6. " # " : The radiated frequency is out of the restricted band.



A D T

EUT TEST CONDITION		MEASUREMENT DETAIL	
CHANNEL	Channel 60	FREQUENCY RANGE	1 ~ 40GHz
INPUT POWER (SYSTEM)	120Vac, 60Hz	DETECTOR FUNCTION	Peak (PK) Average (AV)
ENVIRONMENTAL CONDITIONS	25deg. C, 68%RH	TESTED BY	Sun Lin

ANTENNA POLARITY & TEST DISTANCE: HORIZONTAL AT 3 M								
NO.	FREQ. (MHz)	EMISSION LEVEL (dBuV/m)	LIMIT (dBuV/m)	MARGIN (dB)	ANTENNA HEIGHT (m)	TABLE ANGLE (Degree)	RAW VALUE (dBuV)	CORRECTION FACTOR (dB/m)
1	*5300.00	104.8 PK			1.05 H	158	66.80	38.00
2	*5300.00	93.5 AV			1.05 H	158	55.50	38.00
3	10600.00	57.9 PK	74.0	-16.1	1.52 H	341	8.90	49.00
4	10600.00	44.5 AV	54.0	-9.5	1.52 H	341	-4.50	49.00
5	15900.00	64.7 PK	74.0	-9.3	1.00 H	107	17.10	47.60
6	15900.00	51.2 AV	54.0	-2.8	1.00 H	107	3.60	47.60
ANTENNA POLARITY & TEST DISTANCE: VERTICAL AT 3 M								
NO.	FREQ. (MHz)	EMISSION LEVEL (dBuV/m)	LIMIT (dBuV/m)	MARGIN (dB)	ANTENNA HEIGHT (m)	TABLE ANGLE (Degree)	RAW VALUE (dBuV)	CORRECTION FACTOR (dB/m)
1	*5300.00	109.8 PK			1.35 V	152	71.80	38.00
2	*5300.00	98.8 AV			1.35 V	152	60.80	38.00
3	10600.00	55.8 PK	74.0	-18.2	1.08 V	252	6.80	49.00
4	10600.00	43.5 AV	54.0	-10.5	1.08 V	252	-5.50	49.00
5	15900.00	52.5 PK	74.0	-21.5	1.23 V	307	4.90	47.60
6	15900.00	41.3 AV	54.0	-12.7	1.23 V	307	-6.30	47.60

REMARKS:

1. Emission level (dBuV/m) = Raw Value (dBuV) + Correction Factor (dB/m).
2. Correction Factor (dB/m) = Antenna Factor (dB/m) + Cable Factor (dB).
3. The other emission levels were very low against the limit.
4. Margin value = Emission level – Limit value.
5. " * ": Fundamental frequency.



A D T

EUT TEST CONDITION		MEASUREMENT DETAIL	
CHANNEL	Channel 64	FREQUENCY RANGE	1 ~ 40GHz
INPUT POWER (SYSTEM)	120Vac, 60Hz	DETECTOR FUNCTION	Peak (PK) Average (AV)
ENVIRONMENTAL CONDITIONS	25deg. C, 68%RH	TESTED BY	Sun Lin

ANTENNA POLARITY & TEST DISTANCE: HORIZONTAL AT 3 M								
NO.	FREQ. (MHz)	EMISSION LEVEL (dBuV/m)	LIMIT (dBuV/m)	MARGIN (dB)	ANTENNA HEIGHT (m)	TABLE ANGLE (Degree)	RAW VALUE (dBuV)	CORRECTION FACTOR (dB/m)
1	*5320.00	105.6 PK			1.08 H	152	67.60	38.00
2	*5320.00	94.0 AV			1.08 H	152	56.00	38.00
3	5350.00	62.8 PK	74.0	-11.2	1.00 H	147	24.70	38.10
4	5350.00	46.8 AV	54.0	-7.2	1.00 H	147	8.70	38.10
5	10640.00	56.4 PK	74.0	-17.6	1.52 H	345	7.20	49.20
6	10640.00	44.6 AV	54.0	-9.4	1.52 H	345	-4.60	49.20
7	15960.00	65.1 PK	74.0	-8.9	1.01 H	106	17.60	47.50
8	15960.00	51.3 AV	54.0	-2.7	1.01 H	106	3.80	47.50
ANTENNA POLARITY & TEST DISTANCE: VERTICAL AT 3 M								
NO.	FREQ. (MHz)	EMISSION LEVEL (dBuV/m)	LIMIT (dBuV/m)	MARGIN (dB)	ANTENNA HEIGHT (m)	TABLE ANGLE (Degree)	RAW VALUE (dBuV)	CORRECTION FACTOR (dB/m)
1	*5320.00	110.8 PK			1.22 V	108	72.80	38.00
2	*5320.00	99.7 AV			1.22 V	108	61.70	38.00
3	5350.00	67.6 PK	74.0	-6.4	1.28 V	94	29.50	38.10
4	5350.00	52.7 AV	54.0	-1.3	1.28 V	94	14.60	38.10
5	10640.00	54.1 PK	74.0	-19.9	1.08 V	274	4.90	49.20
6	10640.00	43.5 AV	54.0	-10.5	1.08 V	274	-5.70	49.20
7	15960.00	55.2 PK	74.0	-18.8	1.52 V	304	7.70	47.50
8	15960.00	44.8 AV	54.0	-9.2	1.52 V	304	-2.70	47.50

REMARKS:

1. Emission level (dBuV/m) = Raw Value (dBuV) + Correction Factor (dB/m).
2. Correction Factor (dB/m) = Antenna Factor (dB/m) + Cable Factor (dB).
3. The other emission levels were very low against the limit.
4. Margin value = Emission level – Limit value.
5. " * ": Fundamental frequency.



EUT TEST CONDITION		MEASUREMENT DETAIL	
CHANNEL	Channel 100	FREQUENCY RANGE	1 ~ 40GHz
INPUT POWER (SYSTEM)	120Vac, 60Hz	DETECTOR FUNCTION	Peak (PK) Average (AV)
ENVIRONMENTAL CONDITIONS	25deg. C, 68%RH	TESTED BY	Sun Lin

ANTENNA POLARITY & TEST DISTANCE: HORIZONTAL AT 3 M								
NO.	FREQ. (MHz)	EMISSION LEVEL (dBuV/m)	LIMIT (dBuV/m)	MARGIN (dB)	ANTENNA HEIGHT (m)	TABLE ANGLE (Degree)	RAW VALUE (dBuV)	CORRECTION FACTOR (dB/m)
1	5460.00	61.4 PK	74.0	-12.6	1.02 H	152	23.10	38.30
2	5460.00	45.8 AV	54.0	-8.2	1.02 H	152	7.50	38.30
3	#5470.00	63.1 PK	74.0	-10.9	1.02 H	152	24.80	38.30
4	#5470.00	50.8 AV	54.0	-3.2	1.02 H	152	12.50	38.30
5	*5500.00	104.9 PK			1.08 H	145	66.60	38.30
6	*5500.00	94.5 AV			1.08 H	145	56.20	38.30
7	11000.00	64.2 PK	74.0	-9.8	1.05 H	68	14.50	49.70
8	11000.00	50.8 AV	54.0	-3.2	1.05 H	68	1.10	49.70
ANTENNA POLARITY & TEST DISTANCE: VERTICAL AT 3 M								
NO.	FREQ. (MHz)	EMISSION LEVEL (dBuV/m)	LIMIT (dBuV/m)	MARGIN (dB)	ANTENNA HEIGHT (m)	TABLE ANGLE (Degree)	RAW VALUE (dBuV)	CORRECTION FACTOR (dB/m)
1	5460.00	65.3 PK	74.0	-8.7	1.06 V	42	27.00	38.30
2	5460.00	50.6 AV	54.0	-3.4	1.06 V	42	12.30	38.30
3	#5470.00	65.9 PK	74.0	-8.1	1.06 V	42	27.60	38.30
4	#5470.00	51.9 AV	54.0	-2.1	1.06 V	42	13.60	38.30
5	*5500.00	111.3 PK			1.06 V	43	73.00	38.30
6	*5500.00	100.2 AV			1.06 V	43	61.90	38.30
7	11000.00	55.0 PK	74.0	-19.0	1.35 V	304	5.30	49.70
8	11000.00	45.2 AV	54.0	-8.8	1.35 V	304	-4.50	49.70

REMARKS:

1. Emission level (dBuV/m) = Raw Value (dBuV) + Correction Factor (dB/m).
2. Correction Factor (dB/m) = Antenna Factor (dB/m) + Cable Factor (dB).
3. The other emission levels were very low against the limit.
4. Margin value = Emission level – Limit value.
5. " * ": Fundamental frequency.
6. " # ": The radiated frequency is out of the restricted band.



A D T

EUT TEST CONDITION		MEASUREMENT DETAIL	
CHANNEL	Channel 116	FREQUENCY RANGE	1 ~ 40GHz
INPUT POWER (SYSTEM)	120Vac, 60Hz	DETECTOR FUNCTION	Peak (PK) Average (AV)
ENVIRONMENTAL CONDITIONS	25deg. C, 68%RH	TESTED BY	Sun Lin

ANTENNA POLARITY & TEST DISTANCE: HORIZONTAL AT 3 M								
NO.	FREQ. (MHz)	EMISSION LEVEL (dBuV/m)	LIMIT (dBuV/m)	MARGIN (dB)	ANTENNA HEIGHT (m)	TABLE ANGLE (Degree)	RAW VALUE (dBuV)	CORRECTION FACTOR (dB/m)
1	*5580.00	105.2 PK			1.05 H	172	66.80	38.40
2	*5580.00	94.8 AV			1.05 H	172	56.40	38.40
3	11160.00	57.5 PK	74.0	-16.5	1.32 H	305	8.00	49.50
4	11160.00	44.2 AV	54.0	-9.8	1.32 H	305	-5.30	49.50
ANTENNA POLARITY & TEST DISTANCE: VERTICAL AT 3 M								
NO.	FREQ. (MHz)	EMISSION LEVEL (dBuV/m)	LIMIT (dBuV/m)	MARGIN (dB)	ANTENNA HEIGHT (m)	TABLE ANGLE (Degree)	RAW VALUE (dBuV)	CORRECTION FACTOR (dB/m)
1	*5580.00	109.5 PK			1.28 V	158	71.10	38.40
2	*5580.00	99.0 AV			1.28 V	158	60.60	38.40
3	11160.00	55.8 PK	74.0	-18.2	1.04 V	217	6.30	49.50
4	11160.00	42.8 AV	54.0	-11.2	1.04 V	217	-6.70	49.50

REMARKS:

1. Emission level (dBuV/m) = Raw Value (dBuV) + Correction Factor (dB/m).
2. Correction Factor (dB/m) = Antenna Factor (dB/m) + Cable Factor (dB).
3. The other emission levels were very low against the limit.
4. Margin value = Emission level – Limit value.
5. " * ": Fundamental frequency.



A D T

EUT TEST CONDITION		MEASUREMENT DETAIL	
CHANNEL	Channel 140	FREQUENCY RANGE	1 ~ 40GHz
INPUT POWER (SYSTEM)	120Vac, 60Hz	DETECTOR FUNCTION	Peak (PK) Average (AV)
ENVIRONMENTAL CONDITIONS	25deg. C, 68%RH	TESTED BY	Sun Lin

ANTENNA POLARITY & TEST DISTANCE: HORIZONTAL AT 3 M								
NO.	FREQ. (MHz)	EMISSION LEVEL (dBuV/m)	LIMIT (dBuV/m)	MARGIN (dB)	ANTENNA HEIGHT (m)	TABLE ANGLE (Degree)	RAW VALUE (dBuV)	CORRECTION FACTOR (dB/m)
1	*5700.00	97.5 PK			1.05 H	165	58.80	38.70
2	*5700.00	87.6 AV			1.05 H	165	48.90	38.70
3	#5725.00	62.2 PK	74.0	-11.8	1.04 H	178	23.50	38.70
4	#5725.00	47.5 AV	54.0	-6.5	1.04 H	178	8.80	38.70
5	11400.00	62.4 PK	74.0	-11.6	1.01 H	69	13.00	49.40
6	11400.00	48.2 AV	54.0	-5.8	1.01 H	69	-1.20	49.40
ANTENNA POLARITY & TEST DISTANCE: VERTICAL AT 3 M								
NO.	FREQ. (MHz)	EMISSION LEVEL (dBuV/m)	LIMIT (dBuV/m)	MARGIN (dB)	ANTENNA HEIGHT (m)	TABLE ANGLE (Degree)	RAW VALUE (dBuV)	CORRECTION FACTOR (dB/m)
1	*5700.00	104.5 PK			1.17 V	202	65.80	38.70
2	*5700.00	94.7 AV			1.17 V	202	56.00	38.70
3	#5725.00	66.0 PK	74.0	-8.0	1.03 V	195	27.30	38.70
4	#5725.00	52.4 AV	54.0	-1.6	1.03 V	195	13.70	38.70
5	11400.00	54.7 PK	74.0	-19.3	1.08 V	56	5.30	49.40
6	11400.00	45.8 AV	54.0	-8.2	1.08 V	56	-3.60	49.40

REMARKS:

1. Emission level (dBuV/m) = Raw Value (dBuV) + Correction Factor (dB/m).
2. Correction Factor (dB/m) = Antenna Factor (dB/m) + Cable Factor (dB).
3. The other emission levels were very low against the limit.
4. Margin value = Emission level – Limit value.
5. " * ": Fundamental frequency.
6. " # ": The radiated frequency is out of the restricted band.

802.11n (40MHz)

EUT TEST CONDITION		MEASUREMENT DETAIL	
CHANNEL	Channel 38	FREQUENCY RANGE	1 ~ 40GHz
INPUT POWER (SYSTEM)	120Vac, 60Hz	DETECTOR FUNCTION	Peak (PK) Average (AV)
ENVIRONMENTAL CONDITIONS	25deg. C, 68%RH	TESTED BY	Sun Lin

ANTENNA POLARITY & TEST DISTANCE: HORIZONTAL AT 3 M								
NO.	FREQ. (MHz)	EMISSION LEVEL (dBuV/m)	LIMIT (dBuV/m)	MARGIN (dB)	ANTENNA HEIGHT (m)	TABLE ANGLE (Degree)	RAW VALUE (dBuV)	CORRECTION FACTOR (dB/m)
1	5150.00	56.4 PK	74.0	-17.6	1.03 H	318	18.60	37.80
2	5150.00	44.2 AV	54.0	-9.8	1.03 H	318	6.40	37.80
3	*5190.00	97.4 PK			1.27 H	298	59.60	37.80
4	*5190.00	87.0 AV			1.27 H	298	49.20	37.80
5	#10380.00	54.2 PK	74.0	-19.8	1.39 H	322	5.40	48.80
6	#10380.00	42.8 AV	54.0	-11.2	1.39 H	322	-6.00	48.80
ANTENNA POLARITY & TEST DISTANCE: VERTICAL AT 3 M								
NO.	FREQ. (MHz)	EMISSION LEVEL (dBuV/m)	LIMIT (dBuV/m)	MARGIN (dB)	ANTENNA HEIGHT (m)	TABLE ANGLE (Degree)	RAW VALUE (dBuV)	CORRECTION FACTOR (dB/m)
1	5150.00	60.8 PK	74.0	-13.2	1.22 V	118	23.00	37.80
2	5150.00	48.0 AV	54.0	-6.0	1.22 V	118	10.20	37.80
3	*5190.00	102.1 PK			1.21 V	118	64.30	37.80
4	*5190.00	92.6 AV			1.21 V	118	54.80	37.80
5	#10380.00	55.5 PK	74.0	-18.5	1.05 V	95	6.70	48.80
6	#10380.00	44.0 AV	54.0	-10.0	1.05 V	95	-4.80	48.80

REMARKS:

1. Emission level (dBuV/m) = Raw Value (dBuV) + Correction Factor (dB/m).
2. Correction Factor (dB/m) = Antenna Factor (dB/m) + Cable Factor (dB).
3. The other emission levels were very low against the limit.
4. Margin value = Emission level – Limit value.
5. " * ": Fundamental frequency.
6. " # ": The radiated frequency is out of the restricted band.



A D T

EUT TEST CONDITION		MEASUREMENT DETAIL	
CHANNEL	Channel 46	FREQUENCY RANGE	1 ~ 40GHz
INPUT POWER (SYSTEM)	120Vac, 60Hz	DETECTOR FUNCTION	Peak (PK) Average (AV)
ENVIRONMENTAL CONDITIONS	25deg. C, 68%RH	TESTED BY	Sun Lin

ANTENNA POLARITY & TEST DISTANCE: HORIZONTAL AT 3 M								
NO.	FREQ. (MHz)	EMISSION LEVEL (dBuV/m)	LIMIT (dBuV/m)	MARGIN (dB)	ANTENNA HEIGHT (m)	TABLE ANGLE (Degree)	RAW VALUE (dBuV)	CORRECTION FACTOR (dB/m)
1	*5230.00	97.5 PK			1.24 H	321	59.60	37.90
2	*5230.00	86.8 AV			1.24 H	321	48.90	37.90
3	#10460.00	52.9 PK	74.0	-21.1	1.36 H	258	3.90	49.00
4	#10460.00	43.4 AV	54.0	-10.6	1.36 H	258	-5.60	49.00
ANTENNA POLARITY & TEST DISTANCE: VERTICAL AT 3 M								
NO.	FREQ. (MHz)	EMISSION LEVEL (dBuV/m)	LIMIT (dBuV/m)	MARGIN (dB)	ANTENNA HEIGHT (m)	TABLE ANGLE (Degree)	RAW VALUE (dBuV)	CORRECTION FACTOR (dB/m)
1	*5230.00	101.8 PK			1.02 V	15	63.90	37.90
2	*5230.00	92.7 AV			1.02 V	15	54.80	37.90
3	#10460.00	54.1 PK	74.0	-19.9	1.04 V	102	5.10	49.00
4	#10460.00	44.4 AV	54.0	-9.6	1.04 V	102	-4.60	49.00

REMARKS:

1. Emission level (dBuV/m) = Raw Value (dBuV) + Correction Factor (dB/m).
2. Correction Factor (dB/m) = Antenna Factor (dB/m) + Cable Factor (dB).
3. The other emission levels were very low against the limit.
4. Margin value = Emission level – Limit value.
5. " * ": Fundamental frequency.
6. " # ": The radiated frequency is out of the restricted band.



A D T

EUT TEST CONDITION		MEASUREMENT DETAIL	
CHANNEL	Channel 54	FREQUENCY RANGE	1 ~ 40GHz
INPUT POWER (SYSTEM)	120Vac, 60Hz	DETECTOR FUNCTION	Peak (PK) Average (AV)
ENVIRONMENTAL CONDITIONS	25deg. C, 68%RH	TESTED BY	Sun Lin

ANTENNA POLARITY & TEST DISTANCE: HORIZONTAL AT 3 M								
NO.	FREQ. (MHz)	EMISSION LEVEL (dBuV/m)	LIMIT (dBuV/m)	MARGIN (dB)	ANTENNA HEIGHT (m)	TABLE ANGLE (Degree)	RAW VALUE (dBuV)	CORRECTION FACTOR (dB/m)
1	*5270.00	101.2 PK			1.05 H	269	63.20	38.00
2	*5270.00	91.8 AV			1.05 H	269	53.80	38.00
3	#10520.00	53.8 PK	74.0	-20.2	1.34 H	302	4.70	49.10
4	#10520.00	42.4 AV	54.0	-11.6	1.34 H	302	-6.70	49.10
ANTENNA POLARITY & TEST DISTANCE: VERTICAL AT 3 M								
NO.	FREQ. (MHz)	EMISSION LEVEL (dBuV/m)	LIMIT (dBuV/m)	MARGIN (dB)	ANTENNA HEIGHT (m)	TABLE ANGLE (Degree)	RAW VALUE (dBuV)	CORRECTION FACTOR (dB/m)
1	*5270.00	108.5 PK			1.12 V	105	70.50	38.00
2	*5270.00	99.5 AV			1.12 V	105	61.50	38.00
3	#10520.00	54.9 PK	74.0	-19.1	1.08 V	107	5.80	49.10
4	#10520.00	43.5 AV	54.0	-10.5	1.08 V	107	-5.60	49.10

REMARKS:

1. Emission level (dBuV/m) = Raw Value (dBuV) + Correction Factor (dB/m).
2. Correction Factor (dB/m) = Antenna Factor (dB/m) + Cable Factor (dB).
3. The other emission levels were very low against the limit.
4. Margin value = Emission level – Limit value.
5. " * ": Fundamental frequency.
6. " # ": The radiated frequency is out of the restricted band.



EUT TEST CONDITION		MEASUREMENT DETAIL	
CHANNEL	Channel 62	FREQUENCY RANGE	1 ~ 40GHz
INPUT POWER (SYSTEM)	120Vac, 60Hz	DETECTOR FUNCTION	Peak (PK) Average (AV)
ENVIRONMENTAL CONDITIONS	25deg. C, 68%RH	TESTED BY	Sun Lin

ANTENNA POLARITY & TEST DISTANCE: HORIZONTAL AT 3 M								
NO.	FREQ. (MHz)	EMISSION LEVEL (dBuV/m)	LIMIT (dBuV/m)	MARGIN (dB)	ANTENNA HEIGHT (m)	TABLE ANGLE (Degree)	RAW VALUE (dBuV)	CORRECTION FACTOR (dB/m)
1	*5310.00	99.8 PK			1.04 H	312	61.80	38.00
2	*5310.00	89.2 AV			1.04 H	312	51.20	38.00
3	5350.00	64.1 PK	74.0	-9.9	1.02 H	324	26.00	38.10
4	5350.00	46.5 AV	54.0	-7.5	1.02 H	324	8.40	38.10
5	10620.00	53.8 PK	74.0	-20.2	1.22 H	296	4.70	49.10
6	10620.00	42.4 AV	54.0	-11.6	1.22 H	296	-6.70	49.10
ANTENNA POLARITY & TEST DISTANCE: VERTICAL AT 3 M								
NO.	FREQ. (MHz)	EMISSION LEVEL (dBuV/m)	LIMIT (dBuV/m)	MARGIN (dB)	ANTENNA HEIGHT (m)	TABLE ANGLE (Degree)	RAW VALUE (dBuV)	CORRECTION FACTOR (dB/m)
1	*5310.00	104.7 PK			1.42 V	112	66.70	38.00
2	*5310.00	95.1 AV			1.42 V	112	57.10	38.00
3	5350.00	68.3 PK	74.0	-5.7	1.16 V	89	30.20	38.10
4	5350.00	51.5 AV	54.0	-2.5	1.16 V	89	13.40	38.10
5	10620.00	54.3 PK	74.0	-19.7	1.08 V	108	5.20	49.10
6	10620.00	44.9 AV	54.0	-9.1	1.08 V	108	-4.20	49.10

REMARKS:

1. Emission level (dBuV/m) = Raw Value (dBuV) + Correction Factor (dB/m).
2. Correction Factor (dB/m) = Antenna Factor (dB/m) + Cable Factor (dB).
3. The other emission levels were very low against the limit.
4. Margin value = Emission level – Limit value.
5. " * ": Fundamental frequency.



EUT TEST CONDITION		MEASUREMENT DETAIL	
CHANNEL	Channel 102	FREQUENCY RANGE	1 ~ 40GHz
INPUT POWER (SYSTEM)	120Vac, 60Hz	DETECTOR FUNCTION	Peak (PK) Average (AV)
ENVIRONMENTAL CONDITIONS	25deg. C, 68%RH	TESTED BY	Sun Lin

ANTENNA POLARITY & TEST DISTANCE: HORIZONTAL AT 3 M								
NO.	FREQ. (MHz)	EMISSION LEVEL (dBuV/m)	LIMIT (dBuV/m)	MARGIN (dB)	ANTENNA HEIGHT (m)	TABLE ANGLE (Degree)	RAW VALUE (dBuV)	CORRECTION FACTOR (dB/m)
1	5460.00	60.1 PK	74.0	-13.9	1.25 H	100	21.80	38.30
2	5460.00	46.1 AV	54.0	-7.9	1.25 H	100	7.80	38.30
3	#5470.00	62.0 PK	74.0	-12.0	1.34 H	95	23.70	38.30
4	#5470.00	49.0 AV	54.0	-5.0	1.34 H	95	10.70	38.30
5	*5510.00	98.3 PK			1.33 H	90	59.90	38.40
6	*5510.00	87.1 AV			1.33 H	90	48.70	38.40
7	11020.00	56.6 PK	74.0	-17.4	1.26 H	315	7.00	49.60
8	11020.00	44.0 AV	54.0	-10.0	1.26 H	315	-5.60	49.60
ANTENNA POLARITY & TEST DISTANCE: VERTICAL AT 3 M								
NO.	FREQ. (MHz)	EMISSION LEVEL (dBuV/m)	LIMIT (dBuV/m)	MARGIN (dB)	ANTENNA HEIGHT (m)	TABLE ANGLE (Degree)	RAW VALUE (dBuV)	CORRECTION FACTOR (dB/m)
1	5460.00	65.0 PK	74.0	-9.0	1.00 V	5	26.70	38.30
2	5460.00	50.1 AV	54.0	-3.9	1.00 V	5	11.80	38.30
3	#5470.00	67.0 PK	74.0	-7.0	1.10 V	2	28.70	38.30
4	#5470.00	52.2 AV	54.0	-1.8	1.10 V	2	13.90	38.30
5	*5510.00	105.1 PK			1.00 V	1	66.70	38.40
6	*5510.00	93.8 AV			1.00 V	1	55.40	38.40
7	11020.00	57.1 PK	74.0	-16.9	1.15 V	341	7.50	49.60
8	11020.00	45.7 AV	54.0	-8.3	1.15 V	341	-3.90	49.60

REMARKS:

1. Emission level (dBuV/m) = Raw Value (dBuV) + Correction Factor (dB/m).
2. Correction Factor (dB/m) = Antenna Factor (dB/m) + Cable Factor (dB).
3. The other emission levels were very low against the limit.
4. Margin value = Emission level – Limit value.
5. " * ": Fundamental frequency.
6. " # ": The radiated frequency is out of the restricted band.



A D T

EUT TEST CONDITION		MEASUREMENT DETAIL	
CHANNEL	Channel 110	FREQUENCY RANGE	1 ~ 40GHz
INPUT POWER (SYSTEM)	120Vac, 60Hz	DETECTOR FUNCTION	Peak (PK) Average (AV)
ENVIRONMENTAL CONDITIONS	25deg. C, 68%RH	TESTED BY	Sun Lin

ANTENNA POLARITY & TEST DISTANCE: HORIZONTAL AT 3 M								
NO.	FREQ. (MHz)	EMISSION LEVEL (dBuV/m)	LIMIT (dBuV/m)	MARGIN (dB)	ANTENNA HEIGHT (m)	TABLE ANGLE (Degree)	RAW VALUE (dBuV)	CORRECTION FACTOR (dB/m)
1	*5550.00	99.0 PK			1.15 H	90	60.60	38.40
2	*5550.00	88.5 AV			1.15 H	90	50.10	38.40
3	11100.00	55.4 PK	74.0	-18.6	1.08 H	263	5.90	49.50
4	11100.00	43.1 AV	54.0	-10.9	1.08 H	263	-6.40	49.50
ANTENNA POLARITY & TEST DISTANCE: VERTICAL AT 3 M								
NO.	FREQ. (MHz)	EMISSION LEVEL (dBuV/m)	LIMIT (dBuV/m)	MARGIN (dB)	ANTENNA HEIGHT (m)	TABLE ANGLE (Degree)	RAW VALUE (dBuV)	CORRECTION FACTOR (dB/m)
1	*5550.00	104.9 PK			1.00 V	3	66.50	38.40
2	*5550.00	93.8 AV			1.00 V	3	55.40	38.40
3	11100.00	56.9 PK	74.0	-17.1	1.03 V	269	7.40	49.50
4	11100.00	44.5 AV	54.0	-9.5	1.03 V	269	-5.00	49.50

REMARKS:

1. Emission level (dBuV/m) = Raw Value (dBuV) + Correction Factor (dB/m).
2. Correction Factor (dB/m) = Antenna Factor (dB/m) + Cable Factor (dB).
3. The other emission levels were very low against the limit.
4. Margin value = Emission level – Limit value.
5. " * ": Fundamental frequency.



A D T

EUT TEST CONDITION		MEASUREMENT DETAIL	
CHANNEL	Channel 134	FREQUENCY RANGE	1 ~ 40GHz
INPUT POWER (SYSTEM)	120Vac, 60Hz	DETECTOR FUNCTION	Peak (PK) Average (AV)
ENVIRONMENTAL CONDITIONS	25deg. C, 68%RH	TESTED BY	Sun Lin

ANTENNA POLARITY & TEST DISTANCE: HORIZONTAL AT 3 M								
NO.	FREQ. (MHz)	EMISSION LEVEL (dBuV/m)	LIMIT (dBuV/m)	MARGIN (dB)	ANTENNA HEIGHT (m)	TABLE ANGLE (Degree)	RAW VALUE (dBuV)	CORRECTION FACTOR (dB/m)
1	*5670.00	103.8 PK			1.20 H	95	65.20	38.60
2	*5670.00	91.6 AV			1.20 H	95	53.00	38.60
3	#5725.00	59.3 PK	74.0	-14.7	1.15 H	100	20.60	38.70
4	#5725.00	46.7 AV	54.0	-7.3	1.15 H	100	8.00	38.70
5	11340.00	56.9 PK	74.0	-17.1	1.25 H	247	7.40	49.50
6	11340.00	43.6 AV	54.0	-10.4	1.25 H	247	-5.90	49.50
ANTENNA POLARITY & TEST DISTANCE: VERTICAL AT 3 M								
NO.	FREQ. (MHz)	EMISSION LEVEL (dBuV/m)	LIMIT (dBuV/m)	MARGIN (dB)	ANTENNA HEIGHT (m)	TABLE ANGLE (Degree)	RAW VALUE (dBuV)	CORRECTION FACTOR (dB/m)
1	*5670.00	104.4 PK			1.00 V	85	65.80	38.60
2	*5670.00	93.7 AV			1.00 V	85	55.10	38.60
3	#5725.00	64.3 PK	74.0	-9.7	1.32 V	86	25.60	38.70
4	#5725.00	50.6 AV	54.0	-3.4	1.32 V	86	11.90	38.70
5	11340.00	55.7 PK	74.0	-18.3	1.30 V	245	6.20	49.50
6	11340.00	43.2 AV	54.0	-10.8	1.30 V	245	-6.30	49.50

REMARKS:

1. Emission level (dBuV/m) = Raw Value (dBuV) + Correction Factor (dB/m).
2. Correction Factor (dB/m) = Antenna Factor (dB/m) + Cable Factor (dB).
3. The other emission levels were very low against the limit.
4. Margin value = Emission level – Limit value.
5. " * ": Fundamental frequency.
6. " # ": The radiated frequency is out of the restricted band.



802.11ac (80MHz)

EUT TEST CONDITION		MEBSUREMENT DETBIL	
CHBNNEL	Channel 42	FREQUENCY RBNGE	1 ~ 40GHz
INPUT POWER (SYSTEM)	120Vac, 60Hz	DETECTOR FUNCTION	Peak (PK) Average (AV)
ENVIRONMENTBL CONDITIONS	25deg. C, 68%RH	TESTED BY	Martin Lee

ANTENNA POLARITY & TEST DISTANCE: HORIZONTAL AT 3 M								
NO.	FREQ. (MHz)	EMISSION LEVEL (dBuV/m)	LIMIT (dBuV/m)	MARGIN (dB)	ANTENNA HEIGHT (m)	TABLE ANGLE (Degree)	RAW VALUE (dBuV)	CORRECTION FACTOR (dB/m)
1	5150.00	54.8 PK	74.0	-19.2	1.15 H	95	17.00	37.80
2	5150.00	43.1 AV	54.0	-10.9	1.15 H	95	5.30	37.80
3	*5210.00	95.0 PK			1.14 H	91	57.10	37.90
4	*5210.00	84.9 AV			1.14 H	91	47.00	37.90
5	#10420.00	55.4 PK	74.0	-18.6	1.00 H	214	6.50	48.90
6	#10420.00	42.7 AV	54.0	-11.3	1.00 H	214	-6.20	48.90
ANTENNA POLARITY & TEST DISTANCE: VERTICAL AT 3 M								
NO.	FREQ. (MHz)	EMISSION LEVEL (dBuV/m)	LIMIT (dBuV/m)	MARGIN (dB)	ANTENNA HEIGHT (m)	TABLE ANGLE (Degree)	RAW VALUE (dBuV)	CORRECTION FACTOR (dB/m)
1	5150.00	54.8 PK	74.0	-19.2	1.00 V	200	17.00	37.80
2	5150.00	42.5 AV	54.0	-11.5	1.00 V	200	4.70	37.80
3	*5210.00	99.3 PK			1.00 V	198	61.40	37.90
4	*5210.00	88.5 AV			1.00 V	198	50.60	37.90
5	#10420.00	54.5 PK	74.0	-19.5	1.20 V	33	5.60	48.90
6	#10420.00	43.3 AV	54.0	-10.7	1.20 V	33	-5.60	48.90

REMARKS:

1. Emission level (dBuV/m) = Raw Value (dBuV) + Correction Factor (dB/m).
2. Correction Factor (dB/m) = Antenna Factor (dB/m) + Cable Factor (dB).
3. The other emission levels were very low against the limit.
4. Margin value = Emission level – Limit value.
5. " * ": Fundamental frequency.
6. " # ": The radiated frequency is out of the restricted band.



EUT TEST CONDITION		MEASUREMENT DETAIL	
CHANNEL	Channel 58	FREQUENCY RANGE	1 ~ 40GHz
INPUT POWER (SYSTEM)	120Vac, 60Hz	DETECTOR FUNCTION	Peak (PK) Average (AV)
ENVIRONMENTAL CONDITIONS	25deg. C, 68%RH	TESTED BY	Martin Lee

ANTENNA POLARITY & TEST DISTANCE: HORIZONTAL AT 3 M								
NO.	FREQ. (MHz)	EMISSION LEVEL (dBuV/m)	LIMIT (dBuV/m)	MARGIN (dB)	ANTENNA HEIGHT (m)	TABLE ANGLE (Degree)	RAW VALUE (dBuV)	CORRECTION FACTOR (dB/m)
1	*5290.00	96.7 PK			1.22 H	131	58.70	38.00
2	*5290.00	86.5 AV			1.22 H	131	48.50	38.00
3	5350.00	56.6 PK	74.0	-17.4	1.22 H	130	18.50	38.10
4	5350.00	47.8 AV	54.0	-6.2	1.22 H	130	9.70	38.10
5	#10580.00	56.6 PK	74.0	-17.4	1.33 H	24	7.60	49.00
6	#10580.00	44.0 AV	54.0	-10.0	1.33 H	24	-5.00	49.00
ANTENNA POLARITY & TEST DISTANCE: VERTICAL AT 3 M								
NO.	FREQ. (MHz)	EMISSION LEVEL (dBuV/m)	LIMIT (dBuV/m)	MARGIN (dB)	ANTENNA HEIGHT (m)	TABLE ANGLE (Degree)	RAW VALUE (dBuV)	CORRECTION FACTOR (dB/m)
1	*5290.00	100.1 PK			1.00 V	191	62.10	38.00
2	*5290.00	90.1 AV			1.00 V	191	52.10	38.00
3	5350.00	63.5 PK	74.0	-10.5	1.01 V	334	25.40	38.10
4	5350.00	51.2 AV	54.0	-2.8	1.01 V	334	13.10	38.10
5	#10580.00	55.5 PK	74.0	-18.5	1.22 V	325	6.50	49.00
6	#10580.00	43.6 AV	54.0	-10.4	1.22 V	325	-5.40	49.00

REMARKS:

1. Emission level (dBuV/m) = Raw Value (dBuV) + Correction Factor (dB/m).
2. Correction Factor (dB/m) = Antenna Factor (dB/m) + Cable Factor (dB).
3. The other emission levels were very low against the limit.
4. Margin value = Emission level – Limit value.
5. " * " : Fundamental frequency.
6. " # " : The radiated frequency is out of the restricted band.



A D T

EUT TEST CONDITION		MEBSUREMENT DETBIL	
CHBNNEL	Channel 106	FREQUENCY RBNGE	1 ~ 40GHz
INPUT POWER (SYSTEM)	120Vac, 60Hz	DETECTOR FUNCTION	Peak (PK) Average (AV)
ENVIRONMENTBL CONDITIONS	25deg. C, 68%RH	TESTED BY	Martin Lee

ANTENNA POLARITY & TEST DISTANCE: HORIZONTAL AT 3 M								
NO.	FREQ. (MHz)	EMISSION LEVEL (dBuV/m)	LIMIT (dBuV/m)	MARGIN (dB)	ANTENNA HEIGHT (m)	TABLE ANGLE (Degree)	RAW VALUE (dBuV)	CORRECTION FACTOR (dB/m)
1	5460.00	60.1 PK	74.0	-13.9	1.33 H	102	21.80	38.30
2	5460.00	45.8 AV	54.0	-8.2	1.33 H	102	7.50	38.30
3	#5470.00	63.3 PK	74.0	-10.7	1.41 H	88	25.00	38.30
4	#5470.00	49.2 AV	54.0	-4.8	1.41 H	88	10.90	38.30
5	*5530.00	97.4 PK			1.37 H	90	59.00	38.40
6	*5530.00	86.8 AV			1.37 H	90	48.40	38.40
7	11060.00	54.9 PK	74.0	-19.1	1.29 H	158	5.30	49.60
8	11060.00	44.3 AV	54.0	-9.7	1.29 H	158	-5.30	49.60
ANTENNA POLARITY & TEST DISTANCE: VERTICAL AT 3 M								
NO.	FREQ. (MHz)	EMISSION LEVEL (dBuV/m)	LIMIT (dBuV/m)	MARGIN (dB)	ANTENNA HEIGHT (m)	TABLE ANGLE (Degree)	RAW VALUE (dBuV)	CORRECTION FACTOR (dB/m)
1	5460.00	63.5 PK	74.0	-10.5	1.08 V	155	25.20	38.30
2	5460.00	51.8 AV	54.0	-2.2	1.08 V	155	13.50	38.30
3	#5470.00	66.4 PK	74.0	-7.6	1.07 V	145	28.10	38.30
4	#5470.00	52.5 AV	54.0	-1.5	1.07 V	145	14.20	38.30
5	*5530.00	98.8 PK			1.14 V	86	60.40	38.40
6	*5530.00	87.4 AV			1.14 V	86	49.00	38.40
7	11060.00	55.0 PK	74.0	-19.0	1.20 V	158	5.40	49.60
8	11060.00	44.2 AV	54.0	-9.8	1.20 V	158	-5.40	49.60

REMARKS:

1. Emission level (dBuV/m) = Raw Value (dBuV) + Correction Factor (dB/m).
2. Correction Factor (dB/m) = Antenna Factor (dB/m) + Cable Factor (dB).
3. The other emission levels were very low against the limit.
4. Margin value = Emission level – Limit value.
5. " * ": Fundamental frequency.
6. " # ": The radiated frequency is out of the restricted band.

BELOW 1GHz WORST-CASE DATA : 802.11n (20MHz)

EUT TEST CONDITION		MEASUREMENT DETAIL	
CHANNEL	Channel 52	FREQUENCY RANGE	Below 1000MHz
INPUT POWER (SYSTEM)	120Vac, 60Hz	DETECTOR FUNCTION	Quasi-Peak
ENVIRONMENTAL CONDITIONS	25deg. C, 68%RH	TESTED BY	Sun Lin

ANTENNA POLARITY & TEST DISTANCE: HORIZONTAL AT 3 M								
NO.	FREQ. (MHz)	EMISSION LEVEL (dBuV/m)	LIMIT (dBuV/m)	MARGIN (dB)	ANTENNA HEIGHT (m)	TABLE ANGLE (Degree)	RAW VALUE (dBuV)	CORRECTION FACTOR (dB/m)
1	208.48	36.7 QP	43.5	-6.8	1.25 H	91	25.50	11.20
2	280.26	34.9 QP	46.0	-11.1	1.00 H	298	20.80	14.10
3	317.12	36.8 QP	46.0	-9.2	1.00 H	37	21.50	15.30
4	418.00	35.5 QP	46.0	-10.5	2.00 H	99	17.70	17.80
5	629.46	37.0 QP	46.0	-9.0	1.00 H	132	14.30	22.70
6	697.36	35.1 QP	46.0	-10.9	1.00 H	144	11.80	23.30
ANTENNA POLARITY & TEST DISTANCE: VERTICAL AT 3 M								
NO.	FREQ. (MHz)	EMISSION LEVEL (dBuV/m)	LIMIT (dBuV/m)	MARGIN (dB)	ANTENNA HEIGHT (m)	TABLE ANGLE (Degree)	RAW VALUE (dBuV)	CORRECTION FACTOR (dB/m)
1	280.26	31.0 QP	46.0	-15.0	1.24 V	177	16.90	14.10
2	321.00	28.7 QP	46.0	-17.3	1.24 V	75	13.30	15.40
3	400.54	34.5 QP	46.0	-11.5	1.50 V	177	17.10	17.40
4	419.94	31.3 QP	46.0	-14.7	1.00 V	17	13.40	17.90
5	629.46	35.6 QP	46.0	-10.4	1.50 V	16	12.90	22.70
6	825.40	37.9 QP	46.0	-8.1	1.24 V	319	12.50	25.40

REMARKS:

1. Emission level (dBuV/m) = Raw Value (dBuV) + Correction Factor (dB/m).
2. Correction Factor (dB/m) = Antenna Factor (dB/m) + Cable Factor (dB).
3. The other emission levels were very low against the limit.
4. Margin value = Emission level – Limit value.



802.11n (40MHz)

EUT TEST CONDITION		MEASUREMENT DETAIL	
CHANNEL	Channel 110	FREQUENCY RANGE	Below 1000MHz
INPUT POWER (SYSTEM)	120Vac, 60Hz	DETECTOR FUNCTION	Quasi-Peak
ENVIRONMENTAL CONDITIONS	25deg. C, 68%RH	TESTED BY	Sun Lin

ANTENNA POLARITY & TEST DISTANCE: HORIZONTAL AT 3 M								
NO.	FREQ. (MHz)	EMISSION LEVEL (dBuV/m)	LIMIT (dBuV/m)	MARGIN (dB)	ANTENNA HEIGHT (m)	TABLE ANGLE (Degree)	RAW VALUE (dBuV)	CORRECTION FACTOR (dB/m)
1	208.48	35.2 QP	43.5	-8.3	1.00 H	308	24.00	11.20
2	278.32	35.2 QP	46.0	-10.8	1.00 H	95	21.10	14.10
3	321.00	36.1 QP	46.0	-9.9	1.00 H	25	20.70	15.40
4	418.00	33.7 QP	46.0	-12.3	1.99 H	97	15.90	17.80
5	627.52	35.6 QP	46.0	-10.4	1.24 H	280	13.00	22.60
6	701.24	33.5 QP	46.0	-12.5	1.24 H	263	10.10	23.40
ANTENNA POLARITY & TEST DISTANCE: VERTICAL AT 3 M								
NO.	FREQ. (MHz)	EMISSION LEVEL (dBuV/m)	LIMIT (dBuV/m)	MARGIN (dB)	ANTENNA HEIGHT (m)	TABLE ANGLE (Degree)	RAW VALUE (dBuV)	CORRECTION FACTOR (dB/m)
1	280.26	31.9 QP	46.0	-14.1	1.50 V	181	17.80	14.10
2	400.54	35.0 QP	46.0	-11.0	1.25 V	176	17.60	17.40
3	419.94	30.8 QP	46.0	-15.2	1.25 V	16	12.90	17.90
4	629.46	36.2 QP	46.0	-9.8	1.50 V	17	13.50	22.70
5	699.30	33.1 QP	46.0	-12.9	1.25 V	16	9.80	23.30
6	825.40	37.1 QP	46.0	-8.9	1.25 V	277	11.70	25.40

REMARKS:

1. Emission level (dBuV/m) = Raw Value (dBuV) + Correction Factor (dB/m).
2. Correction Factor (dB/m) = Antenna Factor (dB/m) + Cable Factor (dB).
3. The other emission levels were very low against the limit.
4. Margin value = Emission level – Limit value.

4.2 CONDUCTED EMISSION MEASUREMENT

4.2.1 LIMITS OF CONDUCTED EMISSION MEASUREMENT

FREQUENCY OF EMISSION (MHz)	CONDUCTED LIMIT (dB μ V)	
	Quasi-peak	Average
0.15 ~ 0.5	66 to 56	56 to 46
0.5 ~ 5	56	46
5 ~ 30	60	50

- NOTE:**
1. The lower limit shall apply at the transition frequencies.
 2. The limit decreases in line with the logarithm of the frequency in the range of 0.15 to 0.50MHz.
 3. All emanations from a class A/B digital device or system, including any network of conductors and apparatus connected thereto, shall not exceed the level of field strengths specified above.

4.2.2 TEST INSTRUMENTS

DESCRIPTION & MANUFACTURER	MODEL NO.	SERIAL NO.	DATE OF CALIBRATION	DUE DATE OF CALIBRATION
Test Receiver ROHDE & SCHWARZ	ESCS30	100289	Nov. 16, 2012	Nov. 15, 2013
RF signal cable Woken	5D-FB	Cable-HYC01-01	Dec. 28, 2012	Dec. 27, 2013
LISN ROHDE & SCHWARZ (Peripheral)	ESH3-Z5	100312	Jul. 02, 2012	Jul. 01, 2013
LISN ROHDE & SCHWARZ (EUT)	ESH3-Z5	835239/001	Feb. 07, 2012	Feb. 06, 2013
Software ADT	BV ADT_Cond_ V7.3.7.3	NA	NA	NA

- NOTE:**
1. The calibration interval of the above test instruments is 12 months and the calibrations are traceable to NML/ROC and NIST/USA.
 2. The test was performed in HwaYa Shielded Room 1.
 3. The VCCI Site Registration No. is C-2040.

4.2.3 TEST PROCEDURES

- The EUT was placed 0.4 meters from the conducting wall of the shielded room with EUT being connected to the power mains through a line impedance stabilization network (LISN). Other support units were connected to the power mains through another LISN. The two LISNs provide 50 ohm/ 50uH of coupling impedance for the measuring instrument.
- Both lines of the power mains connected to the EUT were checked for maximum conducted interference.
- The frequency range from 150kHz to 30MHz was searched. Emission levels under (Limit - 20dB) was not recorded.

NOTE: All modes of operation were investigated and the worst-case emissions are reported.

4.2.4 DEVIATION FROM TEST STANDARD

No deviation.

4.2.5 TEST SETUP

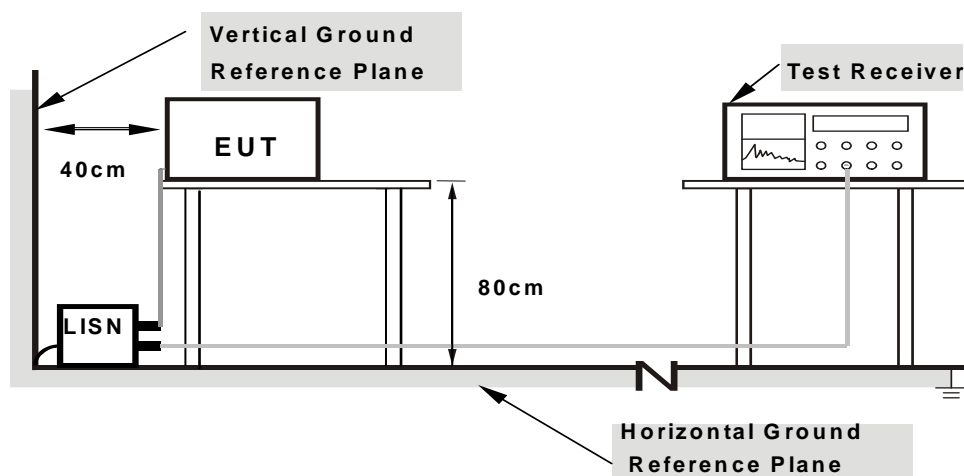

- Note:**
- Support units were connected to second LISN.
 - Both of LISNs (AMN) are 80 cm from EUT and at least 80 from other units and other metal planes

For the actual test configuration, please refer to the attached file (Test Setup Photo).

4.2.6 EUT OPERATING CONDITIONS

Same as 4.1.6.

4.2.7 TEST RESULTS

CONDUCTED WORST-CASE DATA : 802.11n (20MHz)

PHASE	Line 1	6dB BANDWIDTH	9kHz
CHANNEL	Channel 52		

No	Freq. [MHz]	Corr. Factor (dB)	Reading Value		Emission Level		Limit		Margin	
			[dB (uV)]		[dB (uV)]		[dB (uV)]		(dB)	
			Q.P.	AV.	Q.P.	AV.	Q.P.	AV.	Q.P.	AV.
1	0.16967	0.18	45.12	25.15	45.30	25.33	64.98	54.98	-19.68	-29.65
2	0.57620	0.21	35.82	20.73	36.03	20.94	56.00	46.00	-19.97	-25.06
3	1.29172	0.23	30.48	17.04	30.71	17.27	56.00	46.00	-25.29	-28.73
4	2.07763	0.26	29.66	17.98	29.92	18.24	56.00	46.00	-26.08	-27.76
5	10.13223	0.58	32.97	24.85	33.55	25.43	60.00	50.00	-26.45	-24.57
6	13.02563	0.68	33.95	23.55	34.63	24.23	60.00	50.00	-25.37	-25.77

- REMARKS:**
1. Q.P. and AV. are abbreviations of quasi-peak and average individually.
 2. The emission levels of other frequencies were very low against the limit.
 3. Margin value = Emission level - Limit value
 4. Correction factor = Insertion loss + Cable loss
 5. Emission Level = Correction Factor + Reading Value.

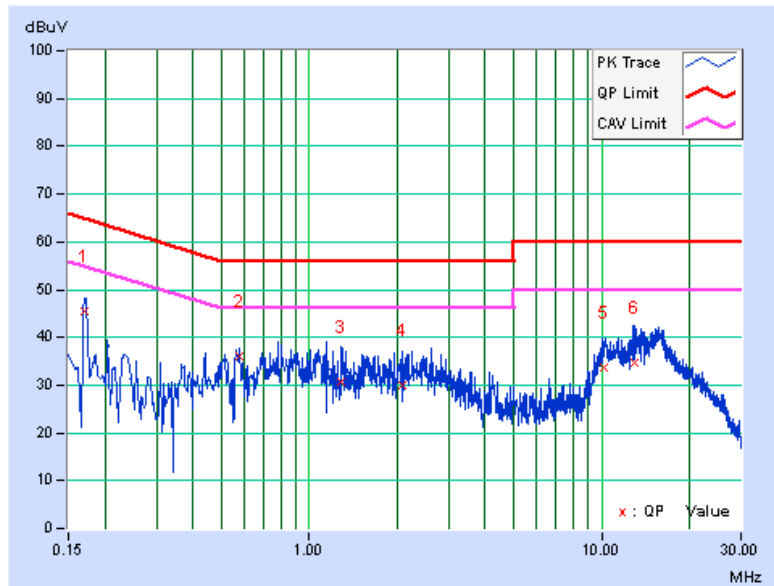



A D T

PHASE	Line 2	6dB BANDWIDTH	9kHz
CHANNEL	Channel 52		

No	Freq. [MHz]	Corr. Factor (dB)	Reading Value		Emission Level		Limit		Margin	
			[dB (uV)]		[dB (uV)]		[dB (uV)]		(dB)	
			Q.P.	AV.	Q.P.	AV.	Q.P.	AV.	Q.P.	AV.
1	0.16967	0.27	45.31	25.57	45.58	25.84	64.98	54.98	-19.40	-29.14
2	0.56716	0.30	34.26	20.28	34.56	20.58	56.00	46.00	-21.44	-25.42
3	1.02193	0.31	33.26	18.28	33.57	18.59	56.00	46.00	-22.43	-27.41
4	2.55074	0.39	30.73	20.25	31.12	20.64	56.00	46.00	-24.88	-25.36
5	10.24953	0.67	33.50	25.74	34.17	26.41	60.00	50.00	-25.83	-23.59
6	15.78609	0.87	39.52	36.67	40.39	37.54	60.00	50.00	-19.61	-12.46

- REMARKS:**
1. Q.P. and AV. are abbreviations of quasi-peak and average individually.
 2. The emission levels of other frequencies were very low against the limit.
 3. Margin value = Emission level - Limit value
 4. Correction factor = Insertion loss + Cable loss
 5. Emission Level = Correction Value + Reading Value.

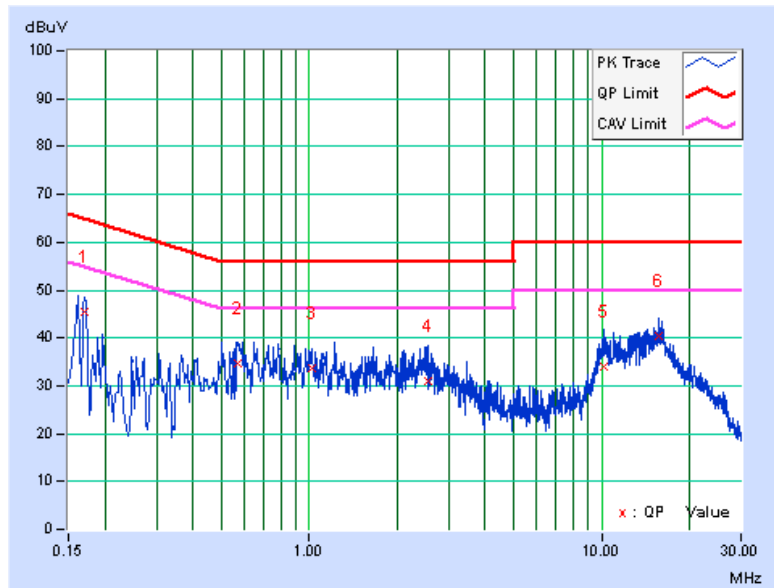



A D T

802.11n (40MHz)

PHASE	Line 1	6dB BANDWIDTH	9kHz
CHANNEL	Channel 110		

No	Freq. [MHz]	Corr. Factor (dB)	Reading Value		Emission Level		Limit		Margin	
			[dB (uV)]		[dB (uV)]		[dB (uV)]		(dB)	
			Q.P.	AV.	Q.P.	AV.	Q.P.	AV.	Q.P.	AV.
1	0.17328	0.18	42.79	26.36	42.97	26.54	64.80	54.80	-21.83	-28.26
2	0.57620	0.21	34.81	19.42	35.02	19.63	56.00	46.00	-20.98	-26.37
3	1.96033	0.26	30.80	18.42	31.06	18.68	56.00	46.00	-24.94	-27.32
4	4.13820	0.36	22.55	11.89	22.91	12.25	56.00	46.00	-33.09	-33.75
5	10.05012	0.58	32.19	24.80	32.77	25.38	60.00	50.00	-27.23	-24.62
6	15.74699	0.77	39.08	35.79	39.85	36.56	60.00	50.00	-20.15	-13.44

- REMARKS:**
1. Q.P. and AV. are abbreviations of quasi-peak and average individually.
 2. The emission levels of other frequencies were very low against the limit.
 3. Margin value = Emission level - Limit value
 4. Correction factor = Insertion loss + Cable loss
 5. Emission Level = Correction Factor + Reading Value.

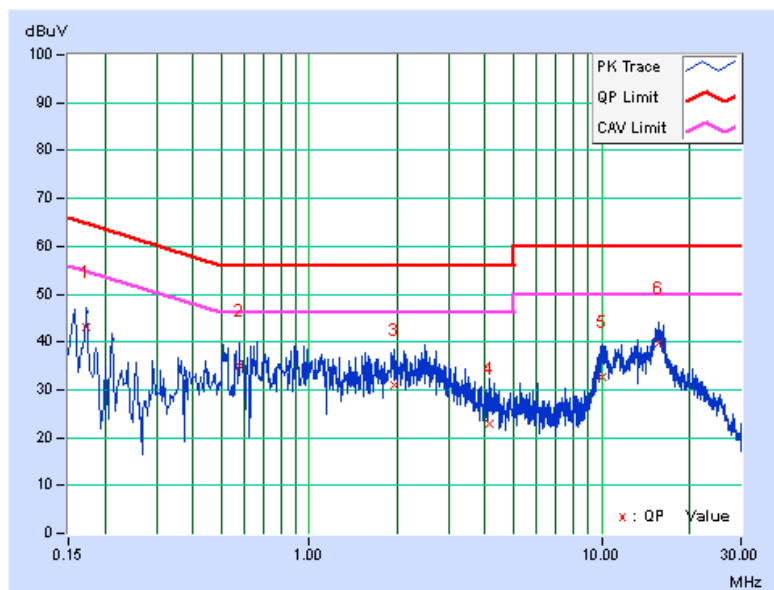



A D T

PHASE	Line 2	6dB BANDWIDTH	9kHz
CHANNEL	Channel 110		

No	Freq. [MHz]	Corr. Factor (dB)	Reading Value		Emission Level		Limit		Margin	
			[dB (uV)]		[dB (uV)]		[dB (uV)]		(dB)	
			Q.P.	AV.	Q.P.	AV.	Q.P.	AV.	Q.P.	AV.
1	0.16569	0.27	47.02	27.60	47.29	27.87	65.17	55.17	-17.89	-27.31
2	0.36505	0.30	32.20	17.53	32.50	17.83	58.61	48.61	-26.11	-30.78
3	0.72084	0.31	36.25	21.46	36.56	21.77	56.00	46.00	-19.44	-24.23
4	2.41780	0.38	30.78	19.94	31.16	20.32	56.00	46.00	-24.84	-25.68
5	10.06967	0.66	32.77	25.12	33.43	25.78	60.00	50.00	-26.57	-24.22
6	15.36772	0.85	38.14	34.64	38.99	35.49	60.00	50.00	-21.01	-14.51

- REMARKS:**
1. Q.P. and AV. are abbreviations of quasi-peak and average individually.
 2. The emission levels of other frequencies were very low against the limit.
 3. Margin value = Emission level - Limit value
 4. Correction factor = Insertion loss + Cable loss
 5. Emission Level = Correction Factor + Reading Value.

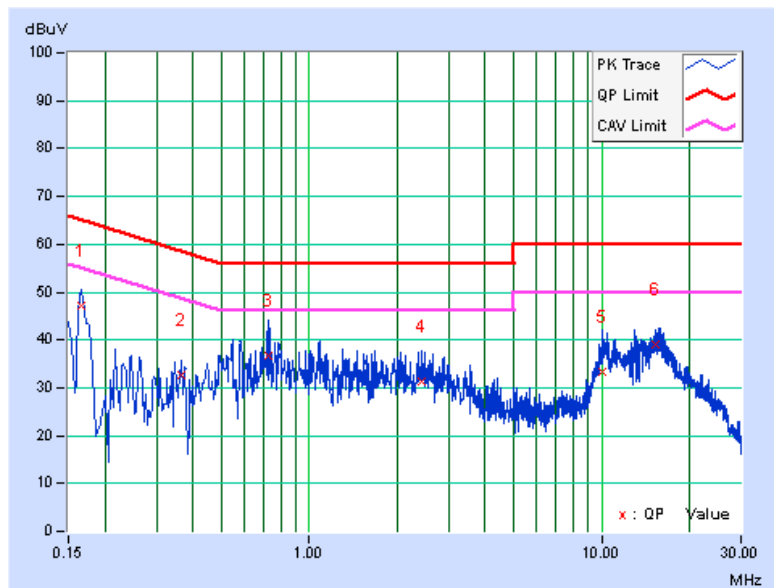

4.3 PEAK TRANSMIT POWER MEASUREMENT

4.3.1 LIMITS OF PEAK TRANSMIT POWER MEASUREMENT

FREQUENCY BAND	LIMIT
5.150 ~ 5.250GHz	The lesser of 50mW (17dBm) or 4dBm + 10logB
5.250 ~ 5.350GHz	The lesser of 250mW (24dBm) or 11dBm + 10logB
5.470 ~ 5.725GHz	The lesser of 250mW (24dBm) or 11dBm + 10logB

NOTE: Where B is the 26dB emission bandwidth in MHz.

Per KDB 662911 D01 Multiple Transmitter Output v01r02 Method of conducted output power measurement on IEEE 802.11 devices,

Array Gain = 0 dB (i.e., no array gain) for NANT ≤ 4;

Array Gain = 0 dB (i.e., no array gain) for channel widths ≥ 40 MHz for any NANT;

Array Gain = 5 log(NANT/NSS) dB or 3 dB, whichever is less for 20-MHz channel widths with NANT ≥ 5.

For power measurements on all other devices: Array Gain = 10 log(NANT/NSS) dB.

4.3.2 TEST SETUP

FOR POWER OUTPUT MEASUREMENT

For 802.11a, 802.11n (20MHz), 802.11n (40MHz)

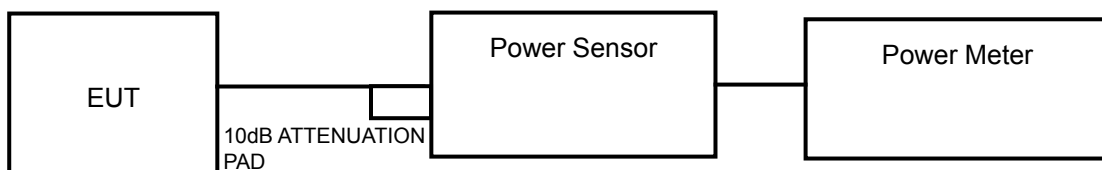

For 802.11ac (80MHz)

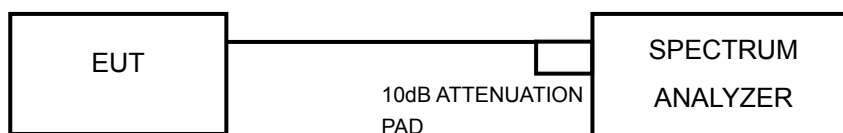

FOR 26dB BANDWIDTH

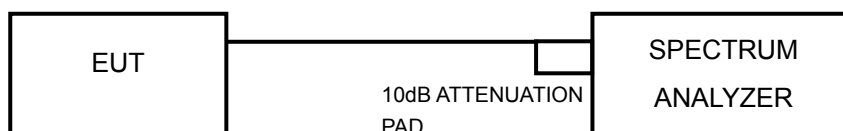

4.3.3 TEST INSTRUMENTS

Refer to section 4.1.3 to get information of above instrument.

4.3.4 TEST PROCEDURE

FOR AVERAGE POWER MEASUREMENT

For 802.11a, 802.11n (20MHz), 802.11n (40MHz)

Method PM is used to perform output power measurement, trigger and gating function of wide band power meter is enabled to measure max output power of TX on burst. Duty factor is not added to measured value.

For 802.11ac (80MHz)

Method SA-1

- 1) Set span to encompass the entire emission bandwidth (EBW) of the signal.
- 2) Set RBW = 1 MHz.
- 3) Set VBW \geq 3 MHz.
- 4) Number of points in sweep \geq 2 Span / RBW.
- 5) Sweep time = auto.
- 6) Set trigger to free run (duty cycle \geq 98 percent); Set video trigger (duty cycle $<$ 98 percent)
- 7) Detector = RMS.
- 8) Trace average at least 100 traces in power averaging mode
- 9) Compute power by integrating the spectrum across the 26 dB EBW of the signal.

FOR 26dB BANDWIDTH

- 1) Set RBW = approximately 1% of the emission bandwidth.
- 2) Set the VBW $>$ RBW.
- 3) Detector = Peak.
- 4) Trace mode = max hold.
- 5) Measure the maximum width of the emission that is 26 dB down from the peak of the emission. Compare this with the RBW setting of the analyzer. Readjust RBW and repeat measurement as needed until the RBW/EBW ratio is approximately 1%.

4.3.5 DEVIATION FROM TEST STANDARD

No deviation.

4.3.6 EUT OPERATING CONDITIONS

The software provided by client to enable the EUT under transmission condition continuously at specific channel frequencies individually.

4.3.7 TEST RESULTS

POWER OUTPUT:

802.11a

CHANNEL	CHANNEL FREQUENCY (MHz)	AVERAGE POWER (mW)	AVERAGE POWER (dBm)	POWER LIMIT (dBm)	PASS/FAIL
36	5180	33.420	15.24	17	PASS
40	5200	34.514	15.38	17	PASS
48	5240	32.211	15.08	17	PASS
52	5260	94.189	19.74	24	PASS
60	5300	113.240	20.54	24	PASS
64	5320	94.189	19.74	24	PASS
100	5500	125.314	20.98	24	PASS
116	5580	125.603	20.99	24	PASS
140	5700	94.189	19.74	24	PASS

802.11n (20MHz)

CHAN.	CHAN. FREQ. (MHz)	AVERAGE POWER (dBm)		TOTAL POWER (mW)	TOTAL POWER (dBm)	POWER LIMIT (dBm)	PASS / FAIL
		CHAIN 0	CHAIN 1				
36	5180	12.85	12.84	38.506	15.86	17	PASS
40	5200	12.78	12.64	37.332	15.72	17	PASS
48	5240	12.56	12.45	35.609	15.52	17	PASS
52	5260	19.41	19.28	172.020	22.36	24	PASS
60	5300	19.18	19.50	171.919	22.35	24	PASS
64	5320	16.31	16.17	84.156	19.25	24	PASS
100	5500	19.14	19.05	162.388	22.11	24	PASS
116	5580	19.02	18.96	158.504	22.00	24	PASS
140	5700	18.85	17.74	136.165	21.34	24	PASS



802.11n (40MHz)

CHAN.	CHAN. FREQ. (MHz)	AVERAGE POWER (dBm)		TOTAL POWER (mW)	TOTAL POWER (dBm)	POWER LIMIT (dBm)	PASS / FAIL
		CHAIN 0	CHAIN 1				
38	5190	13.24	13.47	43.319	16.37	17	PASS
46	5230	13.65	13.27	44.406	16.47	17	PASS
54	5270	19.32	19.04	165.675	22.19	24	PASS
62	5310	15.54	15.24	69.230	18.40	24	PASS
102	5510	17.72	17.64	117.232	20.69	24	PASS
110	5550	19.58	19.64	182.827	22.62	24	PASS
134	5670	19.05	18.63	153.299	21.86	24	PASS

802.11ac (80MHz)

CHAN.	CHAN. FREQ. (MHz)	AVERAGE POWER (dBm)		TOTAL POWER (mW)	TOTAL POWER (dBm)	POWER LIMIT (dBm)	PASS / FAIL
		CHAIN 0	CHAIN 1				
42	5210	13.56	13.84	46.909	16.71	17	PASS
58	5290	16.64	16.34	89.185	19.50	24	PASS
106	5530	15.62	15.14	69.134	18.40	24	PASS



26dB BANDWIDTH:

802.11a

CHANNEL	CHANNEL FREQUENCY (MHz)	26dBc BANDWIDTH (MHz)	PASS / FAIL
36	5180	20.48	PASS
40	5200	20.50	PASS
48	5240	20.49	PASS
52	5260	39.20	PASS
60	5300	40.25	PASS
64	5320	23.90	PASS
100	5500	40.22	PASS
116	5580	40.09	PASS
140	5700	40.21	PASS

802.11n (20MHz)

CHANNEL	CHANNEL FREQUENCY (MHz)	26dBc BANDWIDTH (MHz)		PASS / FAIL
		CHAIN 0	CHAIN 1	
36	5180	20.43	20.01	PASS
40	5200	20.62	20.11	PASS
48	5240	20.43	20.29	PASS
52	5260	27.12	28.00	PASS
60	5300	26.46	33.91	PASS
64	5320	23.09	33.06	PASS
100	5500	34.94	21.70	PASS
116	5580	37.35	27.28	PASS
140	5700	37.64	29.17	PASS

802.11n (40MHz)

CHANNEL	CHANNEL FREQUENCY (MHz)	26dBc BANDWIDTH (MHz)		PASS / FAIL
		CHAIN 0	CHAIN 1	
38	5190	43.20	43.72	PASS
46	5230	43.58	43.68	PASS
54	5270	68.67	91.07	PASS
62	5310	43.97	43.68	PASS
102	5510	62.37	56.39	PASS
110	5550	84.36	84.34	PASS
134	5670	63.75	69.26	PASS



A D T

802.11ac (80MHz)

CHANNEL	CHANNEL FREQUENCY (MHz)	26dBc BANDWIDTH (MHz)		PASS / FAIL
		CHAIN 0	CHAIN 1	
42	5210	82.68	83.49	PASS
58	5290	85.87	92.56	PASS
106	5530	85.63	85.30	PASS

EUT HIGHEST AND LOWEST CONDUCTED POWER

802.11a

FREQUENCY BAND (MHz)	MAX. POWER		MIN. POWER	
	OUTPUT POWER (mW)	OUTPUT POWER (dBm)	OUTPUT POWER (mW)	OUTPUT POWER (dBm)
5250~5350	113.240	20.54	28.445	14.54
5470~5725	125.603	20.99	31.550	14.99

NOTE: Manufacturer provides Transmit Power Control description to meet this requirement.

802.11n (20MHz)

FREQUENCY BAND (MHz)	MAX. POWER		MIN. POWER	
	OUTPUT POWER (mW)	OUTPUT POWER (dBm)	OUTPUT POWER (mW)	OUTPUT POWER (dBm)
5250~5350	172.020	22.36	43.251	16.36
5470~5725	162.388	22.11	40.832	16.11

NOTE: Manufacturer provides Transmit Power Control description to meet this requirement.

802.11n (40MHz)

FREQUENCY BAND (MHz)	MAX. POWER		MIN. POWER	
	OUTPUT POWER (mW)	OUTPUT POWER (dBm)	OUTPUT POWER (mW)	OUTPUT POWER (dBm)
5250~5350	165.675	22.19	41.591	16.19
5470~5725	182.827	22.62	45.920	16.62

NOTE: Manufacturer provides Transmit Power Control description to meet this requirement.

802.11ac (80MHz)

FREQUENCY BAND (MHz)	MAX. POWER		MIN. POWER	
	OUTPUT POWER (mW)	OUTPUT POWER (dBm)	OUTPUT POWER (mW)	OUTPUT POWER (dBm)
5250~5350	89.185	19.50	22.387	13.50
5470~5725	69.134	18.40	17.378	12.40

NOTE: Manufacturer provides Transmit Power Control description to meet this requirement.

4.4 PEAK POWER SPECTRAL DENSITY MEASUREMENT

4.4.1 LIMITS OF PEAK POWER SPECTRAL DENSITY MEASUREMENT

FREQUENCY BAND	LIMIT
5.150 ~ 5.250GHz	4dBm
5.250 ~ 5.350GHz	11dBm
5.470 ~ 5.725GHz	11dBm

4.4.2 TEST SETUP

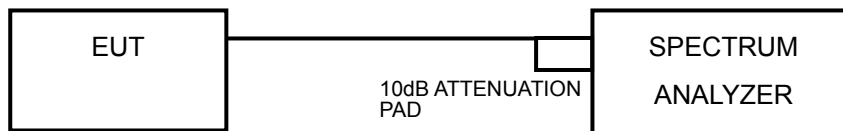

4.4.3 TEST INSTRUMENTS

Refer to section 4.1.3 to get information of above instrument.

4.4.4 TEST PROCEDURES

- 1) Set span to encompass the entire emission bandwidth (EBW) of the signal.
- 2) Set RBW = 30 KHz, Set VBW \geq 1 MHz, Detector = RMS
- 3) Set Channel power measure = 1MHz
- 4) Sweep time = auto, trigger set to "free run".
- 5) Trace average at least 100 traces in power averaging mode.
- 6) Record the max value

4.4.5 DEVIATION FROM TEST STANDARD

No deviation.

4.4.6 EUT OPERATING CONDITIONS

Same as 4.3.6.

4.4.7 TEST RESULTS

802.11a

CHANNEL	FREQUENCY (MHz)	PSD (dBm)	MAXIMUM LIMIT (dBm)	PASS/FAIL
36	5180	3.50	4	PASS
40	5200	3.44	4	PASS
48	5240	3.54	4	PASS
52	5260	9.21	11	PASS
60	5300	9.17	11	PASS
64	5320	6.11	11	PASS
100	5500	9.08	11	PASS
116	5580	9.24	11	PASS
140	5700	9.15	11	PASS

802.11n (20MHz)

CHAN.	CHAN. FREQ. (MHz)	PSD (dBm)		TOTAL POWER DENSITY (dBm)	MAX. LIMIT (dBm)	PASS / FAIL
		CHAIN 0	CHAIN 1			
36	5180	0.24	0.41	3.34	4	PASS
40	5200	0.61	0.51	3.57	4	PASS
48	5240	0.42	0.25	3.35	4	PASS
52	5260	7.07	7.43	10.26	11	PASS
60	5300	7.35	7.18	10.28	11	PASS
64	5320	7.30	7.53	10.43	11	PASS
100	5500	7.50	7.22	10.37	11	PASS
116	5580	7.14	7.29	10.23	11	PASS
140	5700	7.11	7.43	10.28	11	PASS

NOTE: 1. Method 1 of power density measurement of KDB 662911 is using for calculating total power density. Total power density is summing entire spectra across corresponding frequency bins on the various outputs by computer.

2. For 5180~5240MHz:

Directional gain = 0dBi + 10log(2) = 3dBi < 6dBi, so the limit no need to reduced.

For 5260~5700MHz:

Directional gain = 0dBi + 10log(2) = 3dBi < 6dBi, so the limit no need to reduced.

802.11n (40MHz)

CHAN.	CHAN. FREQ. (MHz)	PSD (dBm)		TOTAL POWER DENSITY (dBm)	MAX. LIMIT (dBm)	PASS / FAIL
		CHAIN 0	CHAIN 1			
38	5190	-2.01	-1.81	1.10	4	PASS
46	5230	-1.76	-1.51	1.38	4	PASS
54	5270	5.14	5.95	8.57	11	PASS
62	5310	0.67	0.52	3.61	11	PASS
102	5510	2.93	2.56	5.76	11	PASS
110	5550	5.03	5.67	8.37	11	PASS
134	5670	2.64	2.36	5.51	11	PASS

NOTE: 1. Method 1 of power density measurement of KDB 662911 is using for calculating total power density. Total power density is summing entire spectra across corresponding frequency bins on the various outputs by computer.

2. For 5190~5230MHz:

Directional gain = 0dBi + 10log(2) = 3dBi < 6dBi, so the limit no need to reduced.

For 5270~5670MHz:

Directional gain = 0dBi + 10log(2) = 3dBi < 6dBi, so the limit no need to reduced.

802.11ac (80MHz)

CHAN.	CHAN. FREQ. (MHz)	PSD (dBm)		TOTAL POWER DENSITY (dBm)	MAX. LIMIT (dBm)	PASS / FAIL
		CHAIN 0	CHAIN 1			
42	5210	-3.44	-3.60	-0.51	4	PASS
58	5290	-0.70	-0.63	2.35	11	PASS
106	5530	-0.91	-2.42	1.41	11	PASS

NOTE: 1. Method 1 of power density measurement of KDB 662911 is using for calculating total power density. Total power density is summing entire spectra across corresponding frequency bins on the various outputs by computer.

2. For 5210~5290MHz:

Directional gain = 0dBi + 10log(2) = 3dBi < 6dBi, so the limit no need to reduced.

For 5530MHz:

Directional gain = 0dBi + 10log(2) = 3dBi < 6dBi, so the limit no need to reduced.

4.5 PEAK POWER EXCURSION MEASUREMENT

4.5.1 LIMITS OF PEAK POWER EXCURSION MEASUREMENT

Shall not exceed 13 dB.

4.5.2 TEST SETUP



4.5.3 TEST INSTRUMENTS

Refer to section 4.1.3 to get information of above instrument.

4.5.4 TEST PROCEDURE

- 1) Set RBW = 1 MHz, VBW \geq 3 MHz, Detector = peak.
- 2) Trace mode = max-hold. Allow the sweeps to continue until the trace stabilizes.
- 3) Use the peak search function to find the peak of the spectrum.
- 4) Measure the PPSD.
- 5) Compute the ratio of the maximum of the peak-max-hold spectrum to the PPSD.

4.5.5 DEVIATION FROM TEST STANDARD

No deviation.

4.5.6 EUT OPERATING CONDITIONS

Same as 4.2.6



A D T

4.5.7 TEST RESULTS

802.11a

CHANNEL	CHANNEL FREQUENCY (MHz)	PEAK VALUE (dBm)	PPSD (dBm)	PEAK EXCURSION (dB)	LIMIT (dB)	PASS/FAIL
36	5180	10.23	3.50	6.73	13	PASS
40	5200	10.23	3.44	6.79	13	PASS
48	5240	10.31	3.54	6.77	13	PASS
52	5260	16.46	9.21	7.25	13	PASS
60	5300	16.36	9.17	7.19	13	PASS
64	5320	12.71	6.11	6.60	13	PASS
100	5500	16.25	9.08	7.17	13	PASS
116	5580	16.35	9.24	7.11	13	PASS
140	5700	16.41	9.15	7.26	13	PASS

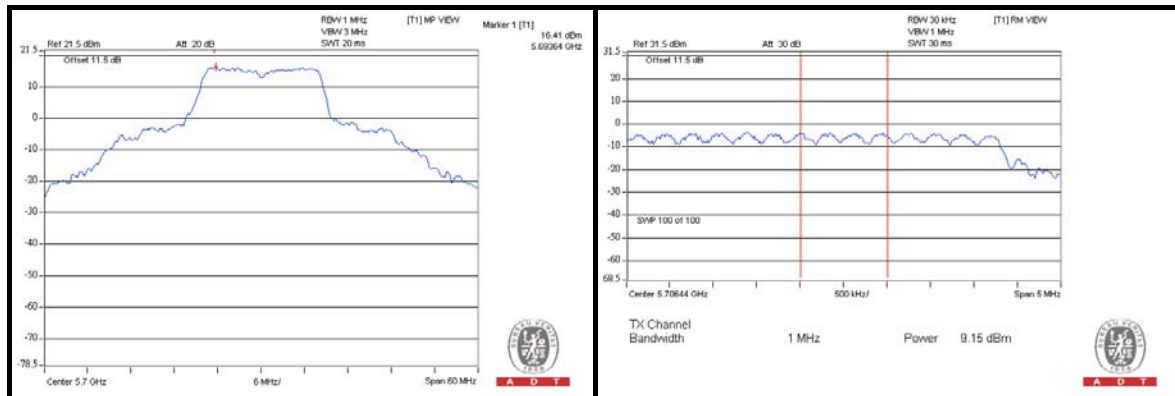



A D T

802.11n (20MHz)

CHAN.	CHAN. FREQ. (MHz)	PEAK VALUE (dBm)		PPSD (dBm)		PEAK EXCURSION (dB)		LIMIT (dB)	PASS/ FAIL
		CHAIN 0	CHAIN 1	CHAIN 0	CHAIN 1	CHAIN 0	CHAIN 1		
36	5180	7.48	8.99	0.24	0.41	7.24	8.58	13	PASS
40	5200	7.84	8.95	0.61	0.51	7.23	8.44	13	PASS
48	5240	7.74	8.84	0.42	0.25	7.32	8.59	13	PASS
52	5260	14.32	15.99	7.07	7.43	7.25	8.56	13	PASS
60	5300	14.28	15.61	7.35	7.18	6.93	8.43	13	PASS
64	5320	14.18	15.83	7.30	7.53	6.88	8.30	13	PASS
100	5500	14.44	15.61	7.50	7.22	6.94	8.39	13	PASS
116	5580	13.86	15.55	7.14	7.29	6.72	8.26	13	PASS
140	5700	14.38	16.06	7.11	7.43	7.27	8.63	13	PASS

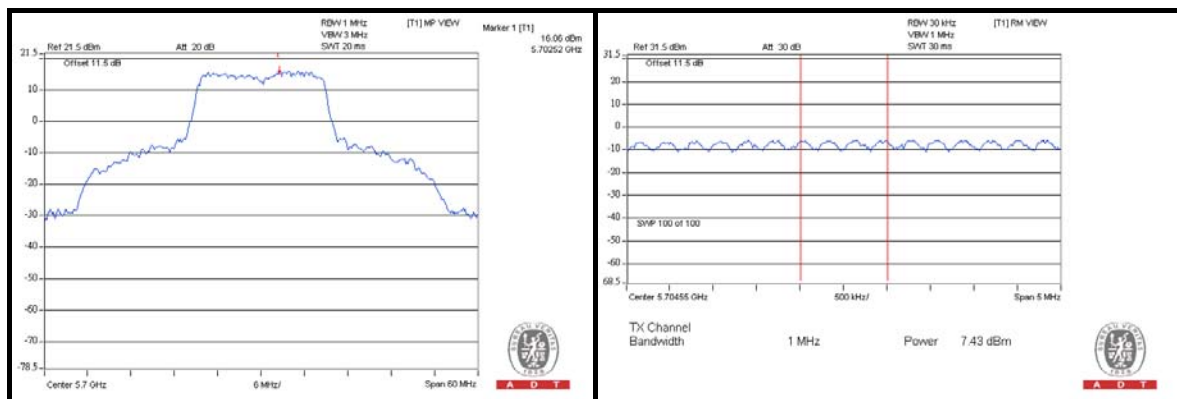



A D T

802.11n (40MHz)

CHAN.	CHAN. FREQ. (MHz)	PEAK VALUE (dBm)		PPSD (dBm)		PEAK EXCURSION (dB)		LIMIT (dB)	PASS/ FAIL
		CHAIN 0	CHAIN 1	CHAIN 0	CHAIN 1	CHAIN 0	CHAIN 1		
38	5190	6.50	5.24	-2.01	-1.81	8.51	7.05	13	PASS
46	5230	6.33	5.78	-1.76	-1.51	8.09	7.29	13	PASS
54	5270	13.03	13.24	5.14	5.95	7.89	7.29	13	PASS
62	5310	8.12	7.66	0.67	0.52	7.45	7.14	13	PASS
102	5510	10.54	9.96	2.93	2.56	7.61	7.40	13	PASS
110	5550	12.82	12.75	5.03	5.67	7.79	7.08	13	PASS
134	5670	11.19	10.78	2.64	2.36	8.55	8.42	13	PASS

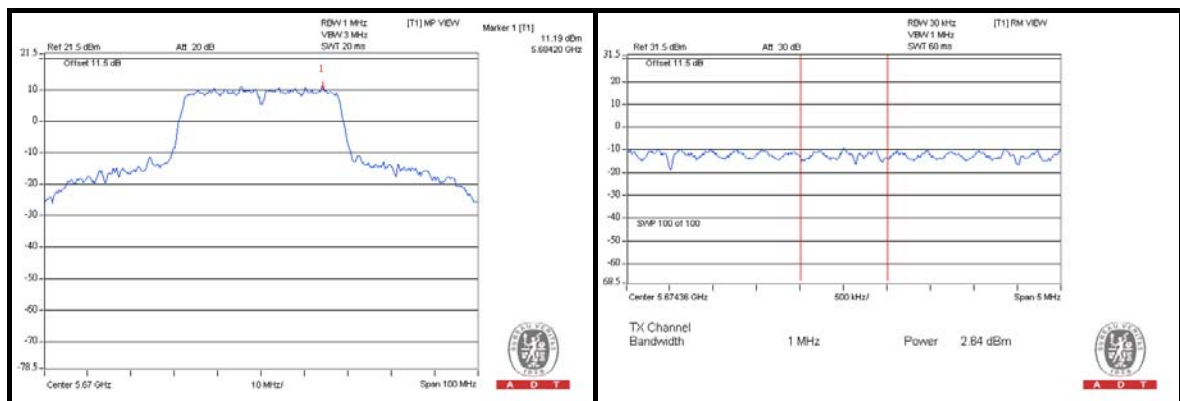



A D T

802.11ac (80MHz)

CHAN.	CHAN. FREQ. (MHz)	PEAK VALUE (dBm)		PPSD (dBm)		PEAK EXCURSION (dB)		LIMIT (dB)	PASS/ FAIL
		CHAIN 0	CHAIN 1	CHAIN 0	CHAIN 1	CHAIN 0	CHAIN 1		
42	5210	5.11	4.52	-3.44	-3.60	8.55	8.12	13	PASS
58	5290	7.57	8.13	-0.70	-0.63	8.27	8.76	13	PASS
106	5530	7.45	5.93	-0.91	-2.42	8.36	8.35	13	PASS

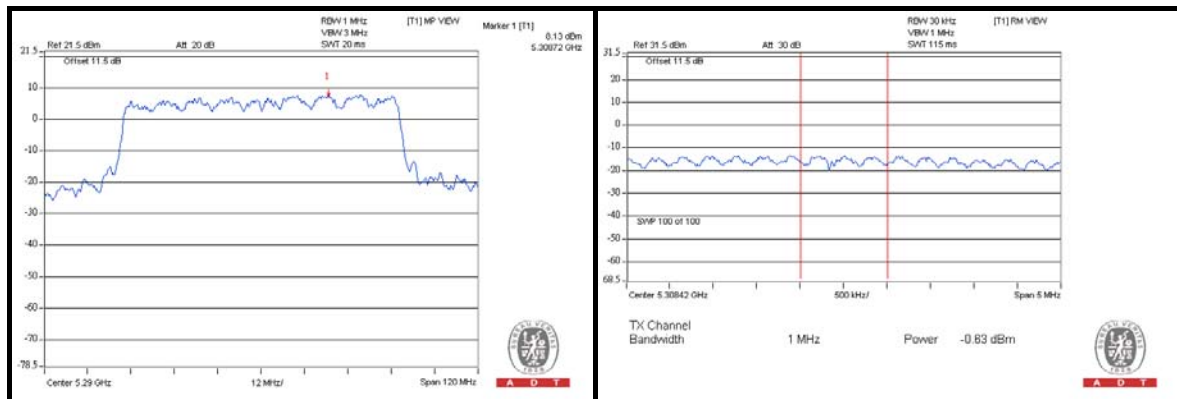

4.6 FREQUENCY STABILITY

4.6.1 LIMITS OF FREQUENCY STABILITY MEASUREMENT

The frequency of the carrier signal shall be maintained within band of operation

4.6.2 TEST SETUP

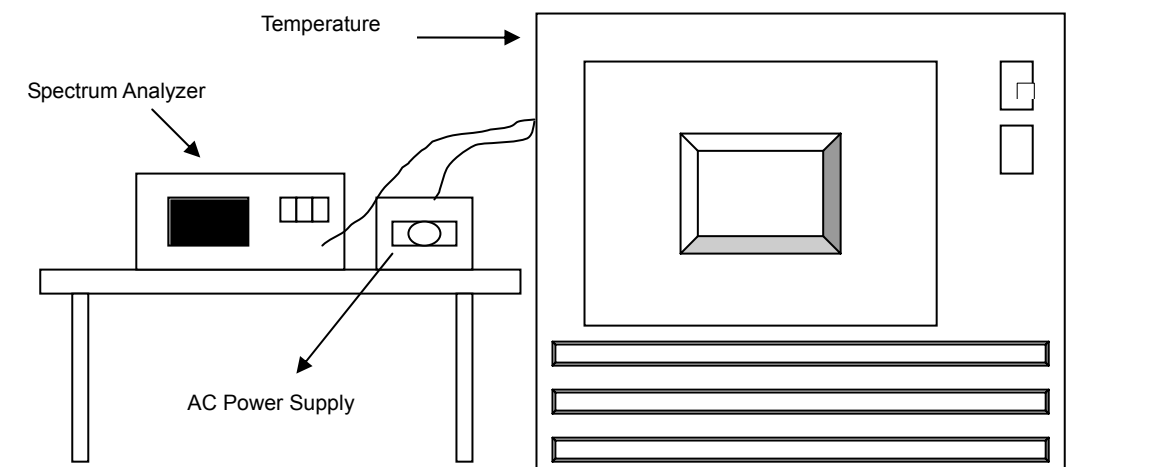

4.6.3 TEST INSTRUMENTS

Refer to section 4.1.3 to get information of above instrument.

4.6.4 TEST PROCEDURE

- a. The EUT was placed inside the environmental test chamber and powered by nominal AC voltage.
- b. Turn the EUT on and couple its output to a spectrum analyzer.
- c. Turn the EUT off and set the chamber to the highest temperature specified.
- d. Allow sufficient time (approximately 30 min) for the temperature of the chamber to stabilize, turn the EUT on and measure the operating frequency after 2, 5, and 10 minutes.
- e. Repeat step 2 and 3 with the temperature chamber set to the lowest temperature.
- f. The test chamber was allowed to stabilize at +20 degree C for a minimum of 30 minutes. The supply voltage was then adjusted on the EUT from 85% to 115% and the frequency record.

4.6.5 DEVIATION FROM TEST STANDARD

No deviation.

4.6.6 EUT OPERATING CONDITION

Set the EUT transmit at un-modulation mode to test frequency stability.

4.6.7 TEST RESULTS

FREQUENCY STABILITY VERSUS TEMP.									
OPERATING FREQUENCY: 5190MHz									
TEMP. (°C)	POWER SUPPLY (Vac)	0 MINUTE		2 MINUTE		5 MINUTE		10 MINUTE	
		Measured Frequency (MHz)	Frequency Drift (ppm)	Measured Frequency (MHz)	Frequency Drift (ppm)	Measured Frequency (MHz)	Frequency Drift (ppm)	Measured Frequency (MHz)	Frequency Drift (ppm)
60	120	5190.0024	0.4624	5190.0008	0.1541	5190.0059	1.1368	5190.0025	0.4817
50	120	5190.0068	1.3102	5189.9992	-0.1541	5189.9984	-0.3083	5190.001	0.1927
40	120	5190.0149	2.8709	5190.019	3.6609	5190.0204	3.9306	5190.0193	3.7187
30	120	5189.9828	-3.3141	5189.9725	-5.2987	5189.9771	-4.4123	5189.9798	-3.8921
20	120	5189.9963	-0.7129	5189.9922	-1.5029	5189.9946	-1.0405	5190.0022	0.4239
10	120	5190.0215	4.1426	5190.0119	2.2929	5190.0209	4.0270	5190.0132	2.5434
0	120	5189.9898	-1.9653	5189.9988	-0.2312	5190.0002	0.0385	5189.9988	-0.2312
-10	120	5190.0136	2.6204	5190.0067	1.2909	5190.0048	0.9249	5190.0049	0.9441
-20	120	5190.0291	5.6069	5190.0262	5.0482	5190.023	4.4316	5190.0292	5.6262
-30	120	5190.015	2.8902	5190.0165	3.1792	5190.0133	2.5626	5190.014	2.6975

FREQUENCY STABILITY VERSUS VOLTAGE									
OPERATING FREQUENCY: 5190MHz									
TEMP. (°C)	POWER SUPPLY (Vac)	0 MINUTE		2 MINUTE		5 MINUTE		10 MINUTE	
		Measured Frequency (MHz)	Frequency Drift (ppm)	Measured Frequency (MHz)	Frequency Drift (ppm)	Measured Frequency (MHz)	Frequency Drift (ppm)	Measured Frequency (MHz)	Frequency Drift (ppm)
20	138	5189.9964	-0.6936	5189.9923	-1.4836	5189.9964	-0.6936	5190.0011	0.2119
	120	5189.9963	-0.7129	5189.9922	-1.5029	5189.9946	-1.0405	5190.0022	0.4239
	102	5189.9954	-0.8863	5189.9915	-1.6378	5189.9966	-0.6551	5190.0007	0.1349

5. PHOTOGRAPHS OF THE TEST CONFIGURATION

Please refer to the attached file (Test Setup Photo).



6. INFORMATION ON THE TESTING LABORATORIES

We, Bureau Veritas Consumer Products Services (H.K.) Ltd., Taoyuan Branch, were founded in 1988 to provide our best service in EMC, Radio, Telecom and Safety consultation. Our laboratories are accredited and approved according to ISO/IEC 17025.

If you have any comments, please feel free to contact us at the following:

Linko EMC/RF Lab:
Tel: 886-2-26052180
Fax: 886-2-26051924

Hsin Chu EMC/RF Lab:
Tel: 886-3-5935343
Fax: 886-3-5935342

Hwa Ya EMC/RF/Safety Telecom Lab:
Tel: 886-3-3183232
Fax: 886-3-3270892

Email: service.adt@tw.bureauveritas.com

Web Site: www.bureauveritas-adt.com

The address and road map of all our labs can be found in our web site also.

7. APPENDIX A – MODIFICATIONS RECORDERS FOR ENGINEERING CHANGES TO THE EUT BY THE LAB

No modifications were made to the EUT by the lab during the test.

---END---