

Test Site:
FCC Test Site No.:
IC OATS No.:

96997
IC3475A-1



ECL-EMC Test Report No.: 11-252

Equipment under test: ION-M7P/7P/85P/19P 1900MHz path
FCC ID: XS5-M778519P
IC ID: 2237E-M778519P
Type of test: **FCC 47 CFR Part 24 Subpart E: 2011**
Broadband PCS
IC RSS-131:2005
Zone Enhancers for the Land Mobile Service

Measurement Procedures: 47 CFR Parts 2: 2011(*Frequency Allocations and Radio Treaty Matters; General Rules and Regulations*), Part 24: 2011 (Personal Communications Services), ANSI/TIA-603-C (2004), *Land Mobile FM or PM Communications Equipment Measurement and Performance Standards*
IC-GEN General Requirements and Information for the Certification of Radiocommunication Equipment

Test result: **Passed**

Date of issue:	20.10.11			Signature:
Issue-No.:	01	Author:	T. Zahlmann Test engineer	
Date of delivery:	17.10.11	Checked:	M. Lehmann Head of the ECL	
Test dates:	12.10. – 18.10.09			
Pages:	45			

Test Report No.: 11-252

FCC ID: XS5-M778519P

IC ID: 2237E-M778519P



Manufacturer: ANDREW Wireless Systems GmbH
Industriering 10

D-86675 Buchdorf

Tel.: +49 (0)9099 69 0

Fax: +49 (0)9099 69 140

Test Location: HERBERG Service Plus GmbH
European Compliance Laboratory (ECL)

Thurn-und Taxis-Straße 18

D-90411 Nürnberg

Tel.: +49 0911 59835 23

Fax: +49 0911 59835 90

General:

The purpose of this report is to show compliance to the FCC regulations for unlicensed devices operating under section 15.249 of the Code of Federal Regulations title 47.

This report informs about the results of the EMC tests, it only refers to the equipment under test. No part of this report may be reproduced in any form, without written permission.



Table of contents

1	TEST RESULTS SUMMARY	5
2	EQUIPMENT UNDER TEST (E.U.T.)	6
2.1	DESCRIPTION	6
2.1.1	DOWNLINK	6
2.1.2	UPLINK	6
2.1.3	DESCRIPTION OF EUT	6
2.1.4	SYSTEM DIAGRAM OF EUT	7
2.1.5	BLOCK DIAGRAM OF MEASUREMENT REFERENCE POINTS	7
3	TEST SITE (ANDREW BUCHDORF)	8
3.1	TEST ENVIRONMENT	8
3.2	TEST EQUIPMENT	8
3.3	INPUT AND OUTPUT LOSSES	8
3.4	MEASUREMENT UNCERTAINTY	8
4	TEST SITE (TEMPTON)	9
5	RF POWER OUT: §24.232, §2.1046	10
5.1	LIMIT	10
5.2	TEST METHOD	10
5.3	TEST RESULTS	11
5.3.1	DOWNLINK	12
5.3.1.1	GSM	13
5.3.1.2	GSM-EDGE	13
5.3.1.3	CDMA	14
5.3.1.4	W-CDMA	14
5.3.1.5	LTE	15
5.3.2	UPLINK	16
5.4	SUMMARY TEST RESULT	16
6	OCCUPIED BANDWIDTH: §2.1049	17
6.1	LIMIT	17
6.2	TEST METHOD	17
6.3	TEST RESULTS	18
6.3.1	DOWNLINK	18
6.3.1.1	GSM	19
6.3.1.2	GSM-EDGE	20
6.3.1.3	CDMA	21
6.3.1.4	W-CDMA	22
6.3.1.5	LTE	23
6.3.2	UPLINK	24
6.4	SUMMARY TEST RESULT	24
7	SPURIOUS EMISSIONS AT ANTENNA TERMINALS: §24.238, §2.1051	25
7.1	LIMIT	25
7.2	TEST METHOD	25



7.3	TEST RESULTS	26
7.3.1	DOWNLINK	26
7.3.1.1	GSM < 1MHz to band edge	28
7.3.1.2	GSM-EDGE < 1MHz to band edge.....	29
7.3.1.3	CDMA < 1MHz to band edge.....	30
7.3.1.4	W-CDMA < 1MHz to band edge	31
7.3.1.5	LTE < 1MHz to band edge.....	32
7.3.1.6	GSM > 1MHz to band edge	33
7.3.1.7	GSM-EDGE > 1MHz to band edge.....	33
7.3.1.8	CDMA > 1MHz to band edge.....	34
7.3.1.9	W-CDMA > 1MHz to band edge	34
7.3.1.10	LTE > 1MHz to band edge.....	35
7.3.2	UPLINK	35
7.4	SUMMARY TEST RESULT	35
8	RADIATED SPURIOUS EMISSIONS: §24.238, §2.1053, RSS-133	36
8.1	LIMIT §24.238.....	39
8.2	TEST METHOD ANSI/TIA/EA-603-C	39
8.3	CLIMATIC VALUES IN THE LAB.....	40
8.4	TEST RESULTS	41
8.4.1	30 MHz TO 1 GHz DOWNLINK (<u>B</u> OTTOM – <u>M</u> IDDLE – <u>T</u> OP)	41
8.4.2	1 GHz -22 GHz DOWNLINK (<u>B</u> OTTOM – <u>M</u> IDDLE – <u>T</u> OP).....	43
8.4.3	HISTORY	45

Test Report No.: 11-252

FCC ID: XS5-M778519P

IC ID: 2237E-M778519P



1 Test Results Summary

Name of Test	FCC Para. No.	FCC Method	FCC Spec.	Result
RF Power Output	24.232(a)	2.1046(a)	1640 W (eirp)	Complies
Occupied Bandwidth		2.1049(h)	Input/Output	Complies
Spurious Emissions at Antenna Terminals	24.238(a)	2.1051	-13dBm	Complies
Field Strength of Spurious Emissions	24.238(a)	2.1053	-13dBm E.I.R.P	Complies
Frequency Stability		2.1055(a)(d)	Must stay in band	NA

Frequency stability is given by: The system gets an electrical analog signal from the BSS which is converted into an analog optical signal, transmitted by the optical links and then reconverted in the Remote Unit into an analog electrical signal. During this process happens no frequency change/modification, so input and output have same frequency what can be seen under capture "Occupied Bandwidth".



2 Equipment under test (E.U.T.)

2.1 Description

Kind of equipment	ION-M7P/7P/85P/19P	
Andrew Ident. Number	7631019-0001	
Serial no.(SN)	11	
Revision	00	
Software version and ID	n. a.	
Type of modulation and Designator	GSM (GXW)	<input checked="" type="checkbox"/>
	GSM-EDGE (G7W)	<input checked="" type="checkbox"/>
	CDMA (F9W)	<input checked="" type="checkbox"/>
	W-CDMA (F9W)	<input checked="" type="checkbox"/>
	LTE (G7D)	<input checked="" type="checkbox"/>
Frequency Translation	F1-F1	<input checked="" type="checkbox"/>
	F1-F2	<input type="checkbox"/>
	N/A	<input type="checkbox"/>
Band Selection	Software	<input type="checkbox"/>
	Duplexer	<input checked="" type="checkbox"/>
	Fullband	<input type="checkbox"/>

2.1.1 Downlink

Pass band	1930 MHz – 1995 MHz
Max. composite output power based on one carrier (rated)	43 dBm = 20 W
System Gain*	10 dB @ Pout BTS of 33 dBm

*see 2.1.5

2.1.2 Uplink

Pass band	1850 MHz – 1915 MHz
System Gain*	n.a.

*see 2.1.5

Note: The EUT does not transmit over the air in the uplink direction.

2.1.3 Description of EUT

ION-M7P/7P/85P/19P is a LTE MIMO, 850 MHz, and 1900 MHz CDMA/WCDMA multi-operator Remote Unit with various Extension Units. It is used in conjunction with a Master Unit in the ION optical distribution system. This system transports multiple LTE channels, a 850 MHz, and a 1900 MHz wideband signal simultaneously, providing a cost-effective solution for distributing capacity from one or more base stations.

The ION-M7P/7P/85P/19P consists of two identical 700 MHz paths with one antenna port each. This Test Report describes only the approval of one path in the range 728 MHz – 757 MHz. Each path covers Cellular 700, with the intended use of simultaneous transmission.

2.1.4 System diagram of EUT

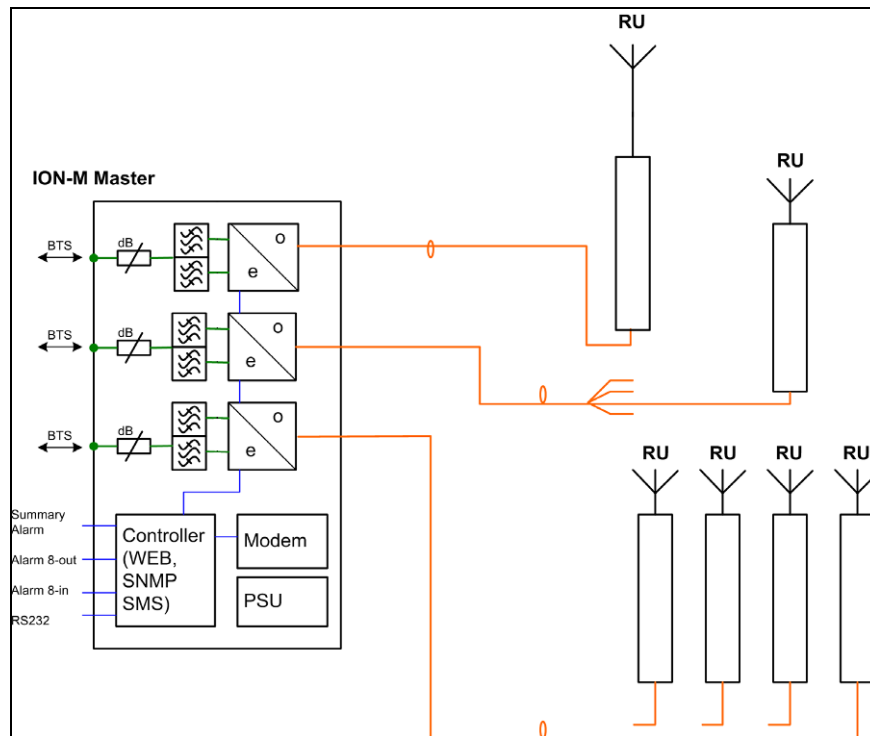

figure 2.1.4-#1 System diagram of EUT: EUT is Remote Unit (RU)

2.1.5 Block diagram of measurement reference points

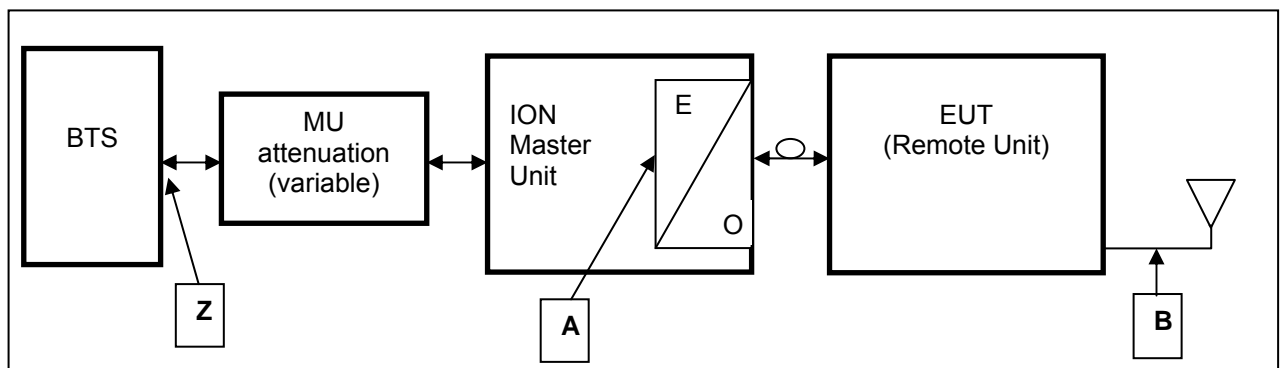

figure 2.1.5-#1 Block diagram of measurement reference points

Remote Unit is the EUT
 O/E Optitcal/Electrical converter
 SRMU SubRack Master Unit

Reference point A, SRMU UL output, DL input
 Reference point B, Remote Unit DL output, UL input
 Reference point Z, BTS DL output, BTS UL input

Since a signal generator does not supply a good output signal with +33 or +43dBm, for the downlink measurement the MU Attenuation is not used. That means for downlink measurements the signal generator is connected to measurement point A at the master optical / electrical converter and the analyzer to the measurement point B at the RU.



3 Test site (Andrew Buchdorf)

3.1 Test environment

All tests were performed under the following environmental conditions:

Condition	Minimum value	Maximum value
Barometric pressure	86 kPa	106 kPa
Temperature	15°C	30°C
Relative Humidity	20 %	75 %
Power supply range	±5% of rated voltages	

3.2 Test equipment

ANDREW Inv. No.	Test equipment	Type	Manufacturer	Serial No.	Calibration
8372	Network Analyzer	8753D	HP	3410A08675	02/12
8890	Spectrum Analyzer	FSP	R&S	100674	08/12
8736	Spectrum Analyzer	FSIQ-26	R&S	100290	12/11
9069	Signal Generator	SMBV100A	R&S	256275	08/12
7412	Power Attenuator	769-30	Narda	09741	CIU
7416	Divider	2way	Andrew	4943	CIU
7414	RF-Cable	1,0m; N-N	Andrew	---	CIU
7415	RF-Cable	2,0m; N-N	Andrew	---	CIU
7418	RF-Cable	0,6m; SMA	Huber & Suhner	---	CIU
7419	RF-Cable	0,6m; SMA	Huber & Suhner	---	CIU
7417	RF-Cable	1,0m; SMA	Huber & Suhner	---	CIU
7413	RF-Cable	1,0m; SMA	Huber & Suhner	---	CIU

CIU = Calibrate in use

3.3 Input and output losses

All recorded power levels should be referenced to the input and output connectors of the repeater, unless explicitly stated otherwise.

The test equipment used in this test has to be calibrated, so that the functionality is also checked.

All cables, attenuators, splitter, isolator, circulator and combiner etc. must be measured before testing and used for compensation during testing.

3.4 Measurement uncertainty

The extended measurement uncertainty corresponds to the measurement results from the standard measurement uncertainty multiplied by the coverage factor $k=2$. The true value is located in the corresponding interval with a probability of 95 %.

Test Report No.: 11-252

FCC ID: XS5-M778519P

IC ID: 2237E-M778519P



4 Test site (TEMPTON)

FCC Test site:

IC OATS:

See relevant dates under section 8.



5 RF Power Out: §24.232, §2.1046

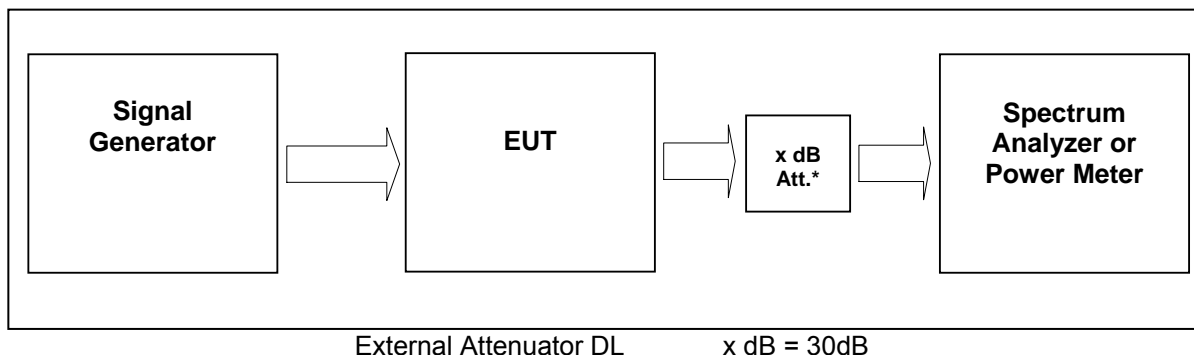

figure 3.4-#1 Test setup: RF Power Out: §24.232, §2.1046

Measurement uncertainty	± 0,38 dB
Test equipment used	8372, 8890, 8736, 9069, 7412, 7416, 7414, 7415, 7418, 7419, 7417, 7413

5.1 Limit

Minimum standard:

Para. No.24.232

(a)(1) Base stations with an emission bandwidth of 1 MHz or less are limited to 1640 watts equivalent isotropically radiated power (EIRP) with an antenna height up to 300 meters HAAT, except as described in paragraph (b) below.

(2) Base stations with an emission bandwidth greater than 1 MHz are limited to 1640 watts/MHz equivalent isotropically radiated power (EIRP) with an antenna height up to 300 meters HAAT, except as described in paragraph (b) below.

Table 1—Reduced Power for Base Station Antenna Heights Over 300 Meters

HAAT in meters	Maximum EIRP watts
≤ 300	1640
≤ 500	1070
≤ 1000	490
≤ 1500	270
≤ 2000	160

5.2 Test method

§ 2.1046 Measurements required: RF power output.

(a) For transmitters other than single sideband, independent sideband and controlled carrier radiotelephone, power output shall be measured at the RF output terminals when the transmitter is adjusted in accordance with the tune-up procedure to give the values of current and voltage on the circuit elements specified in § 2.1033(c)(8). The electrical characteristics of the radio frequency load attached to the output terminals when this test is made shall be stated.

Test Report No.: 11-252

FCC ID: XS5-M778519P

IC ID: 2237E-M778519P



(c) For measurements conducted pursuant to paragraphs (a) and (b) of this section, all calculations and methods used by the applicant for determining carrier power or peak envelope power, as appropriate, on the basis of measured power in the radio frequency load attached to the transmitter output terminals shall be shown. Under the test conditions specified, no components of the emission spectrum shall exceed the limits specified in the applicable rule parts as necessary for meeting occupied bandwidth or emission limitations

5.3 Test results

Detector RMS.

Test signal GSM:

Signal waveform with GMSK modulation in all time slots according to 3GPP TS45.004

Test signal GSM EDGE:

Signal waveform with 8-PSK modulation in all time slots according to 3GPP TS45.004

Test signal CDMA

Signal waveform according to table 6.2-1 of standard specification 3GPP2 C.p0051-0 v1.0 16.February 2006 pilot, sync, paging, 37 traffics, which is equal to the table 6.5.2.1 of 3GPP2 C.S0010-C v2.0 24.February 2006.

Test signal WCDMA

Signal waveform according to Test Model 1 of standard specification 3GPP TS25.141. Signal modulated with a combination of PCCPCH, SCCPCH and Dedicated Physical Channels specified as test model 1 64 DPCH.

Test signal LTE:

Signal waveform according to Test Model 1.1, E-TM1.1, clause 6.1.1.1-1, table 6.1.1.1-1 of standard specification 3GPP TS 36.141 V9.3.0 (2010-03).



5.3.1 Downlink

Modulation	Measured at	RBW VBW Span	RF Power (dBm)	RF Power (W)	Plot -
GSM	1962,5MHz	1MHz 3MHz 10MHz	42.9	19,5	5.3.1.1 #1
GSM-EDGE	1962,5 MHz	1MHz 3MHz 10MHz	43.0	20	5.3.1.2 #1
CDMA	1962,5 MHz	3MHz 10MHz 15MHz	43.0	20	5.3.1.3 #1
WCDMA	1962,5 MHz	10MHz 10MHz 50MHz	43.0	20	5.3.1.4 #1
LTE	1962,5 MHz	3MHz 10MHz 15MHz	43.0	20	5.3.1.5 #1
Maximum output power = 43.0 dBm = 20 W					
Limit Maximum output power = 1640 W -> 62,15 dBm					

table 5.3.1-#1 RF Power Out: §24.232, §2.1046 Test results Downlink

The max RF Power out is 43.0 dBm, so the maximum antenna gain (x) can be calculated as follow:

Limit = 1630W (eirp) = 62.15 dBm

Info: 1000W (erp) = 1640W (eirp)

60 dBm > 43 dBm + x

19.15 dBi > x

=> The antenna that will use for the complete system have to have a gain lower than 19 dBi, relative to a dipole antenna.

Modulation	Pin / dBm (Ref. point B)
GSM	7.0
EDGE	7.1
CDMA	7.1
WCDMA	7.8
LTE	7.4

table 5.3.1-#2 RF Power Out: §24.232, §2.1046 Test results Downlink Input power



5.3.1.1 GSM

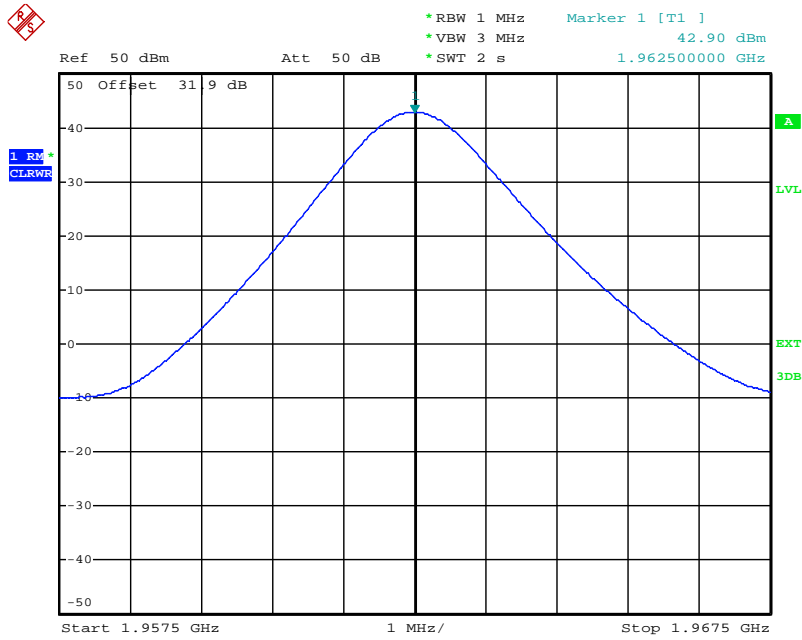

Date: 12.OCT.2011 09:58:40

plot 5.3.1.1-#1 RF Power Out: §24.232, §2.1046; Test results; Downlink; GSM Middle

5.3.1.2 GSM-EDGE

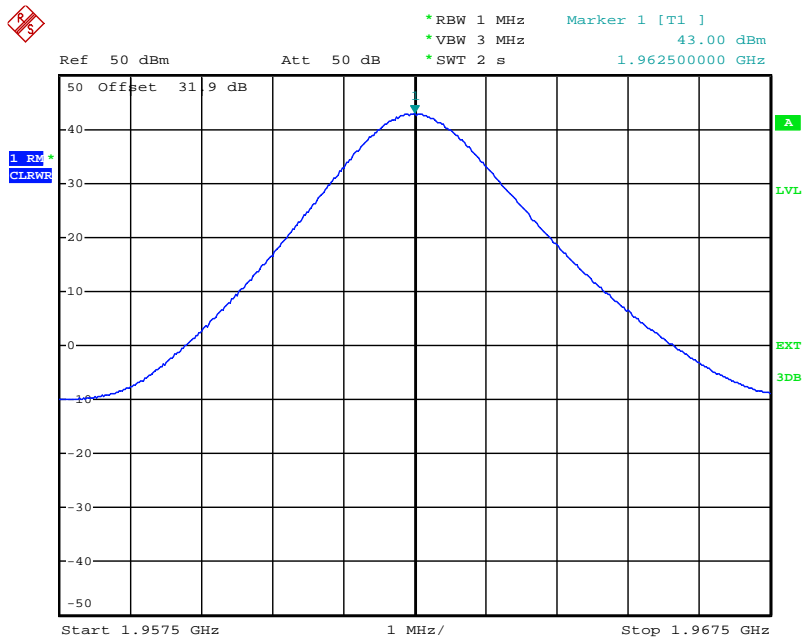

Date: 12.OCT.2011 09:46:40

plot 5.3.1.2-#1 RF Power Out: §24.232, §2.1046; Test results; Downlink; GSM-EDGE Middle



5.3.1.3 CDMA

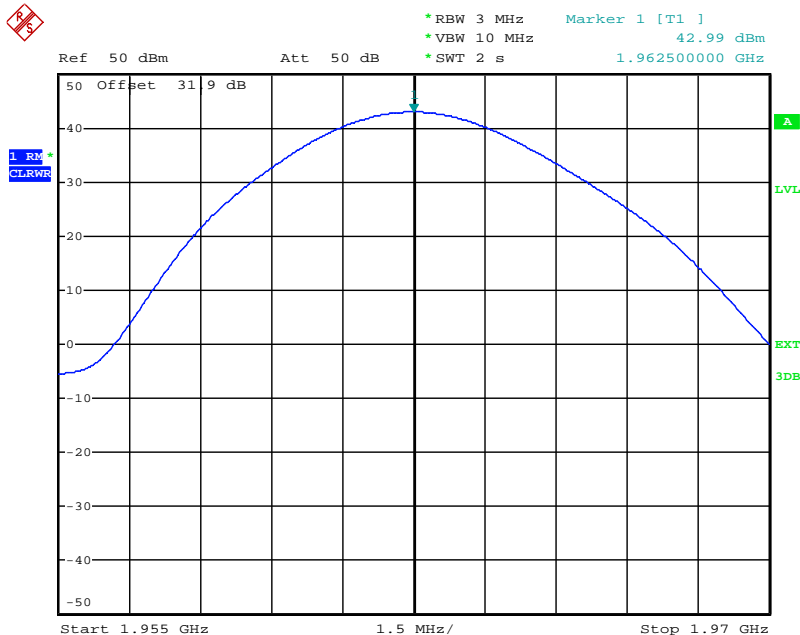

Date: 12.OCT.2011 10:36:37

plot 5.3.1.3-#1 RF Power Out: §24.232, §2.1046; Test results; Downlink; CDMA Middle

5.3.1.4 W-CDMA

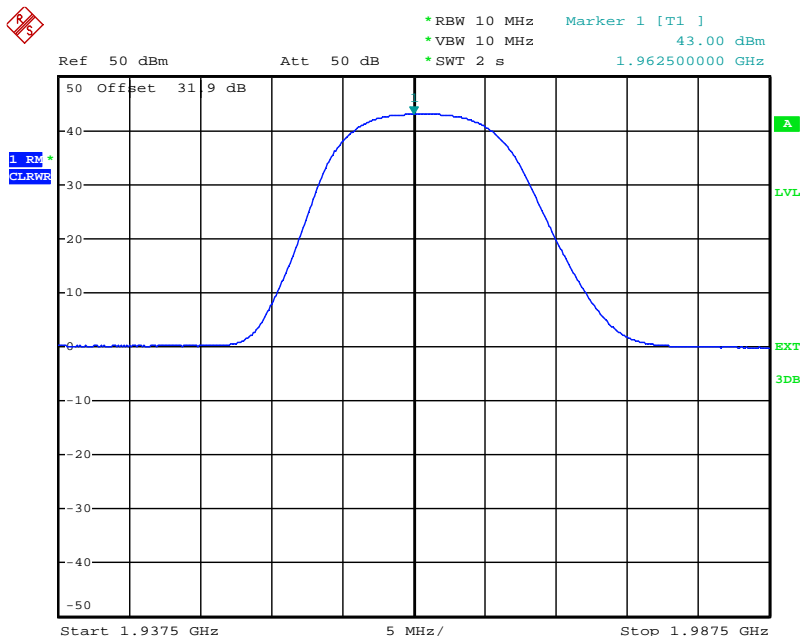

Date: 12.OCT.2011 10:34:17

plot 5.3.1.4-#1 RF Power Out: §24.232, §2.1046; Test results; Downlink; W-CDMA Middle

Test Report No.: 11-252

FCC ID: XS5-M778519P

IC ID: 2237E-M778519P



5.3.1.5 LTE

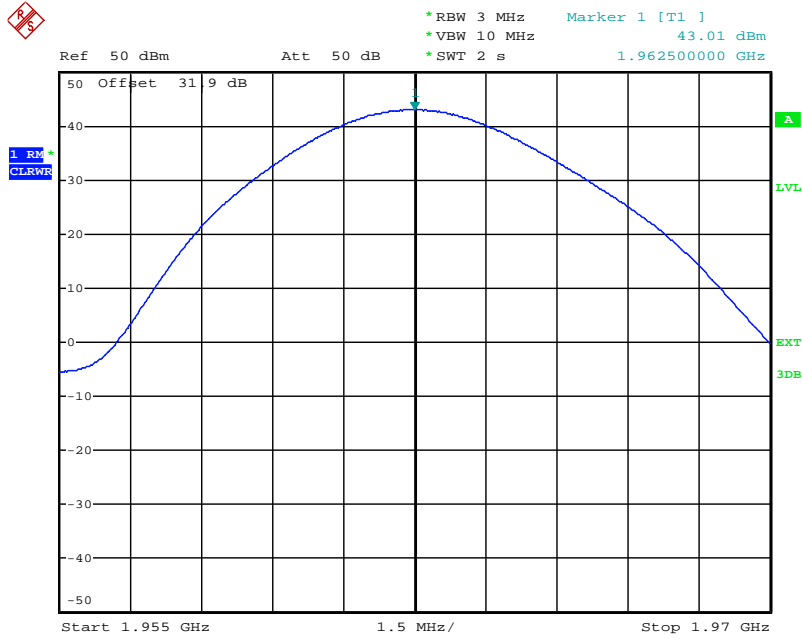

Date: 12.OCT.2011 10:42:02

plot 5.3.1.5-#1 RF Power Out: §24.232, §2.1046; Test results; Downlink; LTE Middle

Test Report No.: 11-252

FCC ID: XS5-M778519P

IC ID: 2237E-M778519P



5.3.2 Uplink

n.a.

Note: The EUT does not transmit over the air in the uplink direction.

5.4 Summary test result

Test result	complies, according the plots above
Tested by:	Ph. Wagner
Date:	12.10.2011

6 Occupied Bandwidth: §2.1049

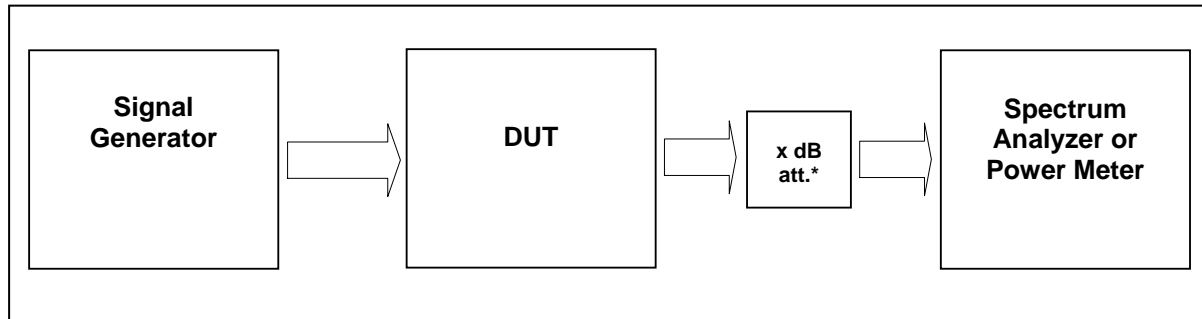

External Attenuator DL x dB = 30 dB
figure 5.4-#1 Test setup: Occupied Bandwidth: §2.1049

Measurement uncertainty	± 0,38 dB
Test equipment used	8372, 8890, 8736, 9069, 7412, 7416, 7414, 7415, 7418, 7419, 7417, 7413

6.1 Limit

The spectral shape of the output should look similar to input for all modulations.

6.2 Test method

Para. No.2.1049

The occupied bandwidth, that is the frequency bandwidth such that, below its lower and above its upper frequency limits, the mean powers radiated are each equal to 0.5 percent of the total mean power radiated by a given emission shall be measured under the following conditions as applicable:

(h) Transmitters employing digital modulation techniques—when modulated by an input signal such that its amplitude and symbol rate represent the maximum rated conditions under which the equipment will be operated. The signal shall be applied through any filter networks, pseudo-random generators or other devices required in normal service. Additionally, the occupied bandwidth shall be shown for operation with any devices used for modifying the spectrum when such devices are optional at the discretion of the user.



6.3 Test results

6.3.1 Downlink

Detector RMS.

Modulation	Measured at	Carrier /MHz	RBW VBW Span	Occupied Bandwidth / MHz	Plot #
GSM	Middle	1962,5MHz	3kHz 30kHz 1MHz	0.246	6.3.1.1 #1, #2
GSM-EDGE	Middle	1962,5 MHz	3kHz 30kHz 1MHz	0.244	6.3.1.2 #1, #2
CDMA	Middle	1962,5 MHz	30kHz 300kHz 5MHz	1.24	6.3.1.3 #1, #2
WCDMA	Middle	1962,5 MHz	100kHz 1MHz 10MHz	4.2	6.3.1.4 #1, #2
LTE	Middle	1962,5 MHz	30 kHz 300 kHz 5 MHz	1.1	6.3.1.5 #1,#2

table 6.3-#1 Occupied Bandwidth: §2.1049 Test results Downlink



6.3.1.1 GSM

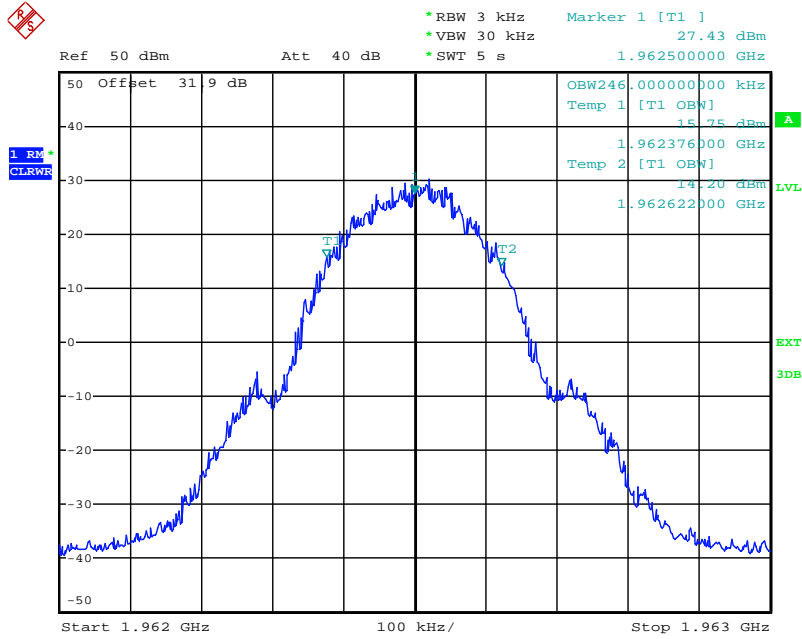

Date: 12.OCT.2011 11:29:01

plot 6.3.1.1-#1 Occupied Bandwidth: §2.1049; Test results; Downlink; GSM Output

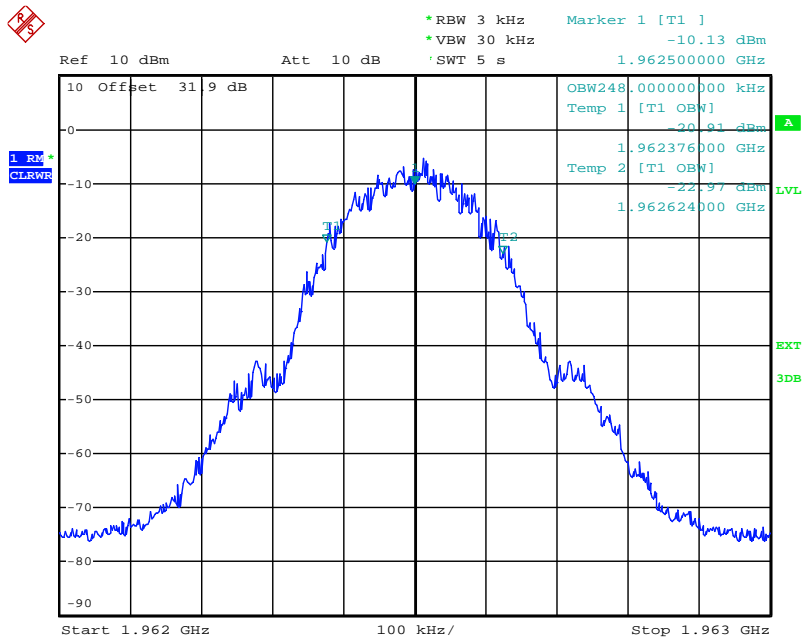

Date: 12.OCT.2011 11:36:11

plot 6.3.1.1-#2 Occupied Bandwidth: §2.1049; Test results; Downlink; GSM Input



6.3.1.2 GSM-EDGE

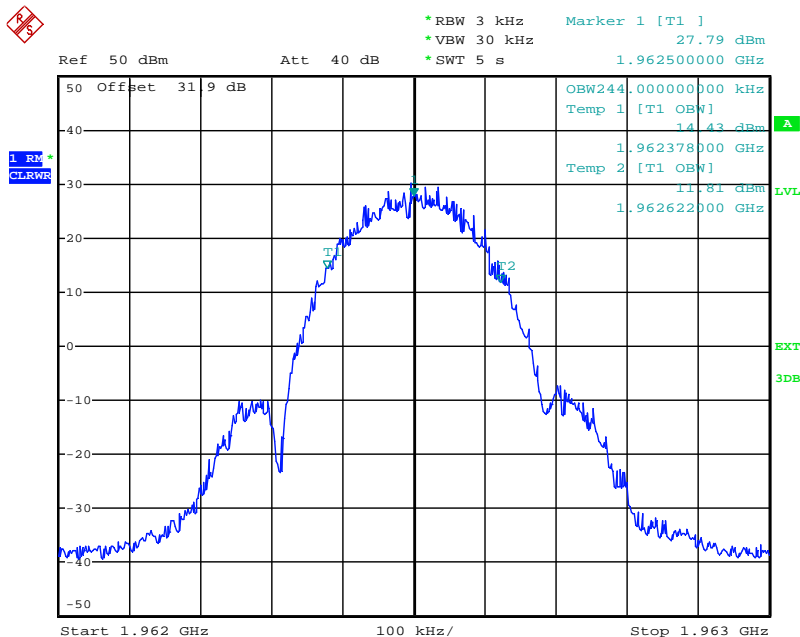

Date: 12.OCT.2011 11:45:17

plot 6.3.1.2-#1 Occupied Bandwidth: §2.1049; Test results; Downlink; GSM-EDGE Output

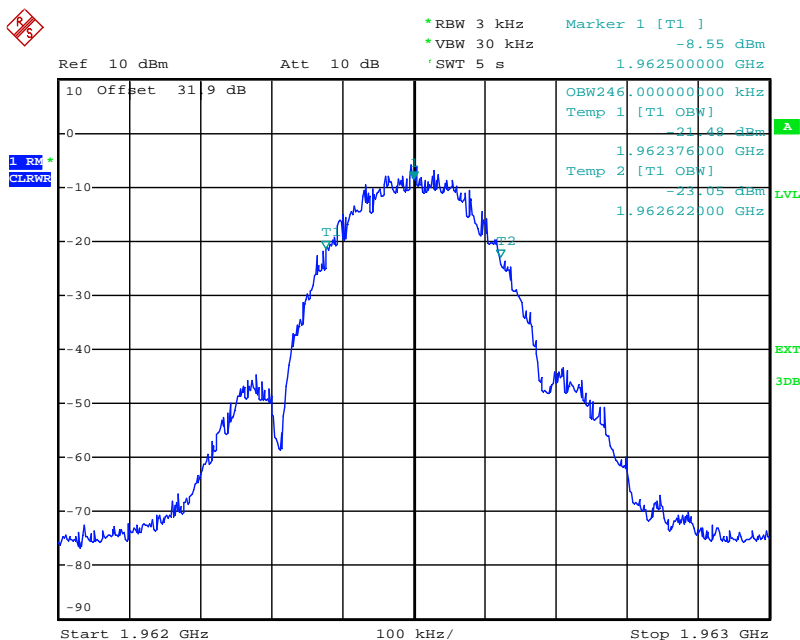

Date: 12.OCT.2011 12:39:09

plot 6.3.1.2-#2 Occupied Bandwidth: §2.1049; Test results; Downlink; GSM-EDGE Input



6.3.1.3 CDMA

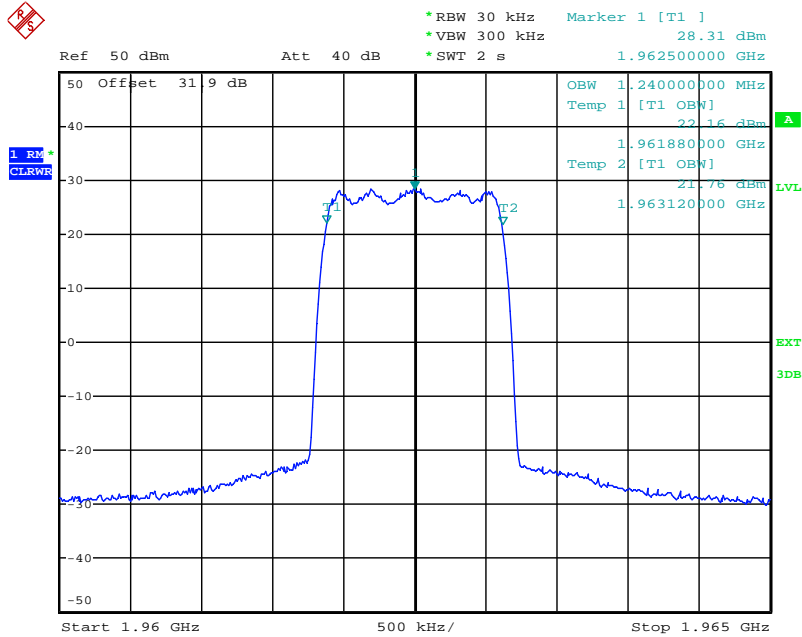

Date: 12.OCT.2011 12:56:08

plot 6.3.1.3-#1 Occupied Bandwidth: §2.1049; Test results; Downlink; CDMA Output

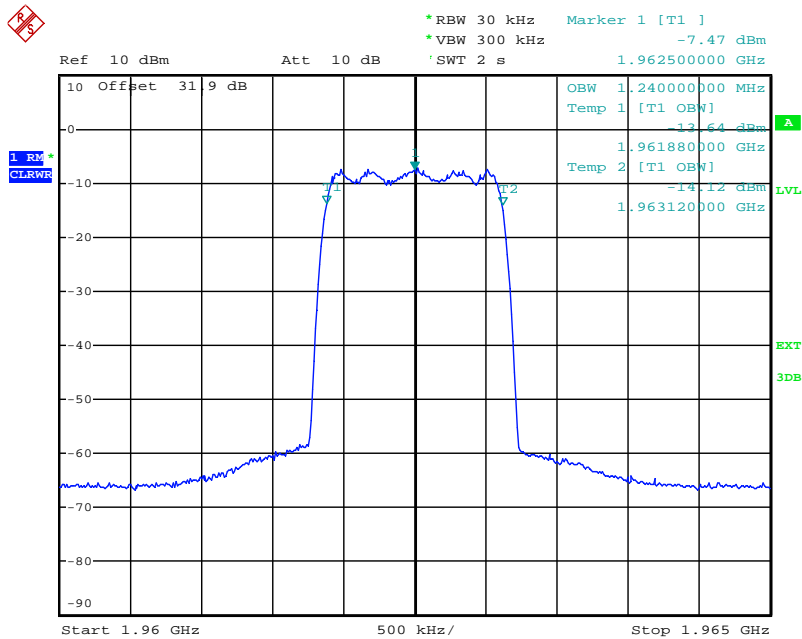

Date: 12.OCT.2011 13:07:48

plot 6.3.1.3-#2 Occupied Bandwidth: §2.1049; Test results; Downlink; CDMA Input



6.3.1.4 W-CDMA

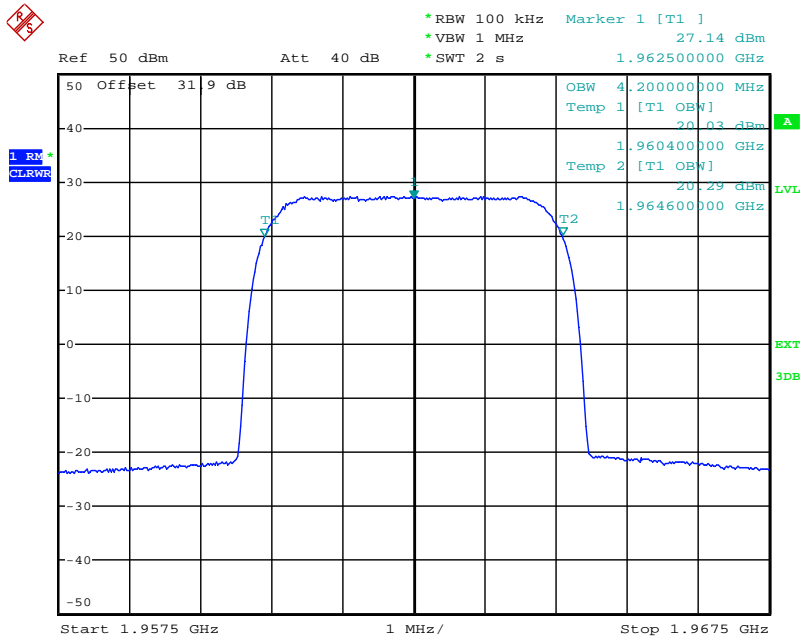

Date: 12.OCT.2011 13:14:41

plot 6.3.1.4-#1 Occupied Bandwidth: \$2.1049; Test results; Downlink; W-CDMA Output

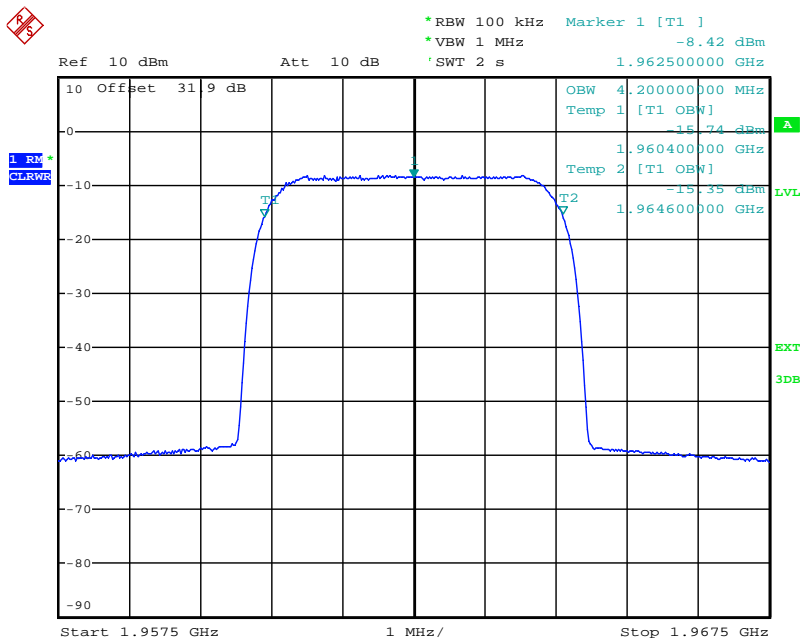

Date: 12.OCT.2011 13:17:08

plot 6.3.1.4-#2 Occupied Bandwidth: \$2.1049; Test results; Downlink; W-CDMA Input



6.3.1.5 LTE

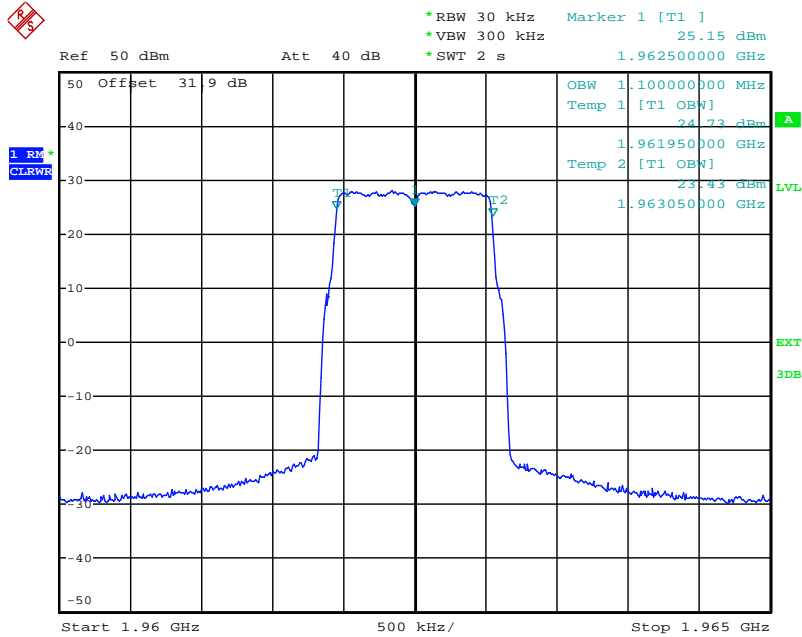

Date: 12.OCT.2011 13:20:39

plot 6.3.1.5-#1 Occupied Bandwidth: \$2.1049; Test results; Downlink; LTE Output

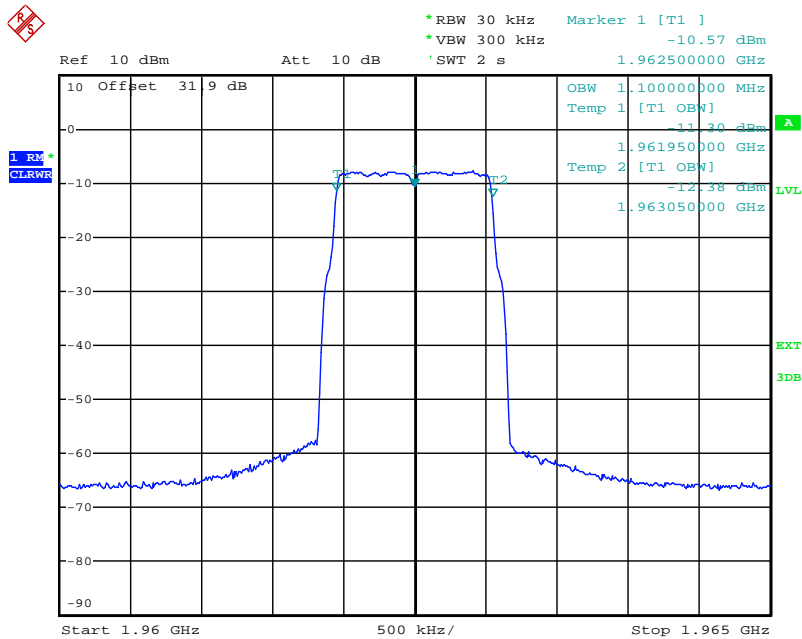

Date: 12.OCT.2011 13:24:21

plot 6.3.1.5-#2 Occupied Bandwidth: \$2.1049; Test results; Downlink; LTE Input

Test Report No.: 11-252

FCC ID: XS5-M778519P

IC ID: 2237E-M778519P



6.3.2 Uplink

n.a.

Note: The EUT does not transmit over the air in the uplink direction.

6.4 Summary test result

Test result	complies, according the plots above
Tested by:	Ph. Wagner
Date:	12.10.2011



7 Spurious Emissions at Antenna Terminals: §24.238, §2.1051

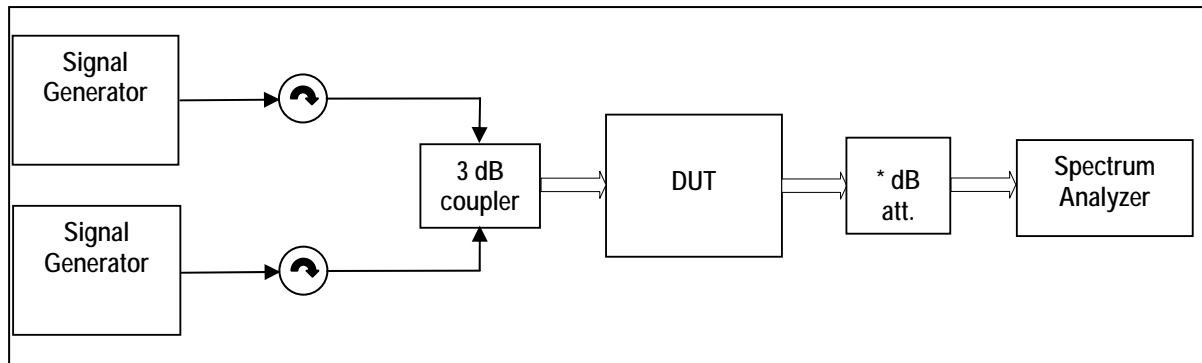

Multisignal-Generator used, External Attenuator DL x dB = 30 dB
 figure 7-#1 Test setup: Spurious Emissions at Antenna Terminals: §24.238, §2.1051

Measurement uncertainty	± 0,54 dB ± 1,2 dB ± 1,5 dB	9 kHz to 3 GHz 3 GHz to 7 GHz 7 GHz to 26 GHz
Test equipment used	8372, 8890, 8736, 9069, 7412, 7416, 7414, 7415, 7418, 7419, 7417, 7413	

7.1 Limit

Minimum standard:

Para. No.24.238(a)

The rules in this section govern the spectral characteristics of emissions in the Broadband Personal Communications Service.

(a) Out of band emissions. The power of any emission outside of the authorized operating frequency ranges must be attenuated below the transmitting power (P) by a factor of at least $43 + 10 \log(P)$ dB.

7.2 Test method

Para. No 2.1051 Measurements required: Spurious emissions at antenna terminals.

The radio frequency voltage or powers generated within the equipment and appearing on a spurious frequency shall be checked at the equipment output terminals when properly loaded with a suitable artificial antenna. Curves or equivalent data shall show the magnitude of each harmonic and other spurious emission that can be detected when the equipment is operated under the conditions specified in § 2.1049 as appropriate. The magnitude of spurious emissions which are attenuated more than 20 dB below the permissible value need not be specified.

[39 FR 5919, Feb. 15, 1974. Redesignated and amended at 63 FR 36599, July 7, 1998]



7.3 Test results

7.3.1 Downlink

<1MHz from Band Edge

Detector: RMS.

Modulation	Measured at Band Edge	Carriers	RBW VBW Span	Max. level (dBm)	Plot -
GSM	Lower Edge Upper Edge	1930,4 MHz 1930,6 MHz 1994,4 MHz 1994,6 MHz	3kHz 30kHz 2MHz	-28.94	7.3.1.1 #1 #2
GSM-EDGE	Lower Edge Upper Edge	1930,4 MHz 1930,6 MHz 1994,4 MHz 1994,6 MHz	3kHz 30kHz 2MHz	-31.83	7.3.1.2 #1 #2
CDMA	Lower Edge Upper Edge	1930,775 MHz 1932,025 MHz 1992,975 MHz 1994,225 MHz	30kHz 300kHz 6MHz	-13.40	7.3.1.3 #1 #2
WCDMA	Lower Edge Upper Edge	1932,6 MHz 1937,6 MHz 1987,4 MHz 1992,4 MHz	100kHz 1MHz 15MHz	-19.11	7.3.1.4 #1 #2
LTE	Lower Edge Upper Edge	1930,7 MHz 1932,1 MHz 1994,3 MHz 1992,9 MHz	30kHz 300kHz 6MHz	-21.22	7.3.1.5 #1 #2

table 7.3-#1 Spurious Emissions at Antenna Terminals: §24.238, §2.1051 Test results Downlink <1MHz from Band Edge



>1MHz from Band Edge
 Detector: RMS.

Modulation	Carrier at	Carrier	Max. level (dBm)	RBW VBW Frequency range	Plot -
GSM	Middle	1962,5 MHz	-16.31	1MHz 3MHz 30MHz – 20GHz	7.3.1.6 #1
GSM-EDGE	Middle	1962,5 MHz	-16.31	1MHz 3MHz 30MHz – 20GHz	7.3.1.7 #1
CDMA	Middle	1962,5 MHz	-16.31	1MHz 3MHz 30MHz – 20GHz	7.3.1.8 #1
WCDMA	Middle	1962,5 MHz	-16.31	1MHz 3MHz 30MHz – 20GHz	7.3.1.9 #1
LTE	Middle	1962,5 MHz	-16.31	1MHz 3MHz 30MHz – 20GHz	7.3.1.10 #1

table 7.3-#2 Spurious Emissions at Antenna Terminals: §24.238, §2.1051 Test results Downlink >1MHz from Band Edge



7.3.1.1 GSM < 1MHz to band edge

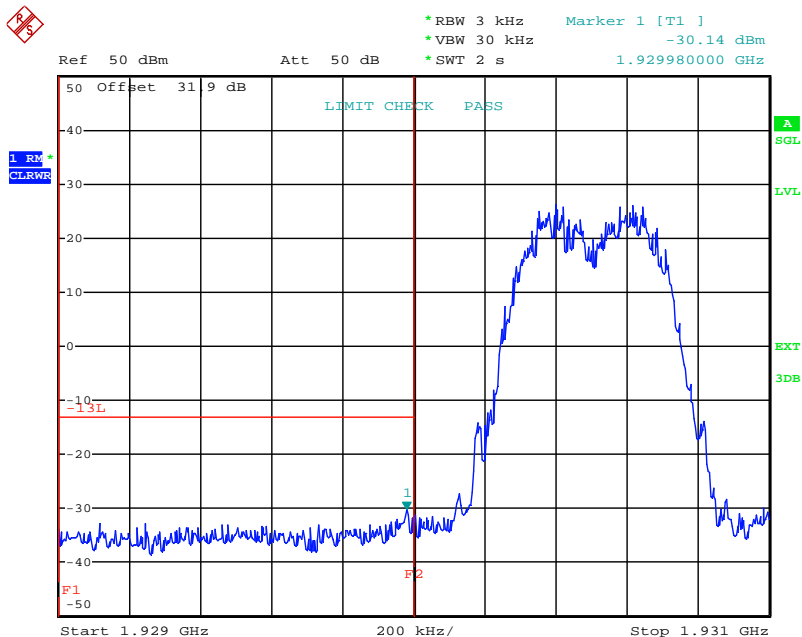

Date: 12.OCT.2011 14:30:41

plot 7.3.1.1-#1 Spurious Emissions at Antenna Terminals: §24.238, §2.1051; Test results; Downlink; GSM < 1MHz to band edge Lower Band Edge

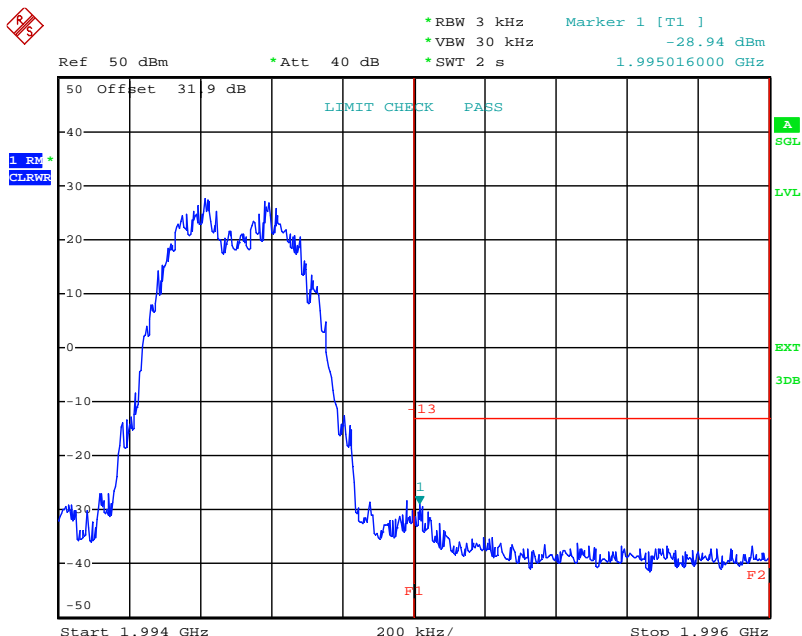

Date: 12.OCT.2011 16:38:13

plot 7.3.1.1-#2 Spurious Emissions at Antenna Terminals: §24.238, §2.1051; Test results; Downlink; GSM < 1MHz to band edge Upper Band Edge



7.3.1.2 GSM-EDGE < 1MHz to band edge

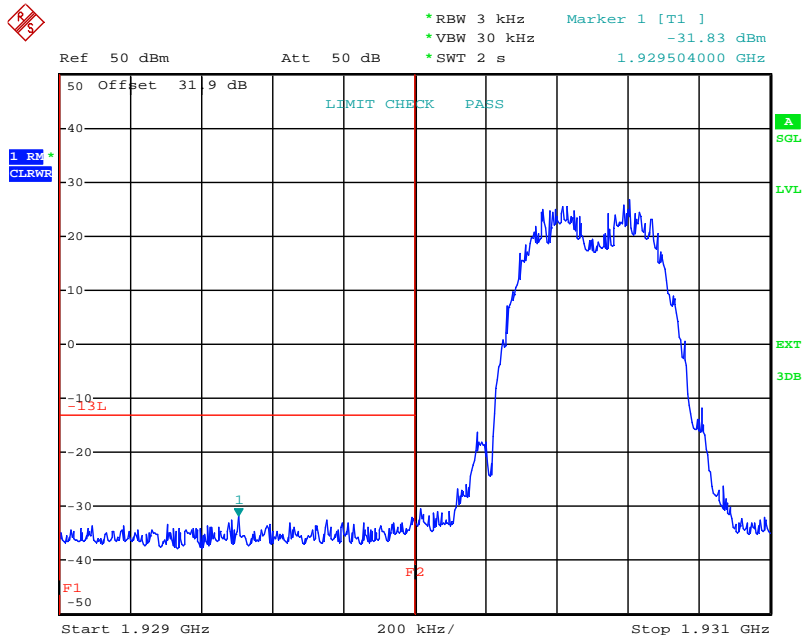

Date: 12.OCT.2011 14:58:51

plot 7.3.1.2-#1 Spurious Emissions at Antenna Terminals: §24.238, §2.1051; Test results; Downlink; GSM-EDGE < 1MHz to band edge Lower Band Edge

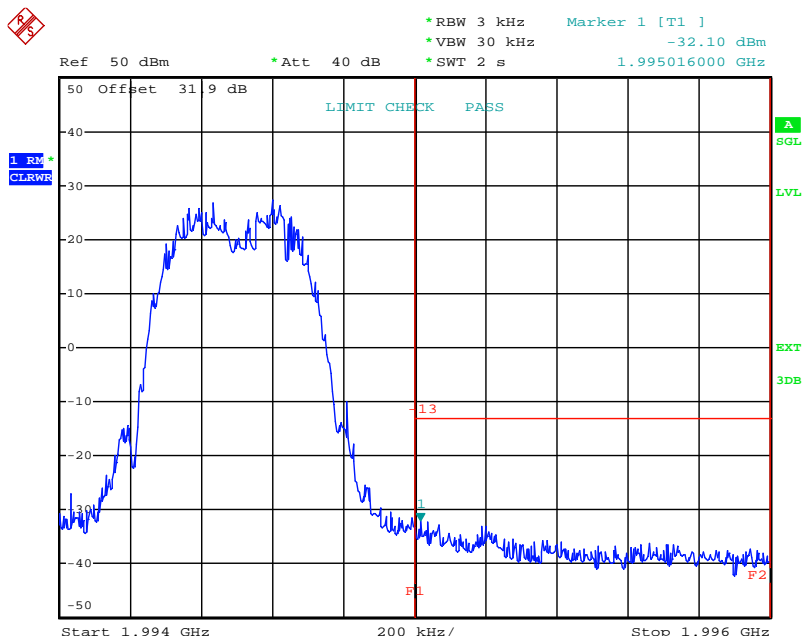

Date: 12.OCT.2011 16:36:00

plot 7.3.1.2-#2 Spurious Emissions at Antenna Terminals: §24.238, §2.1051; Test results; Downlink; GSM-EDGE < 1MHz to band edge Upper Band Edge



7.3.1.3 CDMA < 1MHz to band edge

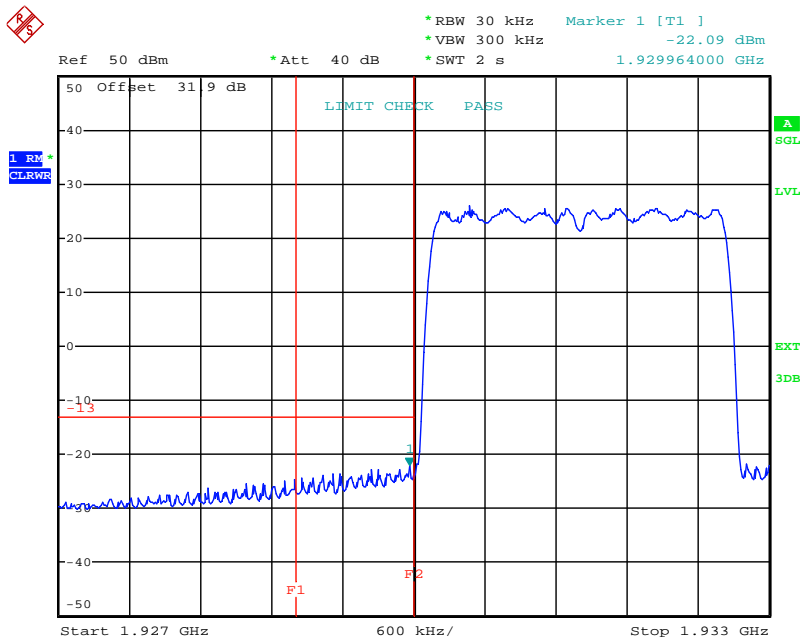

Date: 12.OCT.2011 15:50:37

plot 7.3.1.3-#1 Spurious Emissions at Antenna Terminals: §24.238, §2.1051; Test results; Downlink; CDMA < 1MHz to band edge Lower Band Edge

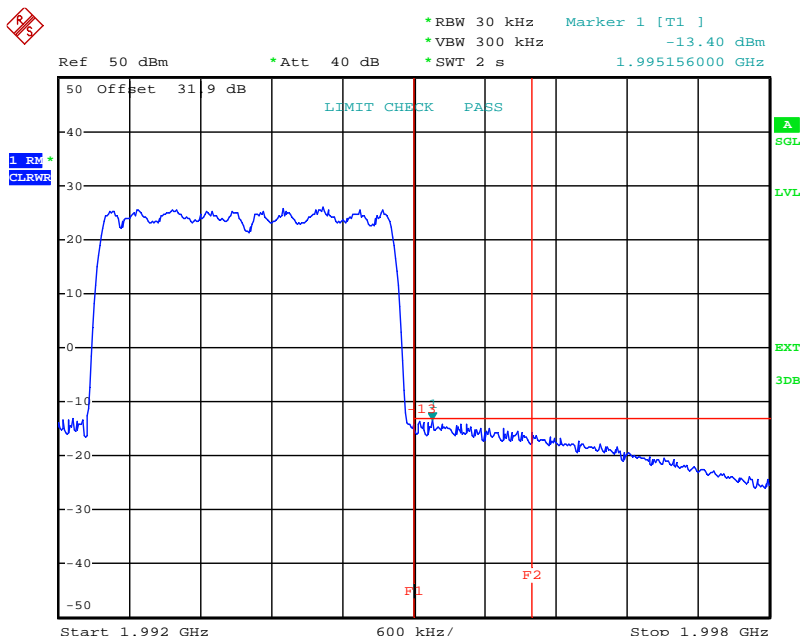

Date: 12.OCT.2011 16:33:14

plot 7.3.1.3-#2 Spurious Emissions at Antenna Terminals: §24.238, §2.1051; Test results; Downlink; CDMA < 1MHz to band edge Upper Band Edge



7.3.1.4 W-CDMA < 1MHz to band edge

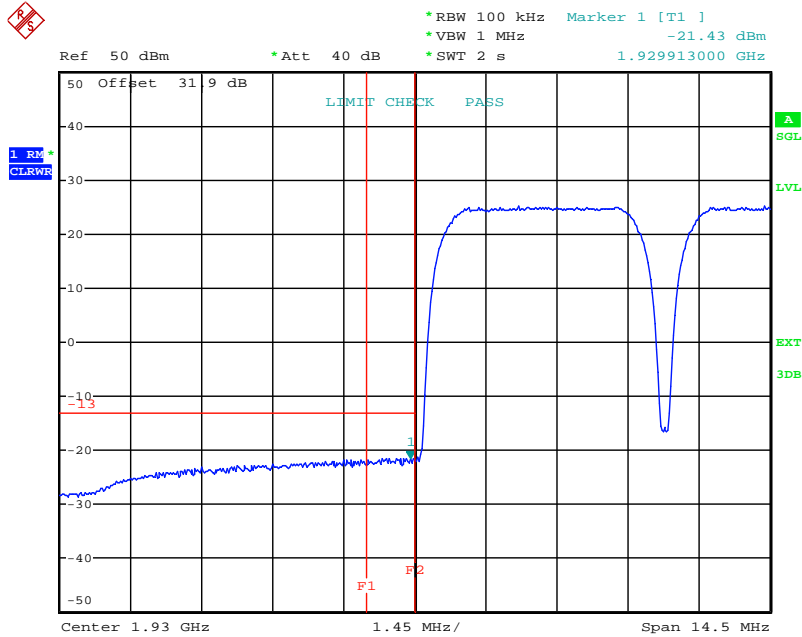

Date: 12.OCT.2011 16:04:01

plot 7.3.1.4-#1 Spurious Emissions at Antenna Terminals: §24.238, §2.1051; Test results; Downlink; W-CDMA < 1MHz to band edge Lower Band Edge

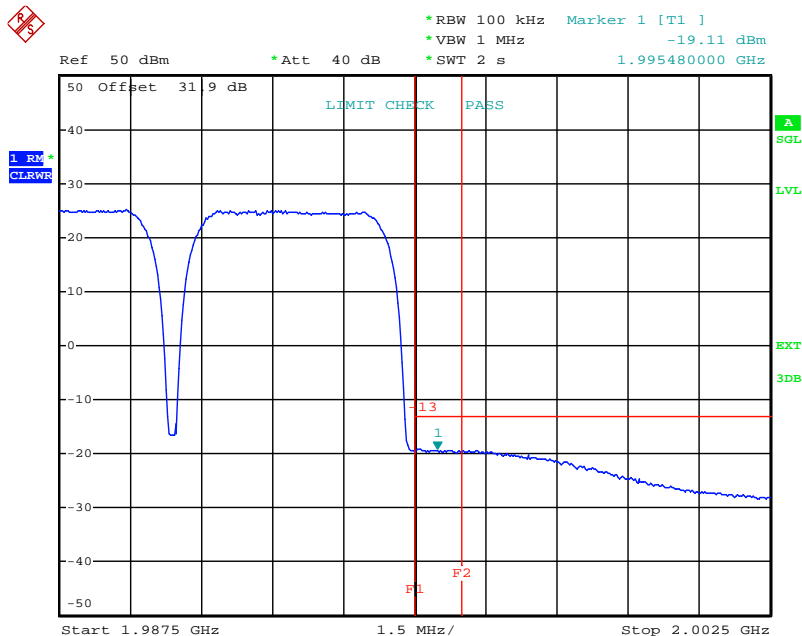

Date: 12.OCT.2011 16:30:33

plot 7.3.1.4-#2 Spurious Emissions at Antenna Terminals: §24.238, §2.1051; Test results; Downlink; W-CDMA < 1MHz to band edge Upper Band Edge



7.3.1.5 LTE < 1MHz to band edge

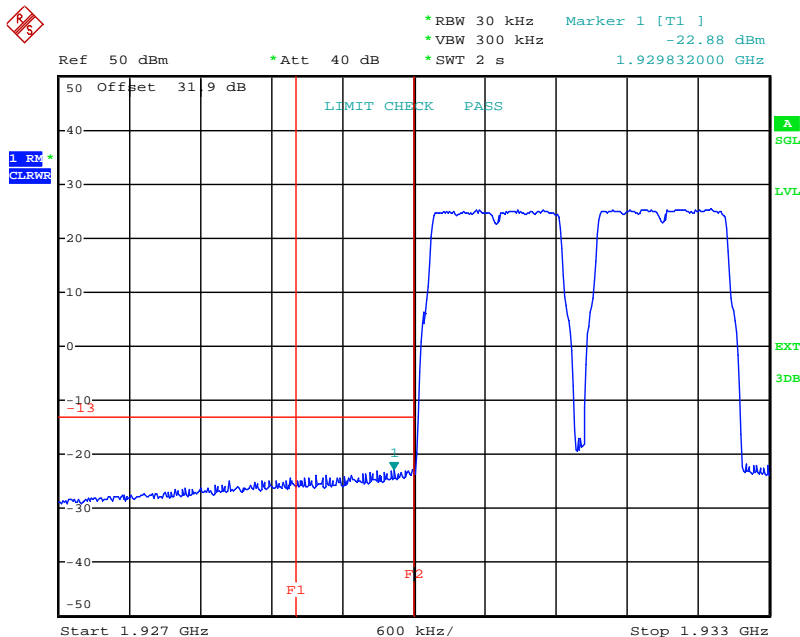

Date: 12.OCT.2011 16:13:07

plot 7.3.1.5-#1 Spurious Emissions at Antenna Terminals: §24.238, §2.1051; Test results; Downlink; LTE < 1MHz to band edge Lower Band Edge

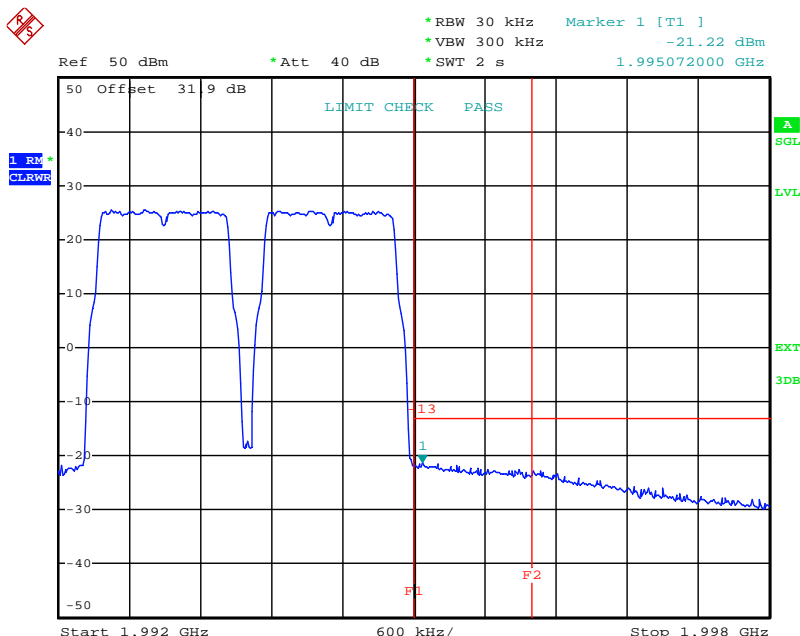

Date: 12.OCT.2011 16:25:53

plot 7.3.1.5-#2 Spurious Emissions at Antenna Terminals: §24.238, §2.1051; Test results; Downlink; LTE < 1MHz to band edge Upper Band Edge



7.3.1.6 GSM > 1MHz to band edge

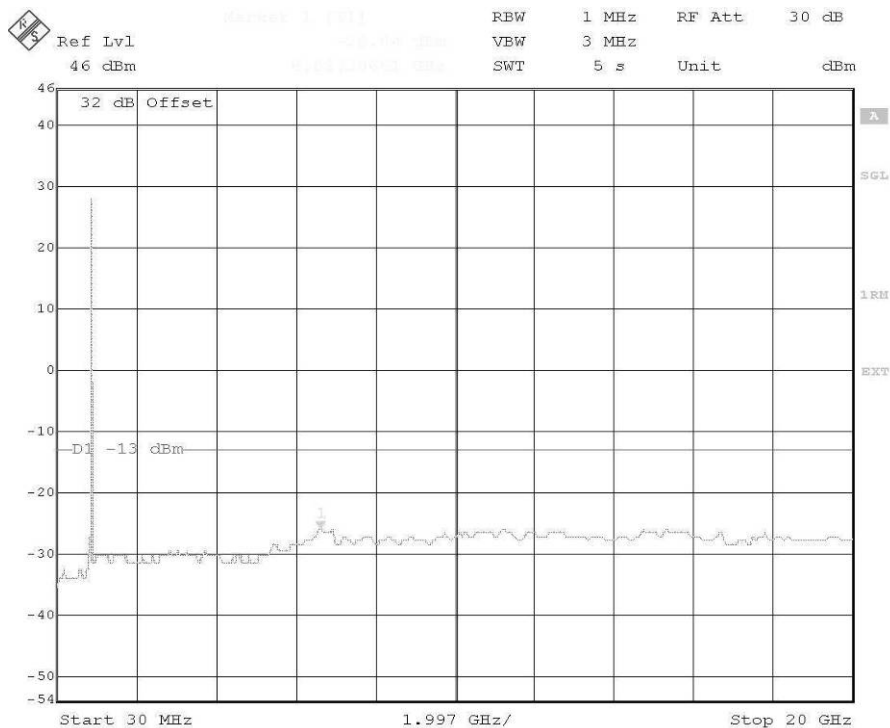

plot 7.3.1.6-#1 Spurious Emissions at Antenna Terminals: §24.238, §2.1051; Test results; Downlink; GSM > 1MHz to band edge; carrier (1962,5MHz) notched

7.3.1.7 GSM-EDGE > 1MHz to band edge

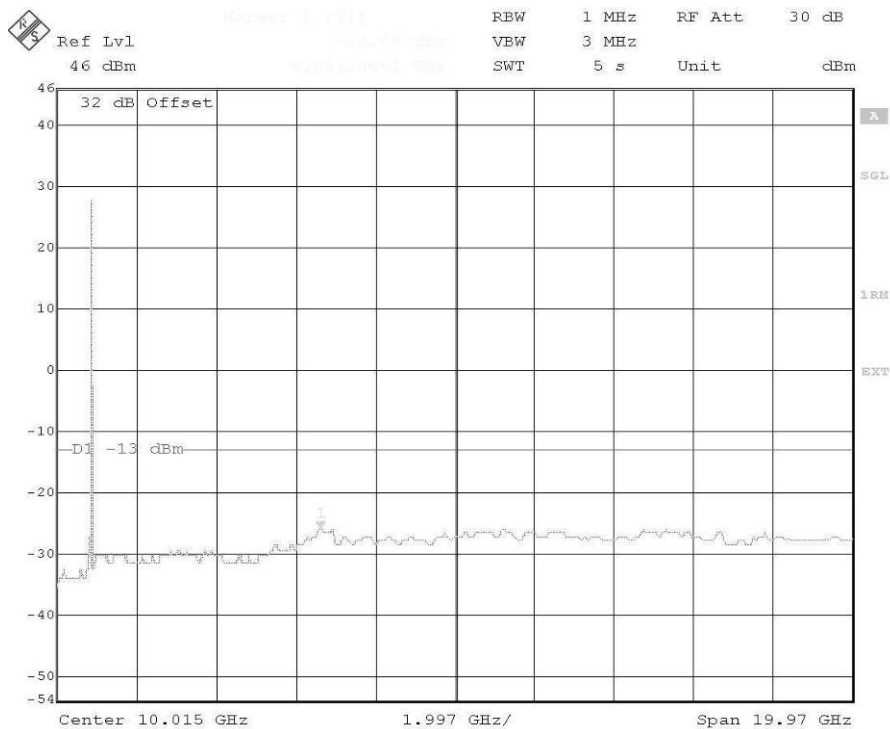

plot 7.3.1.7-#1 Spurious Emissions at Antenna Terminals: §24.238, §2.1051; Test results; Downlink; GSM-EDGE > 1MHz to band edge; carrier (1962,5MHz) notched



7.3.1.8 CDMA > 1MHz to band edge

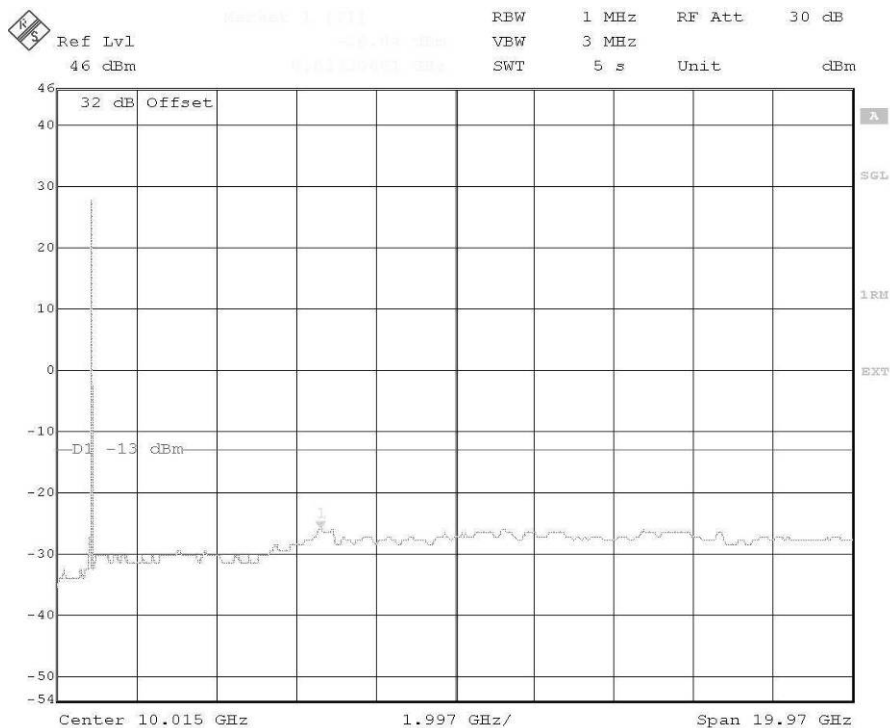

Date: 13.OCT.2011 17:34:15

plot 7.3.1.8-#1 Spurious Emissions at Antenna Terminals: §24.238, §2.1051; Test results; Downlink; CDMA > 1MHz to band edge; carrier (1962,5MHz) notched

7.3.1.9 W-CDMA > 1MHz to band edge

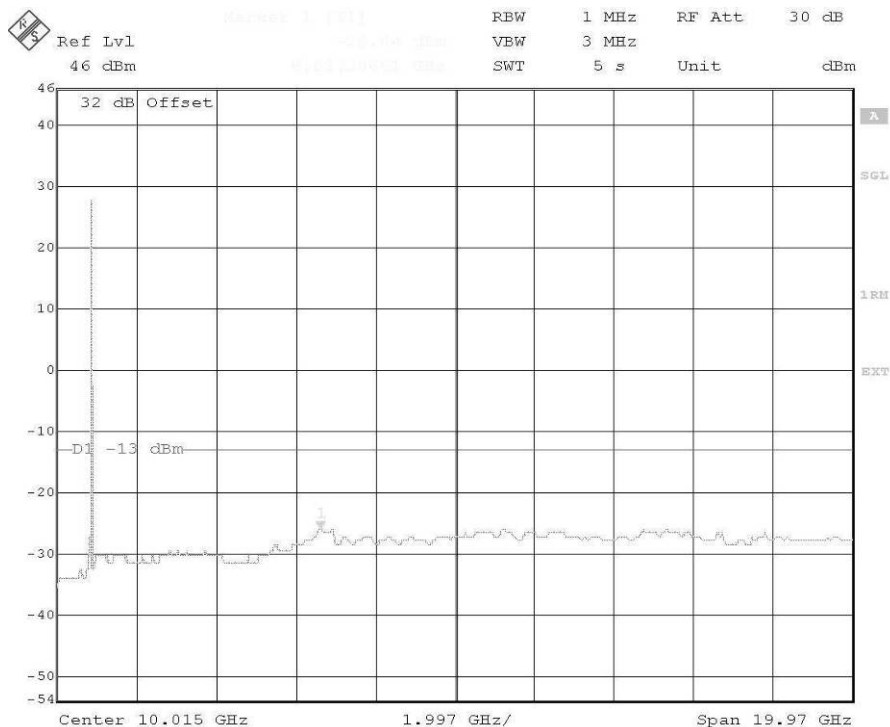

Date: 13.OCT.2011 17:35:20

plot 7.3.1.9-#1 Spurious Emissions at Antenna Terminals: §24.238, §2.1051; Test results; Downlink; W-CDMA > 1MHz to band edge; carrier (1962,5MHz) notched



7.3.1.10 LTE > 1MHz to band edge

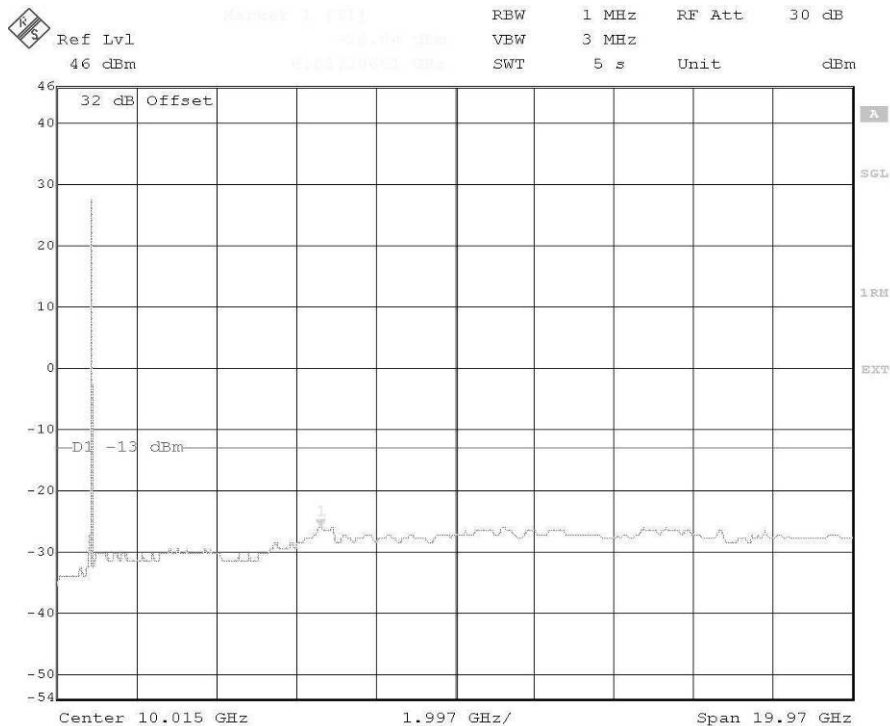

Date: 13.OCT.2011 17:36:24

plot 7.3.1.10-#1 Spurious Emissions at Antenna Terminals: §24.238, §2.1051; Test results; Downlink; LTE > 1MHz to band edge; carrier (1962,5MHz) notched

7.3.2 Uplink

n.a.

Note: The EUT does not transmit over the air in the uplink direction.

7.4 Summary test result

Test result	complies, according the plots above
Tested by:	Ph. Wagner
Date:	12.10.2011

8 Radiated Spurious Emissions: §24.238, §2.1053, RSS-133



picture 8.1: name plate



picture 8.2: Test setup: Field Strength Emission <1 GHz @3m in the FAC

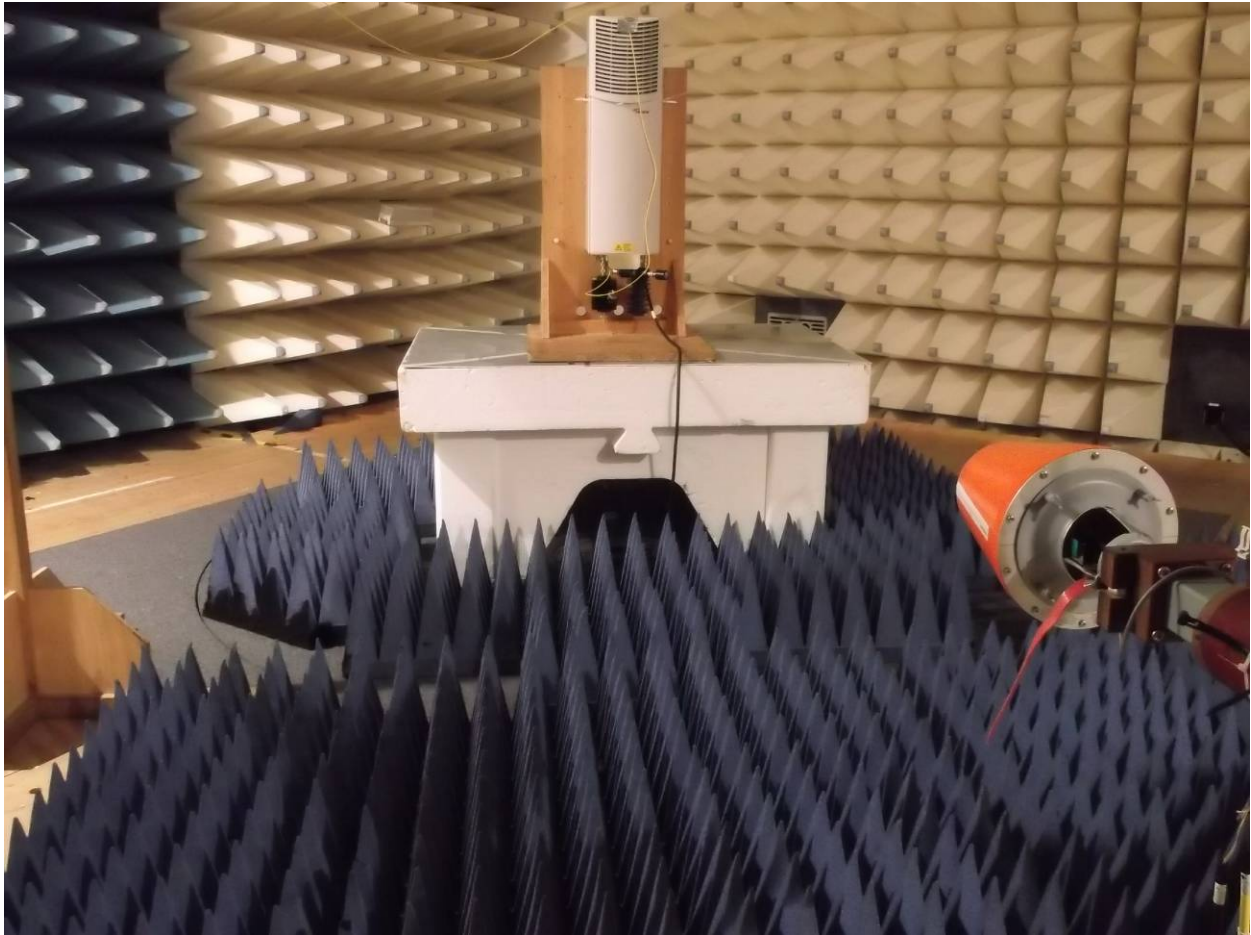

picture 8.3: Test setup: Field Strength Emission >1 GHz @3m in the FAC

Test Report No.: 11-252

FCC ID: XS5-M778519P

IC ID: 2237E-M778519P



This clause specifies requirements for the measurement of radiated emission.

Frequency range	Distance: EUT <-> antenna / location	Limit	Test method
30 MHz - 1 GHz	3 metres / FAC	FCC 47 CFR Part 24.238 IC RSS-133 sec. 6.5	TIA/EIA-603-C:2004
1 GHz – 20 GHz	3 metres / FAC	FCC 47 CFR Part 24.238 IC RSS-133 sec. 6.5	

Test equipment used:

Designation	Type	Manufacturer	Invent.-no.	Cal.-date	due Cal.- date	used
EMI test receiver	ESI40	Rohde & Schwarz	E1607	23.05.2011	23.05.2012	X
Antenna	CBL 6111	Chase	K1149	02.08.2011	02.08.2012	X
RF Cable		Frankonia	K1121 SET	14.07.2011	14.07.2012	X
Pre amplifier	AM1431	Miteq	K1721	14.07.2011	14.07.2012	X
Antenna	HL 025	R&S	K809	25.07.2011	25.07.2012	X
RF Cable	Sucoflex 100	Suhner	K1742	05.04.2011	05.04.2012	X
Preamplifier	AFS4-00102000	Miteq	K838	09.02.2011	09.02.2012	X

The REMI version 2.135 has been used for max search.

Test set-up:

Test location: FAC
Both, the Fully Anechoic Chamber (FAC) and the Semi Anechoic Chamber (SAC) fulfil the requirements of ANSI C63.4 and CISPR 16-1-4 with regards to NSA and SVSWR.

Test Voltage: 115V / 60 Hz
Type of EUT: Wall mounted

Measurement uncertainty:

Measurement uncertainty expanded (95% or K=2)	± 4,7 dB for ANSI C63.4 measurement ± 0,5 dB for TIA-603 measurement
--	---



8.1 Limit §24.238

The rules in this section govern the spectral characteristics of emissions in the Broadband Personal Communications Service.

(a) *Out of band emissions.* The power of any emission outside of the authorized operating frequency ranges must be attenuated below the transmitting power (P) by a factor of at least $43 + 10 \log(P)$ dB.

(b) *Measurement procedure.* Compliance with these rules is based on the use of measurement instrumentation employing a resolution bandwidth of 1 MHz or greater. However, in the 1 MHz bands immediately outside and adjacent to the frequency block a resolution bandwidth of at least one percent of the emission bandwidth of the fundamental emission of the transmitter may be employed. A narrower resolution bandwidth is permitted in all cases to improve measurement accuracy provided the measured power is integrated over the full required measurement bandwidth (i.e. 1 MHz or 1 percent of emission bandwidth, as specified). The emission bandwidth is defined as the width of the signal between two points, one below the carrier center frequency and one above the carrier center frequency, outside of which all emissions are attenuated at least 26 dB below the transmitter power.

The limit is **-13dBm** (e.i.r.p).

8.2 Test method ANSI/TIA/EA-603-C

Measurement procedure. TIA-603-C

The antenna substitution method is used to determine the equivalent radiated power at spurious frequencies. The spurious emissions are measured at a distance of 3 meters. The EUT is then replaced with a reference substitution antenna with a known gain referenced to a dipole. This antenna is fed with a signal at the spurious frequency. The level of the signal is adjusted to repeat the previously measured level. The resulting eirp is the signal level fed to the reference antenna corrected for gain referenced to an isotropic dipole (see Figure 7.2).

From KDB (AMPLIFIER, BOOSTER, AND REPEATER REMINDER SHEET):

Radiated spurs (enclosure) – Use of CW signal (low, mid. and high freq.) is acceptable rather than all modulations.

The maximum RFI field strength was determined during the measurement by rotating the turntable (± 180 degrees) and varying the height of the receive antenna ($h = 1 \dots 4$ m) as like defined in ANSI C63.4. A measurement receiver has been used with a RBW 120 kHz up to 1 GHz and 1 MHz above 1 GHz. Steps with during pre measurement was half the RBW.

Both, the Fully Anechoic Chamber (FAC) and the Semi Anechoic Chamber (SAC) fulfil the requirements of ANSI C63.4 and CISPR 16-1-4 with regards to NSA and SVSWR.

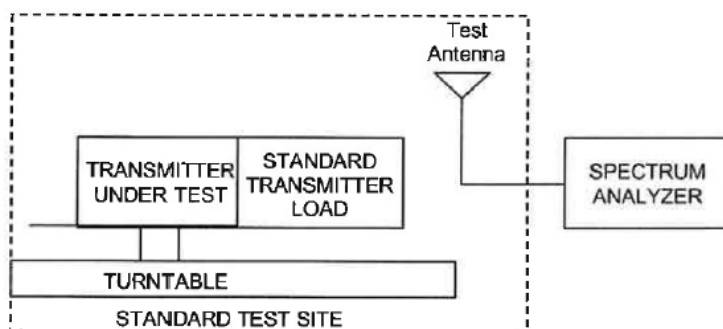

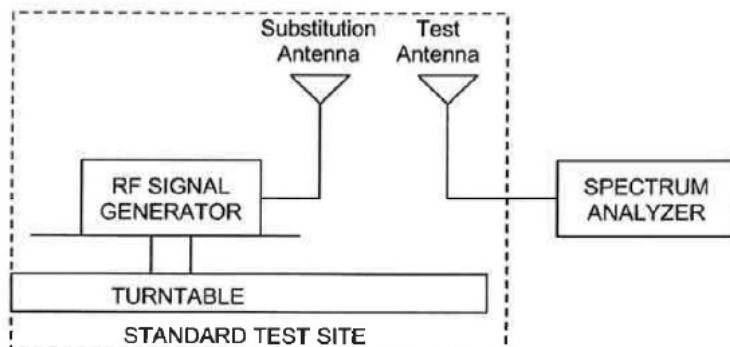

picture 8.3: Substitution method

8.3 Climatic values in the lab

Temperature: 20°
Relative Humidity: 45%
Air-pressure: 1009hPa

Test Report No.: 11-252

FCC ID: XS5-M778519P

IC ID: 2237E-M778519P



8.4 Test results

8.4.1 30 MHz to 1 GHz Downlink (Bottom – Middle – Top)

Bottom 1930 MHz; Middle 1962,5 MHz; Top 1995 MHz

Horizontal / Vertikal

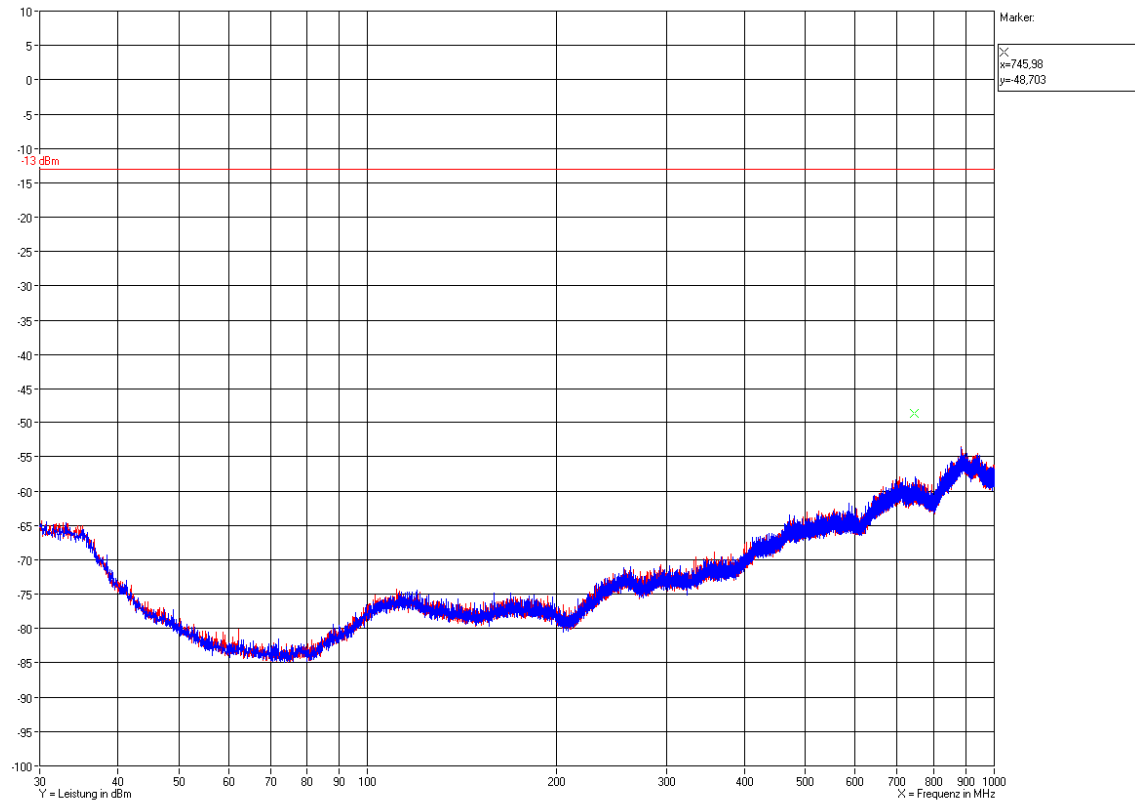

Test Report No.: 11-252

FCC ID: XS5-M778519P

IC ID: 2237E-M778519P



8.4.2 30 MHz to 1 GHz Downlink (Middle of all carriers)

f1 = 737 MHz

f2 = 751.5 MHz

f3 = 881.5 MHz

Horizontal / Vertikal

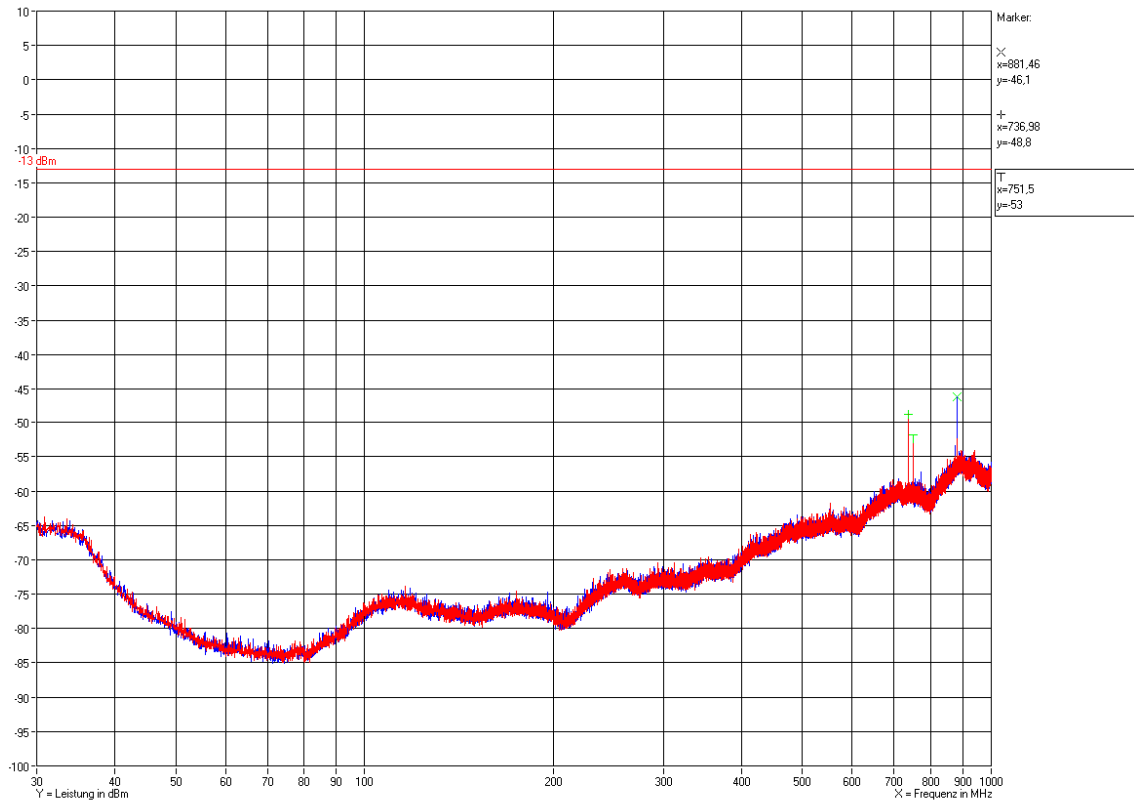

Test Report No.: 11-252

FCC ID: XS5-M778519P

IC ID: 2237E-M778519P



8.4.3 1 GHz -22 GHz Downlink (Bottom – Middle – Top)

Bottom 1930 MHz; Middle 1962,5 MHz; Top 1995 MHz

Horizontal / Vertikal

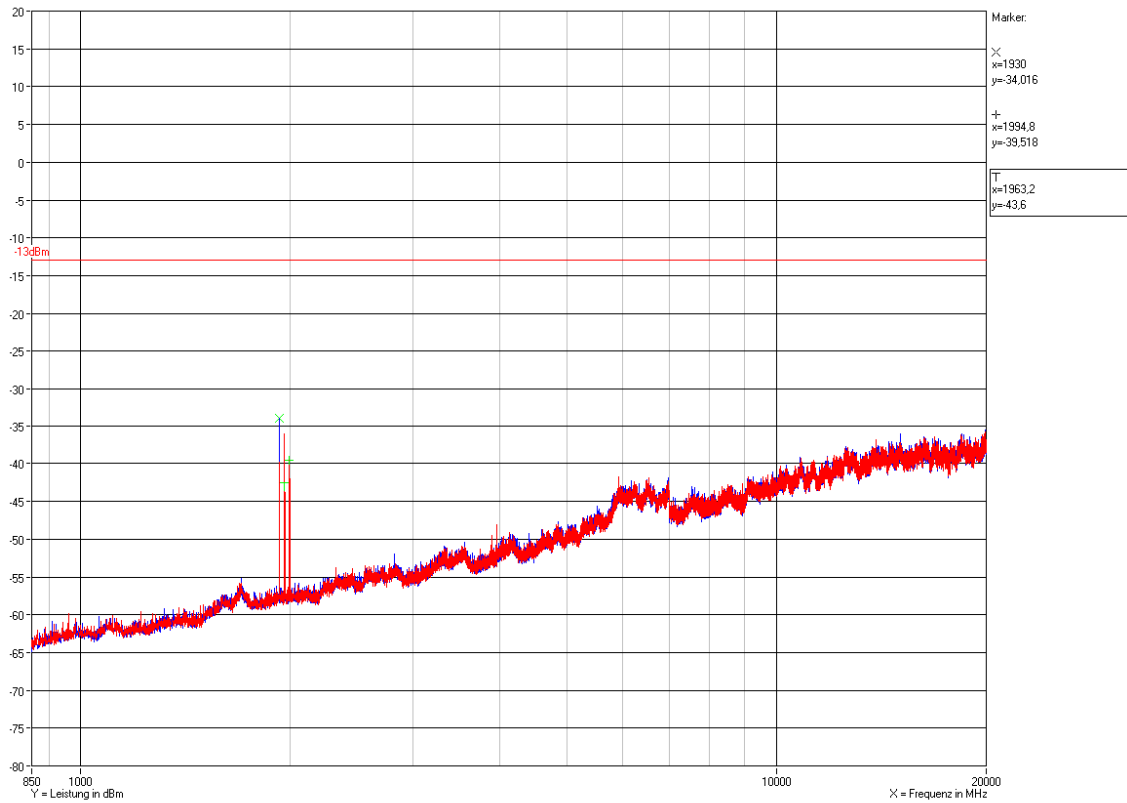



8.4.4 30 MHz to 1 GHz Downlink (Middle of all carriers)

f1 = 737 MHz

f2 = 751.5 MHz

f3 = 881.5 MHz

Horizontal / Vertikal

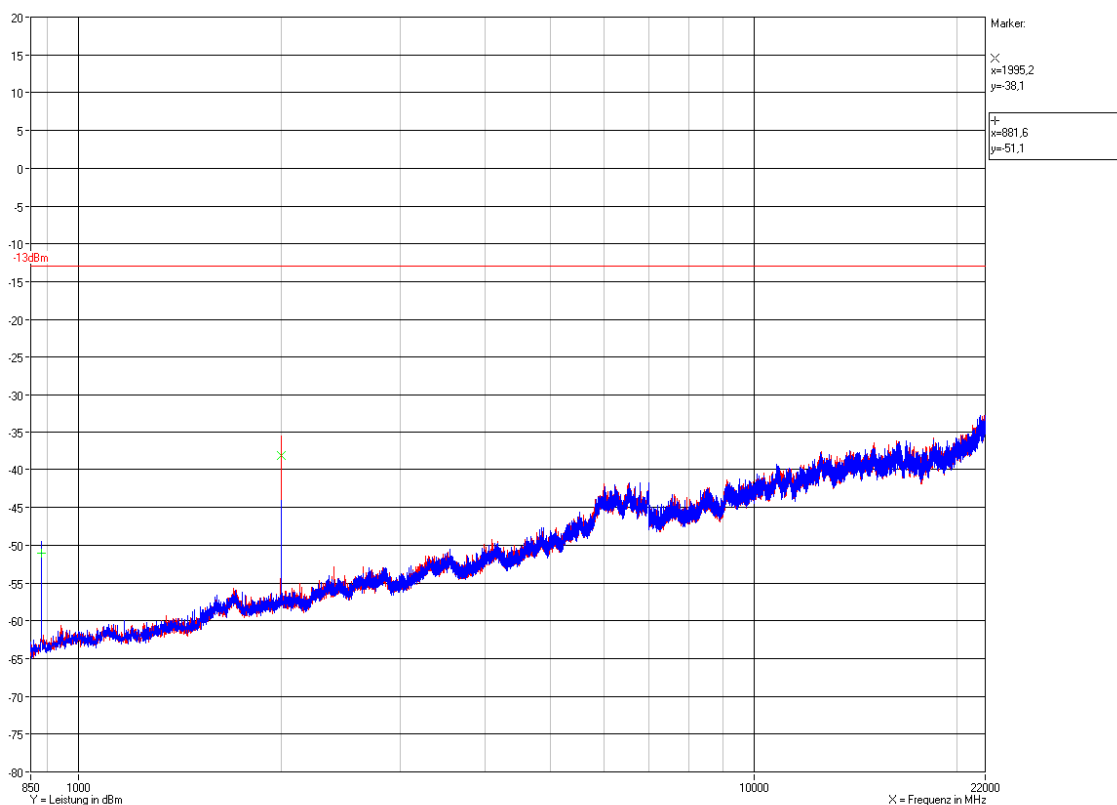

There were no spurious emissions detected other than noise and the fundamental.

Test Report No.: 11-252

FCC ID: XS5-M778519P

IC ID: 2237E-M778519P



8.4.5 History

Revision	Modification	Date	Name
V01.00	Initial Report	19.10.2011	T. Zahlmann

******* End of test report *******