

## IEEE802.15.4 / ZigBee uFL Module Family

**Overview**

This MD-102FC-5148A ZigBee Module built with a u.FL connector is a surface mount module with 1mW output power that enables users to implement IEEE802.15.4 or ZigBee PRO networking applications with minimum time to market and at the lowest cost. They remove the need for expensive and lengthy development of custom RF board designs and test suites. The modules provide a comprehensive solution with high radio performance and all RF components included. All that is required to develop and manufacture wireless control or sensing products is to connect a power supply and peripherals such as switches, actuators and sensors, considerably simplifying product development.

**Benefits**

- Microminiature module solutions
- Ready to use in products
- Minimizes product development time
- No RF test required for systems
- Compliant with FCC part 15 rules, IC Canada

**Features: Module**

- 2.4GHz IEEE802.15.4 & ZigBee PRO Compatible
- 2.3-3.6V for SOC
- Sleep Current ( with Active Sleep Timer ) 2.6µA
- Receiver Sensitivity -95dBm
- TX Power +2dBm
- TX Current 15mA
- RX Current 17.5mA
- Dimension : 32.2\*18\*3.5mm
- Weight : 3.0g

**Applications**

- Robust and secure low power wireless applications
- ZigBee PRO networks
- Home and commercial building automation
- Home networks
- Toys and gaming peripherals
- Industrial systems
- Telemetry and utilities (e.g. AMR)

**Features: Microcontroller**

- 32-Bit RISC CPU, up to 32MIPs with low power
- 128KB RAM, 128KB ROM
- 4Mbit serial flash for program code and data
- On chip OTP efuse
- JTAG debug interface
- 4-input 12-bit ADC, 2 12-Bit DACs, 2 Comparators
- 3 Application Timer / Counters, 3 System Timers
- 2 UARTs (One for In-System Debug)
- SPI Port with 5 Selects
- 2-Wire Serial Interface
- 4-wire digital audio interface
- Watchdog timer
- 21 GPIO

**Temperature Range**  
-40°C to +85°C

**Humidity**  
10 to 95% RH

**Lead-Free and RoHS Compliant**

Revised History		
Date	Revision	Description
2011/01/03	1.0	1 <sup>st</sup> Released

## Table of Contents

1.	Introduction.....	3
1.1	Key Features .....	3
1.1.1	Module.....	3
1.1.2	Microcontroller .....	3
1.2	Applications .....	3
2.	Specifications.....	4
3.	Pin Configurations .....	5
3.1	Pin Assignment .....	6
4.	Additional Information .....	8
4.1	Outline Drawing .....	8
4.2	Module PCB Footprint.....	9
4.3	Ordering / Lable Information .....	10
4.4	Tape and Reel Information.....	11
4.4.1	Tape Orientation and dimensions.....	11
4.4.2	Cover tape details.....	11
4.4.3	Leader and Trailer .....	12
4.4.4	Reel Dimensions .....	12
4.5	SMT IR Profile .....	13
4.6	How to Avoid ESD Damage to ICs.....	13
5.	FCC Statement .....	14
6.	IC Statement.....	16
7.	Contact Information .....	18

## **1. Introduction**

This MD-102FC-5148A ZigBee Module built with a u.FL connector is a surface mount module with 1mW output power that enables users to implement IEEE802.15.4 or ZigBee PRO networking applications with minimum time to market and at the lowest cost. They remove the need for expensive and lengthy development of custom RF board designs and test suites. The modules provide a comprehensive solution with high radio performance and all RF components included. All that is required to develop and manufacture wireless control or sensing products is to connect a power supply and peripherals such as switches, actuators and sensors, considerably simplifying product development.

### **1.1 Key Features**

#### **1.1.1 Module**

- 2.4GHz IEEE802.15.4 & ZigBee PRO Compatible
- 2.3 -3.6V for SOC
- Sleep Current ( with Active Sleep Timer ) 2.6 $\mu$ A
- Receiver Sensitivity -95dBm
- TX Power +2dBm
- TX Current 15mA
- RX Current 17.5mA
- Dimension : 32.2 \*18\*3.5mm
- Weight : 3.0g

#### **1.1.2 Microcontroller**

- 32-Bit RISC CPU
- 128KB RAM, 128KB ROM
- 4-input 12-bit ADC, 2 12-Bit DACs, 2 Comparators
- 3 Application Timer / Counters, 3 System Timers
- 2 UARTs
- SPI Port with 5 Selects
- 2-Wire Serial Interface
- 4-Wire digital audio interface
- 21 GPIO

### **1.2 Applications**

- Robust and secure low power wireless applications
- ZigBee PRO networks
- Home and commercial building automation
- Home networks
- Toys and gaming peripherals
- Industrial systems
- Telemetry and utilities (e.g. AMR)

## 2. Specifications

VDD=3.0V @ +25°C

Typical DC Characteristics		Notes
Deep Sleep Current	1.3uA	
Sleep Current	2.6uA	With active sleep timer
Radio Transmit Current	15mA	CPU in doze, radio transmitting
Radio Receive Current	17.5mA	CPU in doze, radio receiving
Centre Frequency Accuracy	±20ppm	Additional ±20ppm allowance for temperature and ageing
Typical RF Characteristics		Notes
Receive Sensitivity	-95dBm	Nominal for 1% PER, as per 802.15.4 section 6.5.3.3
Maximum Transmit Power (without PIFA Antenna)	+2dBm	
Total Transmit Current	15mA	
Total Receive Current	17.5mA	
Maximum Input Signal	+5dBm	For 1% PER, measured as sensitivity
RSSI Range	-95 to -10 dBm	
RF Port Impedance - uFL Connector	50 ohm	2.4 - 2.5GHz
VSWR (Max)	2:1	2.4 - 2.5GHz
Peripherals		Notes
Master SPI Port	5 selects	250kHz - 16MHz
Slave SPI Port	✓	250kHz - 8MHz
Two UARTs	✓	16550 compatible
TwoWire Serial I/F (Compatible with SMBus & I <sup>2</sup> C)	✓	Up to 400kHz
Two Programmable Timer/Counters with Capture/Compare Facility, Tick Timer	✓	16MHz clock
Two Programmable Sleep Timers	✓	32kHz clock
Digital IO Lines (Multiplexed with UARTs, Timers and SPI Selects)	21	
Four Channel Analogue-to-Digital Converter	✓	12-bit, up to 100ks/s
Two Channel Digital-to-Analogue Converter	✓	12-bit, up to 100ks/s
Two PProgrammable Analogue Comparators	✓	Ultra low power mode for sleep
Internal Temperature Sensor and Battery Monitor	✓	

**3. Pin Configurations**

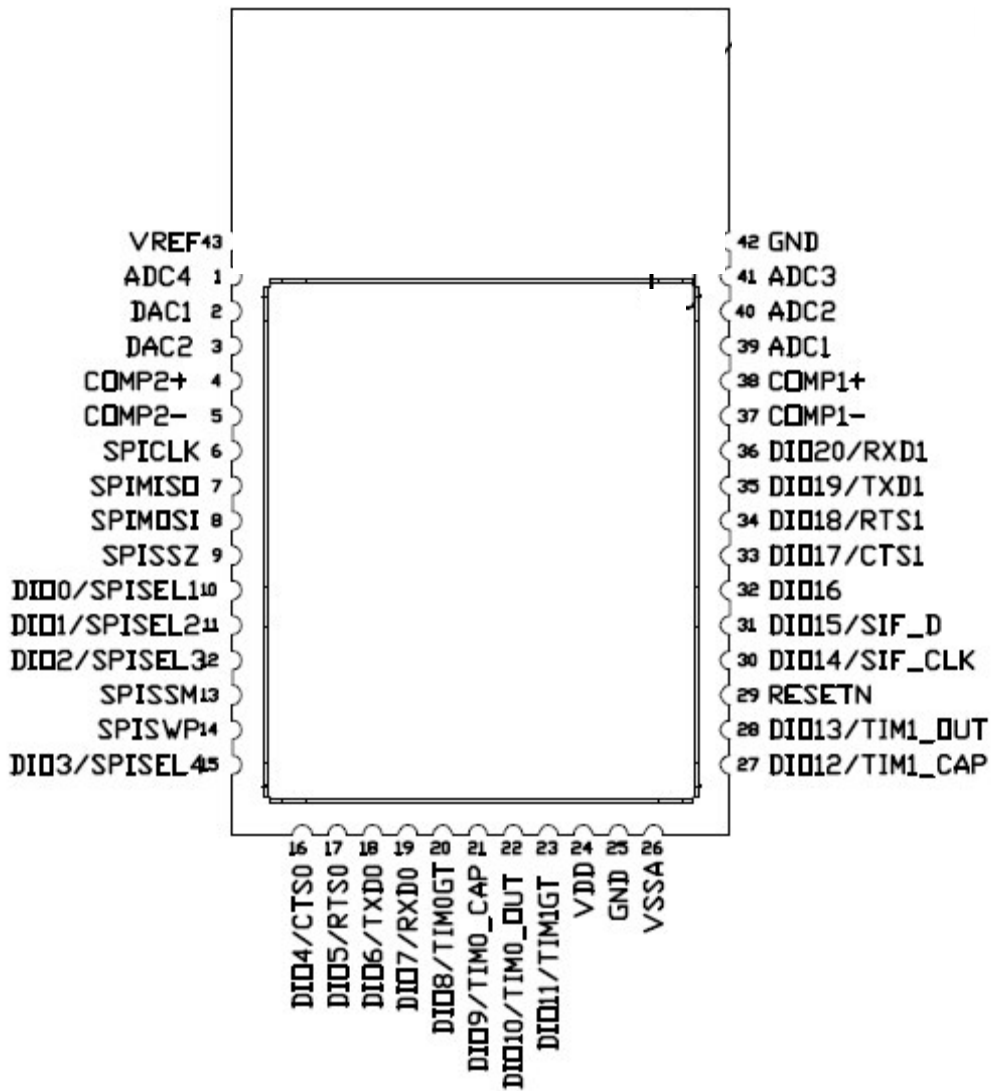

Figure : MD-102FC-5148A Pin Configuration(Top View)

### 3.1 Pin Assignment

Pin	Signal	Function	Alternative Function		
1	ADC4	Analogue to Digital input			
2	DAC1	Digital to Analogue output			
3	DAC2	Digital to Analogue output			
4	COMP2+	Comparator 2 inputs			
5	COMP2-				
6	SPICLK	SPI master clock out			
7	SPIMISO	SPI Master In/Slave Out			
8	SPIMOSI	SPI Master Out/Slave In			
9	SPISSZ	SPI select from module - SS0 (output)			
10	DIO0	DIO0 or SPI Slave Select1 (output)	SPISEL1		
11	DIO1	DIO1, SPI Slave Select2 (output) or Pulse Counter0 Input	SPISEL2	PC0	
12	DIO2	DIO2, SPI Slave Select3 (output) or Radio Receive Control Output	SPISEL3	RFRX	
13	SPISSM	SPI select to FLASH (input)			
14	SPISWP	FLASH write protect (input)			
15	DIO3	DIO3, SPI Slave Select4 (output) or Radio Transmit Control Output	SPISEL4	RFTX	
16	DIO4	DIO4, UART0 Clear To Send (input) or JTAG CLK	CTS0	JTAG_TCK	
17	DIO5	DIO5, UART0 Request To Send (output) or JTAG Mode Select	RTS0	JTAG_TMS	
18	DIO6	DIO6, UART0 Transmit Data (output) or JTAG Data Output	TXD0	JTAG_TDO	
19	DIO7	DIO7, UART0 Receive Data (input) or JTAG Data Input	RXD0	JTAG_TDI	
20	DIO8	DIO8, Timer0 clock/gate (input) or Pulse Counter1 Input	TIM0GT	PC1	
21	DIO9	DIO9, Timer0 capture (input), 32K External Crystal Input or 32K Clock Input	TIM0_CAP	32KXTALIN	32KIN
22	DIO10	DIO10, Timer0 PWM (output), 32K External Crystal Output	TIM0_OUT	32KXTALOUT	
23	DIO11	DIO11, Timer1 clock/gate (input) or Timer2 PWN Output	TIM1GT	TIM2OUT	
24	VDD	Supply Voltage			
25	GND	Digital ground			

Pin	Signal	Function	Alternative Function			
26	VSSA	Analogue ground				
27	DIO12	DIO12, Timer1 capture (input), Antenna Diversity or Digital Audio Word Select	TIM1_CAP	ADO	DAI_WS	
28	DIO13	DIO13, Timer1 PWM (output), Antenna Diversity or Digital Audio Data Input	TIM1_OUT	ADE	DAI_SDIN	
29	RESETN	Reset input				
30	DIO14	DIO14, Serial Interface clock or Intelligent peripheral clock Input	SIF_CLK	IP_CLK		
31	DIO15	DIO15, Serial Interface data or Intelligent peripheral data out	SIF_D	IP_DO		
32	DIO16	DIO16, Intelligent peripheral Data In	IP_DI			
33	DIO17	DIO17, UART1 Clear To Send (input), Intelligent Peripheral Device Select Input or Digital Audio Clock or JTAG CLK	CTS1	IP_SEL	DAI_SCK	JTAG_TCK
34	DIO18	DIO18, UART1 Request To Send (output), Intelligent Peripheral Interrupt Output or Digital Audio Data Output or JTAG Mode Select	RTS1	IP_INT	DAI_SDO UT	JTAG_TMS
35	DIO19	DIO19, UART1 Transmit Data (output) or JTAG Data Out	TXD1		JTAG_TDO	
36	DIO20	DIO20, UART1 Receive Data (input) or JTAG Data In	RXD1		JTAG_TDI	
37	COMP1-	Comparator 1 inputs				
38	COMP1+					
39	ADC1	Analogue to Digital input				
40	ADC2	Analogue to Digital input				
41	ADC3	Analogue to Digital input				
42	VSSA	Analogue ground				
43	VREF	Analogue peripheral reference voltage				

## 4. Additional Information

### 4.1 Outline Drawing

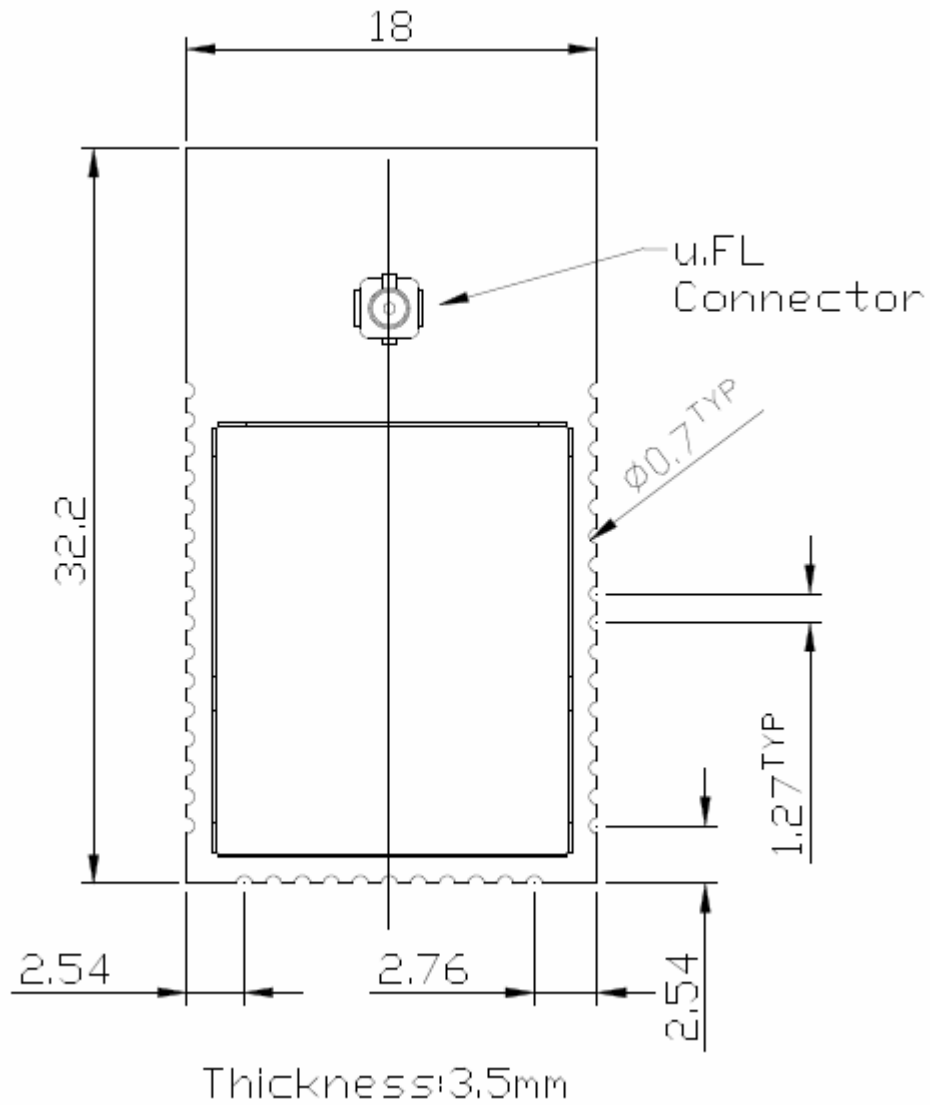

Figure : MD-102FC-5148A Outline Drawing



**4.2 Module PCB Footprint**

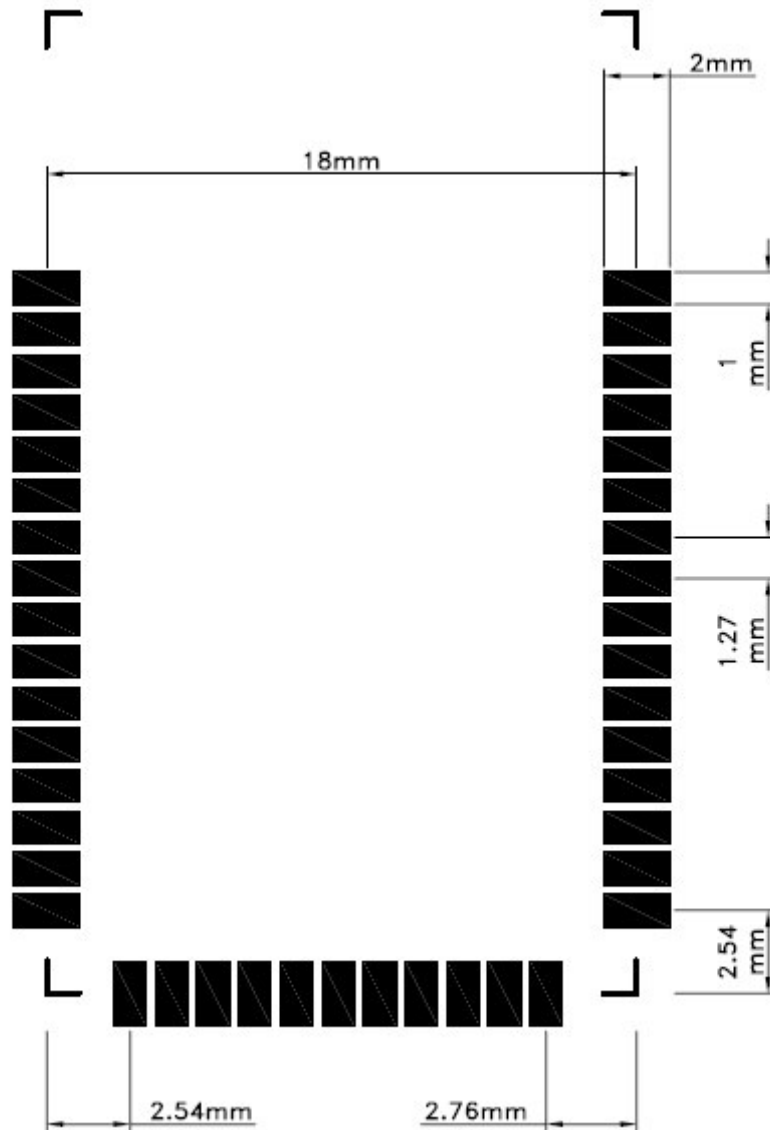
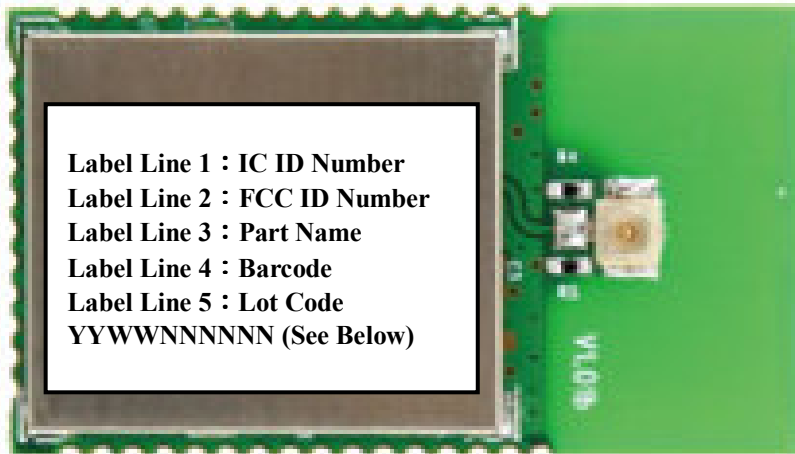

Figure : Module PCB footprint

**4.3 Ordering / Lable Information**



Label Line 1 : IC ID Number  
 Label Line 2 : FCC ID Number  
 Label Line 3 : Part Name  
 Label Line 4 : Barcode  
 Label Line 5 : Lot Code  
 YYWWNNNNNN (See Below)

Identifier	Description	Format
YY	Year	09 (Example)
WW	Week	34 (Example)
NNNNNN	Serial Number	000001 (Example)

Figure : Example MD-102FC-5148A Labeling for FCC Approved Modules

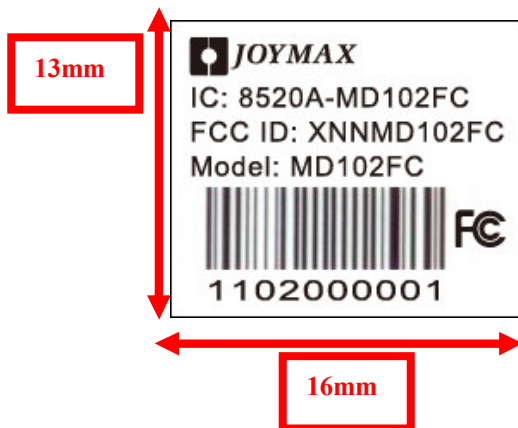

**4.4 Tape and Reel Information**

**4.4.1 Tape Orientation and dimensions**

All dimensions are in mm

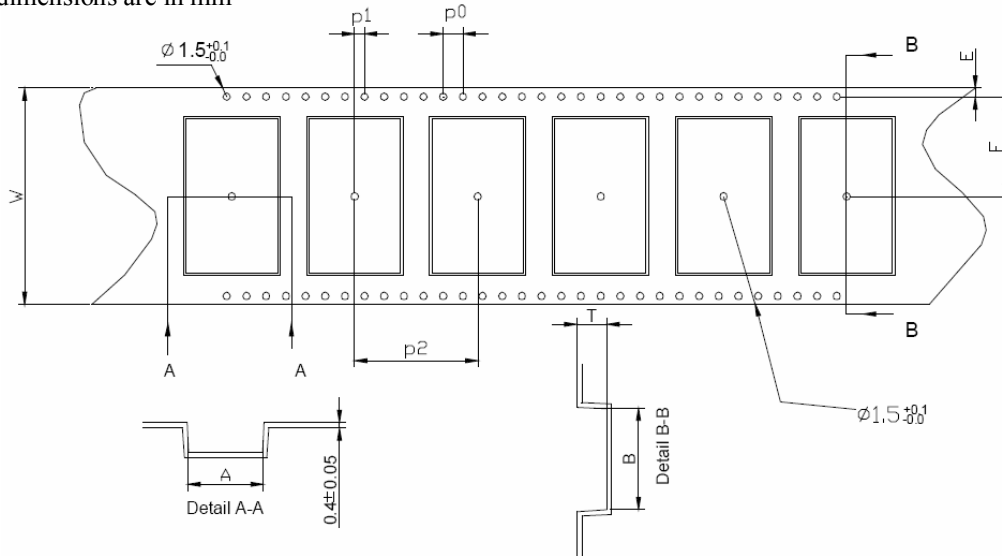

Module type	A	B	W	F	E	P0	P1	P2	T	Cover Tape width (W)
MD-102FC-5148A	18.5	32.7	44	20.2	1.75	4.0	2.0	24.0	3.4	37.5
Tolerance	±0.1	±0.1	±0.3	±0.1	+0.1	±0.1	±0.1	±0.1	±0.1	±0.1

**4.4.2 Cover tape details**

Thickness (T)	0.061mm
Surface resistivity (component side)	$10^4$ to $10^7$ Ohms/sq
Surface resistivity (component side)	Non-conductive
Backing type	Polyester
Adhesive type	PSA
Sealing	Room ambient

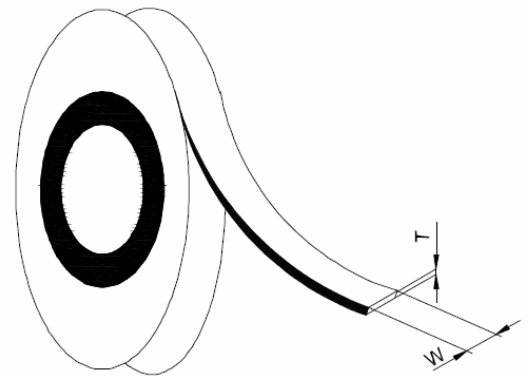

**4.4.3 Leader and Trailer**

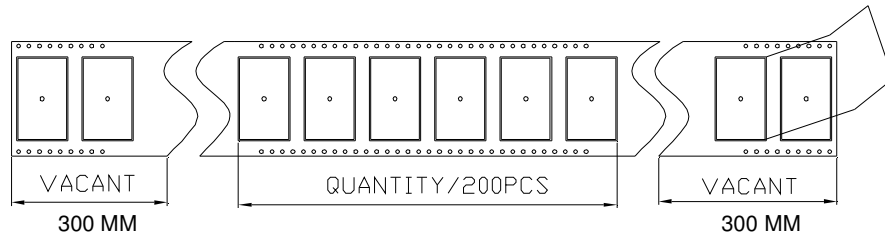

**4.4.4 Reel Dimensions**

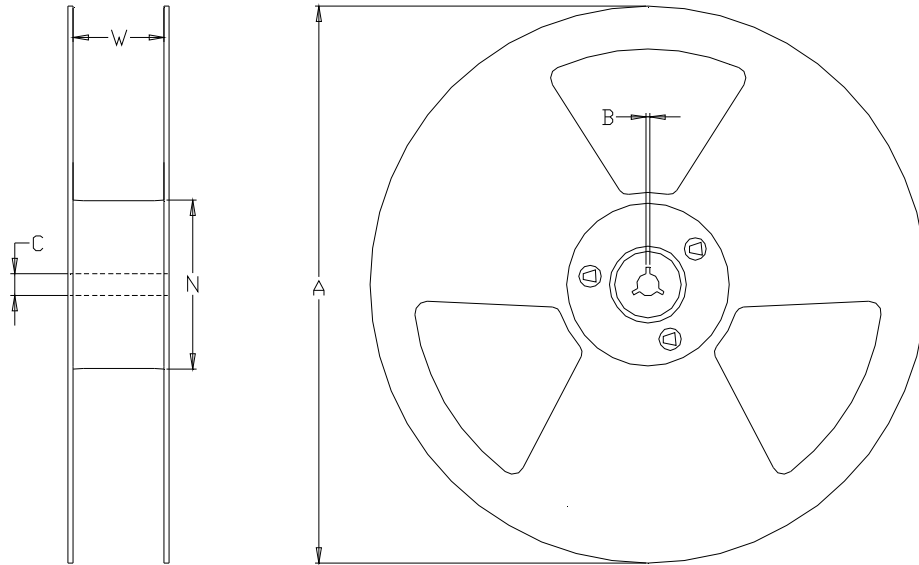

Module type:	A	B	C	N	W (min)
MD-120FA-5139A	330 ±1.0	2.2±0.5	13 ±0.2	100 +0.1	45.5±0.3

#### 4.5 SMT IR Profile

Average ramp-up rate (217C to peak): 3 °C /sec. max.

Preheat : 150~200 °C 、 60~180 seconds

Temperature maintained above 217 oC : 60~150 seconds

Time within 5 °C of actual peak temperature: 20 ~ 40 sec.

Peak temperature : 250+0/-5 °C

Ramp-down rate : 6 °C/sec. max.

Time 25 °C to peak temperature : 8 minutes max.

Cycle interval : 5 minus

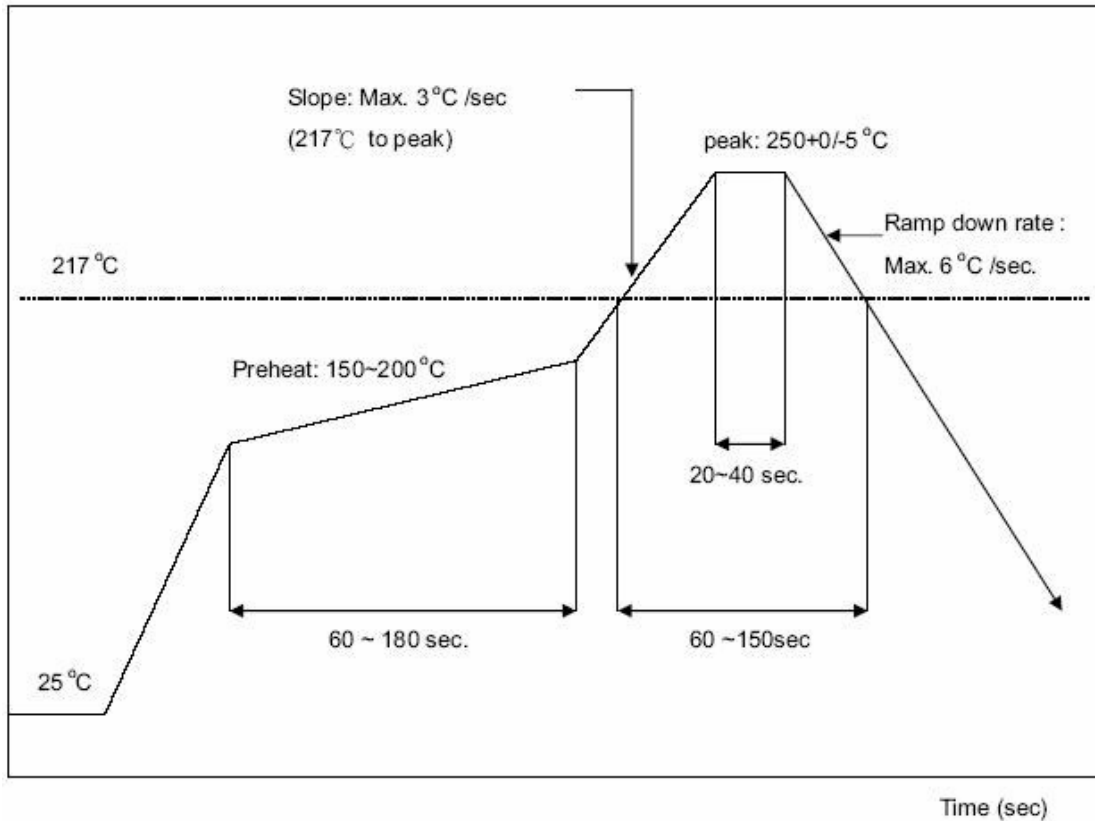

#### 4.6 How to Avoid ESD Damage to ICs

- \* Any person handling the ICs should be grounded either with a wrist strap or ESD-protective footwear used in conjunction with a conductive or static-dissipative floor or floor mat.
- \* The work surface where devices are placed for handling, processing, testing, etc., must be made of static-dissipative material and be grounded to ESD ground.
- \* All insulator materials must either be removed from the work area or must be neutralized with an ionizer. Static-generating clothing must be covered with an ESD-protective smock.
- \* When ICs are being stored, transferred between operations or workstations, or shipped, they must be kept in a Faraday shield container with inside surfaces (surfaces touching the ICs) that are static-dissipative.

## 5. FCC Statement

### Federal Communication Commission Interference Statement

This equipment has been tested and found to comply with the limits for a Class B digital device, pursuant to Part 15 of the FCC Rules. These limits are designed to provide reasonable protection against harmful interference in a residential installation. This equipment generates, uses and can radiate radio frequency energy and, if not installed and used in accordance with the instructions, may cause harmful interference to radio communications. However, there is no guarantee that interference will not occur in a particular installation. If this equipment does cause harmful interference to radio or television reception, which can be determined by turning the equipment off and on, the user is encouraged to try to correct the interference by one of the following measures:

- Reorient or relocate the receiving antenna.
- Increase the separation between the equipment and receiver.
- Connect the equipment into an outlet on a circuit different from that to which the receiver is connected.
- Consult the dealer or an experienced radio/TV technician for help.

FCC Caution: Any changes or modifications not expressly approved by the party responsible for compliance could void the user's authority to operate this equipment.

This device complies with Part 15 of the FCC Rules. Operation is subject to the following two conditions: (1) This device may not cause harmful interference, and (2) this device must accept any interference received, including interference that may cause undesired operation.

This device and its antenna(s) must not be co-located or operation in conjunction with any other antenna or transmitter.

### IMPORTANT NOTE:

This module is intended for OEM integrator. The OEM integrator is still responsible for the FCC compliance requirement of the end product, which integrates this module.

Any changes or modifications not expressly approved by the manufacturer could void the user's authority to operate this equipment.

### USERS MANUAL OF THE END PRODUCT:

The end user has to be informed that the FCC radio-frequency exposure guidelines for an uncontrolled environment can be satisfied. The end user has to also be informed that any changes or modifications not expressly approved by the manufacturer could void the user's authority to operate this equipment. If the size of the end product is smaller than 8x10cm, the FCC part 15.19 statement is required to be available in the users manual: This device complies with Part 15 of FCC rules. Operation is subject to the following two conditions: (1) this device may not cause harmful interference and (2) this device must accept any interference received, including interference that may cause undesired operation.

**LABEL OF THE END PRODUCT:**

The final end product must be labeled in a visible area with the following " Contains TX FCC ID: XNNMD102FC ". If the size of the end product is larger than 8x10cm, then the following FCC part 15.19 statement has to also be available on the label: This device complies with Part 15 of FCC rules. Operation is subject to the following two conditions: (1) this device may not cause harmful interference and (2) this device must accept any interference received, including interference that may cause undesired operation.

## **6. IC Statement**

**This Class B digital apparatus complies with Canadian ICES-003.**

**Egy'crr ctgkpw 2tks w'f g'ic'ercug'D'gu'eqphqto g'a 'ic'pqt o g'PO D/225'f w'Ecpcf c0**

Operation is subject to the following two conditions: (1) this device may not cause interference, and (2) this device must accept any interference, including interference that may cause undesired operation of the device.

This device and its antenna(s) must not be co-located or operation in conjunction with any other antenna or transmitter.

This module is intended for OEM integrator. The OEM integrator is still responsible for the IC compliance requirement of the end product, which integrates this module.





**USERS MANUAL OF THE END PRODUCT:**

The end user has to be informed that the IC radio-frequency exposure guidelines for an uncontrolled environment can be satisfied. The end user has to also be informed that any changes or modifications not expressly approved by the manufacturer could void the user's authority to operate this equipment.

Following IC statements are required to be included in the users manual:

"This Class B digital apparatus complies with Canadian ICES-003." and

"Cet appareil numérique de la classe B est conforme à la norme NMB-003 du Canada."

"Operation is subject to the following two conditions: (1) this device may not cause harmful interference and (2) this device must accept any interference received, including interference that may cause undesired operation."

and

"Le présent appareil est conforme aux CNR d'Industrie Canada applicables aux

appareils radio exempts de licence. L'exploitation est autorisée aux deux conditions suivantes:

(1) l'appareil ne doit pas produire de brouillage, et (2) l'utilisateur de l'appareil doit accepter tout brouillage radioélectrique subi, même si le brouillage est susceptible d'en compromettre le fonctionnement."

**LABEL OF THE END PRODUCT:**

The final end product must be labeled in a visible area with the following

"Contains TX IC: 8520A-MD102FC ".

## **7. Contact Information**

### **Headquarter(Taiwan)**

**JOYMAX ELECTRONICS CO., LTD.**

No. 5, Dong Yuan Rd.2,  
Jhongli Industrial Park,  
Jhongli City, Taoyuan 32063,  
Taiwan, R.O.C.

Tel: +886-3-433-5698

Fax: +886-3-433-5798

E-mail: [info@joymax.com.tw](mailto:info@joymax.com.tw)

website: <http://www.joymax.com.tw>

<http://www.joymax-antenna.com>

### **Europe**

**Joymax Europe GmbH**

Buettgenbachstr. 10  
D-40549 Duesseldorf  
Germany

Tel : 49-211-984 937

Fax : 49-211-984 9399

E-mail : [info@joymax.de](mailto:info@joymax.de)

<http://www.joymax.de>

### **U.S.A.**

**Nearson Inc.**

7432 Alban Station Blvd. Suite B226  
Springfield, VA 22150  
U.S.A.

Tel : 1-703-9135552

Fax : 1-703-9135553

E-mail : [sales@nearson.com](mailto:sales@nearson.com)

<http://www.nearson.com>