FCC Test Report

Report No: WD-RF-R-210272-B0

Product Name : WIRELESS SPEAKER
Model Name : WS-B1A
FCC ID : XN6WSB1A
Applicant : Zylux Acoustic Corporation
Received Date : Aug. 24, 2021
Tested Date : Aug. 30, 2021 ~ Sep. 27, 2021
Applicable Standard : 47 CFR FCC Part 15, Subpart C (Section 15.247)
KDB 558074 D01 DTS Meas. Guidance v05
ANSI C63.10 : 2013



Wendell Industrial Co., Ltd
Wendell EMC & RF Laboratory

Caution:

This report sets forth our findings solely with respect to the test samples identified herein. The results set forth in this report are not indicative or representative of the quality or characteristics of the lot from which a test sample was taken or any similar or identical product unless specifically and expressly noted.

The test results shown in the test report are traceable to the national/international standard through the calibration report of the equipment.

Please note that the measurement uncertainty are provided for informational purpose only and are not used in determining the Pass/Fail results.

This report must not be used to claim product endorsement by TAF or any agency of the government.

The test report shall not be reproduced without the written approval of Wendell Industrial Co., Ltd..

Test Report

Issued Date: September 30, 2021

Project No.: 21Q032503

| | |
|--|---|
| Product Name | WIRELESS SPEAKER |
| Trade Name | YAMAHA |
| Model Name | WS-B1A |
| FCC ID | XN6WSB1A |
| Applicant | Zylux Acoustic Corporation |
| Manufacturer | Yamaha Corporation |
| EUT Rated Voltage | Battery 3.7V or 5Vdc/2A |
| EUT Test Voltage | Battery 3.7V |
| EUT Supports Radios Application | Bluetooth BR/EDR |
| Applicable Standard | 47 CFR FCC Part 15, Subpart C (Section 15.247) KDB 558074 D01 DTS Meas. Guidance v05 ANSI C63.10 : 2013 |
| Output Power | 6.21 dBm |
| Test Result | Complied |

Documented :



(Specialist / Emma Lu)

Technical Engineer :



(Deputy Section Manager / Jack Chang)

Approved :



(Project Manager / Gary Wu)

Table of Contents

| | |
|---|-----------|
| Document Revision History | 5 |
| Summary of Test Result..... | 6 |
| 1 Generation Information | 7 |
| 1.1 Applicant..... | 7 |
| 1.2 Manufacturer..... | 7 |
| 1.3 Description of Equipment under Test..... | 7 |
| 1.4 Test Mode Applicability And Tested Channel Detail | 10 |
| 1.5 Configuration of Tested System | 12 |
| 1.6 EUT Exercise Software | 12 |
| 1.7 Tested System Details..... | 13 |
| 1.8 Test Facility | 14 |
| 1.9 Measurement Uncertainty | 15 |
| 1.10 List of Test Equipment..... | 16 |
| 2 Test Result | 19 |
| 2.1 Antenna Requirement..... | 19 |
| 2.1.1 Applicable Standard..... | 19 |
| 2.1.2 Antenna Connected Construction | 19 |
| 2.1.3 Antenna Gain | 19 |
| 2.2 Peak Output Power Measurement..... | 20 |
| 2.2.1 Limit | 20 |
| 2.2.2 Test Setup..... | 20 |
| 2.2.3 Test Procedure..... | 20 |
| 2.2.4 Test Result | 21 |
| 2.3 Number of Hopping Frequency | 22 |
| 2.3.1 Limit | 22 |
| 2.3.2 Test Setup..... | 22 |
| 2.3.3 Test Procedure..... | 22 |
| 2.3.4 Test Result | 23 |
| 2.4 Hopping Channel Separation Measurement..... | 24 |
| 2.4.1 Limit | 24 |
| 2.4.2 Test Setup..... | 24 |
| 2.4.3 Test Procedure..... | 24 |
| 2.4.4 Test Result | 25 |
| 2.5 Dwell Time Measurement..... | 27 |
| 2.5.1 Limit | 27 |
| 2.5.2 Test Setup..... | 27 |
| 2.5.3 Test Procedure..... | 27 |
| 2.5.4 Test Result | 28 |
| 2.6 20dB Bandwidth Measurement..... | 30 |
| 2.6.1 Limit | 30 |
| 2.6.2 Test Setup..... | 30 |
| 2.6.3 Test Procedure..... | 30 |
| 2.6.4 Test Result | 31 |
| 2.7 Conducted Band Edges and Spurious Emission Measurement | 33 |
| 2.7.1 Limit | 33 |
| 2.7.2 Test Setup..... | 33 |

| | | |
|------------|--|-----------|
| 2.7.3 | Test Procedure..... | 33 |
| 2.7.4 | Test Result | 34 |
| 2.8 | Radiated Band Edges and Spurious Emission Measurement | 37 |
| 2.8.1 | Limit | 37 |
| 2.8.2 | Test Setup..... | 38 |
| 2.8.3 | Test Procedure..... | 39 |
| 2.8.4 | Duty Cycle | 40 |
| 2.8.5 | Test Result of Radiated Band Edge Measurement..... | 40 |
| 2.8.6 | Test Result of Radiated Spurious Emission Measurement | 49 |
| 2.9 | AC Conducted Emissions Measurement..... | 64 |
| 2.9.1 | Limit | 64 |
| 2.9.2 | Test Setup..... | 64 |
| 2.9.3 | Test Procedure..... | 65 |
| 2.9.4 | Test Result | 66 |

Attachment 1: EUT Test Photographs

Attachment 2: EUT Detailed Photographs

Document Revision History

| Report No. | Issue date | Description |
|-------------------|--------------------|----------------|
| WD-RF-R-210272-B0 | September 30, 2021 | Initial report |

Summary of Test Result

| Ref. Std. Clause | Test Items | Result |
|---------------------|--|--------|
| 15.203 15.247(C) | Antenna Requirement | Pass |
| 15.247(b)(1) | Peak Conducted Output Power | Pass |
| 15.247(a)(1) | Number of Hopping Frequency | Pass |
| 15.247(a)(1) | Hopping Channel Separation | Pass |
| 15.247(a)(1) | Dwell Time of Each Channel | Pass |
| 15.247(a)(1) | 20dB Bandwidth | Pass |
| 15.247(d) | Conducted Band Edges and Conducted Spurious Emission | Pass |
| 15.247(d) | Radiated Band Edges and Radiated Spurious Emission | Pass |
| 15.207 | AC Conducted Emission | Pass |

1 Generation Information

1.1 Applicant

Zylux Acoustic Corporation
 7F, 70, Rui Guang Road, Neihu District, Taipei 114, Taiwan

1.2 Manufacturer

Yamaha Corporation
 10-1, Nakazawa-cho, Naka-ku, Hamamatsu-shi, Shizuoka-ken, 430-8650 Japan

1.3 Description of Equipment under Test

| | |
|--|---|
| Product Name | WIRELESS SPEAKER |
| Model No. | WS-B1A |
| FCC ID | XN6WSB1A |
| Frequency Range | 2402~2480MHz |
| Number of Channels | 79 |
| Channel separation | 1MHz |
| Type of Modulation | FHSS: GFSK(1Mbps) / π /4DQPSK(2Mbps) / 8DPSK(3Mbps) |
| Antenna Information | Refer to the table "Antenna List" |
| EUT Supports Radios Application | Bluetooth BR/EDR |
| EUT Rated Voltage | Battery 3.7V or 5Vdc/2A |
| EUT Test Voltage | Battery 3.7V |
| EUT Serial Number | Z003081TV、Z003041TV |

Antenna List

| No. | Manufacturer | Model No. | Antenna Type | Peak Gain |
|-----|-----------------------------------|-----------|--------------|---------------------|
| 1 | KINGRF TECHNOLOGY CO., LTD. | BS-1B | FPCB Antenna | 2.15 dBi for 2.4GHz |

Remark: The antenna of EUT is conforming to FCC 15.203

Channel List

| Channel | Frequency (MHz) | Channel | Frequency (MHz) | Channel | Frequency (MHz) | Channel | Frequency (MHz) |
|---------|-----------------|---------|-----------------|---------|-----------------|---------|-----------------|
| 00 | 2402 | 20 | 2422 | 40 | 2442 | 60 | 2462 |
| 01 | 2403 | 21 | 2423 | 41 | 2443 | 61 | 2463 |
| 02 | 2404 | 22 | 2424 | 42 | 2444 | 62 | 2464 |
| 03 | 2405 | 23 | 2425 | 43 | 2445 | 63 | 2465 |
| 04 | 2406 | 24 | 2426 | 44 | 2446 | 64 | 2466 |
| 05 | 2407 | 25 | 2427 | 45 | 2447 | 65 | 2467 |
| 06 | 2408 | 26 | 2428 | 46 | 2448 | 66 | 2468 |
| 07 | 2409 | 27 | 2429 | 47 | 2449 | 67 | 2469 |
| 08 | 2410 | 28 | 2430 | 48 | 2450 | 68 | 2470 |
| 09 | 2411 | 29 | 2431 | 49 | 2451 | 69 | 2471 |
| 10 | 2412 | 30 | 2432 | 50 | 2452 | 70 | 2472 |
| 11 | 2413 | 31 | 2433 | 51 | 2453 | 71 | 2473 |
| 12 | 2414 | 32 | 2434 | 52 | 2454 | 72 | 2474 |
| 13 | 2415 | 33 | 2435 | 53 | 2455 | 73 | 2475 |
| 14 | 2416 | 34 | 2436 | 54 | 2456 | 74 | 2476 |
| 15 | 2417 | 35 | 2437 | 55 | 2457 | 75 | 2477 |
| 16 | 2418 | 36 | 2438 | 56 | 2458 | 76 | 2478 |
| 17 | 2419 | 37 | 2439 | 57 | 2459 | 77 | 2479 |
| 18 | 2420 | 38 | 2440 | 58 | 2460 | 78 | 2480 |
| 19 | 2421 | 39 | 2441 | 59 | 2461 | -- | -- |

Test Frequencies in each operating band

| Frequency range over which the device operates in each operating band (Note 1) | Number of test frequencies required | Location of test frequencies inside the operating frequency range (Note 1,2) |
|--|-------------------------------------|--|
| ≤ 1 MHz | 1 | near centre |
| > 1 MHz and ≤ 10 MHz | 2 | 1 near high end, 1 near low end |
| > 10 MHz | 3 | 1 near high end, 1 near centre, and 1 near low end |

Note 1: The frequency range over which the device operates in a given operating band is the difference between the highest and lowest frequencies on which the device can be tuned within that given operating band. The frequency range can be smaller than or equal to the operating band, but cannot be greater than the operating band.

Note 2: In the third column of table 1, “near” means as close as possible to or at the centre / low end / high end of the frequency range over which the device operates.

Firmware / Software Version

| | | |
|----------|------------------------------------|--|
| 1 | Product Name | WIRELESS SPEAKER |
| 2 | Model No. | WS-B1A |
| 3 | Test SW Version | BlueTest3 Ver 2.6.8 |
| 4 | RF power setting in TEST SW | <input type="checkbox"/> RF power setting was not able to alter during testing. <input checked="" type="checkbox"/> RF power setting was able to alter during testing. (See the following table) |

Parameters of test software setting

| Type of Modulation | Channel | Frequency (MHz) | Set Value |
|--------------------|---------|-----------------|-----------|
| BT(GFSK) | 00 | 2402 | 10 |
| | 39 | 2441 | 10 |
| | 78 | 2480 | 10 |
| BT($\pi/4$ DQPSK) | 00 | 2402 | 10 |
| | 39 | 2441 | 10 |
| | 78 | 2480 | 10 |
| BT(8DPSK) | 00 | 2402 | 10 |
| | 39 | 2441 | 10 |
| | 78 | 2480 | 10 |

1.4 Test Mode Applicability And Tested Channel Detail

1. This device is a WIRELESS SPEAKER with a built-in Wi-Fi 、Bluetooth and RFID transceiver.
2. These tests were performed on a sample of equipment to demonstrate compliance with 47 CFR FCC Part 15, Subpart C (Section 15.247).
3. Pre-Scan has been conducted to determine the worst-case mode from all possible combinations between available modulations, data rates, XYZ axis and antenna ports.
4. The worst case was found when positioned on X axis for radiated emission. Following test modes were selected for the final test, and the final worst case is recorded in the report:

| EUT Configure Mode | RE < 1G | RE ≥ 1G | ACM | ACP | Description |
|--------------------|-------------------------------------|-------------------------------------|-------------------------------------|-------------------------------------|-------------|
| -- | <input checked="" type="checkbox"/> | <input checked="" type="checkbox"/> | <input checked="" type="checkbox"/> | <input type="checkbox"/> | Transmit BT |
| -- | <input type="checkbox"/> | <input type="checkbox"/> | <input type="checkbox"/> | <input checked="" type="checkbox"/> | Normal Link |

Note : RE<1G: Radiated Emission below 1GHz RE≥1G: Radiated Emission above 1GHz
 ACM: Antenna Port Conducted Measurement ACP: AC Power Line Conducted Emission

Following channel(s) was (were) selected for the final test as listed below:

Radiated Spurious Emission Measurement(Below 1GHz):

| EUT Configure Mode | Mode | Available Channel | Tested Channel | Modulation Type | Data Rate (Mbps) |
|--------------------|------|-------------------|----------------|-----------------|------------------|
| -- | BT | 0 ~ 78 | 39 | GFSK | 1 |

Radiated Spurious Emission Measurement(Above 1GHz):

| EUT Configure Mode | Mode | Available Channel | Tested Channel | Modulation Type | Data Rate (Mbps) |
|--------------------|------|-------------------|----------------|-----------------|------------------|
| -- | BT | 0 ~ 78 | 0, 39, 78 | GFSK | 1 |
| -- | BT | 0 ~ 78 | 0, 39, 78 | 8DPSK | 3 |

Radiated Band Edge Emission Measurement(Above 1GHz):

| EUT Configure Mode | Mode | Available Channel | Tested Channel | Modulation Type | Data Rate (Mbps) |
|--------------------|------|-------------------|----------------|-----------------|------------------|
| -- | BT | 0 ~ 78 | 0, 78 | GFSK | 1 |
| -- | BT | 0 ~ 78 | 0, 78 | 8DPSK | 3 |

Peak Output Power, Hopping Channel Separation Measurement, 20dB Bandwidth, Conducted Spurious Emission:

| EUT Configure Mode | Mode | Available Channel | Tested Channel | Modulation Type | Data Rate (Mbps) |
|--------------------|------|-------------------|----------------|-----------------|------------------|
| -- | BT | 0 ~ 78 | 0, 39, 78 | GFSK | 1 |
| -- | BT | 0 ~ 78 | 0, 39, 78 | 8DPSK | 3 |

Number of Hopping Frequency, Dwell Time Measurement, Conducted Band Edges

| EUT Configure Mode | Mode | Available Channel | Tested Channel | Modulation Type | Data Rate (Mbps) |
|--------------------|------|-------------------|----------------|-----------------|------------------|
| -- | BT | 0 ~ 78 | Hopping | GFSK | 1 |
| -- | BT | 0 ~ 78 | Hopping | 8DPSK | 3 |

Conducted Band Edges

| EUT Configure Mode | Mode | Available Channel | Tested Channel | Modulation Type | Data Rate (Mbps) |
|--------------------|------|-------------------|----------------|-----------------|------------------|
| -- | BT | 0 ~ 78 | 0, 78 | GFSK | 1 |
| -- | BT | 0 ~ 78 | 0, 78 | 8DPSK | 3 |

AC Conducted Emission:

| EUT Configure Mode | Mode | Available Channel | Tested Channel | Modulation Type | Data Rate (Mbps) |
|--------------------|------|-------------------|----------------|-----------------|------------------|
| -- | BT | 0 ~ 78 | Hopping | GFSK | 1 |

1.5 Configuration of Tested System

Radiation

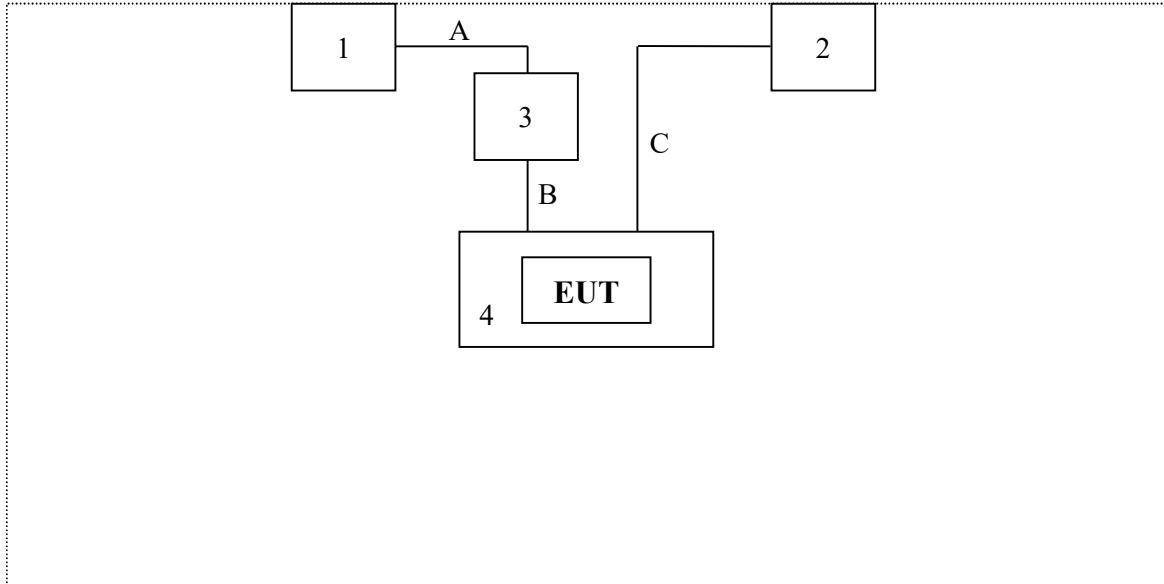

Test Table

AC Conduction

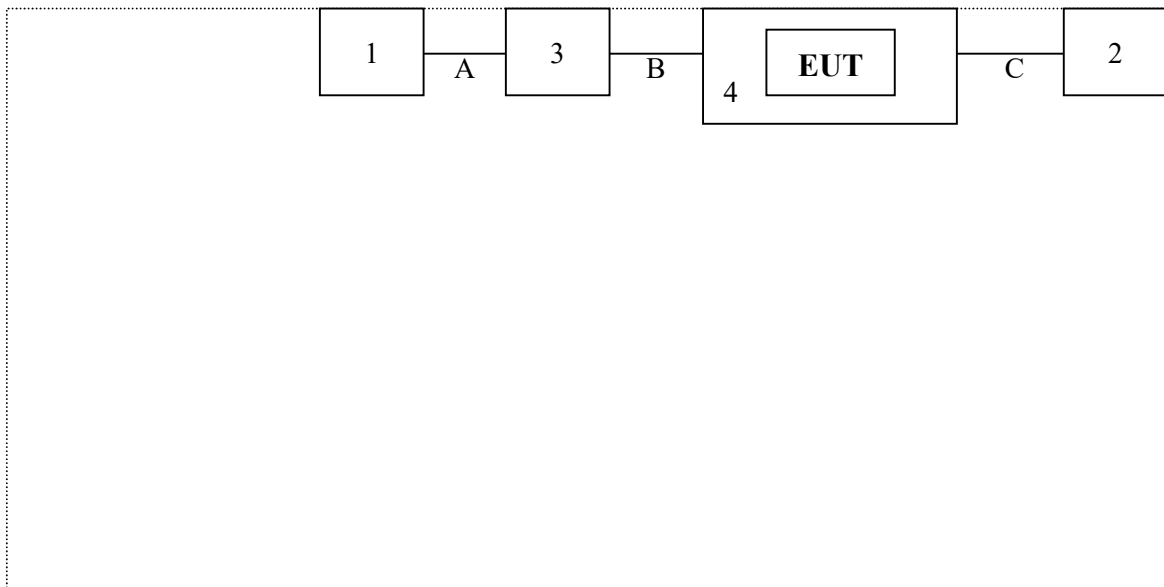

Test Table

1.6 EUT Exercise Software

1. Setup the EUT as shown in Section 1.5
2. Execute software “BlueTest3 Ver 2.6.8”.
3. Configure the test mode, the test channel, and the data rate.
4. Press “OK” to start the continuous transmit.
5. Verify that the EUT works properly.

1.7 Tested System Details

The types for all equipment, plus descriptions of all cables used in the tested system (including inserted cards) are:

| No. | Product | Manufacturer | Model No. | Serial No. | Power Cord |
|-----|----------------|--------------|-------------|------------------------|------------------------------|
| 1 | Notebook PC | acer | N16Q1 | NXVD4TA023742254707600 | Non-shielded, 1 Core, 0.8m |
| 2 | Adapter | APPLE | A2167 | N/A | N/A |
| 3 | Fixture | N/A | CSR USB-SPI | N/A | N/A |
| 4 | Charging stand | YAMAHA | CC-T1A | N/A | N/A |
| A | USB Cable | N/A | 2725 | N/A | Non-shielded, Non-Core, 0.7m |
| B | Data Cable | N/A | 2651 | N/A | Non-shielded, Non-Core, 0.2m |
| C | USB Cable | N/A | 2725 | N/A | Shielded, Non-Core, 1m |

1.8 Test Facility

| Items | Required (IEC 60068-1) | Actual |
|----------------------------|------------------------|----------|
| Temperature (°C) | 15-35 | 20~25 |
| Humidity (% RH) | 25-75 | 45~55 |
| Barometric pressure (mbar) | 860-1060 | 990~1020 |

Description: Accredited by TAF
Accredited Number: 2965

Issued by: Wendell Industrial Co., Ltd

Lab Address: 6F/6F-1, No.188, Baoqiao Rd., Xindian Dist.,
New Taipei City 23145, Taiwan R.O.C

Test Lab: Wendell EMC & RF Laboratory

Test Location: No. 119, Wugong 3rd Rd., Wugu Dist.,
New Taipei City 248, Taiwan (R.O.C.)

Designation Number: TW0025

Test Firm Registration Number: 665221

1.9 Measurement Uncertainty

ISO/IEC 17025 requires that an estimate of the measurement uncertainties associated with the emissions test results be included in the report. The measurement uncertainties given below are based on a 95% confidence (level based on a coverage factor K=2)

| Measurement Project | Condition | Expended Uncertainty |
|--------------------------------------|---------------------|----------------------|
| AC Conducted Emission | 0.150 ~ 30 MHz | 2.64 dB |
| Radiated Emission | 0.009 ~ 30 MHz | ± 4.2 dB |
| | 30 ~ 1000 MHz | ± 3.9 dB |
| | 1000 ~ 18000 MHz | ± 4.1 dB |
| | 18000 ~ 40000 MHz | ± 3.9 dB |
| RF Power, Conducted | Conducted Measuring | ± 0.5 dB |
| Occupied Bandwidth | Conducted Measuring | ± 2.4 % |
| Power Density | Conducted Measuring | ± 1.7 dB |
| Duty Cycle and Dwell Time | Conducted Measuring | ± 1.3 % |
| Conducted Unwanted Emission Strength | Conducted Measuring | ± 1.8 dB |
| DC Power Supply | -- | ± 3.2 % |
| Temperature | -- | ± 1.1 °C |
| Humidity | -- | ± 3.4 % |

Note: Please note that the measurement uncertainty are provided for informational purpose only and are not used in determining the Pass/Fail results.

1.10 List of Test Equipment

For Conducted measurements / W08-Conducted Measurement

| Equipment | Manufacturer | Model No. | Serial No. | Cal. Date | Due Date |
|--|--------------|------------|------------|------------|------------|
| ✓ Spectrum analyzer | Keysight | N9010A | MY54200737 | 2021/08/09 | 2022/08/08 |
| ✓ Wideband Peak Power Meter | Anritsu | ML2495A | 1733007 | 2021/09/07 | 2022/09/06 |
| ✓ Pulse Power Sensor + Precision Adaptor | Anritsu | MA2411B | 1726022 | 2021/09/07 | 2022/09/06 |
| Temperature Chamber | TAICHY | MHK-225LK | 1061121 | 2021/4/27 | 2022/4/26 |
| Wireless Connectivity Tester | R&S | CMW270 | 101307 | 2021/5/24 | 2022/5/23 |
| ✓ Attenuator | MVE | MVE2211-10 | CT-9-056 | 2021/08/18 | 2022/08/17 |
| Attenuator | MVE | MVE2211-20 | CT-9-057 | 2021/08/18 | 2022/08/17 |
| Attenuator | MVE | MVE2211-30 | CT-9-058 | 2021/08/18 | 2022/08/17 |
| Power Divider | MVE | MVE8546 | 170826003 | 2021/08/18 | 2022/08/17 |
| Power Splitter | MVE | MVE8547 | 170302047 | 2021/08/18 | 2022/08/17 |
| DC Power Supply | GW INSTEK | GPC-3060D | GER817636 | 2021/08/19 | 2022/08/18 |

Remark:

1. All equipments are calibrated every one year.
2. The test instruments marked with “✓” are used to measure the final test results.

For AC Conduction measurements / W08-CE

| | Equipment | Manufacturer | Model No. | Serial No. | Cal. Date | Due Date |
|---|---------------------------|----------------------------|---------------------------|------------|-----------|-----------|
| ✓ | EMI Test Receiver | R&S | ESR3 | 102309 | 2021/6/8 | 2022/6/7 |
| ✓ | 2-Line V-Network LISN | R&S | ENV216 | 101185 | 2021/6/11 | 2022/6/10 |
| ✓ | LISN | SCHWARZBECK | NSLK 8127RC | 05028 | 2021/6/11 | 2022/6/10 |
| ✓ | Transient Limiter | EM Electronics Corporation | EM-7600 | 857 | 2021/6/10 | 2022/6/9 |
| ✓ | 50ohm Cable | EMCI | EMCCFD300-BM-BM-5000 | 170612 | 2021/6/10 | 2022/6/9 |
| ✓ | 50 ohm terminal impedance | HUBER+SUHNER | 50 ohm terminal impedance | CT-1-109-1 | 2021/6/11 | 2022/6/10 |

Remark:

1. All equipments are calibrated every one year.
2. The test instruments marked with “✓” are used to measure the final test results.
3. Test Software version: FARAD EZ-EMC Ver.EMC-CON 3A1

For Radiated measurements / W08-996-2

| Equipment | Manufacturer | Model No. | Serial No. | Cal. Date | Due Date |
|------------------------------|--------------|---------------------|----------------------|------------|------------|
| ✓ Spectrum Analyzer | Keysight | N9010A | MY52220228 | 2021/08/20 | 2022/08/19 |
| ✓ EMI Receiver | Keysight | N9038A | MY51210173 | 2021/08/24 | 2022/08/23 |
| ✓ Loop Antenna | EMCI | LPA600 | 277 | 2021/09/02 | 2022/09/01 |
| ✓ TRILOG super broad Antenna | Schwarzbeck | VULB 9168 | VULB 9168-700 & 1421 | 2021/08/11 | 2022/08/10 |
| ✓ Horn Antenna | Schwarzbeck | BBHA 9120D | 01767 | 2021/08/11 | 2022/08/10 |
| ✓ Horn Antenna | Schwarzbeck | BBHA 9170 | 703 | 2020/12/03 | 2021/12/02 |
| ✓ Pre-Amplifier | EM | EMC330 | 060668 | 2021/08/24 | 2022/08/23 |
| ✓ Pre-Amplifier | EMEC | EM01G18G | 060648 | 2021/08/24 | 2022/08/23 |
| ✓ Pre-Amplifier | JPT | JPA0118-55-303K | 1910001800055003 | 2021/08/25 | 2022/08/24 |
| ✓ Pre-Amplifier | EMCI | EMC184045SE | 980515 | 2021/08/24 | 2022/08/23 |
| ✓ Cable | EMEC | EM-CB400 | 105060103 | 2021/08/24 | 2022/08/23 |
| ✓ Cable | EMEC | EM-CB400 | 105060102 | 2021/08/24 | 2022/08/23 |
| ✓ Cable | EMEC | EM-CB400 | 105060101 | 2021/08/24 | 2022/08/23 |
| ✓ RF Cable | HUBER+SUHNER | SF102 | MY2752/2 | 2021/08/24 | 2022/08/23 |
| ✓ RF Cable | EMCI | EMC104-SM-35M-15000 | 190645 | 2021/08/24 | 2022/08/23 |
| ✓ RF Cable | HUBER+SUHNER | SF102 | MY2751/2 | 2021/08/24 | 2022/08/23 |
| ✓ RF Cable | EMCI | EMC102-KM-KM-3000 | 170636 | 2021/08/24 | 2022/08/23 |
| ✓ RF Filter | EMEC | BRF-2400-2500 | 002 | 2021/08/26 | 2022/08/25 |
| RF Filter | EMEC | BRF-5150-5350 | 104 | 2021/08/26 | 2022/08/25 |
| RF Filter | EMEC | BRF-5470-5725 | 092 | 2021/08/26 | 2022/08/25 |
| RF Filter | EMEC | BRF-5725-5875 | 091 | 2021/08/26 | 2022/08/25 |
| ✓ RF Filter | EMEC | HPF-2800 | 002 | 2021/08/26 | 2022/08/25 |
| RF Filter | EMEC | HPF-5850 | 059 | 2021/08/26 | 2022/08/25 |
| SMA Notch Filter | MVE | MFN-902.928.S1 | 190604001 | 2021/09/02 | 2022/09/01 |

Remark:

1. All equipments are calibrated every one year.
2. The test instruments marked with “✓” are used to measure the final test results.
3. Test Software version: FARAD EZ-EMC Ver.WD-03A1-1

2 Test Result

2.1 Antenna Requirement

2.1.1 Applicable Standard

An intentional radiator shall be designed to ensure that no antenna other than that furnished by the responsible party shall be used with the device. The use of a permanently attached antenna or of an antenna that uses a unique coupling to the intentional radiator shall be considered sufficient to comply with the provisions of this section. The manufacturer may design the unit so that a broken antenna can be replaced by the user, but the use of a standard antenna jack or electrical connector is prohibited.

An intentional radiator shall be designed to ensure that no antenna other than as furnished by the responsible party shall be used with the device. If transmitting antennas of directional gain greater than 6dBi are using the power shall be reduced by the amount in dB that the directional gain of the antenna exceeds 6 dBi, for compliance to FCC 47CFR 15.247 (c) requirements.

2.1.2 Antenna Connected Construction

Non-standard antenna connector is used.

2.1.3 Antenna Gain

| No. | Manufacturer | Model No. | Antenna Type | Peak Gain |
|-----|-----------------------------------|-----------|--------------|---------------------|
| 1 | KINGRF TECHNOLOGY CO., LTD. | BS-1B | FPCB Antenna | 2.15 dBi for 2.4GHz |

2.2 Peak Output Power Measurement

2.2.1 Limit

For frequency hopping systems operating in the 2400-2483.5 MHz band employing at least 75 non-overlapping hopping channels, and all frequency hopping systems in the 5725-5850 MHz band: 1 watt. For all other frequency hopping systems in the 2400-2483.5 MHz band 0.125 watts.

2.2.2 Test Setup

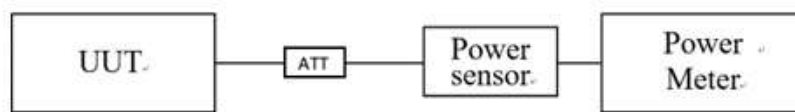

2.2.3 Test Procedure

1. Reference ANSI C63.10 : 2013 chapter 11.9.1.3
2. Enable the EUT transmit continuously.
3. Measure the conducted output power with cable loss and record the results in the test report.

2.2.4 Test Result

| Data Rate | Channel | Frequency (MHz) | Packet Type | Peak Power (dBm) | Power Limit (dBm) | Result |
|-----------------------------|---------|-----------------|-------------|------------------|-------------------|--------|
| 1 Mbps (GFSK) | 00 | 2402 | DH1 | 3.12 | ≤ 21 | Pass |
| | | | DH3 | 3.27 | ≤ 21 | Pass |
| | | | DH5 | 3.40 | ≤ 21 | Pass |
| | 39 | 2441 | DH1 | 5.96 | ≤ 21 | Pass |
| | | | DH3 | 6.09 | ≤ 21 | Pass |
| | | | DH5 | 6.21 | ≤ 21 | Pass |
| | 78 | 2480 | DH1 | 5.60 | ≤ 21 | Pass |
| | | | DH3 | 5.74 | ≤ 21 | Pass |
| | | | DH5 | 5.87 | ≤ 21 | Pass |
| 2 Mbps ($\pi/4$ -DQPSK) | 00 | 2402 | DH1 | 0.84 | ≤ 21 | Pass |
| | | | DH3 | 0.96 | ≤ 21 | Pass |
| | | | DH5 | 1.09 | ≤ 21 | Pass |
| | 39 | 2441 | DH1 | 3.98 | ≤ 21 | Pass |
| | | | DH3 | 4.13 | ≤ 21 | Pass |
| | | | DH5 | 4.26 | ≤ 21 | Pass |
| | 78 | 2480 | DH1 | 3.44 | ≤ 21 | Pass |
| | | | DH3 | 3.57 | ≤ 21 | Pass |
| | | | DH5 | 3.71 | ≤ 21 | Pass |
| 3 Mbps (8DPSK) | 00 | 2402 | DH1 | 1.22 | ≤ 21 | Pass |
| | | | DH3 | 1.35 | ≤ 21 | Pass |
| | | | DH5 | 1.47 | ≤ 21 | Pass |
| | 39 | 2441 | DH1 | 4.28 | ≤ 21 | Pass |
| | | | DH3 | 4.41 | ≤ 21 | Pass |
| | | | DH5 | 4.55 | ≤ 21 | Pass |
| | 78 | 2480 | DH1 | 3.78 | ≤ 21 | Pass |
| | | | DH3 | 3.92 | ≤ 21 | Pass |
| | | | DH5 | 4.06 | ≤ 21 | Pass |

Remark:

1. Peak Power = Reading value on power meter + cable loss
2. $10 \log(X/mW) = \text{dBm}$, $X=0.125$ watt (Limit)
 0.125 watt = 21 dBm

2.3 Number of Hopping Frequency

2.3.1 Limit

Frequency hopping systems operating in the 2400MHz-2483.5MHz bands shall use at least 15 hopping frequencies.

2.3.2 Test Setup

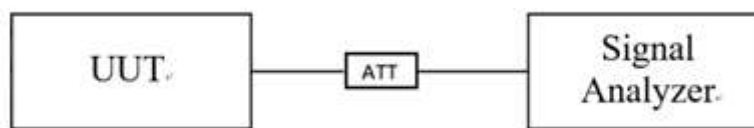

2.3.3 Test Procedure

1. Reference ANSI C63.10 : 2013 chapter 7.8.3
2. Enable the EUT transmit continuously.
3. Spectrum analyzer set:
 - a) Span = the frequency band of operation
 - b) RBW = (RBW to less than 30% of the channel spacing or the 20 dB bandwidth, whichever is smaller)
 - c) VBW \geq RBW
 - d) Sweep = auto
 - e) Detector function = peak
 - f) Trace = max hold.
4. The number of hopping frequency used is defined as the number of total channel.

2.3.4 Test Result

| Frequency (MHz) | Data Rate (Mbps) | Measurement (Hopping Channel) | Required Limit (Hopping Channel) | Result |
|-----------------|------------------|-------------------------------|----------------------------------|--------|
| 2402 ~ 2480 | 1 | 79 | ≥ 15 | Pass |
| 2402 ~ 2480 | 3 | 79 | ≥ 15 | Pass |



2.4 Hopping Channel Separation Measurement

2.4.1 Limit

Frequency hopping systems operating in the 2400-2483.5 MHz band may have hopping channel carrier frequencies that are separated by 25 kHz or two-thirds of the 20 dB bandwidth of the hopping channel, whichever is greater, provided the systems operate with an output power no greater than 125 mW.

2.4.2 Test Setup

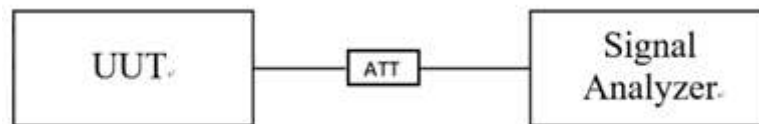

2.4.3 Test Procedure

1. Reference ANSI C63.10 : 2013 chapter 7.8.2
2. Enable the EUT transmit continuously.
2. Spectrum analyzer set:
 - a) Span = wide enough to capture the peaks of two adjacent channels
 - b) RBW set to approximately 30% of the channel spacing
 - c) VBW \geq RBW
 - d) Sweep = auto
 - e) Detector function = peak
 - f) Trace = max hold.

2.4.4 Test Result

| Channel | Frequency (MHz) | Data Rate (Mbps) | Measurement Level (MHz) | Limit of (2/3)*20dB (MHz) | Result |
|---------|-----------------|------------------|-------------------------|---------------------------|--------|
| 00 | 2402 | 1 | 1.002 | ≥ 0.613 | Pass |
| 39 | 2441 | 1 | 0.996 | ≥ 0.634 | Pass |
| 78 | 2480 | 1 | 0.996 | ≥ 0.651 | Pass |

Remark: 25kHz < two-thirds of the 20 dB bandwidth , whichever is two-thirds of the 20 dB bandwidth



| Channel | Frequency (MHz) | Data Rate (Mbps) | Measurement Level (MHz) | Limit of (2/3)*20dB (MHz) | Result |
|---------|-----------------|------------------|-------------------------|---------------------------|--------|
| 00 | 2402 | 3 | 1.002 | ≥ 0.884 | Pass |
| 39 | 2441 | 3 | 1.002 | ≥ 0.898 | Pass |
| 78 | 2480 | 3 | 1.002 | ≥ 0.893 | Pass |

Remark: 25kHz < two-thirds of the 20 dB bandwidth , whichever is two-thirds of the 20 dB bandwidth

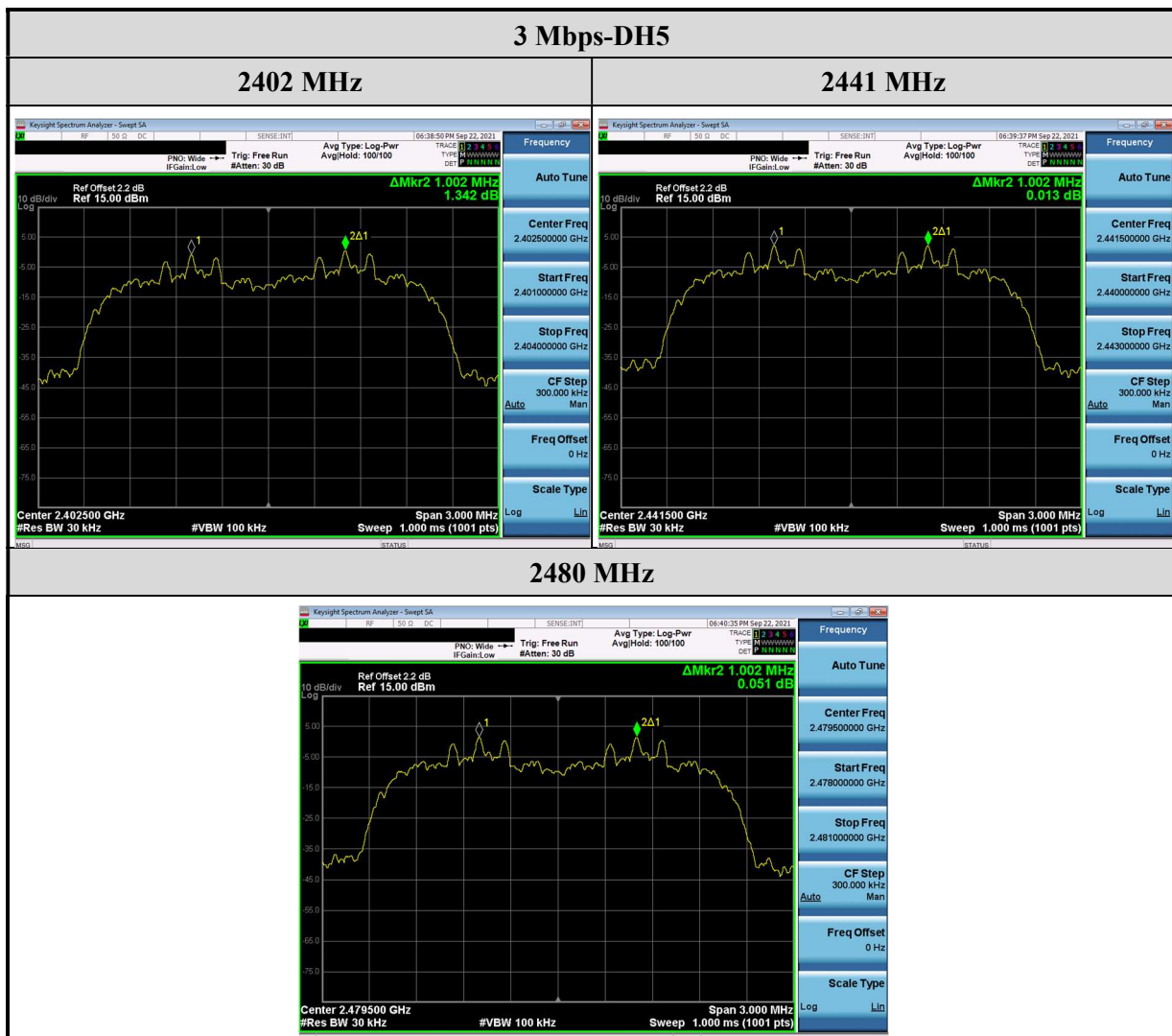

2.5 Dwell Time Measurement

2.5.1 Limit

The average time of occupancy on any channel shall not be greater than 0.4 seconds within a period of 0.4 seconds multiplied by the number of hopping channels employed.

2.5.2 Test Setup

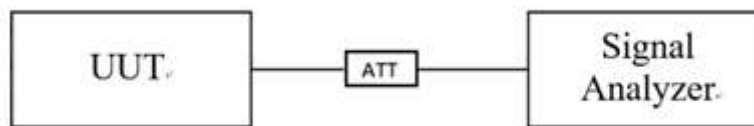

2.5.3 Test Procedure

1. Reference ANSI C63.10 : 2013 chapter 7.84
2. Enable the EUT transmit continuously.
3. Spectrum analyzer set:
 - a) Span = zero span, centered on a hopping channel
 - b) RBW should be set $\gg 1 / T$, where T is the expected dwell time per channel
 - c) VBW \geq RBW
 - d) Sweep = as necessary to capture the entire dwell time per hopping channel
 - e) Detector function = peak
 - f) Trace = max hold.

2.5.4 Test Result

| Data Rate (Mbps) | Data Packet | Pulse Duration (ms) | Number of hops during the actual observation period (in 3.16s) | Average time of occupancy (s) | Limit (s) | Result |
|------------------|-------------|---------------------|--|-------------------------------|-----------|--------|
| 1 | DH1 | 0.467 | 32 | 0.1494 | ≤ 0.4 | Pass |
| 1 | DH3 | 1.737 | 16 | 0.2780 | ≤ 0.4 | Pass |
| 1 | DH5 | 2.967 | 10 | 0.2967 | ≤ 0.4 | Pass |

Remark:

1. Number of frequency hopping = 79
2. Standard observation period = 31.6 s
3. Average time of occupancy = Pulse Duration × (Standard Observation period / Number of hops during the actual observation period (in 3.16s))

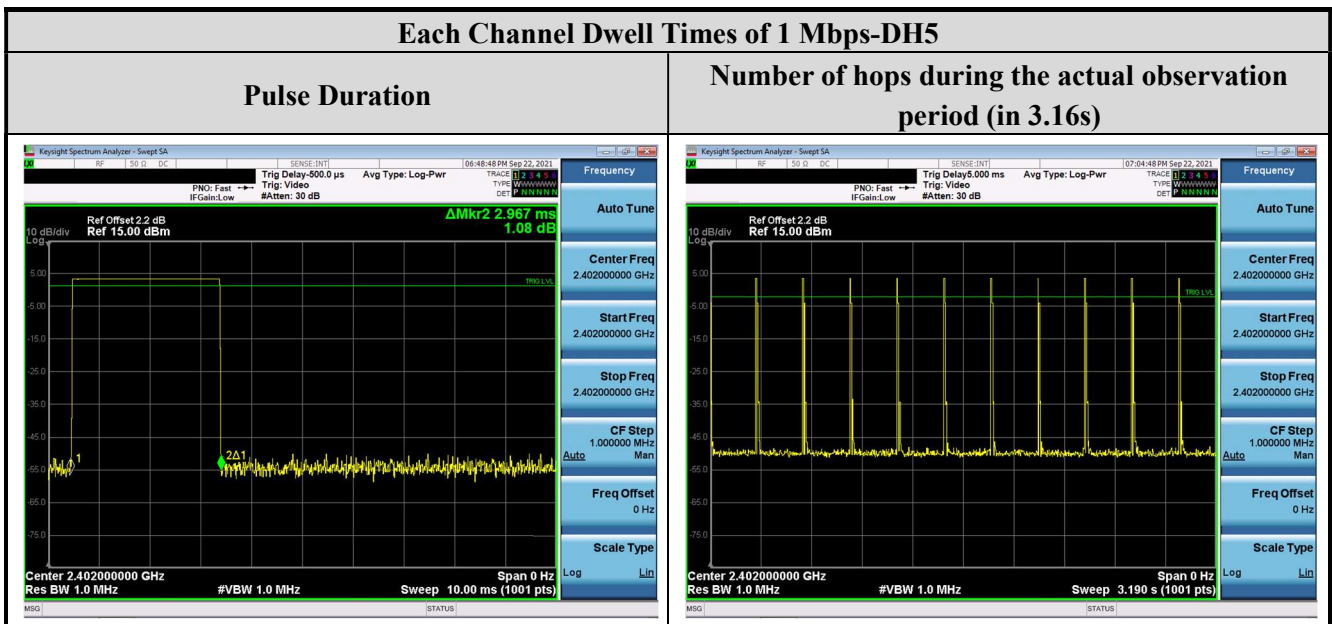

| Data Rate (Mbps) | Data Packet | Pulse Duration (ms) | Number of hops during the actual observation period (in 3.16s) | Average time of occupancy (s) | Limit (s) | Result |
|------------------|-------------|---------------------|--|-------------------------------|-----------|--------|
| 3 | DH1 | 0.457 | 32 | 0.1462 | ≤ 0.4 | Pass |
| 3 | DH3 | 1.727 | 16 | 0.2763 | ≤ 0.4 | Pass |
| 3 | DH5 | 2.977 | 11 | 0.3275 | ≤ 0.4 | Pass |

Remark:

1. Number of frequency hopping = 79
2. Standard observation period = 31.6 s
3. Average time of occupancy = Pulse Duration × (Standard Observation period / Number of hops during the actual observation period (in 3.16s))

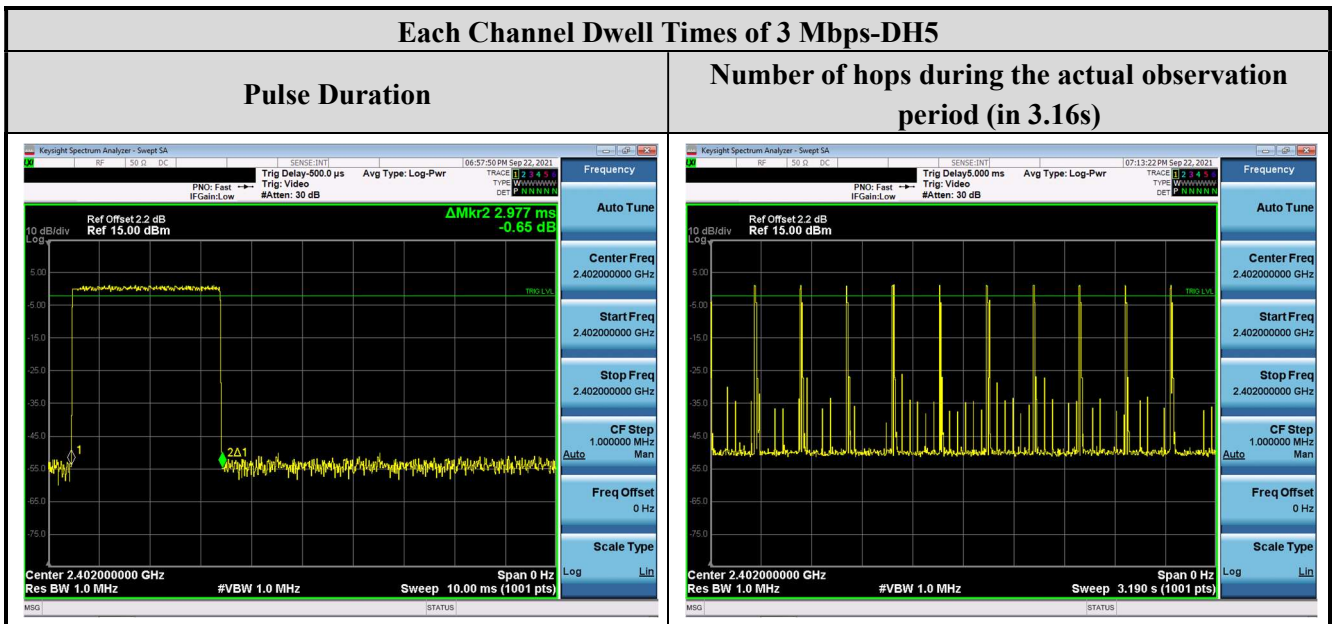

2.6 20dB Bandwidth Measurement

2.6.1 Limit

None.

2.6.2 Test Setup

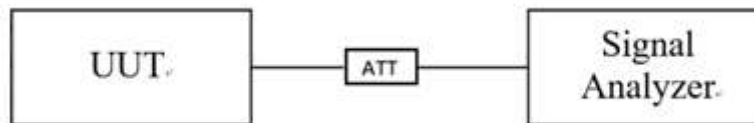

2.6.3 Test Procedure

1. Reference ANSI C63.10 : 2013 chapter 6.9
2. Enable the EUT transmit continuously.
3. Spectrum analyzer set:
 - a) approximately 2 to 5 times the 20 dB bandwidth, centered on a hopping channel
 - b) RBW shall be in the range of 1% to 5% of the OBW
 - c) VBW shall be approximately three times RBW
 - d) Sweep time = auto
 - e) Detector function = peak
 - f) Trace mode = max hold.

2.6.4 Test Result

| Channel | Frequency (MHz) | Data Rate (Mbps) | Measurement Level (MHz) | Required Limit (MHz) | Result |
|---------|-----------------|------------------|-------------------------|----------------------|--------|
| 00 | 2402 | 1 | 0.920 | None | N/A |
| 39 | 2441 | 1 | 0.951 | None | N/A |
| 78 | 2480 | 1 | 0.976 | None | N/A |



| Channel | Frequency (MHz) | Data Rate (Mbps) | Measurement Level (MHz) | Required Limit (MHz) | Result |
|---------|-----------------|------------------|-------------------------|----------------------|--------|
| 00 | 2402 | 3 | 1.326 | None | N/A |
| 39 | 2441 | 3 | 1.347 | None | N/A |
| 78 | 2480 | 3 | 1.339 | None | N/A |



2.7 Conducted Band Edges and Spurious Emission Measurement

2.7.1 Limit

In any 100 KHz bandwidth outside the frequency bands in which the spread spectrum intentional radiator is operating, the radio frequency power that is produced by the intentional radiator shall be at least 20dB below that in the 100KHz bandwidth within the band that contains the highest level of the desired power, In addition, radiated emissions which fall in the restricted bands, as defined in must also comply with the radiated emission limits. If the transmitter complies with the conducted power limits based on the use of RMS averaging over a time interval, the attenuation required under this paragraph shall be 30 dB instead of 20 dB

2.7.2 Test Setup

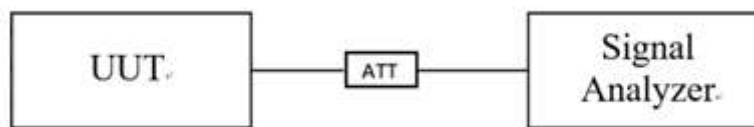

2.7.3 Test Procedure

1. Reference ANSI C63.10 : 2013 chapter 6.10
2. Enable the EUT transmit continuously.
3. Spectrum analyzer set :
 - a) RBW = 100 kHz
 - b) VBW = 300 kHz
 - c) Detector = peak
 - d) Sweep time = auto couple
 - e) Trace mode = max hold.

2.7.4 Test Result

1 Mbps-DH5

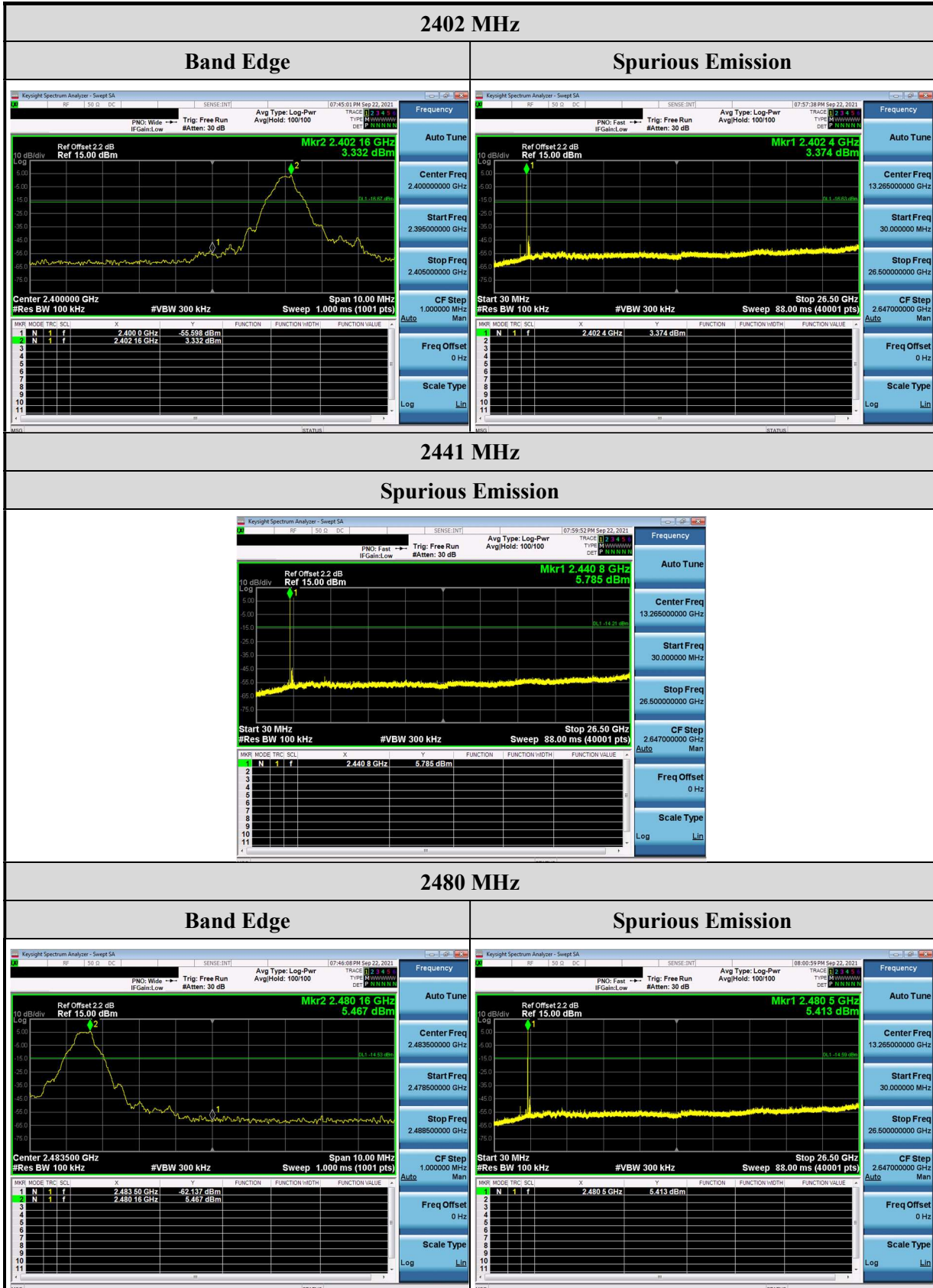

3 Mbps-DH5

2402 MHz

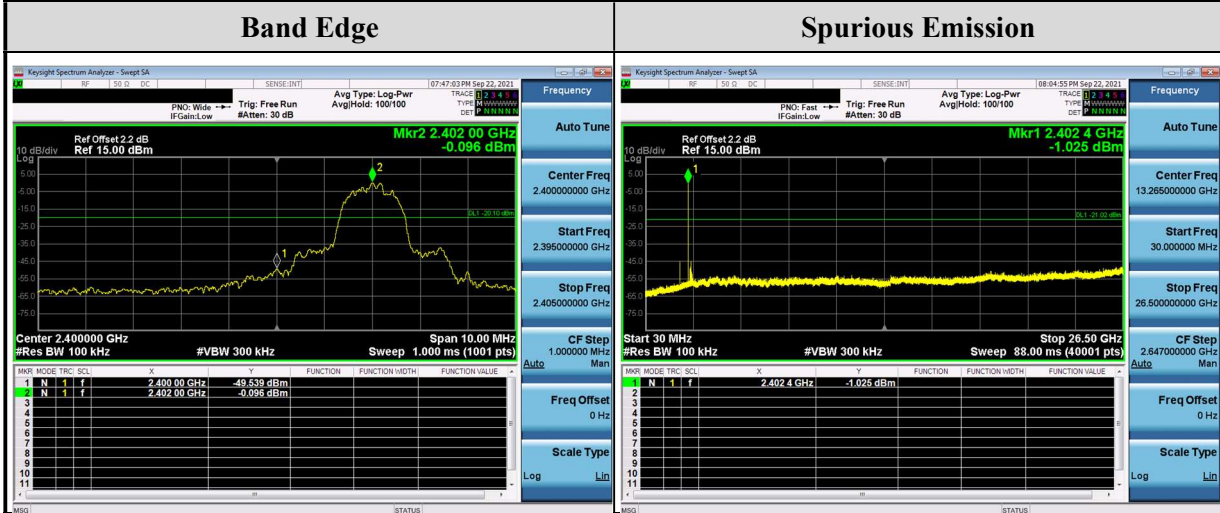

2441 MHz

Spurious Emission

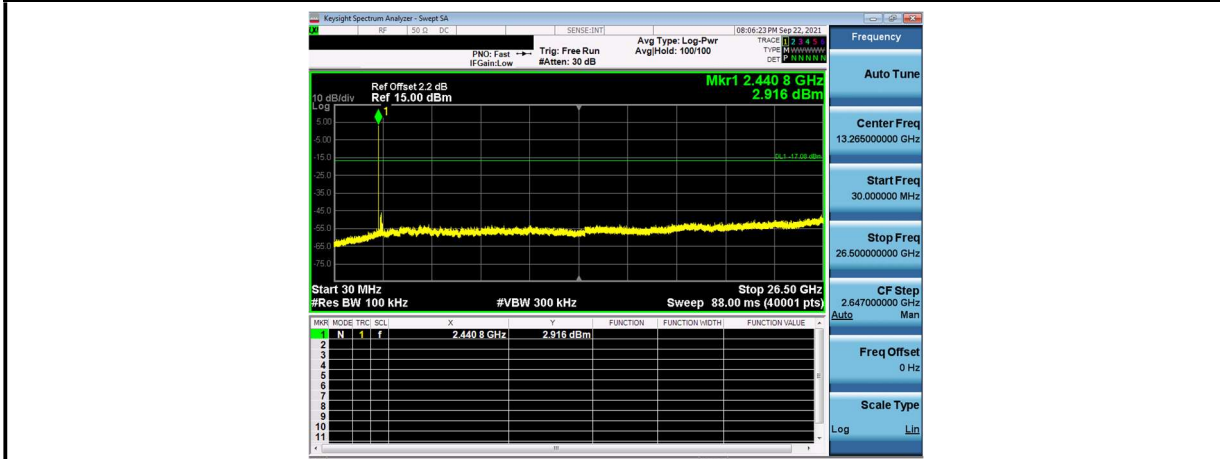

2480 MHz

| Band Edge | Spurious Emission |
|-----------|-------------------|
|-----------|-------------------|

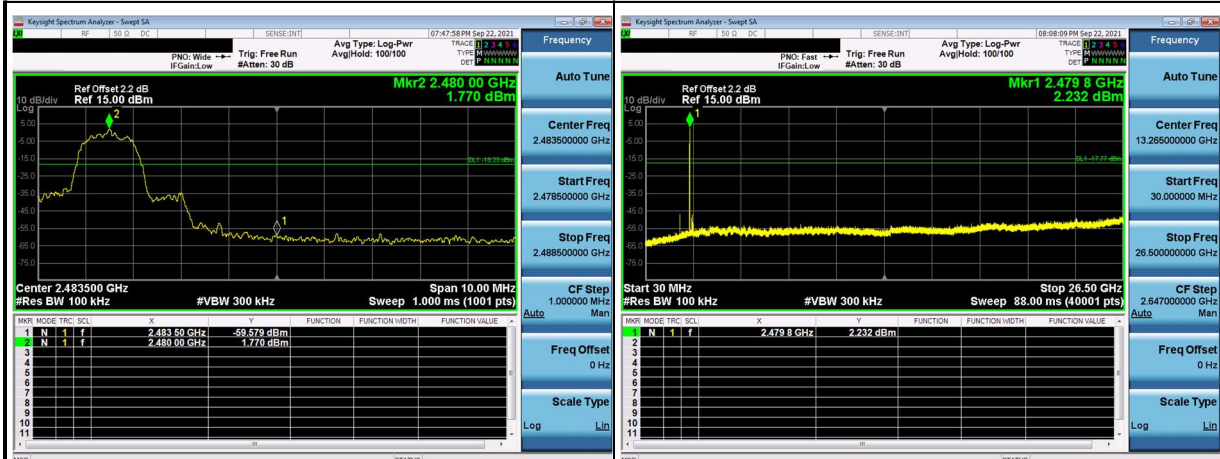

2.8 Radiated Band Edges and Spurious Emission Measurement

2.8.1 Limit

| Frequency (MHz) | Field Strength ($\mu\text{V/m}$) | Measurement Distance (m) |
|-----------------|------------------------------------|--------------------------|
| 0.009 – 0.490 | 2400/F(kHz) | 300 |
| 0.490 – 1.705 | 24000/F(kHz) | 30 |
| 1.705 – 30.0 | 30 | 30 |
| 30 – 88 | 100 | 3 |
| 88 – 216 | 150 | 3 |
| 216 - 960 | 200 | 3 |
| Above 960 | 500 | 3 |

Remarks:

1. RF Voltage (dBuV) = $20 \log$ RF Voltage(uV)
2. In the Above Table, the tighter limit applies at the band edges.
3. Distance refers to the distance in meters between the measuring instrument antenna and the closed point of any part of the device or system

2.8.2 Test Setup

Below 30MHz

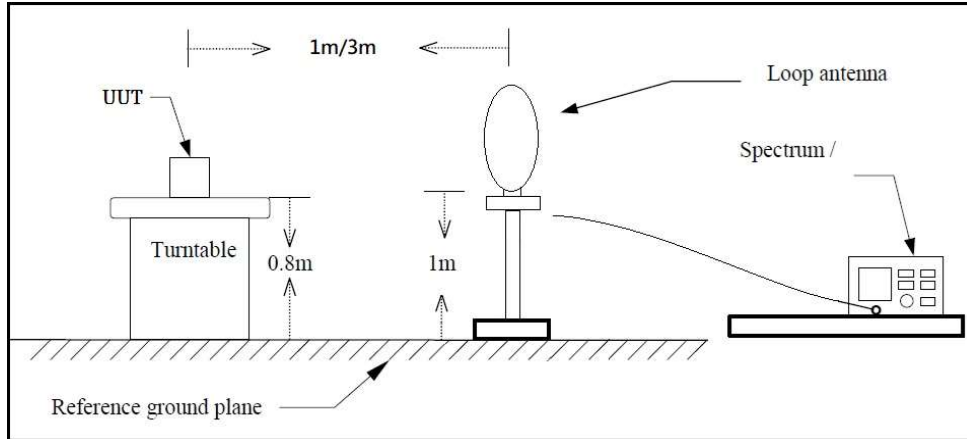

30MHz~1GHz

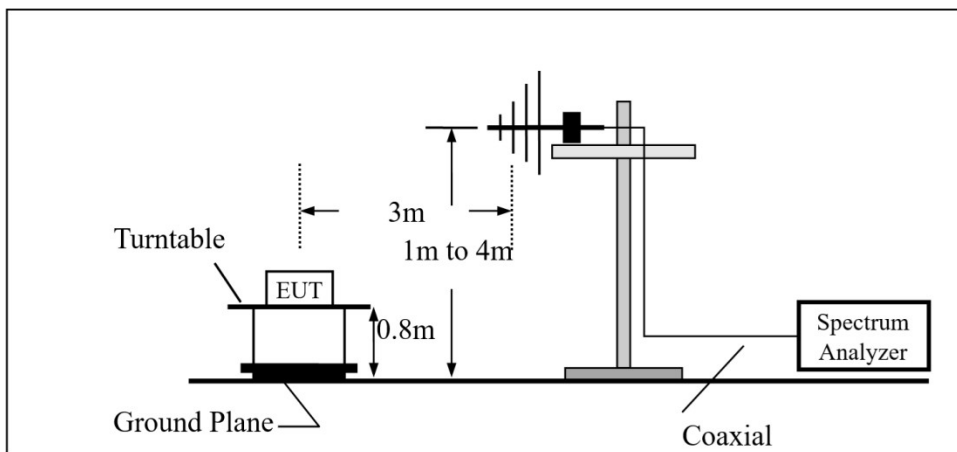

Above 1GHz

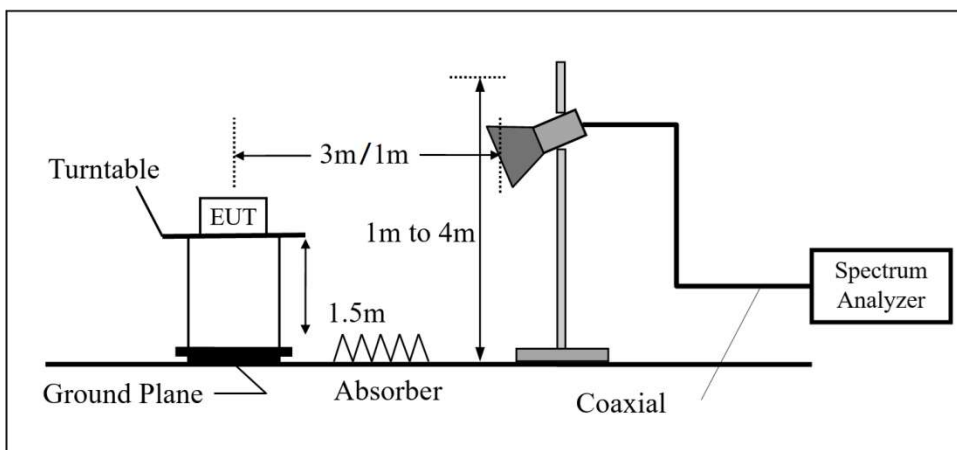

2.8.3 Test Procedure

The EUT was setup according to ANSI C63.10 : 2013 chapter 6.5, 6.6 and tested according test procedure of KDB 558074 for compliance to FCC 47CFR 15.247 requirements.

For Radiated emission below 30MHz

- (1) The EUT was placed on the top of a rotating table 0.8 meters above the ground in a 3 meter chamber room. The table was rotated 360 degrees to determine the position of the highest radiation.
- (2) The EUT was set 3 meters away from the interference-receiving antenna, which was mounted on the top of a variable-height antenna tower.
- (3) Parallel, perpendicular, and ground-parallel orientations of the antenna are set to make the measurement.
- (4) For each suspected emission, the EUT was arranged to its worst case and the rotatable table was turned from 0 degrees to 360 degrees to find the maximum reading.
- (5) The test-receiver system was set to Quasi-Peak Detect Function and Specified Bandwidth with Maximum Hold Mode.

For Radiated emission Above 30MHz

- (1) The EUT was placed on the top of a rotating table 0.8 meters (for below 1GHz) / 1.5 meters (for above 1GHz) above the ground at 3 meter chamber room for the test. The table was rotated 360 degrees to determine the position of the highest radiation.
- (2) The EUT was set 3 meters away from the interference-receiving antenna, the height of the antenna is varied from 1 meter to 4 meters above the ground to determine the maximum value of the field strength.
- (3) Parallel, perpendicular, and ground-parallel orientations of the antenna are set to make the measurement.
- (4) For each suspected emission, the EUT was arranged to its worst case and the rotatable table was turned from 0 degrees to 360 degrees to find the maximum reading.
- (5) The test-receiver system was set to quasi-peak detect function and specified bandwidth with maximum hold mode when the test frequency is below 1 GHz.
- (6) The test-receiver system was set to peak and average detect function and specified bandwidth with maximum hold mode when the test frequency is above 1 GHz. If the peak reading value also meets the average limit, measurement with the average detector is unnecessary.

2.8.4 Duty Cycle

| Mode | Data Rate (Mbps) | on time (ms) | on+off time (ms) | Duty cycle | Duty Factor (dB) | 1/T Minimum VBW (kHz) |
|------|------------------|--------------|------------------|------------|------------------|-----------------------|
| BT | 1 | 2.950 | 3.750 | 0.787 | 1.042 | 0.339 |
| | 3 | 2.960 | 3.750 | 0.789 | 1.027 | 0.338 |

2.8.5 Test Result of Radiated Band Edge Measurement

The following tables for radiated measurement, pre-scanned in three orthogonal panels, X, Y, Z. The worst cases (X axis) were recorded in this report.

| Test Frequency | |
|----------------|--------------------|
| RF | BT 1 Mbps / 3 Mbps |
| Tx | CH00 (2402 MHz) |
| | CH78 (2480 MHz) |

| | | | |
|-----------------------|-----------------------|----------------------------|------------|
| Test Mode : | Transmit BT-BR(1Mbps) | Test Date : | 2021/09/14 |
| Test Channel | CH00 (2402 MHz) | Temperature : | 24 °C |
| Polarization : | Horizontal | Relative Humidity : | 49 % |

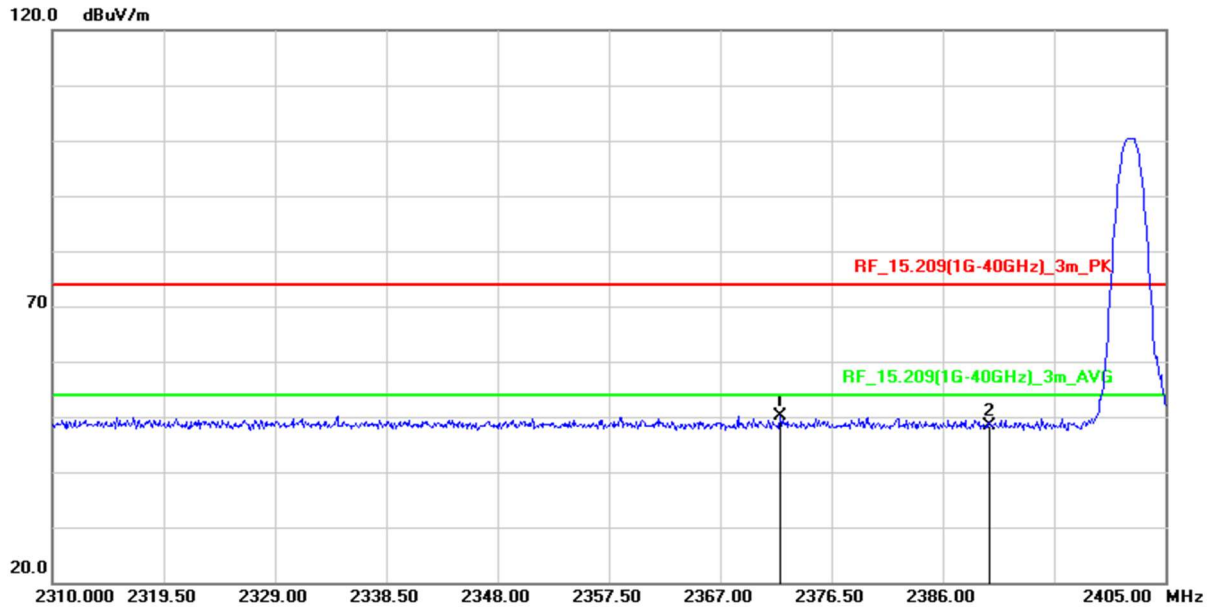

| No. | Frequency (MHz) | Reading (dBuV/m) | Correct Factor (dB/m) | Result (dBuV/m) | Limit (dBuV/m) | Margin (dB) | Remark |
|-----|-----------------|------------------|-----------------------|-----------------|----------------|-------------|--------|
| 1 | 2372.130 | 55.55 | -5.46 | 50.09 | 74.00 | -23.91 | peak |
| 2 | 2390.000 | 53.81 | -5.42 | 48.39 | 74.00 | -25.61 | peak |

Remark :

1. Correction Factor = Antenna factor + Cable loss – Amplifier gain
2. Result Value = Reading Level + Correct Factor
3. Margin Level = Result Value – Limit Value
4. The other emission levels were very low against the limit

| | | | |
|-----------------------|-----------------------|----------------------------|------------|
| Test Mode : | Transmit BT-BR(1Mbps) | Test Date : | 2021/09/14 |
| Test Channel | CH00 (2402 MHz) | Temperature : | 24 °C |
| Polarization : | Vertical | Relative Humidity : | 49 % |

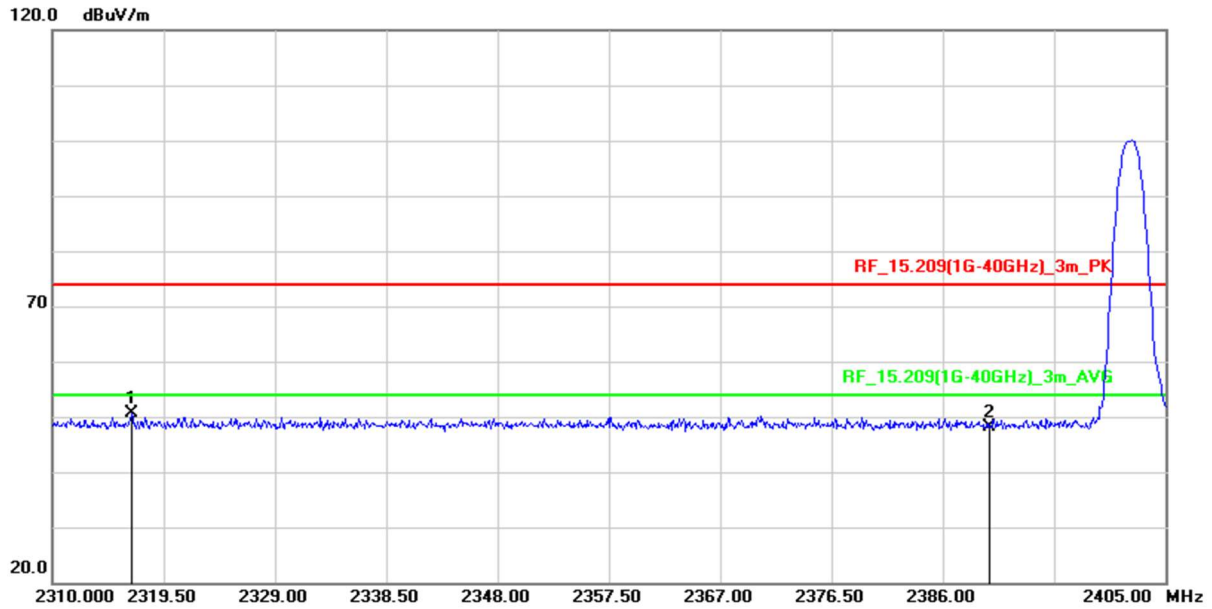

| No. | Frequency (MHz) | Reading (dBuV/m) | Correct Factor (dB/m) | Result (dBuV/m) | Limit (dBuV/m) | Margin (dB) | Remark |
|-----|-----------------|------------------|-----------------------|-----------------|----------------|-------------|--------|
| 1 | 2316.745 | 56.07 | -5.39 | 50.68 | 74.00 | -23.32 | peak |
| 2 | 2390.000 | 53.47 | -5.42 | 48.05 | 74.00 | -25.95 | peak |

Remark :

1. Correction Factor = Antenna factor + Cable loss – Amplifier gain
2. Result Value = Reading Level + Correct Factor
3. Margin Level = Result Value – Limit Value
4. The other emission levels were very low against the limit

| | | | |
|-----------------------|-----------------------|----------------------------|------------|
| Test Mode : | Transmit BT-BR(1Mbps) | Test Date : | 2021/09/14 |
| Test Channel | CH78 (2480 MHz) | Temperature : | 24 °C |
| Polarization : | Horizontal | Relative Humidity : | 49 % |

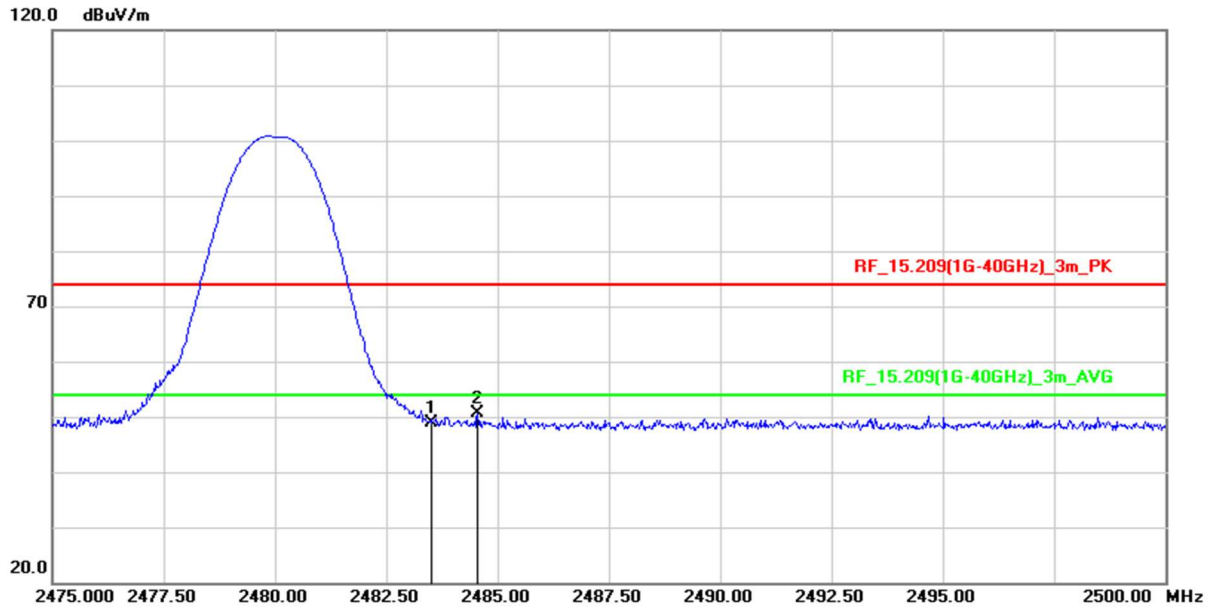

| No. | Frequency (MHz) | Reading (dBuV/m) | Correct Factor (dB/m) | Result (dBuV/m) | Limit (dBuV/m) | Margin (dB) | Remark |
|-----|-----------------|------------------|-----------------------|-----------------|----------------|-------------|--------|
| 1 | 2483.500 | 54.21 | -5.29 | 48.92 | 74.00 | -25.08 | peak |
| 2 | 2484.550 | 55.82 | -5.28 | 50.54 | 74.00 | -23.46 | peak |

Remark :

1. Correction Factor = Antenna factor + Cable loss – Amplifier gain
2. Result Value = Reading Level + Correct Factor
3. Margin Level = Result Value – Limit Value
4. The other emission levels were very low against the limit

| | | | |
|-----------------------|-----------------------|----------------------------|------------|
| Test Mode : | Transmit BT-BR(1Mbps) | Test Date : | 2021/09/14 |
| Test Channel | CH78 (2480 MHz) | Temperature : | 24 °C |
| Polarization : | Vertical | Relative Humidity : | 49 % |

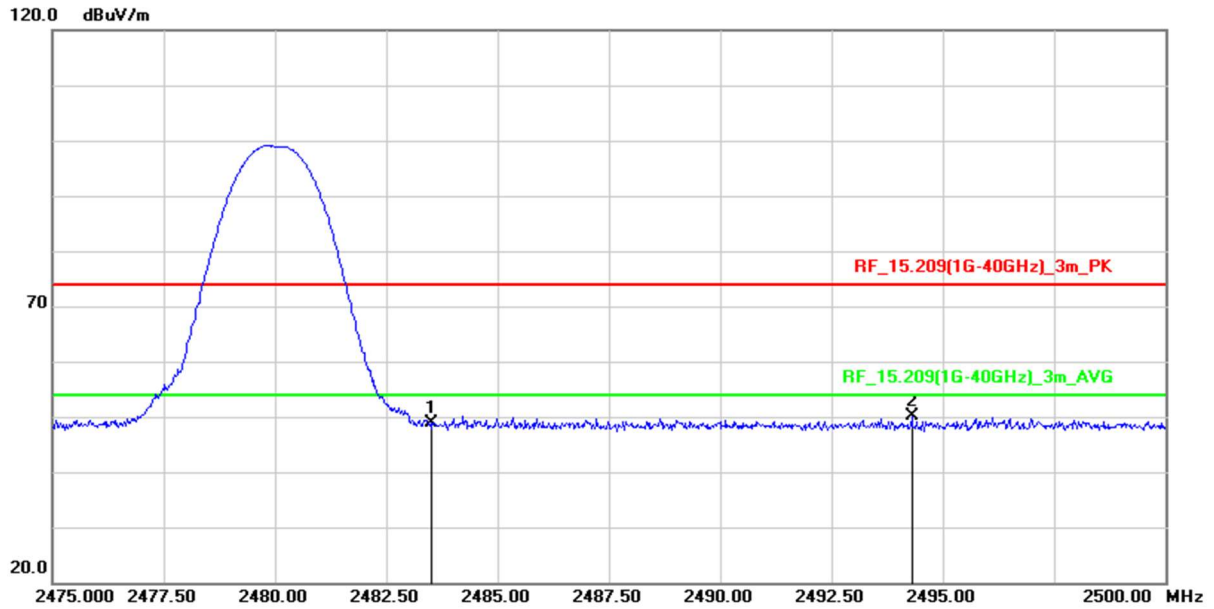

| No. | Frequency (MHz) | Reading (dBuV/m) | Correct Factor (dB/m) | Result (dBuV/m) | Limit (dBuV/m) | Margin (dB) | Remark |
|-----|-----------------|------------------|-----------------------|-----------------|----------------|-------------|--------|
| 1 | 2483.500 | 54.23 | -5.29 | 48.94 | 74.00 | -25.06 | peak |
| 2 | 2494.300 | 55.49 | -5.27 | 50.22 | 74.00 | -23.78 | peak |

Remark :

1. Correction Factor = Antenna factor + Cable loss – Amplifier gain
2. Result Value = Reading Level + Correct Factor
3. Margin Level = Result Value – Limit Value
4. The other emission levels were very low against the limit

| | | | |
|-----------------------|------------------------|----------------------------|------------|
| Test Mode : | Transmit BT-EDR(3Mbps) | Test Date : | 2021/09/14 |
| Test Channel | CH00 (2402 MHz) | Temperature : | 24 °C |
| Polarization : | Horizontal | Relative Humidity : | 49 % |

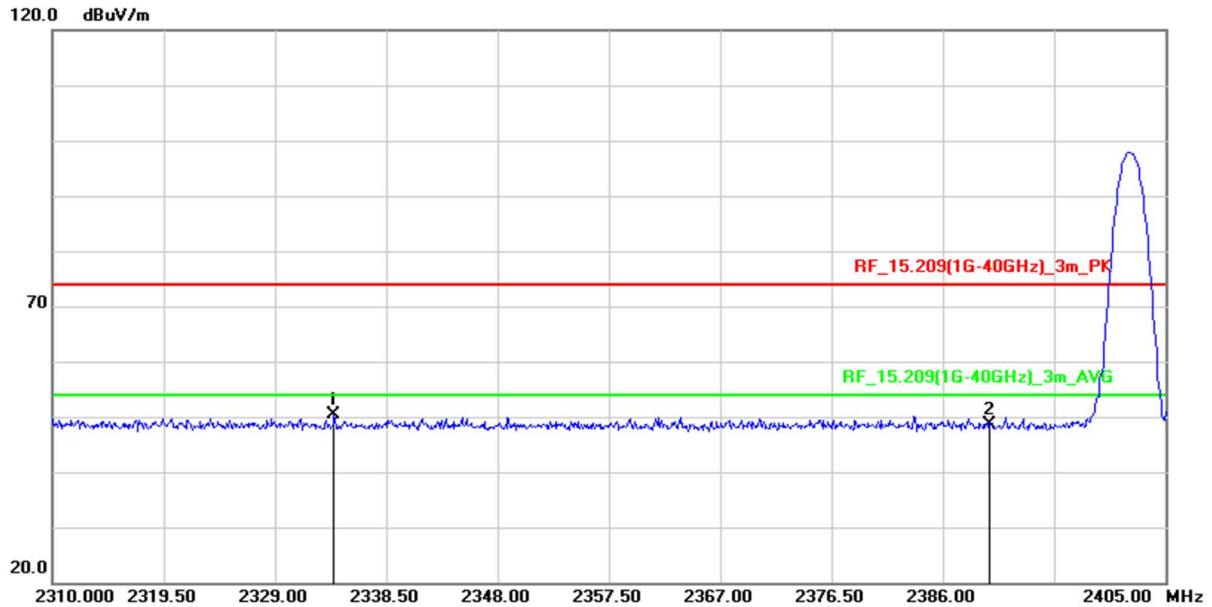

| No. | Frequency (MHz) | Reading (dBuV/m) | Correct Factor (dB/m) | Result (dBuV/m) | Limit (dBuV/m) | Margin (dB) | Remark |
|-----|-----------------|------------------|-----------------------|-----------------|----------------|-------------|--------|
| 1 | 2334.035 | 55.95 | -5.46 | 50.49 | 74.00 | -23.51 | peak |
| 2 | 2390.000 | 54.17 | -5.42 | 48.75 | 74.00 | -25.25 | peak |

Remark :

1. Correction Factor = Antenna factor + Cable loss – Amplifier gain
2. Result Value = Reading Level + Correct Factor
3. Margin Level = Result Value – Limit Value
4. The other emission levels were very low against the limit

| | | | |
|-----------------------|------------------------|----------------------------|------------|
| Test Mode : | Transmit BT-EDR(3Mbps) | Test Date : | 2021/09/14 |
| Test Channel | CH00 (2402 MHz) | Temperature : | 24 °C |
| Polarization : | Vertical | Relative Humidity : | 49 % |

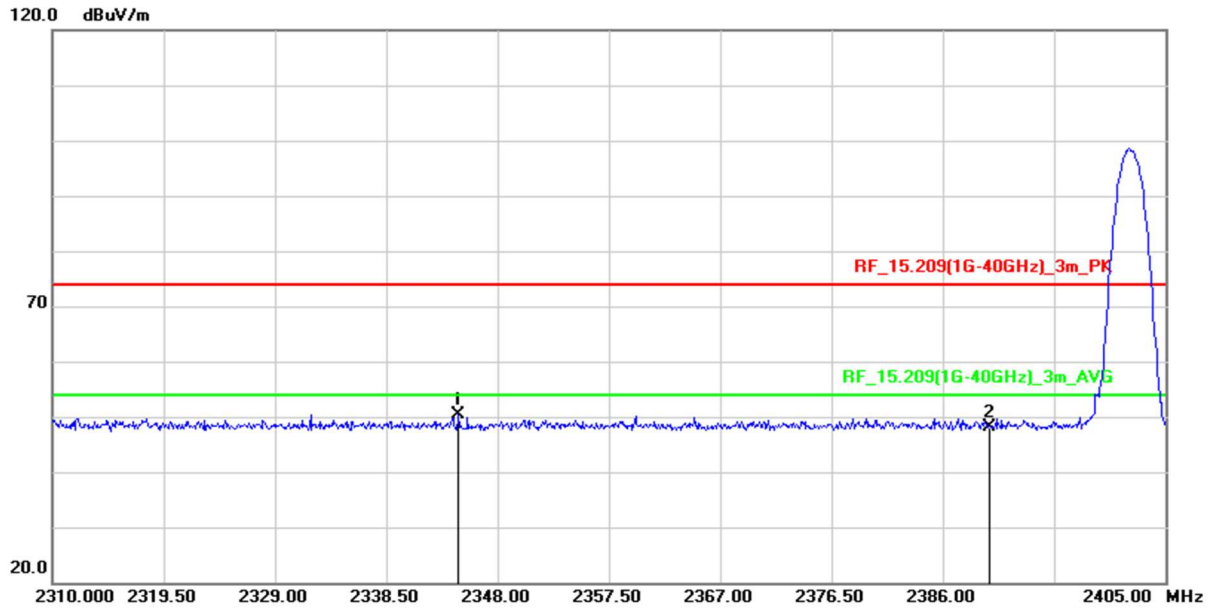

| No. | Frequency (MHz) | Reading (dBuV/m) | Correct Factor (dB/m) | Result (dBuV/m) | Limit (dBuV/m) | Margin (dB) | Remark |
|-----|-----------------|------------------|-----------------------|-----------------|----------------|-------------|--------|
| 1 | 2344.675 | 55.98 | -5.50 | 50.48 | 74.00 | -23.52 | peak |
| 2 | 2390.000 | 53.63 | -5.42 | 48.21 | 74.00 | -25.79 | peak |

Remark :

1. Correction Factor = Antenna factor + Cable loss – Amplifier gain
2. Result Value = Reading Level + Correct Factor
3. Margin Level = Result Value – Limit Value
4. The other emission levels were very low against the limit

| | | | |
|-----------------------|------------------------|----------------------------|------------|
| Test Mode : | Transmit BT-EDR(3Mbps) | Test Date : | 2021/09/14 |
| Test Channel | CH78 (2480 MHz) | Temperature : | 24 °C |
| Polarization : | Horizontal | Relative Humidity : | 49 % |

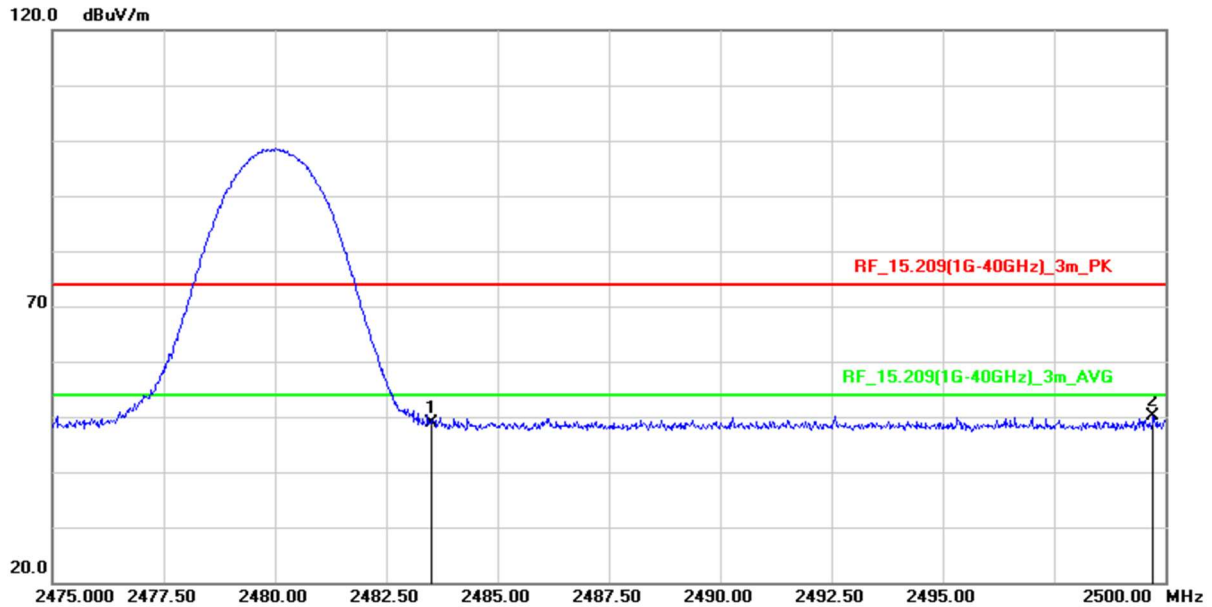

| No. | Frequency (MHz) | Reading (dBuV/m) | Correct Factor (dB/m) | Result (dBuV/m) | Limit (dBuV/m) | Margin (dB) | Remark |
|-----|-----------------|------------------|-----------------------|-----------------|----------------|-------------|--------|
| 1 | 2483.500 | 54.08 | -5.29 | 48.79 | 74.00 | -25.21 | peak |
| 2 | 2499.725 | 55.27 | -5.25 | 50.02 | 74.00 | -23.98 | peak |

Remark :

1. Correction Factor = Antenna factor + Cable loss – Amplifier gain
2. Result Value = Reading Level + Correct Factor
3. Margin Level = Result Value – Limit Value
4. The other emission levels were very low against the limit

| | | | |
|-----------------------|------------------------|----------------------------|------------|
| Test Mode : | Transmit BT-EDR(3Mbps) | Test Date : | 2021/09/14 |
| Test Channel | CH78 (2480 MHz) | Temperature : | 24 °C |
| Polarization : | Vertical | Relative Humidity : | 49 % |

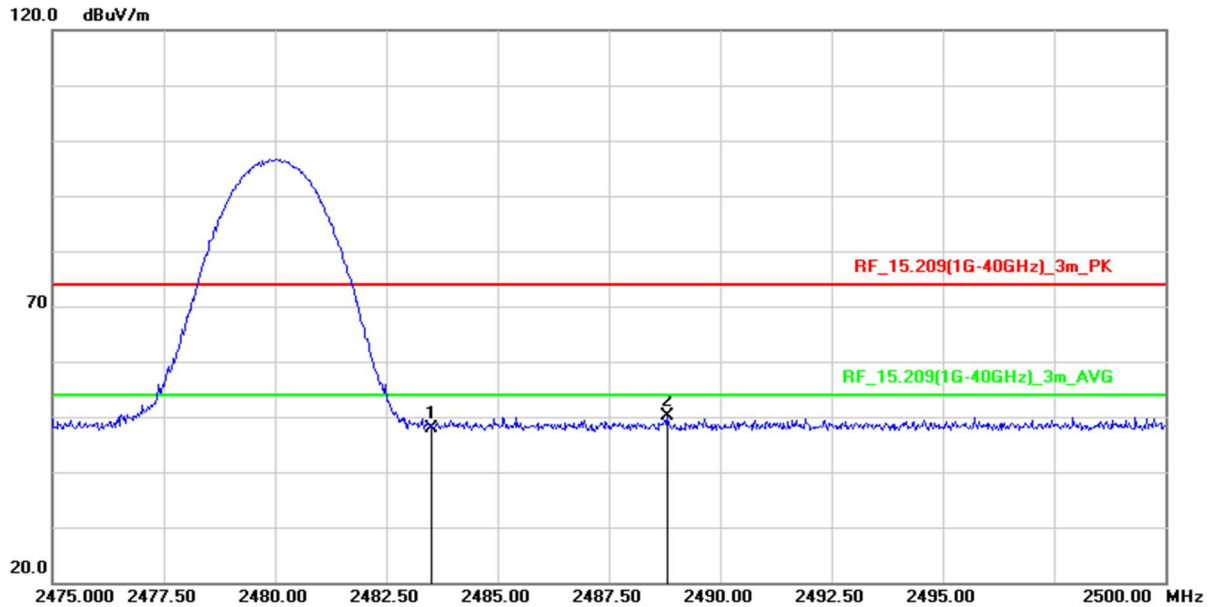

| No. | Frequency (MHz) | Reading (dBuV/m) | Correct Factor (dB/m) | Result (dBuV/m) | Limit (dBuV/m) | Margin (dB) | Remark |
|-----|-----------------|------------------|-----------------------|-----------------|----------------|-------------|--------|
| 1 | 2483.500 | 53.11 | -5.29 | 47.82 | 74.00 | -26.18 | peak |
| 2 | 2488.800 | 55.37 | -5.28 | 50.09 | 74.00 | -23.91 | peak |

Remark :

1. Correction Factor = Antenna factor + Cable loss – Amplifier gain
2. Result Value = Reading Level + Correct Factor
3. Margin Level = Result Value – Limit Value
4. The other emission levels were very low against the limit

2.8.6 Test Result of Radiated Spurious Emission Measurement

- (1) The radiation measurement frequency is 9kHz ~ 30MHz. The interference value of this frequency range is less than the limit value of 20 dB. It is considered that the background noise value is not recorded.
- (2) The following table shows the radiation measurement frequency from 30MHz to 26.5GHz, pre-scanning in the X, Y and Z axes. The worst case (X-axis) is documented in this report.

| Test Frequency | |
|----------------|--------------------|
| RF | BT 1 Mbps / 3 Mbps |
| Tx | CH00 (2402 MHz) |
| | CH39 (2441 MHz) |
| | CH78 (2480 MHz) |