

USER MANUAL

VERSION 2.0 August 2024

Panel PC Hardware System

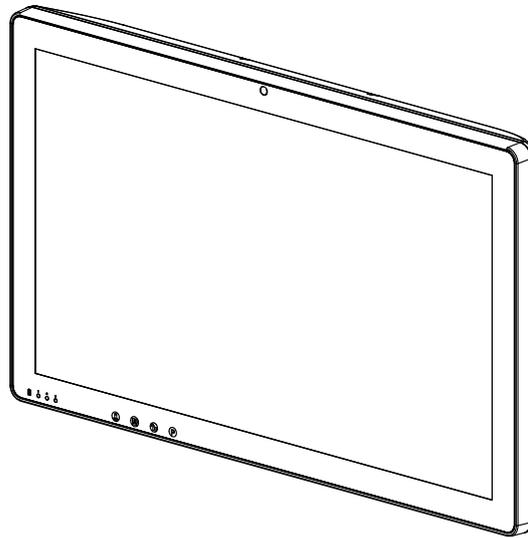

The information contained in this document is subject to change without notice. We make no warranty of any kind with regard to this material, including, but not limited to, the implied warranties of merchantability and fitness for a particular purpose. We shall not be liable for errors contained herein or for incidental or consequential damages in connection with the furnishing, performance, or use of this material. This document contains proprietary information that is protected by copyright. All rights are reserved. No part of this document may be photocopied, reproduced or translated to another language without the prior written consent of the manufacturer.

TRADEMARK

Intel®, Pentium® and MMX are registered trademarks of Intel® Corporation. Microsoft® and Windows® are registered trademarks of Microsoft Corporation. Other trademarks mentioned herein are the property of their respective owners.

Safety

IMPORTANT SAFETY INSTRUCTIONS

1. To disconnect the machine from the electrical power supply, turn off the power switch and remove the power cord plug from the wall socket. The wall socket must be easily accessible and in close proximity to the machine.
2. Read these instructions carefully. Save these instructions for future reference.
3. Follow all warnings and instructions marked on the product.
4. Do not use this product near water.
5. Do not place this product on an unstable cart, stand, or table. The product may fall, causing serious damage to the product.
6. Slots and openings in the cabinet and the back or bottom are provided for ventilation to ensure reliable operation of the product and to protect it from overheating. These openings must not be blocked or covered. The openings should never be blocked by placing the product on a bed, sofa, rug, or other similar surface. This product should never be placed near or over a radiator or heat register or in a built-in installation unless proper ventilation is provided.
7. This product should be operated from the type of power indicated on the marking label. If you are not sure of the type of power available, consult your dealer or local power company.
8. Do not allow anything to rest on the power cord. Do not locate this product where persons will walk on the cord.
9. Never push objects of any kind into this product through cabinet slots as they may touch dangerous voltage points or short out parts that could result in a fire or electric shock. Never spill liquid of any kind on the product.
10. To avoid the risk of electric shock, this equipment must only be connected to a supply mains with protective earth.
11. No modification of this equipment is allowed.
12. Power supply is specified as part of medical equipment.

13. The medical PC can be cleaned in accordance with normal clinical cleaning practices, including wiping with water or medical grade wipes, provided no substance containing acids or cleaning alkali liquids is used.
14. Medical grade wipes must not contain more than 80% alcohol content measured against the total content of the wipe.
15. Operator shall not contact patient simultaneously when in use with the medical computer.

Sécurité

INSTRUCTIONS IMPORTANTES RELATIVES À LA SECURITE

1. Pour débrancher la machine de l'alimentation électrique, éteignez l'interrupteur d'alimentation et retirez le cordon d'alimentation de la prise murale. La prise murale doit être facilement accessible et à proximité de la machine.
2. Lisez attentivement ces instructions. Conservez ces instructions pour une référence future.
3. Suivez tous les avertissements et les instructions indiquées sur le produit.
4. Ne pas utiliser ce produit à proximité de l'eau.
5. Ne pas placer ce produit sur un chariot, un support ou une table. Le produit peut tomber, causant de graves dommages à l'appareil.
6. Les fentes et les ouvertures dans le boîtier, l'arrière ou le fond sont prévues pour la ventilation afin d'assurer un fonctionnement fiable du produit et le protéger de la surchauffe. Ces ouvertures ne doivent pas être obstruées ou couvertes. Les ouvertures ne doivent jamais être bloquées en plaçant l'appareil sur un lit, un canapé, un tapis ou autre surface similaire. Ce produit ne doit jamais être placé : à proximité ou sur un radiateur, sur un registre de chaleur ou dans une installation intégrée à moins qu'une ventilation adéquate soit prévue.
7. Ce produit doit être utilisé avec le type d'alimentation indiqué sur l'étiquette. Si vous n'êtes pas sûr du type d'alimentation disponible, consultez votre revendeur ou représentant local de l'entreprise.
8. Ne laissez rien reposer sur le cordon d'alimentation. Ne placez pas ce produit là où des personnes peuvent marcher sur le cordon.
9. N'introduisez jamais d'objets d'aucune sorte dans ce produit à travers les fentes du coffret car ils pourraient entrer en contact avec des points sous tension dangereux ou court-circuiter des pièces. Ne renversez jamais de liquide d'aucune sorte sur le produit.
10. Pour éviter tout risque de choc électrique, cet équipement ne doit être branché que sur une prise secteur avec terre.
11. Aucune modification de cet équipement n'est autorisée.
12. L'alimentation est spécifiée comme faisant partie du matériel médical.
13. L'ordinateur médical peut être nettoyé conformément aux pratiques de nettoyage cliniques habituelles, notamment en essuyant avec de l'eau ou des lingettes de qualité médicale, à condition qu'aucune substance contenant des acides ou des liquides de nettoyage alcalins ne soient utilisés.
14. Les lingettes de qualité médicale ne doivent pas contenir plus de 80% d'alcool par rapport au contenu total de la lingette.
15. L'opérateur ne doit pas toucher le patient lorsqu'il utilise l'ordinateur médical.



This device complies with the requirements of the EEC directive 2014/30/EU with regard to “Electromagnetic compatibility” and 2014/35/EU “Low Voltage Directive”.



This device complies with part 15 of the FCC rules. Operation is subject to the following two conditions:

- (1) This device may not cause harmful interference.
- (2) This device must accept any interference received, including interference that may cause undesired operation.

CAUTION ON LITHIUM BATTERIES

There is a danger of explosion if the battery is replaced incorrectly. Replace only with the same or equivalent type recommended by the manufacturer. Discard used batteries according to the manufacturer’s instructions.



Battery Caution

Risk of explosion if battery is replaced by an incorrectly type. Dispose of used battery according to the local disposal instructions.



Safety Caution

Note: To comply with IEC60950-1 Clause 2.5 (limited power sources, L.P.S) related legislation, peripherals shall be 4.7.3.2 “Materials for fire enclosure” compliant.

4.7.3.2 Materials for fire enclosures

For MOVABLE EQUIPMENT having a total mass not exceeding 18kg.the material of a FIRE ENCLOSURE, in the thinnest significant wall thickness used, shall be of V-1 CLASS MATERIAL or shall pass the test of Clause A.2.

For MOVABLE EQUIPMENT having a total mass exceeding 18kg and for all STATIONARY EQUIPMENT, the material of a FIRE ENCLOSURE, in the thinnest significant wall thickness used, shall be of 5VB CLASS MATERIAL or shall pass the test of Clause A.1

AVERTISSEMENT SUR LES BATTERIES AU LITHIUM

Il y a un danger d’explosion si la batterie n’est pas remplacée correctement. Remplacez-la uniquement par une batterie identique ou de type équivalent recommandée par le fabricant.les batteries usagées doivent être mises au rebut conformément aux instructions du fabricant.



Avertissement Batterie

Risque d'explosion si la batterie est remplacée par un élément incompatible. Jetez les batteries usagées selon les instructions des dispositions locales .



Avertissement de sécurité

Remarque: Pour répondre à la norme IEC60950-1 alinéa 2.5 (sources d'énergie limitées, LPS) liés la législation, les périphériques doivent être conforme 4.7.3.2 «Matériaux pour enceinte coupe-feu»

4.7.3.2 «Matériaux pour équipements coupe-feu»

Pour les équipements mobiles ayant une masse totale n'excédant pas 18kg :

Les matériaux d'un équipement coupe-feu, dans l'épaisseur de paroi retenue la plus significativement mince, doivent être des matériels de CLASSE V-1 ou doivent passer le test de l'article A.2.

Pour équipements mobiles ayant une masse totale supérieure à 18 kg et pour tous les équipements FIXES :

Les matériaux d'un équipement coupe-feu dans l'épaisseur de paroi retenue la plus significativement mince, doivent être des matériels de CLASSE V-1, doivent être de classe Matériel 5VB ou doivent passer le test de l'article A.1

LEGISLATION AND WEEE SYMBOL

2012/19/EU Waste Electrical and Electronic Equipment Directive on the treatment, collection, recycling and disposal of electric and electronic devices and their components.

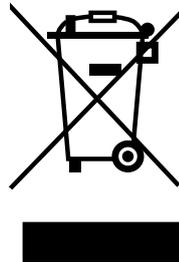

The crossed dust bin symbol on the device means that it should not be disposed of with other household wastes at the end of its working life. Instead, the device should be taken to the waste collection centers for activation of the treatment, collection, recycling and disposal procedure.

To prevent possible harm to the environment or human health from uncontrolled waste disposal, please separate this from other types of wastes and recycle it responsibly to promote the sustainable reuse of material resources.

Household users should contact either the retailer where they purchased this product, or their local government office, for details of where and how they can take this item for environmentally safe recycling.

Business users should contact their supplier and check the terms and conditions of the purchase contract.

This product should not be mixed with other commercial wastes for disposal.

Troubleshooting

For your own safety and that of your equipment, always take the following precautions. Disconnect the power plug (by pulling the plug, not the cord), from your computer if any of the following conditions exists:

- The power cord or plug becomes frayed or otherwise damaged.
- You spill something into the system.
- Your computer has been dropped or damaged.
- You suspect that your computer needs service or repair.
- You want to clean the computer or screen.
- You want to remove/install any parts.

Repair of the device may only be carried out by the manufacture. We recommend that a service contract be obtained with supplier and that all repairs also be carried out by them. Otherwise the correct functioning of the device may be compromised.

Revision History

Changes to the original user manual are listed below:

Revision	Description	Date
2.0	• Initial release	August 2024

Table of Contents

1. Intended Use.....	1
2. Packing List.....	2
2-1. Standard Items.....	2
2-2. Optional Items.....	2
3. System View.....	3
3-1. Front & Side View.....	3
3-2. Rear & Bottom View.....	4
3-3. I/O View.....	4
3-4. Dimension.....	5
4. Basic Operation.....	6
4-1. Powering ON & OFF.....	6
4-2. Charging the Battery.....	7
4-3. Battery Level Indication.....	8
4-4. Battery Discharging Mode Flowchart.....	9
5. System Assembly.....	10
5-1. Opening the Cable Cover.....	10
5-2. Replacing the Battery.....	10
5-3. Replacing the M.2 SSD Card.....	11

6. Specification.....	12
7. Configuration.....	14
7-1. F87U Motherboard Layout.....	14
7-2. Connectors & Functions	15
7-3. Jumper Setting	16

1. Intended Use

The Medical Computer is a computing device capable of storing, retrieving and sending data electronically. This Medical Computer, including its user interface, RTC battery, PCB and power supply, is intended to be fixed to a VESA wall mount in medical care environment. This Medical Computer Hardware System must be operated by professional personnel (i.e., doctor, nurse...).

Application: Access to patient records / Hospital administration system / Bed management.

Cleaning method

- Turn off the system and disconnect the power cord and remove batteries before cleaning the system.
- Use non-alcohol and non-abrasive liquid to clean the touch screen.
- Spread the cleaning liquid onto a sponge or cloth and then wipe the touch screen gently.

2. Packing List

2-1. Standard Items

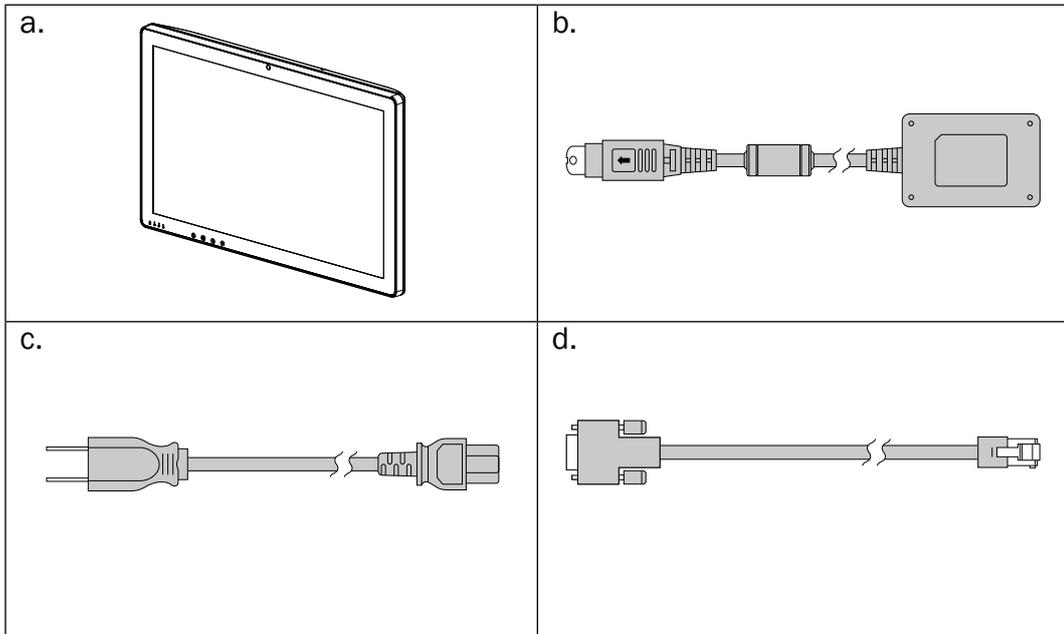

- a. System
- b. Power adapter
- c. Power cord
- d. RJ45-DB9 cable (x2)

Note: Power cord will be supplied differently according to various region or country.

2-2. Optional Items

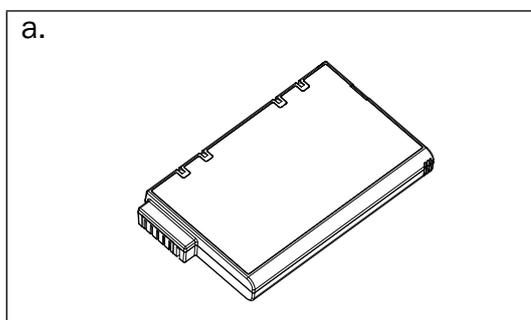

- a. Battery

3. System View

3-1. Front & Side View

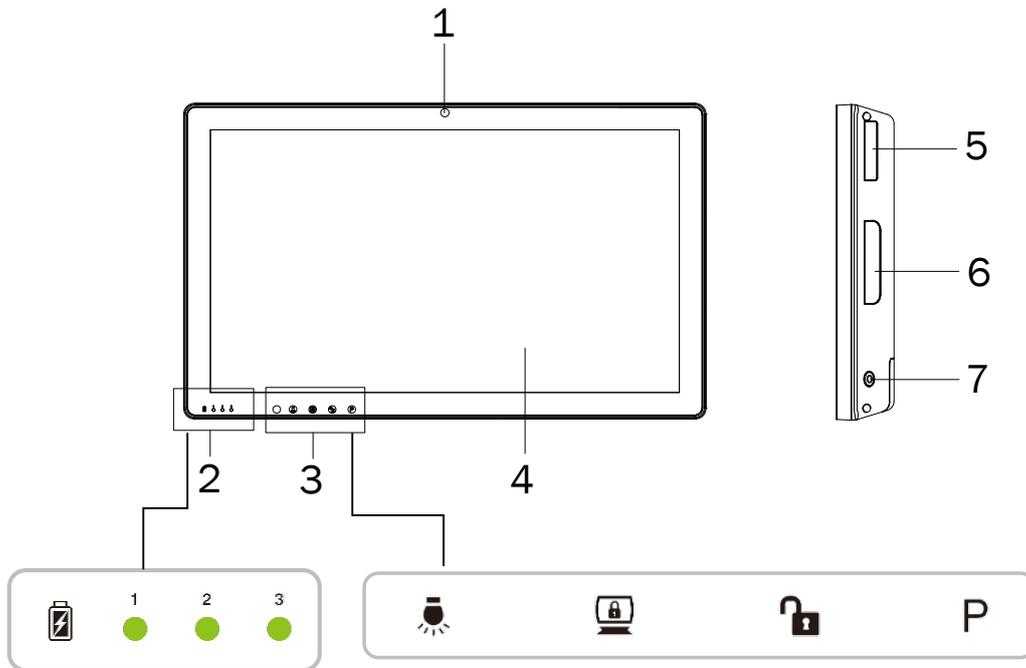

Item No.	Description
1	5M front camera (option)
2	batteries status
3	capacitive sensor touch function keys (from left to right: LED reading light /touch screen lock key /touch screen unlock key /programmable function key)
4	21.5" true flat PCAP multi-touch
5	Dummy cover of RFID & IC card reader
6	Dummy cover of MSR module
7	Power button

3-2. Rear & Bottom View

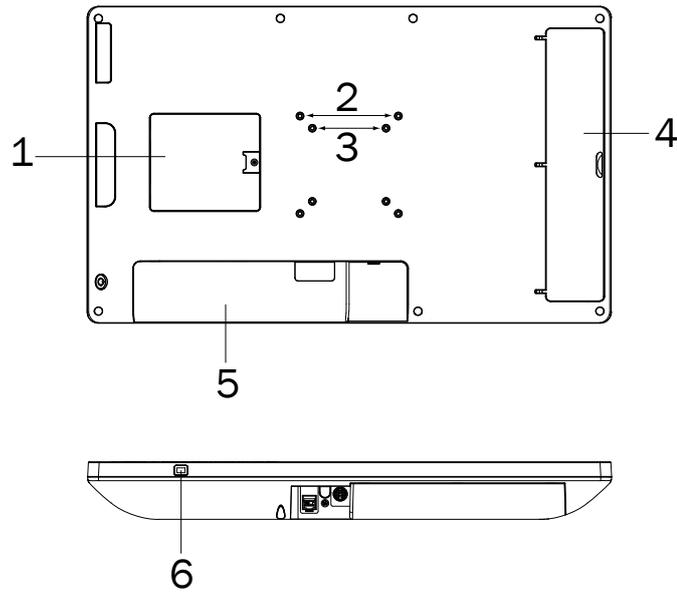

Item No.	Description
1	M.2 SSD card door
2	100 x 100 VESA mounting holes
3	75 x 75 VESA mounting holes
4	Battery door
5	Cable cover
6	LED reading light

3-3. I/O View

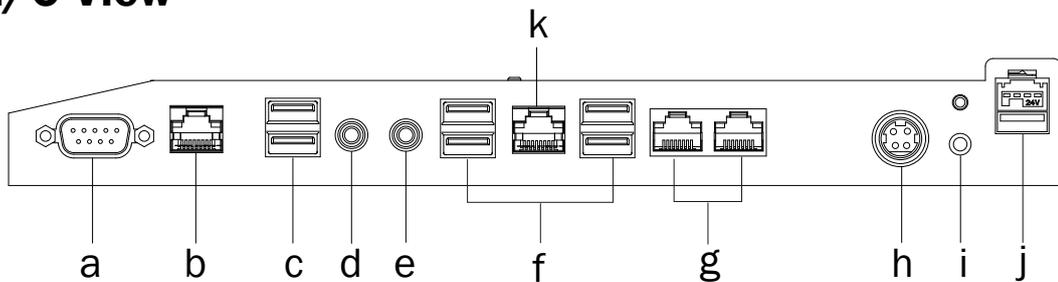

Item No.	Description
a	COM3
b	2 nd LAN
c	USB 2.0 (x2)
d	Mic in
e	Line out
f	USB 3.0 (x4)
g	COM1~COM2
h	DC in
i	Power button
j	Powered USB 24V
k	LAN

3-4. Dimension

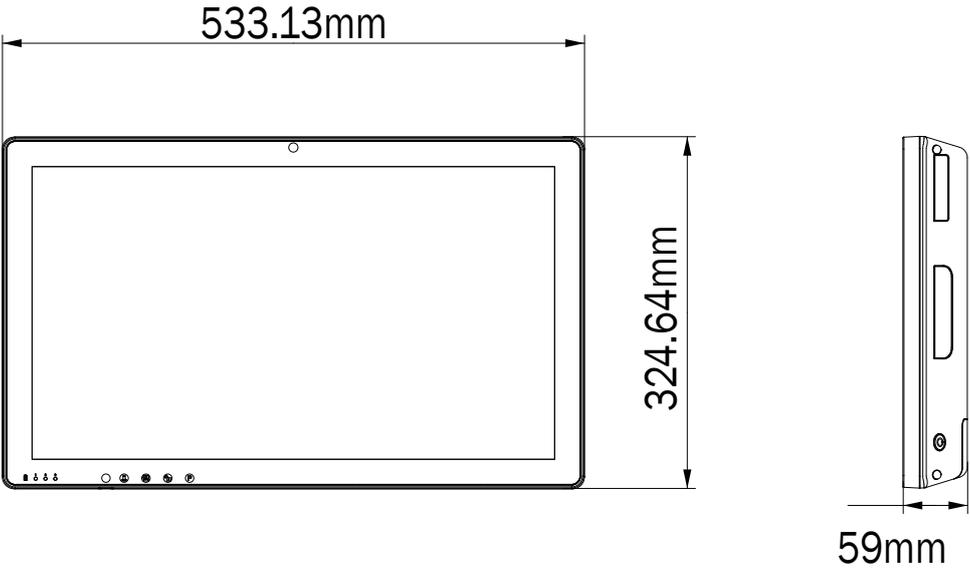

4. Basic Operation

4-1. Powering ON & OFF

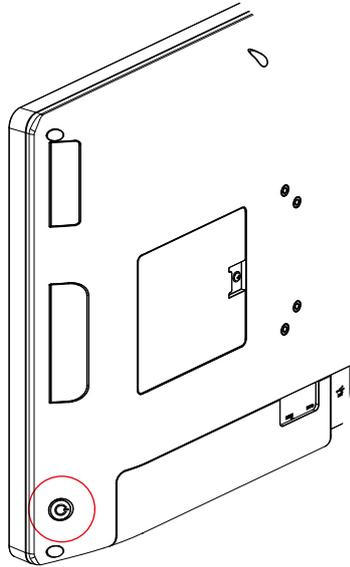

To activate the system, push and quickly release the power button and the display will come on in a few seconds. **NOTE:** The system must be plugged into power adapter or battery charged before turning on for the first time.

To turn off the system, power off the device safely using software function that “shuts down computer” provided in the operating system.

4-2. Charging the Battery

The system is equipped with 3 hot-swappable batteries.

1. The batteries may be charged by connecting the supplied power adapter directly to the DC-in port on the system.
2. Open the cable cover and plug the cable directly into the connector. Then plug the adapter directly into the power outlet.

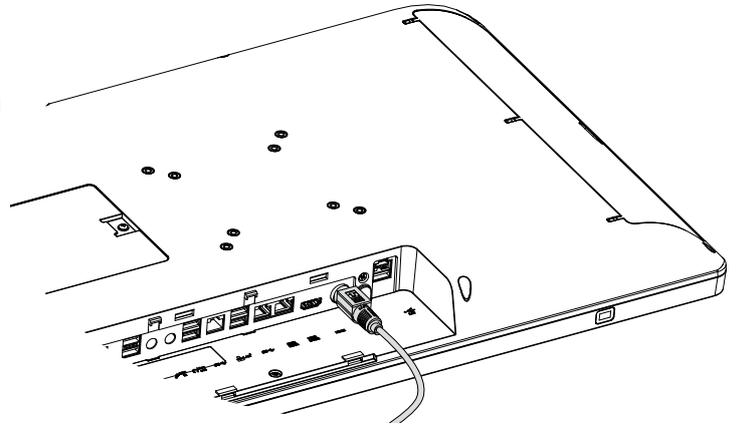

The system will charge in the order of battery 1 to battery 3.

Status will show the capacity of each battery.

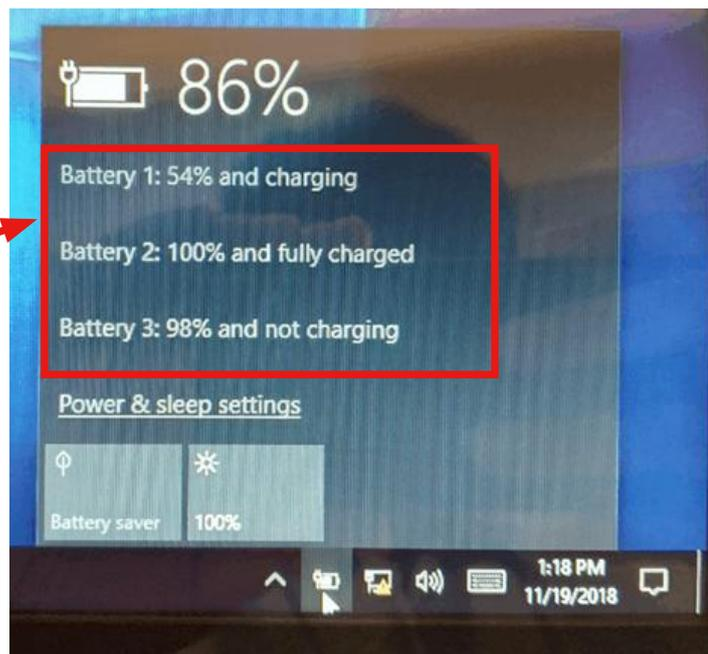

4-3. Battery Level Indication

Each battery provides an battery level indicator LED on the front of the system. The signals charge status are as follows:

DC in Mode	Battery	Battery full charged	GREEN
		Battery charging	GREEN blinks slowly
		Battery standby	GREEN
		Battery error	RED blinks quickly
	Without battery	No signal	
	Battery / Power off	Battery full charged	GREEN
		Battery charging	GREEN blinks slowly
Battery standby		GREEN	
Battery Mode	Battery	Battery discharging	ORANGE blinks slowly
		Battery standby	GREEN
		Battery lower 12%, higher 6%	RED blinks slowly
		Battery 6%	RED
		Battery error	RED blinks quickly
	Without battery	No signal	
	Battery / Power off	No signal	
	Battery / Power off	all batteries lower 6%	RED lights up for 6 seconds

4-4. Battery Discharging Mode Flowchart

Battery discharging will be started from Battery1 when system boot on battery discharging mode.

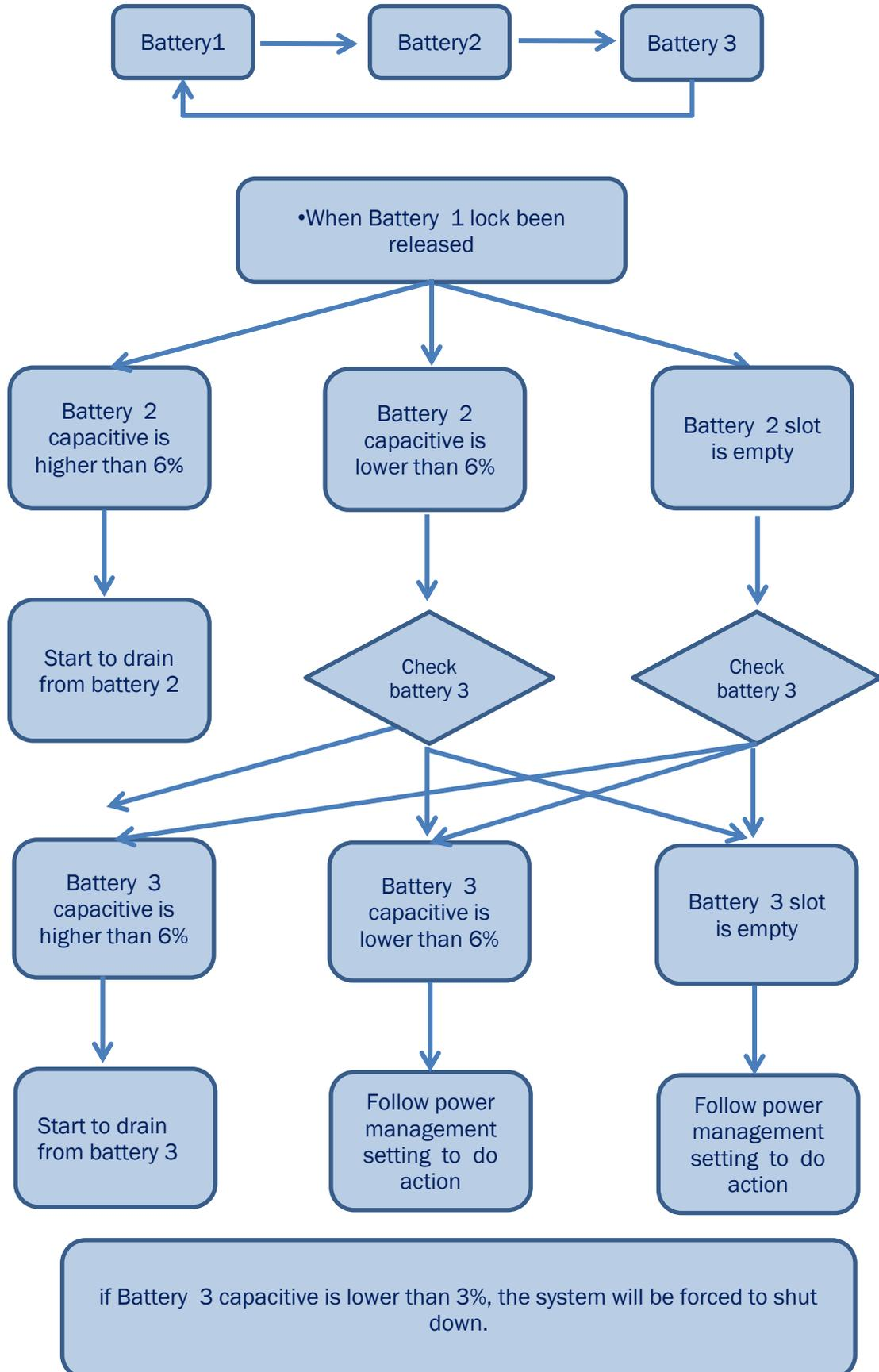

5. System Assembly

5-1. Opening the Cable Cover

1. Place the system face down, make sure not to scratch the screen.
2. Press and pull the cable cover outwards to release it from the system.

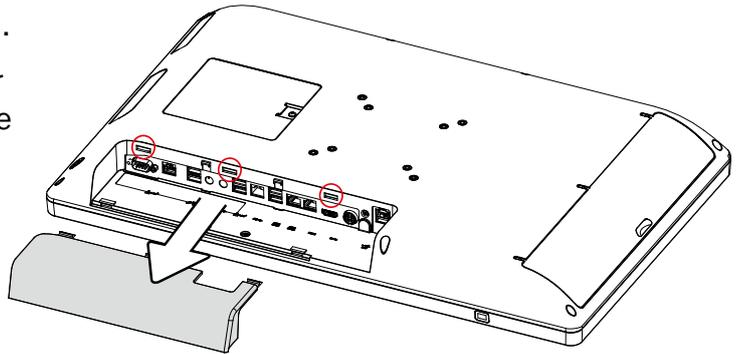

5-2. Replacing the Battery

1. Place the system face down, make sure not to scratch the screen.

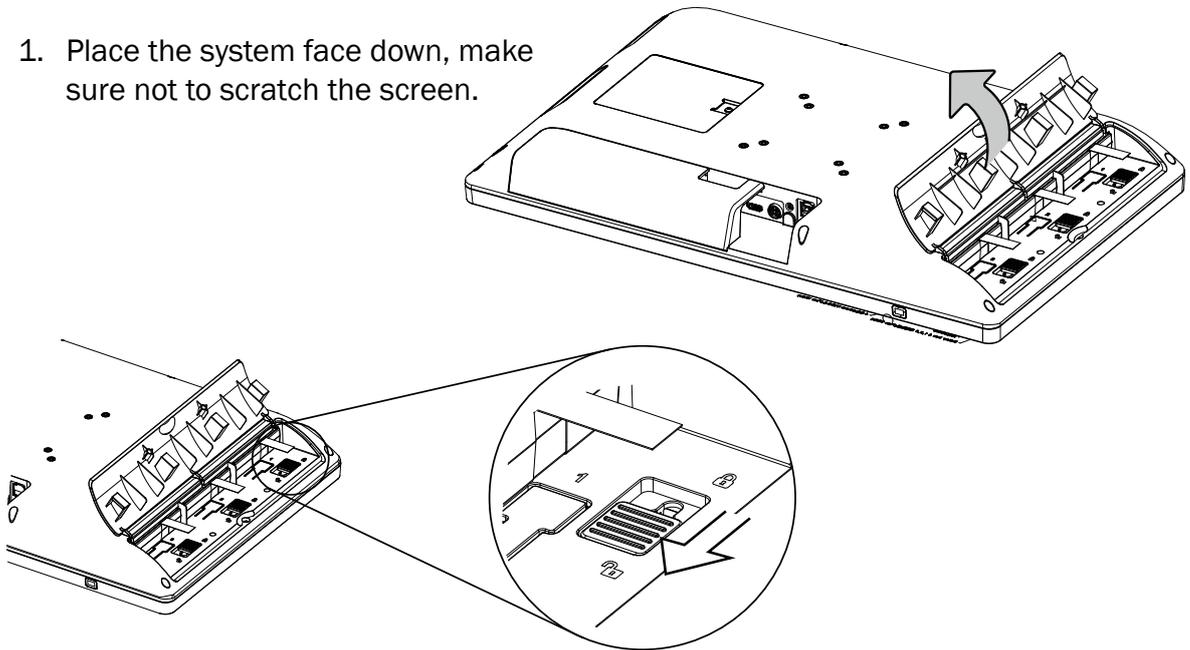

2. Slide the latch down as shown to unlock.
3. Pull the plastic puller (see picture) to release the battery out of the system.

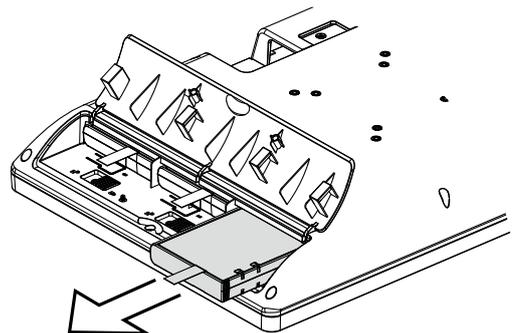

5-3. Replacing the M.2 SSD Card

1. Loosen the screw (x1) and remove the M.2 SSD card door.

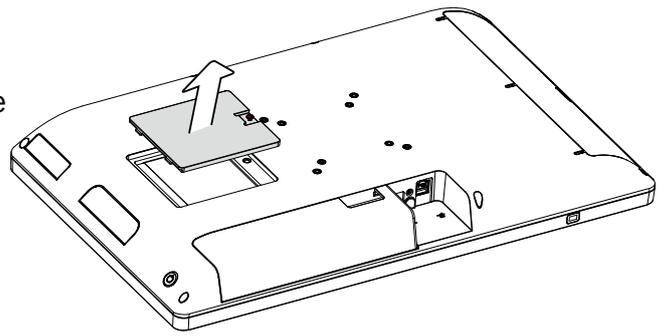

2. An insulator mylar has been applied on the EMI bracket, peel off the mylar to access the M.2 SSD card.

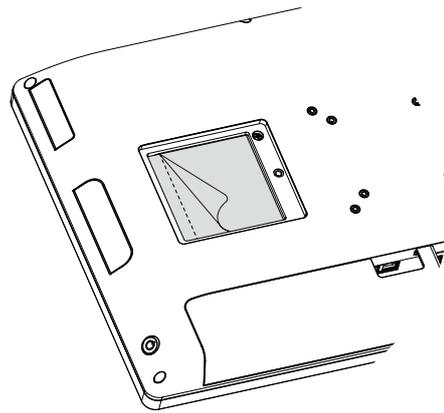

3. Remove the screws (x2) and pull the M.2 SSD cards outwards as shown in the picture.

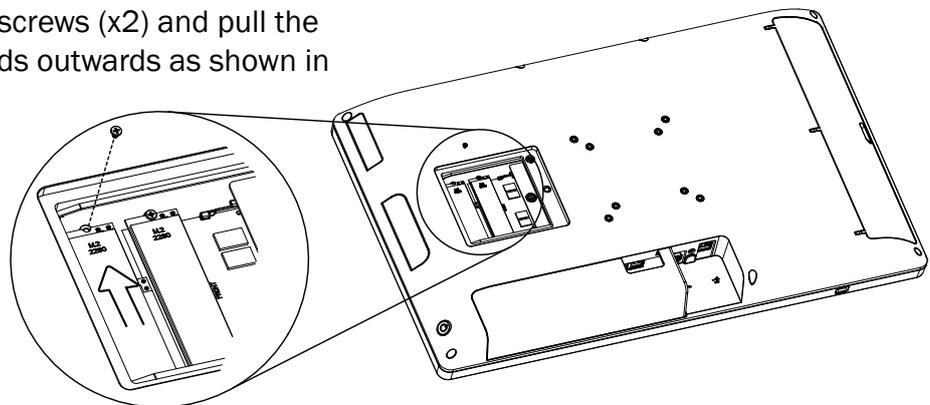

6. Specification

Model Name	K959
Mainboard	F87U
CPU	Intel® Core™ i5-1145G7E
System memory	2 x SO-DIMM,DDR4 3200MHz (32GB Max)
Graphic memory	Intel® Iris® Xe Graphics
TPM 2.0	NUVOTON 750 (option)
LAN controller (GigaLAN)	Intel WG I219 LM (1 st LAN); Intel WG I225 IT (2 nd LAN)
LCD/Touch Panel	
LCD size	21.5" LED LCD
Brightness	250 nits
Maximal resolution	1920 x 1080
Touch screen type	True flat projected capacitive touch
Storage	
Flash memory	M.2 SATA SSD or NVMe SSD
Peripherals	
Web cam (option)	5M Web Cam
RFID (option)	RFID (USB)
Smart card reader (option)	Smart card reader (USB)
Expansion	
M.2	E-key 2230 for WLAN / M-key 2280 for storage / B-key 2280 for storage either one 3052 for USB (4G/5G module)
External I/O Ports	
USB Type A	2 x USB2.0 / 4 x USB 3.0
Serial / COM	2 x RJ48
Isolated COM DB9	1
LAN	2 x RJ45
Audio jack	1 x Mic-in, 1 x Line-out
DC jack	1 x Latch type (4pin)
Powered USB	1 x 24V
Control/ Indicate	
Power button	1
LED indicator	3 dual color LED indicators for 3 battery status
Audio	
Speaker	1 x 2W
Power	
Wide range voltage	12V ~ 48V
Power adapter	DC 19V / 120W
Battery	
Battery	3 x hot swappable battery with 240WHrs capacity
Battery life	10.2 hours base on normal usage with 3 battery
Charging time	5 hours with 1 battery (Validated charging from 6% to 99%)
Communication	
Wireless LAN / Bluetooth	802.11 A/B/G/N/AC/AX, 2.4G/5/6GHz, BT4.2

Model Name	K959
Mainboard	F87U
Environment	
EMC & Safety	FCC/CE Class B/LVD
Certification	IEC / EN 60601-1 IEC / EN60601-1-2:2015 RoHS WEEE REACH
Operating temperature	0 °C ~ 40 °C (32 °F ~ 104 °F) discharge 0 °C ~ 35 °C (32 °F ~ 95 °F) charge
Storage temperature	-20 ° ~ 60 °C (-4 °F ~ 140 °F)
Humidity	10% - 90% RH non-condensing
Sealing	IP65 compliant front panel IPX1 (back enclosure) (option)
Dimensions (W x D x H)	533 x 59 x 325 mm
Weight (N.W.)	5.5KG (w/o Battery)
Mounting	75mm x 75mm /100mm x 100mm standard VESA / panel mount
OS support	UEFI: Windows IOT 10 2021 H2 / Windows 11 (64-bit) Linux: Ubuntu, Fedora

*This specification is subject to change without prior notice.

Manufactory information:

Factory: Flytech Technology Co., Ltd.

Address: NO.36 Huaya 3rd Rd., Guishan Township, Taoyuan County 33383, Taiwan

Tel No: 886-3-272-9688 Fax No: 886-3-272-9666

Adaptor Manufacturer: MEAN WELL ENTERPRISES CO., LTD.

Model:GSM120A20-R7B

7. Configuration

7-1. F87U Motherboard Layout

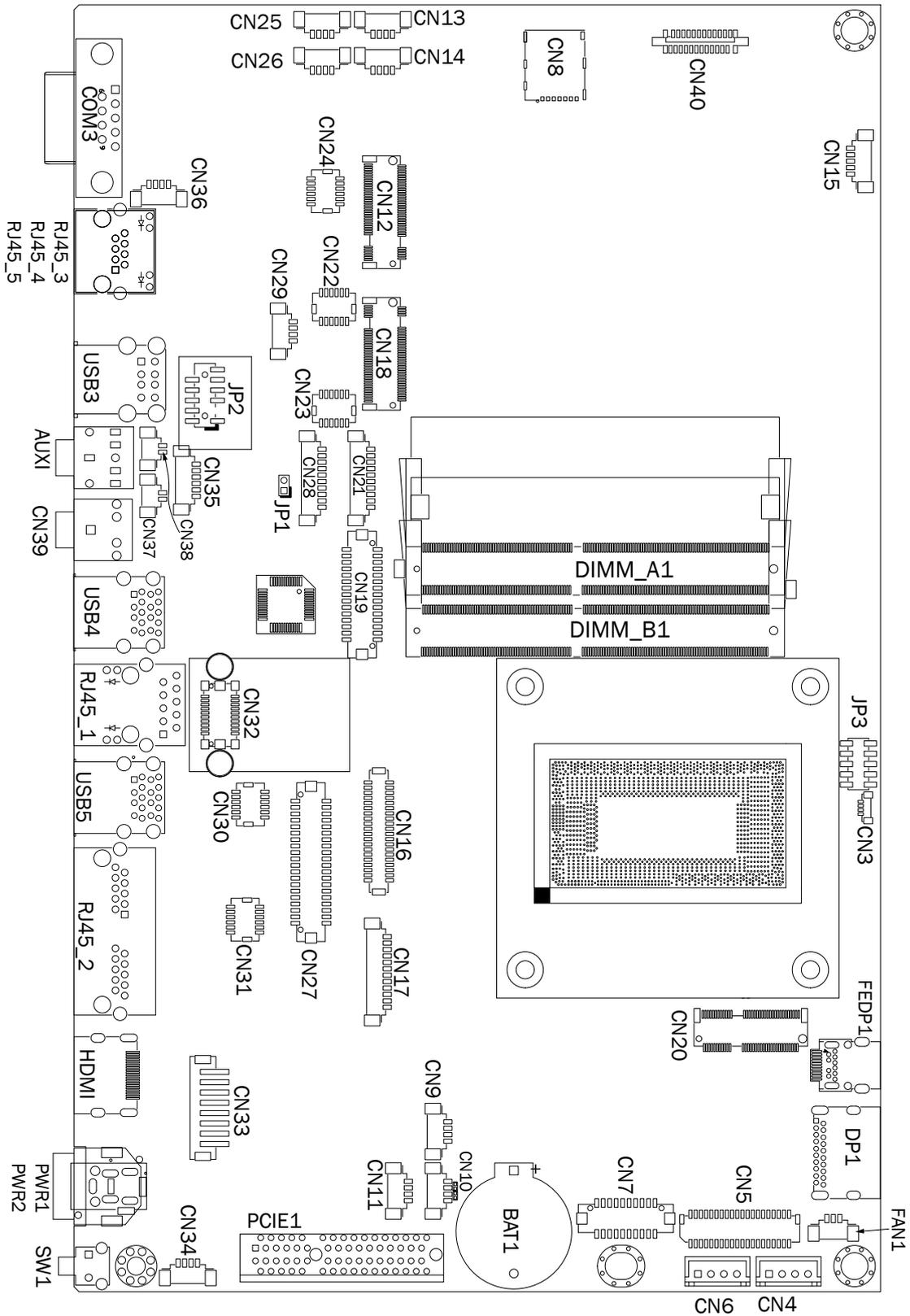

7-2. Connectors & Functions

Connector	Function
CN4/CN6	SATA power connector
CN5	DP/HDMI 40P connector
CN7	Charger BD connector
CN8	Micro-SD card socket
CN9/CN10/CN11/CN13/ CN14/CN25/CN26	Internal USB 2.0 connector
CN12	M.2 slot, B-Key for storage
CN15	EC debug connector
CN16	40Pin eDP Connector
CN17	LVDS connector (power)
CN18	M.2 slot, M-Key for storage
CN19	Bedside connector
CN20	M.2 slot, E-Key for wireless card
CN21	COM5 connector
CN22/CN30	USB to LAN connector (option)
CN23	USB to COM4/COM5 connector (option)
CN24	USB to COM3 connector (option)
CN27	LVDS connector
CN28	COM4 connector
CN29/CN36	LAN2 LED connector
CN31	USB to COM1/COM2 connector (option)
CN32	OOB connector
CN33	Charger battery BD connector
CN34	4Pin power button w/2 LED connector
CN35	Speaker & MIC connector
CN37	Speaker L connector
CN38	Speaker R connector
CN39	Audio jack
CN40	Power sequence test connector
DIMM_A1/DIMM_B1	SO-DIMM socket
PCIE1	PCI-E X4 slot
BAT1	RTC battery connector
FAN1	FAN connector
DP1	DP connector
FEDP1	2 nd FeDP connector
SW1	Power button
PWR1/PWR2	DC-In connector
HDMI	HDMI connector
AUXI	MIC-In connector
RJ45_1	LAN connector
RJ45_2	COM1/COM2 connector
RJ45_3/RJ45_4/RJ45_5	LAN2 connector
COM3	COM3 connector
USB3	USB 2.0 connector
USB4/USB5	USB 3.0 connector
JP1	Speaker selection jumper
JP2	TPM connector
JP3	LCD ID jumper

Note: Connectors and jumpers will be different according to product difference, the real object should be considered as final. Contact your POS Systems authorized distributor or reseller for technical information or specific device configuration.

7-3. Jumper Setting

Speaker Selection Jumper

Function	JP1
Stereo	<div style="border: 1px solid black; padding: 2px; display: inline-block;">1</div> <div style="border: 1px solid black; padding: 2px; display: inline-block;">2</div>
▲ Rerved (Line-out)	1 2

LCD ID Jumper

Panel#	Resolution	LVDS		Output Interface	JP3
		Bits	Channel		
13	SSC funtion use			LVDS Panel	1 <div style="border: 1px solid black; padding: 2px; display: inline-block;">3</div> 5 7 9 2 <div style="border: 1px solid black; padding: 2px; display: inline-block;">4</div> 6 8 10
15	1920 x 1080	24	Dual	LVDS Panel	1 3 5 7 9 2 4 6 8 10

1
2 Jumper open
 1
2 Jumper short
 ▲ = Manufacturer Default Setting

COM1/COM2 Power Setting

COM1, COM2 can be set to provide power to your serial device. The voltage can be set to +5V or +12V in the BIOS.



1. Power on the system, and press the key when the system is booting up to enter the BIOS Setup utility.
2. Select the Advanced tab.
3. Select **MISC. Power Configuration** Ports and press <Enter> to go to display the available options.
4. To enable the power, select COM1 ,COM2 Power setting and press <Enter>. Select Power and press <Enter>. Save the change by pressing F10.