



FCC PART 15 SUBPART C TEST REPORT

FCC PART 15.247

Report Reference No.....: **WE11040011**

FCC ID.....: **X5QRD77760**

Compiled by
 (position+printed name+signature)..: File administrators Wenliang Li

Supervised by
 (position+printed name+signature)..: Test Engineer Eric Zhang

Approved by
 (position+printed name+signature)..: Manager Jimmy Li

Date of issue.....: May 13, 2011

Testing Laboratory Name: **Shenzhen Huatongwei International Inspection Co., Ltd**

Address: Keji Nan No.12 Road, Hi-tech Park, Shenzhen, China

Applicant's name: **Jetlun(ShenZhen)Corporation**

Address: 1008A Skyworth Building Gao-xin RD South High-tech Park
 Nanshan District Shenzhen China

Test specification:

Standard.....: **FCC Part 15.247: Operation within the bands 920-928 MHz, 2400-2483.5 MHz and 5725-5850 MHz Direct Sequence System**

TRF Originator.....: Shenzhen Huatongwei International Inspection CO., Ltd

Master TRF.....: Dated 2006-06

Shenzhen Huatongwei International Inspection Co., Ltd. All rights reserved.

This publication may be reproduced in whole or in part for non-commercial purposes as long as the Shenzhen Huatongwei International Inspection Co., Ltd is acknowledged as copyright owner and source of the material. Shenzhen Huatongwei International Inspection Co., Ltd takes no responsibility for and will not assume liability for damages resulting from the reader's interpretation of the reproduced material due to its placement and context.

Test item description: Zigbee Occupancy sensor

Trade Mark: /

Model/Type reference.....: RD77760

Listed Models: /

Result.....: **Positive**

TEST REPORT

Test Report No. :	WE11040011	May 13, 2011
		Date of issue

Equipment under Test : Zigbee Occupancy sensor

Model /Type : RD77760

Listed Models : /

Applicant : **Jetlun(ShenZhen)Corporation**

Address : 1008A Skyworth Building Gao-xin RD South High-tech Park Nanshan District Shenzhen China.

Manufacturer : **ZhuHai YueHua Electronic Co.,Ltd.**

Address : 13, Pingdong Road4, NanPing Science&Technology Industrial Garden,Zhuhai,China.

Test Result according to the standards on page 7:	Positive
--	-----------------

The test report merely corresponds to the test sample.
It is not permitted to copy extracts of these test result without the written permission of the test laboratory.

Contents

1.	<u>TEST STANDARDS</u>	<u>4</u>
2.	<u>SUMMARY</u>	<u>5</u>
2.1.	General Remarks	5
2.2.	Equipment Under Test	5
2.3.	Short description of the Equipment under Test (EUT)	5
2.4.	EUT operation mode	5
2.5.	EUT configuration	6
2.6.	Related Submittal(s) / Grant (s)	6
2.7.	Modifications	6
2.8.	NOTE	6
3.	<u>TEST ENVIRONMENT.....</u>	<u>7</u>
3.1.	Address of the test laboratory	7
3.2.	Test Facility	7
3.3.	Environmental conditions	8
3.4.	Configuration of Tested System	8
3.5.	Test Description	8
3.6.	Statement of the measurement uncertainty	8
3.7.	Equipments Used during the Test	9
4.	<u>TEST CONDITIONS AND RESULTS.....</u>	<u>10</u>
4.1.	AC Power Conducted Emission	10
4.2.	Radiated Emission	13
4.3.	Maximum Peak Output Power	20
4.4.	Power Spectral Density	24
4.5.	Band Edge Compliance of RF Emission	29
4.6.	Spurious RF Conducted Emission	32
4.7.	6dB Bandwidth	37
4.8.	Antenna Requirement	41

1. TEST STANDARDS

The tests were performed according to following standards:

[FCC Rules Part 15.247](#): Frequency Hopping, Direct Spread Spectrum and Hybrid Systems that are in operation within the bands of 902-928 MHz, 2400-2483.5 MHz, and 5725-5850 MHz.

[ANSI C63.10-2009](#): American National Standard for Testing Unlicensed Wireless Devices

2. SUMMARY

2.1. General Remarks

Date of receipt of test sample : Apr 21, 2011

Testing commenced on : Apr 21, 2011

Testing concluded on : May 13, 2011

2.2. Equipment Under Test

Power supply system utilised

Power supply voltage : 120V / 60 Hz 115V / 60Hz
 12 V DC 24 V DC
 Other (specified in blank below)

DC 9.0V from battery or AC Adapter

2.3. Short description of the Equipment under Test (EUT)

2.4GHz (Zigbee Occupancy sensor (RD77760)) For more details, refer to the user's manual of the EUT.

Serial number: Prototype

2.4. EUT operation mode

The EUT has been tested under typical operating condition. The Applicant provides AT command to control the EUT for staying in continuous transmitting and receiving mode for testing. There are sixteen channels of EUT, and the test carried out at the channel 11(lowest), channel 18(middle) and channel 26 (highest) channels.

Channel	Frequency	Channel	Frequency
11	2405 MHz	19	2445 MHz
12	2410 MHz	20	2450 MHz
13	2415 MHz	21	2455 MHz
14	2420 MHz	22	2460 MHz
15	2425 MHz	23	2465 MHz
16	2430 MHz	24	2470 MHz
17	2435 MHz	25	2475 MHz
18	2440 MHz	26	2480 MHz

2.5. EUT configuration

The following peripheral devices and interface cables were connected during the measurement:

- - supplied by the manufacturer
- - supplied by the lab

- Power Cable Length (m) : /
Shield : /
Detachable : /
- Multimeter Manufacturer : /
Model No. : /

Adapter: Model: GME053-0903-US
 Input:100-240V~50/60Hz 0.15A
 Output: DC 9V 0.3A
 Power Cable: 150cm
 ◇ Shielded ◆ Unshielded

2.6. Related Submittal(s) / Grant (s)

This submittal(s) (test report) is intended for **FCC ID: X5QRD77760** filing to comply with Section 15.247 of the FCC Part 15, Subpart C Rules.

2.7. Modifications

No modifications were implemented to meet testing criteria.

2.8. NOTE

1. The EUT is an IEEE 802.15 ZigBee Standard type device, The functions of the EUT listed as below:

	Test Standards	Reference Report
Zigbee	FCC Part 15 Subpart C (Section15.247)	WE11040011

2. The frequency bands used in this EUT are listed as follows:

Frequency Band(MHz)	2400-2483.5	5150-5350	5470-5725	5725-5850
Zigbee	√	—	—	—

3. The EUT provides one completed transmitter and receiver.

Modulation Mode	TX Function
Zigbee	1TX

3. TEST ENVIRONMENT

3.1. Address of the test laboratory

Shenzhen Huatongwei International Inspection Co., Ltd
Keji Nan No.12 Road, Hi-tech Park, Shenzhen, China
Phone: 86-755-26715686 Fax: 86-755-26748089

The sites are constructed in conformance with the requirements of ANSI C63.7, ANSI C63.4 (2009) and CISPR Publication 22.

3.2. Test Facility

The test facility is recognized, certified, or accredited by the following organizations:

CNAS-Lab Code: L1225

Shenzhen Huatongwei International Inspection Co., Ltd has been assessed and proved to be in compliance with CNAS-CL01 Accreditation Criteria for Testing and Calibration Laboratories (identical to ISO/IEC 17025: 2005 General Requirements) for the Competence of Testing and Calibration Laboratories, Date of Registration: Mar 30, 2009. Valid time is until Mar 29, 2012.

A2LA-Lab Cert. No. 2243.01

Shenzhen Huatongwei International Inspection Co., Ltd, EMC Laboratory has been accredited by A2LA for technical competence in the field of electrical testing, and proved to be in compliance with ISO/IEC 17025: 2005 General Requirements for the Competence of Testing and Calibration Laboratories and any additional program requirements in the identified field of testing. Valid time is until Sept 30, 2011.

FCC-Registration No.: 662850

Shenzhen Huatongwei International Inspection Co., Ltd, EMC Laboratory has been registered and fully described in a report filed with the FCC (Federal Communications Commission). The acceptance letter from the FCC is maintained in our files. Registration 662850, Renewal date Jun 01, 2009.

IC-Registration No.: 5377

The 3m Alternate Test Site of Shenzhen Huatongwei International Inspection Co., Ltd has been registered by Certification and Engineering Bureau of Industry Canada for the performance of radiated measurements with Registration No. 5377 on Jan 25, 2011. Valid time is until Jan 24, 2014

ACA

Shenzhen Huatongwei International Inspection Co., Ltd, EMC Laboratory can also perform testing for the Australian C-Tick mark as a result of our A2LA accreditation.

NEMKO-Aut. No.: ELA125

Shenzhen Huatongwei International Inspection Co., Ltd has been assessed the quality assurance system, the testing facilities, qualifications and testing practices of the relevant parts of the organization. The quality assurance system of the Laboratory has been validated against ISO/IEC 17025:2005 or equivalent. The laboratory also fulfils the conditions described in Nemko Document NLA-10, the Authorization is valid through July 07, 2011.

VCCI

The 3m Semi-anechoic chamber (12.2m×7.95m×6.7m) and Shielded Room (8m×4m×3m) of Shenzhen Huatongwei International Inspection Co., Ltd has been registered in accordance with the Regulations for Voluntary Control Measures with Registration No.: R-2484. Date of Registration: December 20, 2006. Valid time is until December 20, 2012.

Main Ports Conducted Interference Measurement of Shenzhen Huatongwei International Inspection Co., Ltd has been registered in accordance with the Regulations for Voluntary Control Measures with Registration No.: C-2726. Date of Registration: December 20, 2006. Valid time is until December 19, 2012.

DNV

Shenzhen Huatongwei International Inspection Co Ltd has been found to comply with the requirements of DNV towards subcontractor of EMC and safety testing services in conjunction with the EMC and Low voltage Directives and in the voluntary field. The acceptance is based on a formal quality Audit and follow-ups according to relevant parts of ISO/IEC Guide 17025(2005), in accordance with the requirements of the DNV Laboratory Quality Manual towards subcontractors. Valid time is until Aug 24, 2013.

3.3. Environmental conditions

During the measurement the environmental conditions were within the listed ranges:

Temperature:	<u>15-35 ° C</u>
Humidity:	<u>30-60 %</u>
Atmospheric pressure:	<u>950-1050mbar</u>

3.4. Configuration of Tested System

Fig. 2-1 Configuration of Tested System



3.5. Test Description

FCC PART 15		
FCC Part 15.207	AC Power Conducted Emission	PASS
FCC Part 15.247(a)(2)	6dB Bandwidth	PASS
FCC Part 15.247(d)	Spurious RF Conducted Emission	PASS
FCC Part 15.247(b)	Maximum Peak Output Power	PASS
FCC Part 15.247(e)	Power Spectral Density	PASS
FCC Part 15.109/ 15.205/ 15.209	Radiated Emissions	PASS
FCC Part 15.247(d)	Band Edge Compliance of RF Emission	PASS
FCC Part 15.203/15.247 (b)	Antenna Requirement	PASS

Remark: The measurement uncertainty is not included in the test result.

3.6. Statement of the measurement uncertainty

The data and results referenced in this document are true and accurate. The reader is cautioned that there may be errors within the calibration limits of the equipment and facilities. The measurement uncertainty was calculated for all measurements listed in this test report acc. to CISPR 16 - 4 „Specification for radio disturbance and immunity measuring apparatus and methods – Part 4: Uncertainty in EMC Measurements“ and is documented in the Shenzhen Huatongwei International Inspection Co., Ltd quality system acc. to DIN EN ISO/IEC 17025. Furthermore, component and process variability of devices similar to that tested may result in additional deviation. The manufacturer has the sole responsibility of continued compliance of the device.

Hereafter the best measurement capability for Shenzhen Huatongwei laboratory is reported:

Test	Range	Measurement Uncertainty	Notes
Radiated Emission	30~1000MHz	4.24 dB	(1)
Radiated Emission	1~18GHz	5.16 dB	(1)
Radiated Emission	18-40GHz	5.54 dB	(1)
Conducted Disturbance	0.15~30MHz	3.39 dB	(1)

(1) This uncertainty represents an expanded uncertainty expressed at approximately the 95% confidence level using a coverage factor of k=2.

3.7. Equipments Used during the Test

Test equipments					
Item	Test Equipment	Manufacturer	Model No.	Serial No.	Last Cal.
1	ULTRA-BROADBAND ANTENNA	ROHDE & SCHWARZ	HL562	100015	2010/05/30
2	EMI TEST RECEIVER	ROHDE & SCHWARZ	ESI 26	100009	2010/10/24
3	Spectrum Analyzer	AGILENT	E4407B	MY44210775	2010/07/21
4	RF TEST PANEL	ROHDE & SCHWARZ	TS / RSP	335015/ 0017	2010/10/24
5	TURNTABLE	ETS	2088	2149	2010/10/24
6	ANTENNA MAST	ETS	2075	2346	2010/10/24
7	EMI TEST SOFTWARE	ROHDE & SCHWARZ	ESK1	N/A	2010/10/24
8	HORN ANTENNA	ROHDE &SCHWARZ	HF906	100039	2010/11/01
9	Amplifer	Sonoma	310N	E009-13	2010/10/24
10	JS amplifer	ROHDE &SCHWARZ	JS4-00101800-28-5A	F201504	2010/11/01
11	High pass filter	Compliance Direction systems	BSU-6	34202	2010/10/24
12	EMI Test Receiver	ROHDE & SCHWARZ	ESCI	100106	2010/10/24
13	Artificial Mains	ROHDE & SCHWARZ	ESH2-Z5	100028	2010/10/24
14	Pulse Limiter	ROHDE & SCHWARZ	ESHSZ2	100044	2010/10/24
15	EMI Test Software	ROHDE & SCHWARZ	ESK1	N/A	2010/10/24

4. TEST CONDITIONS AND RESULTS

4.1. AC Power Conducted Emission

TEST CONFIGURATION

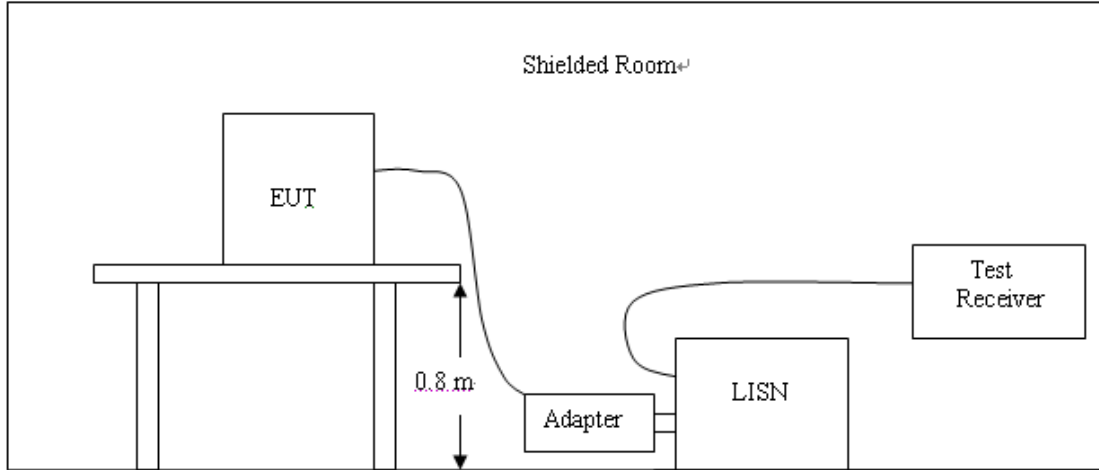

TEST PROCEDURE

- 1 The equipment was set up as per the test configuration to simulate typical actual usage per the user's manual. The EUT is a tabletop system, a wooden table with a height of 0.8 meters is used and is placed on the ground plane as per ANSI C63.10-2009.
- 2 Support equipment, if needed, was placed as per ANSI C63.10-2009
- 3 All I/O cables were positioned to simulate typical actual usage as per ANSI C63.10-2009
- 4 The EUT received DC5V power from the adapter, the adapter received AC120V/60Hz power through a Line Impedance Stabilization Network (LISN) which supplied power source and was grounded to the ground plane.
- 5 All support equipments received AC power from a second LISN, if any.
- 6 The EUT test program was started. Emissions were measured on each current carrying line of the EUT using a spectrum Analyzer / Receiver connected to the LISN powering the EUT. The LISN has two monitoring points: Line 1 (Hot Side) and Line 2 (Neutral Side). Two scans were taken: one with Line 1 connected to Analyzer / Receiver and Line 2 connected to a 50 ohm load; the second scan had Line 1 connected to a 50 ohm load and Line 2 connected to the Analyzer / Receiver.
- 7 Analyzer / Receiver scanned from 150 KHz to 30MHz for emissions in each of the test modes.
- 8 During the above scans, the emissions were maximized by cable manipulation.

AC Power Conducted Emission Limit

For intentional device, according to § 15.207(a) AC Power Conducted Emission Limits is as following :

Frequency (MHz)	Maximum RF Line Voltage (dBµV)			
	CLASS A		CLASS B	
	Q.P.	Ave.	Q.P.	Ave.
0.15 - 0.50	79	66	66-56*	56-46*
0.50 - 5.00	73	60	56	46
5.00 - 30.0	73	60	60	50

* Decreasing linearly with the logarithm of the frequency

TEST RESULTS

SCAN TABLE: "Voltage (9K-30M) FIN"

Short Description: 150K-30M Voltage

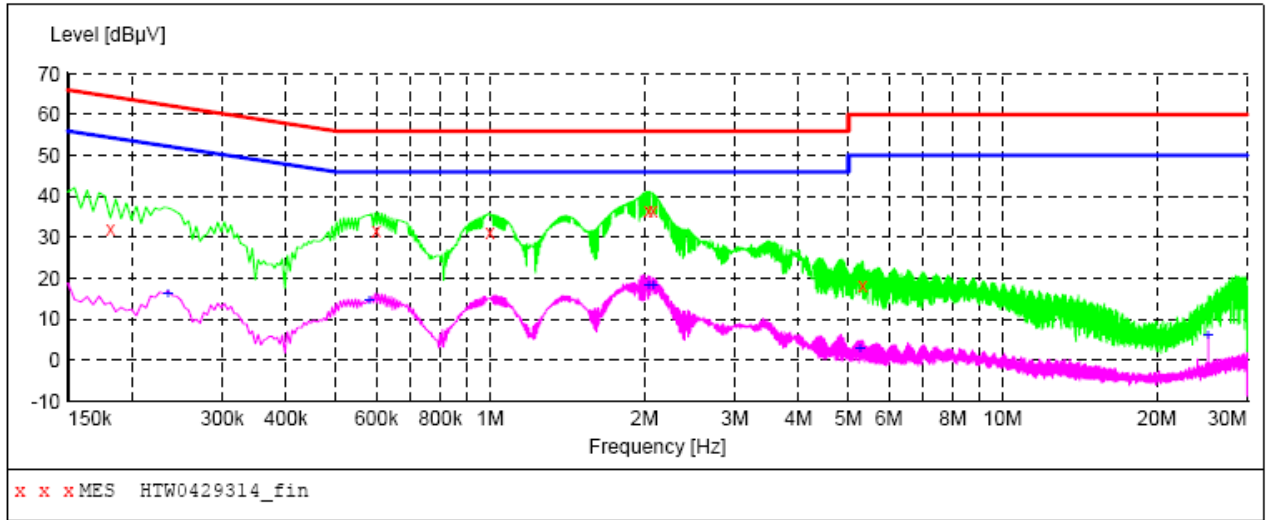

MEASUREMENT RESULT: "HTW0429314_fin"

4/29/2011 3:29PM

Frequency MHz	Level dBµV	Transd dB	Limit dBµV	Margin dB	Detector	Line	PE
0.181500	32.00	10.3	64	32.4	QP	L1	GND
0.600000	31.60	10.2	56	24.4	QP	L1	GND
1.000500	31.20	10.4	56	24.8	QP	L1	GND
2.035500	36.70	10.5	56	19.3	QP	L1	GND
2.080500	36.30	10.5	56	19.7	QP	L1	GND
5.334000	18.30	10.6	60	41.7	QP	L1	GND

MEASUREMENT RESULT: "HTW0429314_fin2"

4/29/2011 3:29PM

Frequency MHz	Level dBµV	Transd dB	Limit dBµV	Margin dB	Detector	Line	PE
0.235500	16.20	10.2	52	36.1	AV	L1	GND
0.582000	14.70	10.2	46	31.3	AV	L1	GND
2.040000	18.40	10.5	46	27.6	AV	L1	GND
2.085000	18.30	10.5	46	27.7	AV	L1	GND
5.271000	2.80	10.6	50	47.2	AV	L1	GND
25.201500	6.10	11.2	50	43.9	AV	L1	GND

SCAN TABLE: "Voltage (9K-30M) FIN"

Short Description: 150K-30M Voltage

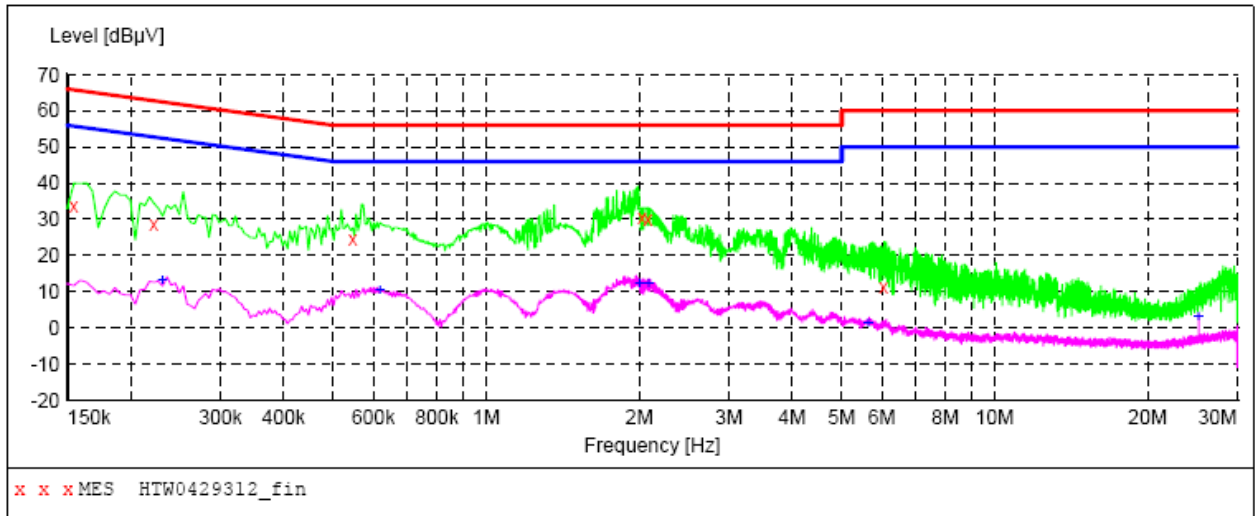

MEASUREMENT RESULT: "HTW0429312_fin"

4/29/2011 3:25PM

Frequency MHz	Level dBµV	Transd dB	Limit dBµV	Margin dB	Detector	Line	PE
0.154500	33.70	10.3	66	32.1	QP	N	GND
0.222000	28.50	10.3	63	34.2	QP	N	GND
0.546000	24.40	10.2	56	31.6	QP	N	GND
2.026500	30.40	10.5	56	25.6	QP	N	GND
2.080500	30.10	10.5	56	25.9	QP	N	GND
6.045000	11.50	10.6	60	48.5	QP	N	GND

MEASUREMENT RESULT: "HTW0429312_fin2"

4/29/2011 3:25PM

Frequency MHz	Level dBµV	Transd dB	Limit dBµV	Margin dB	Detector	Line	PE
0.231000	13.00	10.3	52	39.4	AV	N	GND
0.618000	10.50	10.2	46	35.5	AV	N	GND
2.004000	12.20	10.5	46	33.8	AV	N	GND
2.089500	12.30	10.5	46	33.7	AV	N	GND
5.649000	1.20	10.6	50	48.8	AV	N	GND
25.201500	3.20	11.2	50	46.8	AV	N	GND

4.2. Radiated Emission

TEST CONFIGURATION

(a) Radiated Emission Test Set-Up, Frequency below 1000MHz

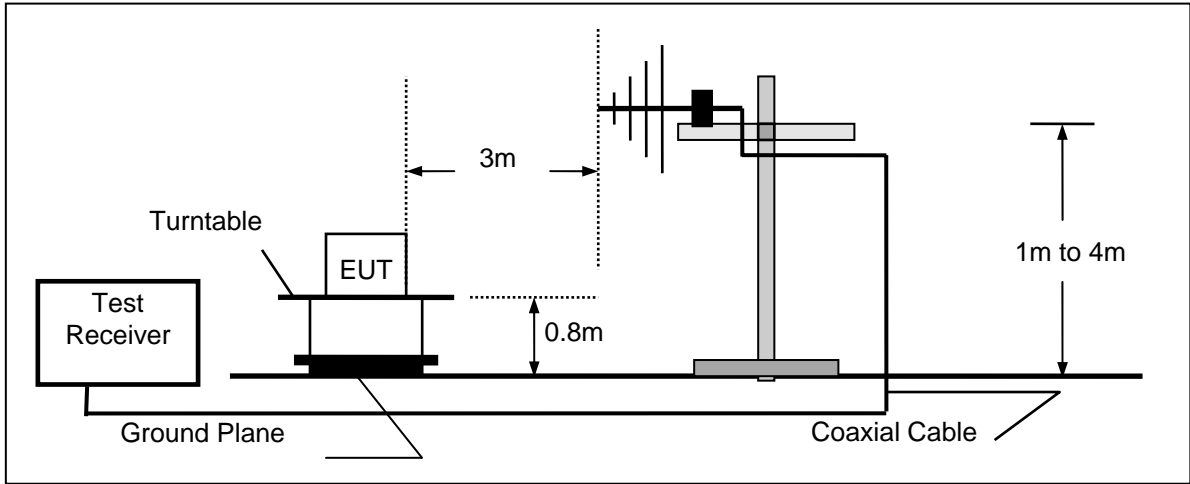

(b) Radiated Emission Test Set-Up, Frequency above 1000MHz

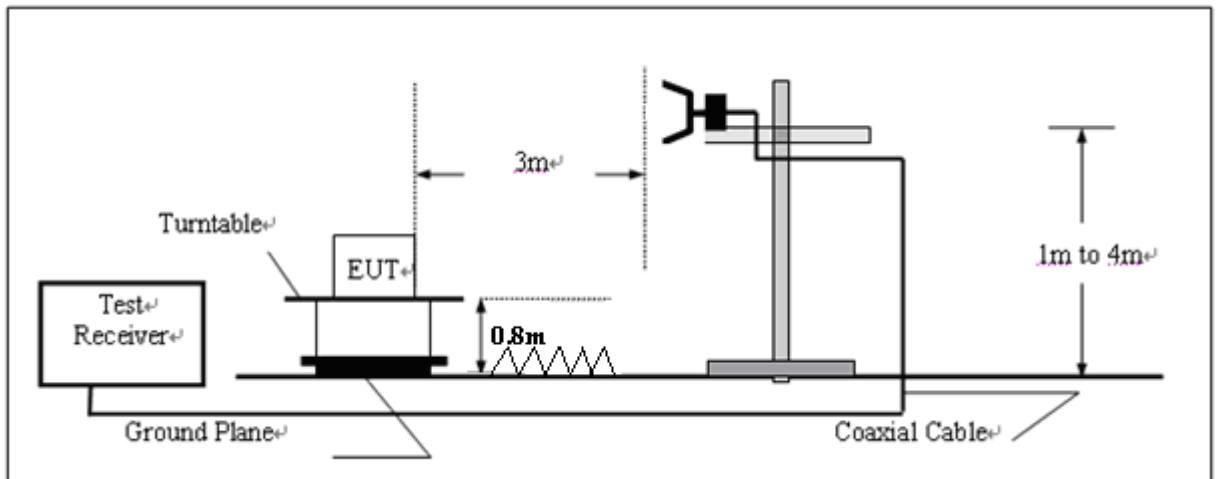

TEST PROCEDURE

- 1 The EUT was placed on a turn table which is 0.8m above ground plane.
- 2 Maximum procedure was performed by raising the receiving antenna from 1m to 4m and rotating the turn table from 0° to 360° to acquire the highest emissions from EUT
3. And also, each emission was to be maximized by changing the polarization of receiving antenna both horizontal and vertical.
4. Repeat above procedures until all frequency measurements have been completed.

Field Strength Calculation

The field strength is calculated by adding the Antenna Factor and Cable Factor and subtracting the Amplifier Gain and Duty Cycle Correction Factor(if any) from the measured reading. The basic equation with a sample calculation is as follows:

$$FS = RA + AF + CL - AG$$

Where FS = Field Strength	CL = Cable Attenuation Factor (Cable Loss)
RA = Reading Amplitude	AG = Amplifier Gain
AF = Antenna Factor	

For example

Frequency (MHz)	FS (dBµV/m)	RA (dBµV/m)	AF (dB)	CL (dB)	AG (dB)	Transd (dB)
300.00	40	58.1	12.2	1.6	31.90	-18.1

Transd=AF +CL-AG

RADIATION LIMIT

For intentional device, according to § 15.209(a), the general requirement of field strength of radiated emission from intentional radiators at a distance of 3 meters shall not exceed the following table. According to § 15.247(d), in any 100kHz bandwidth outside the frequency band in which the EUT is operating, the radio frequency power that is produced by the intentional radiator shall be at least 20dB below that in the100kHz bandwidth within the band that contains the highest level of desired power.

Frequency (MHz)	Distance (Meters)	Radiated (dBµV/m)	Radiated (µV/m)
30-88	3	40.0	100
88-216	3	43.5	150
216-960	3	46.0	200
Above 960	3	54.0	500

TEST RESULTS

For 30MHz to 1000MHz

SCAN TABLE: "test Field(30M-1G)QP"

Short Description:			Field Strength(30M-1G)			
Start	Stop	Step	Detector	Meas. Time	IF Bandw.	Transducer
Frequency	Frequency	Width				
30.0 MHz	1.0 GHz	60.0 kHz	QuasiPeak	1.0 s	120 kHz	HL562 10

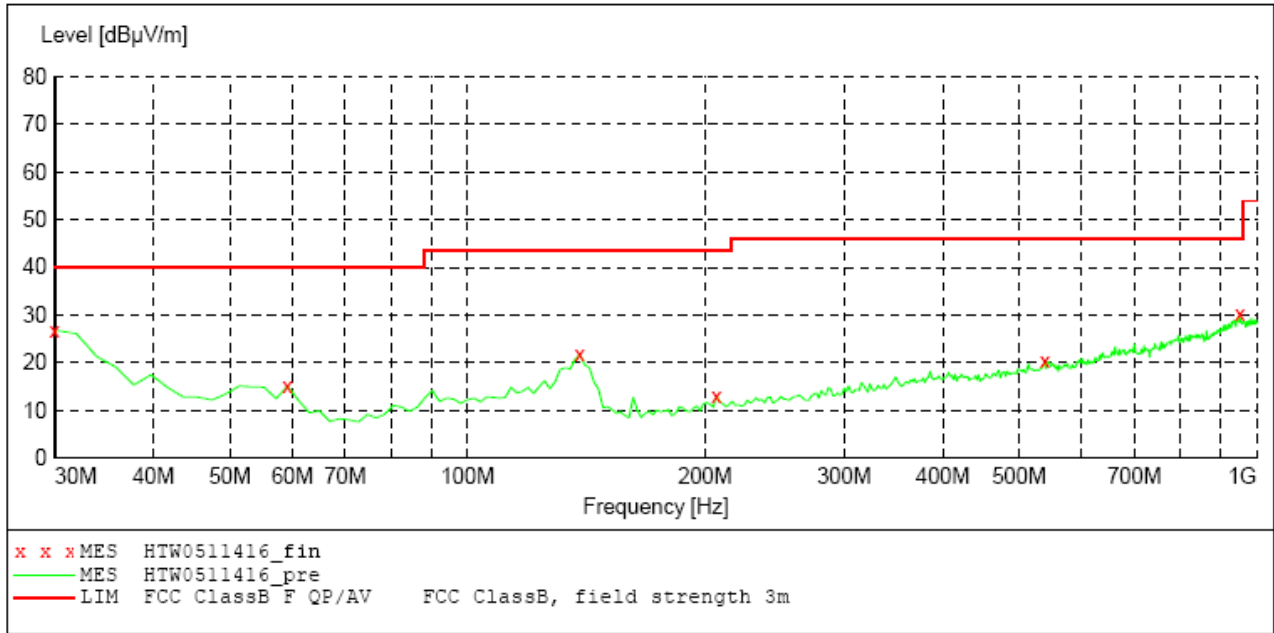

MEASUREMENT RESULT: "HTW0511416_fin"

5/11/2011 8:37PM

Frequency MHz	Level dBµV/m	Transd dB	Limit dBµV/m	Margin dB	Det.	Height cm	Azimuth deg	Polarization
30.000000	26.80	-10.2	40.0	13.2	QP	100.0	133.00	VERTICAL
59.158317	15.20	-24.8	40.0	24.8	QP	100.0	355.00	VERTICAL
138.857715	21.70	-21.0	43.5	21.8	QP	100.0	263.00	VERTICAL
206.893788	13.00	-21.3	43.5	30.5	QP	100.0	316.00	VERTICAL
539.298597	20.30	-13.9	46.0	25.7	QP	100.0	156.00	VERTICAL
953.346693	30.20	-5.2	46.0	15.8	QP	100.0	296.00	VERTICAL

REMARKS :

1. *Undetectable
2. The IF bandwidth of EMI Test Receiver was 120KHz for measuring from 30 MHz to 1 GHz and 1 MHz for measuring above 1 GHz
3. The Transd=Cabel loss +Antenna factor -pre-amplifier factor
4. The pre-test have done for the EUT in three axes and found the worst emission at position shown in test setup photos. The worst case data is recorded in the report.

SCAN TABLE: "test Field(30M-1G)QP"

Short Description:			Field Strength(30M-1G)			
Start	Stop	Step	Detector	Meas. Time	IF Bandw.	Transducer
Frequency	Frequency	Width				
30.0 MHz	1.0 GHz	60.0 kHz	QuasiPeak	1.0 s	120 kHz	HL562 10

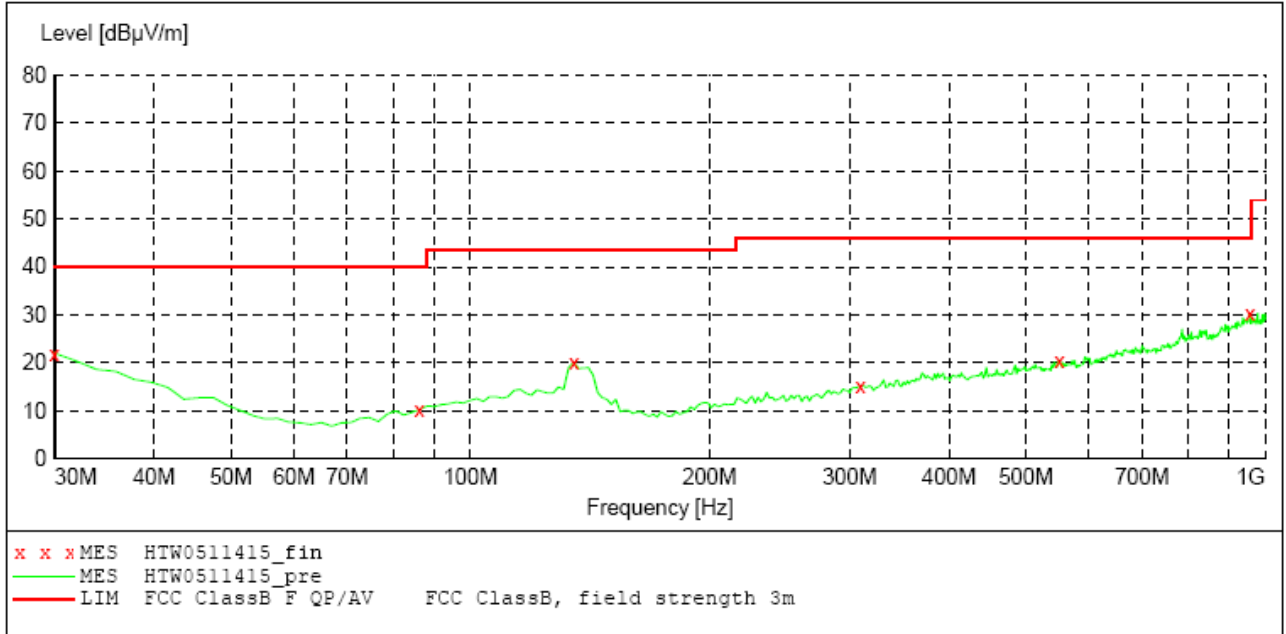

MEASUREMENT RESULT: "HTW0511415_fin"

5/11/2011 8:36PM

Frequency MHz	Level dBµV/m	Transd dB	Limit dBµV/m	Margin dB	Det.	Height cm	Azimuth deg	Polarization
30.000000	22.00	-10.2	40.0	18.0	QP	300.0	220.00	HORIZONTAL
86.372745	10.30	-21.7	40.0	29.7	QP	300.0	284.00	HORIZONTAL
134.969940	20.10	-20.4	43.5	23.4	QP	300.0	360.00	HORIZONTAL
309.919840	15.10	-17.7	46.0	30.9	QP	100.0	146.00	HORIZONTAL
550.961924	20.60	-13.2	46.0	25.4	QP	100.0	160.00	HORIZONTAL
957.234469	30.30	-5.3	46.0	15.7	QP	100.0	242.00	HORIZONTAL

REMARKS :

- *Undetectable
- The IF bandwidth of EMI Test Receiver was 120KHz for measuring from 30 MHz to 1 GHz and 1 MHz for measuring above 1 GHz
- The Transd=Cabel loss +Antenna factor -pre-amplifier factor
- The pre-test have done for the EUT in three axes and found the worst emission at position shown in test setup photos. The worst case data is recorded in the report.

Above 1G

The frequency spectrum above 1 GHz for Transmitter was investigated. All emission not reported are much lower than the prescribed limits. Set the RBW=1MHz,VBW=3MHz for Peak Detector while the RBW=1MHz,VBW=10Hz for Average Detector,Readings are both peak and average values. The pre-test have done for the EUT in three axes and found the worst emission at position shown in test setup photos.

Company	Jetlun(ShenZhen)Corporation	Test Date	05/06/2011
Test Mode	AC POWER MODE 2405MHz	Detector Function	Peak(PK)/Average(AV)
Product Name	Zigbee Occupancy sensor	Test By	Eric Zhang
Model Name	RD77760	TEMP&Humidity	25°C, 55%

ANTENNA POLARITY & TEST DISTANCE: HORIZONTAL AT 3 M

No.	Frequency (MHz)	Emission Level (dBuV/m)		Limit (dBuV/m)	Margin (dB)	Antenna Height (m)	Table Angle (Degree)	Raw Value (dBuV)	Antenna Factor (dB/m)	Cable Factor (dB)	Pre-amplifier (dB)	Correction Factor (dB/m)
1	*2405.00	87.39	PK			1.00	23	90.79	28.3	4.90	-36.6	-3.40
1	*2405.00	85.31	AV			1.00	23	88.71	28.3	4.90	-36.6	-3.40
2	4810.00	50.25	PK	74.00	23.75	1.00	114	47.05	32.7	7.00	-36.5	3.20
2	4810.00	--	AV	54.00	--	1.00	114	--	32.7	7.00	-36.5	3.20
3	7215.00	53.02	PK	74.00	20.98	1.00	218	43.62	35.8	8.90	-35.3	9.40
3	7215.00	--	AV	54.00	--	1.00	218	--	35.8	8.90	-35.3	9.40
4	9620.00	55.93	PK	74.00	18.07	1.00	320	43.33	37.2	10.20	-34.8	12.60
4	9620.00	46.41	AV	54.00	7.59	1.00	320	33.81	37.2	10.20	-34.8	12.60

ANTENNA POLARITY & TEST DISTANCE: VERTICAL AT 3 M

No.	Frequency (MHz)	Emission Level (dBuV/m)		Limit (dBuV/m)	Margin (dB)	Antenna Height (m)	Table Angle (Degree)	Raw Value (dBuV)	Antenna Factor (dB/m)	Cable Factor (dB)	Pre-amplifier (dB)	Correction Factor (dB/m)
1	*2405.00	90.94	PK			1.0	335	94.3	28.3	4.90	-36.6	-3.40
1	*2405.00	88.85	AV			1.0	335	92.2	28.3	4.90	-36.6	-3.40
2	4810.00	51.31	PK	74.00	22.69	1.0	178	48.1	32.7	7.00	-36.5	3.20
2	4810.00	--	AV	54.00	--	1.0	178	--	32.7	7.00	-36.5	3.20
3	7215.00	53.85	PK	74.00	20.15	1.0	265	44.4	35.8	8.90	-35.3	9.40
3	7215.00	--	AV	54.00	--	1.0	265	--	35.8	8.90	-35.3	9.40
4	9620.00	56.82	PK	74.00	17.18	1.0	98	44.2	37.2	10.20	-34.8	12.60
4	9620.00	46.82	AV	54.00	7.18	1.0	98	34.2	37.2	10.20	-34.8	12.60

REMARKS:

1. Emission level (dBuV/m) =Raw Value (dBuV) + Correction Factor (dB/m)
2. Correction Factor (dB/m) = Antenna Factor (dB/m) + Cable Factor (dB) -Pre-amplifier Factor
3. The other emission levels were very low against the limit.
4. Margin value = Limit value- Emission level.
5. The limit value is defined as per 15.247
6. "*" "": Fundamental frequency
7. The worst test mode is AC power mode and the data is recorded. The average measurement was not performed when the peak measured data under the limit of average detection.

Company	Jetlun(ShenZhen)Corporation	Test Date	05/06/2011
Test Mode	AC POWER MODE 2440MHz	Detector Function	Peak(PK)/Average(AV)
Product Name	Zigbee Occupancy sensor	Test By	Eric Zhang
Model Name	RD77760	TEMP&Humidity	25°C, 55%

ANTENNA POLARITY & TEST DISTANCE: HORIZONTAL AT 3 M

No.	Frequency (MHz)	Emission Level (dBuV/m)		Limit (dBuV/m)	Margin (dB)	Antenna Height (m)	Table Angle (Degree)	Raw Value (dBuV)	Antenna Factor (dB/m)	Cable Factor (dB)	Pre-amplifier (dB)	Correction Factor (dB/m)
1	*2440.00	86.16	PK			1.00 H	115	89.36	28.3	5.10	-36.6	-3.20
1	*2440.00	84.06	AV			1.00 H	115	87.26	28.3	5.10	-36.6	-3.20
2	4880.00	52.64	PK	74.00	21.36	1.00 H	80	49.24	32.3	7.60	-36.5	3.40
2	4880.00	--	AV	54.00	--	1.00 H	80	--	32.3	7.60	-36.5	3.40
3	7320.00	55.14	PK	74.00	18.86	1.00 H	196	45.74	36.1	8.60	-35.3	9.40
3	7320.00	46.32	AV	54.00	7.68	1.00 H	196	36.92	36.1	8.60	-35.3	9.40
4	9760.00	60.09	PK	74.00	13.91	1.00 H	257	47.49	37.2	10.20	-34.8	12.60
4	9760.00	49.36	AV	54.00	4.64	1.00 H	257	36.76	37.2	10.20	-34.8	12.60

ANTENNA POLARITY & TEST DISTANCE: VERTICAL AT 3 M

No.	Frequency (MHz)	Emission Level (dBuV/m)		Limit (dBuV/m)	Margin (dB)	Antenna Height (m)	Table Angle (Degree)	Raw Value (dBuV)	Antenna Factor (dB/m)	Cable Factor (dB)	Pre-amplifier (dB)	Correction Factor (dB/m)
1	*2440.00	91.09	PK			1.00 V	121	94.29	28.3	5.10	-36.6	-3.20
1	*2440.00	87.68	AV			1.00 V	121	90.88	28.3	5.10	-36.6	-3.20
2	4880.00	49.57	PK	74.00	24.43	1.00 V	136	46.17	32.3	7.60	-36.5	3.40
2	4880.00	--	AV	54.00	--	1.00 V	136	--	32.3	7.60	-36.5	3.40
3	7320.00	54.60	PK	74.00	19.40	1.00 V	260	45.2	36.1	8.60	-35.3	9.40
3	7320.00	45.32	AV	54.00	8.68	1.00 V	260	35.92	36.1	8.60	-35.3	9.40
4	9760.00	56.94	PK	74.00	17.06	1.00 V	322	44.34	37.2	10.20	-34.8	12.60
4	9760.00	47.32	AV	54.00	6.68	1.00 V	322	34.72	37.2	10.20	-34.8	12.60

- REMARKS:**
1. Emission level (dBuV/m)=Raw Value(dBuV) + Correction Factor(dB/m)
 2. Correction Factor (dB/m) = Antenna Factor (dB/m) + Cable Factor (dB) -Pre-amplifier Factor
 3. The other emission levels were very low against the limit.
 4. Margin value = Limit value- Emission level.
 5. The limit value is defined as per 15.247
 6. “* “: Fundamental frequency
 7. The worst test mode is AC power mode and the data is recorded. The average measurement was not performed when the peak measured data under the limit of average detection.

Company	Jetlun(ShenZhen)Corporation	Test Date	05/06/2011
Test Mode	AC POWER MODE 2480MHz	Detector Function	Peak(PK)/Average(AV)
Product Name	Zigbee Occupancy sensor	Test By	Eric Zhang
Model Name	RD77760	TEMP&Humidity	25°C, 55%

ANTENNA POLARITY & TEST DISTANCE: HORIZONTAL AT 3 M

No.	Frequency (MHz)	Emission Level (dBuV/m)		Limit (dBuV/m)	Margin (dB)	Antenna Height (m)	Table Angle (Degree)	Raw Value (dBuV)	Antenna Factor (dB/m)	Cable Factor (dB)	Pre-amplifier (dB)	Correction Factor (dB/m)
1	*2480.00	83.88	PK			1.00	110	87.18	28.2	5.10	36.6	-3.30
1	*2480.00	81.68	AV			1.00	110	84.98	28.2	5.10	36.6	-3.30
2	4960.00	49.69	PK	74.00	24.31	1.00	88	45.89	33.0	7.00	36.2	3.80
2	4960.00	--	AV	54.00	--	1.00	88	--	33.0	7.00	36.2	3.80
3	7340.00	53.42	PK	74.00	20.58	1.00	196	44.02	36.2	8.50	35.3	9.40
3	7340.00	--	AV	54.00	--	1.00	196	--	36.2	8.50	35.3	9.40
4	10721.72	55.46	PK	74.00	18.54	1.00	257	38.86	38.0	11.30	32.7	16.6
4	10721.72	46.05	AV	54.00	7.95	1.00	257	29.45	38.0	11.30	32.7	16.6

ANTENNA POLARITY & TEST DISTANCE: VERTICAL AT 3 M

No.	Frequency (MHz)	Emission Level (dBuV/m)		Limit (dBuV/m)	Margin (dB)	Antenna Height (m)	Table Angle (Degree)	Raw Value (dBuV)	Antenna Factor (dB/m)	Cable Factor (dB)	Pre-amplifier (dB)	Correction Factor (dB/m)
1	*2480.00	88.52	PK			1.00	66	91.82	28.2	5.10	36.6	-3.30
1	*2480.00	86.29	AV			1.00	66	89.59	28.2	5.10	36.6	-3.30
2	4960.00	55.05	PK	74.00	18.95	1.00	146	51.25	36.2	8.50	35.3	3.80
2	4960.00	46.00	AV	54.00	8.00	1.00	146	42.20	36.2	8.50	35.3	3.80
3	7340.00	54.31	PK	74.00	19.69	1.00	312	44.91	37.4	10.10	34.8	9.40
3	7340.00	45.31	AV	54.00	8.69	1.00	312	35.91	37.4	10.10	34.8	9.40
4	10721.72	55.53	PK	74.00	18.47	1.00	125	38.93	38.0	11.30	32.7	16.6
4	10721.72	46.20	AV	54.00	7.80	1.00	125	29.60	38.0	11.30	32.7	16.6

- REMARKS:**
1. Emission level (dBuV/m) = Raw Value (dBuV) + Correction Factor (dB/m)
 2. Correction Factor (dB/m) = Antenna Factor (dB/m) + Cable Factor (dB) - Pre-amplifier Factor
 3. The other emission levels were very low against the limit.
 4. Margin value = Limit value - Emission level.
 5. The limit value is defined as per 15.247
 6. " * " : Fundamental frequency
 7. The worst test mode is AC power mode and the data is recorded. The average measurement was not performed when the peak measured data under the limit of average detection.

4.3. Maximum Peak Output Power

TEST CONFIGURATION

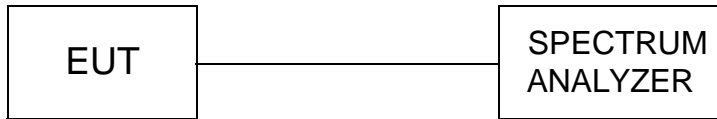

TEST PROCEDURE

Remove the antenna from the EUT and then connect a low loss RF cable from the antenna port to the spectrum. Set the RBW=3MHz VBW=3MHz.

LIMIT

The Maximum Peak Output Power Measurement is 30dBm.

TEST RESULTS

Company	Jetlun(ShenZhen)Corporation	Test Date	05/09/2011
Product Name	Zigbee Occupancy sensor	Test By	Eric Zhang
Model Name	RD77760	TEMP&Humidity	25°C, 55%

AC Power mode:

Channel Frequency (MHz)	Peak Power Output (dBm)	Peak Power Limit (dBm)	Pass / Fail
2405	-1.164	30	PASS
2440	-0.808	30	PASS
2480	0.073	30	PASS

Battery mode:

Channel Frequency (MHz)	Peak Power Output (dBm)	Peak Power Limit (dBm)	Pass / Fail
2405	-1.345	30	PASS
2440	-0.933	30	PASS
2480	0.064	30	PASS

Note: The test results including the cable lose.

Battery Mode:

Low channel

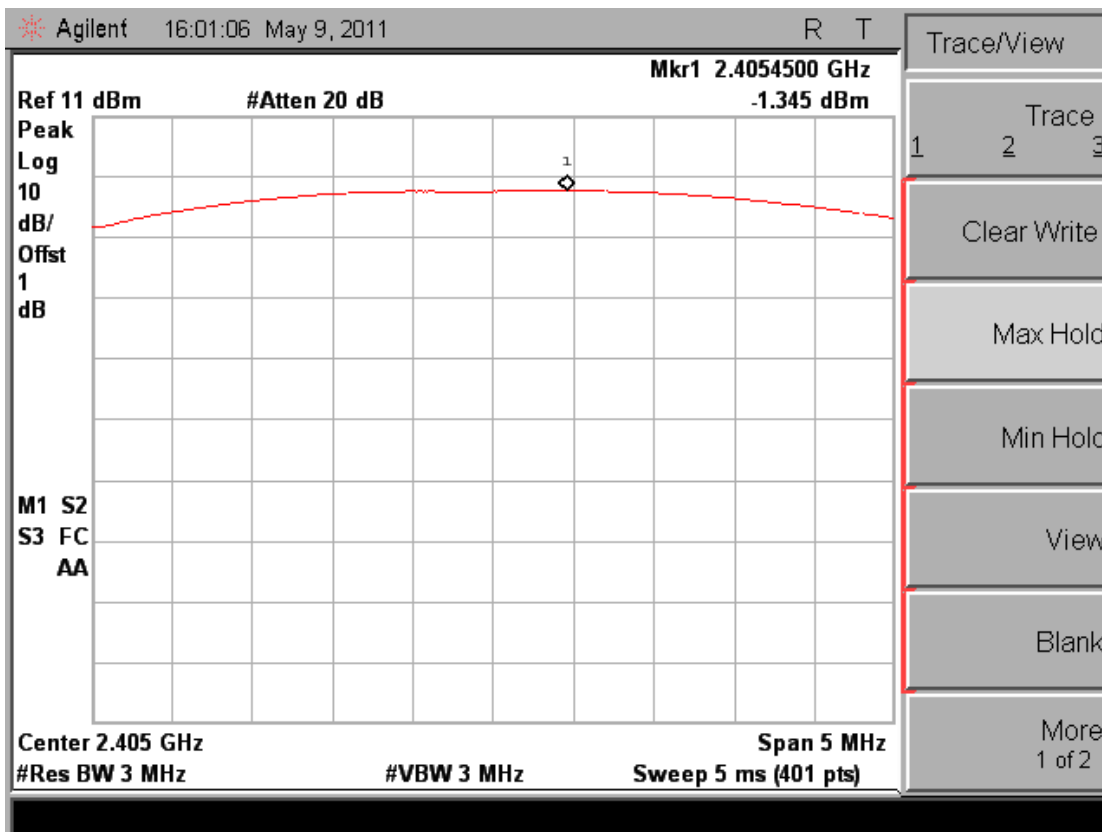

Middle channel

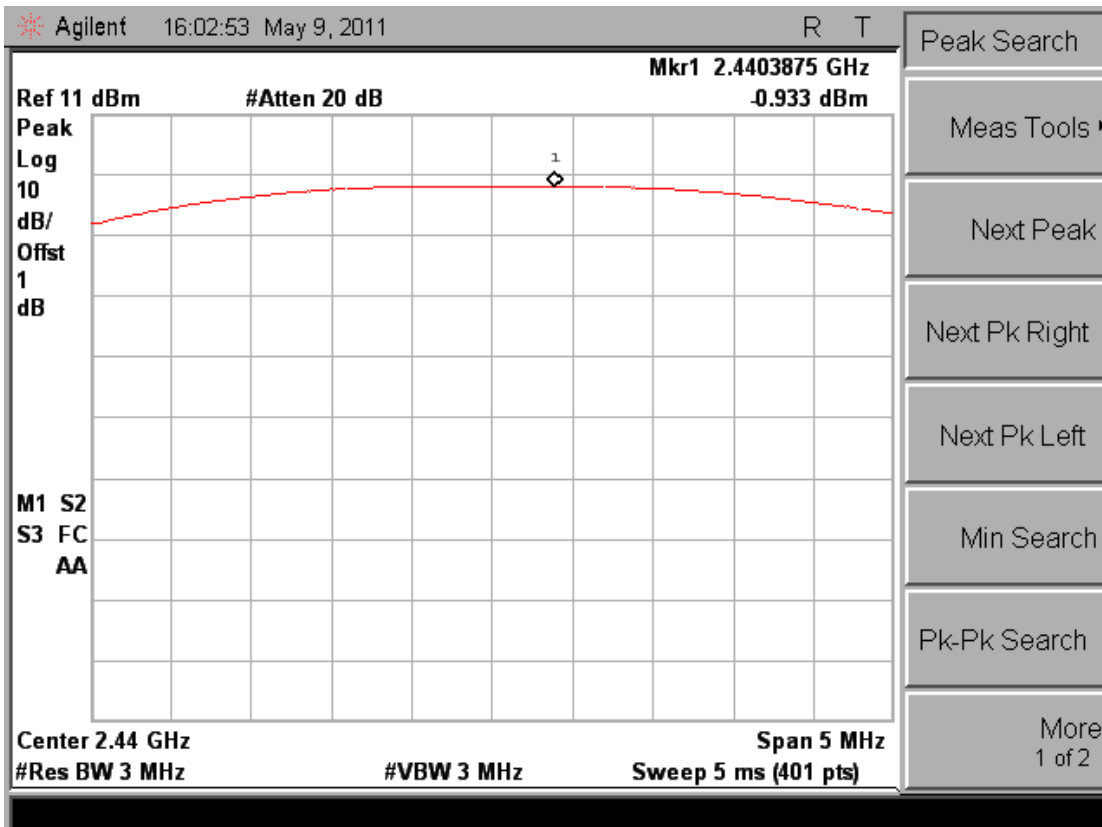

High channel

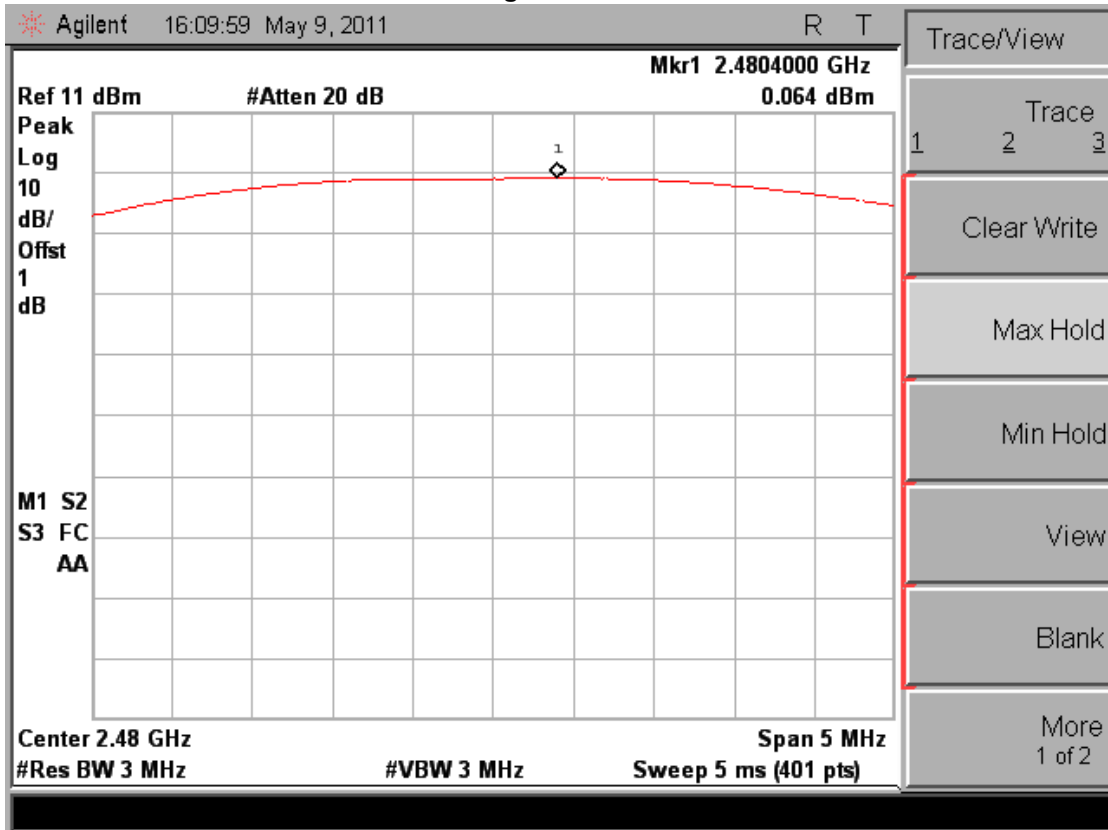

AC Power Mode:

Low channel

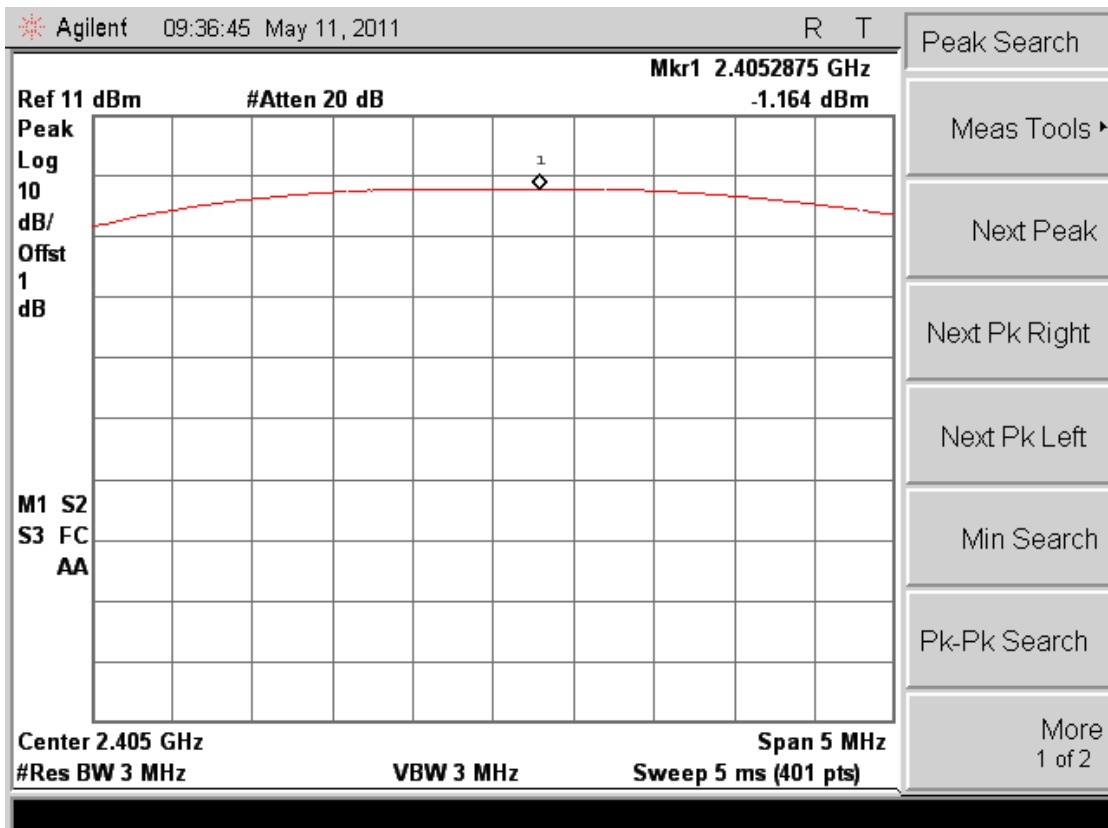

Middle channel

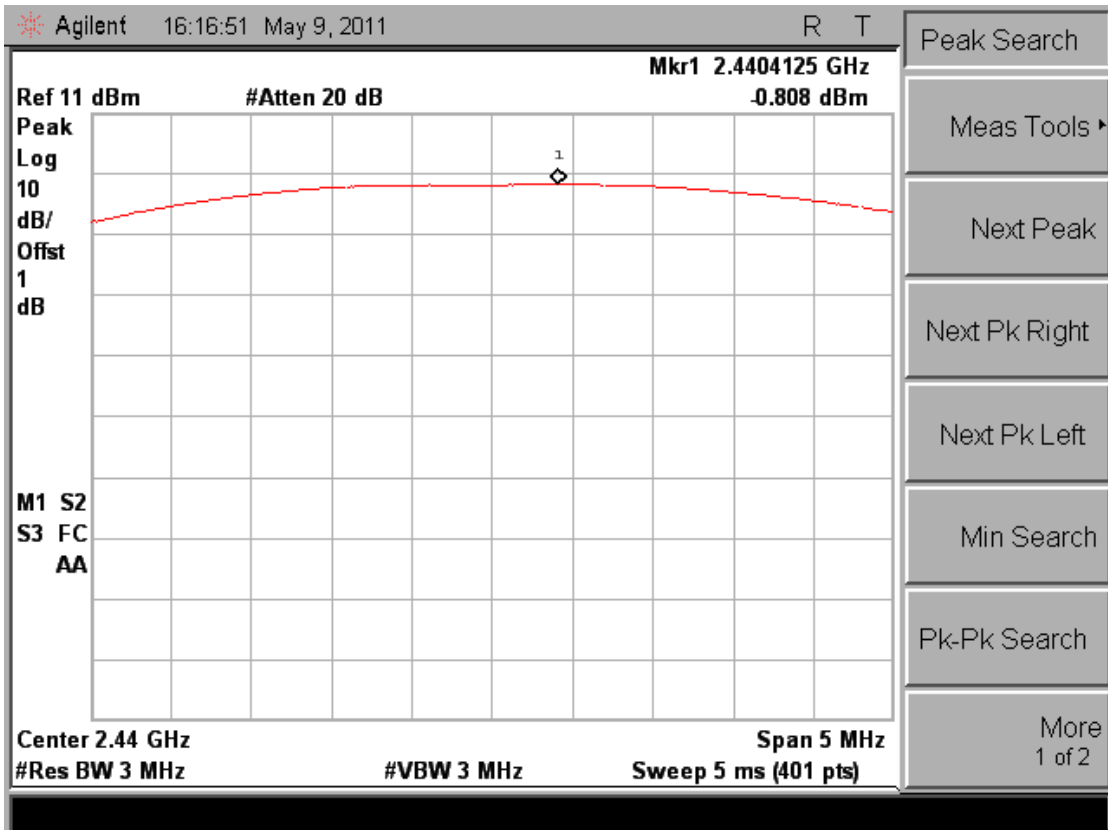

High channel

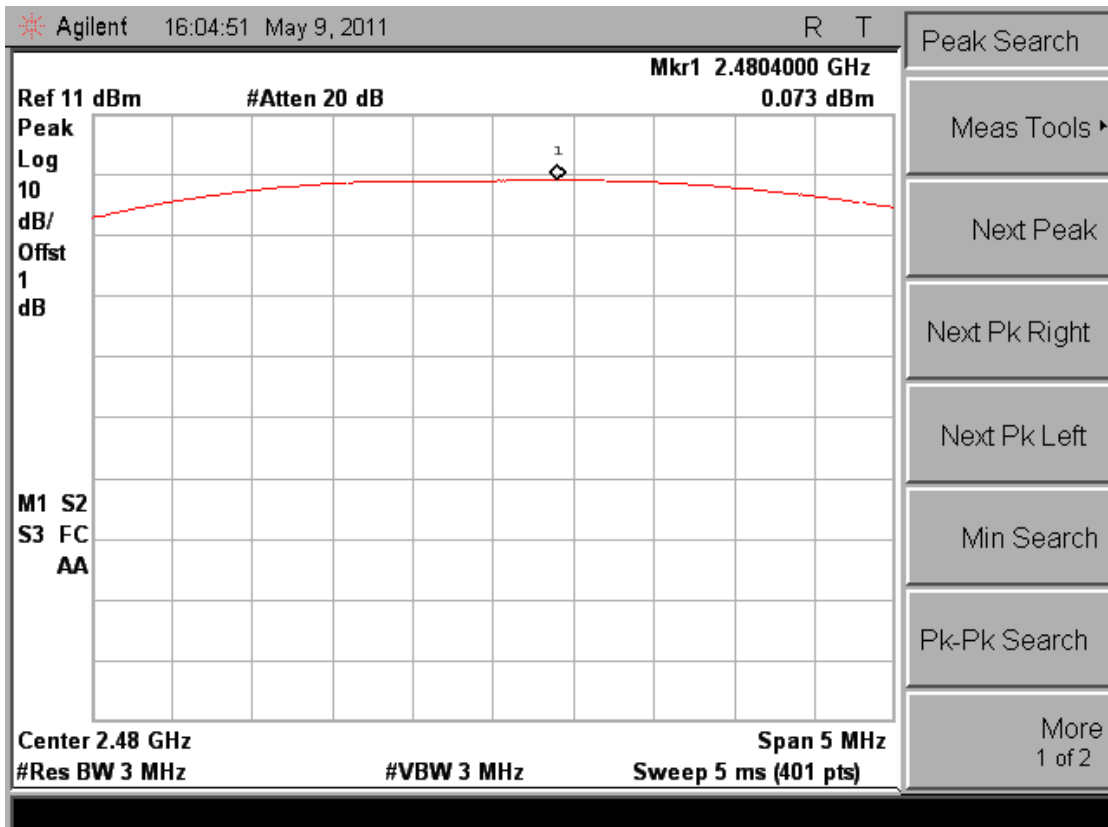

4.4. Power Spectral Density

TEST CONFIGURATION

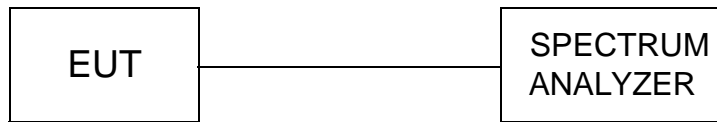

TEST PROCEDURE

1. Set CENTER FREQUENCY = Frequency from Power Spectral Density Test Matrix
2. Set SPAN = 20 MHz (For devices with a nominal 40 MHz BW, 50 MHz span will be needed)
3. Set REFERENCE LEVEL = 20 dBm
4. Set ATTENUATION = 0 dB (add attenuation, if necessary)
5. Set SWEEP TIME = Coupled
6. Set RBW = 3 kHz
7. Set VBW = 10 kHz
8. Set DETECTOR = Peak
9. Set MKR = Center Frequency
10. Set TRACE = CLEAR WRITE

Place the radio in continuous transmit mode. Set the TRACE to MAX HOLD, and after the trace stabilizes, the TRACE to VIEW. Set the marker on the peak of the signal and then adjust the center frequency of the spectrum analyzer to the marker frequency. After viewing the EUT waveform on the spectrum analyzer, perform the following spectrum analyzer functions to capture the trace:

11. Set SPAN = 300 kHz
12. Set SWEEP TIME = 100 s
13. Set TRACE = MAX HOLD
14. Set MKR = PEAK SEARCH
15. Record the marker level for the particular mode. Repeat these steps for other device modes.

LIMIT

For digitally modulated systems, the power spectral density conducted from the intentional radiator to the antenna shall not be greater than 8 dBm in any 3 kHz band during any time interval of continuous transmission.

TEST RESULTS

Company	Jetlun(ShenZhen)Corporation	Test Date	05/09/2011
Product Name	ZigBee Module	Test By	Eric Zhang
Model Name	RD77760	TEMP&Humidity	25°C, 55%

AC Power mode:

CHANNEL NUMBER	CHANNEL FREQUENCY (MHz)	RF POWER LEVEL IN 3 KHz BW (dBm)	MAXIMUM LIMIT (dBm)	PASS/FAIL
11	2405	-14.96	8	PASS
18	2440	-14.29	8	PASS
26	2480	-13.93	8	PASS

Battery mode:

CHANNEL NUMBER	CHANNEL FREQUENCY (MHz)	RF POWER LEVEL IN 3 KHz BW (dBm)	MAXIMUM LIMIT (dBm)	PASS/FAIL
11	2405	-15.60	8	PASS
18	2440	-15.28	8	PASS
26	2480	-14.03	8	PASS

Note: The test results including the cable lose.

Photos of Power Spectral Density Measurement (AC Power mode)

Low Channel

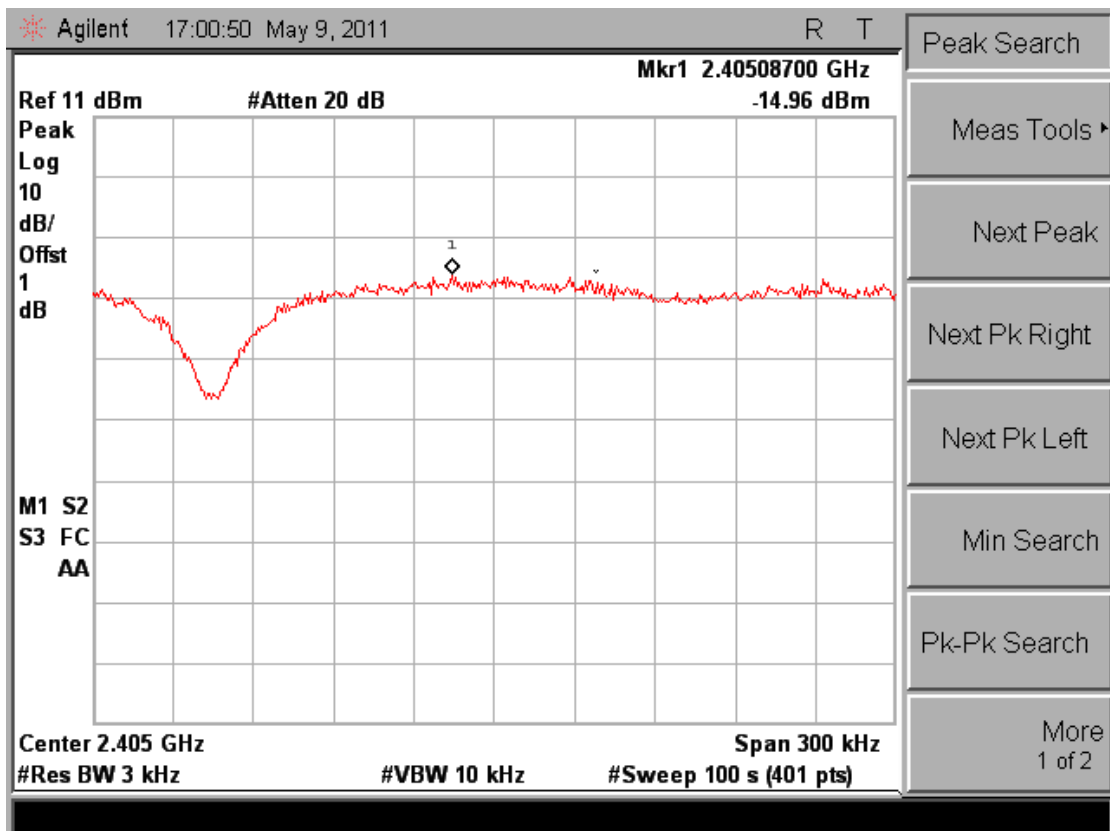

Middle Channel

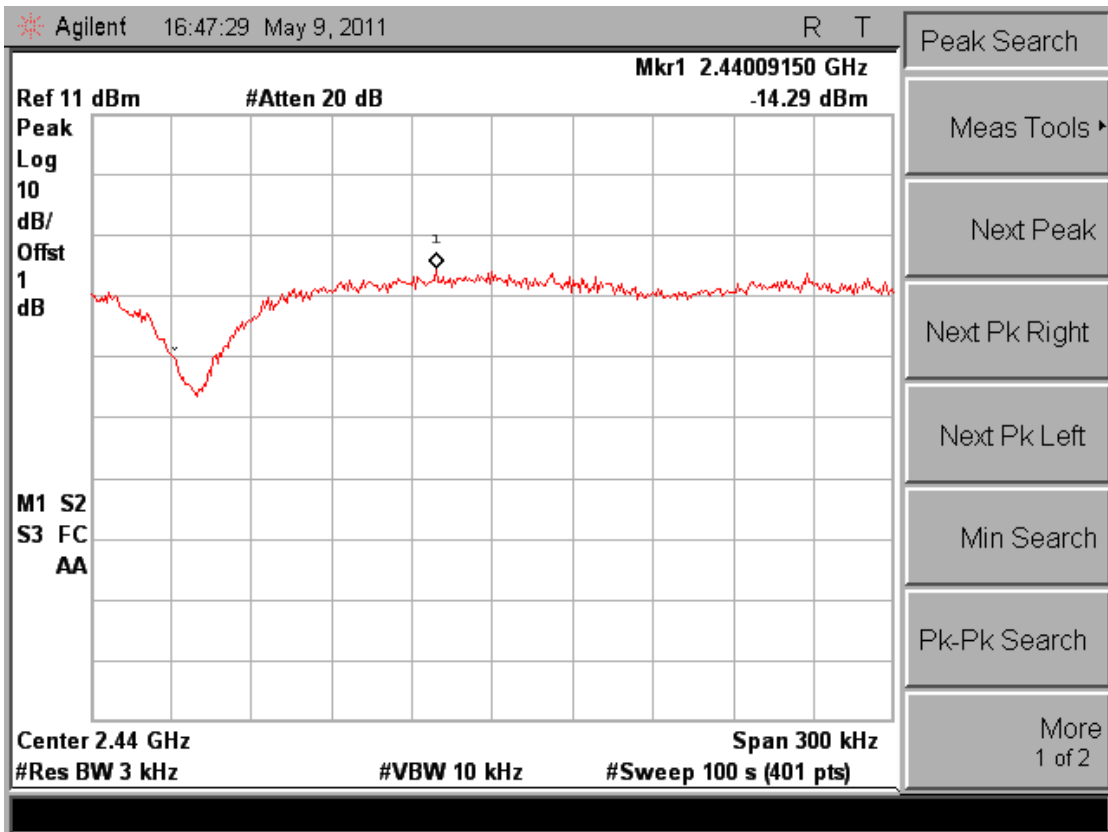

High Channel

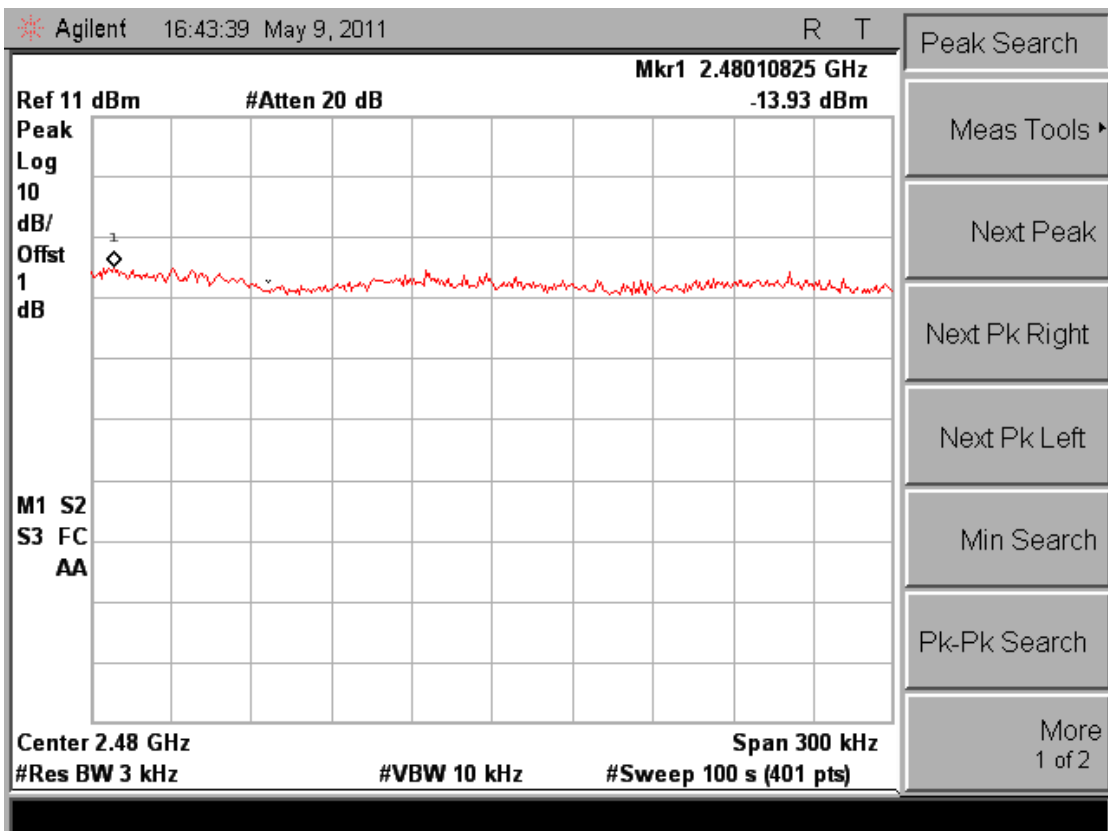

Photos of Power Spectral Density Measurement (Battery mode)

Low Channel

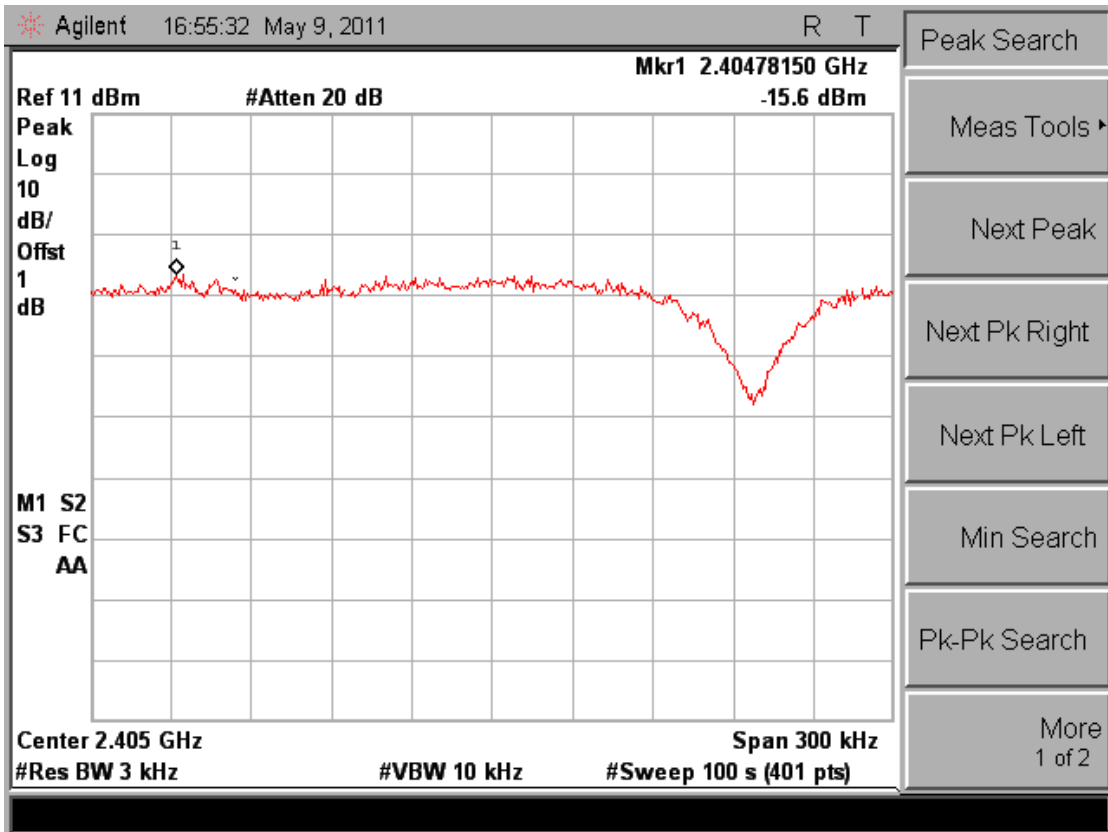

Middle Channel

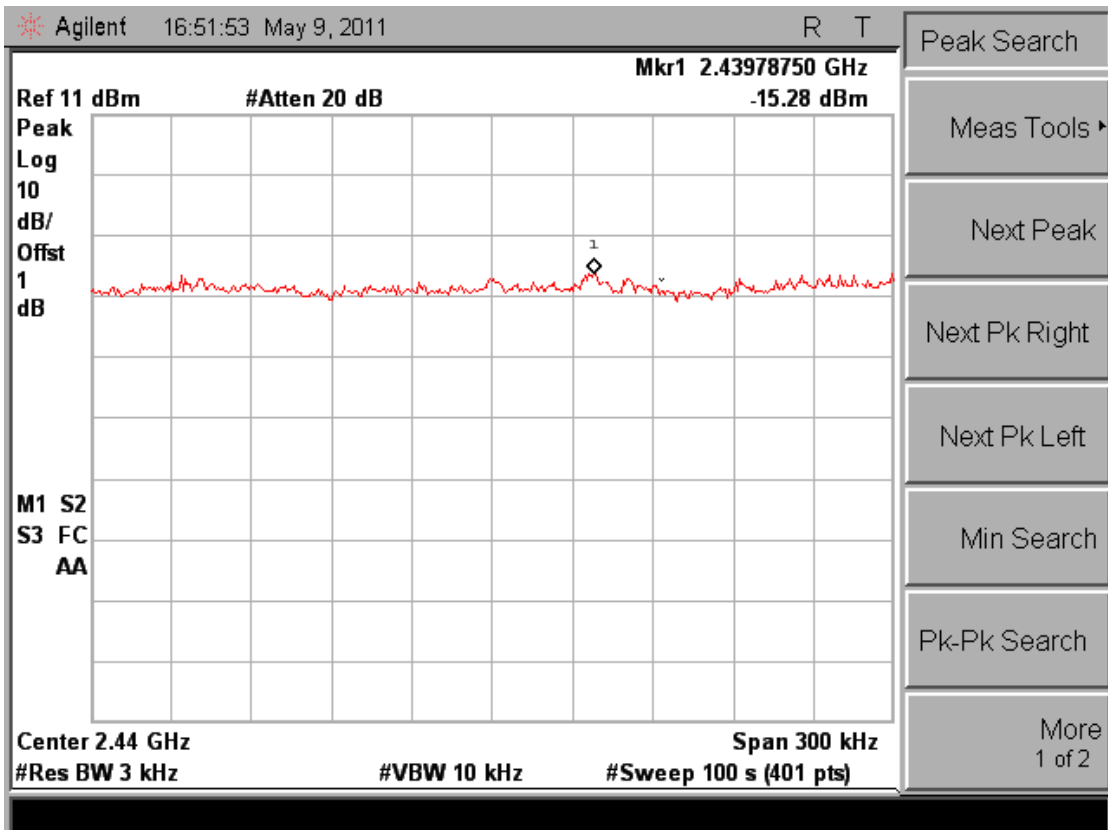

High Channel

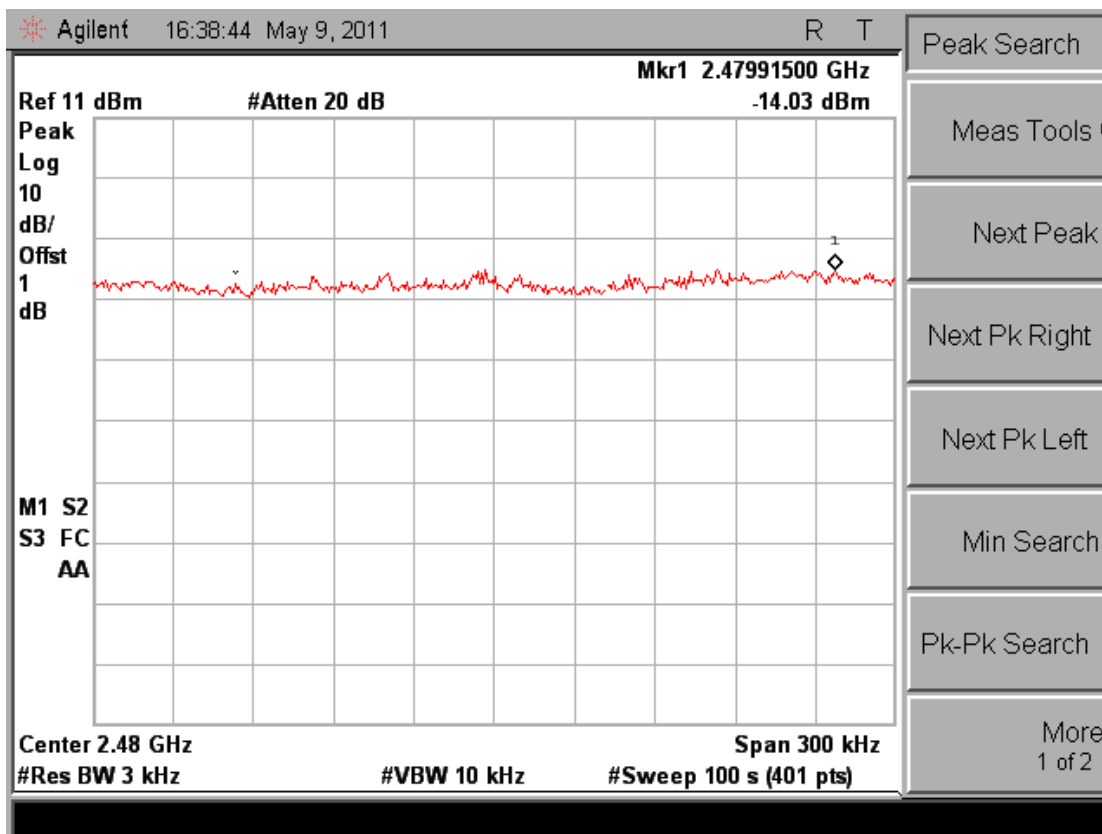

4.5. Band Edge Compliance of RF Emission

TEST CONFIGURATION

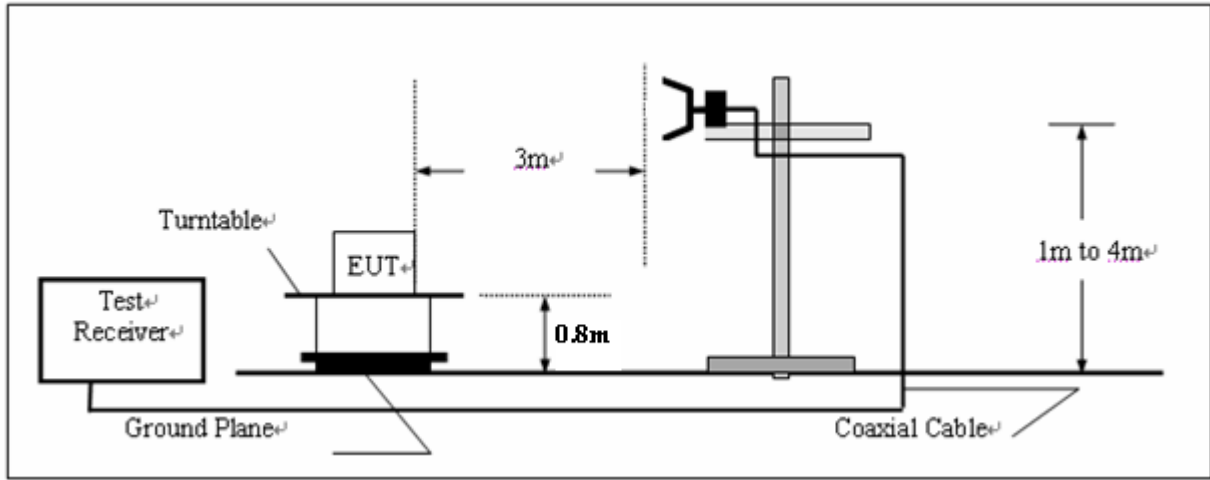

TEST PROCEDURE

The band edge compliance of RF radiated emission should be measured by following the guidance in ANSI C63.10:2009 with respect to maximizing the emission by rotating the EUT, measuring the emission while the EUT is situated in three orthogonal planes (if appropriate), adjusting the measurement antenna height and polarization etc. Set RBW=1MHz and VBM= 3MHz to measure the peak field strength and set RBW to 1MHz and VBW to 10Hz to measure the average radiated field strength.

LIMIT

Fall in the restricted bands listed in section 15.205. The maximum permitted average field strength is listed in section 15.209(see Section 15.205(c)).

Frequency (MHz)	Limit Average (dBuV/m)	Limit Peak (dBuV/m)
Below 2390 or Above 2483.5	54	74

TEST RESULTS

Photos of Band Edge Measurement (AC Power Mode)

Low Channel worst case: AC Power Mode Polarity: Ver.

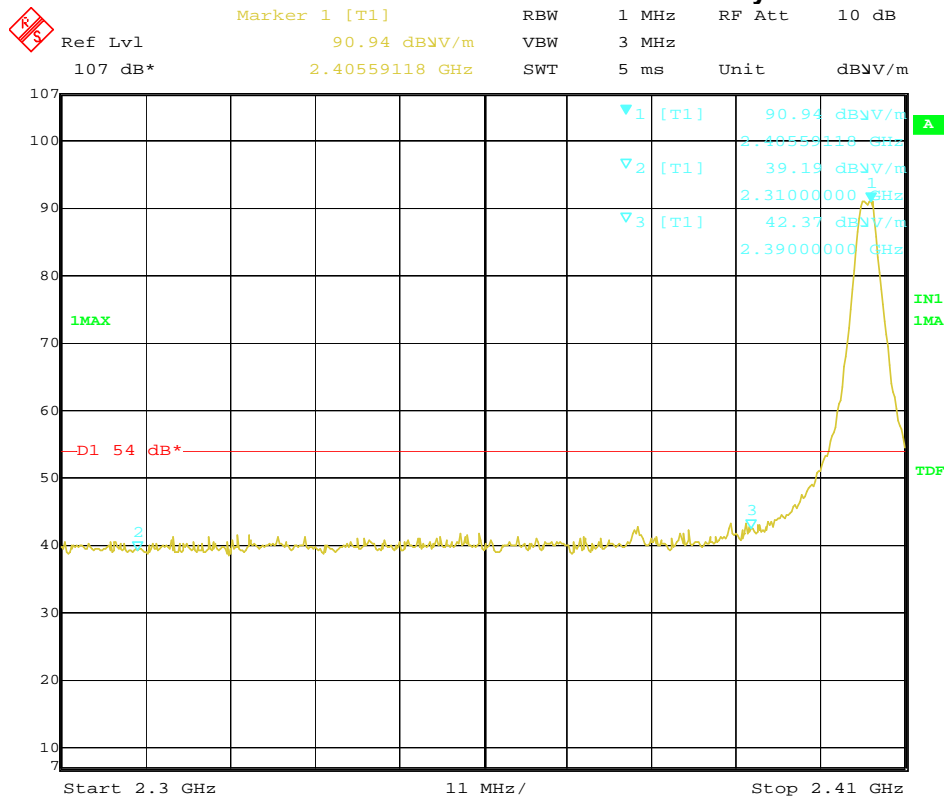

Date: 6.MAY.2011 19:25:52

High Channel worst case: AC Power Mode Polarity: Ver.

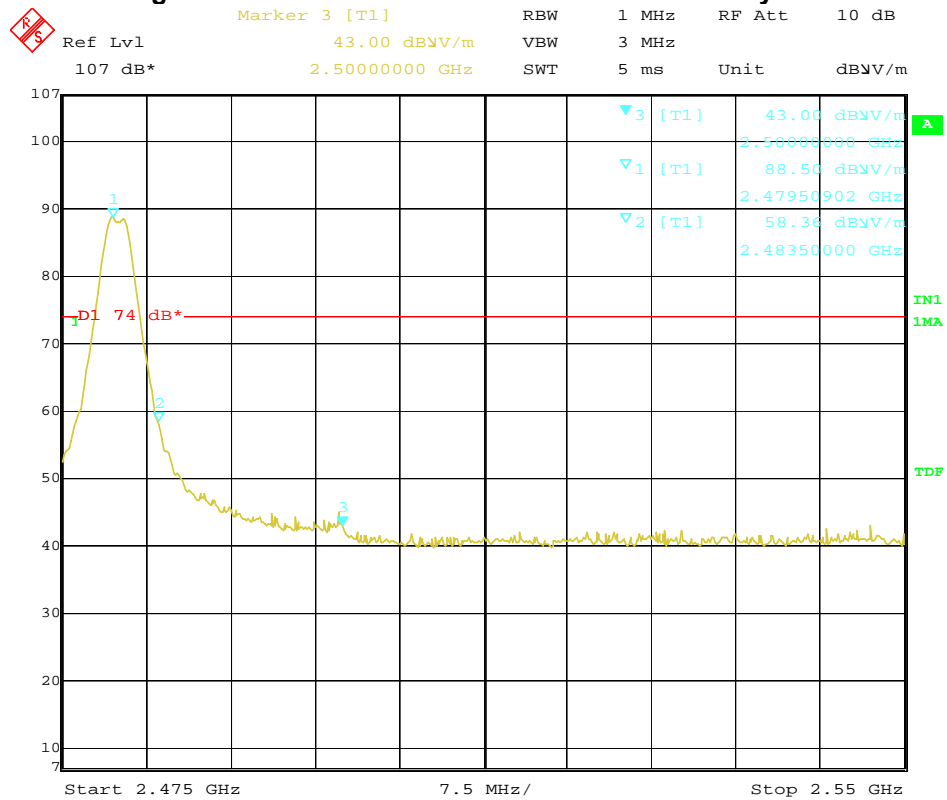

Date: 6.MAY.2011 19:45:50

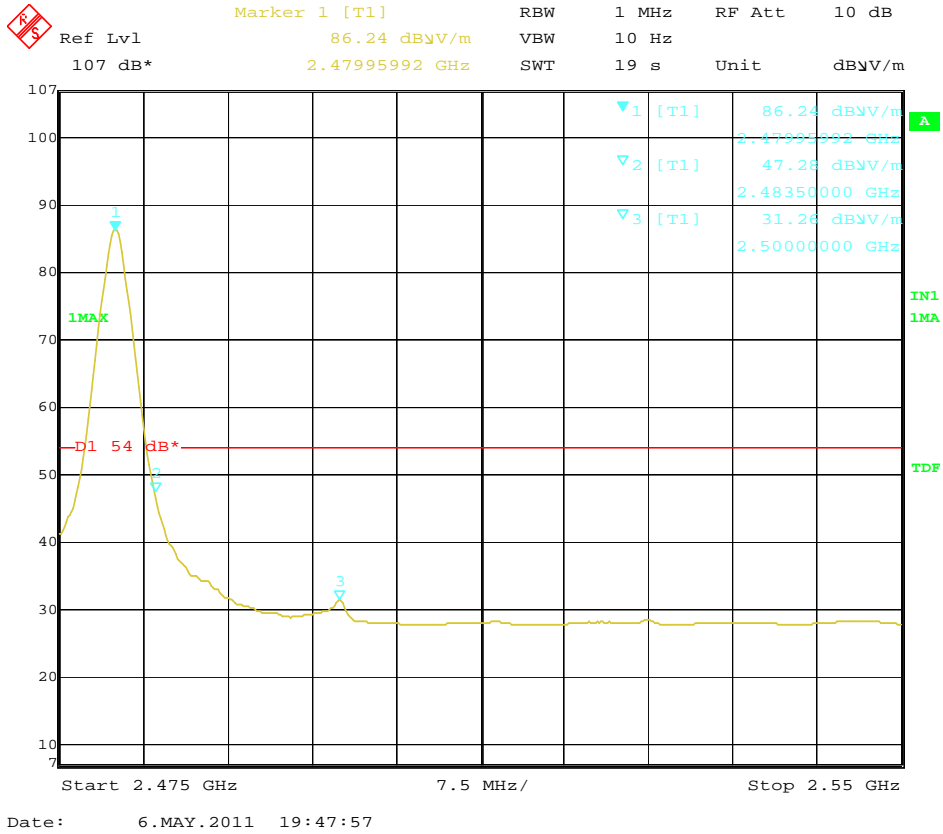

- Note : 1.The average measurement was not performed when the peak measured data under the limit of average detection.
- 2.The pre-test have done for both polarization and found the worst emission at Vertical.The worst case data is recorded.
3. The worst test mode is AC power mode.

4.6. Spurious RF Conducted Emission

TEST CONFIGURATION

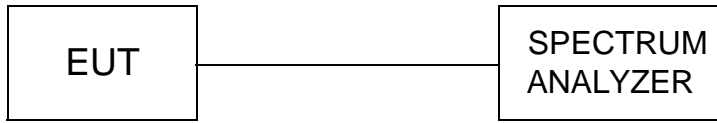

TEST PROCEDURE

The unlicensed wireless device antenna port connected to the spectrum analyzer, If a second antenna port is available, it shall be tested at one frequency to verify it has similar output characteristics as the fully-tested port. Set the spectrum RBW=100KHz, RBW=300KHz.

LIMIT

The radio frequency power that is produced by the intentional radiator shall be at least 20 dB below that in the 100 kHz bandwidth within the band that contains the highest level of the desired power.

TEST RESULTS

Photo of Spurious RF Conducted Emission Measurement(Worst case: AC Power Mode)

Low channel

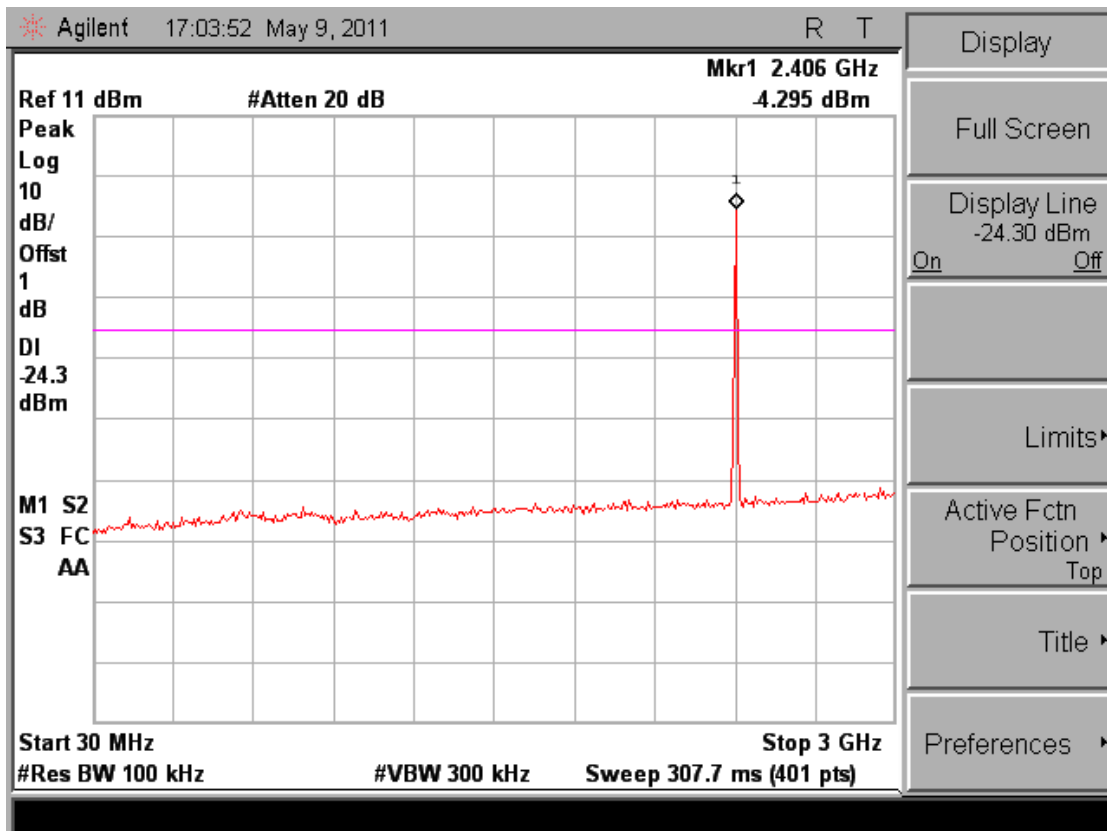

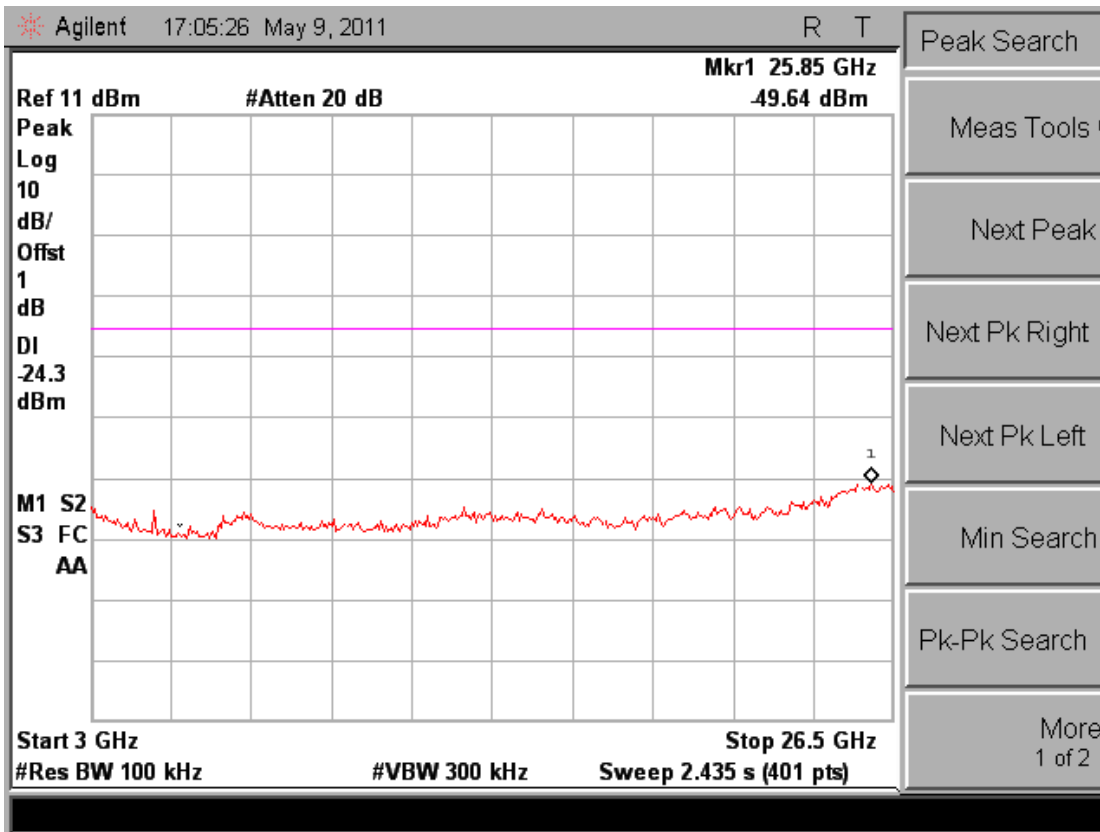

Middle Channel

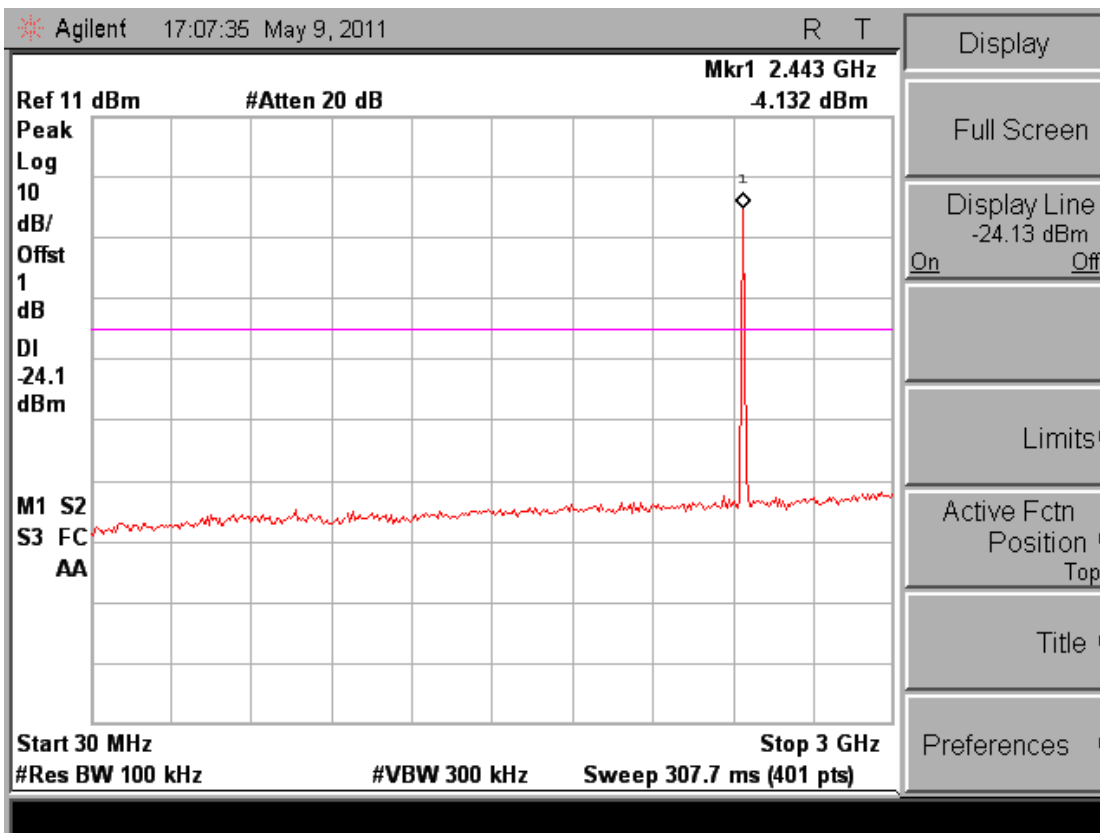

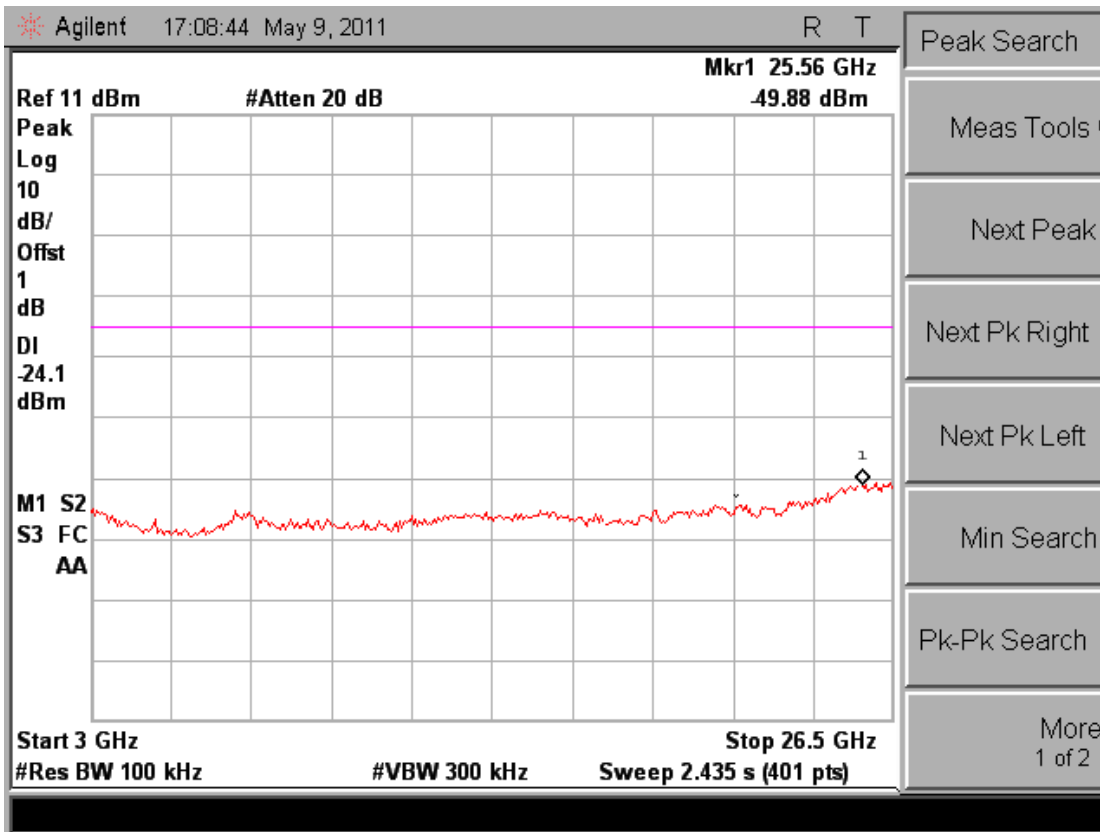

High channel

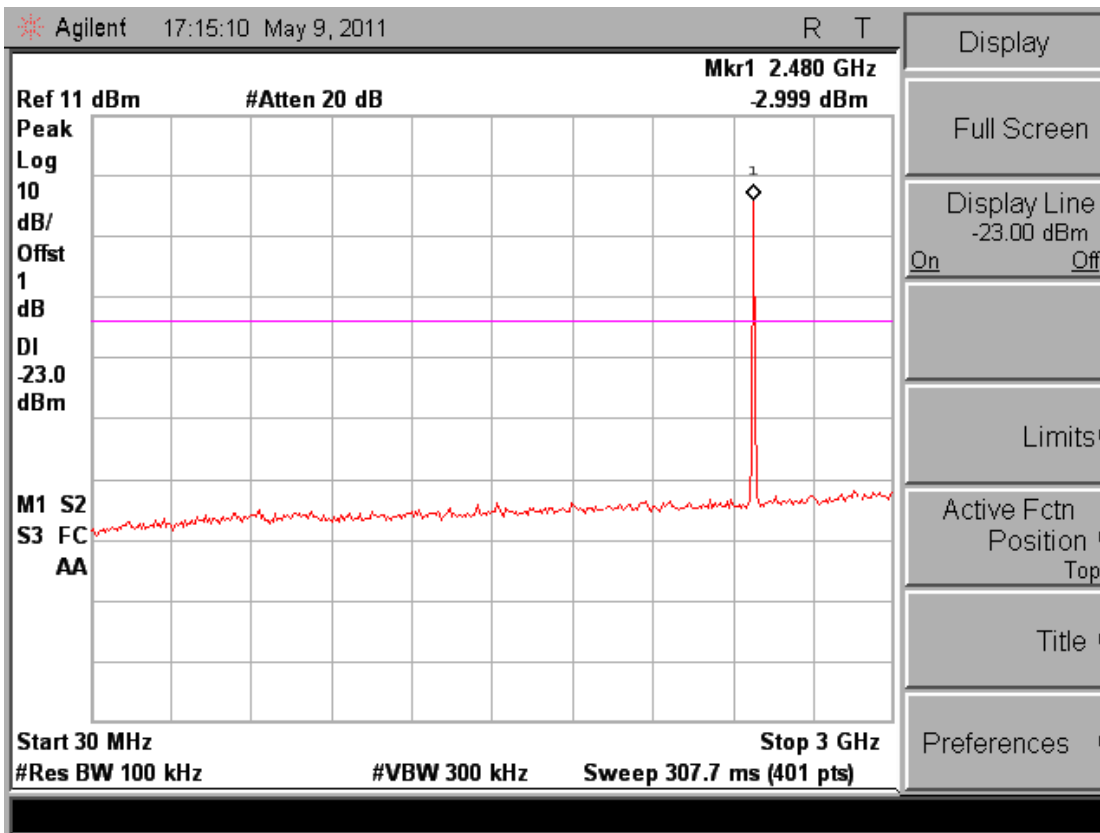

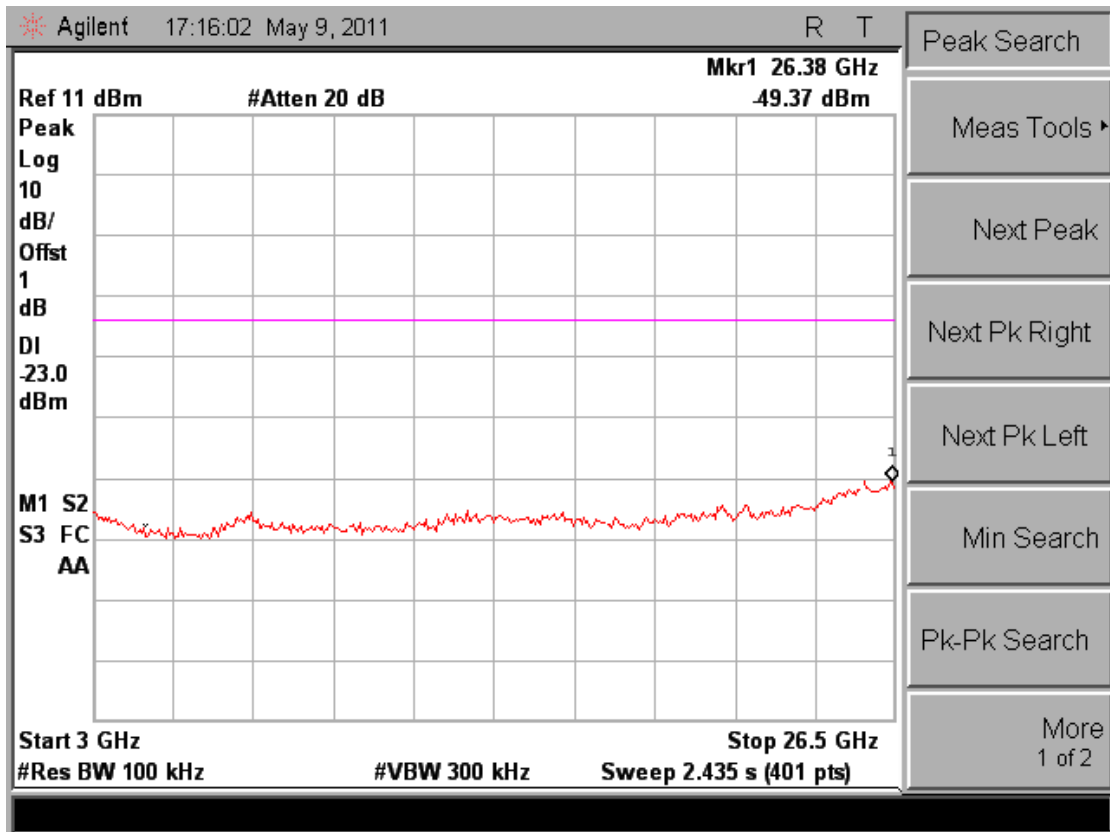

Note : The worst test mode is AC power mode .

Frequency	Delta peak to band emission	Limit(dBc)
2400MHz	42.206	20
2483.5MHz	43.566	20

Low channel

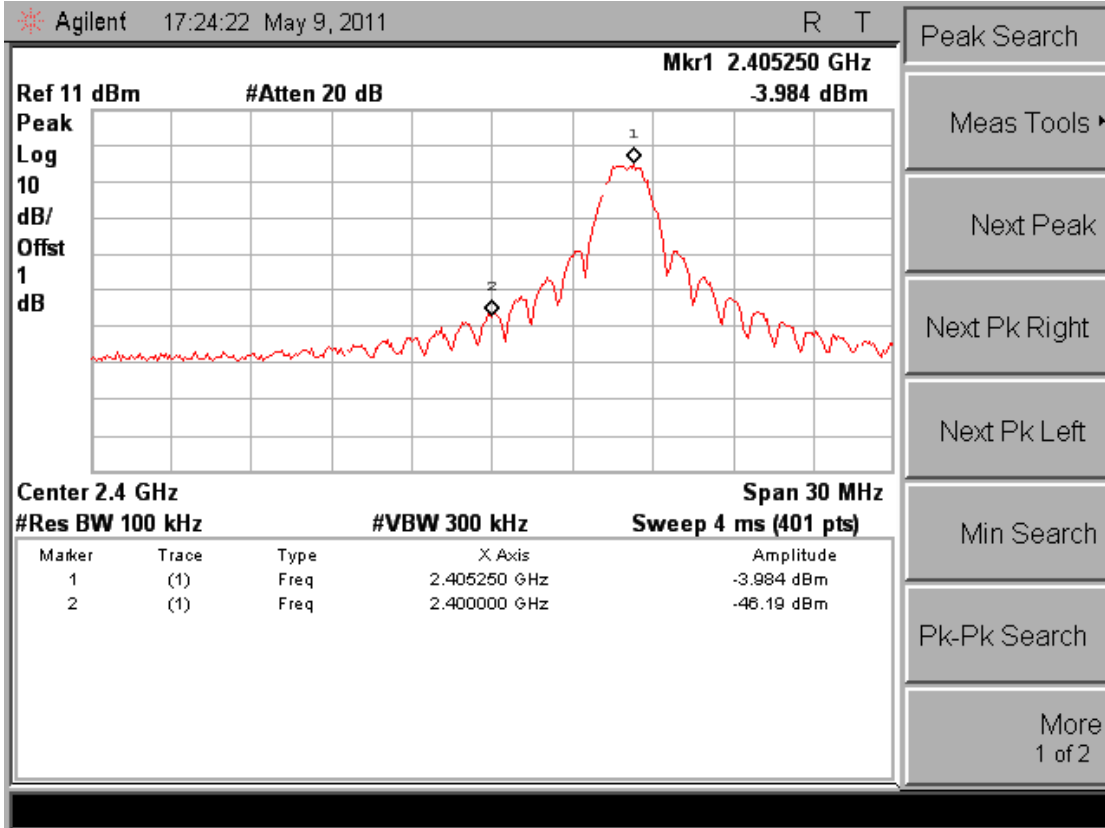

High channel

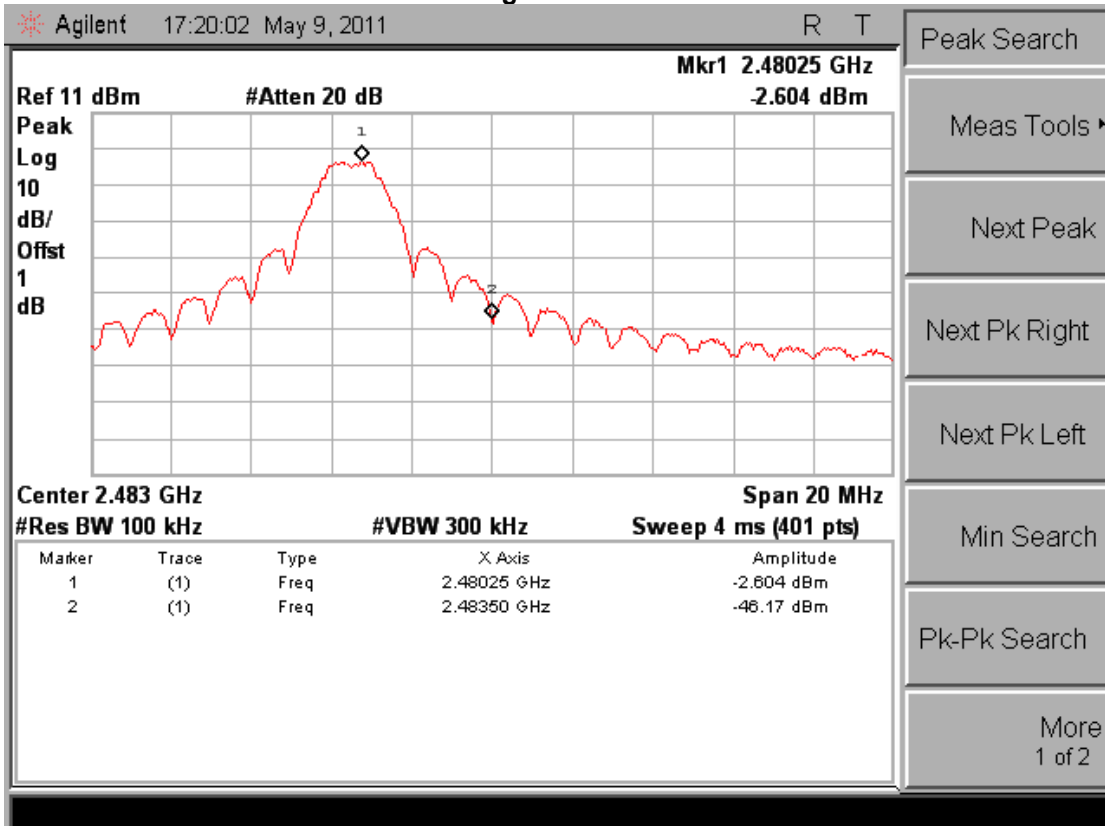

4.7. 6dB Bandwidth

TEST CONFIGURATION

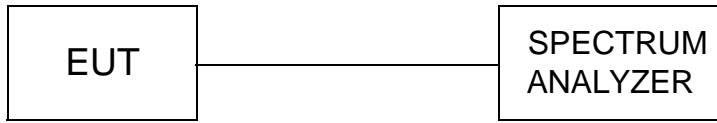

TEST PROCEDURE

The transmitter output was connected to the spectrum analyzer through an attenuator. The bandwidth of the fundamental frequency was measured by spectrum analyzer with 100 KHz RBW and 300KHz VBW.

The 6dB bandwidth is defined as the total spectrum the power of which is higher than peak power minus 6dB.

LIMIT

For digital modulation systems, the minimum 6 dB bandwidth shall be at least 500 kHz.

TEST RESULTS

Company	Jetlun(ShenZhen)Corporation	Test Date	05/09/2011
Product Name	ZigBee Module	Test By	Eric Zhang
Model Name	RD77760	TEMP&Humidity	25°C, 55%

AC Power mode

CHANNEL	CHANNEL FREQUENCY (MHz)	6 dB BANDWIDTH (MHz)	MINIMUM LIMIT (MHz)	PASS/FAIL
11	2405	1.578	0.5	PASS
18	2440	1.567	0.5	PASS
26	2480	1.563	0.5	PASS

Battery mode

CHANNEL	CHANNEL FREQUENCY (MHz)	6 dB BANDWIDTH (MHz)	MINIMUM LIMIT (MHz)	PASS/FAIL
11	2405	1.553	0.5	PASS
18	2440	1.563	0.5	PASS
26	2480	1.553	0.5	PASS

Photos of 6dB Bandwidth Measurement (AC Power mode)

Low Channel

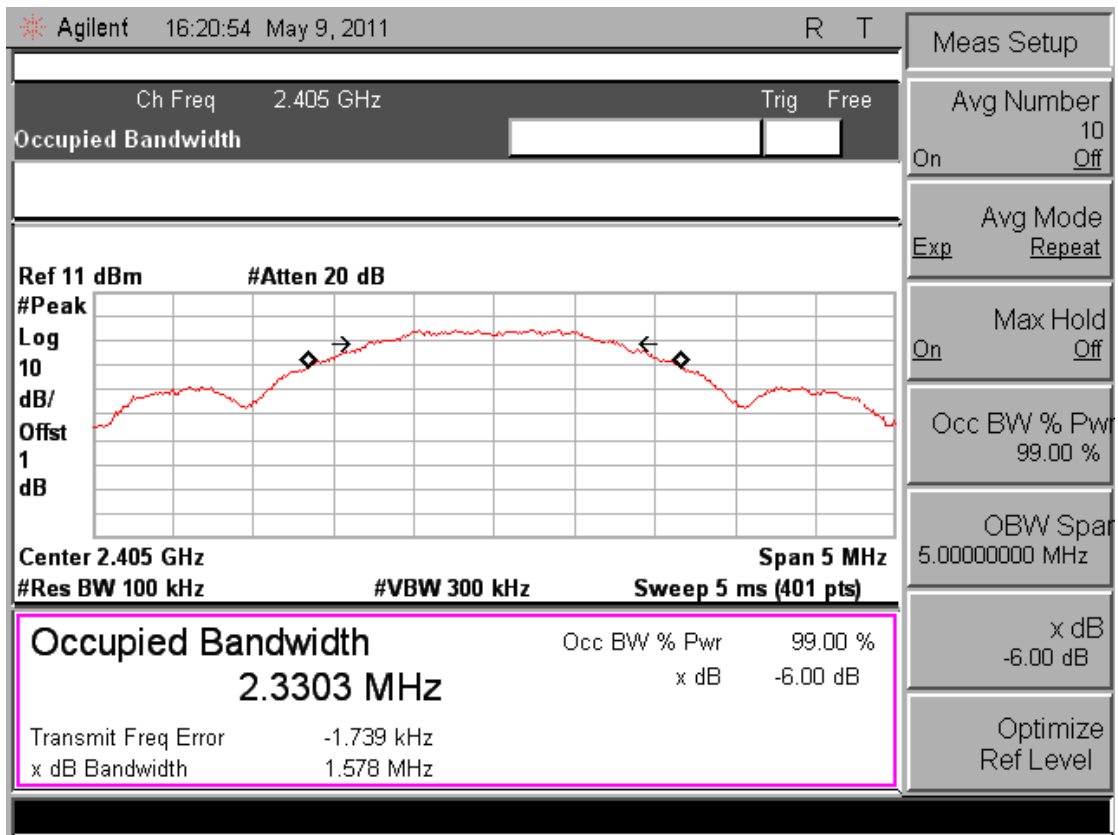

Middle Channel

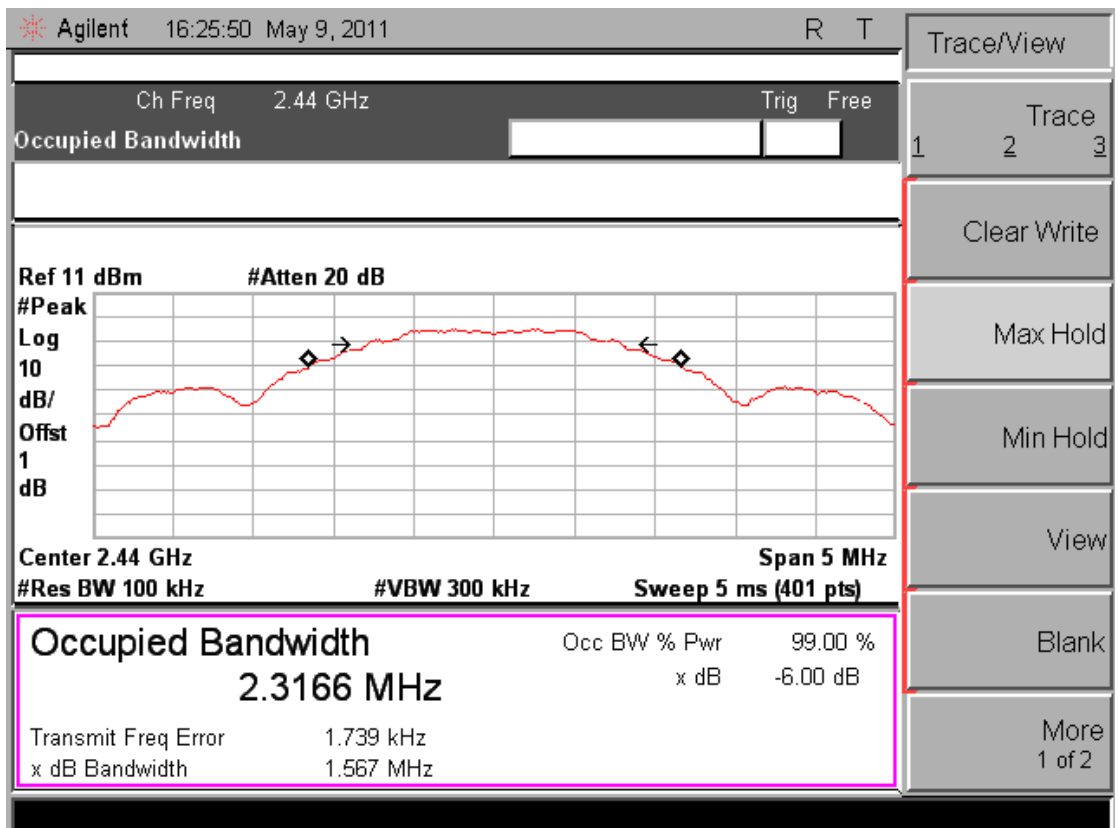

High Channel

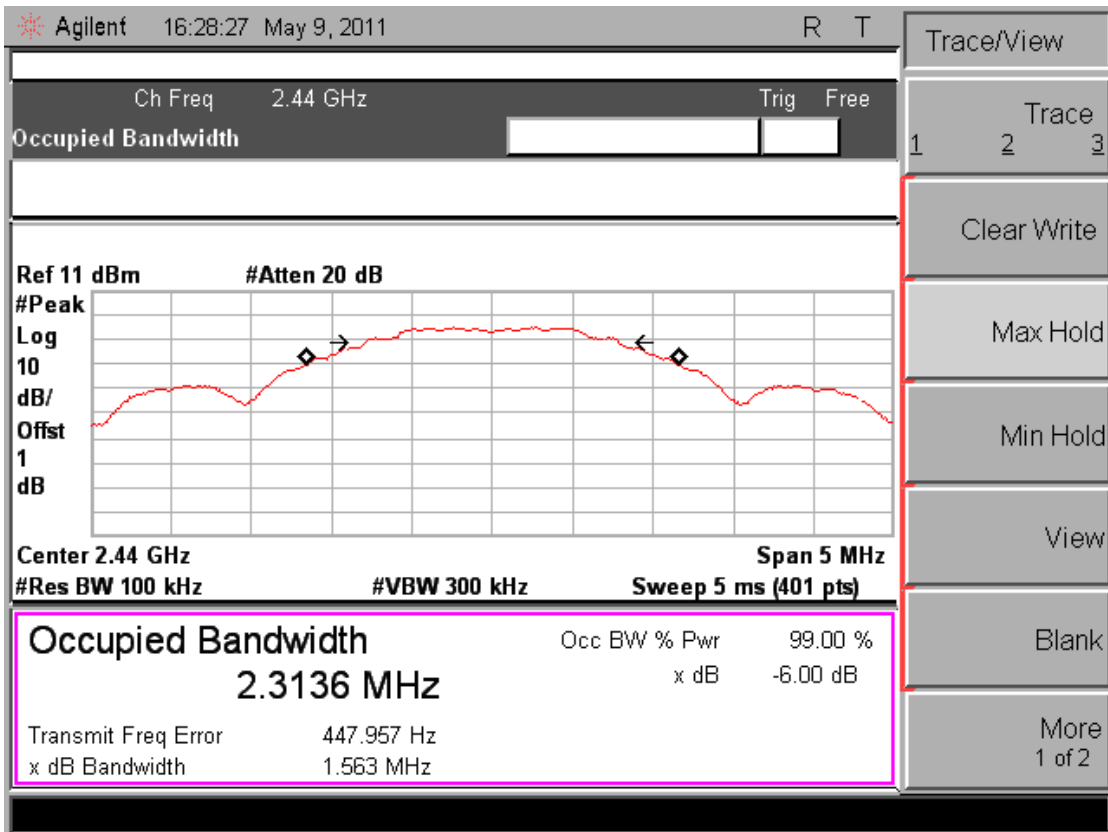

Photos of 6dB Bandwidth Measurement (Battery mode)

Low Channel

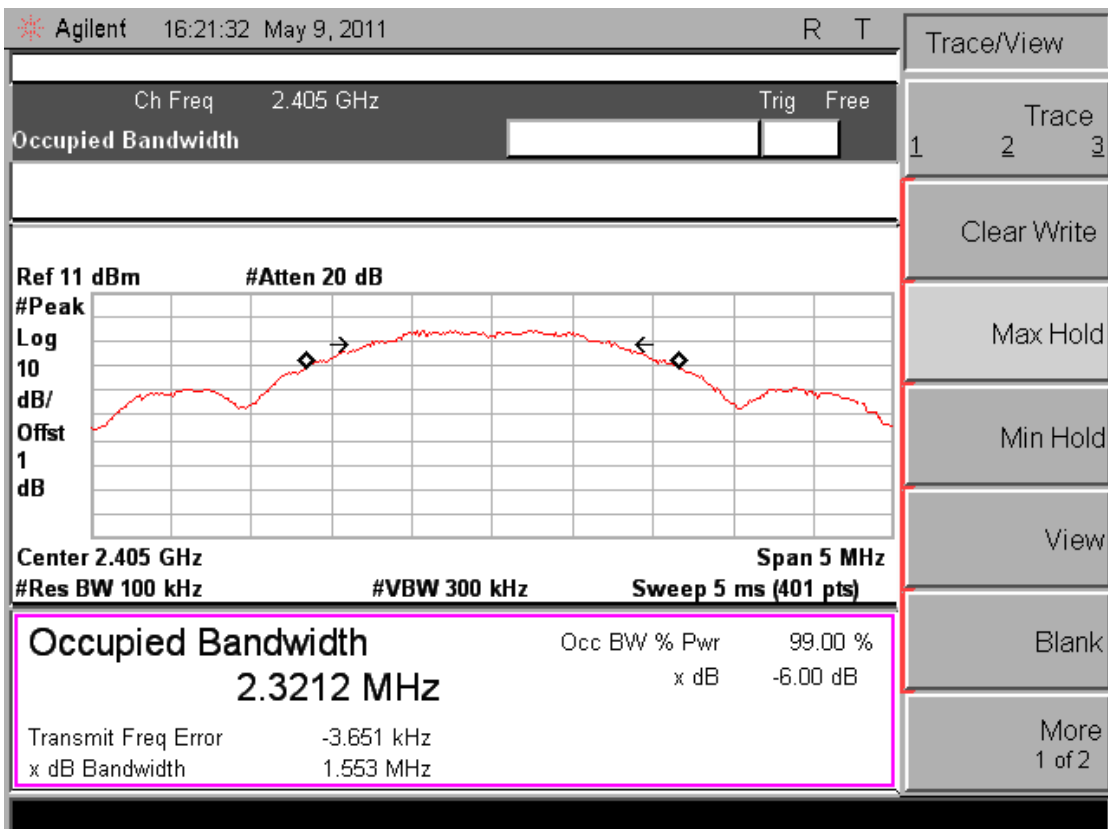

Middle Channel

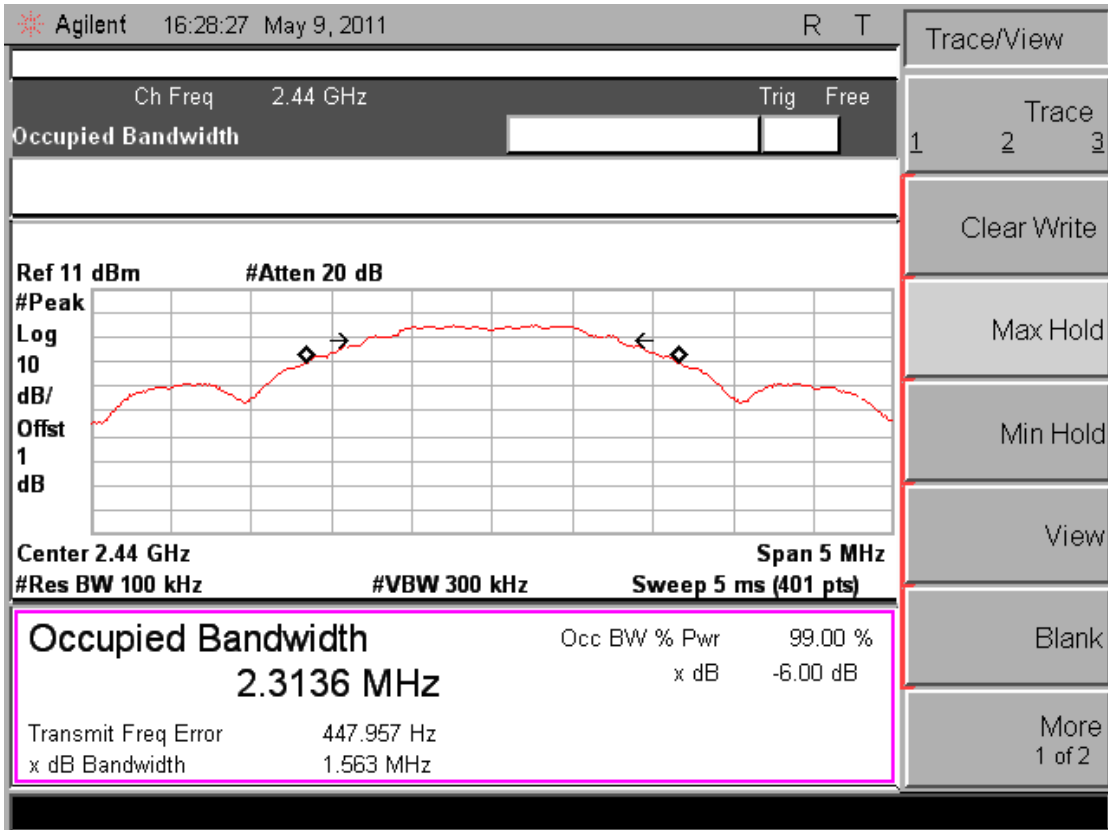

High Channel

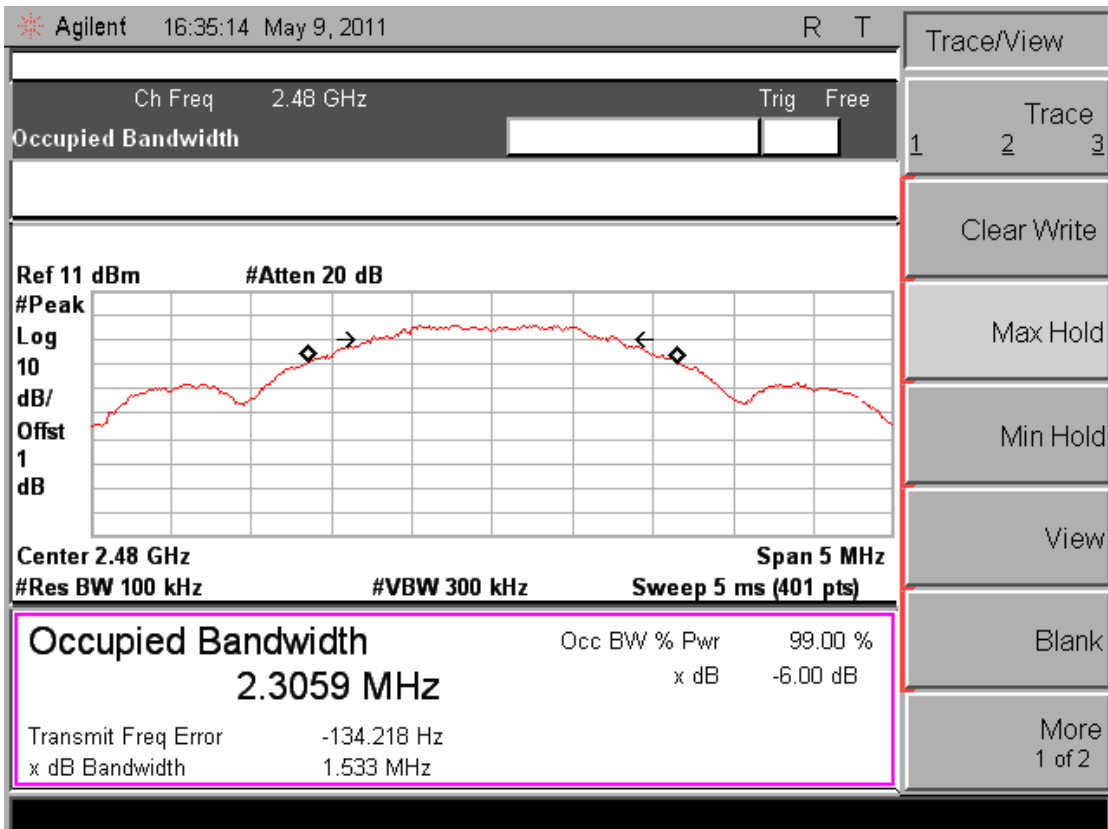

4.8. Antenna Requirement

Standard Applicable

For intentional device, according to FCC 47 CFR Section 15.203, an intentional radiator shall be designed to ensure that no antenna other than that furnished by the responsible party shall be used with the device.

And according to FCC 47 CFR Section 15.247 (c), if transmitting antennas of directional gain greater than 6dBi are used, the power shall be reduced by the amount in dB that the directional gain of the antenna exceeds 6dBi.

Refer to statement below for compliance.

The manufacturer may design the unit so that the user can replace a broken antenna, but the use of a standard antenna jack or electrical connector is prohibited. Further, this requirement does not apply to intentional radiators that must be professionally installed.

Antenna Connected Construction

The antenna used in this product is a PIFA Antenna .The maximum Gain of the antenna only 3.0dBi. Detial please see the photos as following:

