



TEST REPORT

FCC ID: X3U-TK110

Applicant: Topten electronics Technology Limited
Address : Room2007,Tower B,Gaoke Building, 908 Tianhe North Road,
Guangzhou,China

Equipment Under Test(EUT):

Name : GPS Vehicle Tracker
Model : TK110

In Accordance with: FCC PART 2; FCC PART 22H; FCC PART 24E

Report No : STE100104007
Date of Test : Jan 05---06, 2010
Date of Issue : Jan 07, 2010

Test Result: **PASS**

In the configuration tested, the EUT complied with the standards specified above

Authorized Signature

A handwritten signature in black ink, appearing to read 'Mark Zhu', is written over a horizontal line.

(Mark Zhu)

General Manager

The manufacture should ensure that all the products in series production are in conformity with the product sample detailed in this report. If the product in this report is used in any configuration other than that detailed in the report, the manufacturer must ensure the new system complies with all relevant standards. Any mention of Shenzhen Certification Technology Service Co., Ltd. Or test done by Shenzhen Certification Technology Service Co., Ltd. Approvals in connection with, distribution or use of the product described in this report must be approved by Shenzhen Certification Technology Service Co., Ltd. Approvals in writing.

Contents

1. General Information	4
1.1. Description of Device (EUT)	4
1.2. Test Lab information	4
2. Summary of test	5
2.1. Summary of test result	5
2.2. Assistant equipment used for test	5
2.3. Test mode	6
2.4. Test Environment Conditions	6
2.5. Measurement Uncertainty (95% confidence levels, k=2)	6
2.6. Test Equipment	7
3. Conducted Output power	8
3.1. Block Diagram of Test Setup	8
3.2. Limit	8
3.3. Test Procedure	8
3.4. Test Result	8
4. Radiated Output power	9
4.1. Block Diagram of Test Setup	9
4.2. Limit	9
4.3. Test Procedure	9
4.4. Test Result	10
5. Occupied Bandwidth	11
5.1. Block Diagram of Test Setup	11
5.2. Limit	11
5.3. Test Procedure	11
5.4. Test Result	12
5.5. Original test data	12
6. Frequency stability	16
6.1. Block Diagram of Test Setup	16
6.2. Limit	16
6.3. Test Procedure	16
6.4. Test Result	17
7. Conducted spurious emissions	19
7.1. Block Diagram of Test Setup	19
7.2. Limit	19
7.3. Test Procedure	19
7.4. Test Result	19
8. Radiated Spurious emissions	26
8.1. Block Diagram of Test Setup	26
8.2. Limit	26
8.3. Test Procedure	26
8.4. Test Result	27
9. Block Edge Compliance	29
9.1. Block Diagram of Test Setup	29

9.2. Limit.....	29
9.3. Test Procedure.....	29
9.4. Test Result.....	30
10. Testsetup photo	32
11. Photos of EUT	34

1. General Information

1.1. Description of Device (EUT)

EUT	:	GPS Vehicle Tracker
Model No.	:	TK110
Power supply	:	DC12V
Radio Technology	:	GSM/GPRS 850/900/1800/1900
GPRS Multislot Class	:	Class 10
Power class	:	GSM/GPRS 850/900: Class 4 GSM/GPRS 1800/1900: Class 1
Operation frequency	:	824.2MHz—848.8MHz and 1850.2MHz—1909.8MHz
FCC Operation frequency	:	824.2MHz—848.8MHz and 1850.2MHz—1909.8MHz
Modulation	:	GMSK
Antenna Type	:	External antenna, Gain:3.5dBi
Applicant	:	Topten electronics Technology Limited
Address	:	Room2007,Tower B, Gaoke Building, 908 Tianhe North Road, Guangzhou, China

1.2. Test Lab information

Shenzhen Certification Technology Service Co., Ltd.
3F, Bldg.27, Area A, Tanglang Industrial Zone, Xili Town, Nanshan District,
Shenzhen 518055, Guangdong, P.R. China
FCC Registered No.:305283

2. Summary of test

2.1. Summary of test result

Description of Test Item	Standard	Results
Conducted Output power	FCC PART 2: 2.1046 FCC PART 22H: 22.913 (a) FCC PART 24E: 24.232 (c)	PASS
Radiated Output power(erp/eirp)	FCC PART 22H:22.913 (a) FCC PART 24E:24.232(c)	PASS
Occupied bandwidth	FCC PART 2: 2.1049 FCC PART 22H: 22.917 (b) FCC PART 24E: 24.238 (b)	PASS
Frequency stability	FCC PART 2: 2.1055 FCC PART 22H: 22.355 FCC PART 24E: 24.235	PASS
Conducted spurious emission (Antenna terminal)	FCC PART 2: 2.1051 FCC PART 22H: 22.917 FCC PART 24E: 24.238	PASS
Radiated spurious emissions	FCC PART 2: 2.1053 FCC PART 22H: 22.917 FCC PART 24E: 24.238	PASS
Block edge compliance	FCC PART 22H: 22.917 (b) FCC PART 24E: 24.238 (b)	PASS
Power Line Conducted Emission Test	FCC Part 15: 15.207 ANSI C63.4: 2003	N/A

2.2. Assistant equipment used for test

N/A

2.3. Test mode

During all testing, EUT is in link mode with base station emulator at maximum power level in each test mode and channel as below:

Mode	Channel	Frequency(MHz)
GSM 850	128	824.2
	190	836.6
	251	848.8
PCS 1900	512	1850.2
	661	1880.0
	810	1909.8

2.4. Test Environment Conditions

Temperature range	21-25°C
Humidity range	40-75%
Pressure range	86-106kPa

2.5. Measurement Uncertainty (95% confidence levels, k=2)

Item	MU	Remark
Uncertainty for Power point Conducted Emissions Test	2.42dB	
Uncertainty for Radiation Emission test in 3m chamber (30MHz to 1GHz)	3.54dB	Polarize: V
	4.1dB	Polarize: H
Uncertainty for Radiation Emission test in 3m chamber (1GHz to 25GHz)	2.08dB	Polarize: H
	2.56dB	Polarize: V
Uncertainty for radio frequency	1×10 ⁻⁹	
Uncertainty for conducted RF Power	0.65dB	
Uncertainty for temperature	0.2°C	
Uncertainty for humidity	1%	
Uncertainty for DC and low frequency voltages	0.06%	

2.6. Test Equipment

Equipment	Manufacture	Model No.	Serial No.	Last cal.	Cal Interval
3m Semi-Anechoic	ETS-LINDGREN	N/A	SEL0017	16/06/2009	1 Year
Spectrum analyzer	Agilent	E4443A	MY46185649	06/06/2009	1 Year
Receiver	R&S	ESCI	100492	04/06/2009	1 Year
Receiver	R&S	ESCI	101202	07/01/2009	1 Year
Bilog Antenna	Sunol	JB3	A121206	04/06/2009	1 Year
Horn Antenna	EMCO	3115	640201028-06	04/06/2009	1 Year
Power Meter	Anritsu	ML2487A	6K00001491	02/23/2009	1 Year
ETS Horn Antenna	ETS	3160	SEL0076	12/08/2009	1 Year
Active Loop Antenna	Beijing Daze	ZN30900A	SEL0097	15/06/2009	1 Year
Cable	Resenberger	N/A	No.1	04/06/2009	1 Year
Cable	SCHWARZBEC K	N/A	No.2	04/06/2009	1 Year
Cable	SCHWARZBEC K	N/A	No.3	04/06/2009	1 Year
Pre-amplifier	R&S	AFS42-00101 800-25-S-42	SEL0081	18/06/2009	1 Year
Pre-amplifier	R&S	AFS33-18002 650-30-8P-44	SEL0080	18/06/2009	1 Year
Base station	Agilent	E5515C	GB44300243	May.08, 09	1 Year
Temperature controller	Terchy	MHQ	120	May.08, 09	1 Year
Power divider	Anritsu	K240C	020346	May.08, 09	1 Year
Signal Generator	HP	83732B	VS3449051	May.08, 09	1 Year
Attenuator	Agilent	8491B	MY39262165	May.08, 09	1 Year
GPS Signal	Welnavigate	GS50	6423517	N/A	N/A

3. Conducted Output power

3.1. Block Diagram of Test Setup



3.2. Limit

Cellular Telephone 850MHz	PCS 1900MHz
38.5dBm(ERP)	33dBm(EIRP)

3.3. Test Procedure

- (1) The EUT’s RF output port was connected to base station.
- (2) Set EUT at maximum power level through base station by power level command
- (3) Measure the maximum output power of EUT at each frequency band and mode by base station.

3.4. Test Result

EUT: GPS Vehicle Tracker		M/N:TK110		Power: DC 12V		
Ambient Temperature:24℃		Relative Humidity: 62%				
Test date: 2010-01-05		Test site: RF site		Tested by: TaTa_Chen		
Conclusion: PASS						
Mode	Channel	PK Output Power(dBm)	ERP (dBm)	EIRP (dBm)	Limit	
					ERP(dBm)	EIRP(dBm)
GSM 850	128	31.70	33.05	/	38.5	/
	190	31.69	33.04	/	38.5	/
	251	31.65	33.00	/	38.5	/
PCS 1900	512	29.10	/	32.60	/	33
	661	29.03	/	32.53	/	33
	810	29.13	/	32.63	/	33
Note: EIRP=Pk output power +Antenna Gain(3.5dBi); ERP=PK output power + Antenna Gain(3.5dBi) -2.15						

4. Radiated Output power

4.1. Block Diagram of Test Setup

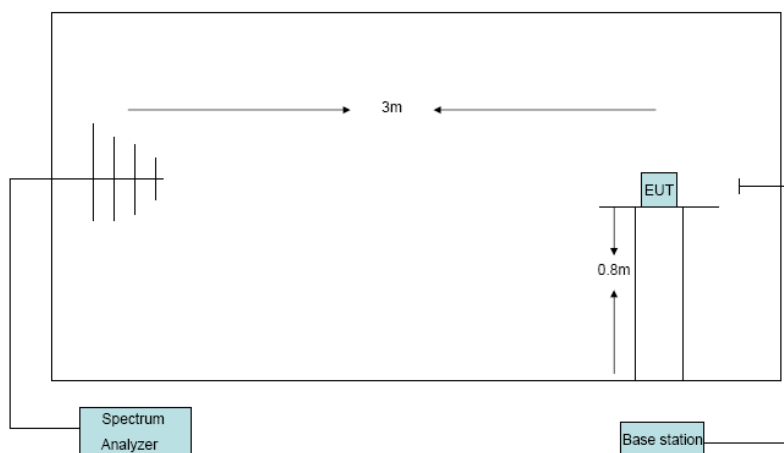

4.2. Limit

Cellular Telephone 850MHz	PCS 1900MHz
38.5dBm(ERP)	33dBm(EIRP)

4.3. Test Procedure

1. The EUT was placed on a non-conductive rotating platform with 0.8 meter height in an anechoic chamber. The radiated emission at the fundamental frequency was measured at 3 m with a test antenna and a spectrum analyzer with RBW= 3MHz, VBW= 3MHz and peak detector settings.
2. During the measurement, the EUT was enforced in maximum power and linked with a base station. The highest emission was recorded from analyzer power level (LVL) from the 360 degrees rotation of the turntable and the test antenna raised and lowered over a range from 1 to 4 meters in both horizontally and vertically polarized orientations.
3. Effective Isotropic Radiated Power (EIRP) was measured by substitution method according to TIA/EIA-603-C. The EUT was replaced by dipole antenna (for frequency below 1GHz) or Horn antenna (for frequency above 1GHz) at same location with same polarization of receiver antenna and then a known power of each measure frequency from S.G. was applied into the dipole antenna or Horn antenna through a Tx cable, and then recorded the maximum Analyzer reading through raised and lowered the test antenna. The correction factor (in dB) = S.G. - Tx Cable loss + Substitution antenna gain - Substitution antenna Loss (only for Dipole antenna) - Analyzer reading. Then the EUT's

EIRP was calculated with the correction factor, $EIRP = LVL + \text{Correction factor}$ and $ERP = EIRP - 2.15$

4.4. Test Result

EUT: GPS Vehicle Tracker M/N:TK110					
Power:DC 12V					
Ambient Temperature:23°C			Relative Humidity: 60%		
Test date: 2010-01-05			Test site: RF site	Tested by: TaTa_Chen	
Conclusion: PASS					
Mode	Channel	LVL (dBm)	Correction factor(dB)	ERP (dBm)	EIRP (dBm)
GSM 850	128	0.91	30.42	29.18	/
	190	1.72	30.21	29.78	/
	251	1.13	30.05	29.03	/
PCS 1900	512	-20.26	46.80	/	26.54
	661	-20.34	46.45	/	26.11
	810	-20.35	46.58	/	26.23
ERP=LVL+Correction factor -2.15					
EIRP=LVL+Correction factor					

5. Occupied Bandwidth

5.1. Block Diagram of Test Setup

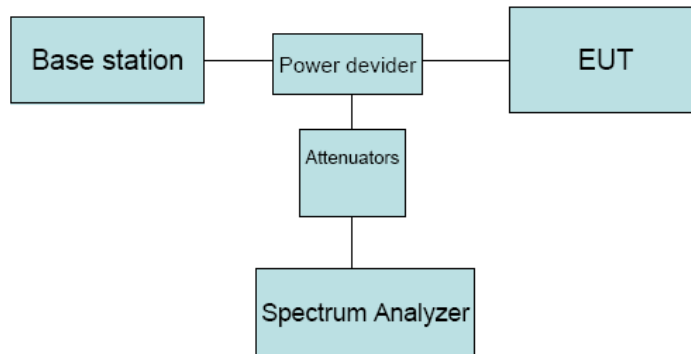

5.2. Limit

N/A

5.3. Test Procedure

1. The EUT' RF output port was connected to Spectrum Analyzer and Base Station via power divider.
2. Spectrum analyzer's occupied bandwidth measure function was used to measure 99% bandwidth and -26dBc bandwidth

5.4. Test Result

EUT: GPS Vehicle Tracker M/N:TK110			
Power:DC 12V			
Ambient Temperature:23°C		Relative Humidity: 60%	
Test date: 2010-01-05		Test site: RF site	Tested by: TaTa_Chen
Mode	Channel	99% bandwidth (KHz)	-26dBc bandwidth (KHz)
GSM 850	128	244.84	305.639
	190	246.31	317.54
	251	245.03	311.36
PCS 1900	512	246.65	309.01
	661	246.00	315.44
	810	247.68	311.02

5.5. Original test data

GSM 850 CH128

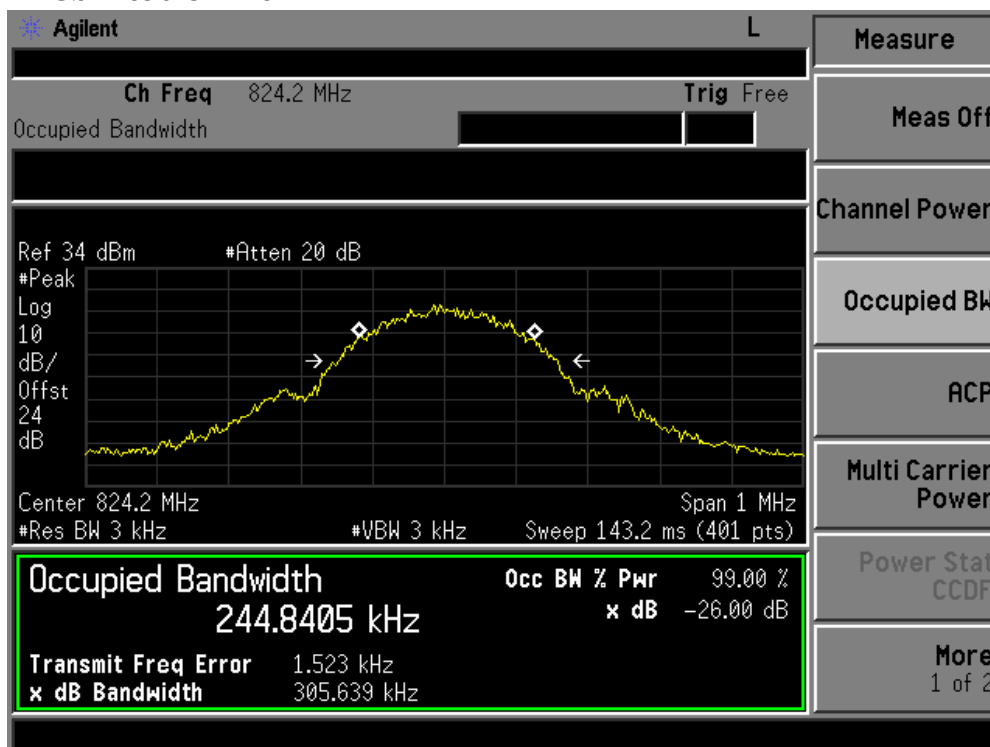

GSM 850 CH190

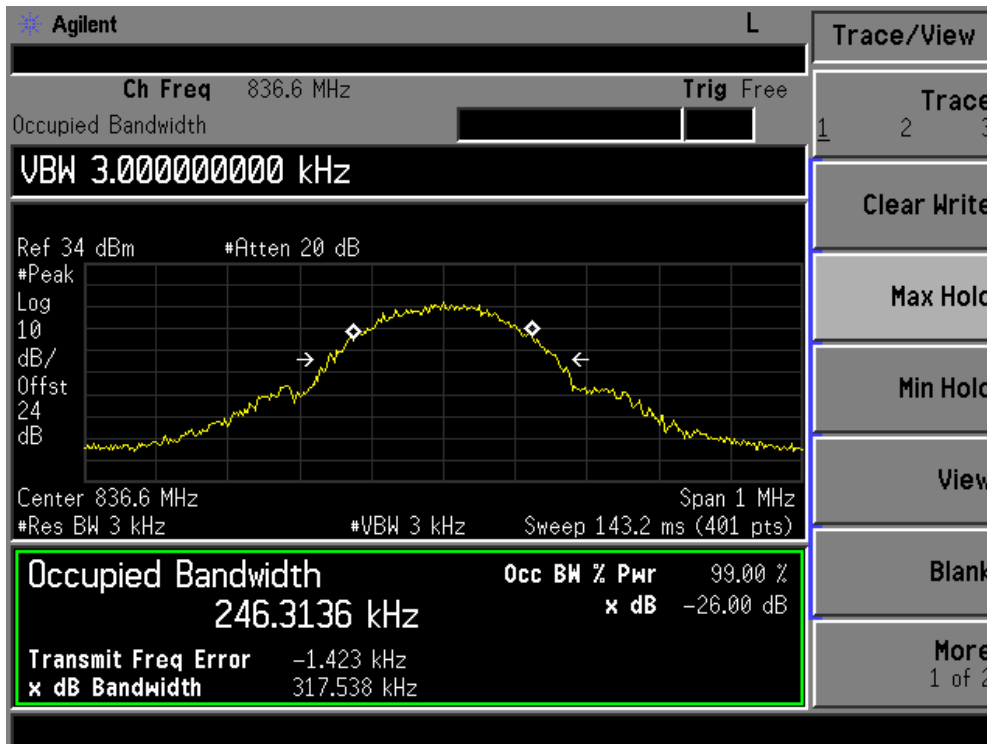

GSM 850 CH251

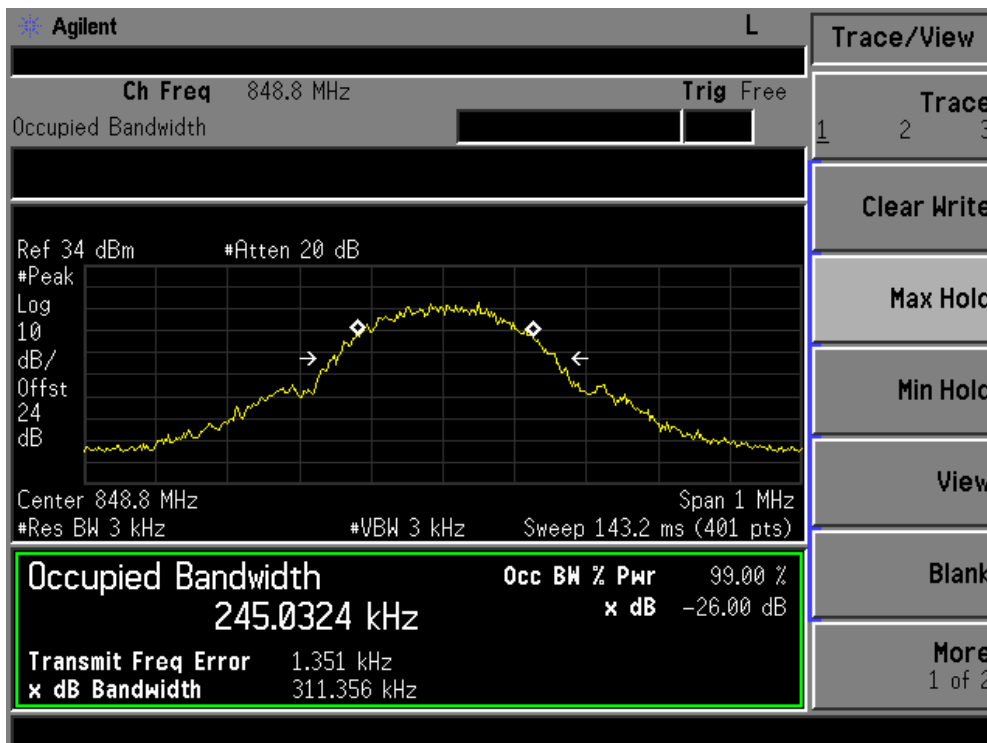

PCS 1900 CH512

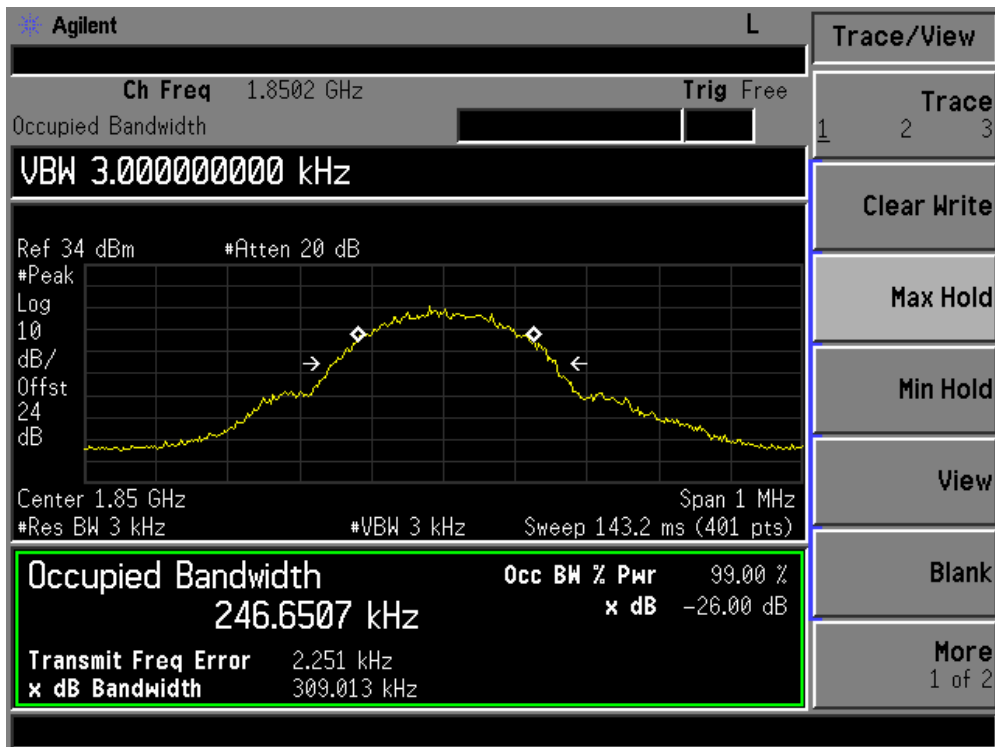

PCS 1900 CH661

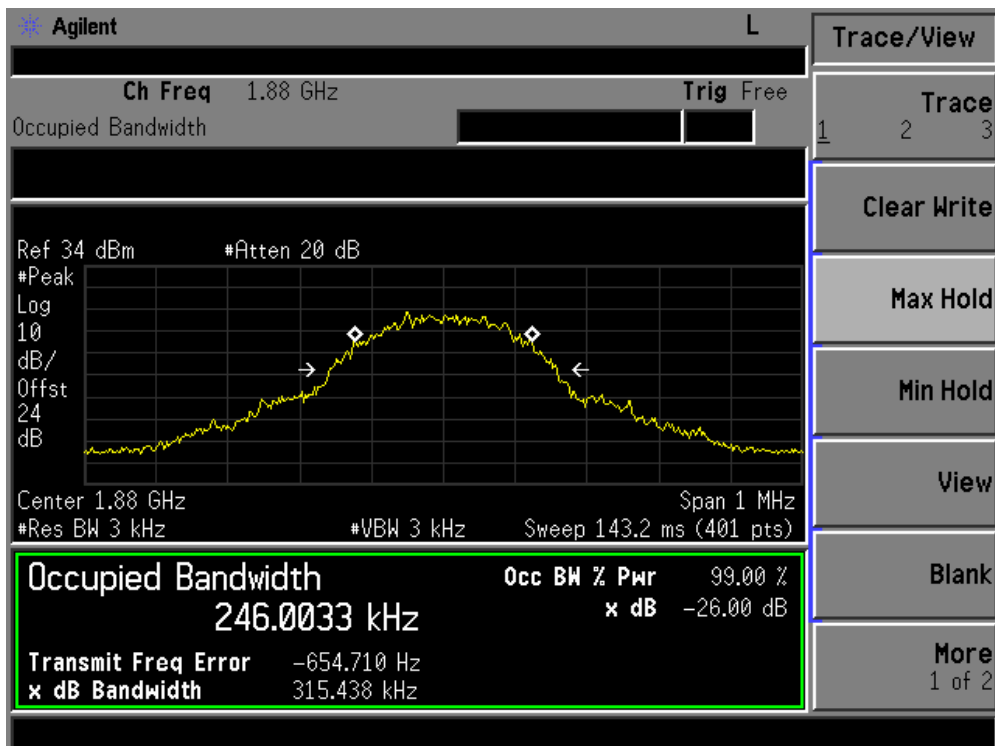

PCS 1900 CH810

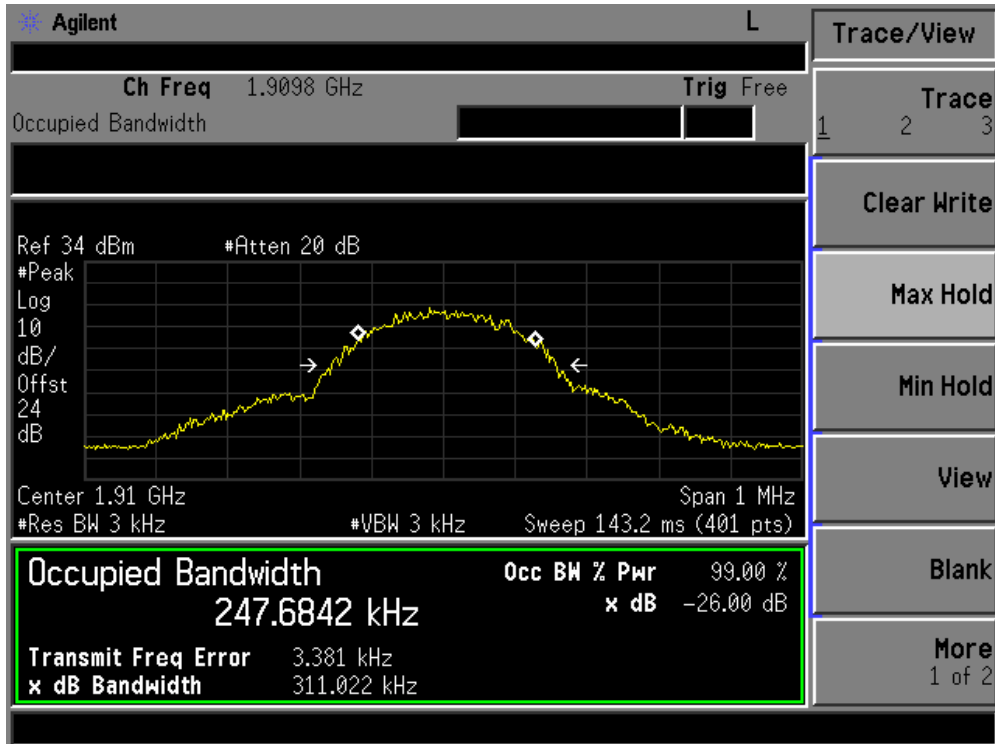

6. Frequency stability

6.1. Block Diagram of Test Setup

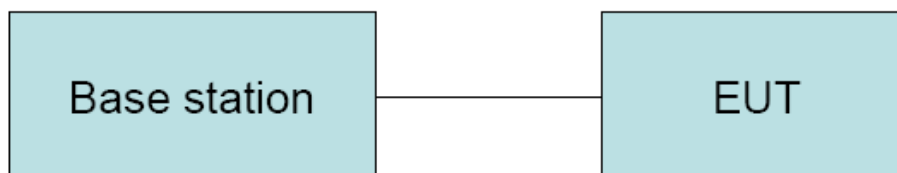

6.2. Limit

Cellular Telephone 850MHz	PCS 1900MHz
± 2.5 ppm	Must stay within the authorized frequency block

6.3. Test Procedure

Test Procedures for Temperature Variation:

1. The EUT was set up in the thermal chamber and connected with the base station.
2. With power OFF, the temperature was decreased to -30°C and the EUT was stabilized for three hours. Power was applied and the maximum change in frequency was recorded within one minute.
3. With power OFF, the temperature was raised in 10°C step up to 50°C . The EUT was stabilized at each step for at least half an hour. Power was applied and the maximum frequency change was recorded within one minute.
4. If the EUT can not be turned on at -30°C , the testing lowest temperature will be raised in 10°C step until the EUT can be turned on.

Test Procedures for Voltage Variation

1. The EUT was placed in a temperature chamber at $25\pm 5^{\circ}\text{C}$ and connected with the base station.
2. The power supply voltage to the EUT was varied from 15V to 9V(Note)
3. The variation in frequency was measured for the worst case.

6.4. Test Result

EUT: GPS Vehicle Tracker M/N:TK110			
Power:DC 12V			
Ambient Temperature:23℃		Relative Humidity: 60%	
Test date: 2010-01-05		Test site: RF site	Tested by: TaTa_Chen
Conclusion:PASS			
Mode	Voltage (V)	Frequency error (Hz)	frequency error (ppm)
GSM 850 CH 190	15V	-27	-0.032
	14V	-27	-0.032
	13V	29	0.035
	12V	-25	-0.030
	11V	31	0.037
	10V	-33	-0.039
	9V	31	0.037
PCS 1900 CH661	15V	-33	-0.018
	14V	-31	-0.016
	13V	37	0.020
	12V	-36	-0.019
	11V	39	0.021
	10V	-39	-0.021
	9V	-32	-0.017

Mode	Temperature (°C)	Frequency error (Hz)	frequency error (ppm)
GSM 850 CH190	-30	27	0.032
	-20	-25	-0.030
	-10	-22	-0.026
	0	30	0.036
	10	-29	-0.035
	20	-19	-0.023
	30	22	0.026
	40	-27	-0.032
	50	24	0.029
PCS 1900 CH661	-30	-24	-0.013
	-20	-27	-0.014
	-10	38	0.020
	0	-19	-0.010
	10	-29	-0.015
	20	25	0.013
	30	-24	-0.013
	40	-23	-0.012
	50	23	0.012

7. Conducted spurious emissions

7.1. Block Diagram of Test Setup

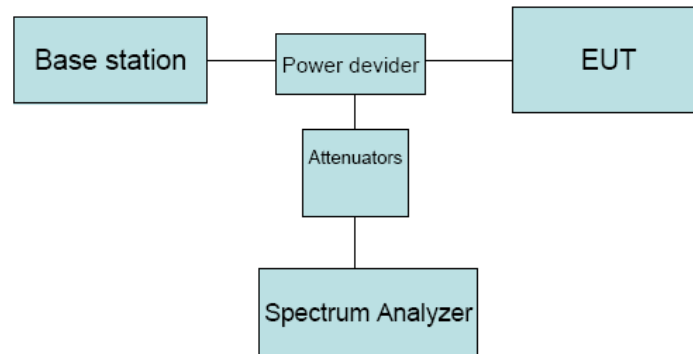

7.2. Limit

The mean power of emissions must be attenuated below the mean power of the unmodulated carrier (P) on any frequency outside the frequency band by at least $(43 + 10 \log P)$ dB, in this case, -13dBm.

7.3. Test Procedure

1. The EUT was connected to spectrum analyzer and base station via power divider.
2. The low, middle and high channels of each band and mode's spurious emissions for 30MHz to 10th Harmonic were measured by Spectrum analyzer.

7.4. Test Result

PASS

Test Mode: GSM 850 CH 128

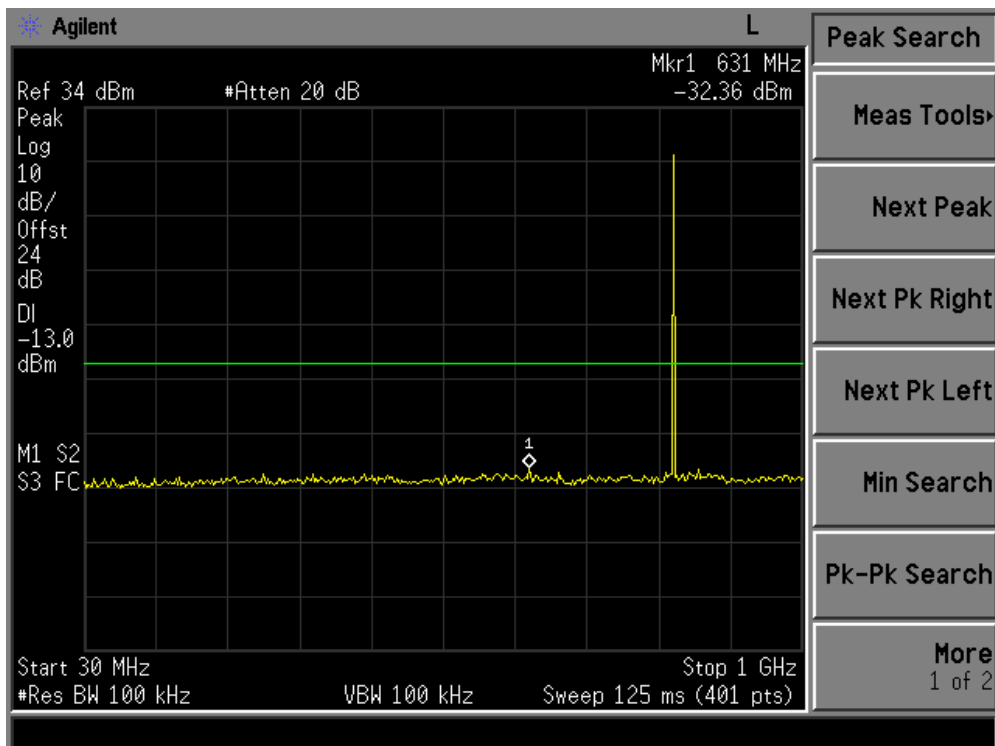
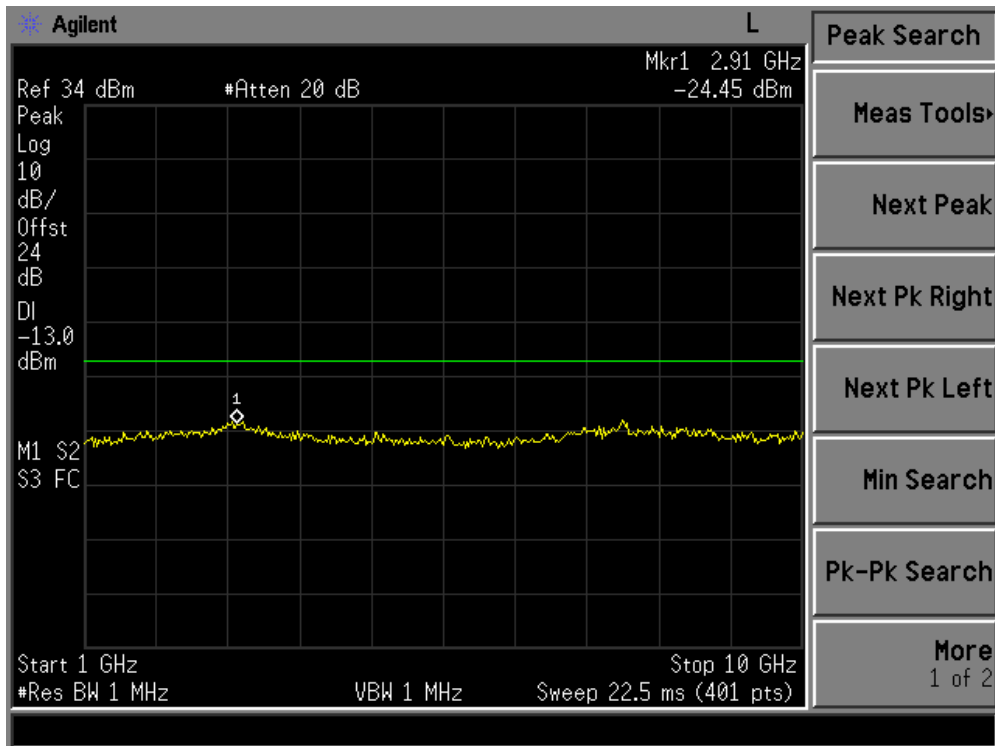

Test Mode: GSM 850 CH 190

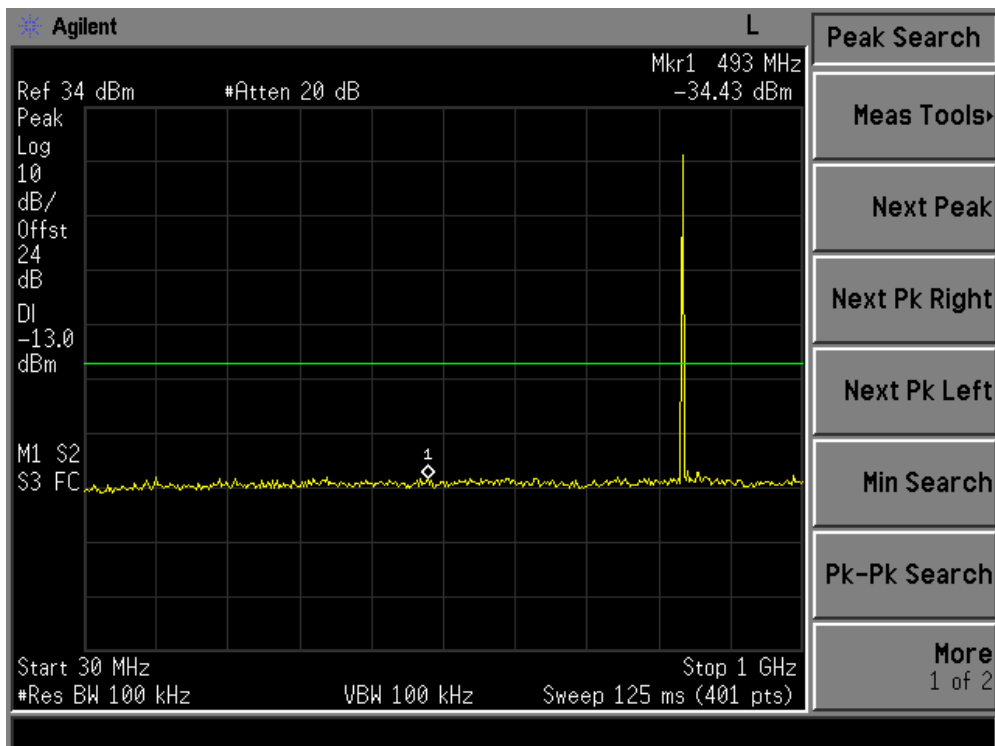
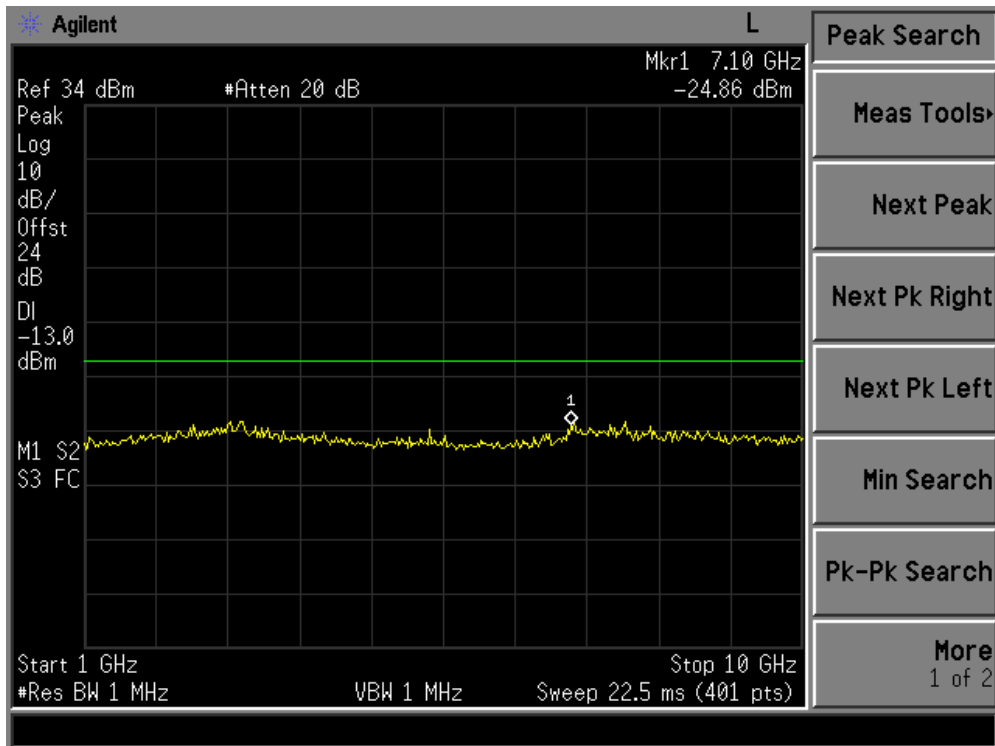

Test Mode: GSM 850 CH 251

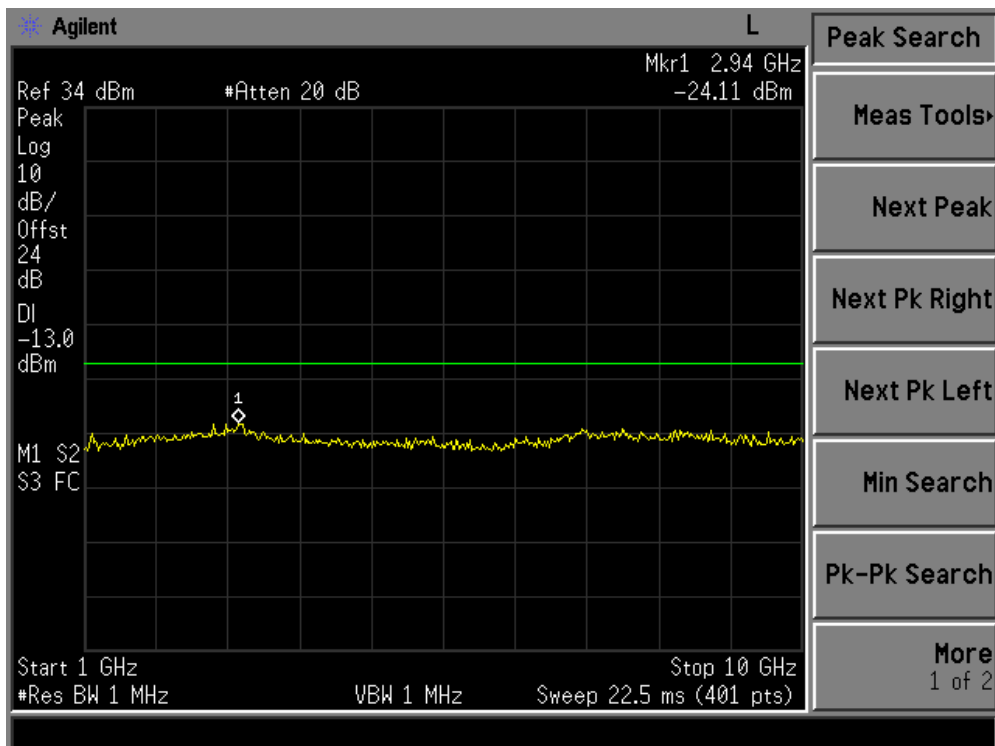
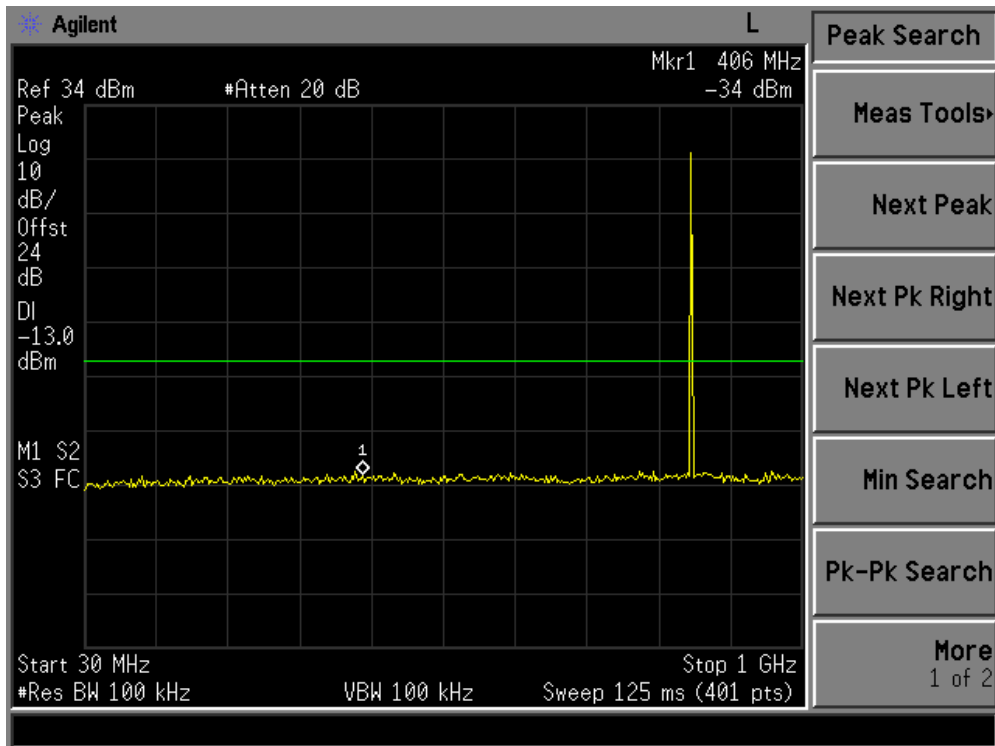

Test Mode: GSM 1900 CH 512

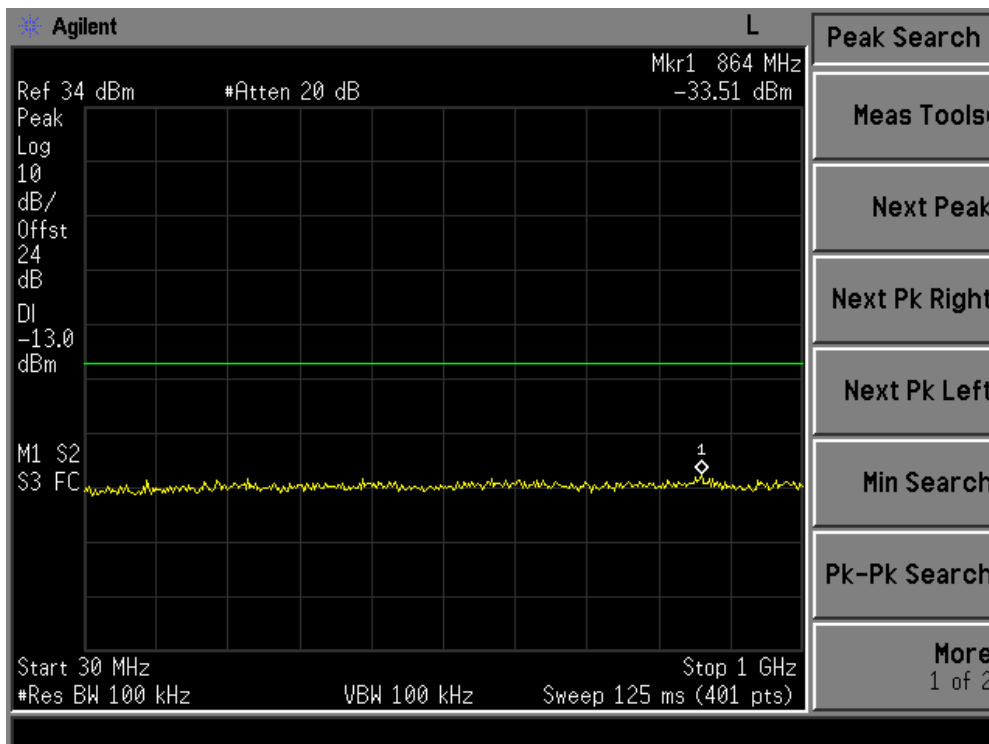
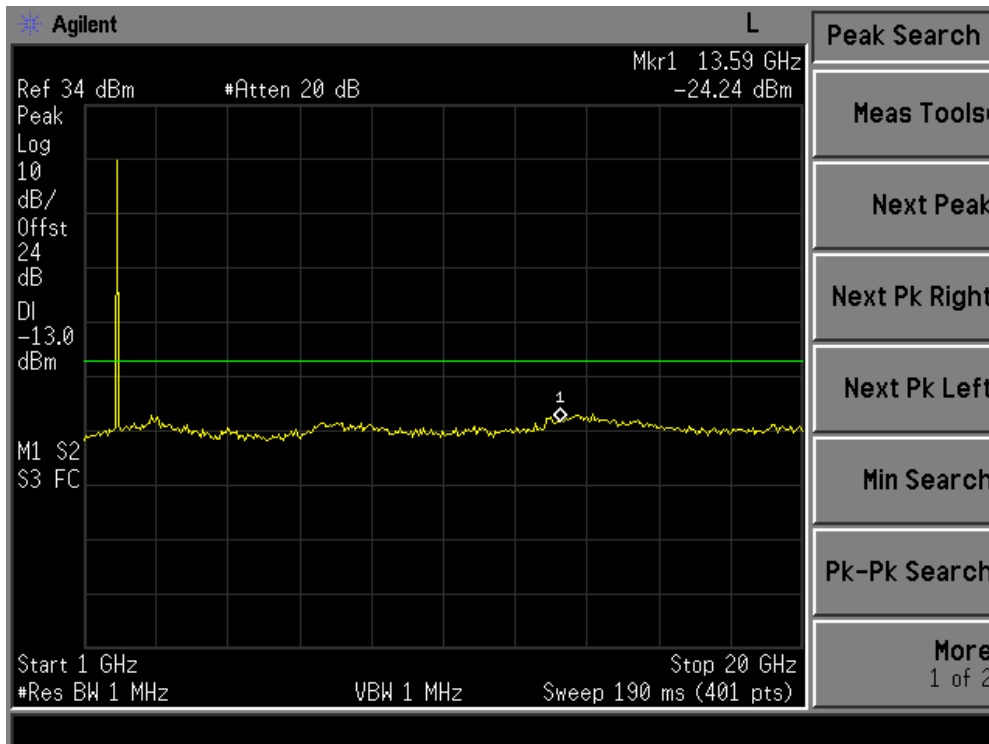

Test Mode: GSM 1900 CH 661

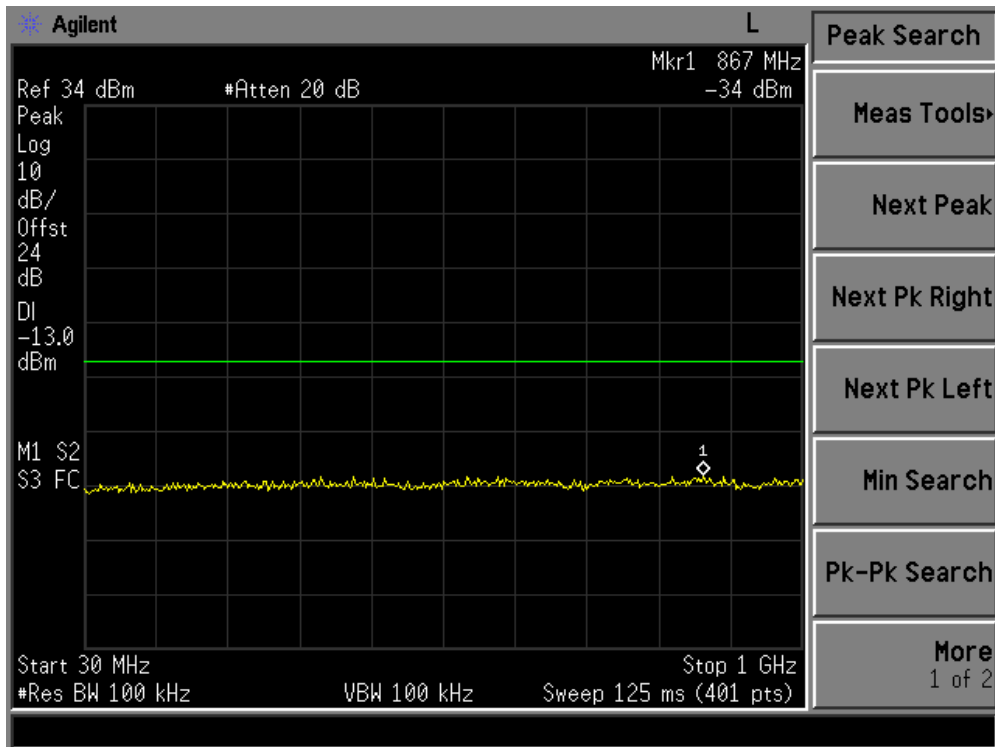
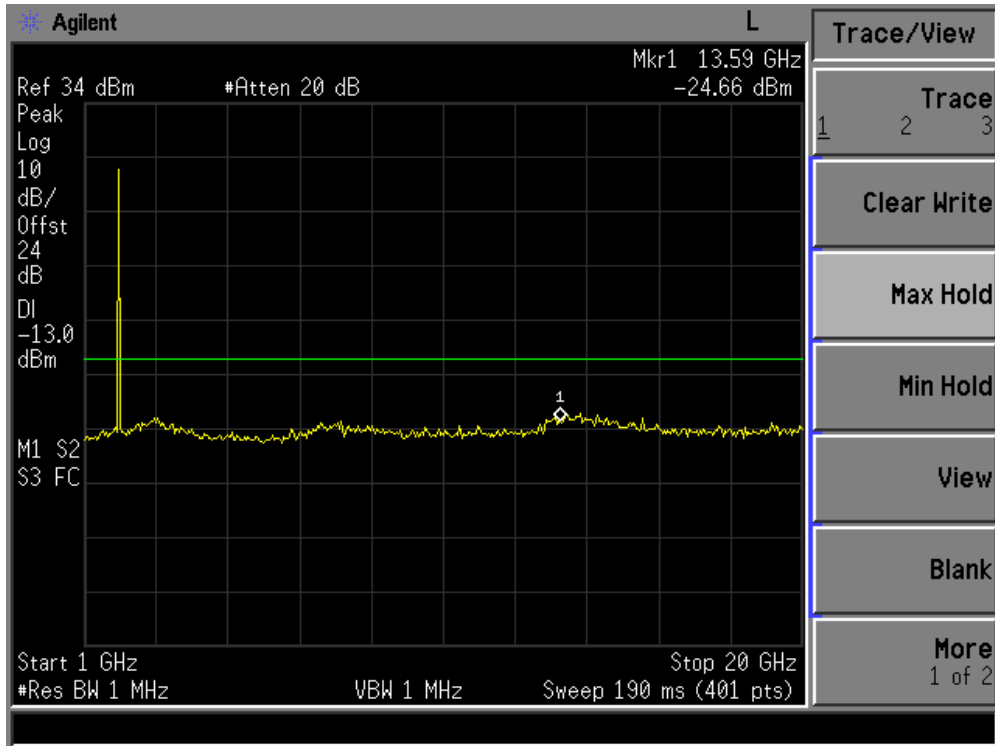

Test Mode: GSM 1900 CH 810

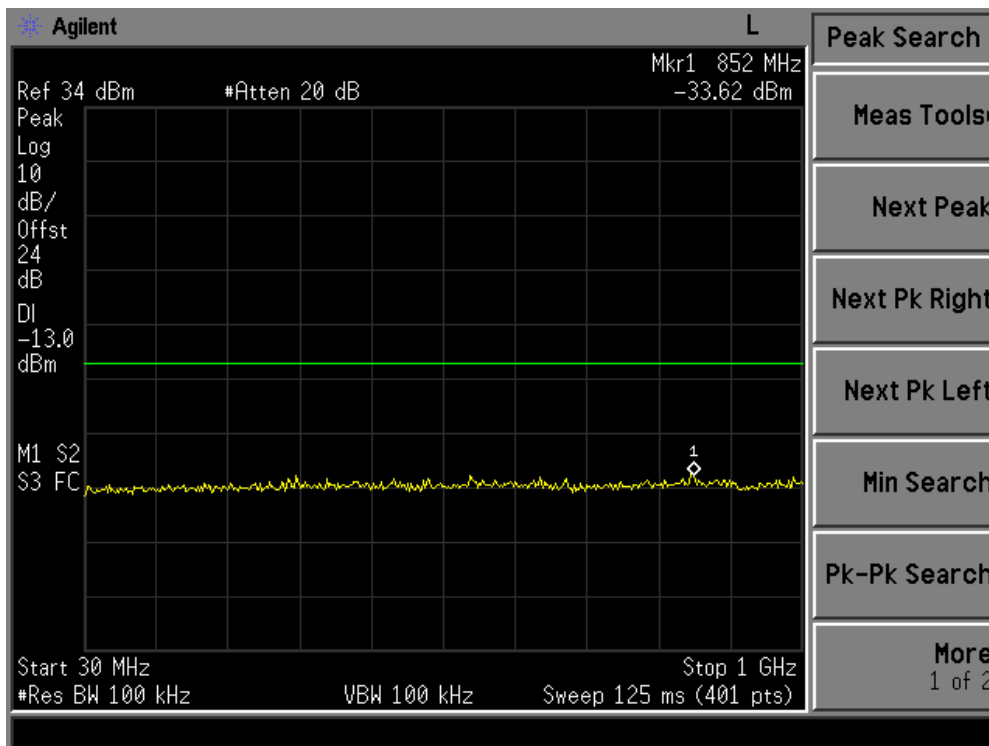
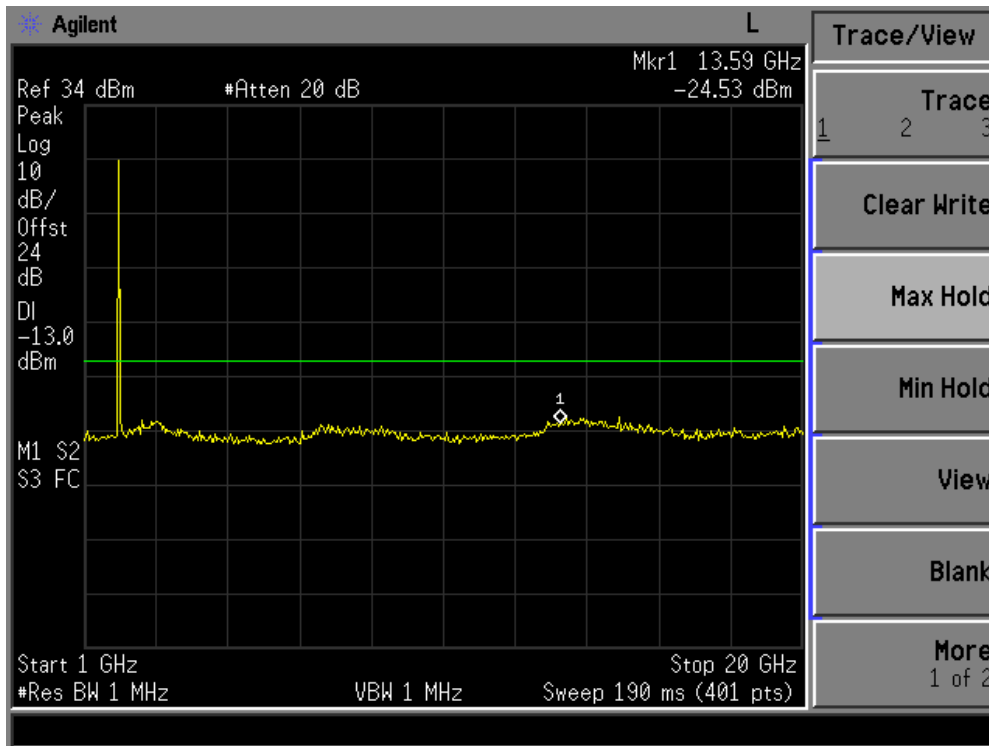

8. Radiated Spurious emissions

8.1. Block Diagram of Test Setup

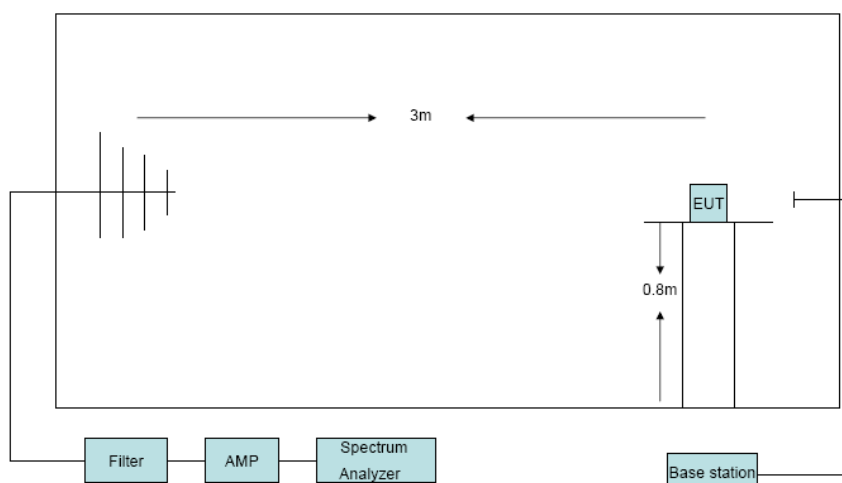

8.2. Limit

The mean power of emissions must be attenuated below the mean power of the unmodulated carrier (P) on any frequency outside the frequency band by at least $(43 + 10 \log P)$ dB, in this case, -13dBm.

8.3. Test Procedure

1. The EUT was placed on a non-conductive rotating platform with 0.8 meter height in an anechoic chamber. The radiated spurious emissions from 30MHz to 10th harmonious of fundamental frequency were measured at 3m with a test antenna and a spectrum analyzer with RBW= 1MHz,VBW= 1MHz ,peak detector settings.
2. During the measurement, the EUT was enforced in maximum power and linked with a base station.All the spurious emissions(record as LVL) at 3m were measured by rotation of the turntable and the test antenna raised and lowered over a range from 1 to 4 meters in both horizontally and vertically polarized orientations.
3. Final spurious emissions levels were measured by substitution method according to TIA/EIA-603-C. The EUT was replaced by dipole antenna (for frequency below 1GHz) or Horn antenna(for frequency above 1GHz) at same location with same polarize of receiver antenna and then a known power of each measure frequency from S.G. was applied into the dipole antenna or Horn antenna through a Tx cable, and then recorded the maximum Analyzer reading through raised and lowered the test antenna. The correction factor (in dB) = S.G. - Tx Cable loss + Substitution antenna gain

–Substitution antenna Loss(only for Dipole antenna) - Analyzer reading. Then final

spurious emissions were calculated with the correction factor, $EIRP = LVL + \text{Correction factor}$ and $ERP = EIRP - 2.15$

8.4. Test Result

EUT:GPS Vehicle Tracker M/N:TK110						
Power:DC 12V						
Test Date: 2010-01-05		Test site: RF Chamber		Tested by: TaTa_Chen		
Ambient Temperature: 24°C		Relative Humidity: 60%				
Conclusion:PASS						
Test result						
Test Mode: GSM 850 CH128						
Frequency (MHz)	Antenna polarization	LVL (dBm)	Correction factor(dB)	Result (ERP)(dBm)	Limit (dBm)	Margin (dB)
1648.4	H	-59.34	11.50	-49.99	-13	36.99
1648.4	V	-57.23	10.56	-48.82	-13	35.82
Test Mode: GSM 850 CH190						
1673.2	H	-65.12	10.94	-56.33	-13	43.33
2509.8	H	/	/	/	-13	/
1673.2	V	-61.43	10.90	-52.68	-13	39.68
2509.8	V	/	/	/	-13	/
Test mode: GSM 850 CH251						
1697.6	H	-64.32	11.67	-54.8	-13	41.8
2546.4	H	/	/	/	-13	/
1697.6	V	-59.23	11.13	-50.25	-13	37.25
2546.4	V	/	/	/	-13	/

Test Mode: GSM 1900 CH512						
Frequency (MHz)	Antenna polarization	LVL (dBm)	Correction factor(dB)	Result (EIRP)(dBm)	Limit (dBm)	Margin (dB)
3700.4	H	-55.43	8.57	-46.86	-13	33.86
5550.6	H	/	/	/	-13	/
3700.4	V	-53.12	8.37	-44.75	-13	31.75
5550.6	V	/	/	/	-13	/
Test Mode: GSM 1900 CH661						
3760	H	-55.19	8.75	-46.44	-13	33.44
5640	H	/	/	/	-13	/
3760	V	-54.34	8.55	-45.79	-13	32.79
5640	V	/	/	/	-13	/
Test mode: GSM 1900 CH810						
3819.6	H	-57.23	8.94	-48.29	-13	35.29
5729.4	H	/	/	/	-13	/
3819.6	V	-55.12	8.72	-46.4	-13	33.4
5729.4	V	/	/	/	-13	/
Note: All the other emissions not recorded were too low to read, and deemed to comply with limit.						

9. Block Edge Compliance

9.1. Block Diagram of Test Setup

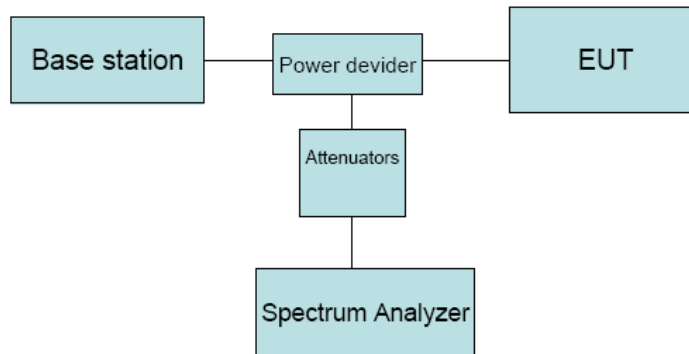

9.2. Limit

The mean power of emissions must be attenuated below the mean power of the unmodulated carrier (P) on any frequency outside the frequency band by at least $(43 + 10 \log P)$ dB, in this case, -13dBm.

9.3. Test Procedure

1. The EUT was connected to Spectrum Analyzer and Base Station via power divider.
2. The band edges of low and high channels for the highest RF powers were measured.

9.4. Test Result

PASS

Test Mode: GSM 850

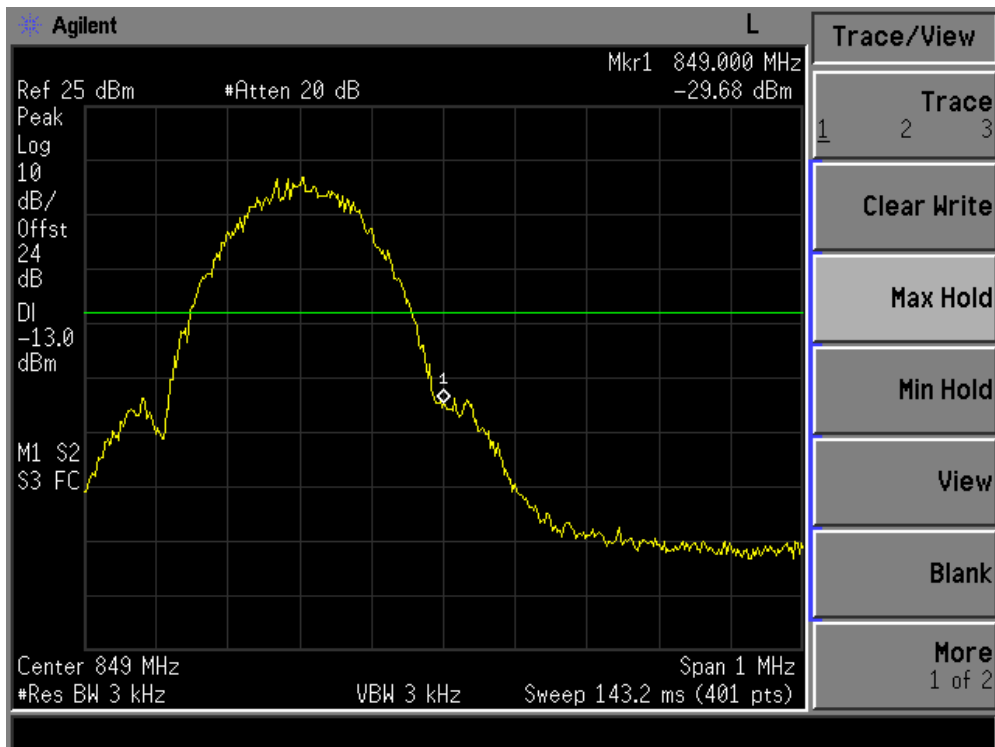
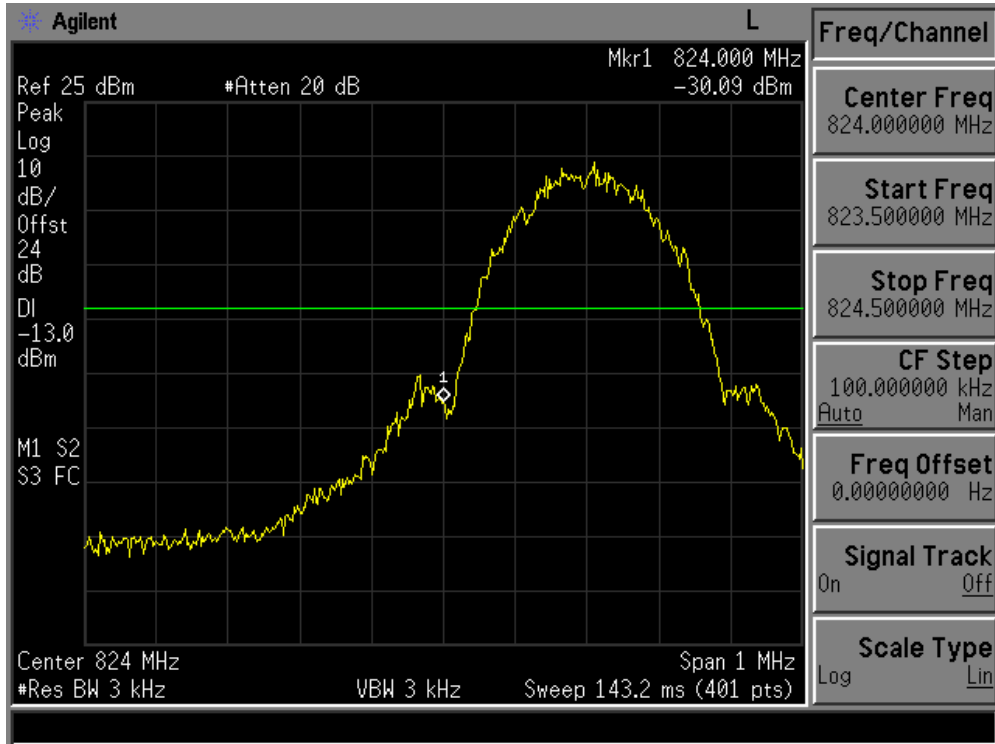

Test Mode: GSM 1900

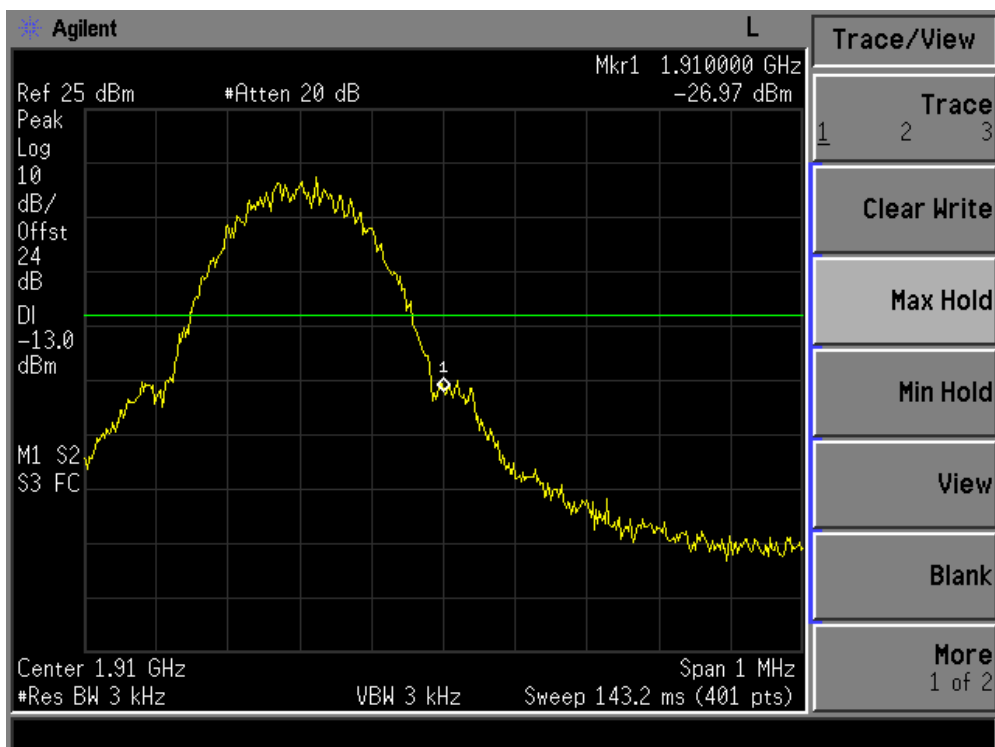
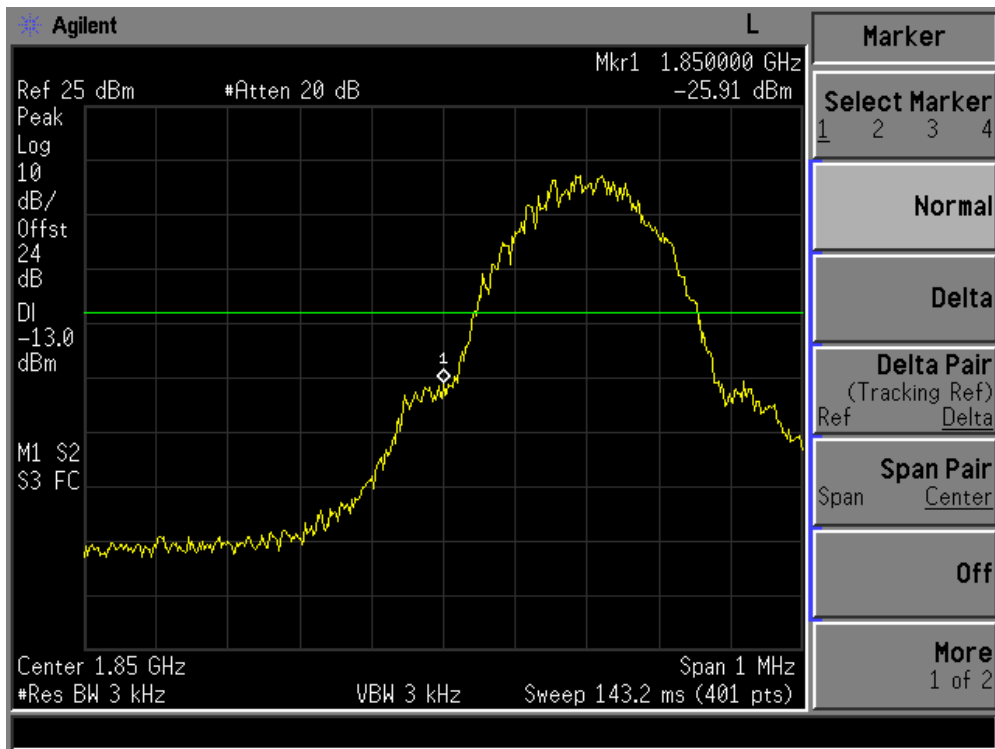

10. Testsetup photo





11.Photos of EUT





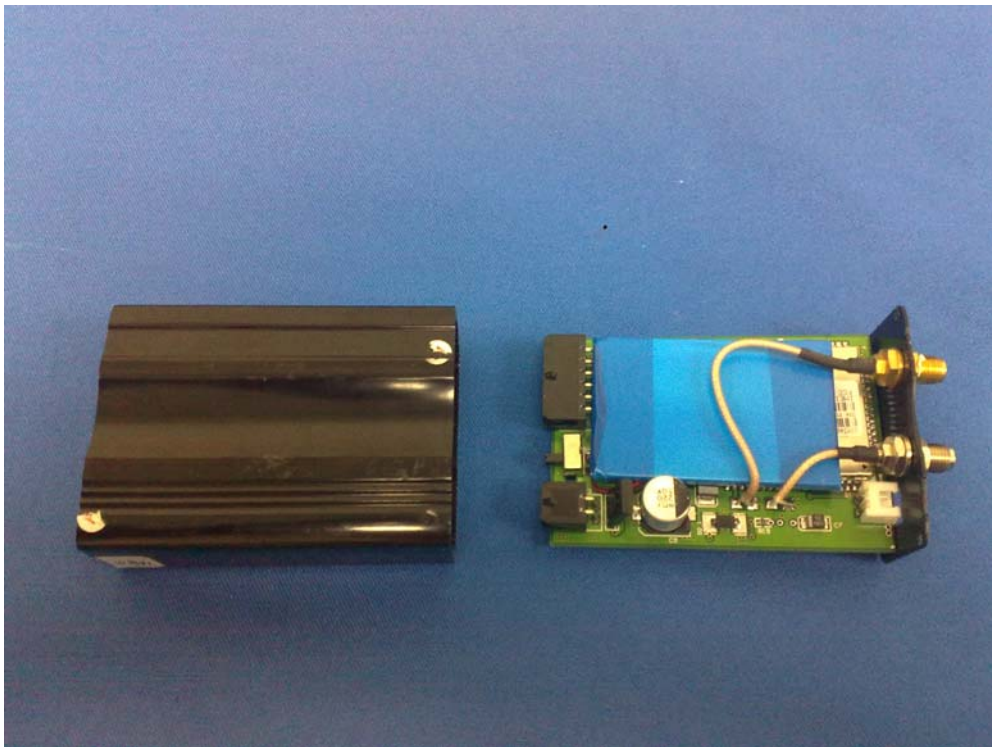

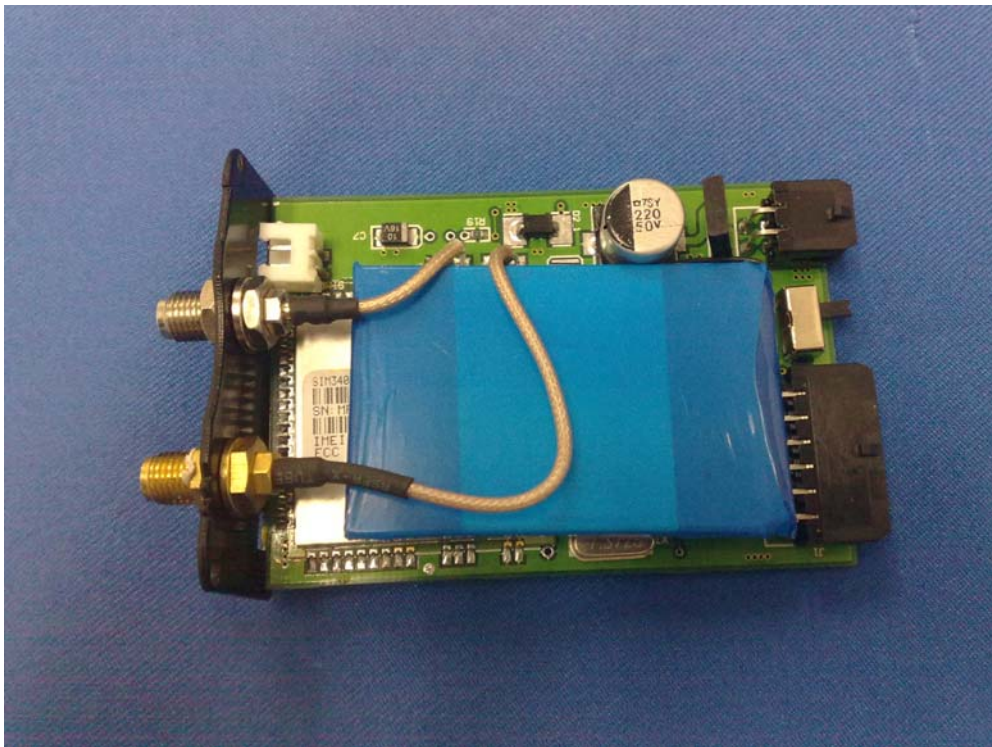

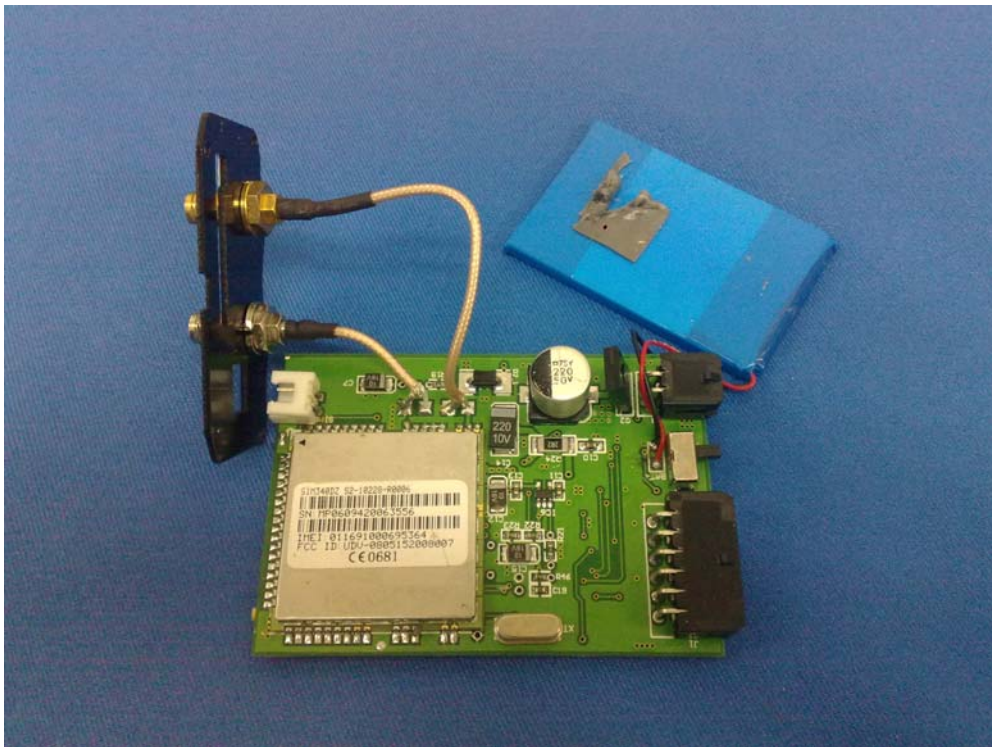

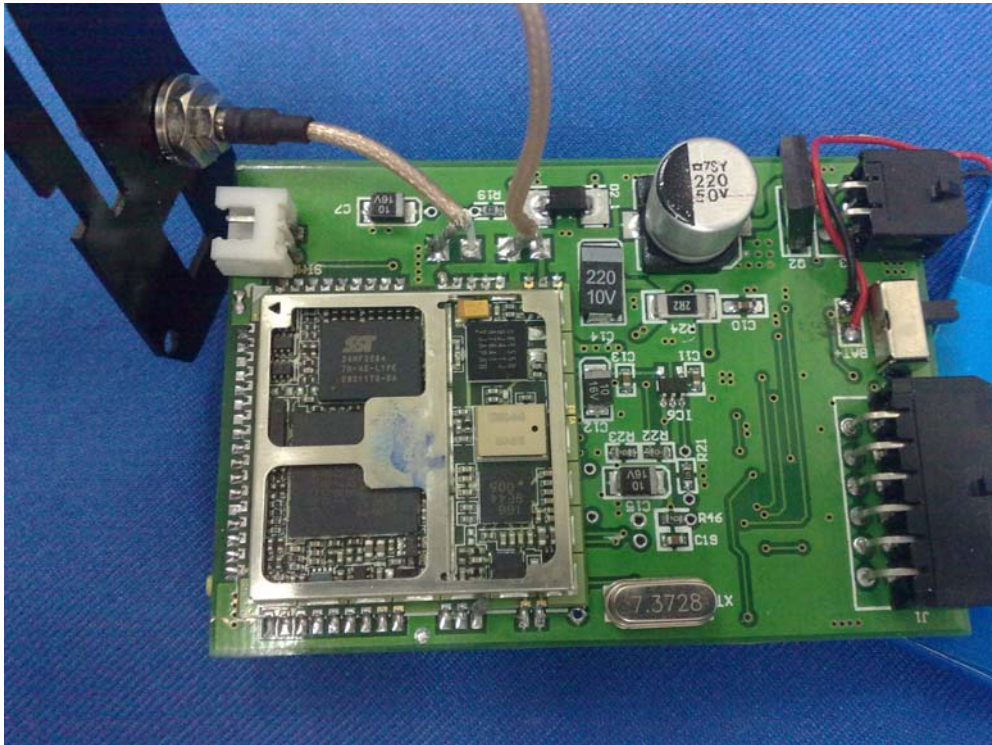

END OF REPOR