



# FCC RF Test Report

APPLICANT : Doro AB  
EQUIPMENT : GSM/WCDMA/LTE Mobile Telephone  
BRAND NAME : doro  
MODEL NAME : Doro Liberto 825  
FCC ID : WS5DORO825E  
STANDARD : FCC Part 15 Subpart C §15.247  
CLASSIFICATION : (DTS) Digital Transmission System

The product was received on Mar. 30, 2015 and testing was completed on Jul. 04, 2015. We, SPORTON INTERNATIONAL (KUNSHAN) INC., would like to declare that the tested sample has been evaluated in accordance with the test procedures and has been in compliance with the applicable technical standards.

The test results in this report apply exclusively to the tested model / sample. Without written approval of SPORTON INTERNATIONAL (KUNSHAN) INC., the test report shall not be reproduced except in full.

Reviewed by: Joseph Lin / Supervisor

Approved by: Jones Tsai / Manager



**SPORTON INTERNATIONAL (KUNSHAN) INC.**  
No. 3-2, PingXiang Road, Kunshan, Jiangsu Province, P. R. China



# TABLE OF CONTENTS

**REVISION HISTORY..... 3**

**SUMMARY OF TEST RESULT ..... 4**

**1 GENERAL DESCRIPTION ..... 5**

    1.1 Applicant ..... 5

    1.2 Manufacturer ..... 5

    1.3 Product Feature of Equipment Under Test ..... 5

    1.4 Product Specification subjective to this standard ..... 5

    1.5 Modification of EUT ..... 6

    1.6 Testing Location ..... 6

    1.7 Applicable Standards ..... 6

**2 TEST CONFIGURATION OF EQUIPMENT UNDER TEST ..... 7**

    2.1 Carrier Frequency Channel ..... 7

    2.2 Pre-Scanned RF Power ..... 8

    2.3 Test Mode ..... 9

    2.4 Connection Diagram of Test System ..... 10

    2.5 Support Unit used in test configuration and system ..... 12

    2.6 EUT Operation Test Setup ..... 12

    2.7 Measurement Results Explanation Example ..... 13

**3 TEST RESULT ..... 14**

    3.1 6dB Bandwidth Measurement ..... 14

    3.2 Output Power Measurement ..... 16

    3.3 Power Spectral Density Measurement ..... 18

    3.4 Conducted Band Edges and Spurious Emission Measurement ..... 20

    3.5 Radiated Band Edges and Spurious Emission Measurement ..... 30

    3.6 AC Conducted Emission Measurement ..... 34

    3.7 Antenna Requirements ..... 39

**4 LIST OF MEASURING EQUIPMENT ..... 40**

**5 UNCERTAINTY OF EVALUATION ..... 41**

**APPENDIX A. CONDUCTED TEST RESULTS**

**APPENDIX B. RADIATED TEST RESULTS**

**APPENDIX C. SETUP PHOTOGRAPHS**

**APPENDIX D. PHOTOGRAPHS OF EUT**





### SUMMARY OF TEST RESULT

Report Section	FCC Rule	Description	Limit	Result	Remark
3.1	15.247(a)(2)	6dB Bandwidth	$\geq 0.5\text{MHz}$	Pass	-
3.2	15.247(b)	Power Output Measurement	$\leq 30\text{dBm}$	Pass	-
3.3	15.247(e)	Power Spectral Density	$\leq 8\text{dBm}/3\text{kHz}$	Pass	-
3.4	15.247(d)	Conducted Band Edges	$\leq 20\text{dBc}$	Pass	-
		Conducted Spurious Emission		Pass	-
3.5	15.247(d)	Radiated Band Edges and Radiated Spurious Emission	15.209(a) & 15.247(d)	Pass	Under limit 3.05 dB at 4824.000 MHz
3.6	15.207	AC Conducted Emission	15.207(a)	Pass	Under limit 6.67 dB at 0.520 MHz
3.7	15.203 & 15.247(b)	Antenna Requirement	N/A	Pass	-



# 1 General Description

## 1.1 Applicant

Doro AB  
Magistratsvägen 10 SE-226 43 Lund Sweden

## 1.2 Manufacturer

BYD PRECISION MFR CO., LTD  
No. 3001, Baohe Road, Baolong Industrial, Longgang, Shenzhen, 518116, P. R. China

## 1.3 Product Feature of Equipment Under Test

Product Feature	
Equipment	GSM/WCDMA/LTE Mobile Telephone
Brand Name	doro
Model Name	Doro Liberto 825
FCC ID	WS5DORO825E
EUT supports Radios application	GSM/GPRS/EGPRS/WCDMA/HSPA/ HSPA+(Downlink Only)/DC-HSDPA/LTE/NFC WLAN 2.4GHz 802.11b/g/n HT20/ Bluetooth v3.0 + EDR/Bluetooth v4.1 LE
IMEI Code	Conducted: 358900060007720 Radiation: 358900060008868 Conduction: 358900060008868
HW Version	Doro_DVT2
SW Version	825A_EU_RET_00.31.02_USER_150722
EUT Stage	Identical Prototype

Remark: The above EUT's information was declared by manufacturer. Please refer to the specifications or user's manual for more detailed description.

## 1.4 Product Specification subjective to this standard

Product Specification subjective to this standard	
Tx/Rx Channel Frequency Range	802.11b/g/n : 2412 MHz ~ 2462 MHz
Maximum (Peak) Output Power to Antenna	802.11b : 19.16 dBm (0.0824 W) 802.11g : 23.39 dBm (0.2183 W) 802.11n HT20 : 23.31 dBm (0.2143 W)
Antenna Type / Gain	802.11b/g/n : PIFA Antenna with gain -1.5 dBi
Type of Modulation	802.11b : DSSS (DBPSK / DQPSK / CCK) 802.11g/n : OFDM (BPSK / QPSK / 16QAM / 64QAM)



### 1.5 Modification of EUT

No modifications are made to the EUT during all test items.

### 1.6 Testing Location

<b>Test Site</b>	SPORTON INTERNATIONAL (KUNSHAN) INC.			
<b>Test Site Location</b>	No. 3-2, PingXiang Road, Kunshan, Jiangsu Province, P. R. China TEL: +86-0512-5790-0158 FAX: +86-0512-5790-0958			
<b>Test Site No.</b>	<b>Sporton Site No.</b>			<b>FCC Registration No.</b>
	TH01-KS	CO01-KS	03CH02-KS	418269

**Note:** The test site complies with ANSI C63.4 2009 requirement.

### 1.7 Applicable Standards

According to the specifications of the manufacturer, the EUT must comply with the requirements of the following standards:

- ♦ FCC Part 15 Subpart C §15.247
- ♦ FCC KDB Publication No. 558074 D01 DTS Meas. Guidance v03r03
- ♦ ANSI C63.10-2013

**Remark:**

1. All test items were verified and recorded according to the standards and without any deviation during the test.
2. FCC permits the use of the 1.5 meter table as an alternative in C63.10-2013 through inquiry tracking number 961829.



## 2 Test Configuration of Equipment Under Test

The EUT has been associated with peripherals and configuration operated in a manner tended to maximize its emission characteristics in a typical application. Frequency range investigated: conducted emission (150 kHz to 30 MHz) and radiated emission (9 kHz to the 10th harmonic of the highest fundamental frequency or to 40 GHz, whichever is lower). For radiated measurement, pre-scanned in three orthogonal panels, X, Y, Z. The worst cases (Z plane) were recorded in this report.

The final configuration from all the combinations and the worst-case data rates were investigated by measuring the maximum power across all the data rates and modulation modes under section 2.2.

Based on the worst configuration found above, the RF power setting is set individually to meet FCC compliance limit for the final conducted and radiated tests shown in section 2.3.

### 2.1 Carrier Frequency Channel

Frequency Band	Channel	Freq. (MHz)	Channel	Freq. (MHz)
2400-2483.5 MHz	1	2412	7	2442
	2	2417	8	2447
	3	2422	9	2452
	4	2427	10	2457
	5	2432	11	2462
	6	2437	-	-



## 2.2 Pre-Scanned RF Power

Preliminary tests were performed in different data rate and data rate associated with the highest power were chosen for full test shown in the following tables.

2.4GHz 802.11b RF Output Power (dBm)						
Power vs. Channel			Power vs. Data Rate			
Channel	Frequency (MHz)	Data Rate 1Mbps	Channel	2Mbps	5.5Mbps	11Mbps
CH 01	2412 MHz	18.68	CH 06	18.82	18.81	18.69
CH 06	2437 MHz	19.16				
CH 11	2462 MHz	18.57				

2.4GHz 802.11g RF Output Power (dBm)										
Power vs. Channel			Power vs. Data Rate							
Channel	Frequency (MHz)	Data Rate 6Mbps	Channel	9Mbps	12Mbps	18Mbps	24Mbps	36Mbps	48Mbps	54Mbps
CH 01	2412 MHz	22.63	CH 06	23.20	23.12	23.15	23.36	23.32	23.22	23.10
CH 06	2437 MHz	23.39								
CH 11	2462 MHz	22.13								

2.4GHz 802.11n HT20 RF Output Power (dBm)										
Power vs. Channel			Power vs. MCS Index							
Channel	Frequency (MHz)	MCS Index MCS0	Channel	MCS1	MCS2	MCS3	MCS4	MCS5	MCS6	MCS7
CH 01	2412 MHz	22.93	CH 06	23.18	23.11	23.24	23.08	23.12	23.28	23.26
CH 06	2437 MHz	23.31								
CH 11	2462 MHz	22.20								





### 2.3 Test Mode

Final test mode of conducted test items and radiated spurious emissions are considering the modulation and worse data rates from the power table described in section 2.2.

<2.4GHz>

Modulation	Data Rate
802.11b	1 Mbps
802.11g	6 Mbps
802.11n HT20	MCS0

Test Cases	
AC Conducted Emission	Mode 1 : GSM850 Idle + Bluetooth Link + WLAN Link + Earphone + USB Cable 1 (Charging from Adapter)
<b>Remark:</b> For radiated test cases, WIFI 802.11b/g were performed with adapter, earphone, USB cable 1 and cradle; WIFI 802.11n HT20 was performed with adapter, earphone and USB cable 1.	

## 2.4 Connection Diagram of Test System

### <WLAN 802.11b/g Tx Mode>

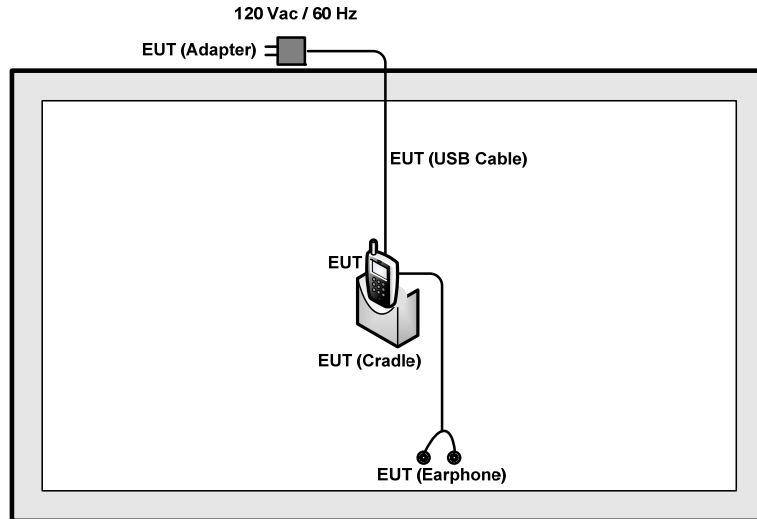

### <WLAN 802.11n HT20 Tx Mode>

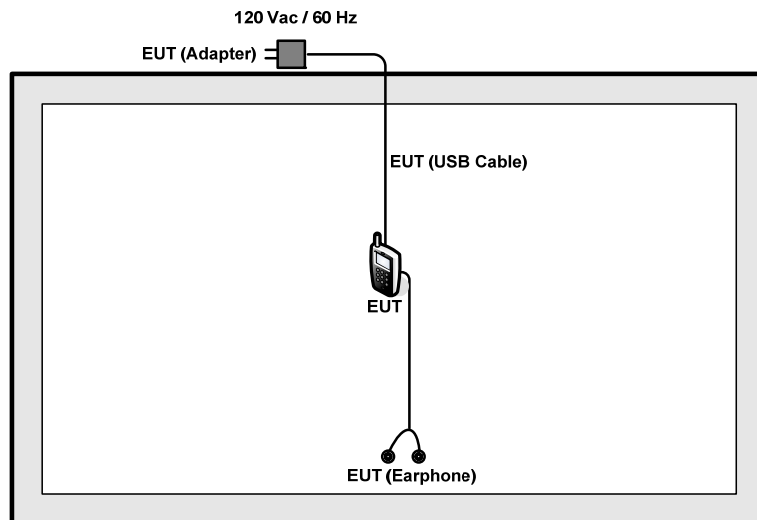

<AC Conducted Emission Mode>

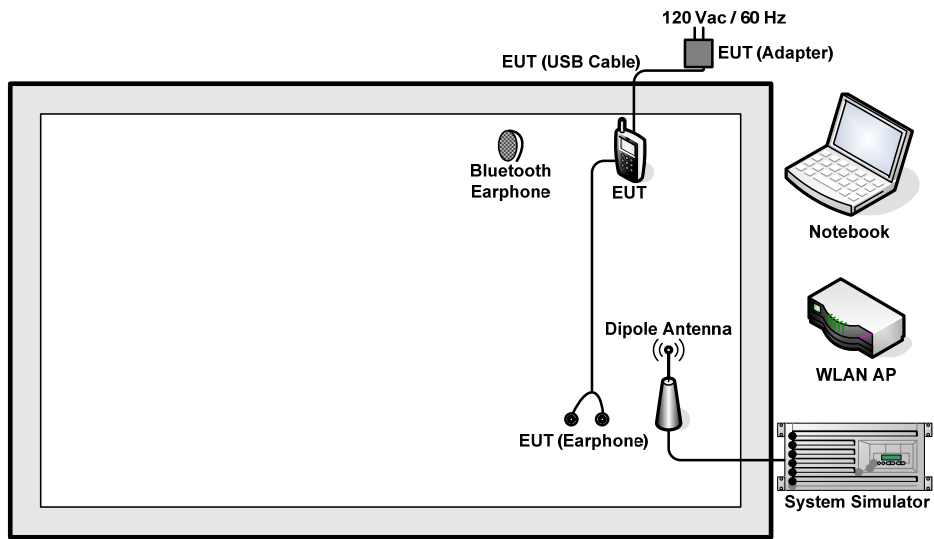



## 2.5 Support Unit used in test configuration and system

Item	Equipment	Trade Name	Model Name	FCC ID	Data Cable	Power Cord
1.	System Simulator	R&S	CMU 200	N/A	N/A	Unshielded, 1.8 m
2.	WLAN AP	LINKSYS	WRT600N	Q87-WRT600NV11	N/A	Unshielded, 1.8 m
3.	Notebook	Lenovo	G480	PRC4	N/A	shielded cable DC O/P 1.8 m unshielded AC I/P cable 1.8 m
4.	Bluetooth Earphone	Nokia	BH-106	QTLBH-106	N/A	N/A

## 2.6 EUT Operation Test Setup

For WLAN RF test items, an engineering test program was provided and enabled to make EUT continuously transmit/receive.

For AC power line conducted emissions, the EUT was set to connect with the WLAN AP under large package sizes transmission.



## 2.7 Measurement Results Explanation Example

For all conducted test items:

The offset level is set in the spectrum analyzer to compensate the RF cable loss between EUT conducted output port and spectrum analyzer. With the offset compensation, the spectrum analyzer reading level is exactly the EUT RF output level.

Example :

The spectrum analyzer offset is derived from RF cable loss.

*Offset = RF cable loss.*

Following shows an offset computation example with cable loss 6 dB.

$$\begin{aligned} \text{Offset(dB)} &= \text{RF cable loss(dB)}. \\ &= 6 \text{ (dB)} \end{aligned}$$

### 3 Test Result

#### 3.1 6dB Bandwidth Measurement

##### 3.1.1 Limit of 6dB Bandwidth

The minimum 6 dB bandwidth shall be at least 500 kHz.

##### 3.1.2 Measuring Instruments

The measuring equipment is listed in the section 4 of this test report.

##### 3.1.3 Test Procedures

1. The testing follows FCC KDB Publication No. 558074 DTS D01 Meas. Guidance v03r03.
2. The RF output of EUT was connected to the spectrum analyzer by RF cable and attenuator. The path loss was compensated to the results for each measurement.
3. Set to the maximum power setting and enable the EUT transmit continuously.
4. Make the measurement with the spectrum analyzer's resolution bandwidth (RBW) = 100 kHz. Set the Video bandwidth (VBW) = 300 kHz. In order to make an accurate measurement. The 6 dB bandwidth must be greater than 500 kHz.
5. Measure and record the results in the test report.

##### 3.1.4 Test Setup

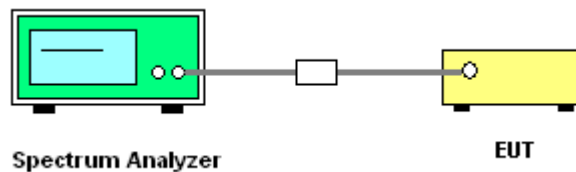



### 3.1.5 Test Result of 6dB Occupied Bandwidth

Please refer to Appendix A of this test report.

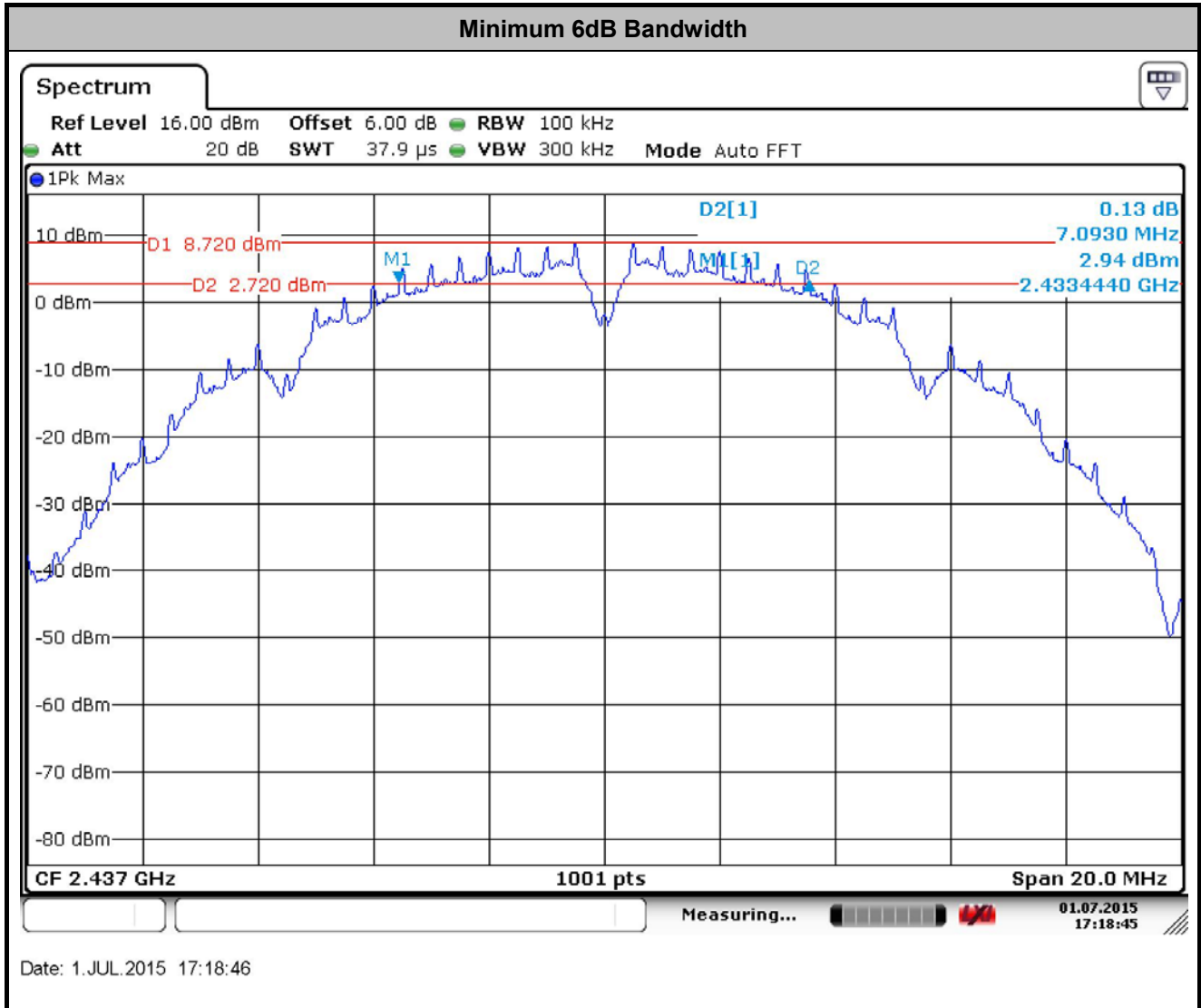

Note : The occupied channel bandwidth is maintained within the band of operation for all of the modulations.

## 3.2 Output Power Measurement

### 3.2.1 Limit of Output Power

For systems using digital modulation in the 2400-2483.5MHz, the limit for peak output power is 30dBm. If transmitting Antenna of directional gain greater than 6dBi are used the peak output power from the intentional radiator shall be reduced below the above stated value by the amount in dB that the directional gain of the Antenna exceeds 6 dBi. In case of point-to-point operation, the limit has to be reduced by 1dB for every 3dB that the directional gain of the Antenna exceeds 6dBi.

### 3.2.2 Measuring Instruments

The measuring equipment is listed in the section 4 of this test report.

### 3.2.3 Test Procedures

1. The testing follows the Measurement Procedure of FCC KDB No. 558074 DTS D01 Meas. Guidance v03r03.
2. The RF output of EUT was connected to the power meter by RF cable and attenuator. The path loss was compensated to the results for each measurement.
3. Set to the maximum power setting and enable the EUT transmit continuously.
4. Measure the conducted output power and record the results in the test report.

### 3.2.4 Test Setup

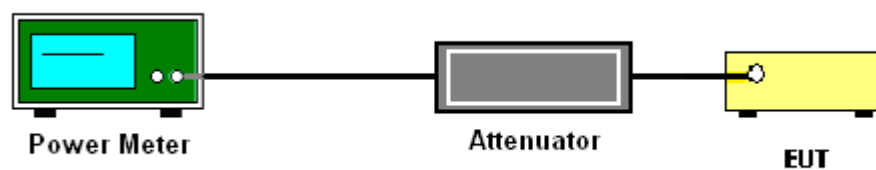





### **3.2.5 Test Result of Peak Output Power**

Please refer to Appendix A of this test report.

### **3.2.6 Test Result of Average output Power (Reporting Only)**

Please refer to Appendix A of this test report.

### 3.3 Power Spectral Density Measurement

#### 3.3.1 Limit of Power Spectral Density

The peak power spectral density shall not be greater than 8dBm in any 3kHz band at any time interval of continuous transmission.

#### 3.3.2 Measuring Instruments

The measuring equipment is listed in the section 4 of this test report.

#### 3.3.3 Test Procedures

1. The testing follows Measurement Procedure 10.2 Method PKPSD of FCC KDB Publication No. 558074 D01 DTS Meas. Guidance v03r03
2. The RF output of EUT was connected to the spectrum analyzer by RF cable and attenuator. The path loss was compensated to the results for each measurement.
3. Set to the maximum power setting and enable the EUT transmit continuously.
4. Make the measurement with the spectrum analyzer's resolution bandwidth (RBW) = 3 kHz. Video bandwidth VBW = 10 kHz In order to make an accurate measurement, set the span to 1.5 times DTS Channel Bandwidth. (6dB BW)
5. Detector = peak, Sweep time = auto couple, Trace mode = max hold, Allow trace to fully stabilize. Use the peak marker function to determine the maximum power level.
6. Measure and record the results in the test report.

#### 3.3.4 Test Setup

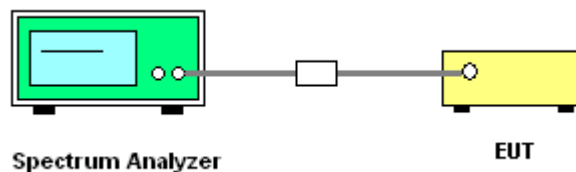



### 3.3.5 Test Result of Power Spectral Density

Please refer to Appendix A of this test report.

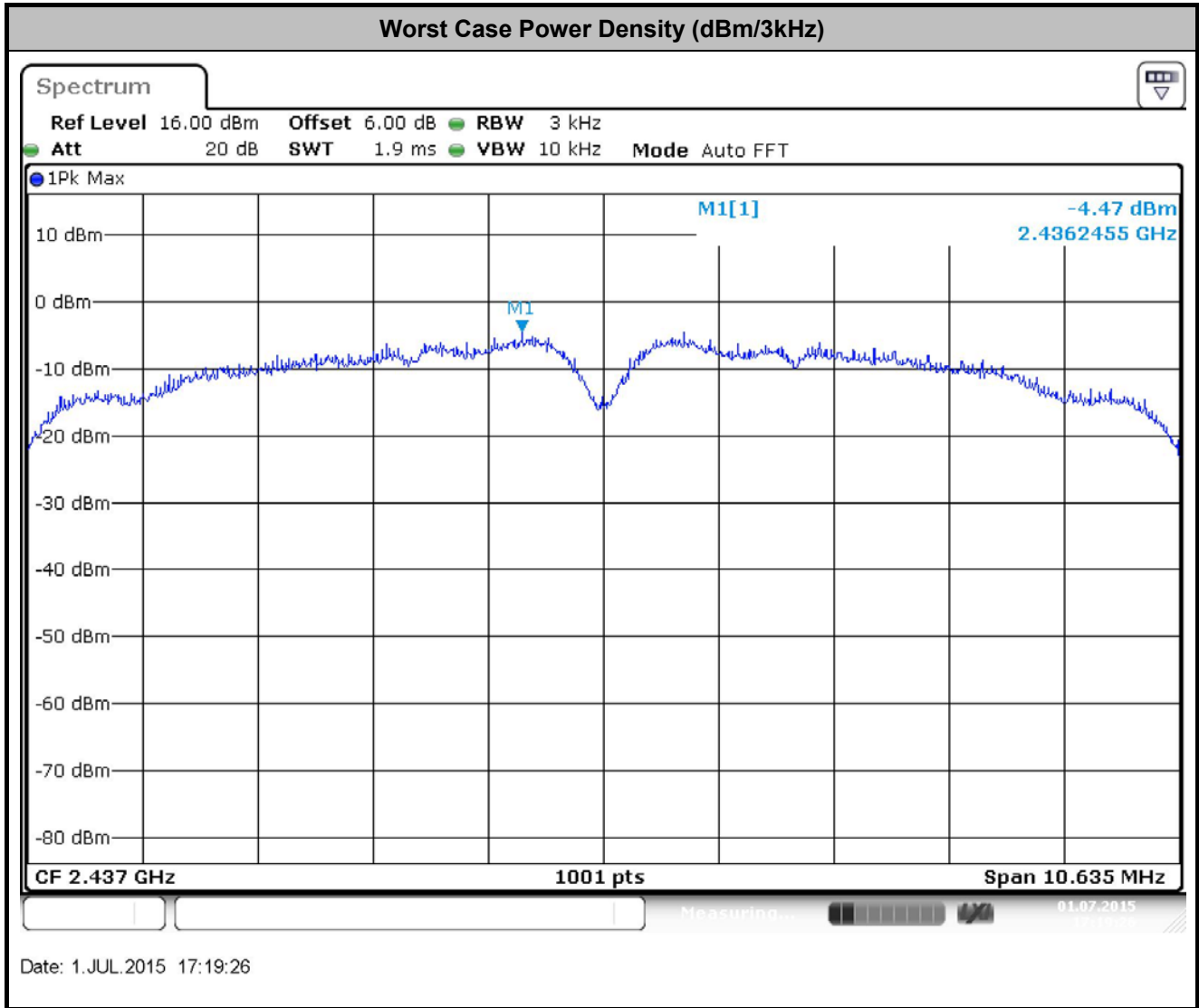

## 3.4 Conducted Band Edges and Spurious Emission Measurement

### 3.4.1 Limit of Conducted Band Edges and Spurious Emission Measurement

In any 100 kHz bandwidth outside of the authorized frequency band, the emissions which fall in the non-restricted bands shall be attenuated at least 20 dB / 30dB relative to the maximum PSD level in 100 kHz by RF conducted measurement and radiated emissions which fall in the restricted bands, as defined in Section 15.205(a), must also comply with the radiated emission limits specified in Section 15.209(a).

### 3.4.2 Measuring Instruments

The measuring equipment is listed in the section 4 of this test report.

### 3.4.3 Test Procedures

1. The testing follows FCC KDB Publication No. 558074 D01 DTS Meas. Guidance v03r03.
2. The RF output of EUT was connected to the spectrum analyzer by RF cable and attenuator. The path loss was compensated to the results for each measurement.
3. Set to the maximum power setting and enable the EUT transmit continuously.
4. Set RBW = 100 kHz, VBW=300 kHz, Peak Detector. Unwanted Emissions measured in any 100 kHz bandwidth outside of the authorized frequency band shall be attenuated by at least 20 dB relative to the maximum in-band peak PSD level in 100 kHz when maximum peak conducted output power procedure is used. If the transmitter complies with the conducted power limits based on the use of RMS averaging over a time interval, the attenuation required under this paragraph shall be 30 dB instead of 20 dB per 15.247(d).
5. Measure and record the results in the test report.
6. The RF fundamental frequency should be excluded against the limit line in the operating frequency band.

### 3.4.4 Test Setup

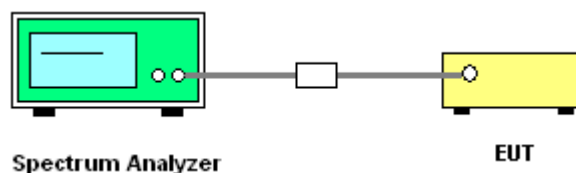



### 3.4.5 Test Result of Conducted Band Edges and Spurious Emission

Test Mode :	802.11b	Temperature :	24~25°C
Test Band :	2.4GHz Low	Relative Humidity :	49~51%
Test Channel :	01	Test Engineer :	Issac Song

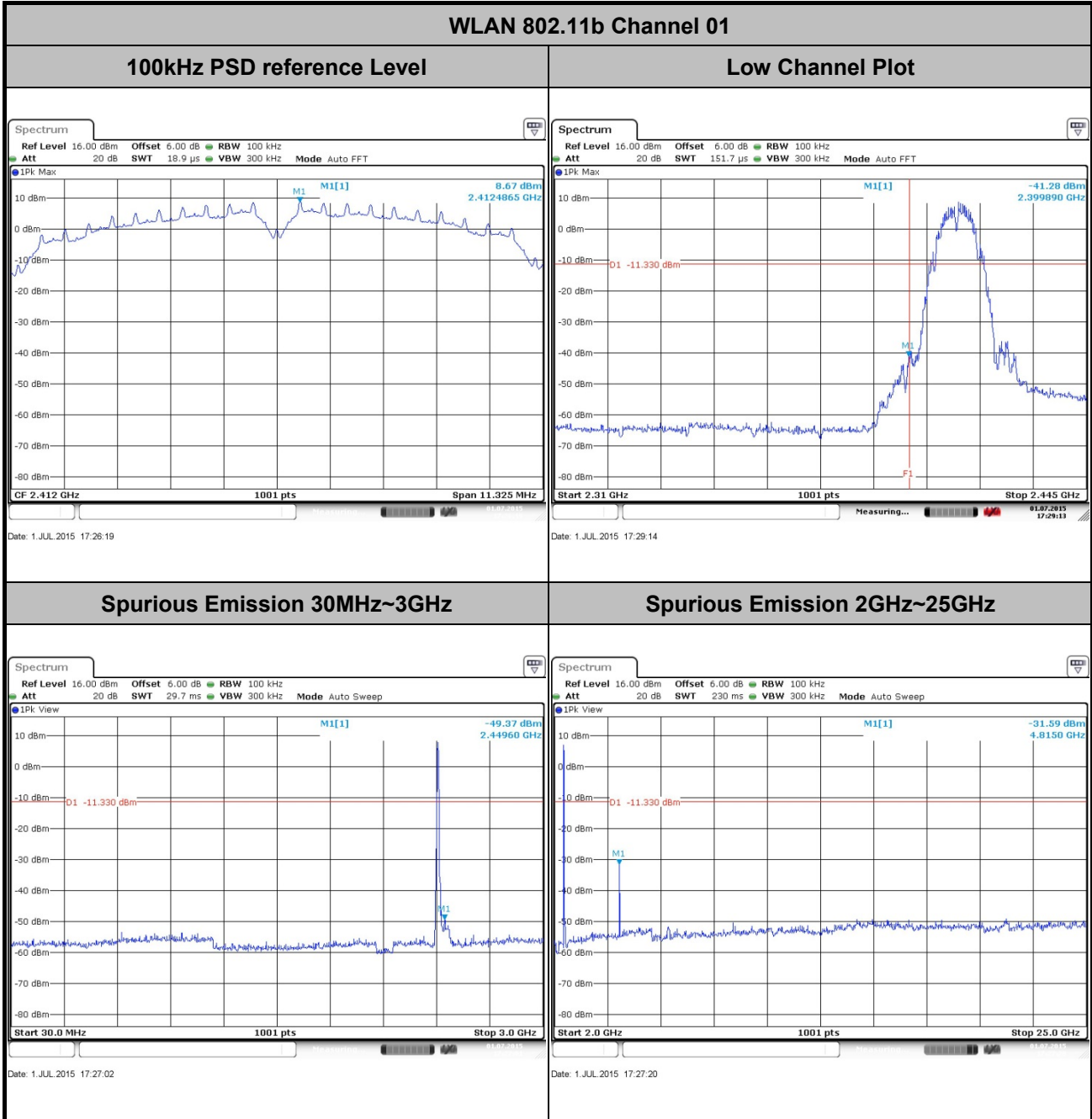



Test Mode :	802.11b	Temperature :	24~25°C
Test Band :	2.4GHz Mid	Relative Humidity :	49~51%
Test Channel :	06	Test Engineer :	Issac Song

WLAN 802.11b Channel 06

100kHz PSD reference Level

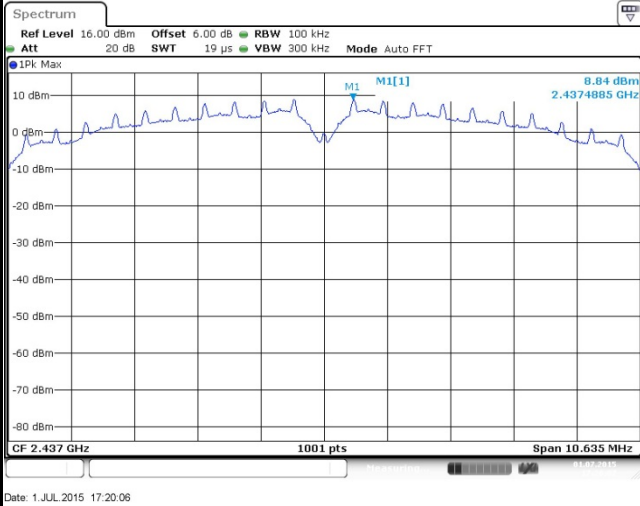

Spurious Emission 30MHz~3GHz

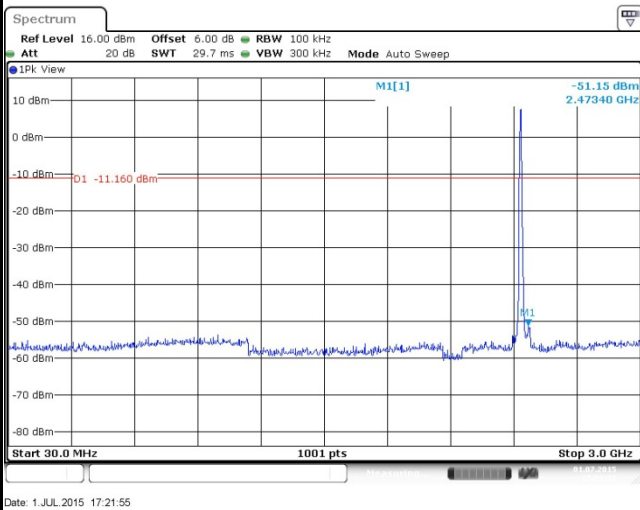

Spurious Emission 2GHz~25GHz

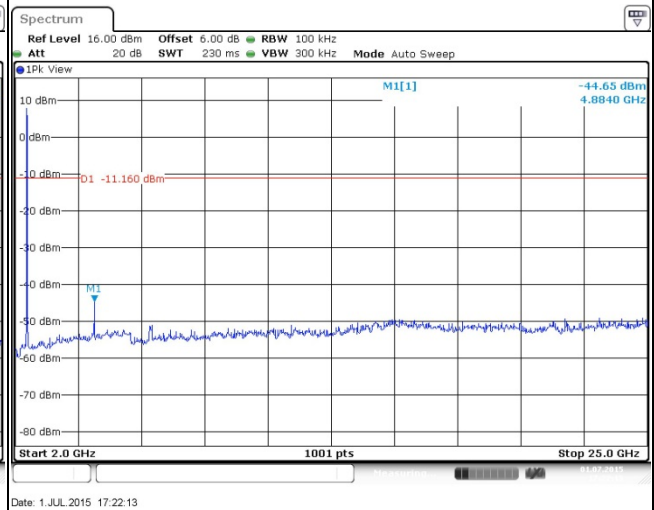



Test Mode :	802.11b	Temperature :	24~25°C
Test Band :	2.4GHz High	Relative Humidity :	49~51%
Test Channel :	11	Test Engineer :	Issac Song

WLAN 802.11b Channel 11

100kHz PSD reference Level

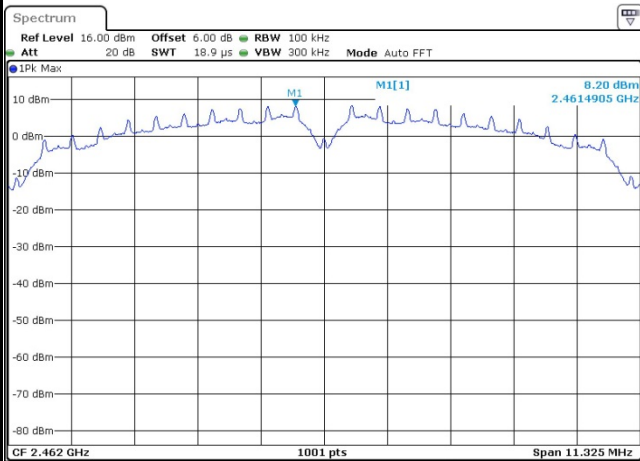

Date: 1.JUL.2015 17:14:34

High Channel Plot

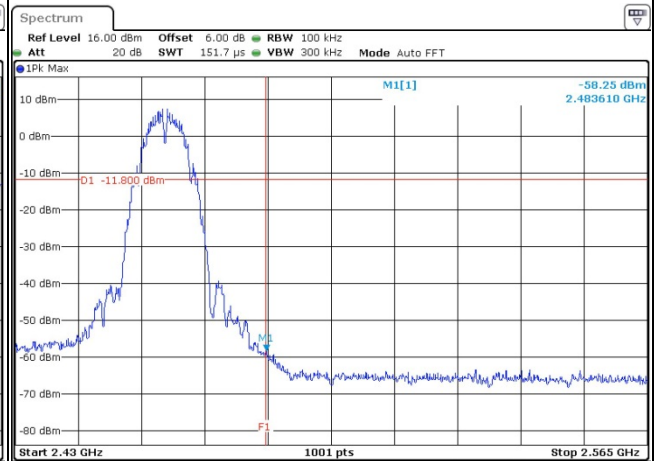

Date: 1.JUL.2015 17:14:49

Spurious Emission 30MHz~3GHz

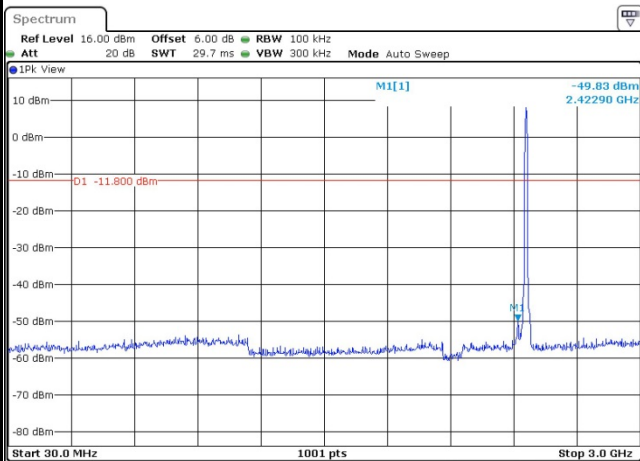

Date: 1.JUL.2015 17:15:10

Spurious Emission 2GHz~25GHz

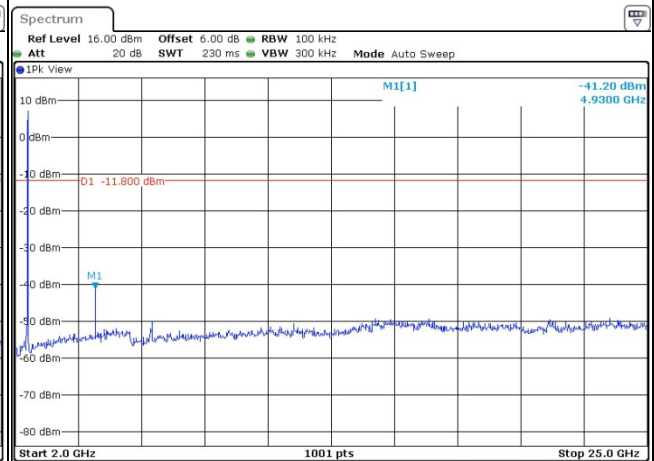

Date: 1.JUL.2015 17:15:28



Test Mode :	802.11g	Temperature :	24~25°C
Test Band :	2.4GHz Low	Relative Humidity :	49~51%
Test Channel :	01	Test Engineer :	Issac Song

WLAN 802.11g Channel 01

100kHz PSD reference Level

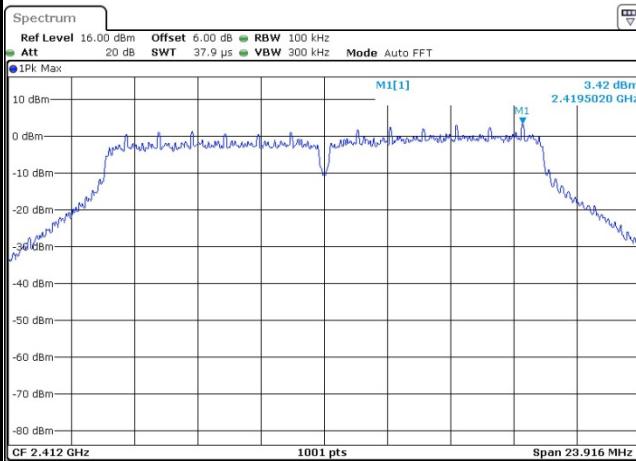

Date: 17 JUN 2015 14:39:32

Low Channel Plot

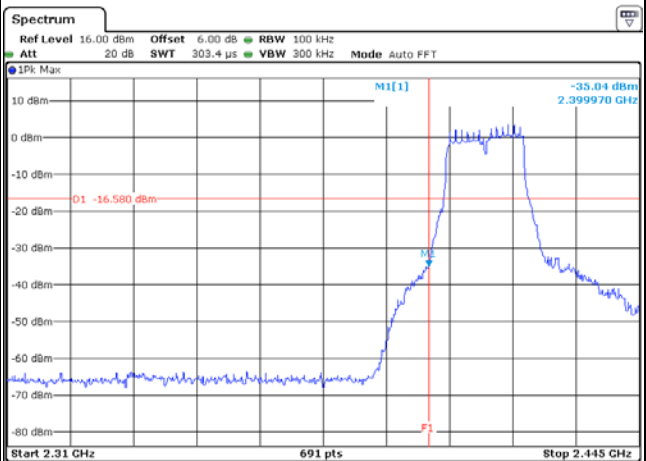

Date: 4 JUL 2015 16:36:37

Spurious Emission 30MHz~3GHz

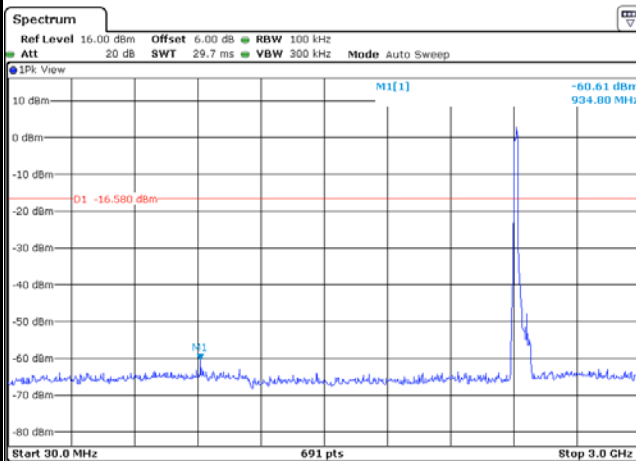

Date: 4 JUL 2015 16:38:38

Spurious Emission 2GHz~25GHz

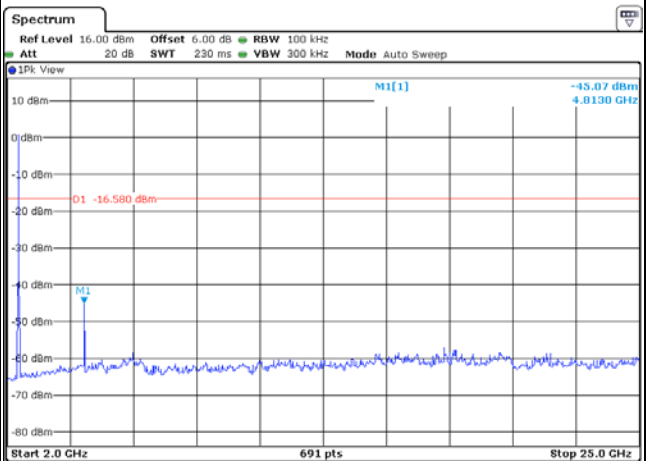

Date: 4 JUL 2015 16:39:32





Test Mode :	802.11g	Temperature :	24~25°C
Test Band :	2.4GHz Mid	Relative Humidity :	49~51%
Test Channel :	06	Test Engineer :	Issac Song

WLAN 802.11g Channel 06

100kHz PSD reference Level

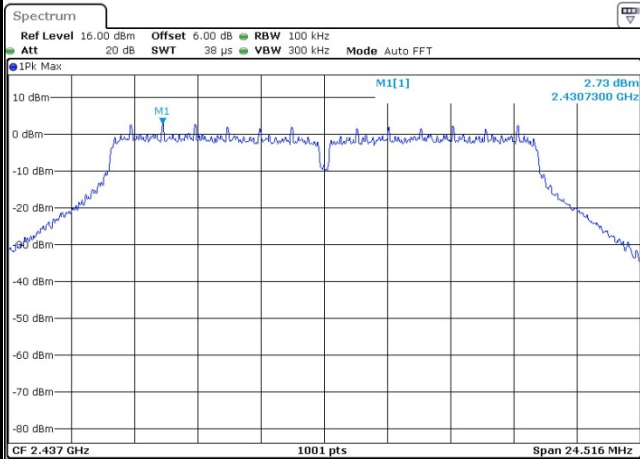

Date: 17 JUN 2015 14:53:26

Spurious Emission 30MHz~3GHz

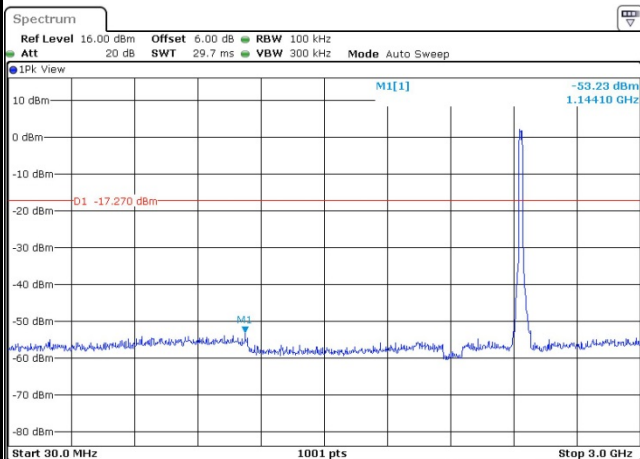

Date: 17 JUN 2015 14:53:47

Spurious Emission 2GHz~25GHz

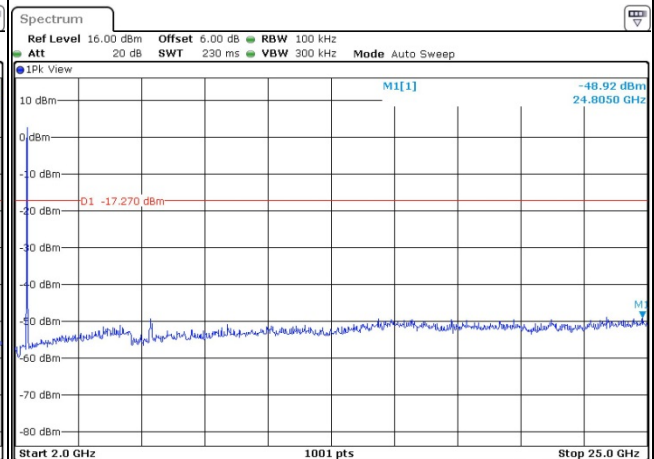

Date: 17 JUN 2015 14:54:05



Test Mode :	802.11g	Temperature :	24~25°C
Test Band :	2.4GHz High	Relative Humidity :	49~51%
Test Channel :	11	Test Engineer :	Issac Song

WLAN 802.11g Channel 11

100kHz PSD reference Level	High Channel Plot
----------------------------	-------------------

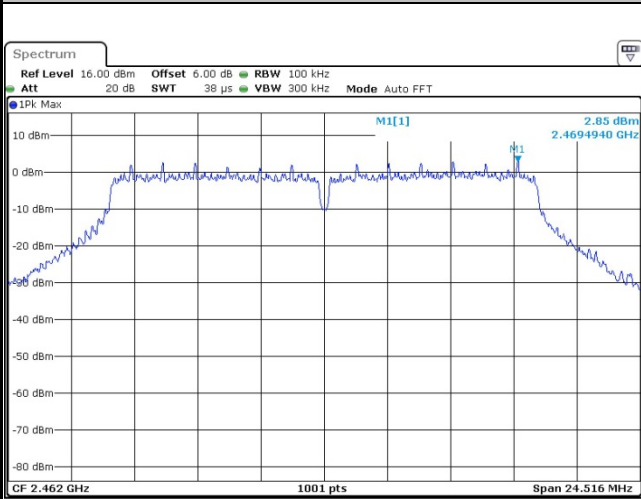

Date: 17 JUN 2015 14:57:55

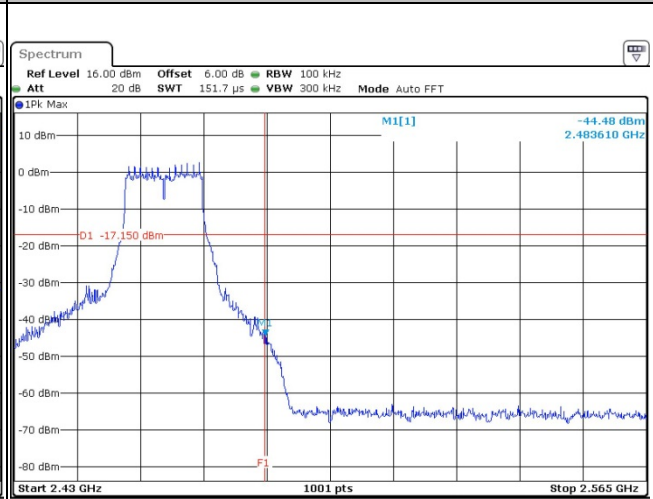

Date: 17 JUN 2015 14:58:12

Spurious Emission 30MHz~3GHz

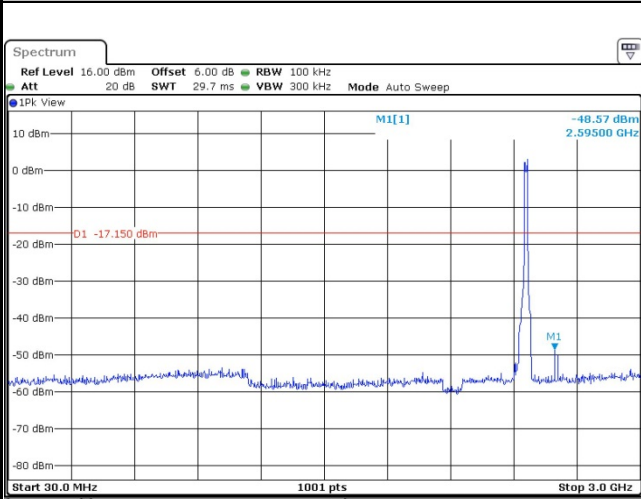

Date: 17 JUN 2015 15:00:04

Spurious Emission 2GHz~25GHz

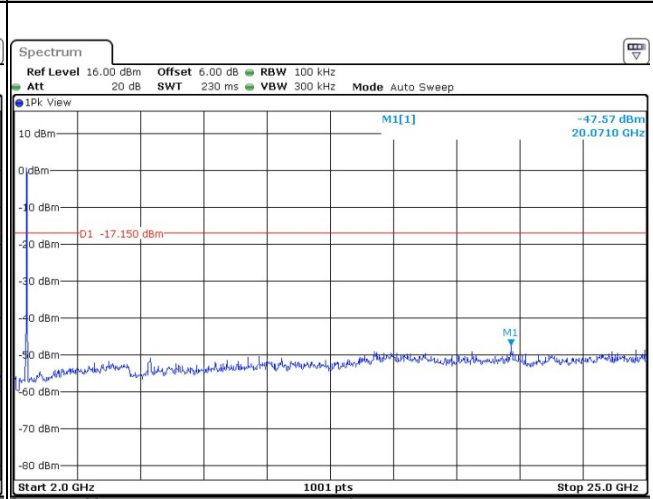

Date: 17 JUN 2015 15:00:22



Test Mode :	802.11n HT20	Temperature :	24~25°C
Test Band :	2.4GHz Low	Relative Humidity :	49~51%
Test Channel :	01	Test Engineer :	Issac Song

WLAN 802.11n HT20 Channel 01

100kHz PSD reference Level	Low Channel Plot
----------------------------	------------------

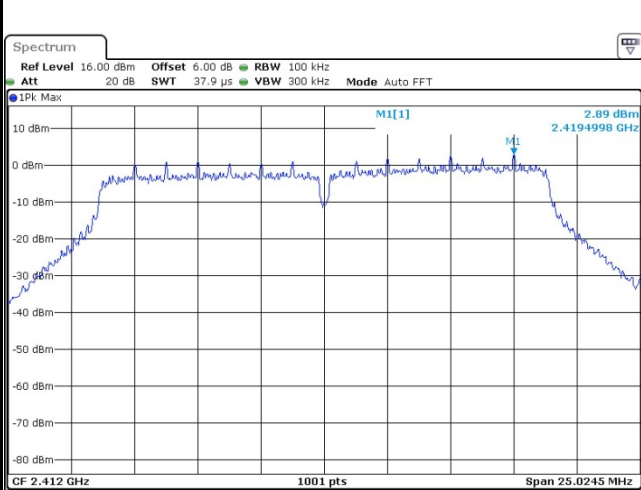

Date: 17 JUN 2015 15:11:57

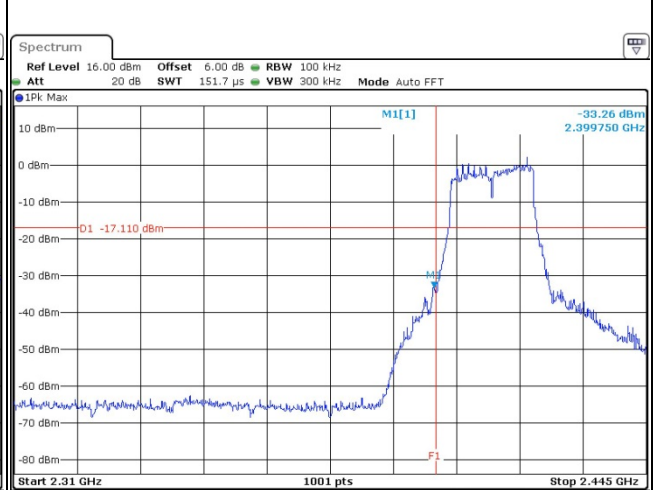

Date: 17 JUN 2015 15:12:21

Spurious Emission 30MHz~3GHz

Spurious Emission 2GHz~25GHz

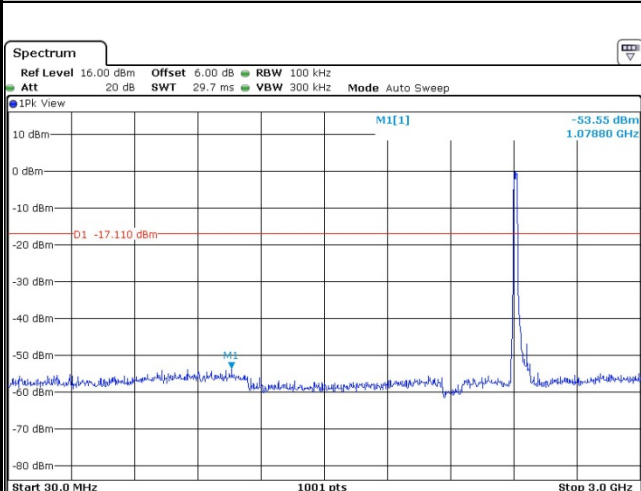

Date: 17 JUN 2015 15:15:13

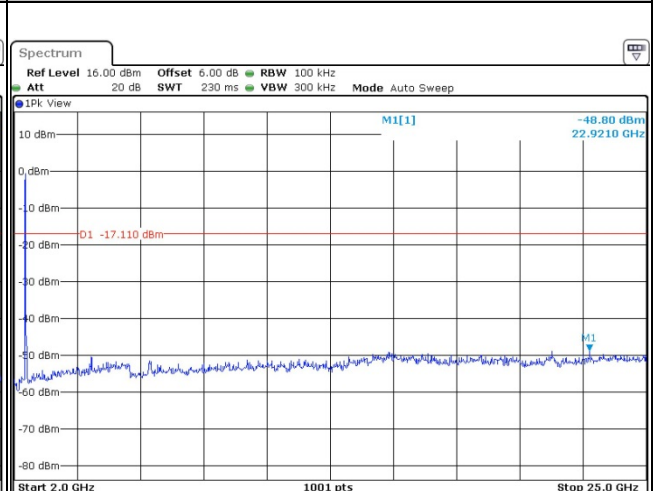

Date: 17 JUN 2015 15:14:04



Test Mode :	802.11n HT20	Temperature :	24~25°C
Test Band :	2.4GHz Mid	Relative Humidity :	49~51%
Test Channel :	06	Test Engineer :	Issac Song

WLAN 802.11n HT20 Channel 06

100kHz PSD reference Level

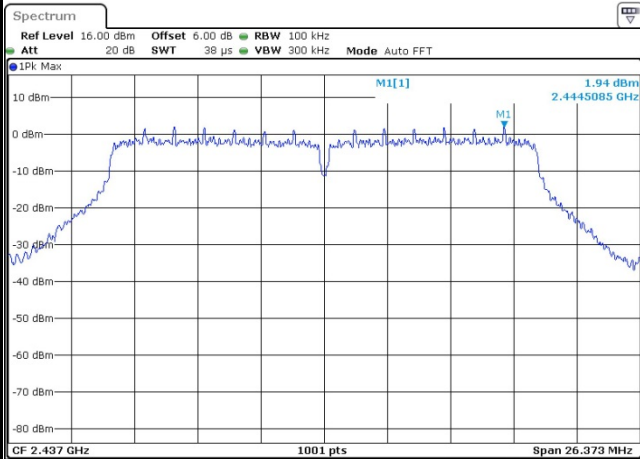

Date: 17 JUN 2015 15:26:52

Spurious Emission 30MHz~3GHz

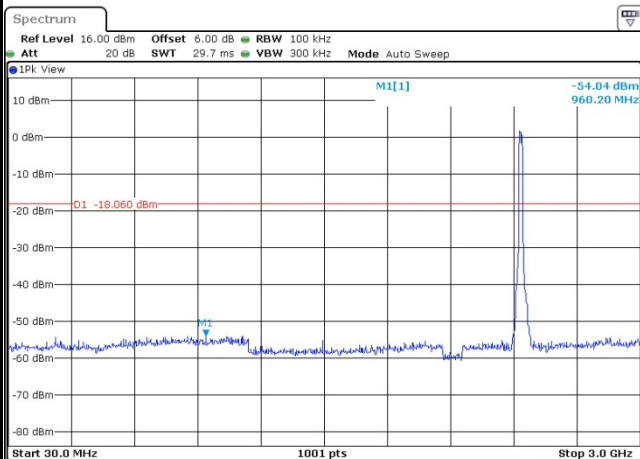

Date: 17 JUN 2015 15:27:15

Spurious Emission 2GHz~25GHz

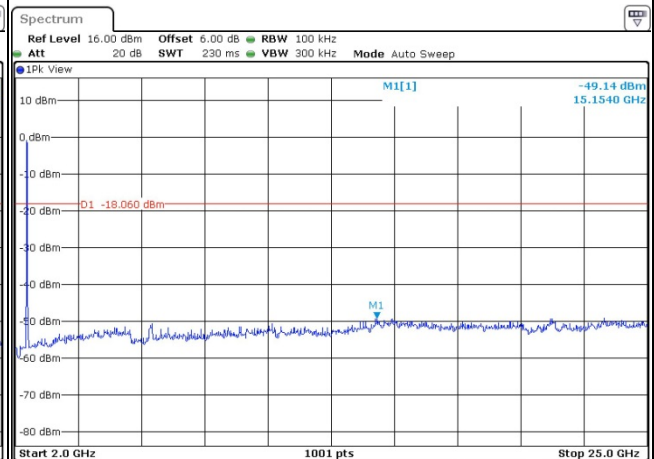

Date: 17 JUN 2015 15:27:33



Test Mode :	802.11n HT20	Temperature :	24~25°C
Test Band :	2.4GHz High	Relative Humidity :	49~51%
Test Channel :	11	Test Engineer :	Issac Song

WLAN 802.11n HT20 Channel 11

100kHz PSD reference Level

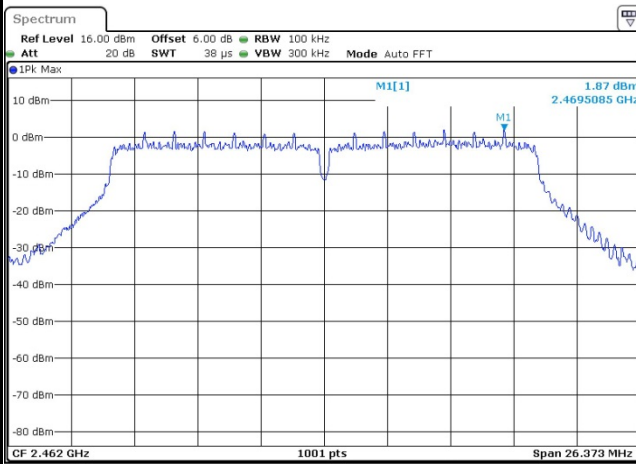

Date: 17 JUN 2015 15:31:20

High Channel Plot

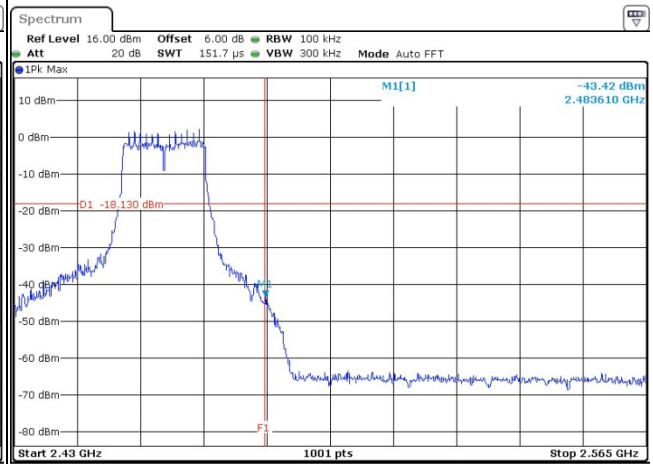

Date: 17 JUN 2015 15:31:37

Spurious Emission 30MHz~3GHz

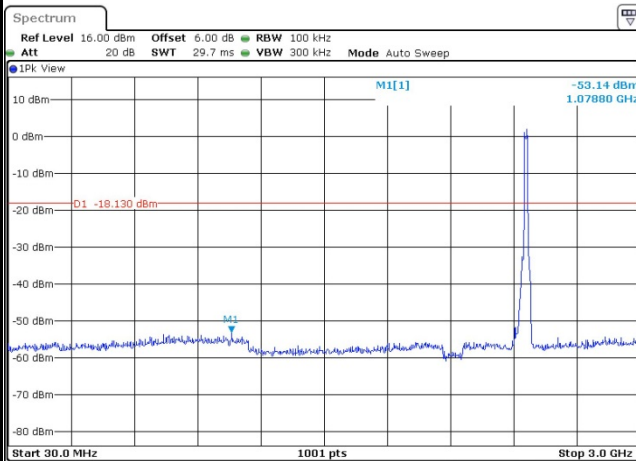

Date: 17 JUN 2015 15:33:50

Spurious Emission 2GHz~25GHz

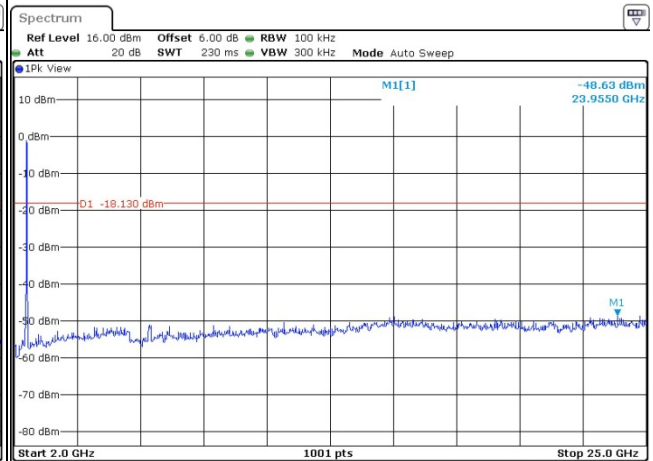

Date: 17 JUN 2015 15:34:07



### 3.5 Radiated Band Edges and Spurious Emission Measurement

#### 3.5.1 Limit of Radiated band edge and Spurious Emission Measurement

In any 100 kHz bandwidth outside the intentional radiator frequency band, all harmonics/spurious must be at least 20 dB below the highest emission level within the authorized band. If the output power of this device was measured by spectrum analyzer, the attenuation under this paragraph shall be 30 dB instead of 20 dB. In addition, radiated emissions which fall in the restricted bands must also comply with the FCC section 15.209 limits as below.

Frequency (MHz)	Field Strength (microvolts/meter)	Measurement Distance (meters)
0.009 – 0.490	2400/F(kHz)	300
0.490 – 1.705	24000/F(kHz)	30
1.705 – 30.0	30	30
30 – 88	100	3
88 – 216	150	3
216 - 960	200	3
Above 960	500	3

#### 3.5.2 Measuring Instruments

The measuring equipment is listed in the section 4 of this test report.



3.5.3 Test Procedures

1. The testing follows FCC KDB Publication No. 558074 D01 DTS Meas. Guidance v03r03.
2. The EUT was arranged to its worst case and then tune the antenna tower (from 1 m to 4 m) and turntable (from 0 degree to 360 degrees) to find the maximum reading. A pre-amp and a high pass filter are used for the test in order to get better signal level.
3. The EUT was placed on a turntable with 0.8 meter for frequency below 1GHz and 1.5 meter for frequency above 1GHz respectively above ground.
4. The EUT was set 3 meters from the interference receiving antenna, which was mounted on the top of a variable height antenna tower.
5. Corrected Reading: Antenna Factor + Cable Loss + Read Level - Preamp Factor = Level
6. For measurement below 1GHz, If the emission level of the EUT measured by the peak detector is 3 dB lower than the applicable limit, the peak emission level will be reported. Otherwise, the emission measurement will be repeated using the quasi-peak detector and reported.
7. Use the following spectrum analyzer settings:
  - (1) Span shall wide enough to fully capture the emission being measured;
  - (2) Set RBW=100 kHz for  $f < 1 \text{ GHz}$ ;  $\text{VBW} \geq \text{RBW}$ ; Sweep = auto; Detector function = peak; Trace = max hold;
  - (3) Set RBW = 1 MHz, VBW= 3MHz for  $f \geq 1 \text{ GHz}$  for peak measurement.
 

For average measurement:

    - $\text{VBW} = 10 \text{ Hz}$ , when duty cycle is no less than 98 percent.
    - $\text{VBW} \geq 1/T$ , when duty cycle is less than 98 percent where T is the minimum transmission duration over which the transmitter is on and is transmitting at its maximum power control level for the tested mode of operation.

Band	Duty Cycle(%)	T(ms)	1/T(kHz)	VBW Setting
802.11b	97.630	8.24	0.121	300Hz
802.11g	87.261	1.37	0.730	1kHz
2.4GHz 802.11n HT20	86.523	1.284	0.779	1kHz

### 3.5.4 Test Setup

For radiated emissions below 30MHz

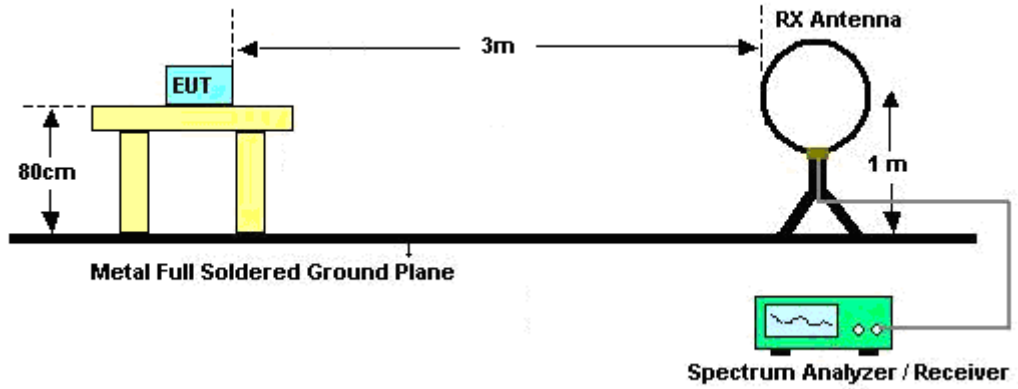

For radiated emissions from 30MHz to 1GHz

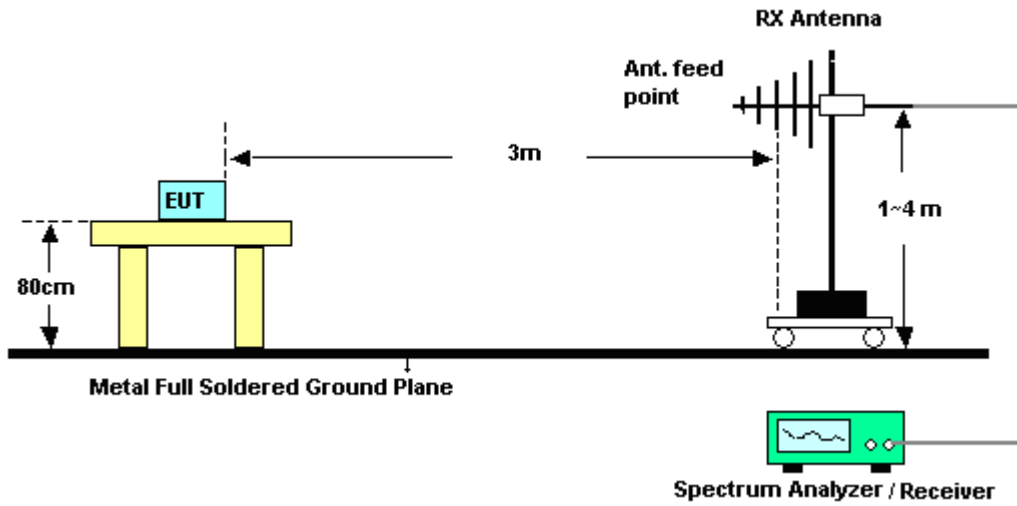



For radiated emissions above 1GHz

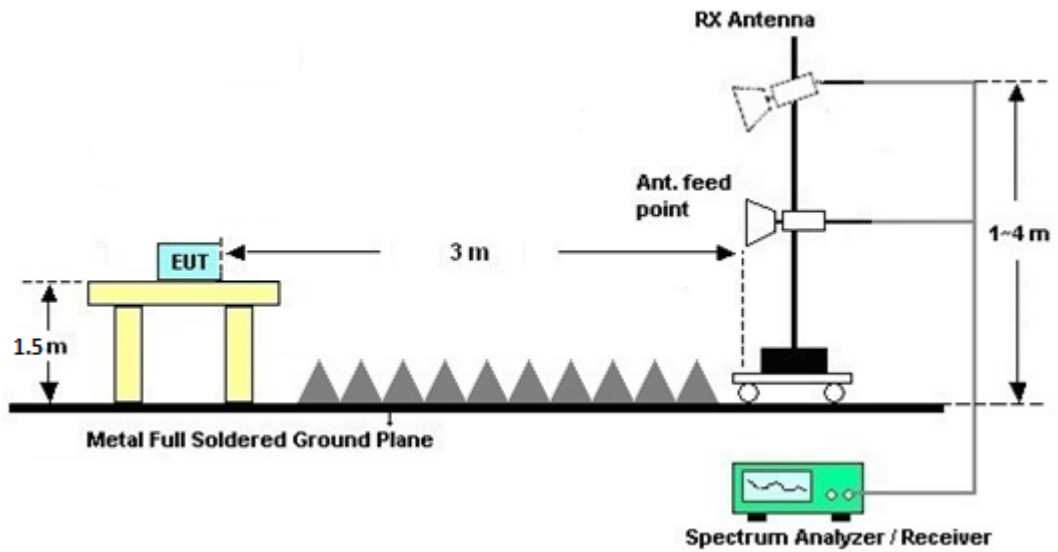

### 3.5.5 Test Results of Radiated Spurious Emissions (9kHz ~ 30MHz)

The low frequency, which started from 9 kHz to 30MHz, was pre-scanned and the result which was 20dB lower than the limit line per 15.31(o) was not reported.

### 3.5.6 Test Result of Radiated Spurious at Band Edges

Please refer to Appendix B.

### 3.5.7 Test Result of Radiated Spurious Emission (30MHz ~ 10<sup>th</sup> Harmonic)

Please refer to Appendix B.



### 3.6 AC Conducted Emission Measurement

#### 3.6.1 Limit of AC Conducted Emission

For equipment that is designed to be connected to the public utility (AC) power line, the radio frequency voltage that is conducted back onto the AC power line on any frequency or frequencies within the band 150 kHz to 30 MHz shall not exceed the limits in the following table.

Frequency of Emission (MHz)	Conducted Limit (dB $\mu$ V)	
	Quasi-Peak	Average
0.15-0.5	66 to 56*	56 to 46*
0.5-5	56	46
5-30	60	50

\*Decreases with the logarithm of the frequency.

#### 3.6.2 Measuring Instruments

The measuring equipment is listed in the section 4 of this test report.

#### 3.6.3 Test Procedures

1. The EUT was placed 0.4 meter from the conducting wall of the shielding room, and it was kept at least 80 centimeters from any other grounded conducting surface.
2. Connect EUT to the power mains through a line impedance stabilization network (LISN).
3. All the support units are connecting to the other LISN.
4. The LISN provides 50 ohm coupling impedance for the measuring instrument.
5. The FCC states that a 50 ohm, 50 microhenry LISN should be used.
6. Both sides of AC line were checked for maximum conducted interference.
7. The frequency range from 150 kHz to 30 MHz was searched.
8. Set the test-receiver system to Peak Detect Function and specified bandwidth (IF bandwidth = 9kHz) with Maximum Hold Mode.

### 3.6.4 Test Setup

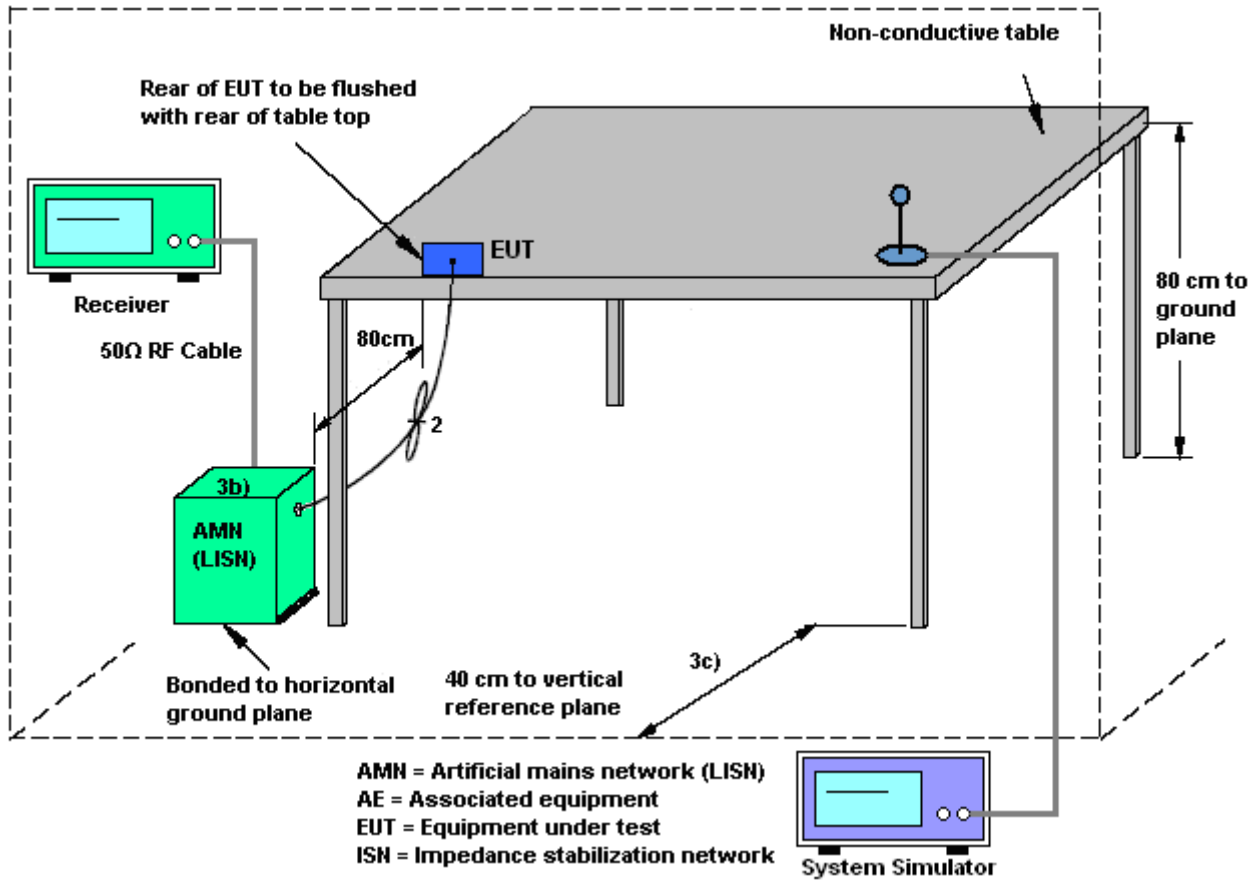



3.6.5 Test Result of AC Conducted Emission

Test Mode :	Mode 1	Temperature :	22~24°C
Test Engineer :	Eko Guan	Relative Humidity :	37~39%
Test Voltage :	120Vac / 60Hz	Phase :	Line
Function Type :	GSM850 Idle + Bluetooth Link + WLAN Link + Earphone + USB Cable 1 (Charging from Adapter)		

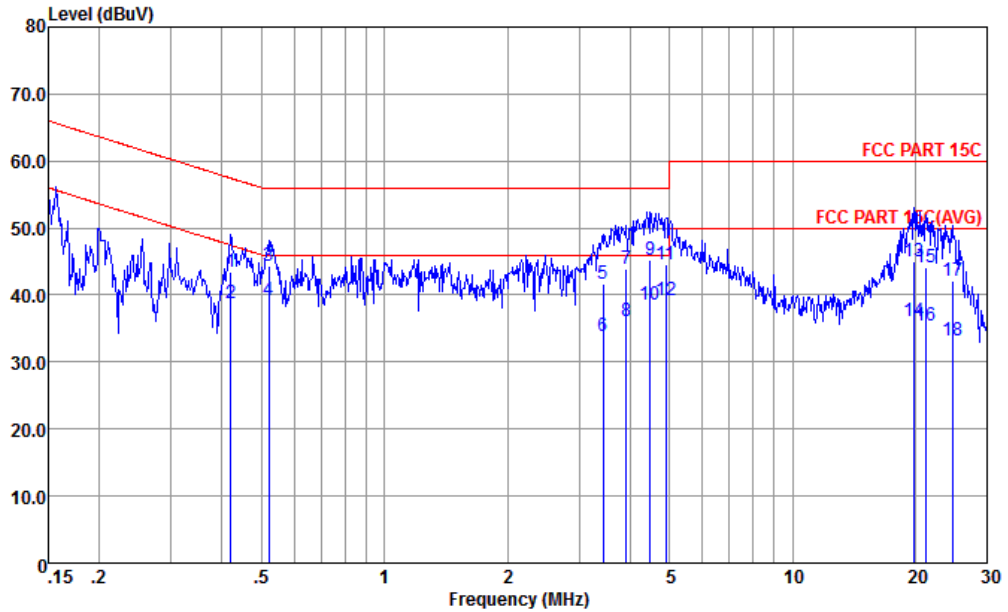

Site : CO01-KS  
 Condition : FCC PART 15C LISN-L20140306 LINE

mode : Mode 1

	Freq	Level	Over Limit	Limit Line	Read Level	LISN Factor	Cable Loss	Remark
	MHz	dBuV	dB	dBuV	dBuV	dB	dB	
1	0.42	43.41	-14.05	57.46	32.50	0.29	10.62	QP
2	0.42	38.81	-8.65	47.46	27.90	0.29	10.62	Average
3	0.52	44.33	-11.67	56.00	33.50	0.20	10.63	QP
4 *	0.52	39.33	-6.67	46.00	28.50	0.20	10.63	Average
5	3.44	41.78	-14.22	56.00	30.80	0.17	10.81	QP
6	3.44	33.78	-12.22	46.00	22.80	0.17	10.81	Average
7	3.92	43.81	-12.19	56.00	32.80	0.18	10.83	QP
8	3.92	36.11	-9.89	46.00	25.10	0.18	10.83	Average
9	4.48	45.23	-10.77	56.00	34.20	0.19	10.84	QP
10	4.48	38.53	-7.47	46.00	27.50	0.19	10.84	Average
11	4.90	44.55	-11.45	56.00	33.50	0.20	10.85	QP
12	4.90	39.25	-6.75	46.00	28.20	0.20	10.85	Average
13	19.84	45.09	-14.91	60.00	33.90	0.10	11.09	QP
14	19.84	36.09	-13.91	50.00	24.90	0.10	11.09	Average
15	21.26	44.10	-15.90	60.00	32.90	0.10	11.10	QP
16	21.26	35.40	-14.60	50.00	24.20	0.10	11.10	Average
17	24.66	42.13	-17.87	60.00	30.90	0.10	11.13	QP
18	24.66	33.13	-16.87	50.00	21.90	0.10	11.13	Average



Test Mode :	Mode 1	Temperature :	22~24°C
Test Engineer :	Eko Guan	Relative Humidity :	37~39%
Test Voltage :	120Vac / 60Hz	Phase :	Neutral
Function Type :	GSM850 Idle + Bluetooth Link + WLAN Link + Earphone + USB Cable 1 (Charging from Adapter)		

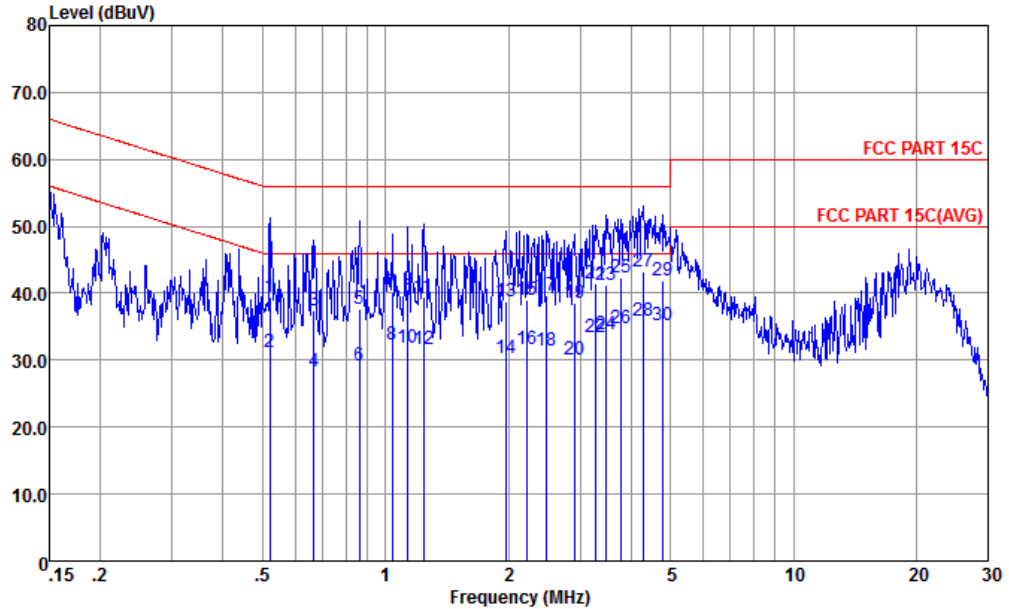

Site : CO01-KS  
 Condition : FCC PART 15C LISN-N20140306 NEUTRAL

mode : Mode 1

	Freq	Level	Over Limit	Limit Line	Read Level	LISN Factor	Cable Loss	Remark
	MHz	dBuV	dB	dBuV	dBuV	dB	dB	
1	0.52	39.52	-16.48	56.00	28.60	0.29	10.63	QP
2	0.52	31.12	-14.88	46.00	20.20	0.29	10.63	Average
3	0.67	37.35	-18.65	56.00	26.50	0.21	10.64	QP
4	0.67	28.35	-17.65	46.00	17.50	0.21	10.64	Average
5	0.86	37.58	-18.42	56.00	26.79	0.14	10.65	QP
6	0.86	29.28	-16.72	46.00	18.49	0.14	10.65	Average
7	1.04	40.05	-15.95	56.00	29.30	0.10	10.65	QP
8	1.04	32.25	-13.75	46.00	21.50	0.10	10.65	Average
9	1.14	40.66	-15.34	56.00	29.90	0.10	10.66	QP
10	1.14	31.86	-14.14	46.00	21.10	0.10	10.66	Average
11	1.24	39.36	-16.64	56.00	28.60	0.10	10.66	QP
12	1.24	31.56	-14.44	46.00	20.80	0.10	10.66	Average
13	1.97	38.70	-17.30	56.00	27.90	0.10	10.70	QP
14	1.97	30.40	-15.60	46.00	19.60	0.10	10.70	Average
15	2.22	38.92	-17.08	56.00	28.10	0.11	10.71	QP
16	2.22	31.62	-14.38	46.00	20.80	0.11	10.71	Average
17	2.47	39.64	-16.36	56.00	28.80	0.11	10.73	QP
18	2.47	31.34	-14.66	46.00	20.50	0.11	10.73	Average
19	2.90	38.51	-17.49	56.00	27.61	0.13	10.77	QP
20	2.90	30.11	-15.89	46.00	19.21	0.13	10.77	Average
21	3.28	41.46	-14.54	56.00	30.50	0.16	10.80	QP
22	3.28	33.46	-12.54	46.00	22.50	0.16	10.80	Average
23	3.47	41.18	-14.82	56.00	30.20	0.17	10.81	QP
24	3.47	33.88	-12.12	46.00	22.90	0.17	10.81	Average
25	3.78	42.30	-13.70	56.00	31.30	0.18	10.82	QP



Test Mode :	Mode 1	Temperature :	22~24°C
Test Engineer :	Eko Guan	Relative Humidity :	37~39%
Test Voltage :	120Vac / 60Hz	Phase :	Neutral
Function Type :	GSM850 Idle + Bluetooth Link + WLAN Link + Earphone + USB Cable 1 (Charging from Adapter)		

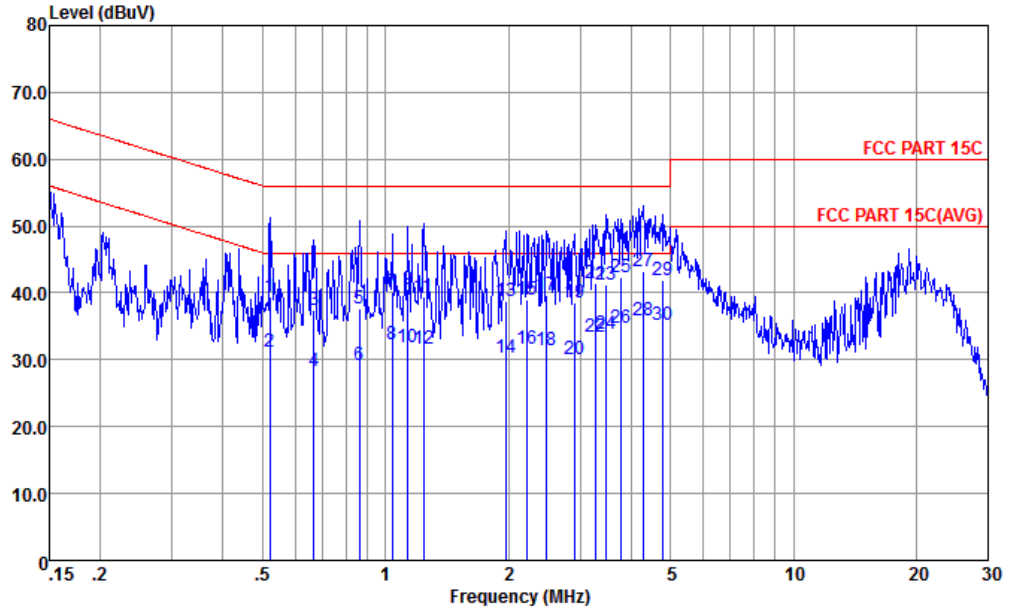

Site : CO01-KS  
 Condition : FCC PART 15C LISN-N20140306 NEUTRAL  
 mode : Mode 1

	Freq	Level	Over Limit	Limit Line	Read Level	LISN Factor	Cable Loss	Remark
	MHz	dBuV	dB	dBuV	dBuV	dB	dB	
26	3.78	34.80	-11.20	46.00	23.80	0.18	10.82	Average
27	4.27	43.32	-12.68	56.00	32.30	0.19	10.83	QP
28 *	4.27	35.82	-10.18	46.00	24.80	0.19	10.83	Average
29	4.77	41.84	-14.16	56.00	30.80	0.20	10.84	QP
30	4.77	35.24	-10.76	46.00	24.20	0.20	10.84	Average



## **3.7 Antenna Requirements**

### **3.7.1 Standard Applicable**

If directional gain of transmitting antennas is greater than 6dBi, the power shall be reduced by the same level in dB comparing to gain minus 6dBi. For the fixed point-to-point operation, the power shall be reduced by one dB for every 3 dB that the directional gain of the antenna exceeds 6 dBi. The use of a permanently attached antenna or of an antenna that uses a unique coupling to the intentional radiator shall be considered sufficient to comply with the FCC rule.

### **3.7.2 Antenna Anti-Replacement Construction**

An embedded-in antenna design is used.

### **3.7.3 Antenna Gain**

The antenna peak gain of EUT is less than 6 dBi. Therefore, it is not necessary to reduce maximum peak output power limit.



## 4 List of Measuring Equipment

Instrument	Manufacturer	Model No.	Serial No.	Characteristics	Calibration Date	Test Date	Due Date	Remark
Spectrum Analyzer	R&S	FSV30	101338	9kHz~30GHz	May 04, 2015	Jun. 17, 2015~ Jul. 04, 2015	May 03, 2016	Conducted (TH01-KS)
Pulse Power Sensor	Anritsu	MA2411B	0917070	30MHz~40GHz	Jan. 23, 2015	Jun. 17, 2015~ Jul. 04, 2015	Jan. 22, 2016	Conducted (TH01-KS)
Power Meter	Anritsu	ML2495A	1005002	50MHz Bandwidth	Jan. 23, 2015	Jun. 17, 2015~ Jul. 04, 2015	Jan. 22, 2016	Conducted (TH01-KS)
EMI Test Receiver	R&S	ESR7	101403	9kHz~7GHz;Ma x 30dBm	Sep. 29, 2014	Jul. 02, 2015	Sep. 28, 2015	Radiation (03CH02-KS)
Spectrum Analyzer	R&S	FSV40	101040	10kHz~40GHz; Max 30dBm	Sep. 25, 2014	Jul. 02, 2015	Sep. 24, 2015	Radiation (03CH02-KS)
Loop Antenna	R&S	HFH2-Z2	100321	9kHz~30MHz	Nov. 13, 2014	Jul. 02, 2015	Nov. 12, 2015	Radiation (03CH02-KS)
Bilog Antenna	TeseQ	CBL6112D	37879	30MHz~2GHz	Sep. 13, 2014	Jul. 02, 2015	Sep. 12, 2015	Radiation (03CH02-KS)
Double Ridge Horn Antenna	ETS-Lindgren	3117	75957	1GHz~18GHz	Nov. 08, 2014	Jul. 02, 2015	Nov. 07, 2015	Radiation (03CH02-KS)
Active Horn Antenna	com-power	AHA-118	701030	1GHz~18GHz	Nov. 08, 2014	Jul. 02, 2015	Nov. 07, 2015	Radiation (03CH02-KS)
SHF-EHF Horn	com-power	AH-840	101070	18Ghz~40GHz	Sep. 04, 2014	Jul. 02, 2015	Sep. 03, 2015	Radiation (03CH02-KS)
Amplifier	com-power	PA-103A	161069	1kHz~1000MHz / 32 dB	May 04, 2015	Jul. 02, 2015	May 03, 2016	Radiation (03CH02-KS)
Amplifier	Agilent	8449B	3008A023 84	1GHz~26.5GHz	Oct. 28, 2014	Jul. 02, 2015	Oct. 27, 2015	Radiation (03CH02-KS)
AC Power Source	Chroma	61601	616010002 473	N/A	NCR	Jul. 02, 2015	NCR	Radiation (03CH02-KS)
Turn Table	MF	MF7802	N/A	0~360 degree	NCR	Jul. 02, 2015	NCR	Radiation (03CH02-KS)
Antenna Mast	MF	MF7802	N/A	1 m~4 m	NCR	Jul. 02, 2015	NCR	Radiation (03CH02-KS)
EMI Receiver	R&S	ESCI7	100768	9kHz~7GHz	May 04, 2015	Jun. 19, 2015	May 03, 2016	Conduction (CO01-KS)
AC LISN	MessTec	AN3016	060103	9kHz~30MHz	Oct. 25, 2014	Jun. 19, 2015	Oct. 24, 2015	Conduction (CO01-KS)
AC LISN (for auxiliary equipment)	MessTec	AN3016	060105	9kHz~30MHz	Oct. 25, 2014	Jun. 19, 2015	Oct. 24, 2015	Conduction (CO01-KS)
AC Power Source	Chroma	61602	ABP00000 0811	AC 0V~300V, 45Hz~1000Hz	Oct. 25, 2014	Jun. 19, 2015	Oct. 24, 2015	Conduction (CO01-KS)





## 5 Uncertainty of Evaluation

### Uncertainty of Conducted Emission Measurement (150kHz ~ 30MHz)

Measuring Uncertainty for a Level of Confidence of 95% ( $U = 2Uc(y)$ )	2.3dB
---	-------

### Uncertainty of Radiated Emission Measurement (30 MHz ~ 1000 MHz)

Measuring Uncertainty for a Level of Confidence of 95% ( $U = 2Uc(y)$ )	5.1dB
---	-------



## **Appendix A. Conducted Test Results**

Test Engineer:	Issac Song	Temperature:	21~25	°C
Test Date:	2015/6/17~2015/7/4	Relative Humidity:	51~54	%

**TEST RESULTS DATA**  
**6dB and 99% Occupied Bandwidth**

2.4GHz Band								
Mod.	Data Rate	NTX	CH.	Freq. (MHz)	99% Occupied BW (MHz)	6dB BW (MHz)	6dB BW Limit (MHz)	Pass/Fail
11b	1Mbps	1	1	2412	11.94	7.55	0.50	Pass
11b	1Mbps	1	6	2437	11.79	7.09	0.50	Pass
11b	1Mbps	1	11	2462	11.84	7.55	0.50	Pass
11g	6Mbps	1	1	2412	18.43	15.94	0.50	Pass
11g	6Mbps	1	6	2437	18.23	16.34	0.50	Pass
11g	6Mbps	1	11	2462	18.18	16.34	0.50	Pass
HT20	MCS0	1	1	2412	18.88	16.68	0.50	Pass
HT20	MCS0	1	6	2437	19.08	17.58	0.50	Pass
HT20	MCS0	1	11	2462	18.98	17.58	0.50	Pass

**TEST RESULTS DATA**  
**Peak Power Table**

2.4GHz Band										
Mod.	Data Rate	Ntx	CH.	Freq. (MHz)	Peak Conducted Power (dBm)	Conducted Power Limit (dBm)	DG (dBi)	EIRP Power (dBm)	EIRP Power Limit (dBm)	Pass /Fail
11b	1Mbps	1	1	2412	18.68	30.00	-1.50	17.18	36.00	Pass
11b	1Mbps	1	6	2437	19.16	30.00	-1.50	17.66	36.00	Pass
11b	1Mbps	1	11	2462	18.57	30.00	-1.50	17.07	36.00	Pass
11g	6Mbps	1	1	2412	22.63	30.00	-1.50	21.13	36.00	Pass
11g	6Mbps	1	6	2437	23.39	30.00	-1.50	21.89	36.00	Pass
11g	6Mbps	1	11	2462	22.13	30.00	-1.50	20.63	36.00	Pass
HT20	MCS0	1	1	2412	22.93	30.00	-1.50	21.43	36.00	Pass
HT20	MCS0	1	6	2437	23.31	30.00	-1.50	21.81	36.00	Pass
HT20	MCS0	1	11	2462	22.20	30.00	-1.50	20.70	36.00	Pass

**TEST RESULTS DATA**  
**Average Power Table**  
**(Reporting Only)**

2.4GHz Band						
Mod.	Data Rate	NTX	CH.	Freq. (MHz)	Duty Factor (dB)	Average Conducted Power (dBm)
11b	1Mbps	1	1	2412	0.10	14.96
11b	1Mbps	1	6	2437	0.10	15.69
11b	1Mbps	1	11	2462	0.10	15.07
11g	6Mbps	1	1	2412	0.59	13.46
11g	6Mbps	1	6	2437	0.59	13.84
11g	6Mbps	1	11	2462	0.59	13.56
HT20	MCS0	1	1	2412	0.63	13.49
HT20	MCS0	1	6	2437	0.63	13.80
HT20	MCS0	1	11	2462	0.63	13.54

**TEST RESULTS DATA**  
**Peak Power Density**

2.4GHz Band								
Mod.	Data Rate	NTX	CH.	Freq. (MHz)	Peak PSD (dBm /3kHz)	DG (dBi)	Peak PSD Limit (dBm /3kHz)	Pass/Fail
11b	1Mbps	1	1	2412	-4.68	-1.50	8.00	Pass
11b	1Mbps	1	6	2437	-4.47	-1.50	8.00	Pass
11b	1Mbps	1	11	2462	-5.56	-1.50	8.00	Pass
11g	6Mbps	1	1	2412	-8.67	-1.50	8.00	Pass
11g	6Mbps	1	6	2437	-8.30	-1.50	8.00	Pass
11g	6Mbps	1	11	2462	-10.04	-1.50	8.00	Pass
HT20	MCS0	1	1	2412	-9.49	-1.50	8.00	Pass
HT20	MCS0	1	6	2437	-9.31	-1.50	8.00	Pass
HT20	MCS0	1	11	2462	-10.16	-1.50	8.00	Pass



## Appendix B. Radiated Spurious Emission

2.4GHz 2400~2483.5MHz

WIFI 802.11b (Band Edge @ 3m)

WIFI	Note	Frequency	Level	Over	Limit	Read	Antenna	Cable	Preamp	Ant	Table	Peak	Pol.
Ant.				Limit	Line	Level	Factor	Loss	Factor	Pos	Pos	Avg.	
1		( MHz )	( dBμV/m )	( dB )	( dBμV/m )	( dBμV )	( dB/m )	( dB )	( dB )	( cm )	( deg )	(P/A)	(H/V)
802.11b CH 01 2412MHz		2374.89	52.99	-21.01	74	46.92	31.28	6.17	31.38	202	193	P	H
		2342.67	39.28	-14.72	54	33.34	31.25	6.12	31.43	202	193	A	H
	*	2413.026	103.68	-	-	97.44	31.31	6.22	31.29	202	193	P	H
	*	2412.692	99.37	-	-	93.13	31.31	6.22	31.29	202	193	A	H
		2329.17	52.7	-21.3	74	46.8	31.23	6.12	31.45	153	268	P	V
		2317.56	39.05	-14.95	54	33.21	31.23	6.06	31.45	153	268	A	V
	*	2413.11	104.37	-	-	98.13	31.31	6.22	31.29	153	268	P	V
	*	2411.189	100.09	-	-	93.85	31.31	6.22	31.29	153	268	A	V
802.11b CH 06 2437MHz	*	2435.989	102.28	-	-	95.95	31.33	6.22	31.22	298	193	P	H
	*	2436.239	98.07	-	-	91.74	31.33	6.22	31.22	298	193	A	H
	*	2435.822	104.22	-	-	97.89	31.33	6.22	31.22	176	228	P	V
	*	2436.239	100.05	-	-	93.72	31.33	6.22	31.22	176	228	A	V





<b>802.11b CH 11 2462MHz</b>	*	2463.126	101.03	-	-	94.48	31.36	6.28	31.09	181	61	P	H
	*	2462.792	96.71	-	-	90.16	31.36	6.28	31.09	181	61	A	H
		2498.24	52.78	-21.22	74	46.01	31.39	6.33	30.95	181	61	P	H
		2483.92	38.91	-15.09	54	32.23	31.37	6.33	31.02	181	61	A	H
	*	2463.126	106.58	-	-	100.03	31.36	6.28	31.09	235	95	P	V
	*	2462.792	102.35	-	-	95.8	31.36	6.28	31.09	235	95	A	V
		2486.76	52.64	-21.36	74	45.96	31.37	6.33	31.02	235	95	P	V
		2483.52	39.59	-14.41	54	32.91	31.37	6.33	31.02	235	95	A	V
<b>Remark</b>	1. No other spurious found. 2. All results are PASS against Peak and Average limit line.												



**2.4GHz 2400~2483.5MHz  
WIFI 802.11b (Harmonic @ 3m)**

WIFI Ant. 1	Note	Frequency ( MHz )	Level ( dBμV/m )	Over Limit ( dB )	Limit Line ( dBμV/m )	Read Level ( dBμV )	Antenna Factor ( dB/m )	Cable Loss ( dB )	Preamp Factor ( dB )	Ant Pos ( cm )	Table Pos ( deg )	Peak Avg. (P/A)	Pol. (H/V)
802.11b CH 01 2412MHz		4824	60.89	-13.11	74	49.85	34.89	8.73	32.58	154	65	P	H
	!	4824	50.95	-3.05	54	39.91	34.89	8.73	32.58	154	65	A	H
		4824	61.27	-12.73	74	50.23	34.89	8.73	32.58	212	0	P	V
	!	4824	50.89	-3.11	54	39.85	34.89	8.73	32.58	212	0	A	V
802.11b CH 06 2437MHz		4875	48.6	-25.4	74	37.74	34.92	8.76	32.82	158	268	P	H
		7311	47.66	-26.34	74	36.31	35.56	10.84	35.05	167	230	P	H
		4875	48.43	-25.57	74	37.57	34.92	8.76	32.82	184	210	P	V
		7311	47.36	-26.64	74	36.01	35.56	10.84	35.05	196	250	P	V
802.11b CH 11 2462MHz		4923	48.75	-25.25	74	38.07	34.95	8.79	33.06	166	302	P	H
		7386	46.85	-27.15	74	35.77	35.58	10.89	35.39	210	0	P	H
		4923	49.16	-24.84	74	38.48	34.95	8.79	33.06	188	230	P	V
		7386	47.59	-26.41	74	36.51	35.58	10.89	35.39	169	152	P	V
Remark	1. No other spurious found. 2. All results are PASS against Peak and Average limit line.												



2.4GHz 2400~2483.5MHz
WIFI 802.11g (Band Edge @ 3m)

Table with 14 columns: WIFI Ant. 1, Note, Frequency (MHz), Level (dBµV/m), Over Limit (dB), Limit Line (dBµV/m), Read Level (dBµV), Antenna Factor (dB/m), Cable Loss (dB), Preamp Factor (dB), Ant Pos (cm), Table Pos (deg), Peak Avg. (P/A), Pol. (H/V). Rows include data for 802.11g CH 01 (2412MHz) and 802.11g CH 06 (2437MHz).



<b>802.11g CH 11 2462MHz</b>	*	2466.8	102.06	-	-	95.51	31.36	6.28	31.09	272	193	P	H
	*	2460.204	90.35	-	-	83.8	31.36	6.28	31.09	272	193	A	H
		2483.56	62.05	-11.95	74	55.37	31.37	6.33	31.02	272	193	P	H
		2483.88	39.75	-14.25	54	33.07	31.37	6.33	31.02	272	193	A	H
	*	2468.887	104.08	-	-	97.53	31.36	6.28	31.09	150	266	P	V
	*	2469.138	93.24	-	-	86.69	31.36	6.28	31.09	150	266	A	V
		2483.84	65.35	-8.65	74	58.67	31.37	6.33	31.02	150	266	P	V
		2483.6	42.55	-11.45	54	35.87	31.37	6.33	31.02	150	266	A	V
<b>Remark</b>	1. No other spurious found. 2. All results are PASS against Peak and Average limit line.												



**2.4GHz 2400~2483.5MHz  
WIFI 802.11g (Harmonic @ 3m)**

WIFI Ant. 1	Note	Frequency ( MHz )	Level ( dBμV/m )	Over Limit ( dB )	Limit Line ( dBμV/m )	Read Level ( dBμV )	Antenna Factor ( dB/m )	Cable Loss ( dB )	Preamp Factor ( dB )	Ant Pos ( cm )	Table Pos ( deg )	Peak Avg. (P/A)	Pol. (H/V)
802.11g CH 01 2412MHz		4824	48.19	-25.81	74	37.15	34.89	8.73	32.58	162	120	P	H
		4824	58.47	-15.53	74	47.43	34.89	8.73	32.58	166	0	P	V
		4824	44.89	-9.11	54	33.85	34.89	8.73	32.58	166	0	A	V
802.11g CH 06 2437MHz		4875	47.2	-26.8	74	36.34	34.92	8.76	32.82	188	236	P	H
		7311	47.48	-26.52	74	36.13	35.56	10.84	35.05	184	203	P	H
		4875	47.9	-26.1	74	37.04	34.92	8.76	32.82	169	263	P	V
		7311	48.46	-25.54	74	37.11	35.56	10.84	35.05	216	110	P	V
802.11g CH 11 2462MHz		4923	46.28	-27.72	74	35.6	34.95	8.79	33.06	174	130	P	H
		7386	48.89	-25.11	74	37.81	35.58	10.89	35.39	175	210	P	H
		4923	47.17	-26.83	74	36.49	34.95	8.79	33.06	185	213	P	V
		7386	46.62	-27.38	74	35.54	35.58	10.89	35.39	196	230	P	V
Remark	1. No other spurious found. 2. All results are PASS against Peak and Average limit line.												



**2.4GHz 2400~2483.5MHz  
WIFI 802.11n HT20 (Band Edge @ 3m)**

WIFI Ant. 1	Note	Frequency ( MHz )	Level ( dBμV/m )	Over Limit ( dB )	Limit Line ( dBμV/m )	Read Level ( dBμV )	Antenna Factor ( dB/m )	Cable Loss ( dB )	Preamp Factor ( dB )	Ant Pos ( cm )	Table Pos ( deg )	Peak Avg. ( P/A )	Pol. ( H/V )
802.11n HT20 CH 01 2412MHz		2389.92	53.54	-20.46	74	47.43	31.3	6.17	31.36	190	207	P	H
		2390	39.77	-14.23	54	33.66	31.3	6.17	31.36	190	207	A	H
	*	2416.783	104.35	-	-	98.11	31.31	6.22	31.29	190	207	P	H
	*	2416.366	92.79	-	-	86.55	31.31	6.22	31.29	190	207	A	H
		2389.74	53.59	-20.41	74	47.48	31.3	6.17	31.36	150	135	P	V
		2390	39.86	-14.14	54	33.75	31.3	6.17	31.36	150	135	A	V
	*	2416.449	106.1	-	-	99.86	31.31	6.22	31.29	150	135	P	V
	*	2416.366	94.88	-	-	88.64	31.31	6.22	31.29	150	135	A	V
802.11n HT20 CH 06 2437MHz	*	2444.422	99.02	-	-	92.56	31.34	6.28	31.16	251	148	P	H
	*	2444.84	88.4	-	-	81.94	31.34	6.28	31.16	251	148	A	H
	*	2430.979	103.36	-	-	97.03	31.33	6.22	31.22	257	111	P	V
	*	2444.506	91.76	-	-	85.3	31.34	6.28	31.16	257	111	A	V



<b>802.11n</b> <b>HT20</b> <b>CH 11</b> <b>2462MHz</b>	*	2465.631	104.54	-	-	97.99	31.36	6.28	31.09	192	148	P	H
	*	2468.887	93.69	-	-	87.14	31.36	6.28	31.09	192	148	A	H
		2483.6	66.48	-7.52	74	59.8	31.37	6.33	31.02	192	148	P	H
		2483.68	42.5	-11.5	54	35.82	31.37	6.33	31.02	192	148	A	H
	*	2466.466	105.92	-	-	99.37	31.36	6.28	31.09	167	128	P	V
	*	2469.388	94.87	-	-	88.32	31.36	6.28	31.09	167	128	A	V
	!	2484.28	68.19	-5.81	74	61.51	31.37	6.33	31.02	167	128	P	V
	2483.52	44.16	-9.84	54	37.48	31.37	6.33	31.02	167	128	A	V	
<b>Remark</b>	1. No other spurious found. 2. All results are PASS against Peak and Average limit line.												



**2.4GHz 2400~2483.5MHz  
WIFI 802.11n HT20 (Harmonic @ 3m)**

WIFI Ant. 1	Note	Frequency ( MHz )	Level ( dBμV/m )	Over Limit ( dB )	Limit Line ( dBμV/m )	Read Level ( dBμV )	Antenna Factor ( dB/m )	Cable Loss ( dB )	Preamp Factor ( dB )	Ant Pos ( cm )	Table Pos ( deg )	Peak Avg. (P/A)	Pol. (H/V)
802.11n HT20 CH 01 2412MHz		4824	46.28	-27.72	74	35.24	34.89	8.73	32.58	163	29	P	H
		4824	45.35	-28.65	74	34.31	34.89	8.73	32.58	154	223	P	V
802.11n HT20 CH 06 2437MHz		4875	46.53	-27.47	74	35.67	34.92	8.76	32.82	169	230	P	H
		7311	47.29	-26.71	74	35.94	35.56	10.84	35.05	188	264	P	H
		4875	46.57	-27.43	74	35.71	34.92	8.76	32.82	198	203	P	V
		7311	47.8	-26.2	74	36.45	35.56	10.84	35.05	203	102	P	V
802.11n HT20 CH 11 2462MHz		4923	45.56	-28.44	74	34.88	34.95	8.79	33.06	164	57	P	H
		7386	48.2	-25.8	74	37.12	35.58	10.89	35.39	174	261	P	H
		4923	45.37	-28.63	74	34.69	34.95	8.79	33.06	195	230	P	V
		7386	48.31	-25.69	74	37.23	35.58	10.89	35.39	156	24	P	V
Remark	1. No other spurious found. 2. All results are PASS against Peak and Average limit line.												





Emission below 1GHz  
2.4GHz WIFI 802.11b (LF)

WIFI	Note	Frequency	Level	Over	Limit	Read	Antenna	Cable	Preamp	Ant	Table	Peak	Pol.
Ant.				Limit	Line	Level	Factor	Loss	Factor	Pos	Pos	Avg.	
1		( MHz )	( dBμV/m )	( dB )	( dBμV/m )	( dBμV )	( dB/m )	( dB )	( dB )	( cm )	( deg )	( P/A )	( H/V )
2.4GHz 802.11b LF		30	25.56	-14.44	40	38.23	19.2	0.79	32.66			P	H
		35.82	25.11	-14.89	40	40.68	16.26	0.79	32.62			P	H
		87.23	29.51	-10.49	40	51.23	9.87	1.04	32.63	105	47	P	H
		95.96	29.78	-13.72	43.5	50.48	10.86	1.04	32.6			P	H
		141.55	26.26	-17.24	43.5	45.96	11.63	1.23	32.56			P	H
		209.45	28.68	-14.82	43.5	49.31	10.24	1.61	32.48			P	H
	!	35.82	36.27	-3.73	40	51.84	16.26	0.79	32.62	124	56	P	V
	!	55.22	35.02	-4.98	40	59.43	7.4	0.79	32.6			P	V
		61.04	32.96	-7.04	40	58.46	6.31	0.79	32.6			P	V
	!	87.23	34.2	-5.8	40	55.92	9.87	1.04	32.63			P	V
		159.98	27.46	-16.04	43.5	47.24	11.33	1.44	32.55			P	V
		224.97	24.65	-21.35	46	44.58	10.95	1.61	32.49			P	V
Remark	1. No other spurious found. 2. All results are PASS against limit line.												



Emission below 1GHz  
2.4GHz WIFI 802.11g (LF)

WIFI	Note	Frequency	Level	Over	Limit	Read	Antenna	Cable	Preamp	Ant	Table	Peak	Pol.
Ant.				Limit	Line	Level	Factor	Loss	Factor	Pos	Pos	Avg.	
1		( MHz )	( dBμV/m )	( dB )	( dBμV/m )	( dBμV )	( dB/m )	( dB )	( dB )	( cm )	( deg )	( P/A )	( H/V )
2.4GHz 802.11g LF		30	28.56	-11.44	40	41.23	19.2	0.79	32.66			P	H
		35.82	28.11	-11.89	40	43.68	16.26	0.79	32.62			P	H
		87.23	31.51	-8.49	40	53.23	9.87	1.04	32.63	106	86	P	H
		103.72	30.64	-12.86	43.5	50.91	11.33	1.04	32.64			P	H
		131.85	29.2	-14.3	43.5	49.01	11.55	1.23	32.59			P	H
		209.45	31.68	-11.82	43.5	52.31	10.24	1.61	32.48			P	H
	!	30	36.39	-3.61	40	49.06	19.2	0.79	32.66	116	261	P	V
	!	35.82	35.27	-4.73	40	50.84	16.26	0.79	32.62			P	V
	!	47.46	35.82	-4.18	40	57.44	10.23	0.79	32.64			P	V
	!	56.19	34.49	-5.51	40	59.16	7.14	0.79	32.6			P	V
		61.04	32.96	-7.04	40	58.46	6.31	0.79	32.6			P	V
		159.98	29.46	-14.04	43.5	49.24	11.33	1.44	32.55			P	V
Remark	1. No other spurious found. 2. All results are PASS against limit line.												



Emission below 1GHz

2.4GHz WIFI 802.11n HT20 (LF)

WIFI	Note	Frequency	Level	Over	Limit	Read	Antenna	Cable	Preamp	Ant	Table	Peak	Pol.
Ant.				Limit	Line	Level	Factor	Loss	Factor	Pos	Pos	Avg.	
1		( MHz )	( dBμV/m )	( dB )	( dBμV/m )	( dBμV )	( dB/m )	( dB )	( dB )	( cm )	( deg )	( P/A )	( H/V )
2.4GHz 802.11n HT20 LF		30	25.56	-14.44	40	38.23	19.2	0.79	32.66			P	H
		87.23	29.51	-10.49	40	51.23	9.87	1.04	32.63			P	H
		103.72	34.64	-8.86	43.5	54.91	11.33	1.04	32.64	132	284	P	H
		131.85	33.2	-10.3	43.5	53.01	11.55	1.23	32.59			P	H
		144.46	27.08	-16.42	43.5	46.76	11.65	1.23	32.56			P	H
		209.45	30.68	-12.82	43.5	51.31	10.24	1.61	32.48			P	H
	!	30.97	36.63	-3.37	40	49.79	18.71	0.79	32.66	155	263	P	V
	!	35.82	36.27	-3.73	40	51.84	16.26	0.79	32.62			P	V
	!	56.19	34.49	-5.51	40	59.16	7.14	0.79	32.6			P	V
	!	61.04	35.96	-4.04	40	61.46	6.31	0.79	32.6			P	V
		87.23	29.2	-10.8	40	50.92	9.87	1.04	32.63			P	V
		159.98	27.46	-16.04	43.5	47.24	11.33	1.44	32.55			P	V
Remark	1. No other spurious found. 2. All results are PASS against limit line.												



Note symbol

*	<b>Fundamental Frequency</b> which can be ignored. However, the level of any unwanted emissions shall not exceed the level of the fundamental frequency.
!	Test result is <b>over limit</b> line.
P/A	<b>Peak</b> or <b>Average</b>
H/V	<b>Horizontal</b> or <b>Vertical</b>



A calculation example for radiated spurious emission is shown as below:

WIFI	Note	Frequency	Level	Over	Limit	Read	Antenna	Cable	Preamp	Ant	Table	Peak	Pol.
Ant.				Limit	Line	Level	Factor	Loss	Factor	Pos	Pos	Avg.	
1		( MHz )	( dBμV/m )	( dB )	( dBμV/m )	( dBμV )	( dB/m )	( dB )	( dB )	( cm )	( deg )	( P/A )	( H/V )
802.11b		2390	55.45	-18.55	74	54.51	32.22	4.58	35.86	103	308	P	H
CH 01													
2412MHz		2390	43.54	-10.46	54	42.6	32.22	4.58	35.86	103	308	A	H

- Level(dBμV/m) =  
Antenna Factor(dB/m) + Cable Loss(dB) + Read Level(dBμV) - Preamp Factor(dB)
- Over Limit(dB) = Level(dBμV/m) – Limit Line(dBμV/m)

**For Peak Limit @ 2390MHz:**

- Level(dBμV/m)  
= Antenna Factor(dB/m) + Cable Loss(dB) + Read Level(dBμV) - Preamp Factor(dB)  
= 32.22(dB/m) + 4.58(dB) + 54.51(dBμV) – 35.86 (dB)  
= 55.45 (dBμV/m)
- Over Limit(dB)  
= Level(dBμV/m) – Limit Line(dBμV/m)  
= 55.45(dBμV/m) – 74(dBμV/m)  
= -18.55(dB)

**For Average Limit @ 2390MHz:**

- Level(dBμV/m)  
= Antenna Factor(dB/m) + Cable Loss(dB) + Read Level(dBμV) - Preamp Factor(dB)  
= 32.22(dB/m) + 4.58(dB) + 42.6(dBμV) – 35.86 (dB)  
= 43.54 (dBμV/m)
- Over Limit(dB)  
= Level(dBμV/m) – Limit Line(dBμV/m)  
= 43.54(dBμV/m) – 54(dBμV/m)  
= -10.46(dB)

Both peak and average measured complies with the limit line, so test result is “PASS”.



## **Appendix D. Photographs of EUT**

Please refer to Sporton report number EP533002 which is issued separately.