



849 NW STATE ROAD 45
NEWBERRY, FL 32669 USA
PH: 888.472.2424 OR 352.472.5500
FAX: 352.472.2030
EMAIL: INFO@TIMCOENGR.COM
[HTTP://WWW.TIMCOENGR.COM](http://WWW.TIMCOENGR.COM)

FCC PART 90 PAGING TRANSMITTER TEST REPORT

| | |
|-----------------------------|---|
| APPLICANT | SHENZHEN CONSTANT ELECTRONICS CO., LTD. |
| | F5, NO. 2 BLDG., EAST BRIGHT INDUSTRY REGION NO. 83 DABAO ROAD BAO'AN 33 DISTRICT SHENZHEN, GUANGDONG China |
| FCC ID | WH2-2611CA |
| MODEL NUMBER | 2611CA |
| PRODUCT DESCRIPTION | PAGING TRANSCEIVER |
| DATE SAMPLE RECEIVED | 10/6/2014 |
| DATE TESTED | 10/15/14 |
| TESTED BY | Sid Sanders |
| APPROVED BY | Cory Leverett |
| TIMCO REPORT NO. | 1805AUT14TestReport.docx |
| TEST RESULTS | <input checked="" type="checkbox"/> PASS <input type="checkbox"/> FAIL |

THE ATTACHED REPORT SHALL NOT BE REPRODUCED EXCEPT IN FULL
WITHOUT THE WRITTEN APPROVAL OF TIMCO ENGINEERING, INC.

TABLE OF CONTENTS

| | |
|--|----|
| GENERAL REMARKS | 2 |
| GENERAL INFORMATION..... | 3 |
| RF EXPOSURE INFORMATION: 47CFR 2.1093..... | 4 |
| TEST PROCEDURE..... | 4 |
| RF POWER OUTPUT..... | 5 |
| MODULATION CHARACTERISTICS | 6 |
| MODULATION CHARACTERISTICS | 6 |
| OCCUPIED BANDWIDTH | 7 |
| OCCUPIED BANDWIDTH DIGITAL..... | 9 |
| Part 90.210(D) Emission Mask D - 25.0 Khz Channel Digital..... | 9 |
| SPURIOUS EMISSIONS AT ANTENNA TERMINALS (CONDUCTED)..... | 10 |
| FIELD STRENGTH OF SPURIOUS RADIATION EMISSIONS | 11 |
| FREQUENCY STABILITY..... | 13 |
| TRANSIENT FREQUENCY BEHAVIOR | 14 |
| EQUIPMENT LIST | 17 |

GENERAL REMARKS

The attached report shall not be reproduced except in full without the written permission of Timco Engineering Inc.

Summary

The device under test does:

- fulfill the general approval requirements as identified in this test report
- not fulfill the general approval requirements as identified in this test report

Attestations

This equipment has been tested in accordance with the standards identified in this test report. To the best of my knowledge and belief, these tests were performed using the measurement procedures described in this report.

All instrumentation and accessories used to test products for compliance to the indicated standards are calibrated regularly in accordance with ISO 17025 requirements.

I attest that the necessary measurements were made, under my supervision, at:

Timco Engineering Inc.
849 NW State Road 45
Newberry, FL 32669

Authorized Signatory Name:



Project Manager/Testing Technician

Date: 11/14/2014

[Table of Contents](#)

GENERAL INFORMATION

EUT Specification

| | |
|--------------------------------|---|
| EUT Description | PAGING TRANSCEIVER |
| FCC ID | WH2-2611CA |
| Model Number | 2611CA |
| Operating Frequency | 462.750, - 465.000MHz (462.745, 462.775, 462.800, 462.825, 462.850, 462.875, 462.900, 462.925, 465.000 MHz) |
| Test Frequencies | 462.825MHz |
| Type of Emission | 14k0F1D |
| Modulation | FSK |
| EUT Power Source | <input checked="" type="checkbox"/> 110–120Vac/50– 60Hz |
| | <input type="checkbox"/> DC Power 12V |
| | <input type="checkbox"/> Battery Operated Exclusively |
| Test Item | <input type="checkbox"/> Prototype |
| | <input checked="" type="checkbox"/> Pre-Production |
| | <input type="checkbox"/> Production |
| Type of Equipment | <input checked="" type="checkbox"/> Fixed |
| | <input type="checkbox"/> Mobile |
| | <input type="checkbox"/> Portable |
| Test Conditions | The temperature was 24-26°C with a relative humidity of 50-65%. |
| Modification to the EUT | None |
| Test Exercise | The EUT was placed in continuous transmit mode. |
| Applicable Standards | ANSI/TIA 603-C:2004, FCC CFR 47 Part 90 |
| Test Facility | Timco Engineering Inc. at 849 NW State Road 45 Newberry, FL 32669 USA. |

[Table of Contents](#)



RF EXPOSURE INFORMATION: 47CFR 2.1093

This device is exempt from SAR.

TEST PROCEDURE

Power Line Conducted Interference: The procedure used was ANSI/TIA 603-C: 2004, using a 50uH LISN. Both lines were observed with the EUT transmitting. The bandwidth of the spectrum analyzer was 10 kHz with an appropriate sweep speed.

Bandwidth 20 dB: The measurements were made with the spectrum analyzer's resolution bandwidth (RBW) = 1 MHz and the video bandwidth (VBW) = 3 MHz and the span set as shown on plot.

Power Output: The RF power output was measured at the antenna feed point using a peak power meter.

Antenna Conducted Emissions: The RBW = 100 kHz, VBW = 300 kHz and the span set to 10.0 MHz and the spectrum was scanned from 30 MHz to the 10th harmonic of the fundamental. Above 1 GHz the resolution bandwidth was 1 MHz and the VBW = 3 MHz and the span to 50 MHz.

Radiation Interference: The test procedure used was ANSI/TIA 603-C: 2004, using an Agilent spectrum receiver with pre-selector. The bandwidth (RBW) of the spectrum ANSI/TIA 603-C: 2004, receiver was 100 kHz up to 1 GHz and 1 MHz above 1 GHz with an appropriate sweep speed. The VBW above 1 GHz was 3 MHz. The analyzer was calibrated in dB above a microvolt at the output of the antenna.

[Table of Contents](#)

Applicant: SHENZHEN CONSTANT ELECTRONICS CO., LTD.
FCC ID: WH2-2611CA
Report: S\SZ CONSTANT_WH2\1805AUT14\1805AUT14TestReport.docx

RF POWER OUTPUT

Rule Part No.: Part 2.1046(a), Part 90

Test Requirements:

Method of Measurement: RF power is measured by using a 50-ohm, resistive wattmeter to the RF output connector. With a nominal battery voltage (if battery operated), or a properly adjusted power supply (if not battery operated), and the transmitter properly adjusted the RF output measures:

For the device with a fixed or integral antenna, the RF power is measured as ERP. The substitution method was used. The RF output measures:

Test Setup Diagram:

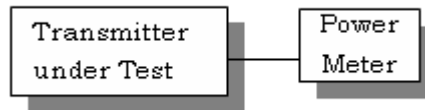

Test Data: 26.6dBm

| | RF Power |
|-----------------------|----------|
| Tuned Frequency (MHz) | Hi |
| 462.745 | 0.5 |

Part 2.1033 (C)(8) DC Input into the final amplifier

FOR POWER INPUT POWER: $(12.5V)(0.3A) = 3.75$ Watts

[Table of Contents](#)

MODULATION CHARACTERISTICS

Audio frequency response

Rule Part No.: Part 2.1047(a)(b)

Test Requirements:

Method of Measurement:

The audio frequency response was measured in accordance with TIA/EIA Specification 603 with no exception. A curve or equivalent data showing the frequency response of the audio modulating circuit over a range of 100 – 5000Hz shall be submitted. The audio frequency response curve is shown below.

Test Results: Not Applicable no Audio input.

AUDIO LOW PASS FILTER.

Rule Part 2.1047(a): For equipment required to have an audio low-pass filter, a curve showing the frequency response of the filter, or of all the circuitry installed between the modulation limiter and the modulated stage shall be submitted.

Test Results: Not Applicable no Audio input.

AUDIO INPUT VERSUS MODULATION

Rule Part No.: Part 2.1047(b) & 90

Test Requirements:

Method of Measurement: Modulation cannot exceed 100%, The audio input level needed for a particular percentage of modulation was measured in accordance with ANSI/TIA 603-C: 2004. The audio input curves versus modulation are shown below. Curves are provided for audio input frequencies of 300, 1000, and 3000 Hz.

Test Results: Not Applicable no Audio input.

MODULATION CHARACTERISTICS

Part 2.1033(c)

Part 2.1033(c) (4) Type of Emission: 14k2F1D ,

FCC Part 90.209

FCC Part 90.207

[Table of Contents](#)

OCCUPIED BANDWIDTH

Part 2.1049(c) EMISSION BANDWIDTH: **Part 90.210(b) 25 kHz Channel Spacing**

Data in the plots show that on any frequency removed from the assigned frequency by more than 50%, but not more than 100%: At least 25dB. On any frequency removed from the assigned frequency by more than 100%, but not more than 250%: At least 35 dB. On any frequency removed from the assigned frequency by more than 250%, of the authorized bandwidth: At least $43 + 10\log(P)$ dB.

Part 90.210(c) 25 kHz Channel Spacing Not Equipped with a Low Pass Filter

For transmitters that are not equipped with an audio low pass filter pursuant to S90.211 (b), the power of any emission must be attenuated below the un-modulated carrier output power as follows; (1) On any frequency removed from the center of the authorized bandwidth by a displacement frequency (f_d in kHz) of more than 5 kHz but not more than 10 kHz: At least $83 \log(f_d/5)$ dB; (2) ON any frequency removed from the center of the authorized bandwidth by a displacement frequency (f_d in kHz) of more than 10 kHz, but not more than 250% of the authorized bandwidth: At least $29 \log(f_d^2/11)$ dB or 50 dB, whichever is the lesser attenuation; (3) On any frequency removed from the center of the authorized bandwidth by more than 250% of the authorized bandwidth: At least $43 + 10 \log(P_0)$ dB.

Part 90.210(d) Emission Mask D - 12.5 kHz channel BW equipment.

For transmitters designed to operate with a 12.5 kHz channel bandwidth, any emission must be attenuated below the power (P) of the highest emission contained within the authorized bandwidth as follows:

- (1) On any frequency from the center of the authorized bandwidth f_0 to 5.625 kHz removed from f_0 : Zero dB.
- (2) On any frequency from the center of the authorized bandwidth by a displacement frequency (f_d in kHz) of more than 5.625 kHz but no more than 12.5 kHz: At least $7.27(f_d - 2.88 \text{ kHz})$ dB.
- (3) On any frequency removed from the center of the authorized bandwidth by a displacement frequency (f_d in kHz) of more than 12.5 kHz: At least $50 + 10\log(P)$ dB or 70 dB, whichever is the lesser attenuation.

Part 90.210(e) Emission Mask E – 6.25 kHz channel BW equipment.

For transmitters designed to operate with a 6.25 kHz bandwidth, any emission must be attenuated below the power (P) of the highest emission contained within the authorized bandwidth as follows:

- (1) On any frequency from the center of the authorized bandwidth f_0 to 3.0 kHz removed from f_0 : Zero dB.
- (2) On any frequency from the center of the authorized bandwidth by a displacement frequency (f_d in kHz) of more than 3.0 kHz but no more than 4.6 kHz: At least $30 + 16.67(f_d - 3.0 \text{ kHz})$ or $55 + 10 \log(P)$ or 65, whichever is the lesser attenuation.
- (3) On any frequency removed from the center of the authorized bandwidth by more than 4.6kHz: At least $55 + 10\log(P)$ dB or 65 dB, whichever is the lesser attenuation.

OCCUPIED BANDWIDTH

Method of Measurement: ANSI/TIA 603-C: 2004

Test Setup Diagram:

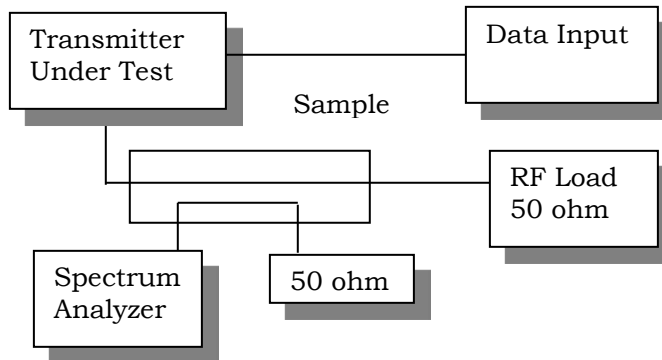

Requirement: 90.203(j)(7) Transmitters designed only for one-way paging operations may be certificated with up to a 25 kHz bandwidth and are exempt from the spectrum efficiency requirements of paragraphs (j)(3) and (j)(5) of this section.

Test Data: See the plots below

OCCUPIED BANDWIDTH DIGITAL

Part 90.210(D) Emission Mask D - 25.0 Khz Channel Digital

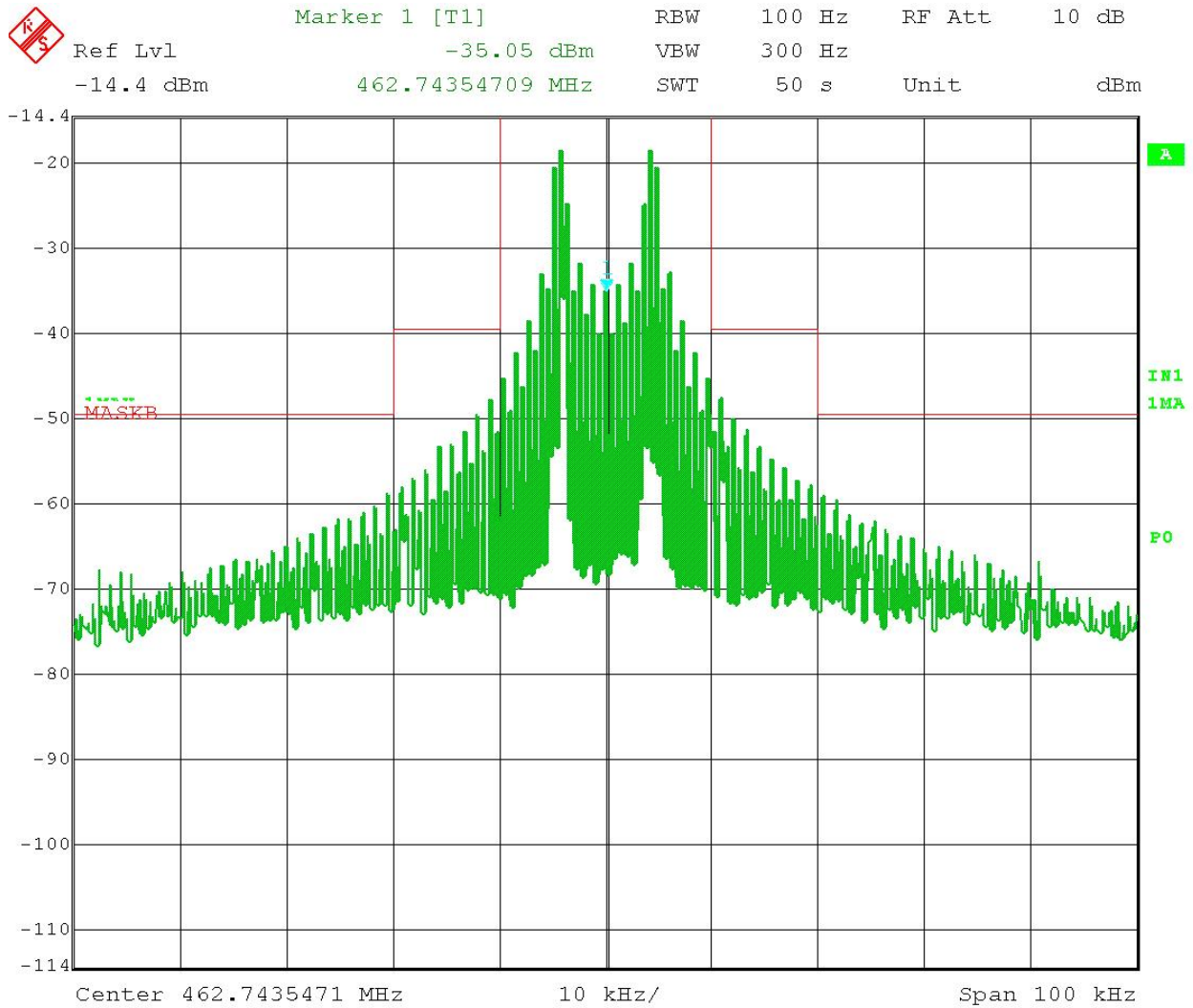

Date: 10.NOV.2014 17:14:35

Figure 2: Occupied bandwidth –

[Table of Contents](#)

SPURIOUS EMISSIONS AT ANTENNA TERMINALS (CONDUCTED)

Rule Part No.: Part 2.1051(a)

Method of Measuring Conducted Spurious Emissions

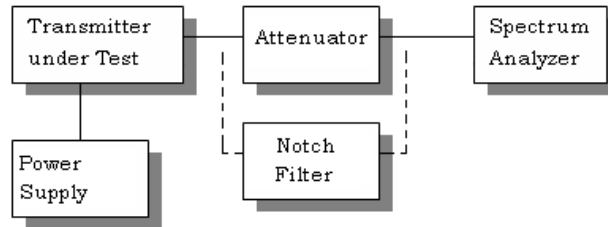

Requirements:

25.0kHz Channel Spacing = $43 + 10\log(P_o) = 40.00\text{dBc}$
 25.0kHz Channel Spacing = $43 + 10\log(0.50) = 40.00\text{dBc}$

Method of Measurement: The carrier was modulated 100% using a Digital signal. The spectrum was scanned from 0.4 to at least the 10th harmonic of the fundamental. The measurements were made in accordance with standard ANSI/TIA 603-C: 2004.

SPURIOUS EMISSIONS AT ANTENNA TERMINALS (CONDUCTED)

Test Data: 462.750-465.00 MHz

| | dBm | Watts |
|--------------|-----------|-------|
| Power Output | 25.9 | 0.5 |
| | | |
| | Frequency | dBc |
| | 462.745 | 0 |
| | 925.49 | 47.4 |
| | 1388.235 | 45.44 |
| | 1850.98 | 43.1 |
| | 2313.725 | 44.16 |
| | 2776.47 | 44.69 |
| | 3239.215 | 43.51 |
| | 3701.96 | 44.2 |
| | 4164.705 | 44.54 |
| | 4627.45 | 45.66 |
| | | |

Results: Meets Requirements.

[Table of Contents](#)

Applicant: SHENZHEN CONSTANT ELECTRONICS CO., LTD.

FCC ID: WH2-2611CA

Report: S\SZ CONSTANT_WH2\1805AUT14\1805AUT14TestReport.docx

FIELD STRENGTH OF SPURIOUS RADIATION EMISSIONS

Rule Parts. No.: Part 2.1053

Requirements:

$$25.0\text{kHz Channel Spacing} = 43 + 10\log(0.50) = 40.00\text{dBc}$$

METHOD OF MEASUREMENT: The tabulated data shows the results of the radiated field strength emissions test. The spectrum was scanned from 30 MHz to at least the tenth harmonic of the fundamental. This test was conducted per ANSI/TIA 603-C: 2004 using the substitution method. Measurements were made at the test site of TIMCO ENGINEERING, INC. located at 849 NW State Road 45, Newberry, FL 32669.

Test Setup Diagram:

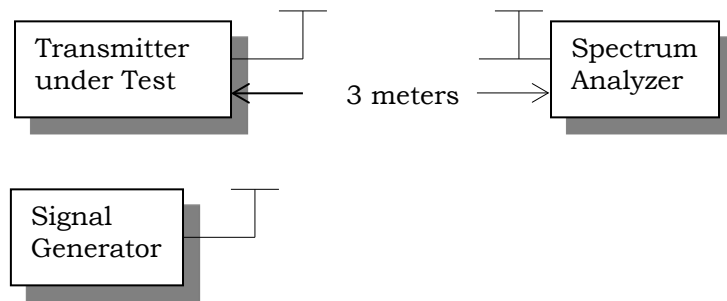

[Table of Contents](#)



FIELD STRENGTH OF SPURIOUS RADIATION EMISSIONS

Rule Parts. No.: Part 2.1053

Test Data: 462.750 – 465.000 MHz

| Emission Frequency (MHz) | Power Mode | ERP Power Output (dBm) | ERP Power Output (Watts) | FCC Requirement dB | Bandwidth - BW - kHz |
|--------------------------|------------|------------------------|--------------------------|--------------------|----------------------|
| 462.72 | Hi | 27.25 | 0.53 | 40.25 | 25.00 |

| Emission Frequency (MHz) | Ant. Polarity | Below Carrier (dBc) | Margin |
|--------------------------|---------------|---------------------|--------|
| 925.45 | V | 69.10 | 28.85 |
| 1,388.17 | V | 64.55 | 24.30 |
| 1,850.90 | H | 76.05 | 35.80 |
| 2,313.62 | H | 73.93 | 33.68 |
| 2,776.35 | H | 71.39 | 31.14 |
| 3,239.07 | H | 70.14 | 29.89 |
| 3,701.79 | H | 64.75 | 24.50 |
| 4,164.52 | H | 59.59 | 19.34 |
| 4,627.24 | H | 80.08 | 39.83 |

Results: Meets Requirements.

[Table of Contents](#)

FREQUENCY STABILITY

Rule Parts. No.: Part 2.1055, Part 90.213

Requirements: Temperature range requirements: -30 to +50° C.
Voltage Variation +, -15%
±2.5 PPM

Method of Measurements: ANSI/TIA 603-C: 2004.

Test Data: 462.750- 465.000 MHz Band

| Temperature | Frequency MHz | PPM |
|------------------|------------------|--------|
| 25°C (reference) | 462.74221 | |
| -30°C | 462.74292 | 1.534 |
| -20°C | 462.74246 | 0.540 |
| -10°C | 462.74154 | -1.448 |
| 0°C | 462.74174 | -1.016 |
| 10°C | 462.74112 | -2.356 |
| 20°C | 462.74294 | 1.578 |
| 30°C | 462.74309 | 1.902 |
| 40°C | 462.743307 | 2.371 |
| 50°C | 462.74304 | 1.794 |
| | | |
| Battery Voltage | Frequency | PPM |
| -15% | 462.74215 | -0.130 |
| 15% | 462.7423515 | 0.306 |

Results: Meets Requirements.

[Table of Contents](#)



TRANSIENT FREQUENCY BEHAVIOR

Part 90.214 Transient Frequency Behavior

REQUIREMENTS: Transmitters designed to operate in the 150-174 MHz and 421-512 MHz frequency bands must maintain transient frequencies within the maximum transient frequencies within the maximum frequency difference limits during the time intervals indicated:

| Time Intervals | Maximum frequency difference | All Equipment | |
|----------------|------------------------------|---------------|-------------|
| | | 150-174 MHz | 421-512 MHz |

Transient Frequency Behavior for Equipment Designed to Operate on 25 kHz Channels

| | | | |
|---------|----------------|---------|---------|
| t_1^4 | ± 25.0 kHz | 5.0 ms | 10.0 ms |
| t_2 | ± 12.5 kHz | 20.0 ms | 25.0 ms |
| t_3^4 | ± 25.0 kHz | 5.0 ms | 10.0 ms |

Transient Frequency Behavior for Equipment Designed to Operate on 12.5 kHz Channels

| | | | |
|---------|----------------|---------|---------|
| t_1^4 | ± 12.5 kHz | 5.0 ms | 10.0 ms |
| t_2 | ± 6.25 kHz | 20.0 ms | 25.0 ms |
| t_3^4 | ± 12.5 kHz | 5.0 ms | 10.0 ms |

Transient Frequency Behavior for Equipment Designed to Operate on 6.25 kHz Channels

| | | | |
|---------|-----------------|---------|---------|
| t_1^4 | ± 6.25 kHz | 5.0 ms | 10.0 ms |
| t_2 | ± 3.125 kHz | 20.0 ms | 25.0 ms |
| t_3^4 | ± 6.25 kHz | 5.0 ms | 10.0 ms |

Test Data:

Reading Floppy Disk Drive

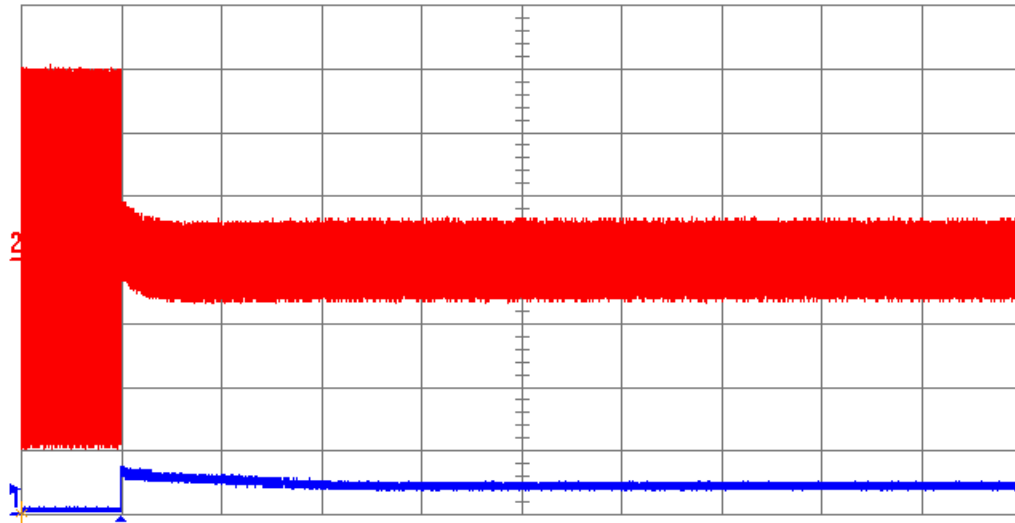

1 .1 s 50mV 2 .1 s 0.74 V

| | | |
|-----------|---|------------|
| period(1) | | --- |
| width(1) | ⌘ | 256.027 ms |
| rise(1) | ⌘ | 89 μs |
| Fall(1) | | --- |
| delay(1) | ⌘ | 0 μs |

NORMAL

Reading Floppy Disk Drive

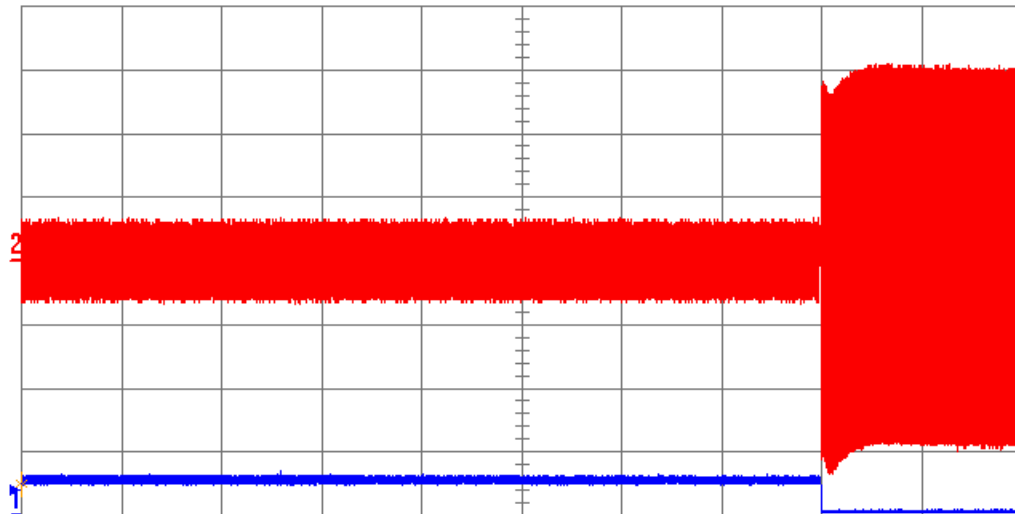

1 .1 s 50mV 2 .1 s 0.74 V

| | | |
|-----------|---|-------|
| period(1) | | --- |
| width(1) | | --- |
| rise(1) | | --- |
| Fall(1) | ↓ | 33 μs |
| delay(1) | ↓ | 4 μs |

STOPPED

Results: Meets Requirements.

Applicant: SHENZHEN CONSTANT ELECTRONICS CO., LTD.
 FCC ID: WH2-2611CA
 Report: S\SZ CONSTANT_WH2\1805AUT14\1805AUT14TestReport.docx

TEST PROCEEDURE: ANSI/TIA 603-D:2010, the levels were set as follows:

1. Using the variable attenuator the transmitter level was set to 40 dB below the test receivers maximum input level, then the transmitter was turned off.
2. With the transmitter off the signal generator was set 20dB below the level of the transmitter in the above step, this level will be maintained with the signal generator through-out the test.
3. Reduce the attenuation between the transmitter and the RF detector by 30 dB.
4. With the levels set as above, the transient frequency behavior was observed and recorded.

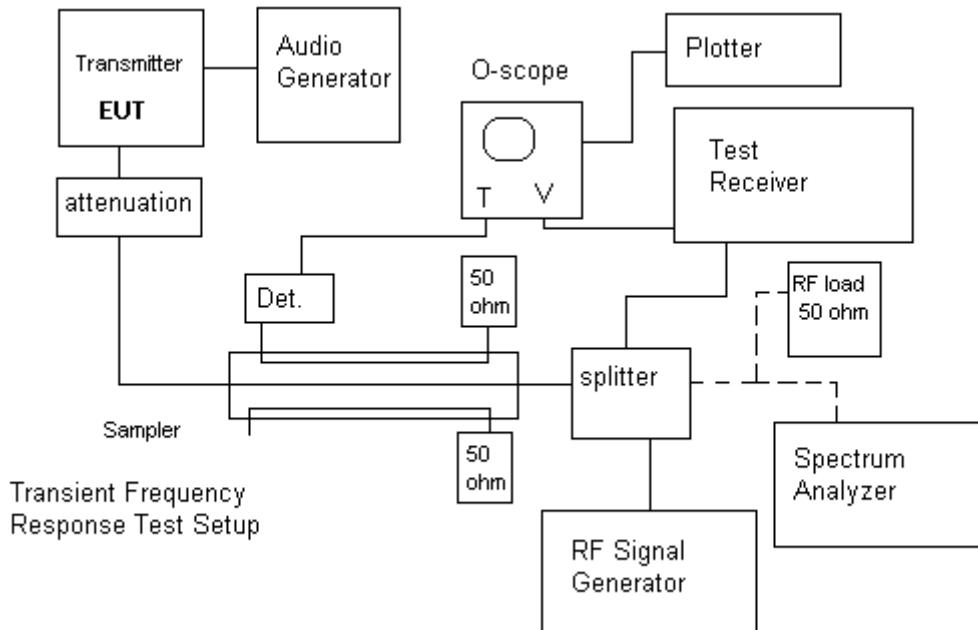

EQUIPMENT LIST

| Device | Manufacturer | Model | Serial Number | Cal/Char Date | Due Date |
|---|----------------------|---------|---------------|---------------|----------|
| Antenna: Biconnical Chamber | Eaton Chamber | 94455-1 | 1057 | 06/14/13 | 06/14/15 |
| Antenna: Log-Periodic Chamber | Eaton | 96005 | 1243 | 05/31/13 | 05/31/15 |
| LISN (Primary) | Electro-Metrics | EM-7820 | 2682 | 02/26/13 | 02/26/15 |
| Temperature Chamber LARGE | Tenney Engineering | TTRC | 11717-7 | 08/19/14 | 08/19/16 |
| AC Voltmeter | HP | 400FL | 2213A14728 | 06/26/13 | 06/26/15 |
| Frequency Counter Large Chamber | HP | 5352B | 2632A00165 | 06/26/13 | 06/26/15 |
| 3-Meter Semi-Anechoic Chamber | Panashield | N/A | N/A | 12/31/13 | 12/31/15 |
| Antenna: Double-Ridged Horn/ETS Horn 1 | ETS-Lindgren Chamber | 3117 | 00035923 | 06/13/14 | 06/13/16 |
| EMI Test Receiver R & S ESIB 40 Screen Room | Rohde & Schwarz | ESIB 40 | 100274 | 08/12/14 | 08/12/16 |
| Software: Field Strength Program | Timco | N/A | Version 4.0 | 12/12/99 | 12/12/99 |
| Hygro-Thermometer | Extech | 445703 | 0602 | 06/20/13 | 06/20/15 |
| 30 dB Attenuator | Narda | 769-30 | 10267 | 03/15/13 | 03/15/15 |
| EMI Test Receiver R & S ESU 40 Chamber | Rohde & Schwarz | ESU 40 | 100320 | 03/11/14 | 03/11/16 |

[Table of Contents](#)