

Prüfbericht-Nr.: <i>Test Report No.:</i>	50276000 001	Auftrags-Nr.: <i>Order No.:</i>	238104924	Seite 1 von 70 <i>Page 1 of 70</i>
Kunden-Referenz-Nr.: <i>Client Reference No.:</i>	N/A	Auftragsdatum: <i>Order date:</i>	07-May-2019	
Auftraggeber: <i>Client:</i>	VENCER CO., LTD. 14F-12, No.79, Sec.1, Hsin Tai Wu Rd., Hsi-Chih, New Taipei City, Taiwan 22101			
Prüfgegenstand: <i>Test item:</i>	Bluetooth True Wireless Earbud			
Bezeichnung / Typ-Nr.: <i>Identification / Type No.:</i>	VS-3xxx (X= 0-9, A-Z, indication difference of market purpose, case color and product appearance.)			
Auftrags-Inhalt: <i>Order content:</i>	FCC Part15C Test report (BT)			
Prüfgrundlage: <i>Test specification:</i>	FCC 47 CFR Part 15: Subpart C Section 15.247(FHSS)			
Wareneingangsdatum: <i>Date of receipt:</i>	14-May-2019			
Prüfmuster-Nr.: <i>Test sample No.:</i>	A000922115-001 to 004			
Prüfzeitraum: <i>Testing period:</i>	24-May-2019 – 19-Jul-2019			
Ort der Prüfung: <i>Place of testing:</i>	EMC/RF Laboratory Taipei			
Prüflaboratorium: <i>Testing laboratory:</i>	TUV Rheinland Taiwan Ltd.			
Prüfergebnis*: <i>Test result*:</i>	Pass			
Report Date / tested by: 31-Jul-2019 Jack Chang/Project Manager <i>Datum Name / Stellung Unterschrift</i> <i>Date(Report Date) Name / Position Signature</i>		kontrolliert von / reviewed by: 31-Jul-2019 Arvijn Ho/Vice General Manager <i>Datum Name / Stellung Unterschrift</i> <i>Date Name / Position Signature</i>		
Sonstiges / Other:				
Zustand des Prüfgegenstandes bei Anlieferung: <i>Condition of the test item at delivery:</i>		Prüfmuster vollständig und unbeschädigt <i>Test item complete and undamaged</i>		
<p>* Legende: 1 = sehr gut 2 = gut 3 = befriedigend 4 = ausreichend 5 = mangelhaft P(ass) = entspricht o.g. Prüfgrundlage(n) F(ail) = entspricht nicht o.g. Prüfgrundlage(n) N/A = nicht anwendbar N/T = nicht getestet</p> <p>Legend: 1 = very good 2 = good 3 = satisfactory 4 = sufficient 5 = poor P(ass) = passed a.m. test specification(s) F(ail) = failed a.m. test specification(s) N/A = not applicable N/T = not tested</p>				
<p>Dieser Prüfbericht bezieht sich nur auf das o.g. Prüfmuster und darf ohne Genehmigung der Prüfstelle nicht auszugsweise vervielfältigt werden. Dieser Bericht berechtigt nicht zur Verwendung eines Prüfzeichens. <i>This test report only relates to the a. m. test sample. Without permission of the test center this test report is not permitted to be duplicated in extracts. This test report does not entitle to carry any test mark.</i></p>				

TEST SUMMARY

5.1.1 ANTENNA REQUIREMENT*RESULT: Passed***5.1.2 MAXIMUM CONDUCTED OUTPUT POWER***RESULT: Passed***5.1.3 20dB BANDWIDTH***RESULT: N/A***5.1.4 CONDUCTED SPURIOUS EMISSIONS AND FREQUENCY BAND EDGE MEASURED IN 100KHZ BANDWIDTH***RESULT: Passed***5.1.5 SPURIOUS EMISSION***RESULT: Passed***5.1.6 FREQUENCY SEPARATION***RESULT: Passed***5.1.7 NUMBER OF HOPPING FREQUENCY***RESULT: Passed***5.1.8 TIME OF OCCUPANCY***RESULT: Passed***5.2.1 MAINS CONDUCTED EMISSIONS***RESULT: Passed***6.1.1 ELECTROMAGNETIC FIELDS***RESULT: Passed*

Contents

1.	GENERAL REMARKS	5
1.1	COMPLEMENTARY MATERIALS	5
1.2	DECISION RULE OF CONFORMITY	5
2.	TEST SITES	6
2.1	TEST LABORATORY	6
2.2	TEST FACILITY.....	6
2.3	LIST OF TEST AND MEASUREMENT INSTRUMENTS	7
2.4	TRACEABILITY	8
2.5	CALIBRATION	8
2.6	MEASUREMENT UNCERTAINTY	8
3.	GENERAL PRODUCT INFORMATION.....	9
3.1	PRODUCT FUNCTION AND INTENDED USE	9
3.2	SYSTEM DETAILS AND RATINGS.....	9
3.3	INDEPENDENT OPERATION MODES	10
3.4	NOISE GENERATING AND NOISE SUPPRESSING PARTS	11
3.5	SUBMITTED DOCUMENTS	11
4.	TEST SET-UP AND OPERATION MODES	12
4.1	PRINCIPLE OF CONFIGURATION SELECTION	12
4.2	TEST OPERATION AND TEST SOFTWARE.....	12
4.3	SPECIAL ACCESSORIES AND AUXILIARY EQUIPMENT	13
4.4	COUNTERMEASURES TO ACHIEVE EMC COMPLIANCE.....	13
4.5	TEST SETUP DIAGRAM	14
5.	TEST RESULTS	16
5.1	TRANSMITTER REQUIREMENT & TEST SUITES	16
5.1.1	<i>Antenna Requirement</i>	<i>16</i>
5.1.2	<i>Maximum conducted output power</i>	<i>17</i>
5.1.3	<i>20dB Bandwidth</i>	<i>19</i>
5.1.4	<i>Conducted spurious emissions and Frequency Band Edge measured in 100kHz Bandwidth.....</i>	<i>27</i>
5.1.5	<i>Spurious Emission</i>	<i>42</i>
5.1.6	<i>Frequency Separation.....</i>	<i>43</i>
5.1.7	<i>Number of hopping frequency.....</i>	<i>47</i>
5.1.8	<i>Time of Occupancy</i>	<i>52</i>
5.2	MAINS EMISSIONS.....	58
5.2.1	<i>Mains Conducted Emissions.....</i>	<i>58</i>

Produkte
Products

Prüfbericht - Nr.: 50276000 001
Test Report No.

Seite 4 von 70
Page 4 of 70

6.	SAFETY HUMAN EXPOSURE	59
6.1	RADIO FREQUENCY EXPOSURE COMPLIANCE	59
6.1.1	<i>Electromagnetic Fields.....</i>	<i>59</i>
7.	PHOTOGRAPHS OF THE TEST SET-UP.....	60
8.	LIST OF TABLES	70
9.	LIST OF PHOTOGRAPHS.....	70

1. General Remarks

1.1 Complementary Materials

The following attachments are integral parts of this test report:

Appendix P: Photo Documentation

(File Name: 50276000 001 APPENDIXP)

Appendix D: Test Result of Radiated Emissions

(File Name: 50276000 001 APPENDIXD)

Test Specifications

The following standards were applied.

Table 1: Applied Standard and Test Levels

Radio
FCC 47CFR Part 15: Subpart C Section 15.247
FCC 47CFR Part 2: Subpart J Section 2.1091
ANSI C63.10:2013
KDB558074 D01 DTS Meas Guidance v05r02
KDB447498 D01 General RF Exposure Guidance v06

1.2 Decision Rule of conformity

The decision rule of conformity of this test report is following the requirements of the requested standard in the quotation, and agreed among testing laboratory and manufacturer (applicant) to exclude the consideration of Measurement Uncertainty, unless it is required by the specific standard.

2. Test Sites

2.1 Test Laboratory

TUV Rheinland Taiwan Ltd.
Taichung Branch Office

No.9, Lane 36, Minsheng Rd., Sec. 3, Daya District,
Taichung City 428
Taiwan (R.O.C.)

2.2 Test Facility

TUV Rheinland Taiwan Ltd.

11F. No.758, Sec. 4, Bade Rd., Songshan Dist.
Taipei City 105
Taiwan (R.O.C.)

TAF Accredited NCC Test Lab. No.:3567
TAF ISO17025 Certification effective period: 6th-May-2019 to 05th-May-2022



Testing Laboratory
3567

2.3 List of Test and Measurement Instruments

Table 2: List of Test and Measurement Equipment

Kind of Equipment	Manu-facturer	Type	S/N	Last Calibration	Next Calibration
Test Software	Farad	EZ_EMCC	Ver. TUV3A1	N/A	N/A
EMI Test Receiver	R&S	ESR 7	101062	2018/10/01	2019/10/01
Spectrum Analyzer	R&S	FSV 40	101514	2019/02/07	2020/02/07
EXA Signal Analyzer	KEYSIGHT	N9010A	MY52221334	2019/02/15	2020/02/15
Preamplifier (30MHz -1GHz)	HP	8447F	2805A03335	2018/08/22	2019/08/22
Pre-Amplifier (1GHz~18GHz)	EM Electronics	EM01G18G	060558	2018/11/30	2019/11/30
Bilog Antenna	TESEQ	CBL 6111D	29802	2018/08/22	2019/08/22
Horn Antenna	ETS-Lindgren	3117	00218931	2018/12/27	2019/12/27
Horn Antenna (18GHz~40GHz)	COM-POWER	AH-840	101029	2018/12/22	2019/12/22
Loop Antenna	Schwarzbeck	FMZB 1513**	1513-076	2018/06/21	2019/06/21
EMI Test Receiver	Rohde & Schwarz	ESCI 7*	100797	2019/01/16	2020/01/16
Two-Line V-Network	Rohde & Schwarz	ENV216*	101262	2018/07/10	2019/07/10

*ESCI 7 and ENV216 are using for AC mains testing, and the tested date is 24th May 2019.

**FMZB 1513 is using for 9KHz to 1GHz of radiated testing, and the tested date is 10th Jun 2019 and 12th Jun 2019.

2.4 Traceability

All measurement equipment calibrations are traceable to NML(Taiwan)/NIST(USA) or where calibration is performed outside Taiwan, to equivalent nationally recognized standards organizations.

2.5 Calibration

Equipment requiring calibration is calibrated periodically by the manufacturer or according to manufacturer's specifications. Additionally all equipment is verified for proper performance on a regular basis using in house standards or comparisons.

2.6 Measurement Uncertainty

The estimated combined standard uncertainty for radiated emissions and conducted emissions measurements are $\pm 3\text{dB}$.

Table 3: Emission Measurement Uncertainty

Parameter	Uncertainty
RF power, conducted	$\pm 1.5 \text{ dB}$
Adjacent channel power	$\pm 3 \text{ dB}$
Radiated emission of transmitter, valid up to 26 GHz	$\pm 6 \text{ dB}$
Radiated emission of receiver, valid up to 26 GHz	$\pm 6 \text{ dB}$
Temperature	$\pm 2 \text{ }^\circ\text{C}$
Humidity	$\pm 10 \text{ } \%$

3. General Product Information

3.1 Product Function and Intended Use

The EUT is a Bluetooth True Wireless Earbud. It contains a Bluetooth compatible module enabling the user to communicate data through a Wireless interface.

For details refer to the User Guide, Data Sheet and Circuit Diagram.

3.2 System Details and Ratings

Table 4: Basic Information of EUT

Item	EUT information
Kind of Equipment/Test Item	Bluetooth True Wireless Earbud
Type Identification	VS-3xxx (X= 0-9, A-Z, indication difference of market purpose, case color and product appearance.)
FCC ID	VHVBTVS3000

Table 5: Technical Specification of EUT

Technical Specification	Value
Operating Frequency	2402 MHz ~ 2480 MHz
Channel Spacing	1 MHz
Channel number	79
Operation Voltage	4Vdc
Modulation	GFSK, $\pi/4$ DQPSK, 8DPSK
Antenna gain	-6.23dBi

Table 6: Frequency hopping information

Technical Specification	Description
Hopping Range	Hereby we declare that the maximum frequency of this device is: 2402-2480MHz. This is according the Bluetooth Core Specification v5.0 for devices which will be operated in the USA. This was checked during the Bluetooth Qualification tests (Test Case: TRM/CA/04).
Hopping Sequence	Example of a 79 hopping sequence in data mode: 33,04,21,44,23,42,53,46,55,48,40,59,72,29,76,31,08,73,07,75,09,45,60,39,58,13,47,11,77,52,35,50,65,54,67,56,69,62,71,64, 7,25,27,66,57,70,74,61,78,63,10,41,05,43,15,44,64,68,02,70,06,01,51,03,55,05,03,66,53,49,36,47,
Receiver input bandwidth	<p>The input bandwidth of the receiver is 1MHz. In every connection one Bluetooth device is the master and the other one is the slave. The master determines the hopping sequence. The slave follows this sequence. Both devices shift between RX and TX time slot according to the clock of the master.</p> <p>Additionally the type of connection is set up at the beginning of the connection. The master adapts its hopping frequency and its TX/RX timing according to the packet type of the connection. Also the slave of the connection will use these settings.</p> <p>Repeating of a packer has no influence on the hopping sequence. The hopping sequence generated by the master of the connection will be followed in any case.</p> <p>That means a repeated packet will not be send on the same frequency, it is send on the next frequency of the hopping sequence.</p>

3.3 Independent Operation Modes

The basic operation modes are:

- A. Transmitting
 - 1. Low channel
 - 2. Middle channel
 - 3. High channel
- B. Hopping

3.4 Noise Generating and Noise Suppressing Parts

Refer to the Circuit Diagram.

3.5 Submitted Documents

- Photo Document
- Technical Description
- Rating Label
- Circuit Diagram
- Block Diagram

4. Test Set-up and Operation Modes

4.1 Principle of Configuration Selection

The equipment under test (EUT) was configured to measure its maximum power level. The test modes were adapted accordingly in reference to the instructions for use.

4.2 Test Operation and Test Software

Setup for testing: The Test samples are provided with a USB interface which makes it possible to control the module through the test software installed on a notebook computer.

This software was running on the laptop computer connected to the EUT. It was used to enable the operation modes listed in section 3.3 as appropriate.

The samples were used as follows:

Conducted sample (Left Ear): A000922115-003
Conducted sample (Right Ear): A000922115-004
Radiation sample (Left Ear): A000922115-001
Radiation sample (Right Ear): A000922115-002

Full test was applied on all test modes, but only worst case was shown

4.3 Special Accessories and Auxiliary Equipment

The product has been tested together with the following additional accessories:

Description	Manufacturer	Model No.	Serial No.
Notebook(EMC-06)	Lenovo	TP00048A	PB-0F8B2
Bluetooth Tester	R&S	CMW270	-
Test tool	Qualcomm	QTIL	3.2.0
Adapter for AC mains	Apple	A1401	-

4.4 Countermeasures to achieve EMC Compliance

The test sample which has been tested contained the noise suppression parts as described in the Constructional Data Form or the Technical Construction File. No additional measures were employed to achieve compliance.

4.5 Test Setup Diagram

Diagram of Measurement Configuration for Radiation Test

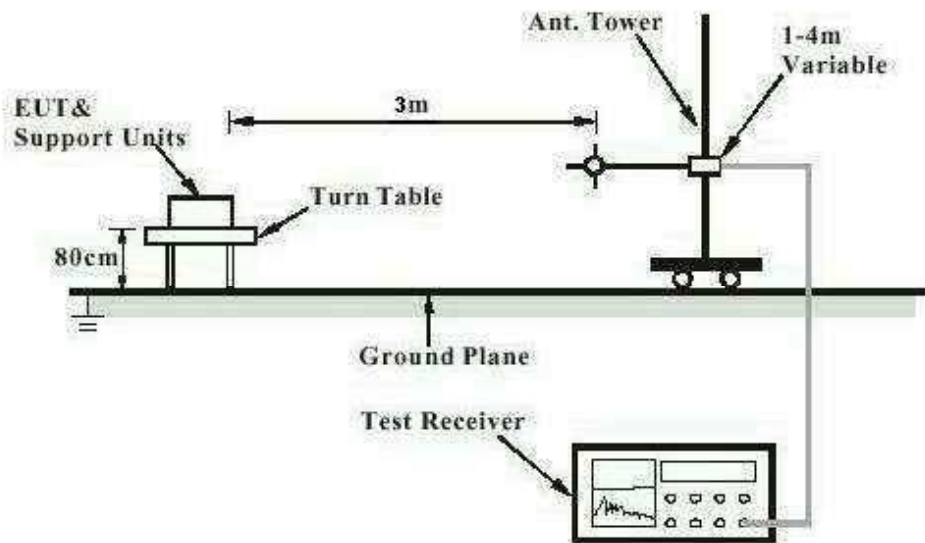

Note: Measurements above 1 GHz are done with a table height of 1.5m

Diagram of Measurement Equipment Configuration for Mains Conduction Measurement

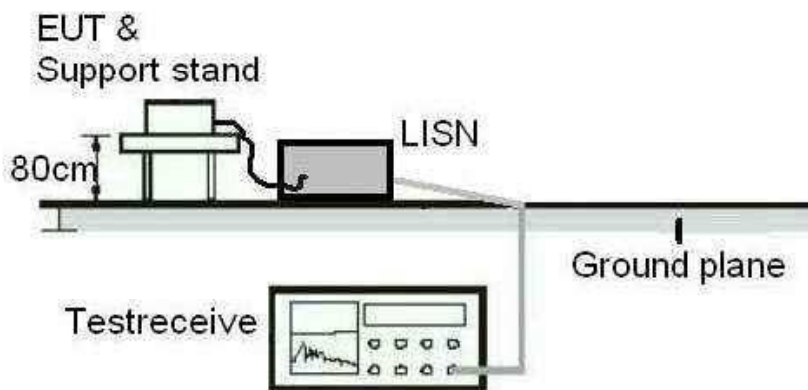
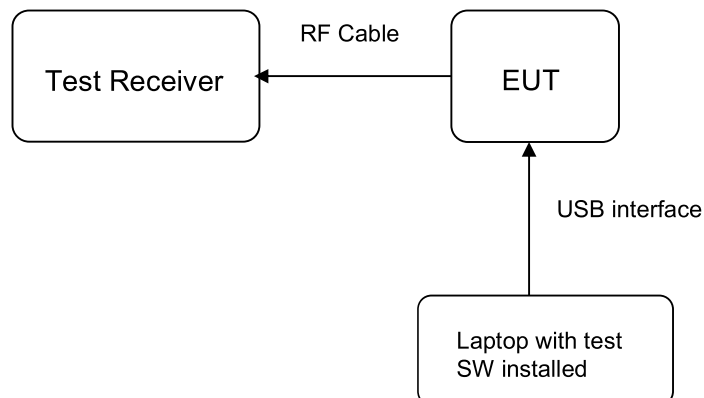

Diagram of Measurement Equipment Configuration for Conducted Transmitter Measurement



5. Test Results

5.1 Transmitter Requirement & Test Suites

5.1.1 Antenna Requirement

RESULT: **Passed**

Test standard : FCC Part 15.247(b)(4), Part 15.203

Requirement : use of approved antennas only with directional gains that do not exceed 6 dBi

According to the manufacturer declaration, the EUT has an antenna with Max directional gain of -6.23dBi. The antenna is a Metal Stamping Antenna with no possibility of replacement with a non-approved antenna by the end-user. Therefore, the EUT is considered to comply with this provision.

Refer to EUT photo for details.

5.1.2 Maximum conducted output power

RESULT:
Passed

Test standard : FCC Part 15.247(b)(1)
 Basic standard : ANSI C63.10:2013
 Kind of test site : Conducted room

Test setup

Test Channel : Low/ Middle/ High
 Operation Mode : A

Ambient temperature : 18-25 °C
 Relative humidity : 50-65 %
 Atmospheric pressure : 100-103kPa

Table 7: Test result of Maximum conducted output power, GFSK modulation – Left Ear

Channel	Channel Frequency	Peak Output Power		Limit	Power Setting
	(MHz)	(dBm)	(W)	(W)	
Low Channel	2402	0.98	0.00125	0.125	0,-3,0
Middle Channel	2441	1.32	0.00136	0.125	0,-3,0
High Channel	2480	-0.69	0.00085	0.125	0,-6,0

Table 8: Test result of Maximum conducted output power, 8DPSK modulation – Left Ear

Channel	Channel Frequency	Peak Output Power		Limit	Power Setting
	(MHz)	(dBm)	(W)	(W)	
Low Channel	2402	1.42	0.00139	0.125	0,-6,0
Middle Channel	2441	0.10	0.00102	0.125	0,-8,0
High Channel	2480	0.32	0.00108	0.125	0,-8,0

Maximum Output power: 1.39mW

Table 9: Test result of Maximum conducted output power, GFSK modulation – Right Ear

Channel	Channel Frequency	Peak Output Power		Limit	Power Setting
	(MHz)	(dBm)	(W)	(W)	
Low Channel	2402	7.96	0.00625	0.125	0,0,0
Middle Channel	2441	7.53	0.00566	0.125	0,0,0
High Channel	2480	4.79	0.00301	0.125	0,0,0

Table 10: Test result of Maximum conducted output power, 8DPSK modulation – Right Ear

Channel	Channel Frequency	Peak Output Power		Limit	Power Setting
	(MHz)	(dBm)	(W)	(W)	
Low Channel	2402	7.95	0.00624	0.125	0,-5,0
Middle Channel	2441	7.49	0.00561	0.125	0,-5,0
High Channel	2480	7.72	0.00592	0.125	0,-5,0

Maximum Output power: 6.25mW

5.1.3 20dB Bandwidth

RESULT: **N/A**

Test standard : FCC Part 15.247(a)(1)
 Basic standard : ANSI C63.10:2013
 Kind of test site : Shielded room

Test setup

Test Channel : Low/ Middle/ High
 Operation Mode : A

Ambient temperature : 18-25°C
 Relative humidity : 50-65%
 Atmospheric pressure : 100-103kPa

Table 11: Test result of 20dB Bandwidth, GFSK modulation – Left Ear

Channel	Channel Frequency (MHz)	20dB Bandwidth (MHz)
Low Channel	2402	0.9617
Mid Channel	2441	0.9600
High Channel	2480	0.9604

Note: For reporting purposes only.

Table 12: Test result of 20dB Bandwidth, 8DPSK modulation – Left Ear

Channel	Channel Frequency (MHz)	20dB Bandwidth (MHz)
Low Channel	2402	1.310
Mid Channel	2441	1.309
High Channel	2480	1.308

Note: For reporting purposes only.

Test Plot of 20dB Bandwidth, GFSK modulation

Low Channel



Middle Channel



High Channel



Test Plot of 20dB Bandwidth, 8DPSK modulation

Low Channel



Middle Channel

High Channel

Table 13: Test result of 20dB Bandwidth, GFSK modulation – Right Ear

Channel	Channel Frequency (MHz)	20dB Bandwidth (MHz)
Low Channel	2402	0.9621
Mid Channel	2441	0.9628
High Channel	2480	0.9609

Note: For reporting purposes only.

Table 14: Test result of 20dB Bandwidth, 8DPSK modulation – Right Ear

Channel	Channel Frequency (MHz)	20dB Bandwidth (MHz)
Low Channel	2402	1.308
Mid Channel	2441	1.311
High Channel	2480	1.311

Note: For reporting purposes only.

Test Plot of 20dB Bandwidth, GFSK modulation

Low Channel



Middle Channel



High Channel



Test Plot of 20dB Bandwidth, 8DPSK modulation

Low Channel



Middle Channel

High Channel

5.1.4 Conducted spurious emissions and Frequency Band Edge measured in 100kHz Bandwidth

RESULT: **Passed**

Test standard	:	FCC part 15.247(d)
Basic standard	:	ANSI C63.10:2013, KDB558074
Limit	:	20dB (below that in the 100kHz bandwidth within the band that contains the highest level of the desired power)
Kind of test site	:	Conducted room

Test setup

Test Channel	:	Low/ Mid/ High for spurious, Low/ High for Band Edge
Operation Mode	:	A
Ambient temperature	:	18-25°C
Relative humidity	:	50-65%
Atmospheric pressure	:	100-103kPa

All emissions are more than 20dB below fundamental, details refer to following test plot, and compliance is achieved as well.

Due to the small size of the product and that there are no inductive components of significant size ,9kHz to 30MHz frequency range is not tested based on technical judgment.

Test Plot of 100kHz Bandwidth of Frequency Band Edge, GFSK modulation – Left Ear

Low Channel

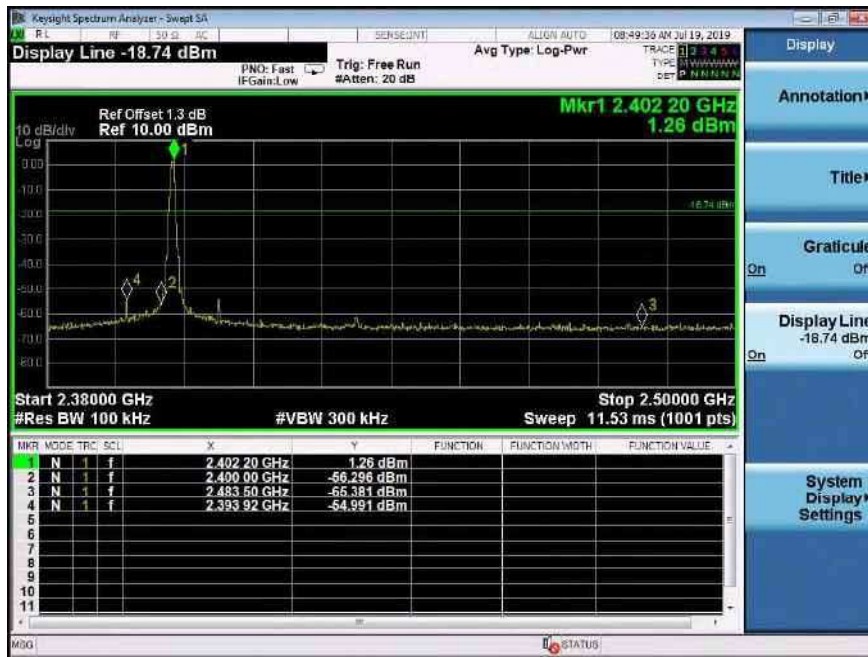

High Channel

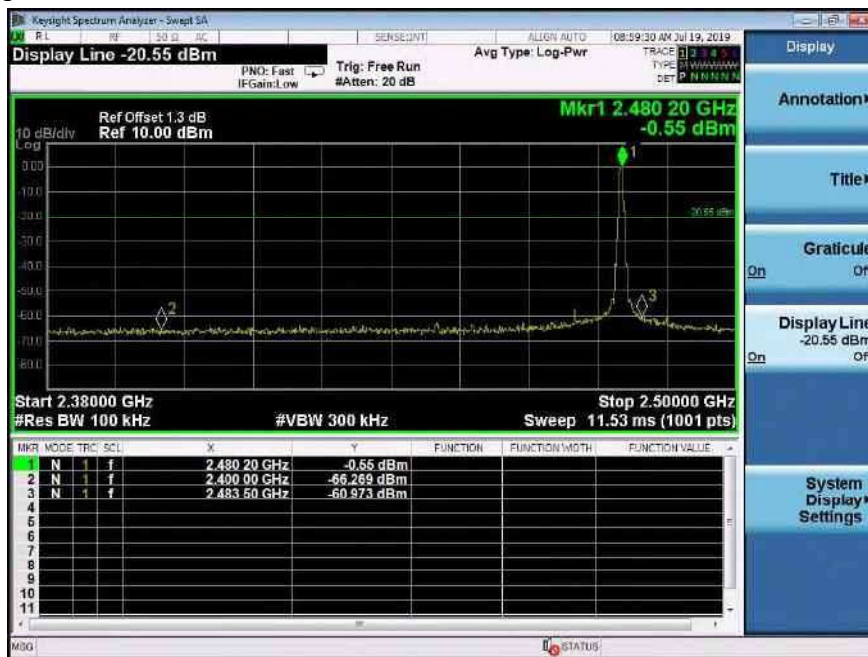

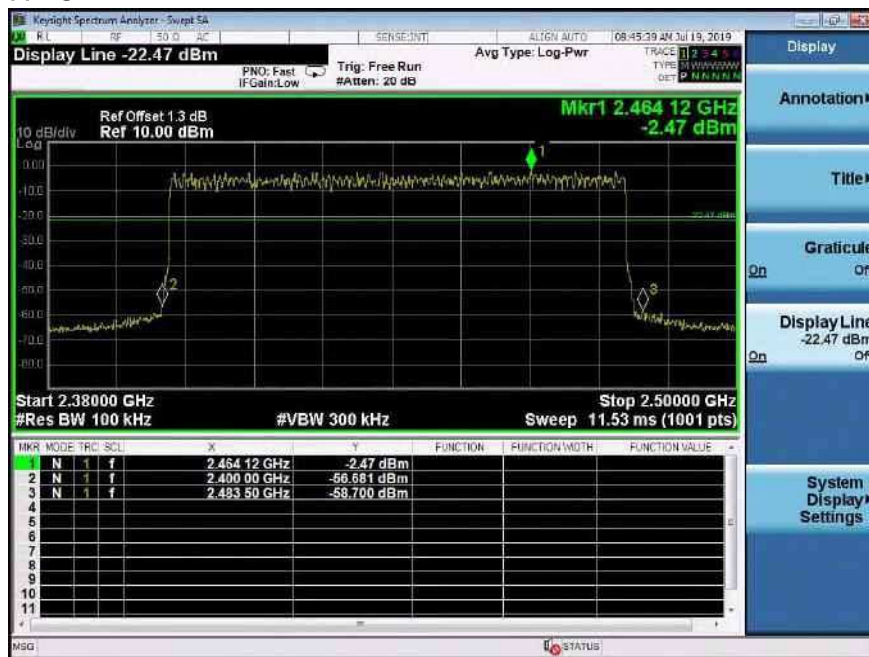
Hopping ON

Test Plot of 100kHz Conducted Emissions, GFSK modulation – Right Ear
Low Channel

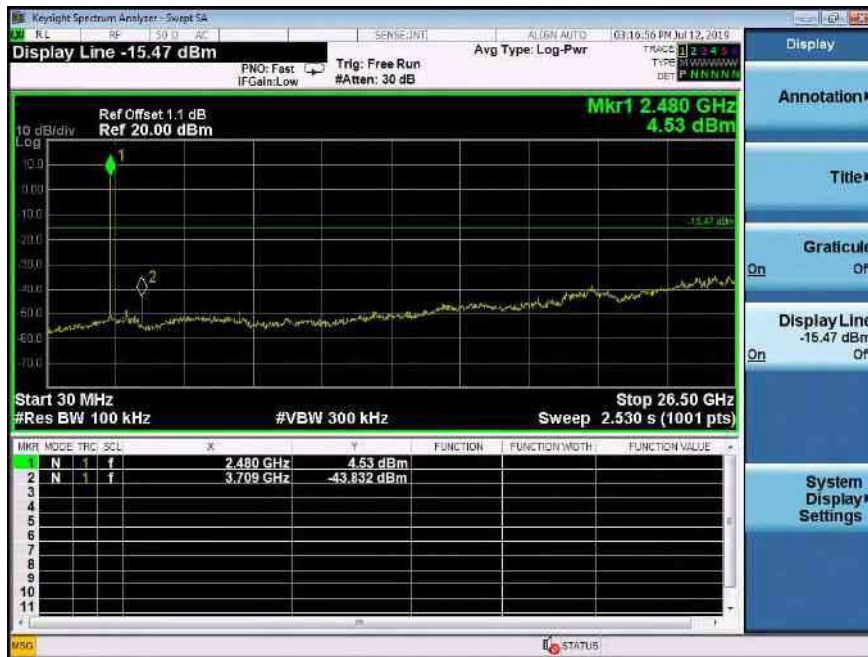
Middle Channel

High Channel

Test Plot of 100kHz Bandwidth of Frequency Band Edge, GFSK modulation – Right Ear

Low Channel



High Channel

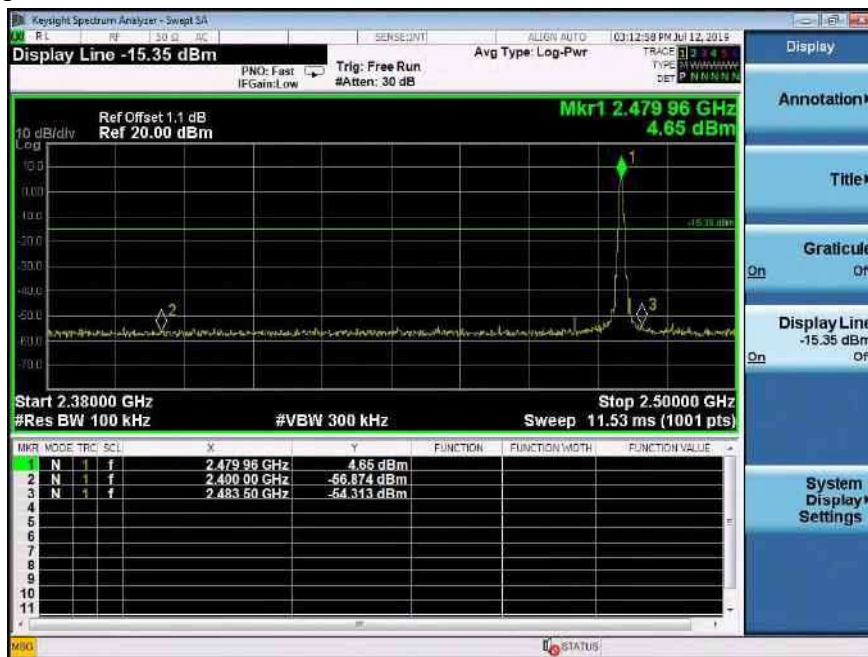

5.1.5 Spurious Emission

RESULT:**Passed**

Test standard	:	FCC part 15.247(d), FCC 15.205, FCC 15.209
Basic standard	:	ANSI C63.10
Limits	:	Radiated emissions which fall in the restricted bands, as defined in FCC 15.205(a), must comply with the radiated emission limits specified in FCC 15.209(a). Emission radiated outside the specified frequency bands must comply with the radiated emission limits specified in FCC 15.209(a).
Kind of test site	:	3m Semi-Anechoic Chamber

Test setup

Test Channel	:	Low/ Middle/ High
Operation Mode	:	A

For details refer to Appendix D.

The Radiated Emissions testing was performed in the X, Y and Z axis orientation. The worst-case Axis orientation is recorded in this test report.

Factor (dB/m)=Antenna Factor(dB/m)+Cable loss (dB)

Level(dBuV/m)=Reading(dBuV)+ Factor(dB/m)

5.1.6 Frequency Separation

RESULT: **Passed**

Test standard : FCC part 15.247(a)(1)
 Basic standard : ANSI C63.10:2013
 Limit : $\geq 25\text{kHz}$ or $2/3$ of 20dB bandwidth, whichever is greater

Test setup

Operation Mode : B
 Ambient temperature : 18-25°C
 Relative humidity : 50-65%

Table 15: Test result of Frequency Separation (GFSK) – Left Ear

Channel	Channel Frequency (MHz)	Measured Channel Separation (MHz)	Limit (kHz)	Result
Record Channel	2440	1	$\geq 25\text{kHz}$ or $2/3$ of 20dB bandwidth	Pass
Record Channel adj 1	2441			
Record Channel adj 2	2442			

Table 16: Test result of Frequency Separation (8DPSK) – Left Ear

Channel	Channel Frequency (MHz)	Measured Channel Separation (MHz)	Limit (kHz)	Result
Record Channel	2440	1	$\geq 25\text{kHz}$ or $2/3$ of 20dB bandwidth	Pass
Record Channel adj 1	2441			
Record Channel adj 2	2442			

Table 17: Test result of Frequency Separation (GFSK) – Right Ear

Channel	Channel Frequency (MHz)	Measured Channel Separation (MHz)	Limit (kHz)	Result
Record Channel	2440	1	≥ 25kHz or 2/3 of 20dB bandwidth	Pass
Record Channel adj 1	2441			
Record Channel adj 2	2442			

Table 18: Test result of Frequency Separation (8DPSK) – Right Ear

Channel	Channel Frequency (MHz)	Measured Channel Separation (MHz)	Limit (kHz)	Result
Record Channel	2440	1	≥ 25kHz or 2/3 of 20dB bandwidth	Pass
Record Channel adj 1	2441			
Record Channel adj 2	2442			

Test Plot of Frequency Separation, Right Ear
GFSK

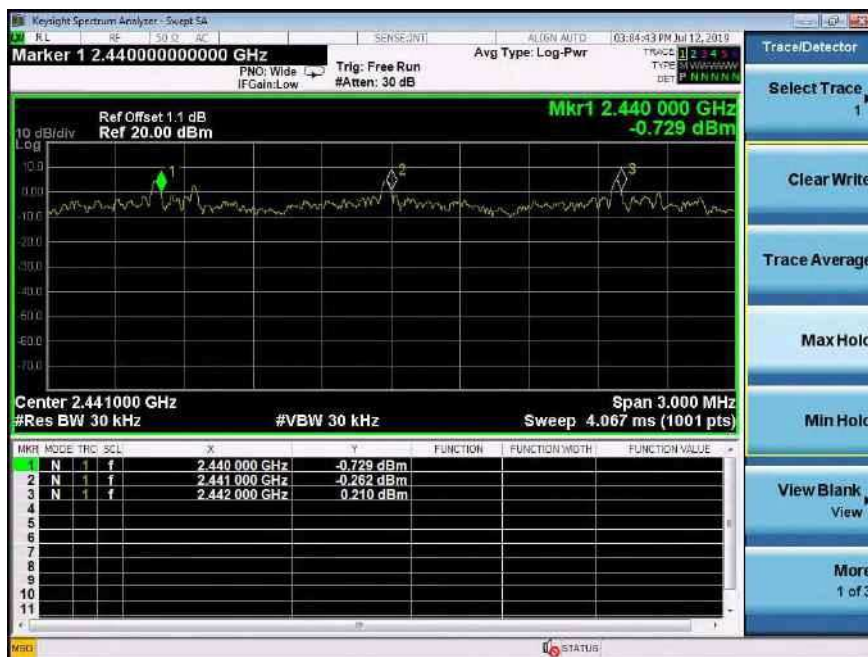
8DPSK

5.1.7 Number of hopping frequency

RESULT:
Passed

Test standard : FCC part 15.247(a)(1)(iii)
 Basic standard : ANSI C63.10:2013
 Limits : ≥ 15 non-overlapping channels
 Kind of test site : Shield room

Test setup

Test Channel : Hopping On

Ambient temperature : 18-25°C
 Relative humidity : 50-65%
 Atmospheric pressure : 100-103kPa

Table 19: Test result of Number of hopping frequency – Left Ear

Frequency Range	Measured Quantity of Hopping Channel	Limit	Result
<u>2400</u> to <u>2483.5</u> MHz	79	≥ 15	Pass

Table 20: Test result of Number of hopping frequency – Right Ear

Frequency Range	Measured Quantity of Hopping Channel	Limit	Result
<u>2400</u> to <u>2483.5</u> MHz	79	≥ 15	Pass

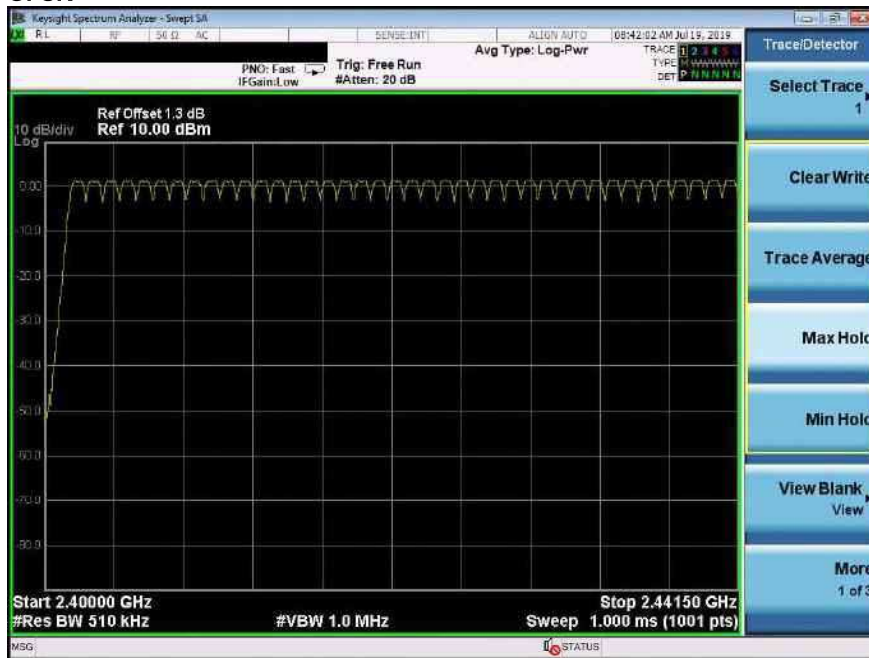
**Test Plot of Number of hopping frequencies – Left Ear
 GFSK**

8DPSK

**Test Plot of Number of hopping frequencies – Right Ear
GFSK**

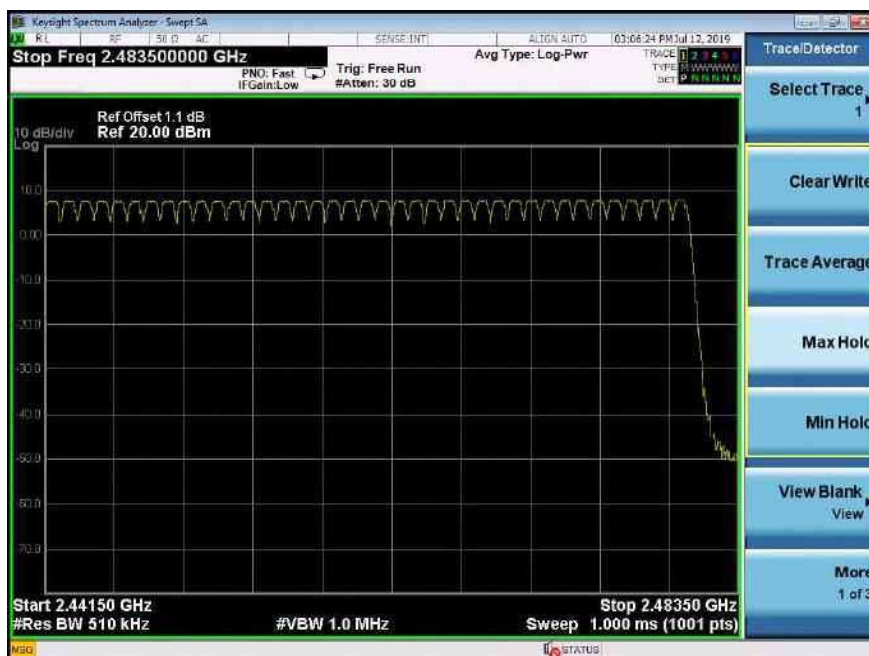
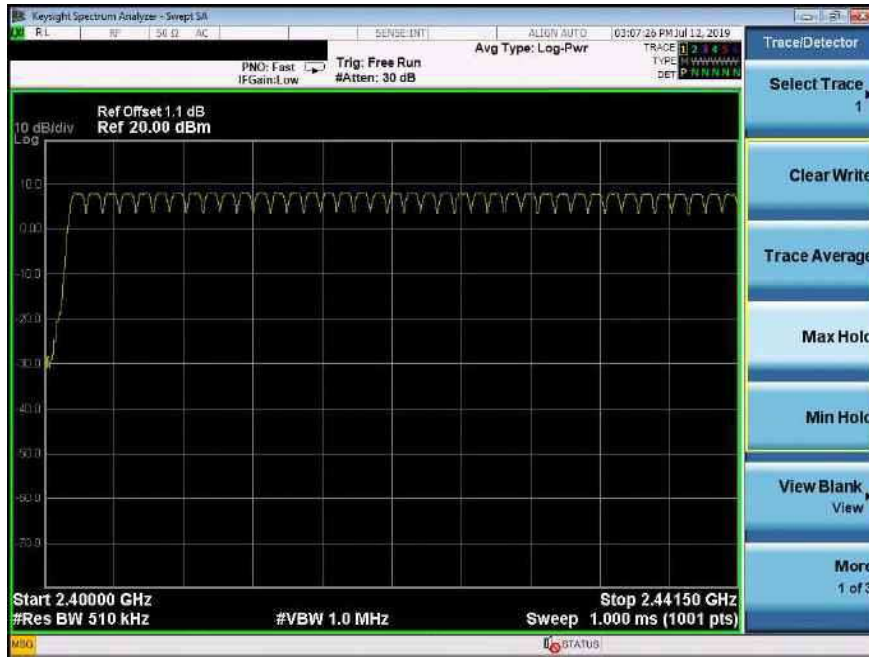

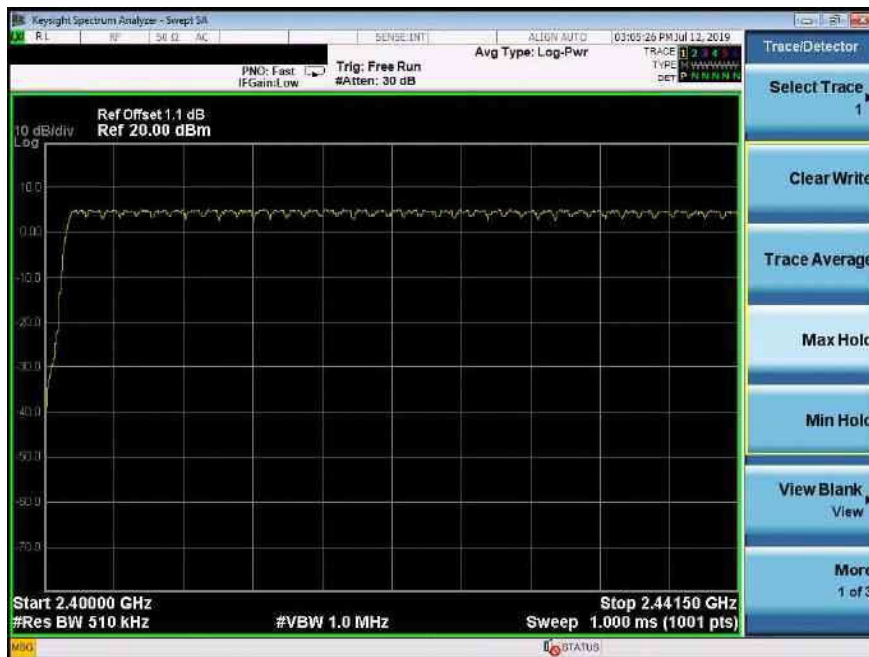
8DPSK

5.1.8 Time of Occupancy

RESULT: **Passed**

Test standard : FCC part 15.247(a)(1)(iii)
 Basic standard : ANSI C63.10:2013
 Limits : 0.4s
 Kind of test site : Conducted room

Test setup

Test Channel : Low
 Operation Mode : A

 Ambient temperature : 18-25°C
 Relative humidity : 50-65%
 Atmospheric pressure : 100-103kPa

Table 21: Test result of Time of Occupancy – Left Ear

Data Mode	Captured Burst (s)	Dwell time (s)	On+Off time (s)	Limit (s)	Result
DH5	0.00290	0.3093	0.00375	0.4	Pass
3DH5	0.00290	0.3102	0.00374	0.4	Pass

Note:

Dwell time = Pulse width x (Hopping rate / Number of channels) x Period

Period = 0.4 (seconds/ channel) x 79 (channel) = 31.6 seconds.

Hopping rate = 1 / (On+Off time)

Hopping Rate for DH5 = 266 Hz
 Hopping Rate for 3DH5 = 268 Hz

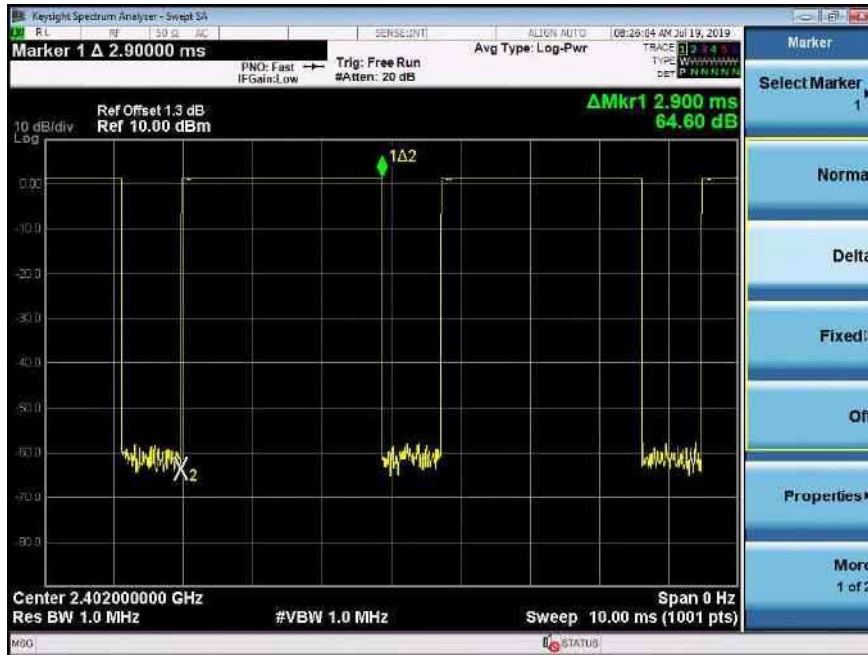
Test Plot of Time of Occupancy, GFSK modulation

Test Plot of Time of Occupancy, 8DPSK modulation

Table 22: Test result of Time of Occupancy – Right Ear

Data Mode	Captured Burst (s)	Dwell time (s)	On+Off time (s)	Limit (s)	Result
DH5	0.00286	0.3051	0.00375	0.4	Pass
3DH5	0.00289	0.3083	0.00375	0.4	Pass

Note:

Dwell time = Pulse width x (Hopping rate / Number of channels) x Period

Period = 0.4 (seconds/ channel) x 79 (channel) = 31.6 seconds.

Hopping rate = 1 / (On+Off time)

Hopping Rate for DH5 = 266 Hz

Hopping Rate for 3DH5 = 268 Hz

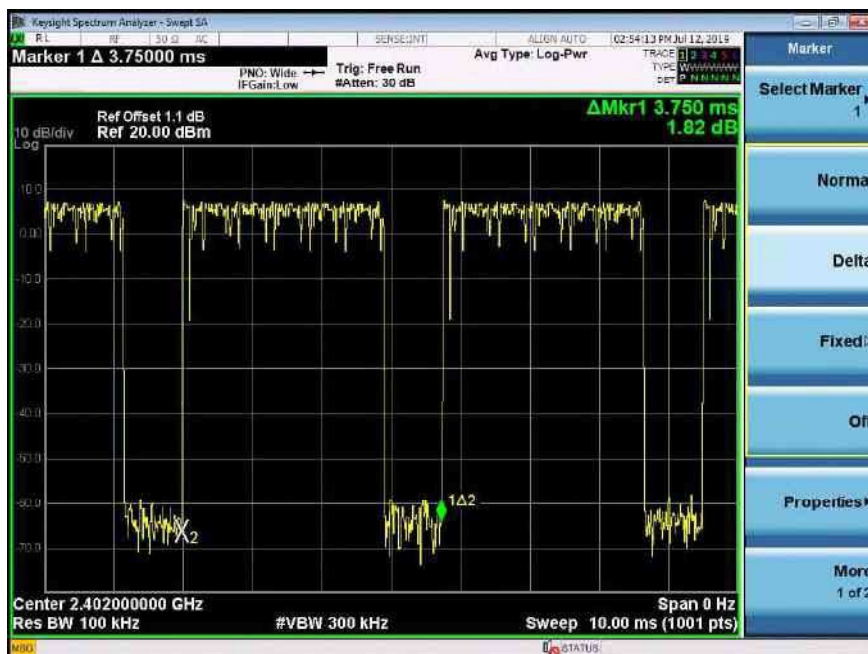
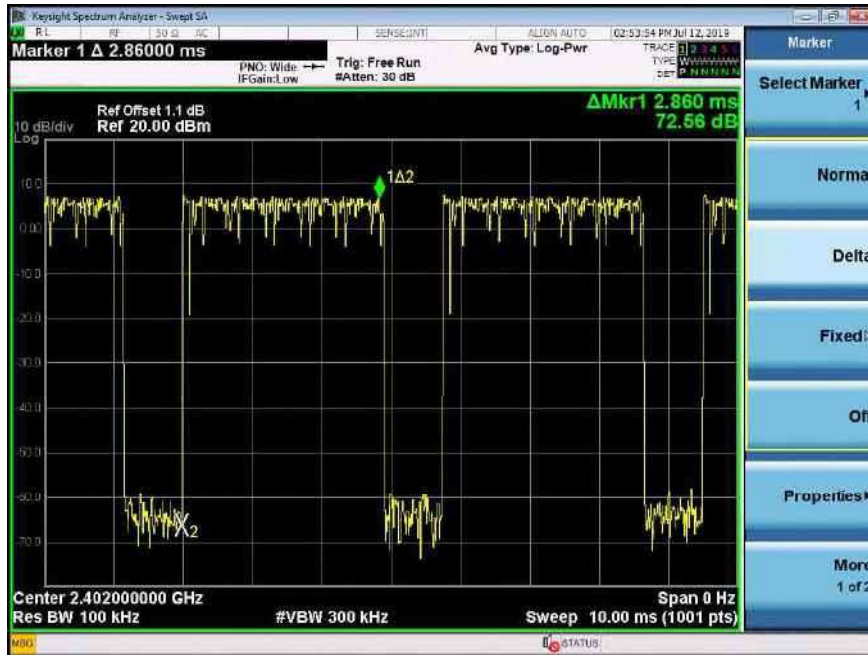
Test Plot of Time of Occupancy, GFSK modulation

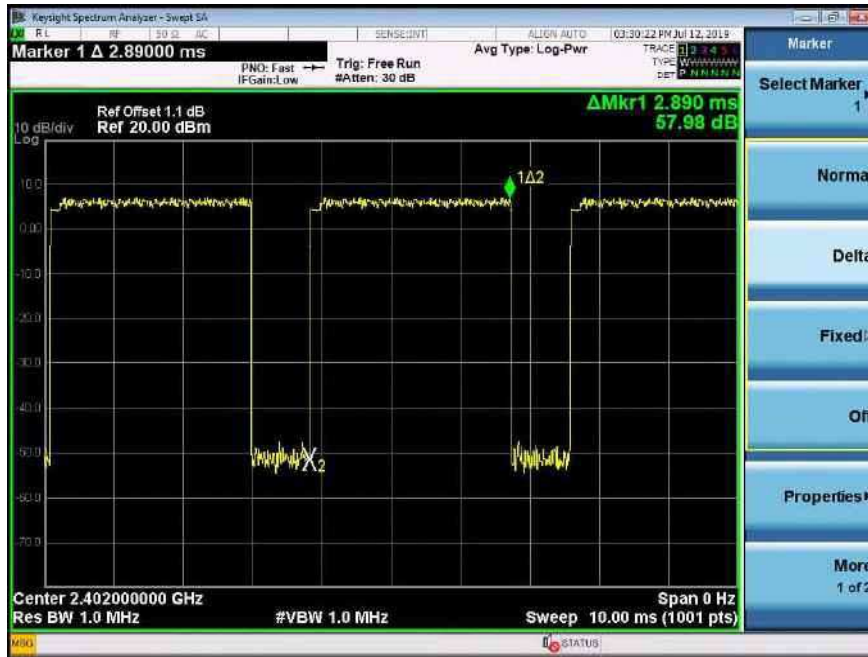
Test Plot of Time of Occupancy, 8DPSK modulation

5.2 Mains Emissions

5.2.1 Mains Conducted Emissions

RESULT:**Passed**

Test standard : FCC Part 15.207
FCC Part 15.107
Limits : Mains Conducted emissions as defined in
above test standards must comply with the
mains conducted emission limits specified
Kind of test site : Shielded Room

Test setup

Test Channel : Middle
Operation mode : A

Remark: For details refer to Appendix D.

6. Safety Human exposure

6.1 Radio Frequency Exposure Compliance

6.1.1 Electromagnetic Fields

RESULT:**Passed**

Test standard : FCC KDB Publication 447498 D01 v06
47CFR 1.1310
47CFR 2.1091

Left Ear:

Therefore the maximum output power of the transmitter is $1.39\text{mW} < 10\text{mW}$ (Distance: 5mm), hence the EUT is excluded from SAR evaluation according to FCC KDB publication 447498 D01: Mobile Portable RF Exposure.

Right Ear:

Therefore the maximum output power of the transmitter is $6.25\text{mW} < 10\text{mW}$ (Distance: 5mm), hence the EUT is excluded from SAR evaluation according to FCC KDB publication 447498 D01: Mobile Portable RF Exposure.

---End---

7. Photographs of the Test Set-Up

Photograph 1: Set-up for Spurious Emissions (Front View 1) – Left Ear



Photograph 2: Set-up for Spurious Emissions (Front View 2) – Left Ear



Photograph 3: Set-up for Spurious Emissions (Back View 1) – Left Ear



Photograph 4: Set-up for Spurious Emissions (Back View 2) – Left Ear

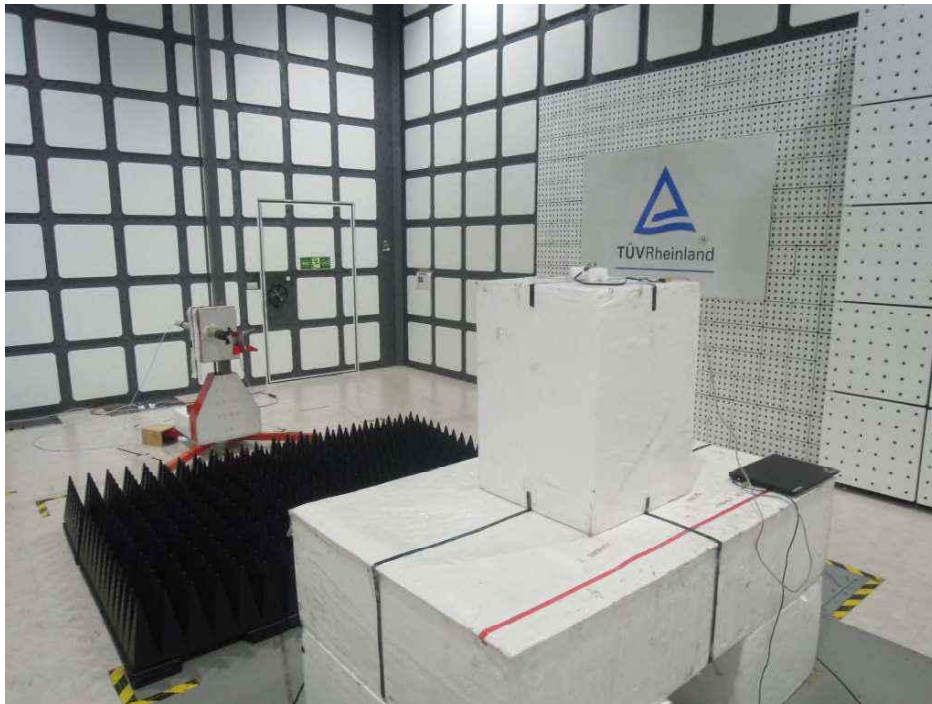

Photograph 5: Set-up for Spurious Emissions (Back View 3) – Left Ear



Photograph 6: Set-up for Spurious Emissions (Back View 4) – Left Ear

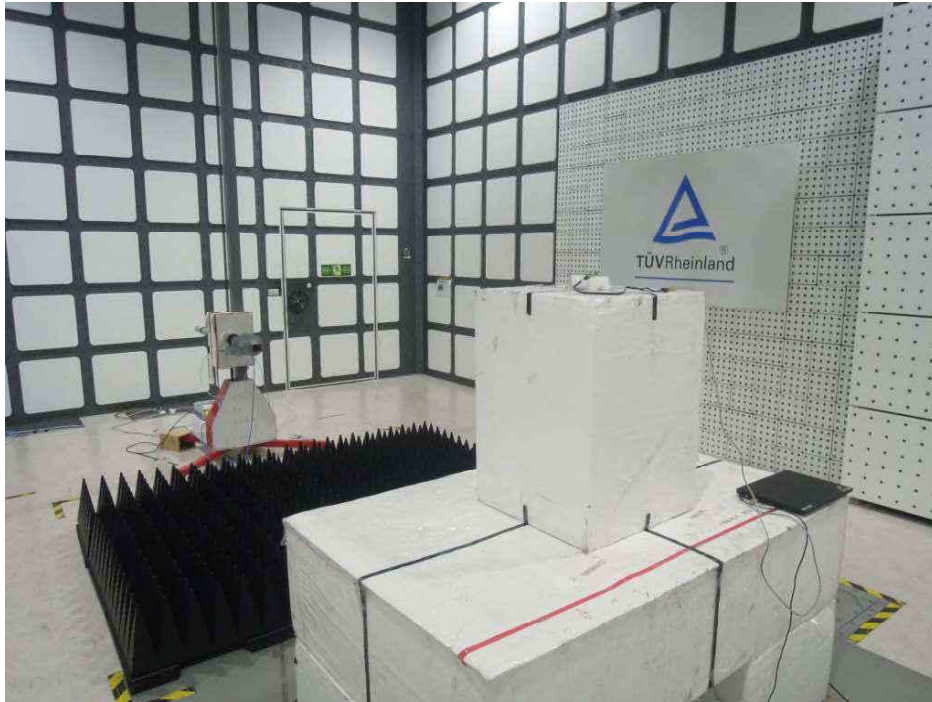

Photograph 7: Set-up for Spurious Emissions (Front View 1) – Right Ear



Photograph 8: Set-up for Spurious Emissions (Front View 2) – Right Ear



Photograph 9: Set-up for Spurious Emissions (Back View 1) – Right Ear



Photograph 10: Set-up for Spurious Emissions (Back View 2) – Right Ear

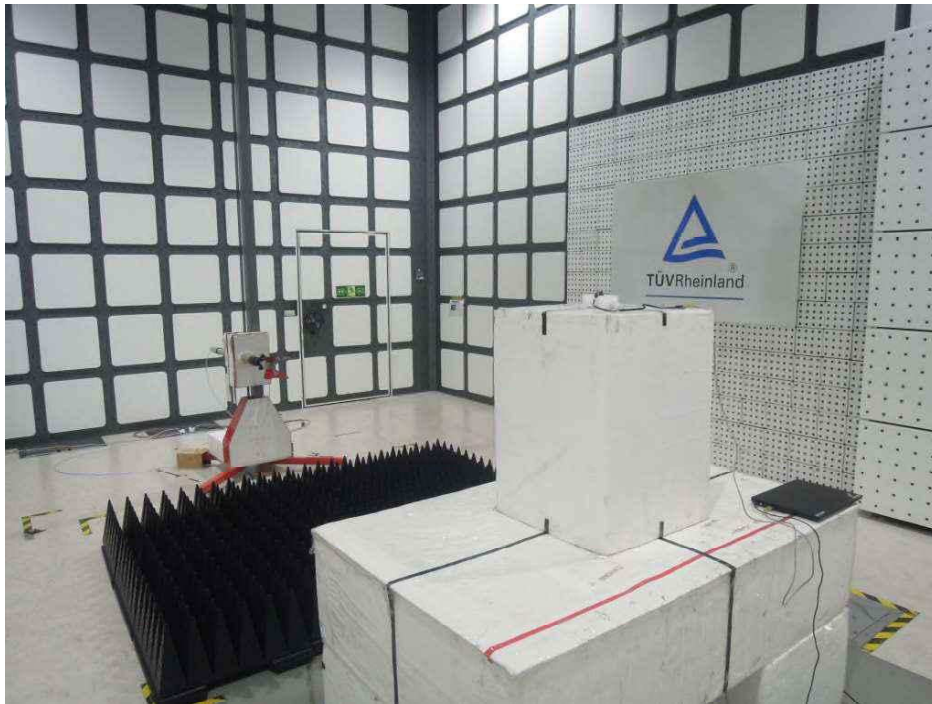

Photograph 11: Set-up for Spurious Emissions (Back View 3) – Right Ear

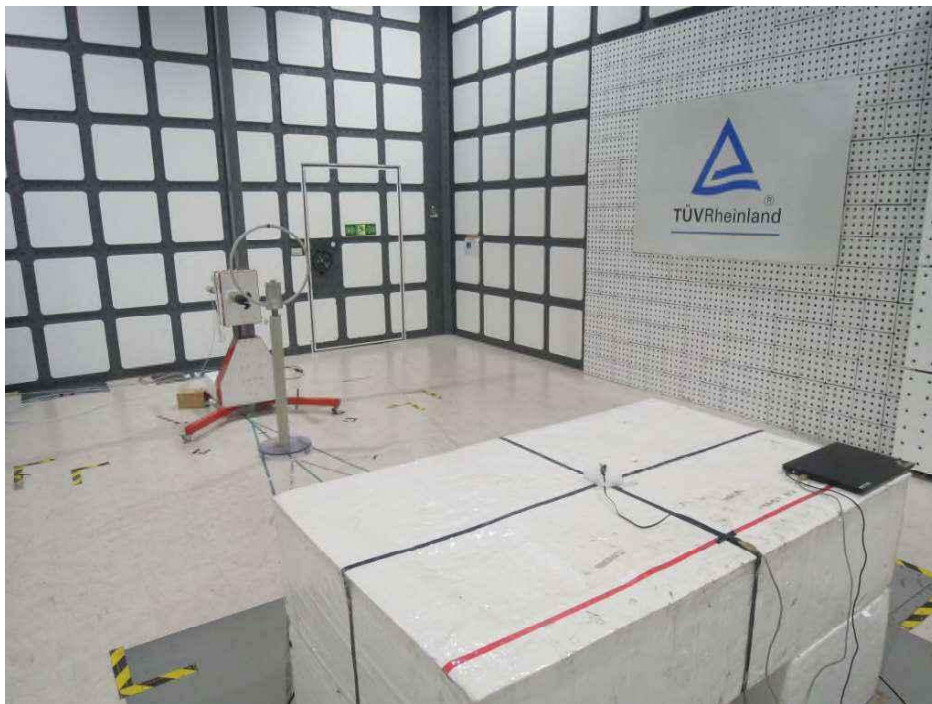

Photograph 12: Set-up for Spurious Emissions (Back View 4) – Right Ear



Photograph 13: Set-up for Conducted testing



Photograph 14: Set-up for Conducted testing – Left Ear

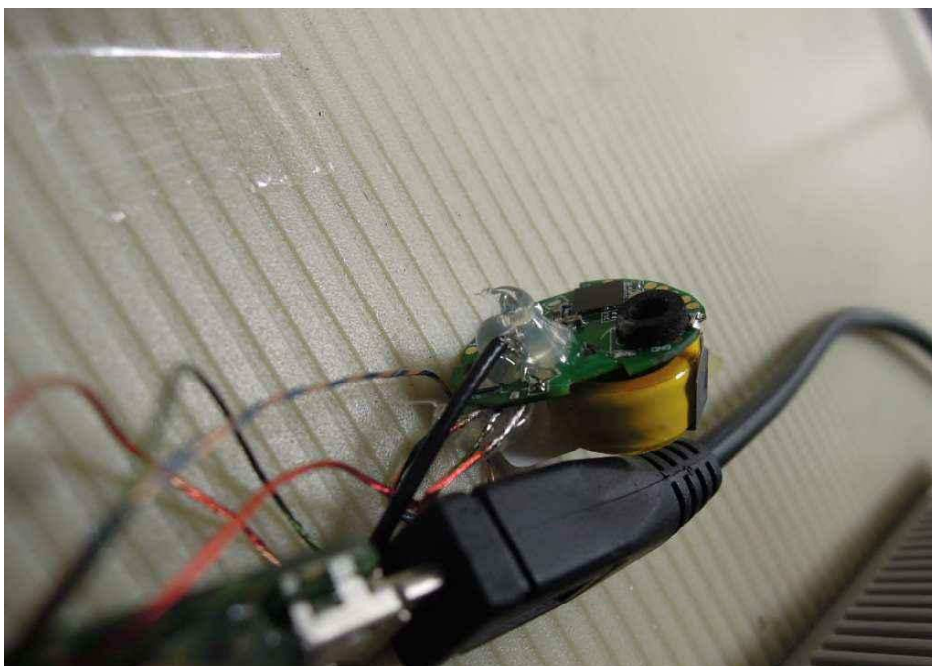

Photograph 15: Set-up for Conducted testing – Right Ear

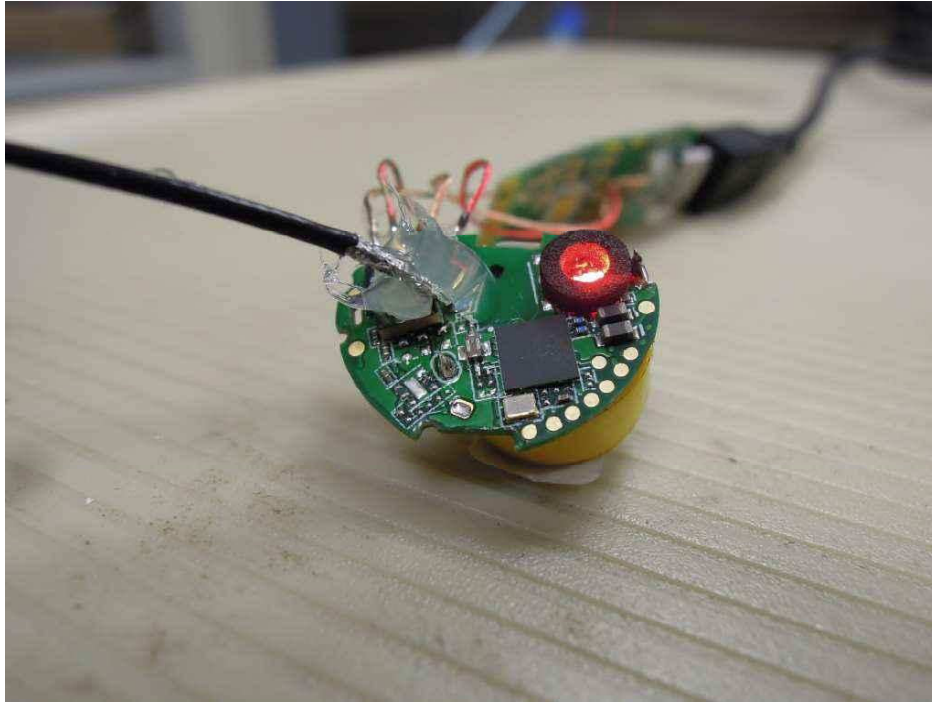

Photograph 16: Set-up for Mains Conducted testing (Back View)



Photograph 17: Set-up for Mains Conducted testing (Front View)



8. List of Tables

Table 1: Applied Standard and Test Levels	5
Table 2: List of Test and Measurement Equipment	7
Table 3: Emission Measurement Uncertainty.....	8
Table 4: Basic Information of EUT	9
Table 5: Technical Specification of EUT	9
Table 6: Frequency hopping information	10
Table 7: Test result of Maximum conducted output power, GFSK modulation – Left Ear	17
Table 8: Test result of Maximum conducted output power, 8DPSK modulation – Left Ear	17
Table 9: Test result of Maximum conducted output power, GFSK modulation – Right Ear.....	18
Table 10: Test result of Maximum conducted output power, 8DPSK modulation – Right Ear.....	18
Table 11: Test result of 20dB Bandwidth, GFSK modulation – Left Ear	19
Table 12: Test result of 20dB Bandwidth, 8DPSK modulation – Left Ear	19
Table 13: Test result of 20dB Bandwidth, GFSK modulation – Right Ear.....	23
Table 14: Test result of 20dB Bandwidth, 8DPSK modulation – Right Ear.....	23
Table 15: Test result of Frequency Separation (GFSK) – Left Ear	43
Table 16: Test result of Frequency Separation (8DPSK) – Left Ear	43
Table 17: Test result of Frequency Separation (GFSK) – Right Ear.....	45
Table 18: Test result of Frequency Separation (8DPSK) – Right Ear.....	45
Table 19: Test result of Number of hopping frequency – Left Ear	47
Table 20: Test result of Number of hopping frequency – Right Ear.....	47
Table 21: Test result of Time of Occupancy – Left Ear	52
Table 22: Test result of Time of Occupancy – Right Ear	55

9. List of Photographs

Photograph 1: Set-up for Spurious Emissions (Front View 1) – Left Ear	60
Photograph 2: Set-up for Spurious Emissions (Front View 2) – Left Ear	60
Photograph 3: Set-up for Spurious Emissions (Back View 1) – Left Ear	61
Photograph 4: Set-up for Spurious Emissions (Back View 2) – Left Ear	62
Photograph 5: Set-up for Spurious Emissions (Back View 3) – Left Ear	62
Photograph 6: Set-up for Spurious Emissions (Back View 4) – Left Ear	63
Photograph 7: Set-up for Spurious Emissions (Front View 1) – Right Ear	63
Photograph 8: Set-up for Spurious Emissions (Front View 2) – Right Ear	64
Photograph 9: Set-up for Spurious Emissions (Back View 1) – Right Ear.....	64
Photograph 10: Set-up for Spurious Emissions (Back View 2) – Right Ear.....	65
Photograph 11: Set-up for Spurious Emissions (Back View 3) – Right Ear.....	65
Photograph 12: Set-up for Spurious Emissions (Back View 4) – Right Ear.....	66
Photograph 13: Set-up for Conducted testing	67
Photograph 14: Set-up for Conducted testing – Left Ear	67
Photograph 15: Set-up for Conducted testing – Right Ear	68
Photograph 16: Set-up for Mains Conducted testing (Back View).....	68
Photograph 17: Set-up for Mains Conducted testing (Front View).....	69