

# FCC TEST REPORT

According to

## FCC Rules and Regulations Part 15 Subpart B

Applicant	:	OASIS Est. for Electronic Technologies
Address	:	P.O.Box 950615, Amman 11195 Jordan
Equipment	:	PC System
Model No.	:	SAMsync Q9000+
FCC ID	:	UZQ-Q9000
Trade Name	:	SAMsync

Laboratory accreditation



- The test result refers exclusively to the test presented test model / sample.
- Without written approval of **Exclusive Certification Corp.** the test report shall not be reproduced except in full.

**Contents**

**1. Test Configuration of Equipment under Test..... 4**

    1.1. Manufacture..... 4

    1.2. Feature of Equipment under Test ..... 4

    1.3. Test Manner ..... 4

    1.4. Description of Test System ..... 5

    1.5. Connection Diagram of Test System ..... 6

    1.6. General Information of Test ..... 7

    1.7. Measurement Uncertainty ..... 7

    1.8. History of this test report..... 8

**2. Test of Conducted Emission ..... 9**

    2.1. Test Limit..... 9

    2.2. Test Procedures..... 9

    2.3. Typical test Setup ..... 10

    2.4. Measurement Equipment ..... 10

    2.5. Test Result and Data ..... 11

    2.6. Test Photographs..... 15

**3. Test of Radiated Emission..... 16**

    3.1. Test Limit..... 16

    3.2. Test Procedures..... 16

    3.3. Typical test Setup ..... 17

    3.4. Measurement equipment..... 17

    3.5. Test Result and Data ..... 18

    3.6. Test Photographs..... 30

**Appendix A. Photographs of EUT.....A1 ~ A8**

# CERTIFICATE OF COMPLIANCE

According to

## FCC Rules and Regulations Part 15 Subpart B

Applicant : OASIS Est. for Electronic Technologies

Address : P.O.Box 950615, Amman 11195 Jordan

Equipment : PC System

Model No. : SAMsync Q9000+

FCC ID : UZQ-Q9000

**I HEREBY CERTIFY THAT :**

The measurements shown in this test report were made in accordance with the procedures given in **ANSI C63.4** The equipment was **passed** the test performed according to

**FCC Rules and Regulations Part 15 Subpart B.**

Testing was carried out on Oct. 07, 2008 at **Exclusive Certification Corp.**

Signature



Anson Chou

EMC/RF B.U. Vice General Manager

## 1. Test Configuration of Equipment under Test

### 1.1. Manufacture

OASIS Est. for Electronic Technologies  
P.O.Box 950615, Amman 11195 Jordan

### 1.2. Feature of Equipment under Test

- Intel Core 2 Duo Processor – 3.16 GHz / 6 MB Cache/ 1333 MHz FSB
- Intel Original Desktop Board Q35JO
- 1 GB / 667 MHz DDR2 RAM Kingston \* 2
- 160 GB SATA Hard disk Drive 7200 rpm
- Super DVD/RW Drive
- 1 PCI Express x16 graphics connector
- 6 SATA Interfaces
- 6 High-Speed USB 2.0 ports
- Intel Graphics Media Accelerator (GMA) 3100 with Dynamic Video Memory Technology (DVMT 4.0) with up to 256 MB shared Graphics Memory.
- 2+2-channel audio subsystem using the RealTek ALC268 audio codec
- 10/100 Mbps LAN

### 1.3. Test Manner

- a. During testing, the interface cables and equipment positions were varied according to ANSI C63.4.
- b. The complete test system included remote workstation, Monitor, Mouse, Keyboard, USB 2.0 HDD, 1394 HDD, Earphone, Walkman, Flash Memory and EUT for EMI Test. The remote workstation included Notebook.
- c. The result of test modes as follow:
  - Mode 1. VGA: 2048 x 1536 60Hz, DVI: 1280 x 1024 60Hz
  - Mode 2. VGA: 1600 x 1200 75Hz, DVI: 1024 x 768 75Hz
- d. An executive program, WINFCC.EXE under WIN XP, which generates a complete line of continuously repeating “H” pattern was used as the test software.  
The program was executed as follows:
  1. Turn on the power of all equipment.
  2. The PC reads the test program from the hard disk drive and runs it.
  3. The PC sends “H” messages to the monitor, and the monitor displays “H” patterns on the screen.
  4. The PC sends “H” messages to the internal Hard Disk, and the Hard Disk reads and writes the message.
  5. Repeat the steps from 2 to 4.
- e. An executive program, ping.exe under WIN XP was executed to transmit and receive data to the remote workstation through LAN.
- f. An executive program, winthrax.exe under WIN XP was executed to read and write data from EUT.
- g. An executive program, Mediaplayer.exe under WIN XP was executed to play music.

#### 1.4. Description of Test System

Device	Manufacturer	Model No.	Description
Monitor	ViewSonic	P225f	Power Cable, Adapter Unshielding 1.8 m Data Cable, S-Video Shielding 1.35 m
LCD Monitor	BenQ	Q24W5	Power Cable, Adapter Unshielding 1.8 m Data Cable, DVI Shielding 1.35 m
Keyboard	Logitech	Y-BL49	Data Cable, USB Shielding 1.85 m
Mouse	IBM	MO28VO	Data Cable, USB Shielding 1.85 m
USB 2.0 HDD*3	Terasys	F-12UF	Power Cable, Adapter Unshielding 1.8 m Data Cable, USB Shielding 1.6 m
1394 HDD	Terasys	F-12UF	Power Cable, Adapter Unshielding 1.8 m Data Cable, 1394 Shielding 1.6 m
Earphone	MIC	MIC-4	Data Cable, Audio Shielding 1.35 m
Walkman	Panasonic	RQ-L8LT	Data Cable, Audio Shielding 1.35 m
Flash Memory	Transcend	JF-150	N/A
Notebook (remote workstation)	DELL	PP10L	Power Cable, Adapter Unshielding 1.8 m

##### Use Cable:

Cable	Quantity	Description
RJ45	1	Unshielding, 5.0m
Audio	2	Shielding, 1.35m

### 1.5. Connection Diagram of Test System

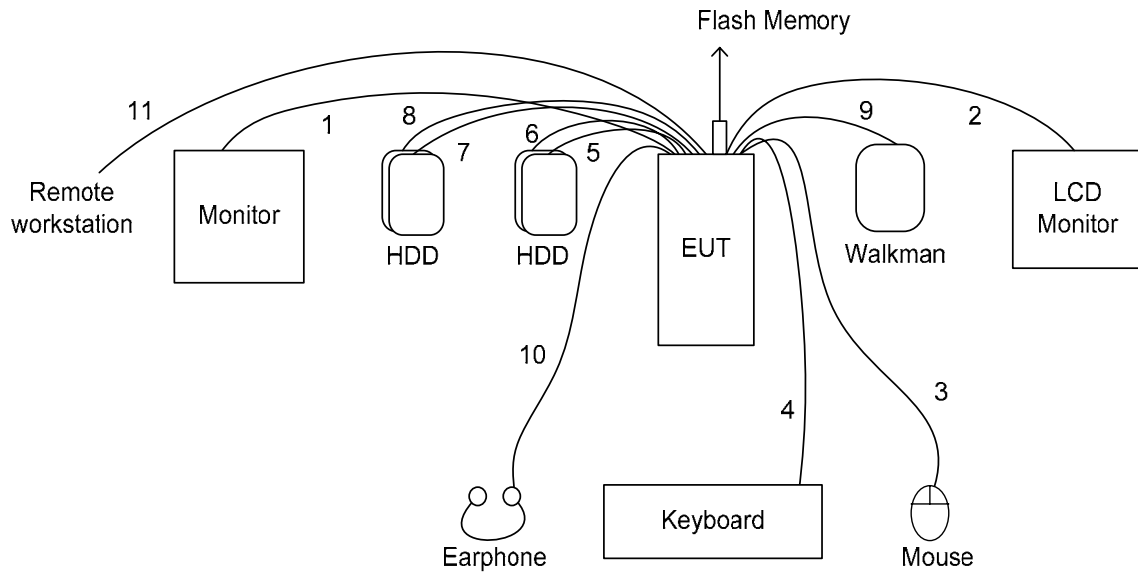

1. The VGA cable is connected from EUT to the Monitor.
2. The DVI cable is connected from EUT to the Monitor.
3. The USB cable is connected from EUT to the Keyboard.
4. The USB cable is connected from EUT to the Mouse.
5. The 1394 cable is connected from EUT to the 1394 HDD.
6. The USB cable is connected from EUT to the USB 2.0 HDD.
7. The USB cable is connected from EUT to the USB 2.0 HDD.
8. The USB cable is connected from EUT to the USB 2.0 HDD.
9. The Audio cable is connected from EUT to the Walkman.
10. The Audio cable is connected from EUT to the Earphone.
11. The RJ45 cable is connected from EUT to the remote workstation.

## 1.6. General Information of Test

Test Site :	Exclusive Certification Corp. 4F-2, No. 28, Lane 78, Xing-Ai Rd. Nei-hu, Taipei City 114 Taiwan R.O.C.
Test Site Location (OATS1-SD):	No.68-1, Shihbachongsi, shihding Township, Taipei City 223, Taiwan, R.O.C.
FCC Registration Number :	632249
IC Registration Number :	4934B-1
VCCI Registration Number :	T-338 for Telecommunication Test C-2188 for Conducted emission test R-1902 for Radiated emission test
Test Voltage:	AC 120V/ 60Hz
Test in Compliance with:	ANSI C63.4-2003 FCC Part 15 Subpart B
Frequency Range Investigated :	Conducted: from 150kHz to 30 MHz Radiation: from 30 MHz to 16,000 MHz
Test Distance :	The test distance of radiated emission below 1GHz from antenna to EUT is 10 M. The test distance of radiated emission above 1GHz from antenna to EUT is 3 M.

## 1.7. Measurement Uncertainty

Measurement Item	Measurement Frequency	Polarization	Uncertainty
Conducted Emission	9 kHz ~ 30 MHz	LINE / NEUTRAL	2.71 dB
Radiated Emission	30 MHz ~ 16GHz	Vertical	3.89 dB
		Horizontal	3.59 dB





## 2. Test of Conducted Emission

### 2.1. Test Limit

Conducted Emissions were measured from 150 kHz to 30 MHz with a bandwidth of 9 KHz on the 120 VAC power and return leads of the EUT according to the methods defined in ANSI C63.4-2003 Section 3.1. The EUT was placed on a nonmetallic stand in a shielded room 0.8 meters above the ground plane as shown in section 2.2. The interface cables and equipment positioning were varied within limits of reasonable applications to determine the position produced maximum conducted emissions.

Frequency (MHz)	Quasi Peak (dB $\mu$ V)	Average (dB $\mu$ V)
0.15 – 0.5	66-56*	56-46*
0.5 – 5.0	56	46
5.0 – 30.0	60	50

### 2.2. Test Procedures

- a. The EUT was placed 0.4 meter from the conducting wall of the shielding room was kept at least 80 centimeters from any other grounded conducting surface.
- b. Connect EUT to the power mains through a line impedance stabilization network (LISN).
- c. All the support units are connecting to the other LISN.
- d. The LISN provides 50 ohm coupling impedance for the measuring instrument.
- e. The FCC states that a 50 ohm, 50 micro-Henry LISN should be used.
- f. Both sides of AC line were checked for maximum conducted interference.
- g. The frequency range from 150 kHz to 30 MHz was searched.
- h. Set the test-receiver system to Peak Detect Function and Specified Bandwidth with Maximum Hold Mode.

### 2.3. Typical test Setup

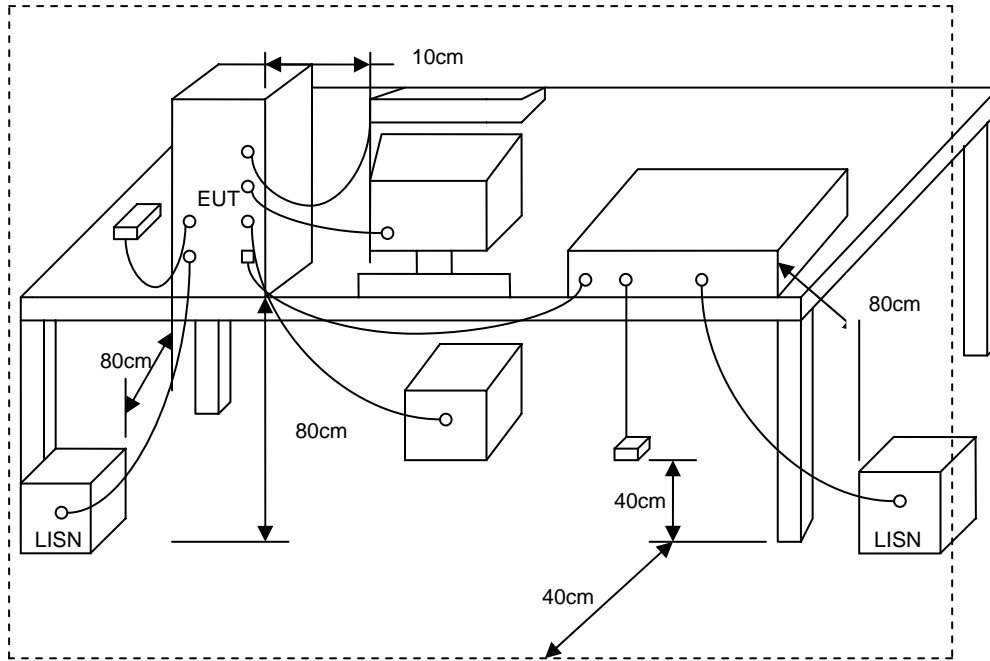

### 2.4. Measurement Equipment

Instrument	Manufacturer	Model No.	Serial No.	Calibration Date	Valid Date
EMI Receiver	SCHAFFNER	SCR-3501	437	2007/11/26	2008/11/25
LISN	MESS TEC	NNB-2/16Z	02/10191	2008/06/03	2009/06/02
LISN	ROLF HEINE	NNB-2/16Z	03/10058	2008/04/19	2009/04/18

## 2.5. Test Result and Data

### 2.5.1 Conducted Emission for Power Port Test Data

Power	: AC 120V	Pol/Phase	: LINE
Test Mode 1	: VGA: 2048 x 1536 60Hz,	Temperature	: 26°C
	: DVI: 1280 x 1024 60Hz	Humidity	: 53%

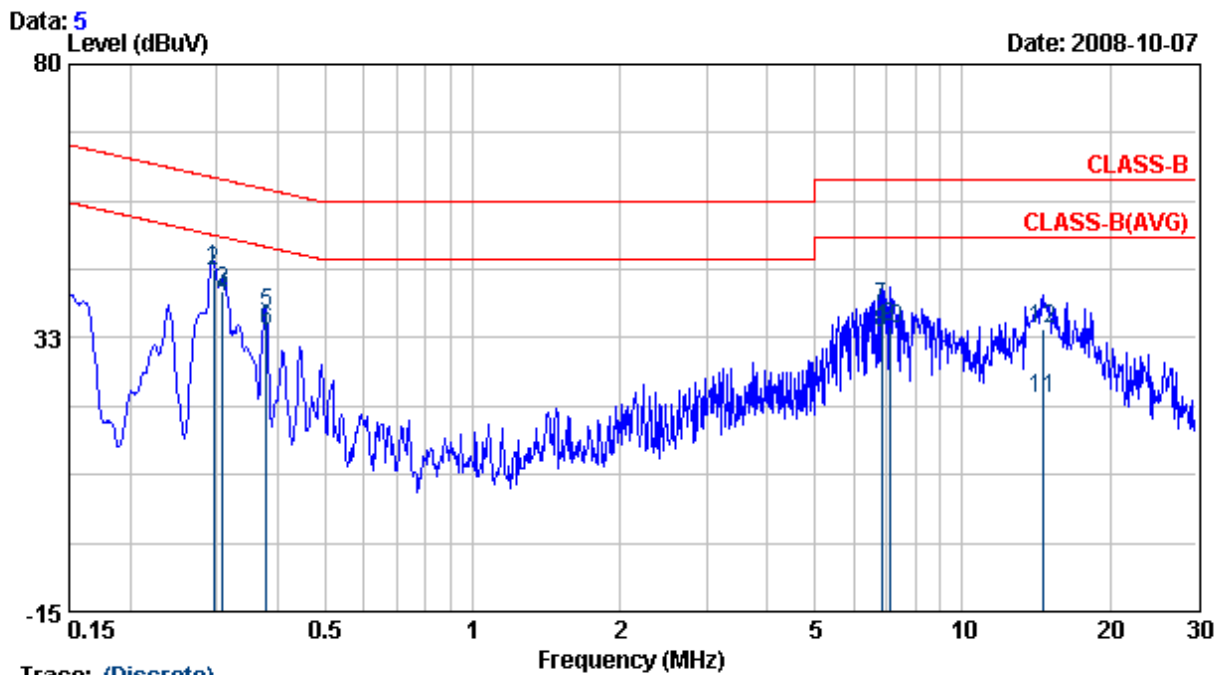

Trace: (Discrete)

Item	Freq	Read Value	Factor	Result	Limit	Margin	Remark
	MHz	dBuV	dB	dBuV	dBuV	dBuV	
1	0.30	44.28	0.12	44.40	60.37	-15.97	QP
2	0.30	43.93	0.12	44.05	50.37	-6.32	AVERAGE
3	0.31	40.49	0.12	40.60	60.02	-19.41	QP
4	0.31	39.44	0.12	39.56	50.02	-10.46	AVERAGE
5	0.38	36.75	0.11	36.86	58.31	-21.45	QP
6	0.38	33.48	0.11	33.59	48.31	-14.71	AVERAGE
7	6.84	37.40	0.35	37.75	60.00	-22.25	QP
8	6.84	32.86	0.35	33.21	50.00	-16.79	AVERAGE
9	7.08	34.07	0.35	34.42	50.00	-15.58	AVERAGE
10	7.08	33.87	0.35	34.22	50.00	-15.78	AVERAGE
11	14.60	21.59	0.44	22.03	50.00	-27.97	AVERAGE
12	14.60	33.67	0.44	34.12	60.00	-25.88	QP

Remarks: 1. Result = Read Value + Factor  
 2. Factor = LISN(ISN) Factor + Cable Loss

Power	: AC 120V	Pol/Phase	: NEUTRAL
Test Mode 1	: VGA: 2048 x 1536 60Hz,	Temperature	: 26°C
	: DVI: 1280 x 1024 60Hz	Humidity	: 53%

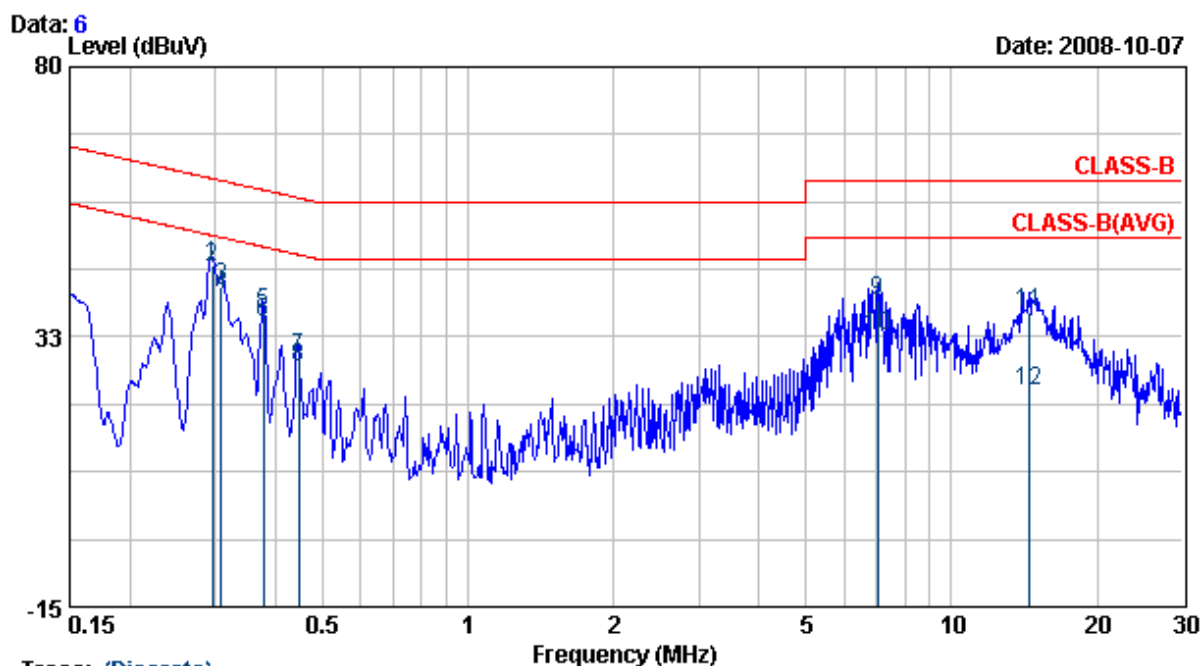

Trace: (Discrete)

Item	Freq	Read Value	Factor	Result	Limit	Margin	Remark
	MHz	dBuV	dB	dBuV	dBuV	dBuV	
1	0.30	45.06	0.14	45.20	60.37	-15.17	QP
2	0.30	44.65	0.14	44.79	50.37	-5.58	AVERAGE
3	0.31	41.19	0.14	41.33	60.02	-18.69	QP
4	0.31	39.72	0.14	39.86	50.02	-10.16	AVERAGE
5	0.38	36.55	0.14	36.68	58.34	-21.66	QP
6	0.38	34.90	0.14	35.04	48.34	-13.30	AVERAGE
7	0.45	28.68	0.14	28.83	56.92	-28.09	QP
8	0.45	27.07	0.14	27.21	46.92	-19.71	AVERAGE
9	7.02	38.42	0.37	38.79	60.00	-21.21	QP
10	7.02	32.38	0.37	32.75	50.00	-17.25	AVERAGE
11	14.44	36.29	0.46	36.75	60.00	-23.25	QP
12	14.44	22.47	0.46	22.93	50.00	-27.07	AVERAGE

Remarks: 1. Result = Read Value + Factor  
2. Factor = LISN(ISN) Factor + Cable Loss

Power	: AC 120V	Pol/Phase	: LINE
Test Mode 2	: VGA: 1600 x 1200 75Hz, DVI: 1024 x 768 75Hz	Temperature	: 26°C
		Humidity	: 53%

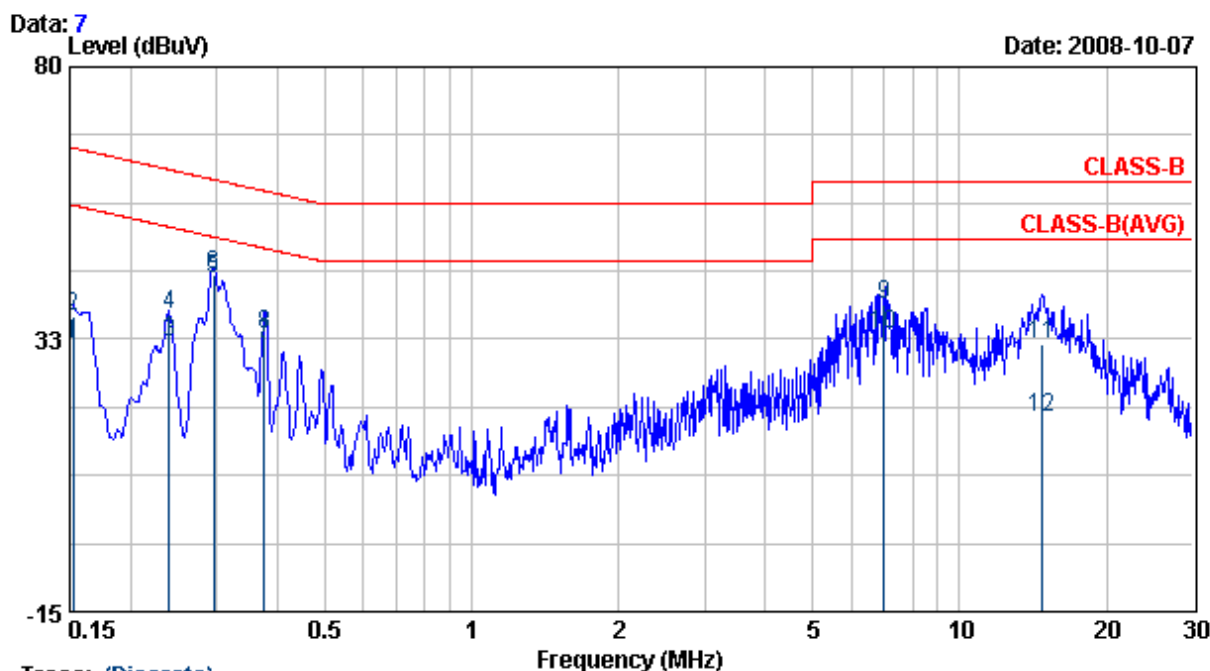

Trace: (Discrete)

Item	Freq MHz	Read Value dBuV	Factor dB	Result dBuV	Limit dBuV	Margin dBuV	Remark
1	0.15	31.63	0.11	31.74	55.87	-24.13	AVERAGE
2	0.15	36.24	0.11	36.35	65.87	-29.51	QP
3	0.24	32.03	0.11	32.14	52.08	-19.94	AVERAGE
4	0.24	36.56	0.11	36.67	62.08	-25.41	QP
5	0.30	42.98	0.12	43.09	50.37	-7.28	AVERAGE
6	0.30	43.55	0.12	43.67	60.37	-16.70	QP
7	0.38	31.65	0.11	31.76	48.39	-16.63	AVERAGE
8	0.38	33.34	0.11	33.45	58.39	-24.93	QP
9	7.02	38.28	0.35	38.63	60.00	-21.37	QP
10	7.02	33.03	0.35	33.38	50.00	-16.62	AVERAGE
11	14.71	31.19	0.45	31.63	60.00	-28.37	QP
12	14.71	18.42	0.45	18.87	50.00	-31.13	AVERAGE

Remarks: 1. Result = Read Value + Factor  
2. Factor = LISN(ISN) Factor + Cable Loss

Power	: AC 120V	Pol/Phase	: NEUTRAL
Test Mode 2	: VGA: 1600 x 1200 75Hz,	Temperature	: 26°C
	: DVI: 1024 x 768 75Hz	Humidity	: 53%

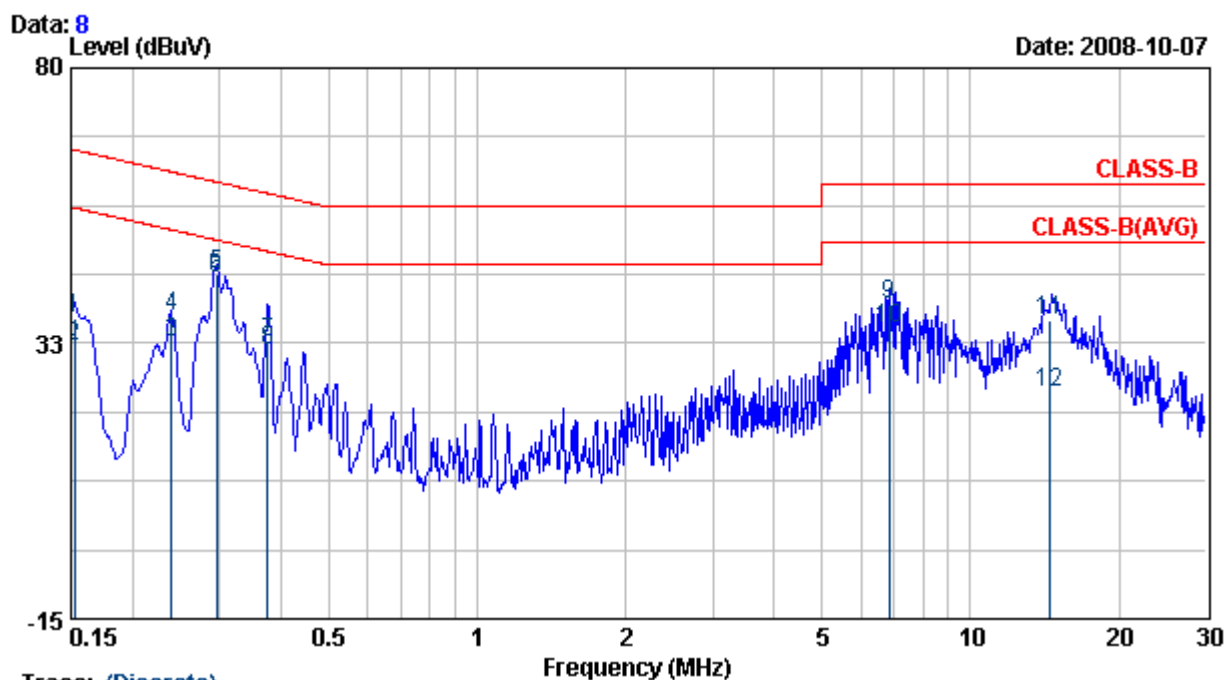

Trace: (Discrete)

Item	Freq MHz	Read Value dBuV	Factor dB	Result dBuV	Limit dBuV	Margin dBuV	Remark
1	0.15	36.51	0.14	36.65	65.87	-29.21	QP
2	0.15	31.97	0.14	32.10	55.87	-23.76	AVERAGE
3	0.24	32.58	0.14	32.71	52.08	-19.37	AVERAGE
4	0.24	37.14	0.14	37.27	62.08	-24.81	QP
5	0.30	44.29	0.14	44.42	60.37	-15.94	QP
6	0.30	43.68	0.14	43.82	50.37	-6.55	AVERAGE
7	0.38	32.38	0.14	32.52	58.39	-25.87	QP
8	0.38	31.11	0.14	31.24	48.39	-17.14	AVERAGE
9	6.85	38.84	0.36	39.21	60.00	-20.79	QP
10	6.85	34.77	0.36	35.13	50.00	-14.87	AVERAGE
11	14.53	36.00	0.47	36.47	60.00	-23.53	QP
12	14.53	23.56	0.47	24.02	50.00	-25.98	AVERAGE

Remarks: 1. Result = Read Value + Factor  
2. Factor = LISN(ISN) Factor + Cable Loss

Test engineer: Tom

## 2.6. Test Photographs

Front View



Rear View



### 3. Test of Radiated Emission

#### 3.1. Test Limit

Radiated emissions from 30 MHz to 16 GHz were measured according to the methods defines in ANSI C63.4-2003. The EUT was placed, 0.8 meter above the ground plane, as shown in section 5.6.3. The interface cables and equipment positions were varied within limits of reasonable applications to determine the positions producing maximum radiated emissions For unintentional device, according to § 15.109(a), except for Class A digital devices, the field strength of radiated emissions from unintentional radiators at a distance of 3 meters shall not exceed the following values:

Frequency (MHz)	Distance Meters	Radiated ( $\mu$ V / M)	Radiated (dB $\mu$ V/ M)
30-88	3	100	40.0
88-216	3	150	43.5
216-960	3	200	46.0
Above 960	3	500	54.0

#### 3.2. Test Procedures

- a. The EUT was placed on a Rota table top 0.8 meter above ground.
- b. The EUT was set 3/10 meters from the interference receiving antenna which was mounted on the top of a variable height antenna tower.
- c. The table was rotated 360 degrees to determine the position of the highest radiation.
- d. The antenna is a half wave dipole and its height is varied between one meter and four meters above ground to find the maximum value of the field strength both horizontal polarization and vertical polarization of the antenna are set to make the measurement.
- e. For each suspected emission the EUT was arranged to its worst case and then tune the antenna tower (from 1 M to 4 M) and turn table (from 0 degree to 360 degrees) to find the maximum reading.
- f. Set the test-receiver system to Peak Detect Function and specified bandwidth with Maximum Hold Mode.
- g. If the emission level of the EUT in peak mode was 6 dB lower than the limit specified, then testing will be stopped and peak values of EUT will be reported, otherwise, the emissions which do not have 6 dB margin will be repeated one by one using the quasi-peak method and reported.



### 3.3. Typical test Setup

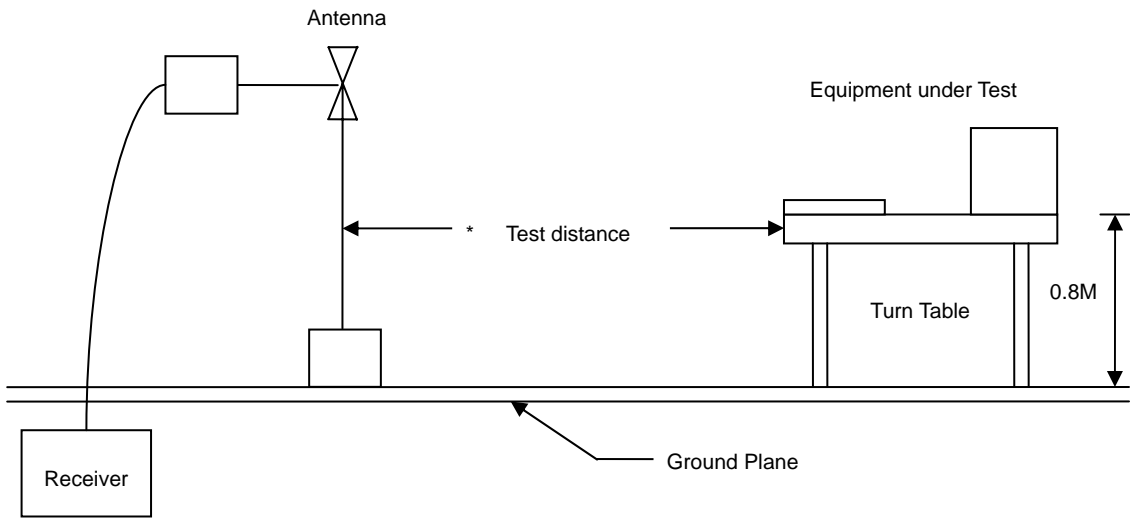

### 3.4. Measurement equipment

Instrument	Model No.	Manufacturer	Serial No.	Calibration Date	Valid Date
Bilog Antenna	CBL6112B	Schaffner	2840	2008/05/15	2009/05/14
Signal Generator	8648B	HP	3629U00612	2007/10/09	2008/10/08
Amplifier	8447D	Agilent	2944A10593	2008/05/26	2009/05/25
EMI Receiver	SCR-3501	SCHAFFNER	437	2007/11/26	2008/11/25
Spectrum	FSP40	R&S	100047	2008/02/22	2009/02/21
AC Power Converter	AFC-11005	APC	F103120008	N/A	N/A

### 3.5. Test Result and Data

Power	: AC 120V	Pol/Phase	: VERTICAL
Test Mode 1	: VGA: 2048 x 1536 60Hz	Temperature	: 25°C
	: DVI: 1280 x 1024 60Hz	Humidity	: 70%

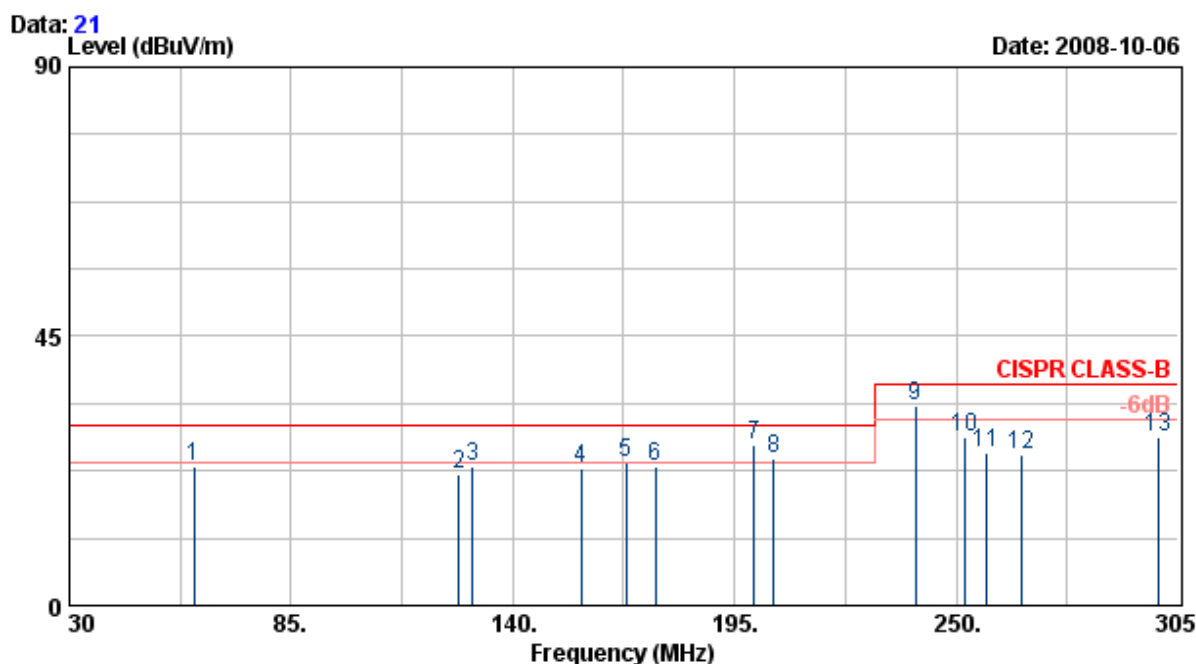

Item	Freq MHz	Read Value dBuV/m	Factor dB	Result dBuV/m	Limit dBuV/m	Margin dB	Remark	Ant Pos cm	Tab Pos Deg
1	60.80	44.11	-20.90	23.21	30.00	-6.79	Peak	100	360
2	126.53	36.84	-14.83	22.01	30.00	-7.99	Peak	100	360
3	130.10	38.14	-14.95	23.18	30.00	-6.82	Peak	100	360
4	157.05	38.75	-15.91	22.83	30.00	-7.17	Peak	100	360
5	168.05	40.06	-16.26	23.80	30.00	-6.20	Peak	100	360
6	175.45	39.68	-16.43	23.25	30.00	-6.75	Peak	100	360
7	199.80	43.27	-16.51	26.75	30.00	-3.25	QP	100	360
8	204.68	40.94	-16.35	24.59	30.00	-5.41	QP	100	360
9	240.00	47.37	-14.08	33.29	37.00	-3.71	QP	100	360
10	251.93	41.06	-12.80	28.26	37.00	-8.74	Peak	100	360
11	257.70	37.29	-11.74	25.54	37.00	-11.46	Peak	100	360
12	266.23	37.15	-11.99	25.16	37.00	-11.84	Peak	100	360
13	300.01	39.40	-11.30	28.10	37.00	-8.90	Peak	100	360

Remarks: 1. Result = Read Value + Factor  
2. Factor = Antenna factor + Cable loss - Amplifier factor

Power	: AC 120V	Pol/Phase	: VERTICAL
Test Mode 2	: VGA: 2048 x 1536 60Hz	Temperature	: 25°C
	: DVI: 1280 x 1024 60Hz	Humidity	: 70%

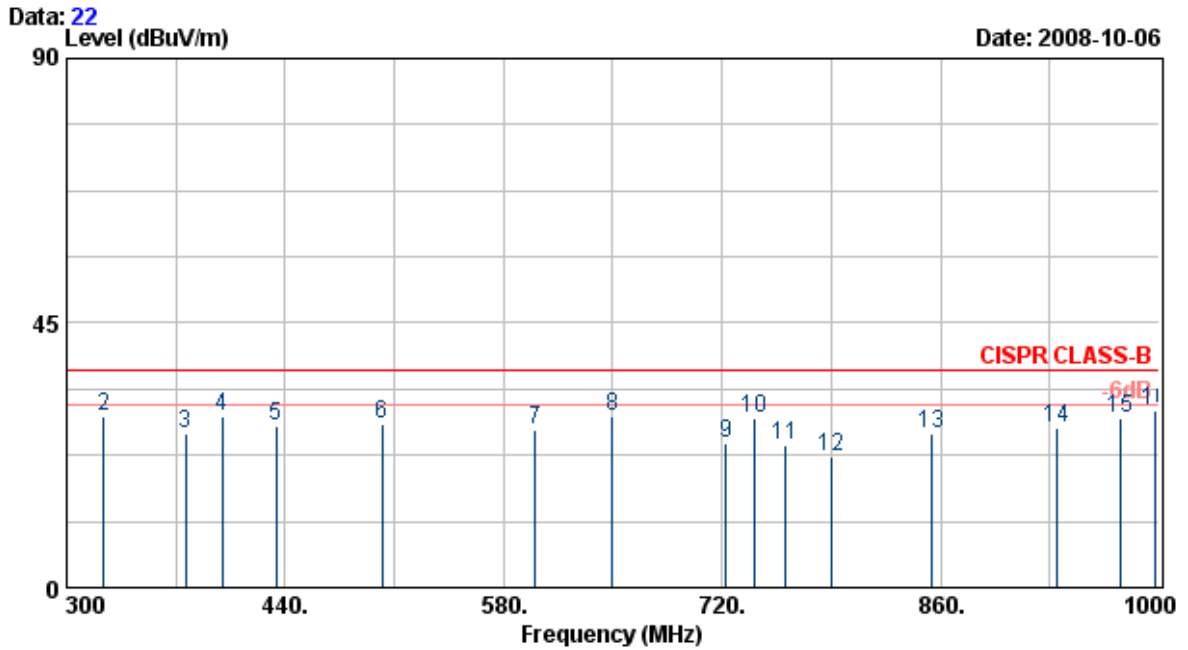

Item	Freq	Read Value	Factor	Result	Limit	Margin	Remark	Ant Pos	Tab Pos
	MHz	dBuV/m	dB	dBuV/m	dBuV/m	dB		cm	Deg
1	300.01	39.40	-11.30	28.10	37.00	-8.90	Peak	100	0
2	323.80	40.01	-10.80	29.21	37.00	-7.79	Peak	100	0
3	376.30	35.51	-9.38	26.13	37.00	-10.87	Peak	100	0
4	399.40	37.85	-8.62	29.23	37.00	-7.77	Peak	100	0
5	434.40	35.62	-8.29	27.33	37.00	-9.67	Peak	100	0
6	502.30	35.80	-7.91	27.90	37.00	-9.10	Peak	100	0
7	600.16	32.38	-5.60	26.78	37.00	-10.22	Peak	100	0
8	650.00	34.15	-5.00	29.15	37.00	-7.86	Peak	100	0
9	722.80	28.77	-4.38	24.40	37.00	-12.60	Peak	100	0
10	740.30	32.64	-3.97	28.67	37.00	-8.33	Peak	100	0
11	759.90	27.77	-3.58	24.18	37.00	-12.82	Peak	100	0
12	790.70	25.46	-3.06	22.40	37.00	-14.60	Peak	100	0
13	854.40	27.90	-1.68	26.23	37.00	-10.77	Peak	100	0
14	934.90	27.60	-0.52	27.08	37.00	-9.92	Peak	100	0
15	974.80	28.85	-0.03	28.83	37.00	-8.17	Peak	100	0
16	997.90	29.73	0.27	30.00	37.00	-7.00	Peak	100	0

Remarks: 1. Result = Read Value + Factor  
 2. Factor = Antenna factor + Cable loss - Amplifier factor

Power	: AC 120V	Pol/Phase	: HORIZONTAL
Test Mode 3	: VGA: 2048 x 1536 60Hz	Temperature	: 25°C
	: DVI: 1280 x 1024 60Hz	Humidity	: 70%

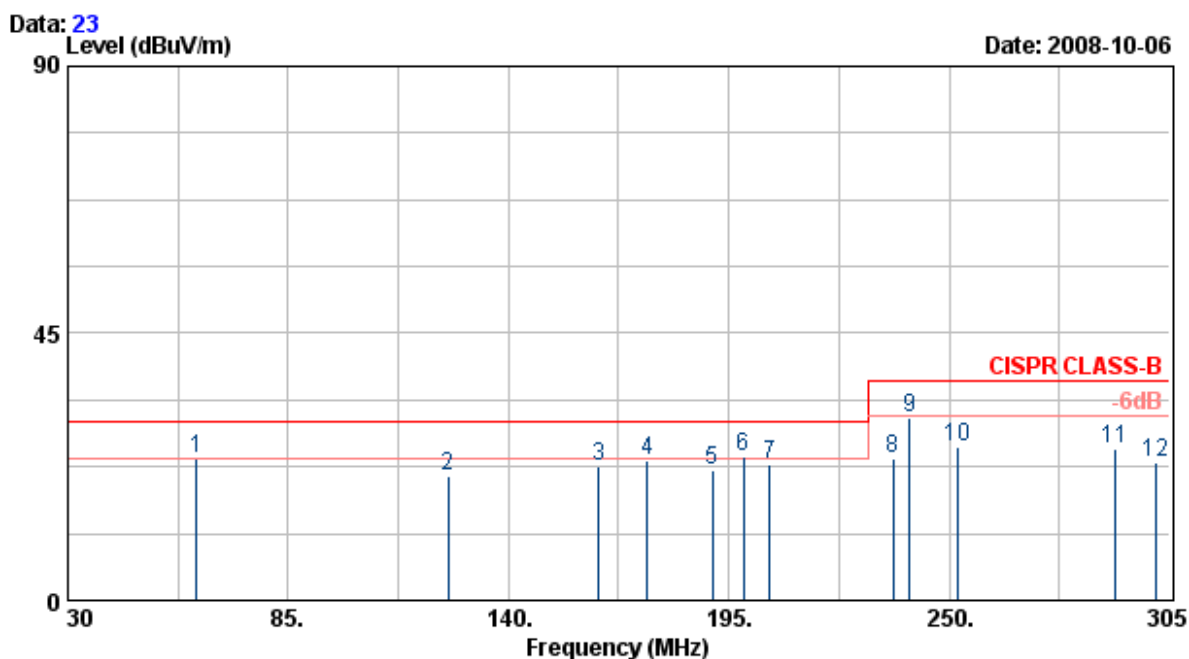

Item	Freq	Read Value	Factor	Result	Limit	Margin	Remark	Ant Pos	Tab Pos
	MHz	dBuV/m	dB	dBuV/m	dBuV/m	dB		cm	Deg
1	62.18	44.70	-20.94	23.76	30.00	-6.24	Peak	400	0
2	125.00	35.64	-14.78	20.87	30.00	-9.14	Peak	400	0
3	162.48	38.73	-16.01	22.72	30.00	-7.28	QP	400	0
4	174.59	39.85	-16.42	23.43	30.00	-6.57	Peak	400	0
5	190.84	38.86	-17.00	21.86	30.00	-8.14	Peak	400	0
6	198.62	40.77	-16.58	24.20	30.00	-5.80	QP	400	0
7	205.18	39.39	-16.33	23.06	30.00	-6.94	Peak	400	0
8	235.98	38.46	-14.58	23.89	37.00	-13.11	Peak	400	0
9	240.02	44.92	-14.08	30.84	37.00	-6.16	QP	400	0
10	251.93	38.50	-12.80	25.71	37.00	-11.29	Peak	400	0
11	291.25	37.14	-11.76	25.38	37.00	-11.62	Peak	400	0
12	301.43	34.51	-11.27	23.24	37.00	-13.76	Peak	400	0

Remarks: 1. Result = Read Value + Factor  
2. Factor = Antenna factor + Cable loss - Amplifier factor

Power	: AC 120V	Pol/Phase	: HORIZONTAL
Test Mode 4	: VGA: 2048 x 1536 60Hz	Temperature	: 25°C
	: DVI: 1280 x 1024 60Hz	Humidity	: 70%

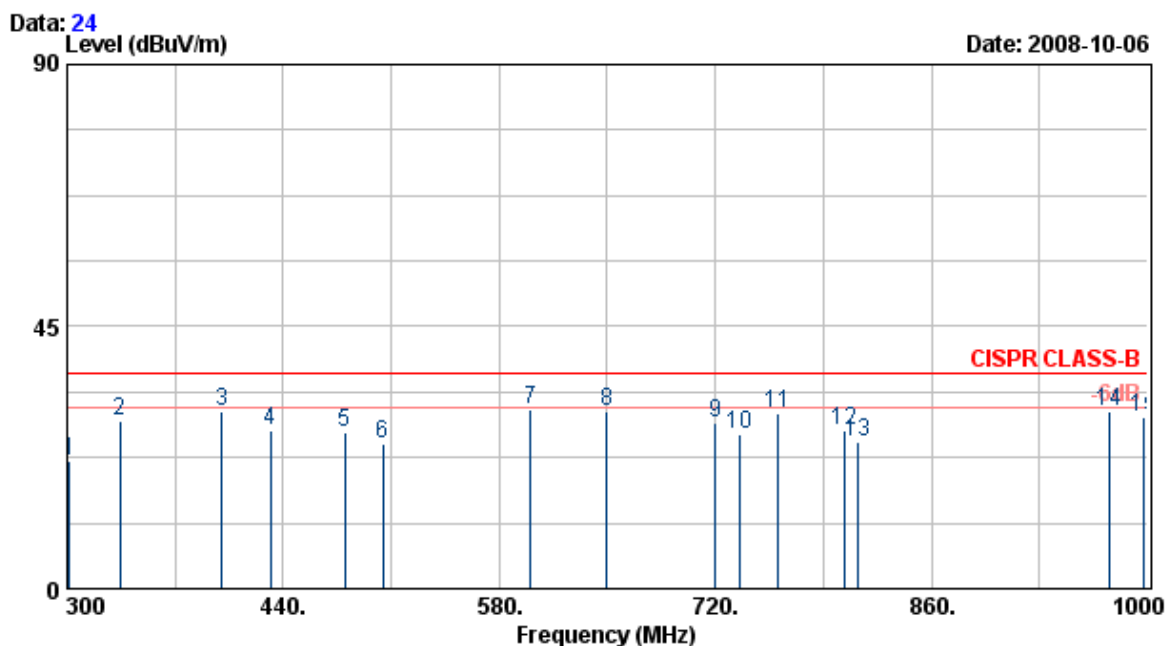

Item	Freq	Read Value	Factor	Result	Limit	Margin	Remark	Ant Pos	Tab Pos
	MHz	dBuV/m	dB	dBuV/m	dBuV/m	dB		cm	Deg
1	301.40	33.20	-11.27	21.93	37.00	-15.07	Peak	100	360
2	334.30	39.26	-10.58	28.68	37.00	-8.32	Peak	100	360
3	400.10	38.98	-8.60	30.38	37.00	-6.62	Peak	100	360
4	432.00	35.52	-8.31	27.20	37.00	-9.80	QP	100	360
5	480.01	34.96	-8.06	26.90	37.00	-10.10	Peak	100	360
6	504.40	32.82	-7.82	24.99	37.00	-12.01	Peak	100	360
7	600.14	36.32	-5.60	30.72	37.00	-6.28	Peak	100	360
8	650.00	35.43	-5.00	30.43	37.00	-6.57	Peak	100	360
9	719.99	32.92	-4.44	28.48	37.00	-8.52	QP	100	360
10	735.40	30.44	-4.09	26.36	37.00	-10.64	Peak	100	360
11	759.90	33.67	-3.58	30.09	37.00	-6.91	Peak	100	360
12	803.30	29.91	-2.82	27.08	37.00	-9.92	Peak	100	360
13	812.40	27.93	-2.61	25.32	37.00	-11.68	Peak	100	360
14	974.80	30.33	-0.03	30.31	37.00	-6.69	Peak	100	360
15	997.90	29.22	0.27	29.49	37.00	-7.51	Peak	100	360

Remarks: 1. Result = Read Value + Factor  
 2. Factor = Antenna factor + Cable loss - Amplifier factor

Power	: AC 120V	Pol/Phase	: VERTICAL
Test Mode 1	: VGA: 2048 x 1536 60Hz	Temperature	: 28°C
	: DVI: 1280 x 1024 60Hz	Humidity	: 72%

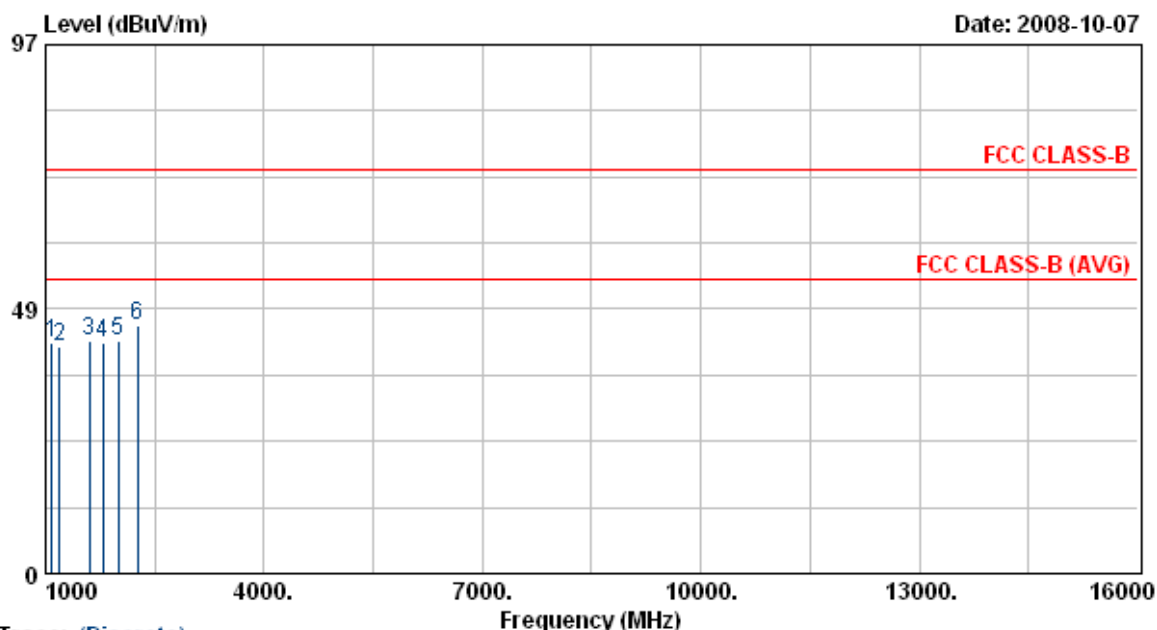

Trace: (Discrete)

Item	Freq	Read Value	Factor	Result	Limit	Margin	Remark	Ant Pos	Tab Pos
	MHz	dBuV/m	dB	dBuV/m	dBuV/m	dB		cm	Deg
1	1091.00	52.33	-9.89	42.44	74.00	-31.56	Peak	100	360
2	1188.50	50.92	-9.34	41.58	74.00	-32.42	Peak	100	360
3	1598.00	49.81	-7.07	42.74	74.00	-31.26	Peak	100	360
4	1793.00	48.22	-6.02	42.20	74.00	-31.80	Peak	100	360
5	2001.00	47.53	-4.90	42.63	74.00	-31.37	Peak	100	360
6	2261.00	49.33	-3.96	45.37	74.00	-28.63	Peak	100	360

Remarks: 1. Result = Read Value + Factor  
 2. Factor = Antenna factor + Cable loss - Amplifier factor

Power	: AC 120V	Pol/Phase	: HORIZONTAL
Test Mode 1	: VGA: 2048 x 1536 60Hz	Temperature	: 28°C
	: DVI: 1280 x 1024 60Hz	Humidity	: 72%

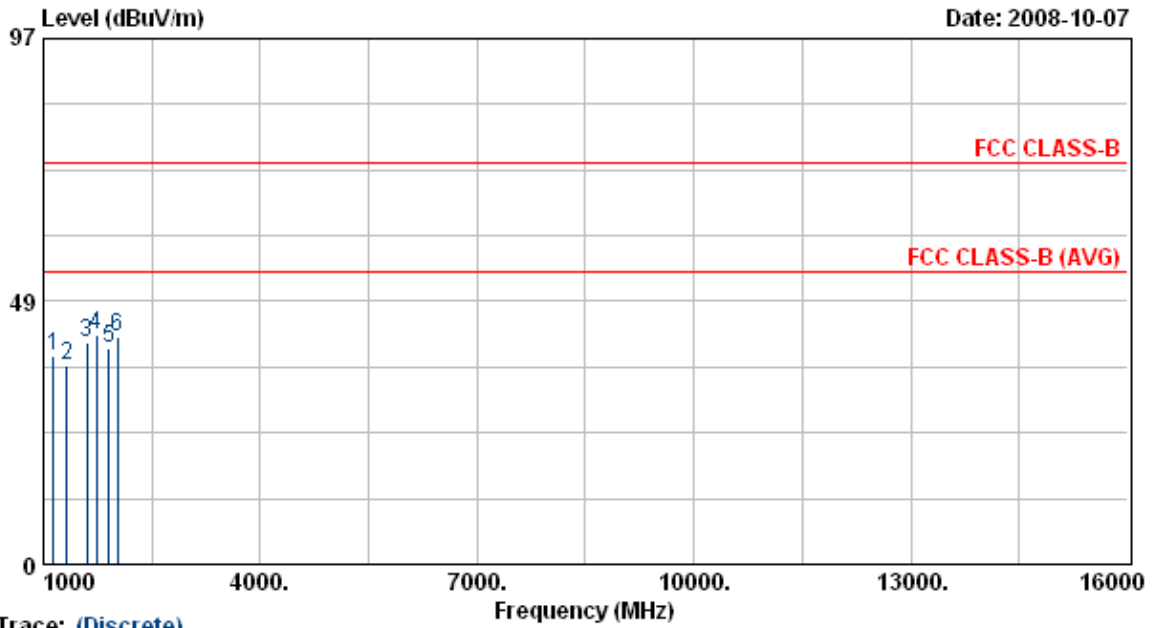

Trace: (Discrete)

Item	Freq	Read Value	Factor	Result	Limit	Margin	Remark	Ant Pos	Tab Pos
	MHz	dBuV/m	dB	dBuV/m	dBuV/m	dB		cm	Deg
1	1143.00	48.14	-9.60	38.54	74.00	-35.46	Peak	100	0
2	1318.50	45.33	-8.62	36.71	74.00	-37.29	Peak	100	0
3	1598.00	47.82	-7.07	40.75	74.00	-33.25	Peak	100	0
4	1728.00	48.53	-6.37	42.16	74.00	-31.84	Peak	100	0
5	1903.50	45.33	-5.42	39.91	74.00	-34.09	Peak	100	0
6	2020.50	46.93	-4.83	42.10	74.00	-31.90	Peak	100	0

Remarks: 1. Result = Read Value + Factor  
 2. Factor = Antenna factor + Cable loss - Amplifier factor

Power	: AC 120V	Pol/Phase	: VERTICAL
Test Mode 2	: VGA: 1600 x 1200 75Hz	Temperature	: 25°C
	: DVI: 1024 x 768 75Hz	Humidity	: 70%

Data: 29

Level (dBuV/m)

Date: 2008-10-06

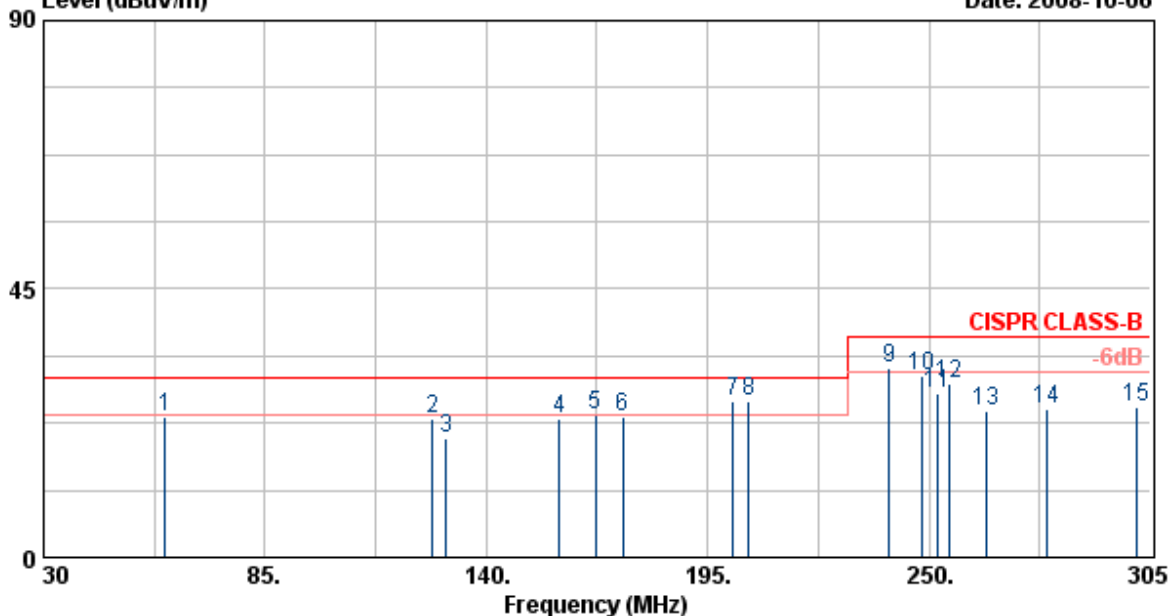

Item	Freq MHz	Read Value dBuV/m	Factor dB	Result dBuV/m	Limit dBuV/m	Margin dB	Remark	Ant Pos cm	Tab Pos Deg
1	60.25	44.33	-20.89	23.45	30.00	-6.55	Peak	100	0
2	126.53	38.04	-14.83	23.21	30.00	-6.79	Peak	100	0
3	130.10	34.80	-14.95	19.84	30.00	-10.16	Peak	100	0
4	158.15	39.02	-15.91	23.11	30.00	-6.89	Peak	100	0
5	167.23	40.19	-16.23	23.97	30.00	-6.03	Peak	100	0
6	173.83	39.95	-16.41	23.55	30.00	-6.45	Peak	100	0
7	201.44	42.65	-16.45	26.20	30.00	-3.80	QP	100	0
8	205.18	42.38	-16.33	26.05	30.00	-3.95	QP	100	0
9	240.03	45.88	-14.08	31.80	37.00	-5.20	QP	100	0
10	248.35	43.69	-13.30	30.38	37.00	-6.62	Peak	100	0
11	251.93	40.33	-12.80	27.53	37.00	-9.47	Peak	100	0
12	255.23	41.34	-12.19	29.14	37.00	-7.86	Peak	100	0
13	264.30	36.30	-11.78	24.52	37.00	-12.48	Peak	100	0
14	279.43	37.23	-12.27	24.96	37.00	-12.04	Peak	100	0
15	301.43	36.49	-11.27	25.22	37.00	-11.78	Peak	100	0

Remarks: 1. Result = Read Value + Factor  
 2. Factor = Antenna factor + Cable loss - Amplifier factor



Power	: AC 120V	Pol/Phase	: VERTICAL
Test Mode 2	: VGA: 1600 x 1200 75Hz	Temperature	: 25°C
	: DVI: 1024 x 768 75Hz	Humidity	: 70%

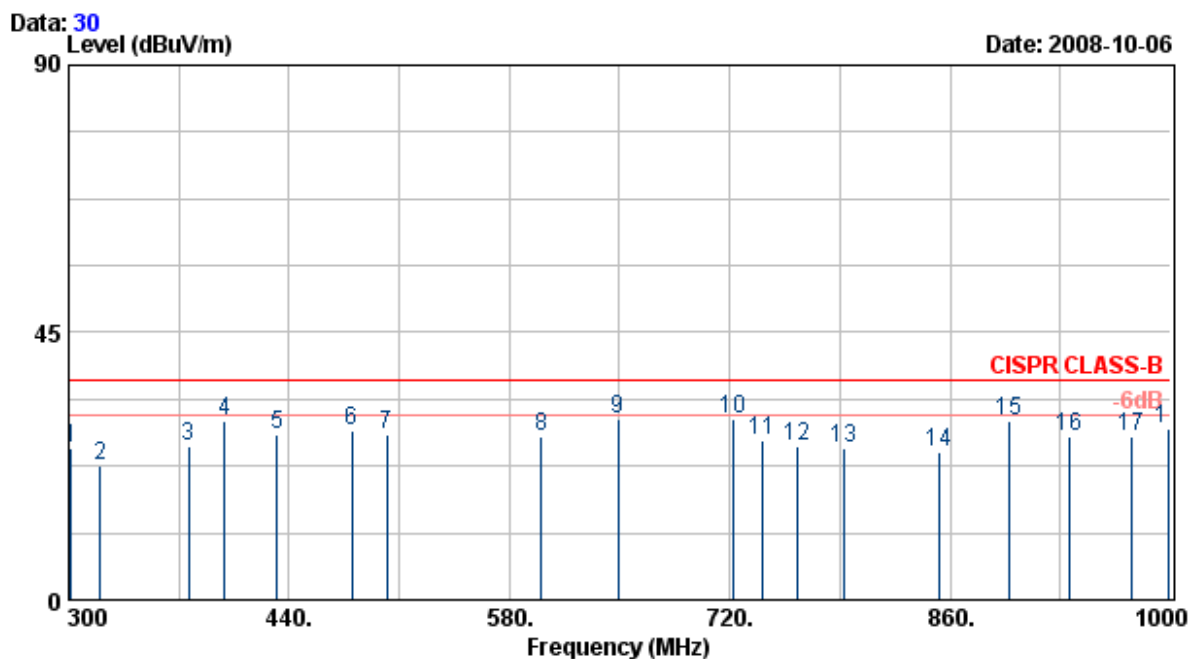

Item	Freq	Read Value	Factor	Result	Limit	Margin	Remark	Ant Pos	Tab Pos
	MHz	dBuV/m	dB	dBuV/m	dBuV/m	dB		cm	Deg
1	301.40	36.94	-11.27	25.67	37.00	-11.33	Peak	100	360
2	320.30	33.36	-10.87	22.49	37.00	-14.51	Peak	100	360
3	376.30	35.21	-9.38	25.83	37.00	-11.17	Peak	100	360
4	398.99	38.74	-8.63	30.11	37.00	-6.89	Peak	100	360
5	432.30	36.25	-8.31	27.95	37.00	-9.05	Peak	100	360
6	480.16	36.65	-8.06	28.59	37.00	-8.41	Peak	100	360
7	502.30	35.83	-7.91	27.93	37.00	-9.07	Peak	100	360
8	600.16	33.03	-5.60	27.43	37.00	-9.57	Peak	100	360
9	649.30	35.50	-5.01	30.49	37.00	-6.51	Peak	100	360
10	722.80	34.82	-4.38	30.45	37.00	-6.55	Peak	100	360
11	740.30	30.71	-3.97	26.74	37.00	-10.26	Peak	100	360
12	763.40	29.25	-3.52	25.73	37.00	-11.27	Peak	100	360
13	792.80	28.63	-3.02	25.60	37.00	-11.40	Peak	100	360
14	853.00	26.69	-1.70	24.99	37.00	-12.01	Peak	100	360
15	897.80	30.99	-0.94	30.05	37.00	-6.95	Peak	100	360
16	936.30	28.12	-0.50	27.62	37.00	-9.38	Peak	100	360
17	974.80	27.41	-0.03	27.39	37.00	-9.61	Peak	100	360
18	999.30	28.40	0.29	28.69	37.00	-8.31	Peak	100	360

Remarks: 1. Result = Read Value + Factor  
2. Factor = Antenna factor + Cable loss - Amplifier factor

Power	: AC 120V	Pol/Phase	: HORIZONTAL
Test Mode 2	: VGA: 1600 x 1200 75Hz	Temperature	: 25°C
	: DVI: 1024 x 768 75Hz	Humidity	: 70%

Data: 31

Level (dBuV/m)

Date: 2008-10-07

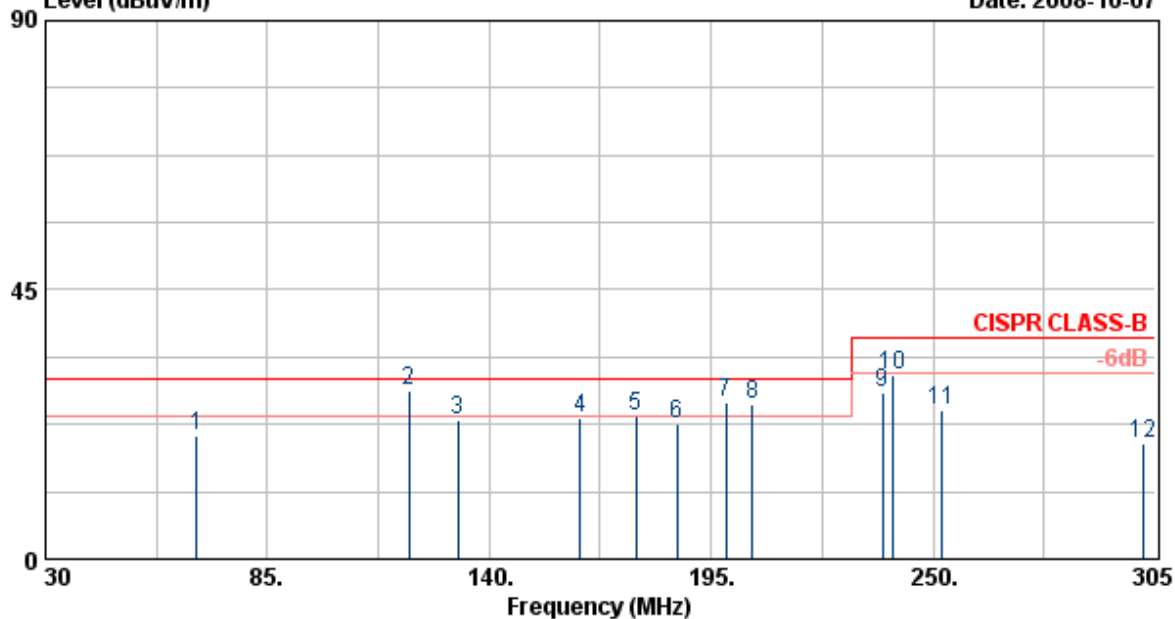

Item	Freq MHz	Read Value dBuV/m	Factor dB	Result dBuV/m	Limit dBuV/m	Margin dB	Remark	Ant Pos cm	Tab Pos Deg
1	67.40	41.74	-21.09	20.65	30.00	-9.35	Peak	400	0
2	120.01	42.59	-14.60	27.99	30.00	-2.01	QP	400	280
3	132.30	38.42	-15.03	23.39	30.00	-6.61	Peak	400	0
4	162.55	39.55	-16.01	23.54	30.00	-6.46	Peak	400	0
5	176.30	40.39	-16.44	23.94	30.00	-6.06	Peak	400	0
6	186.49	39.36	-16.86	22.51	30.00	-7.49	Peak	400	0
7	198.59	42.87	-16.58	26.29	30.00	-3.71	QP	400	0
8	205.18	42.09	-16.33	25.76	30.00	-4.24	QP	400	0
9	237.35	42.35	-14.41	27.94	37.00	-9.06	Peak	400	0
10	240.02	44.89	-14.08	30.81	37.00	-6.19	QP	400	0
11	251.93	37.58	-12.80	24.79	37.00	-12.21	Peak	400	0
12	301.98	30.41	-11.26	19.16	37.00	-17.84	Peak	400	0

Remarks: 1. Result = Read Value + Factor  
 2. Factor = Antenna factor + Cable loss - Amplifier factor

Power	: AC 120V	Pol/Phase	: HORIZONTAL
Test Mode 2	: VGA: 1600 x 1200 75Hz	Temperature	: 25°C
	: DVI: 1024 x 768 75Hz	Humidity	: 70%

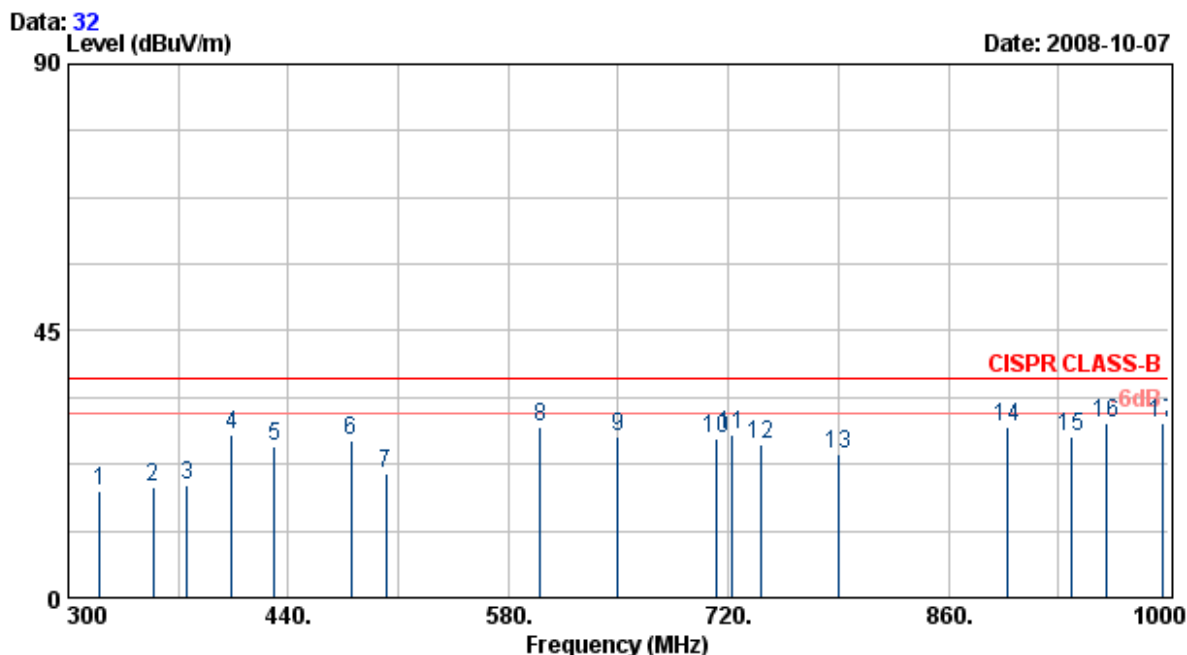

Item	Freq	Read Value	Factor	Result	Limit	Margin	Remark	Ant Pos	Tab Pos
	MHz	dBuV/m	dB	dBuV/m	dBuV/m	dB		cm	Deg
1	320.30	29.04	-10.87	18.16	37.00	-18.84	Peak	100	360
2	353.90	28.75	-10.12	18.63	37.00	-18.37	Peak	100	360
3	375.60	28.36	-9.41	18.95	37.00	-18.05	Peak	100	360
4	404.30	36.03	-8.56	27.47	37.00	-9.53	Peak	100	360
5	430.90	33.73	-8.32	25.41	37.00	-11.59	Peak	100	360
6	480.10	34.65	-8.06	26.59	37.00	-10.41	Peak	100	360
7	502.30	28.77	-7.91	20.86	37.00	-16.14	Peak	100	360
8	600.16	34.48	-5.60	28.88	37.00	-8.12	Peak	100	360
9	649.75	32.20	-5.00	27.20	37.00	-9.80	Peak	100	360
10	712.30	31.58	-4.62	26.96	37.00	-10.04	Peak	100	360
11	722.80	31.84	-4.38	27.47	37.00	-9.54	Peak	100	360
12	740.30	29.96	-3.97	25.99	37.00	-11.01	Peak	100	360
13	790.00	27.22	-3.07	24.15	37.00	-12.85	Peak	100	360
14	897.80	29.59	-0.94	28.65	37.00	-8.35	Peak	100	360
15	937.70	27.61	-0.49	27.13	37.00	-9.87	Peak	100	360
16	960.52	29.68	-0.21	29.47	37.00	-7.53	Peak	100	360
17	995.80	29.11	0.25	29.36	37.00	-7.64	Peak	100	360

Remarks: 1. Result = Read Value + Factor  
2. Factor = Antenna factor + Cable loss - Amplifier factor

Power	: AC 120V	Pol/Phase	: VERTICAL
Test Mode 2	: VGA: 1600 x 1200 75Hz	Temperature	: 28°C
	: DVI: 1024 x 768 75Hz	Humidity	: 72%

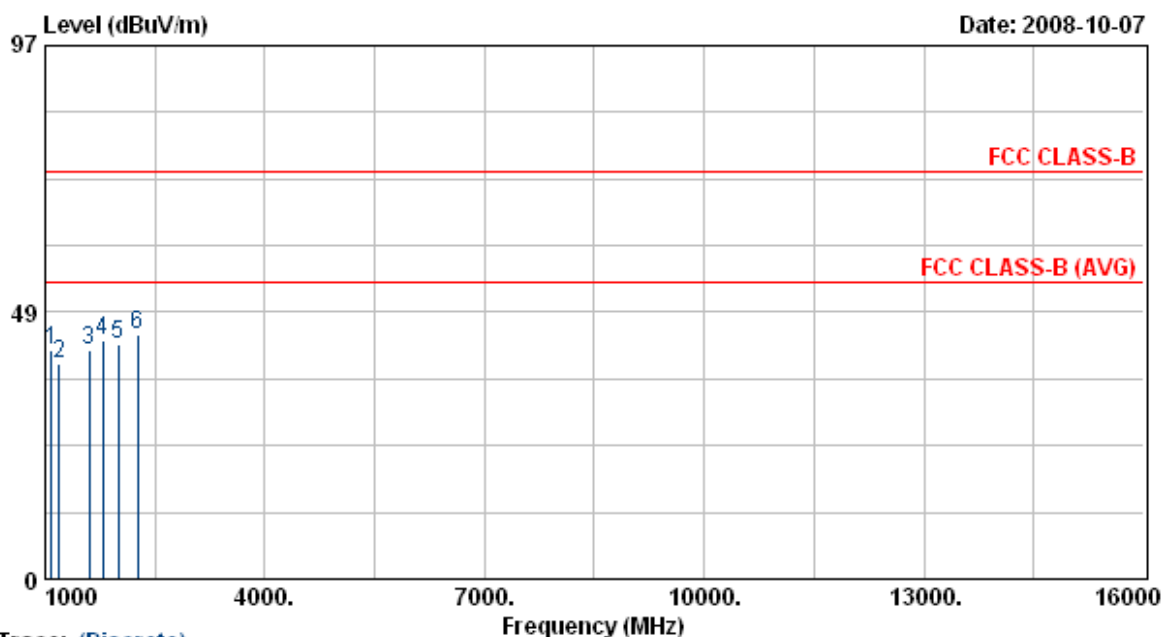

Trace: (Discrete)

Item	Freq MHz	Read Value dBuV/m	Factor dB	Result dBuV/m	Limit dBuV/m	Margin dB	Remark	Ant Pos cm	Tab Pos Deg
1	1091.00	51.67	-9.89	41.78	74.00	-32.22	Peak	100	360
2	1188.50	48.33	-9.34	38.99	74.00	-35.01	Peak	100	360
3	1598.00	48.71	-7.07	41.64	74.00	-32.36	Peak	100	360
4	1793.00	49.35	-6.02	43.33	74.00	-30.67	Peak	100	360
5	2001.00	47.59	-4.90	42.69	74.00	-31.31	Peak	100	360
6	2261.00	48.57	-3.96	44.61	74.00	-29.39	Peak	100	360

Remarks: 1. Result = Read Value + Factor  
 2. Factor = Antenna factor + Cable loss - Amplifier factor

Power	: AC 120V	Pol/Phase	: HORIZONTAL
Test Mode 2	: VGA: 1600 x 1200 75Hz	Temperature	: 28°C
	: DVI: 1024 x 768 75Hz	Humidity	: 72%

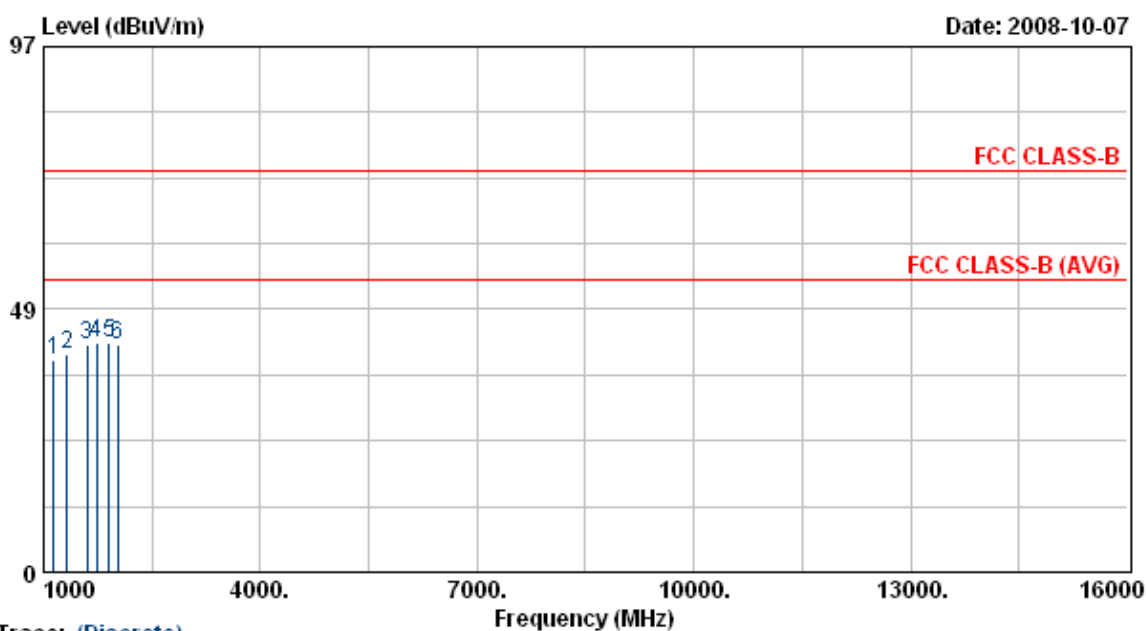

Trace: (Discrete)

Item	Freq MHz	Read Value dBuV/m	Factor dB	Result dBuV/m	Limit dBuV/m	Margin dB	Remark	Ant Pos cm	Tab Pos Deg
1	1143.00	48.75	-9.60	39.15	74.00	-34.85	Peak	100	0
2	1318.50	48.77	-8.62	40.15	74.00	-33.85	Peak	100	0
3	1598.00	48.99	-7.07	41.92	74.00	-32.08	Peak	100	0
4	1728.00	48.76	-6.37	42.39	74.00	-31.61	Peak	100	0
5	1903.50	47.88	-5.42	42.46	74.00	-31.54	Peak	100	0
6	2020.50	46.93	-4.83	42.10	74.00	-31.90	Peak	100	0

Remarks: 1. Result = Read Value + Factor  
 2. Factor = Antenna factor + Cable loss - Amplifier factor

Test engineer: Ray

### 3.6. Test Photographs

Front View



Rear View



Appendix A. Photographs of EUT











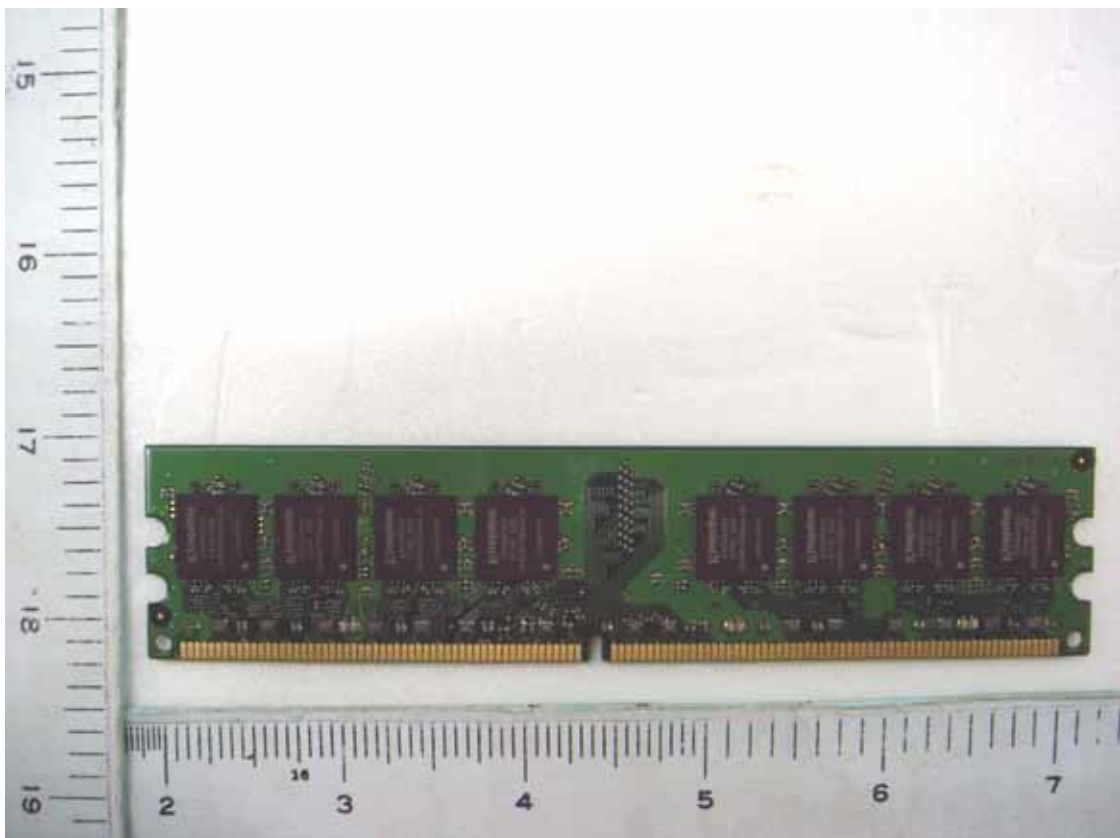

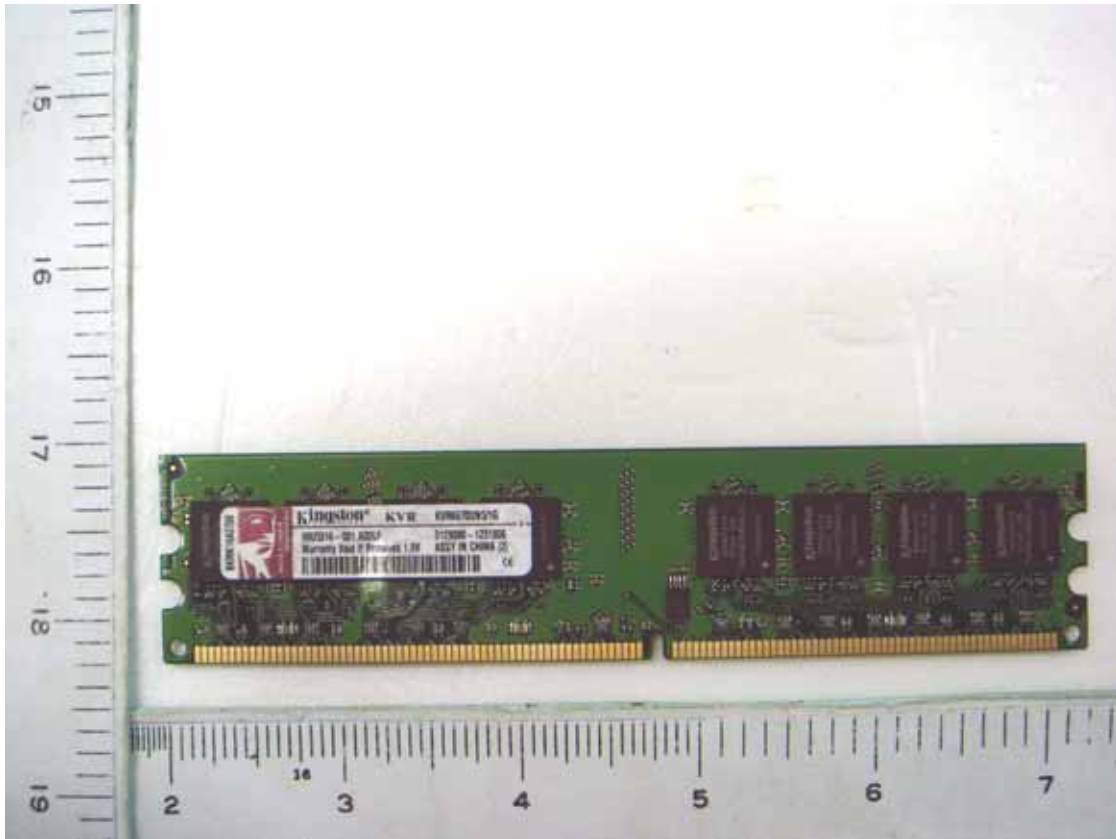





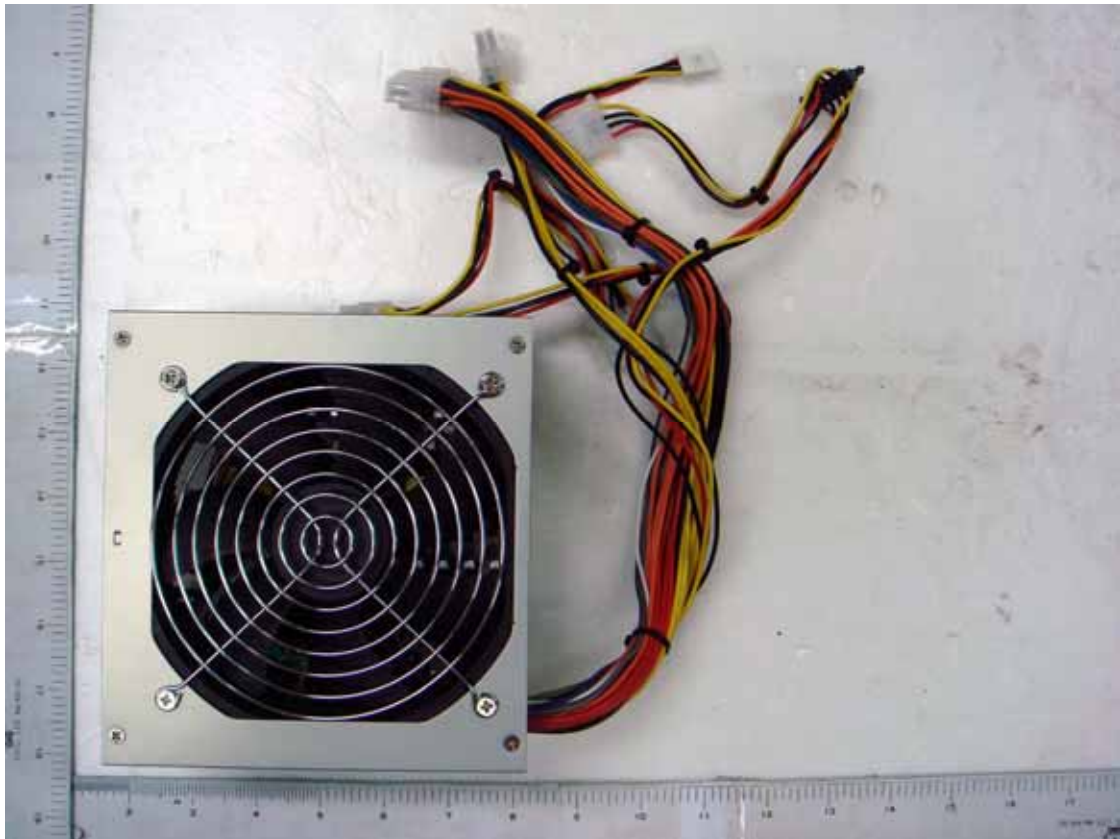









**POWER MAN**

MODEL NO (型號): IP-S350J2-0

**Switching Power Supply 交換式電源供應器 350W OUTPUT**

AC INPUT 交流輸入	115/230V~, 8/4A, 60/50Hz					
DC OUTPUT 直流輸出	+3.3V	+5V	+12V	-5V	-12V	+5Vsb
	20.0A	25.0A	18.0A	0.3A	0.8A	2.0A
	180.0W		216.0W		7.5W	
	335.0W			15.0W		

**WARNING: (警告)**

- HAZARDOUS VOLTAGE CONTAINED WITHIN THIS POWER SUPPLY.
- NOT USER SERVICEABLE RETURN SERVICE CENTER FOR REPAIR.
- 內有危險電壓請勿打開機殼! -選擇正確的輸入電壓值!



FC Tested to Comply With FCC Standards  
FOR HOME OR OFFICE USE Made in China, Pb-C