



No.198 Kezhu Road, Science Town Economic & Technology
Development District Guangzhou, China 510663 Telephone:

Telephone: +86 (0) 20 82155555

Fax: +86 (0) 20 82075059

Email: sgs_internet_operations@sgs.com

FEDERAL COMMUNICATIONS COMMISSION

Registration number: 282399

Report No.: GLEMR070401140RFT

Page: 1 of 9

FCC ID: UT7ULTIMASS127

TEST REPORT

Application No. : GLEMR070401140RF

Applicant: EMIRIMAGE CORPORATION

FCC ID: UT7ULTIMASS127

**Fundamental
Frequency :** 27.145MHz

Equipment Under Test (EUT):

Name: R/C TOYS SERIES

Model No.: TOU11459, TOU15401, TOU14789, TOU12741, TOU12742, TOU333I,
TOU3425, TOU15395, TOU7117, TOU9609♣

♣

Please refer to section 2 of this report which indicates which item was
actually tested and which were electrically identical.

Standards: FCC PART 15, SUBPART C : 2006
Section 15.227

Date of Receipt: 26 April 2007

Date of Test: 26 April and 29 May 2007

Date of Issue: 30 May 2007

Test Result :	PASS *
----------------------	---------------

* In the configuration tested, the EUT complied with the standards specified above.

Authorized Signature:

Stephen Guo
Manager

The manufacturer should ensure that all products in series production are in conformity with the product sample detailed in this report. If the product in this report is used in any configuration other than that detailed in the report, the manufacturer must ensure the new system complies with all relevant standards. Any mention of SGS International Electrical Approvals or testing done by SGS International Electrical Approvals in connection with, distribution or use of the product described in this report must be approved by SGS International Electrical Approvals in writing. The report must not be used by the client to claim product certification, approval, or endorsement by NVLAP, NIST, or any agency of the federal government. All test results in this report can be traceable to National or International Standards.

This Test Report is issued by the Company subject to its General Conditions of Service printed overleaf. Attention is drawn to the limitations of liability, indemnification and jurisdictional issues defined therein. The results shown in this test report refer only to the sample(s) tested unless otherwise stated. This Test Report cannot be reproduced, except in full, without prior written permission of the Company.

2 Test Summary

Test	Test Requirement	Standard Paragraph	Result
Radiated Emission (30MHz to 1000MHz)	FCC PART 15 :2006	Section 15.227	PASS *
Occupied Bandwidth	FCC PART 15 :2006	Section 15.215	PASS

Remark:

Model No.:TOU11459,TOU15401,TOU14789,TOU12741,TOU12742, TOU3331, TOU3425, TOU15395, TOU7117, TOU9609

According to the confirmation from the applicant,only the model TOU11459 was test, since the electrical circuit design, PCB layout, component used and internal wiring are identical for the above models, only the outer decoration ,color and models munbers are different.

* The EUT pass radiated emission test after modification carried out as below:

1. Add two capacitors for the Transmit circuit as the following figure shown.

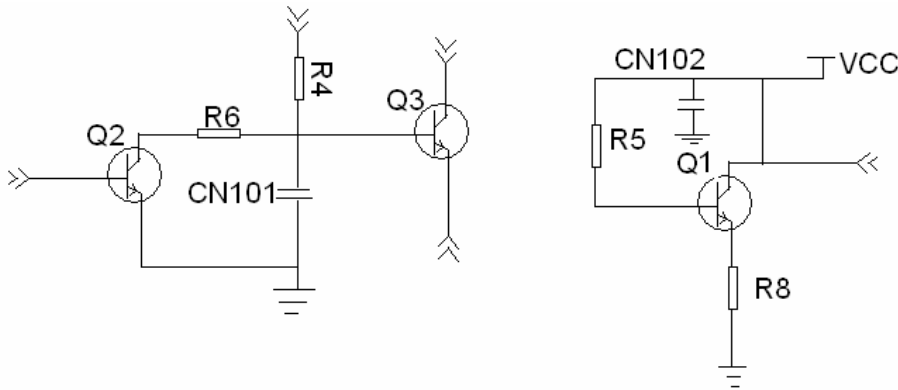

CN101, CN102: 0.1uF/16V

2. Replace the resistor R8 with a new one which resistance is 470ohm.
3. Replace the inductor L3 and L1 with new ones which inductance are 2.2uH.
4. Replace the L2 with new one which inductance is 5.6uH.



3 Contents

	Page
1 COVER PAGE	1
2 TEST SUMMARY	2
3 CONTENTS	3
4 GENERAL INFORMATION	4
4.1 CLIENT INFORMATION	4
4.2 DETAILS OF E.U.T.	4
4.3 DESCRIPTION OF SUPPORT UNITS	4
4.4 TEST LOCATION.....	4
4.5 OTHER INFORMATION REQUESTED BY THE CUSTOMER	4
4.6 TEST FACILITY.....	5
5 TEST RESULTS	6
5.1 TEST INSTRUMENTS.....	6
5.2 E.U.T. OPERATION.....	7
5.3 TEST PROCEDURE & MEASUREMENT DATA.....	7
5.3.1 <i>Radiated Emissions</i>	7
5.3.2 <i>Occupied Bandwidth</i>	9



4 General Information

4.1 Client Information

Applicant Name: EMIRIMAGE CORPORATION
Applicant Address: 5269 N. W. 161 Street, Miami, FL, 33014 USA

4.2 Details of E.U.T.

Name: R/C TOYS SERIES
Model No.: TOU11459, TOU15401, TOU14789, TOU12741, TOU12742, TOU3331, TOU3425, TOU15395, TOU7117, TOU9609
Power Supply: 12V DC (8 x1.5 'AA' Size Battery)
Power Cord: N/A-

4.3 Description of Support Units

The EUT was tested as an independent unit: a 27MHz radio transmitter.

4.4 Test Location

All tests were performed at:

SGS-CSTC Standards Technical Services Co., Ltd., Guangzhou EMC Laboratory, No.198 Kezhu Road, Science Town Economic & Technology Development District Guangzhou, China 510663

Tel: +86 20 82155555 Fax: +86 20 82075059

No tests were sub-contracted.

4.5 Other Information Requested by the Customer

None.



4.6 Test Facility

The test facility is recognized, certified, or accredited by the following organizations:

- **NVLAP – Lab Code: 200611-0**

SGS-CSTC Standards Technical Services Co., Ltd., Guangzhou EMC Laboratory is recognized under the National Voluntary Laboratory Accreditation Program (NVLAP/NIST). NVLAP Code: 200611-0.

- **FCC – Registration No.: 282399**

SGS-CSTC Standards Technical Services Co., Ltd., EMC Laboratory has been registered and fully described in a report filed with the (FCC) Federal Communications Commission. The acceptance letter from the FCC is maintained in our files. Registration 282399, May 31, 2002. With the above and NVLAP's accreditation, SGS-CSTC is an authorized test laboratory for the DoC process.



5 Test Results

5.1 Test Instruments

RE in Chamber/OATS						
No:	Test Equipment	Manufacturer	Model No.	Serial No.	Cal. Date (dd-mm-yy)	Cal.Due date (dd-mm-yy)
EMC0525	Compact Semi-Anechoic Chamber	ChangZhou ZhongYu	N/A	N/A	06-03-2007	06-03-2008
EMC0522	EMI Test Receiver	Rohde & Schwarz	ESIB26	100249	05-12-2006	05-12-2007
N/A	EMI Test Software	Audix	E3	N/A	N/A	N/A
EMC0514	Coaxial cable	SGS	N/A	N/A	04-12-2006	04-12-2007
EMC0524	Bi-log Type Antenna	Schaffner -Chase	CBL6112B	2966	31-10-2006	31-10-2007
EMC0519	Bilog Type Antenna	Schaffner -Chase	CBL6143	5070	31-07-2006	31-07-2007
EMC0517	Horn Antenna	Rohde & Schwarz	HF906	100095	29-07-2006	29-07-2007
EMC0040	Spectrum Analyzer	Rohde & Schwarz	FSP30	100324	05-12-2006	05-12-2007
EMC0520	0.1-1300 MHz Pre-Amplifier	HP	8447D OPT 010	2944A06252	28-03-2007	28-03-2008
EMC0521	1-26.5 GHz Pre-Amplifier	Agilent	8449B	3008A01649	28-03-2007	28-03-2008
EMC0523	Active Loop Antenna	EMCO	6502	00042963	09-08-2006	09-08-2008
EMC0530	10m Semi- Anechoic Chamber	ETS	N/A	N/A	22-08-2006	22-08-2007

General used equipment						
No:	Test Equipment	Manufacturer	Model No.	Serial No.	Cal. Date (dd-mm-yy)	Cal.Due date (dd-mm-yy)
EMC0050-EMC0053	Temperature, & Humidity	ZHENGZHOU BO YANG	WSB	N/A	05-12-2006	05-12-2007
EMC0054	Temperature, & Humidity	Shenzhen Tai Kong	THG-1	N/A	04-01-2007	04-01-2008
EMC0006	DMM	Fluke	73	70681569	27-09-2006	27-09-2007
EMC0007	DMM	Fluke	73	70671122	27-09-2006	27-09-2007

5.2 E.U.T. Operation

Input voltage: 12V DC (8 x1.5 'AA' Size Battery)
 Operating Environment:
 Temperature: 25.0 °C
 Humidity: 56 % RH
 Atmospheric Pressure: 1011 mbar
 EUT Operation: Test the EUT in transmitting mode.

5.3 Test Procedure & Measurement Data

5.3.1 Radiated Emissions

Test Requirement: FCC Part15 C Section 15.227
Test Method: ANSI C63.4 section 8 & 13
Test Date: May 18 2007(Initial test);May 29 2007(Final test)
Measurement Distance: 3m (Semi-Anechoic Chamber and OATS)
Requirements: Carrier frequency will not exceed 80dBuV/m at 3m.
 Out of band emissions shall not exceed:
 40.0 dBµV/m between 30MHz & 88MHz
 43.5 dBµV/m between 88MHz & 216MHz
 46.0 dBµV/m between 216MHz & 960MHz
 54.0 dBµV/m above 960MHz
Detector: Peak Scan (120kHz resolution bandwidth)

Test Procedure: The procedure used was ANSI Standard C63.4-2003. The receive was scanned from 30MHz to 1000MHz. When an emission was found, the table was rotated to produce the maximum signal strength. An initial pre-scan was performed for in peak detection mode using the receiver. The EUT was measured for both the Horizontal and Vertical polarities and performed a pre-test three orthogonal planes. The worst case emissions were reported.

An initial pre-scan was performed in the 3m chamber using the spectrum analyser in peak detection mode. Quasi-peak measurements were conducted based on the peak sweep graph. The EUT was measured by Active loop antenna and Bilog antenna with 2 orthogonal polarities

The following measurements were performed on the EUT on 29 May 2007.
 Test the EUT in transmitting mode.

Intentional emission

Test Frequency (MHz)	Peak (dBµV/m)		Limits (dBµV/m)	Margin (dB)	
	Vertical	Horizontal		Vertical	Horizontal
27.145	66.7	56.8	100.0	33.3	43.2

Test Frequency (MHz)	Average (dBµV/m)		Limits (dBµV/m)	Margin (dB)	
	Vertical	Horizontal		Vertical	Horizontal
27.145	63.6	52.1	80.0	16.4	27.9

Other emissions

Horizontal:



Freq	ReadAntenna	Cable	Preamp		Limit	Over	
Level	Factor	Loss	Factor	Level	Line	Limit	Remark
MHz	dBuV	dB/m	dB	dB	dBuV/m	dBuV/m	dB
54.290	35.14	9.93	0.50	25.21	20.35	40.00	-19.65 QP
81.435	21.86	9.47	0.60	25.12	6.81	40.00	-33.19 QP
108.580	21.71	12.51	0.70	25.10	9.82	43.50	-33.68 QP
135.725	21.70	11.88	0.80	25.10	9.27	43.50	-34.23 QP
162.870	21.66	9.84	0.90	24.88	7.52	43.50	-35.98 QP
168.870	21.38	9.17	0.90	24.84	6.61	43.50	-36.89 QP
190.015	22.05	8.93	1.00	24.70	7.28	43.50	-36.22 QP
217.160	22.62	10.56	1.10	24.53	9.75	46.00	-36.25 QP
244.305	23.30	12.35	1.15	24.42	12.37	46.00	-33.63 QP
271.450	21.49	12.65	1.12	24.40	10.86	46.00	-35.14 QP

Vertical:

Freq	ReadAntenna	Cable	Preamp		Limit	Over	
Level	Factor	Loss	Factor	Level	Line	Limit	Remark
MHz	dBuV	dB/m	dB	dB	dBuV/m	dBuV/m	dB
54.290	49.21	9.93	0.50	25.21	34.42	40.00	-5.58 QP
81.435	31.68	9.47	0.60	25.12	16.63	40.00	-23.37 QP
108.580	32.58	12.51	0.70	25.10	20.69	43.50	-22.81 QP
135.725	33.25	11.88	0.80	25.10	20.83	43.50	-22.67 QP
162.870	24.52	9.84	0.90	24.88	10.38	43.50	-33.12 QP
190.015	29.99	8.93	1.00	24.70	15.22	43.50	-28.28 QP
217.160	22.77	10.56	1.10	24.53	9.90	46.00	-36.10 QP
244.305	30.26	12.35	1.15	24.42	19.33	46.00	-26.67 QP
271.450	29.52	12.65	1.12	24.40	18.89	46.00	-27.11 QP

Remark:

According to 15.35 (b) When average radiated emission measurements are specified in the regulations, including emission measurements below 1000 MHz, there is also a limit on the radio frequency emissions, as measured using instrumentation with a peak detector function, corresponding to 20 dB above the maximum permitted average limit for the frequency being investigated unless a different peak emission limit is otherwise specified in the rules, e.g., see Section 15.255.

Test Results: The unit does meet the FCC Part 15 C Section 15.227 requirements.

5.3.2 Occupied Bandwidth

Test Requirement: FCC Part 15 C Section 15.215 (C)
 Test Method: ANSI C63.4 section 13 & FCC Part 2.1049
 Operation within the band 26.960 – 27.280 MHz
 Test Date: 18 May 2007

Requirements: Intentional radiators operating under the alternative provisions to the general emission limits, as contained in §§ 15.217 through 15.257 and in subpart E of this part, must be designed to ensure that the 20 dB bandwidth of the emission is contained within the frequency band designated in the rule section under which the equipment is operated. The requirement to contain the 20 dB bandwidth of the emission within the specified frequency band includes the effects from frequency sweeping, frequency hopping and other modulation techniques that may be employed as well as the frequency stability of the transmitter over expected variations in temperature and supply voltage. If a frequency stability is not specified in the regulations, it is recommended that the fundamental emission be kept within at least the central 80% of the permitted band in order to minimize the possibility of out-of-band operation.

Method of measurement: The useful radiated emission from the EUT was detected by the spectrum analyser with peak detector. The vertical Scale is set to 10dB per division. The horizontal scale is set to 5KHz per division.

20dB Bandwidth: 6.3KHz (27.1435MHz to 27.1498MHz)

The graph as below, represents the emissions take for this device.

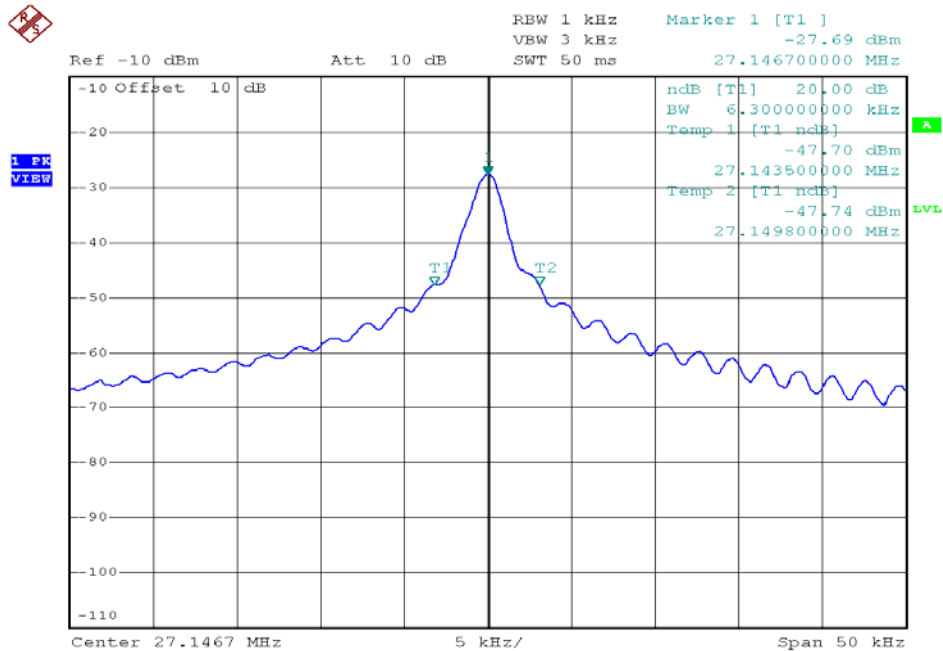

Date: 18.MAY.2007 12:20:36

The results: The unit does meet the FCC Part 15 C Section 15.215 requirements.