



BNetzA-CAB-21/21-21

Partial Test Report

Test report no.: 21086129-23009-1

Date of issue: 2021-12-08

Test result: The test item - **passed** - and complies with the listed standards.

Applicant

Mitsubishi Electric Corporation Sanda Works

Manufacturer

Mitsubishi Electric Corporation

Test Item

R1LOW-R-SBM

RF-Spectrum Testing according to:

FCC 47 CFR Part 15

Radio Frequency Devices (Subpart C)

RSS-247 Issue 2

Digital Transmission Systems (DTSs), Frequency Hopping Systems (FHSs) and Licence-Exempt Local Area Network (LE-LAN) Devices

RSS-Gen Issue 5

General Requirements for Compliance of Radio Apparatus

Tested by
(name, function, signature)

Piotr Sardyko
Deputy Head of Laboratory RF

signature

Approved by
(name, function, signature)

Dr.-Ing. Harald Ansorge
Managing Director

signature

Applicant and Test item details	
Applicant	Mitsubishi Electric Corporation Sanda Works 2-3-33, Miwa, Sanda-City, Hyogo 669-1513 Japan DESIGN-A SECTION, CAR MULTIMEDIA DESIGN DEPT. Fon: +81 79 559 4813 E-Mail: Yoshinaga.Ryuji@db.MitsubishiElectric.co.jp
Manufacturer	Mitsubishi Electric Corporation 2-3-33, Miwa, Sanda-City, Hyogo 669-1513 Japan DESIGN-A SECTION, CAR MULTIMEDIA DESIGN DEPT. Fon: +81 79 559 4813 E-Mail: Yoshinaga.Ryuji@db.MitsubishiElectric.co.jp
Test item description	Automotive Display Audio
Model/Type reference	R1LOW-R-SBM
Standard specific information	
FCC ID	UJH-R1LOW-R-SBM
IC	662K-R1LOWRSB
PMN	R1LOW-R-SBM
HVIN variant ID#28	28
HVIN variant ID#33	33
HVIN variant ID#39	39
HVIN variant ID#43	43
HVIN variant ID#48	48
FVIN	N/A
HMN	N/A
Frequency	2400 to 2483.5 MHz DTS band
Technology	Type of radio transmission: DSSS, OFDM Type of modulation: (D)BPSK, (D)QPSK, CCK, 16QAM, 64QAM
Number of channels	13 (20/22 MHz)
Antenna	external PCB antenna
Power supply	9 V – 16.5V, DC Battery
Temperature range	-40 °C to +75 °C

Disclaimer and Notes

The content of this test report relates to the mentioned test sample(s) only.
Without a written permit of IBL-Lab GmbH, this test report shall not be reproduced, except in full.

The last valid version is available at TAMSys®.

Copyright ©: All rights reserved by IBL-Lab GmbH

Within this test report, a point / comma is used as a decimal separator.
If otherwise, a detailed note is added adjoined to its use.

IBL-Lab GmbH does not take test samples. The sample used for testing is provided by the applicant.

Decision rule: Binary Statement for Simple Acceptance Rule according ILAC-G8:09/2019

1 TABLE OF CONTENTS

1	TABLE OF CONTENTS	4
2	GENERAL INFORMATION	5
2.1	Administrative details	5
2.2	Possible test case verdicts	5
2.3	Observations	6
2.4	Opinions and Interpretations	6
2.5	Revision History	6
2.6	Further documents	6
3	ENVIRONMENTAL & TEST CONDITIONS	7
3.1	Environmental conditions	7
3.2	Normal and extreme test conditions	7
4	TEST STANDARDS AND REFERENCES	7
5	EQUIPMENT UNDER TEST (EUT)	8
5.1	Product Description	8
5.2	Test Item Description	8
5.3	Technical Data of Equipment	9
5.4	Additional Information	10
5.5	Test modes	11
6	SUMMARY OF TEST RESULTS	12
7	TEST RESULTS	13
7.1	RF Output Power (Conducted Peak Power)	13
7.2	Antenna Gain (calculated)	15
7.3	Band Edge Compliance (BEC), radiated	16
7.4	Radiated Spurious Emissions (RSE)	18
8	TEST SETUP DESCRIPTION	20
8.1	Semi Anechoic Chamber with Ground Plane	20
8.2	Fully Anechoic Chamber	22
8.3	Radiated measurements > 18 GHz	24
8.4	Conducted measurements WLAN test system R&S TS 8997	25
9	MEASUREMENT UNCERTAINTIES	26

2 GENERAL INFORMATION

2.1 Administrative details

Testing laboratory	IBL-Lab GmbH Heinrich-Hertz-Allee 7 66386 Sankt Ingbert / Germany Fon: +49 6894 38938-0 Fax: +49 6894 38938-99 URL: www.ib-lenhardt.de E-Mail: info@ib-lenhardt.de
Accreditation	The testing laboratory is accredited by Deutsche Akkreditierungsstelle GmbH (DAkKS) in compliance with DIN EN ISO/IEC 17025:2018. Scope of testing and registration number: <ul style="list-style-type: none"> • Electronics D-PL-21375-01-01 • Electromagnetic Compatibility D-PL-21375-01-02 • Electromagnetic Compatibility and Telecommunication (FCC requirements) D-PL-21375-01-03 • Telecommunication (TC) and Electromagnetic Compatibility (EMC) for Canadian Standards D-PL-21375-01-04 • ISED Company Number 27156 • Testing Laboratory CAB Identifier DE0020 • Telekommunikation (TK) D-PL-21375-01-05 Website DAkKS: https://www.dakks.de/ The Deutsche Akkreditierungsstelle GmbH (DAkKS) is also a signatory to ILAC Mutual Recognition Arrangement
Testing location	IBL-Lab GmbH Heinrich-Hertz-Allee 7 66386 St. Ingbert / Germany
Date of receipt of test samples	2021-09-30
Start – End of tests	2021-10-04 – 2021-11-18

2.2 Possible test case verdicts

Test sample meets the requirements	P (PASS)
Test sample does not meet the requirements	F (FAIL)
Test case does not apply to the test sample	N/A (Not applicable)
Test case not performed	N/P (Not performed)

2.3 Observations

No additional observations other than the reported observations within this test report have been made.

2.4 Opinions and Interpretations

No appropriate opinions or interpretations according ISO/IEC 17025:2017 clause 7.8.7 are within this test report.

2.5 Revision History

-0 Initial Version

-1 Revision: administrative modification/correction

Change of HVIN

This test report 21086129-23009-1 replaces the previous test report 21086129-23009-0.

Utilisation, publication and control of previous report editions is under responsibility of the applicant.

2.6 Further documents

List of further applicable documents belonging to the present test report:

- TR-21086129-23009-1 (test report).pdf (latest available version)
- TR-21086129-23009-1_AnnexA (test results EUT).pdf
- TR-21086129-23009-1_AnnexB (external photos EUT).pdf
- TR-21086129-23009-1_AnnexC (internal photos EUT).pdf
- TR-21086129-23009-1_AnnexD (test setup FCC - IC).pdf

3 ENVIRONMENTAL & TEST CONDITIONS

3.1 Environmental conditions

Temperature	20°C ± 5°C
Relative humidity	25-75 % r.H.
Barometric Pressure	860-1060 mbar
Power supply	230 V / 50 Hz

3.2 Normal and extreme test conditions

	minimum	nominal	maximum
Temperature	-/-	+25 °C	-/-
Relative humidity	-/-	50 % r.h.	-/-
Power supply	-/-	12.6 V DC	-/-

4 TEST STANDARDS AND REFERENCES

Test standard (accredited)	Description
FCC 47 CFR Part 15	Radio Frequency Devices (Subpart C)
RSS-247 Issue 2	Digital Transmission Systems (DTSs), Frequency Hopping Systems (FHSs) and Licence-Exempt Local Area Network (LE-LAN) Devices
RSS-Gen Issue 5	General Requirements for Compliance of Radio Apparatus

Test standard (not accredited)	Description
none	---

Reference	Description
ANSI C63.4-2014	American National Standard for Methods of Measurement of Radio-Noise Emissions from Low-Voltage Electrical and Electronic Equipment in the Range of 9 kHz to 40 GHz
ANSI C63.10-2013	American National Standard of Procedures for Compliance Testing of Unlicensed Wireless Devices
558074 D01 15.247 Meas Guide v05r02	Guidance for compliance measurements on digital transmission systems, frequency hopping spread spectrum systems and hybrid system devices operating under section 15.247 of the FCC rules

5 EQUIPMENT UNDER TEST (EUT)

5.1 Product Description

Automotive Display Audio

*: as declared by applicant

5.2 Test Item Description

Model name*	R1LOW-R-SBM
EUT status*	PrePV
Serial number*	ID#28: mechanical variant SBX, electrical variant 30 (lead model) ID#33: mechanical variant SBX, electrical variant 31 ID#39: mechanical variant SBX, electrical variant 60 ID#43: mechanical variant SBX, electrical variant 40 ID#48: mechanical variant SBX, electrical variant 41
Serial number of EUT test samples*	ID#28: radiated EUT: 65108 conducted EUT: 65112 ID#33: radiated EUT: 66605 conducted EUT: - ID#39: radiated EUT: 65334 conducted EUT: 65332 ID#43: radiated EUT: 66704 conducted EUT: - ID#48: radiated EUT: 66804, 66805 conducted EUT: -
PCB identifier*	NJ00193612
Hardware status*	NR-0C-R-PrePV
Software status*	Android 10

*: as declared by applicant; please see TR-21086129-23009-1_AnnexB , TR-21086129-23009-1_AnnexC for EUT photographs.

5.3 Technical Data of Equipment	
Operational frequency band*	2400 to 2483.5 MHz DTS band
Transmitter*	Chip QCA6574AU with 48 MHz TCXO (Module UGKZ5A3006A)
Technology*	802.11 b/g/n, DSSS, OFDM
Modulation type*	802.11 b: DBPSK, DQPSK, CCK 802.11 g: BPSK, QPSK, 16QAM, 64QAM 802.11 n: BPSK, QPSK, 16QAM, 64QAM
Data rate*	802.11 b: 1 Mbps – 11 Mbps 802.11 g: 6 Mbps – 54 Mbps 802.11 n: 6.5 Mbps – 144.4 Mbps
Number of channels*	13
Channel bandwidth*	22 MHz (b-mode) / 20 MHz (g-, n-mode)
Channel spacing*	5 MHz
Guard Interval*	802.11n: GI=800 ns, GI=400 ns
Rated RF Output Power*	Maximum rated RF output power is maximum measured RF output power value (see section 7.1) plus 2dB: 802.11 b: 15 dBm 802.11 g: 13 dBm 802.11 n: 13 dBm
Antenna R1LOW-R-SBM model* Part name Antenna 0	external PCB antenna P68306857AA/00534042660 #0
Antenna gain R1LOW-R-SBM model *	Antenna 0: 1.85 dBi
Antenna R1LOW-R model* Part name Antenna 0	Sheet metal antenna, 2342059-2
Antenna gain R1LOW-R model*	Antenna 0: -3.55 dBi
Number of Spatial Streams*	NSS=1, NSS=2
Power supply, V_{nom}*	9 V – 16.5V, DC Battery, $V_{nom}=12.6$ V
Temperature range, T_{nom}*	-40 °C to +75 °C, $T_{nom}=+25$ °C

*: as declared by applicant

Channels with **22 MHz (b-mode) / 20 MHz (g-, n-mode)** channel bandwidth:

2400 to 2483.5 DTS band													
channel number & center frequency													
channel	1	2	3	4	5	6	7	8	9	10	11	12	13
f_c / MHz	2412	2417	2422	2427	2432	2437	2442	2447	2452	2457	2462	2467	2472

5.4 Additional Information

Model variant differences*	<ul style="list-style-type: none"> • R1LOW-R DV model with integrated sheet metal antenna and associated display, PCB ID NJ00193611 • R1LOW-R-SBM DV model with external antenna and disassociated display, PCB ID NJ00193611 • R1LOW-R-SBM PrePV model with external antenna and disassociated display, PCB ID NJ00193612 <p>Applicant declares that transmitter module with chip and external antenna are identical in R1LOW-R-SBM DV model (see IBL-Lab test report TR-21086129-23009-1) and R1LOW-R-SBM PrePV model.</p> <p>Electrical variants of R1LOW-R-SBM PrePV model listed in section 5.2 refer to different memory chipsets and multimedia chipsets and interfaces.</p> <p>Test results of R1LOW-R-SBM DV model are used for following test cases (see IBL-Lab test report TR-21086129-23009-1):</p> <ul style="list-style-type: none"> • DTS bandwidth (6 dB) • Occupied Channel Bandwidth (99%) • Peak power spectral density (PSD) • Band edge compliance (BEC), conducted • Conducted spurious emissions (CSE) <p>Conducted R1LOW-R-SBM PrePV test samples of model variants #28, #39 are used for following test cases:</p> <ul style="list-style-type: none"> • RF output power (conducted peak power) <p>Radiated R1LOW-R-SBM PrePV test samples of model variants #28, #39 are used for following test cases:</p> <ul style="list-style-type: none"> • Antenna gain (calculated) <p>Radiated R1LOW-R-SBM PrePV test samples of all model variants are used for following test cases:</p> <ul style="list-style-type: none"> • Band edge compliance (BEC), radiated • Radiated spurious emissions (RSE) – worst case from R1LOW-R-SBM DV tests (see IBL-Lab test report TR-21086129-23009-1)
Ancillaries tested with	None
Additional equipment used for testing	Notebook with test tool

*: as declared by applicant

5.5 Test modes	
Mode 1, b-mode	22 MHz bandwidth, Modulation type: DBPSK 1 Mbps*
	20 MHz bandwidth, Modulation type: BPSK 6 Mbps*
Mode 3, n-HT20 mode	20 MHz bandwidth, Modulation type: BPSK 6.5 Mbps, NSS=1*
Channel	Channels used for testing are marked in bold in 20 MHz channel list (see section 5.3)
Antennas and transmit operating mode	Equipment with 2 antennas/transmit chains (antenna 0, antenna 1); apart from conducted output power all other test cases can be performed with one antenna only (antenna 0)
Worst case configuration with respect to RF output power	<p>Conducted RF output power of R1LOW-R DV model has been measured for following modulation types, spatial streams and data rates at low, mid, and high channel frequencies marked in bold in 20 MHz channel list (see section 5.3):</p> <ul style="list-style-type: none"> - 802.11b, DBPSK, 1 Mbps, antenna 0, antenna 1, antenna 0 + 1 - 802.11b, DBPSK, 1 Mbps, antenna 0 + 1 - 802.11b, DQPSK, 2 Mbps, antenna 0 + 1 - 802.11b, CCK, 5.5 Mbps, antenna 0 + 1 - 802.11b, CCK, 11 Mbps, antenna 0 + 1 - 802.11g, BPSK, 6 Mbps, antenna 0, antenna 1, antenna 0 + 1 - 802.11g, QPSK, 12 Mbps, antenna 0 + 1 - 802.11g, 16 QAM, 24 Mbps, antenna 0 + 1 - 802.11g, 64 QAM, 24 Mbps, antenna 0 + 1 - 802.11n, BPSK, 6.5 Mbps, antenna 0 - 802.11n, QPSK, 13 Mbps, antenna 0 - 802.11n, 16 QAM, 26 Mbps, antenna 0 - 802.11n, 64 QAM, 52 Mbps, antenna 0 <p>* From conducted RF output measurements of R1LOW-R DV model test mode 1, 2, 3 have been selected based on measured maximum conducted output power</p>

6 SUMMARY OF TEST RESULTS

Test specification
FCC 47 CFR Part 15 RSS-247 Issue 2 / RSS-Gen Issue 5

Clause	Requirement / Test Case	Result - Remark	Verdict
§15.247(a)(2) RSS-247, 5.2 (a)	DTS bandwidth (6 dB)	KDB 558074, clause: 8.2	- N/P - *
RSS Gen, 6.7	Occupied bandwidth (99%)	-/-	- N/P - *
§15.247(b)(3) RSS-247, 5.4 (d)	RF output power (conducted peak power)	KDB 558074, clause: 8.3.1	- PASS -
§15.247(b)(4) RSS-247, 5.4 (d)	Antenna gain (calculated)	-/-	- PASS -
§15.247(e) RSS-247, 5.2 (b)	Peak power spectral density (PSD)	KDB 558074, clause: 8.4	- N/P - *
§15.247(d) RSS-247, 5.5	Band edge compliance (BEC), conducted	KDB 558074, clause: 8.5	- N/P - *
§15.247(d) RSS-247, 5.5	Band edge compliance (BEC), radiated	KDB 558074, clause: 8.7	- PASS -
§15.247(d) RSS-247, 5.5	Conducted spurious emissions (CSE)	KDB 558074 DTS clause: 8.5	- N/P - *
§15.247(d) / §15.209 RSS-247, 5.5 / RSS-Gen, 8.9	Radiated spurious emissions (RSE)	-/-	- PASS -
§15.207 RSS-Gen, 8.8	AC conducted emissions	EUT is battery powered	- N/A -

*) see IBL-Lab test report TR-21086129-23009-1

Comments and observations

Following pages show requirements and references of FCC Part 15.247, ANSI C63.10 and KDB 558074 only. Same tests are also applicable and valid for RSS-247, with clauses given in table above.

7 TEST RESULTS

7.1 RF Output Power (Conducted Peak Power)

Applicability

This requirement applies to all types of DTS equipment.

Description

The RF Output Power is defined as the conducted peak output power.

Limit

§15.247

(b) The maximum peak conducted output power of the intentional radiator shall not exceed the following:

(3) For systems using digital modulation in the 902-928 MHz, 2400-2483.5 MHz, and 5725-5850 MHz bands: 1 Watt. As an alternative to a peak power measurement, compliance with the one Watt limit can be based on a measurement of the maximum conducted output power. Maximum Conducted Output Power is defined as the total transmit power delivered to all antennas and antenna elements averaged across all symbols in the signaling alphabet when the transmitter is operating at its maximum power control level. Power must be summed across all antennas and antenna elements. The average must not include any time intervals during which the transmitter is off or is transmitting at a reduced power level. If multiple modes of operation are possible (e.g., alternative modulation methods), the *maximum conducted output power* is the highest total transmit power occurring in any mode.

(4) The conducted output power limit specified in paragraph (b) of this section is based on the use of antennas with directional gains that do not exceed 6 dBi.

Test procedure

KDB 558074 D01.

ANSI C63.10, 11.9.2.3.2

Method AVGPM-G is a measurement using a gated RF average power meter.

Alternatively, measurements may be performed using a wideband gated RF power meter provided that the gate parameters are adjusted such that the power is measured only when the EUT is transmitting at its maximum power control level. Because the measurement is made only during the ON time of the transmitter, no duty cycle correction factor is required.

Gate triggering can be implemented in such a way that the sweep of the instrument is only active during the burst period of the device. Any Gate triggering shall be performed on the full power portion of the pulses and care must be taken to ensure that static portions of the pulse are not included in the measurement (ensuring that the trace is averaged over the entire symbol range). All Gate triggered measurements shall be accompanied by a Gate setup plot in the test report.

Test setup: 8.4 with conducted test sample (see section 5.2); test setup photographs see TR-21086129-23009-1_AnnexD

Test Results				
EUT ID, Test Mode	RF Output Power (Conducted Peak Power)			Limit [dBm]
	low channel [dBm]	mid channel [dBm]	high channel [dBm]	
EUT ID#28, Mode 1	13.6	13.2	13.1	30
EUT ID#39, Mode 1	13.0	12.7	12.5	30
EUT ID#28, Mode 2	10.9	10.6	10.5	30
EUT ID#39, Mode 2	10.3	10.0	9.9	30
EUT ID#28, Mode 3	10.7	10.4	10.3	30
EUT ID#39, Mode 3	10.0	9.8	9.6	30

Comment:	---
-----------------	-----

Verdict	- PASS -	plots see TR-21086129-23009-1_AnnexA
----------------	-----------------	--------------------------------------

7.2 Antenna Gain (calculated)
Applicability This requirement applies to all types of DTS equipment.
Description The antenna gain is defined as the difference between radiated peak power (Peak EIRP) subtracted by the conducted peak power of the module, given in dBi.
Limit §15.247 (b)(4) The conducted output power limit specified in paragraph (b) of this section is based on the use of antennas with directional gains that do not exceed 6 dBi.
Test setup: 8.2 with radiated test sample (see section 5.2), 8.4 with conducted test sample (see section 5.2); test setup photographs see TR-21086129-23009-1_AnnexD

Test Results

EUT ID #28, Mode 1	low channel	high channel	Limit
Radiated peak power [dBm]	15.1	15.8	≤ 36
Conducted peak power [dBm]	13.6	13.1	≤ 30
Calculated antenna gain [dBi]	1.5	2.7	≤ 6

EUT ID #39, Mode 1	low channel	high channel	Limit
Radiated peak power [dBm]	14.9	15.6	≤ 36
Conducted peak power [dBm]	13.0	12.5	≤ 30
Calculated antenna gain [dBi]	1.9	3.1	≤ 6

Comment:	---
-----------------	-----

Verdict	- PASS -	plots see TR-21086129-23009-1_AnnexA
----------------	-----------------	--------------------------------------

7.3 Band Edge Compliance (BEC), radiated

Applicability

This requirement applies to all types of DTS equipment.

Description

Emissions within a restricted band and within 2 MHz of an authorized band edge may be measured using either the marker-delta method (ANSI C63.10, 6.10.6) or the integration method (ANSI C63.20, 11.13.3), provided that the DTS bandwidth (or EBW) edge falls within 2 MHz of the band edge. Otherwise, all unwanted emissions measurements shall be performed using the standard methods.

Limits

§15.247

(d) In any 100 kHz bandwidth outside the frequency band in which the spread spectrum or digitally modulated intentional radiator is operating, the radio frequency power that is produced by the intentional radiator shall be at least 20 dB below that in the 100 kHz bandwidth within the band that contains the highest level of the desired power, based on either an RF conducted or a radiated measurement, provided the transmitter demonstrates compliance with the peak conducted power limits. If the transmitter complies with the conducted power limits based on the use of RMS averaging over a time interval, as permitted under paragraph (b)(3) of this section, the attenuation required under this paragraph shall be 30 dB instead of 20 dB. Attenuation below the general limits specified in §15.209(a) is not required. In addition, radiated emissions which fall in the restricted bands, as defined in §15.205(a), must also comply with the radiated emission limits specified in §15.209(a) (see §15.205(c)).

Test procedure

The marker-delta method as described in ANSI C63.10, 6.10.6 or the integration method as described in ANSI C63.10, 11.13.3 can be used to perform measurements of the unwanted emissions level at the band edges.



Test setup: 8.2 with radiated test sample (see 5.2)

Test results			
EUT ID, testing mode	low channel AVG / Peak [dµV/m @3m]	high channel AVG / Peak [dµV/m @3m]	Limit AVG / Peak [dµV/m @3m]
EUT ID#28, Mode 1	≤ 50 AVG / ≤ 60 PK	≤ 54 AVG / ≤ 74 PK	≤ 54 AVG / ≤ 74 PK
EUT ID#33, Mode 1	≤ 50 AVG / ≤ 60 PK	≤ 50 AVG / ≤ 64 PK	≤ 54 AVG / ≤ 74 PK
EUT ID#39, Mode 1	≤ 50 AVG / ≤ 60 PK	≤ 50 AVG / ≤ 63 PK	≤ 54 AVG / ≤ 74 PK
EUT ID#43, Mode 1	≤ 50 AVG / ≤ 60 PK	≤ 50 AVG / ≤ 63 PK	≤ 54 AVG / ≤ 74 PK
EUT ID#48, Mode 1	≤ 50 AVG / ≤ 60 PK	≤ 50 AVG / ≤ 68 PK	≤ 54 AVG / ≤ 74 PK

Comment:	---
-----------------	-----

Verdict	- PASS -	plots see TR-21086129-23009-1_AnnexA *
----------------	-----------------	--

* description of traces for radiated Bend Edge Compliance (BEC) measurements:

-  positive Peak (Max Hold) trace
-  average Peak (Max Hold) trace

7.4 Radiated Spurious Emissions (RSE)

Applicability

This requirement applies to all types of DTS equipment.

Description

Spurious emission / unwanted emissions are emission on a frequency or frequencies which are outside the authorized band and the level of which may be reduced without affecting the corresponding transmission of information. Spurious emissions include harmonic emissions, parasitic emissions, intermodulation products and frequency conversion products. Measurements shall be made to detect spurious emissions that may be radiated directly from the cabinet, control circuits, power leads, or intermediate circuit elements under normal conditions of installation and operation.

Limits

In any 100 kHz bandwidth outside the frequency band in which the spread spectrum or digitally modulated intentional radiator is operating, the radio frequency power that is produced by the intentional radiator shall be at least 20 dB below that in the 100 kHz bandwidth within the band that contains the highest level of the desired power, based on either an RF conducted or a radiated measurement. Attenuation below the general limits specified in Section 15.209(a) is not required. In addition, radiated emissions which fall in the restricted bands, as defined in §15.205(a), must also comply with the radiated emission limits specified in §15.209(a) (see §15.205(c)).

Frequency [MHz]	Field Strength [$\mu\text{V}/\text{m}$] / [dB $\mu\text{V}/\text{m}$]	Measurement distance [m]
0.009 – 0.490	2400/F[kHz]	300
0.490 – 1.705	24000/F[kHz]	30
1.705 – 30.0	30.0 / 29.5	30
30 – 88	100 / 40.0	3
88 – 216	150 / 43.5	3
216 – 960	200 / 46.0	3
960 – 40 000	500 / 54.0	3

Note

Radiated Spurious Emissions (RSE) are performed for low / mid / high channel.



Test setup: 8.1, 8.2, 8.3 with radiated test sample (see section 5.2); test setup photographs see TR-21086129-23009-1_AnnexD

Test results: Test Mode 1, b-mode, 22 MHz bandwidth, Modulation type: DBPSK 1 Mbps					
EUT ID / Channel	Frequency [MHz]	Peak/RMS Detector	Level* [dBm]	Limit [dBm]	Verdict
EUT ID#28, 1	see plots	MaxPeak	see plots	see plots	- PASS -
EUT ID#28, 13	see plots	MaxPeak	see plots	see plots	- PASS -
EUT ID#33, 1	see plots	MaxPeak	see plots	see plots	- PASS -
EUT ID#33, 13	see plots	MaxPeak	see plots	see plots	- PASS -
EUT ID#39, 1	see plots	MaxPeak	see plots	see plots	- PASS -
EUT ID#39, 13	see plots	MaxPeak	see plots	see plots	- PASS -
EUT ID#43, 1	see plots	MaxPeak	see plots	see plots	- PASS -
EUT ID#43, 13	see plots	MaxPeak	see plots	see plots	- PASS -
EUT ID#48, 1	see plots	MaxPeak	see plots	see plots	- PASS -
EUT ID#48, 13	see plots	MaxPeak	see plots	see plots	- PASS -

Comment:	---
-----------------	-----

Verdict	- PASS -	plots see TR-21086129-23009-1_AnnexA *
----------------	-----------------	--

* description of line and marker for all radiated spurious emission (RSE) measurements:

-  positive Peak (Max Hold) trace during pre-scan
-  Max Peak value
-  final Quasi Peak value

8 TEST SETUP DESCRIPTION

8.1 Semi Anechoic Chamber with Ground Plane

Radiated measurements are performed in vertical and horizontal plane in the frequency range 30 MHz to 1 GHz in a Semi Anechoic Chamber with a metallic ground plane. The EUT is positioned on a non-conductive test table with a height of 0.80 m above the metallic ground plane that covers the whole chamber. The receiving antennas conform to specification ANSI C63.10-2013, American National Standard for Testing Unlicensed Wireless Devices. These antennas can be moved over the height range between 1.0 m and 4.5 m in order to search for maximum field strength emitted from the EUT. The measurement distances between EUT and receiving antennas are indicated in the test setups for the various frequency ranges. For each measurement, the EUT is rotated in all three axes until the maximum field strength is received. The wanted and unwanted emissions are received by a spectrum analyzer where the detector modes and resolution bandwidths over various frequency ranges are set according to requirement ANSI C63.

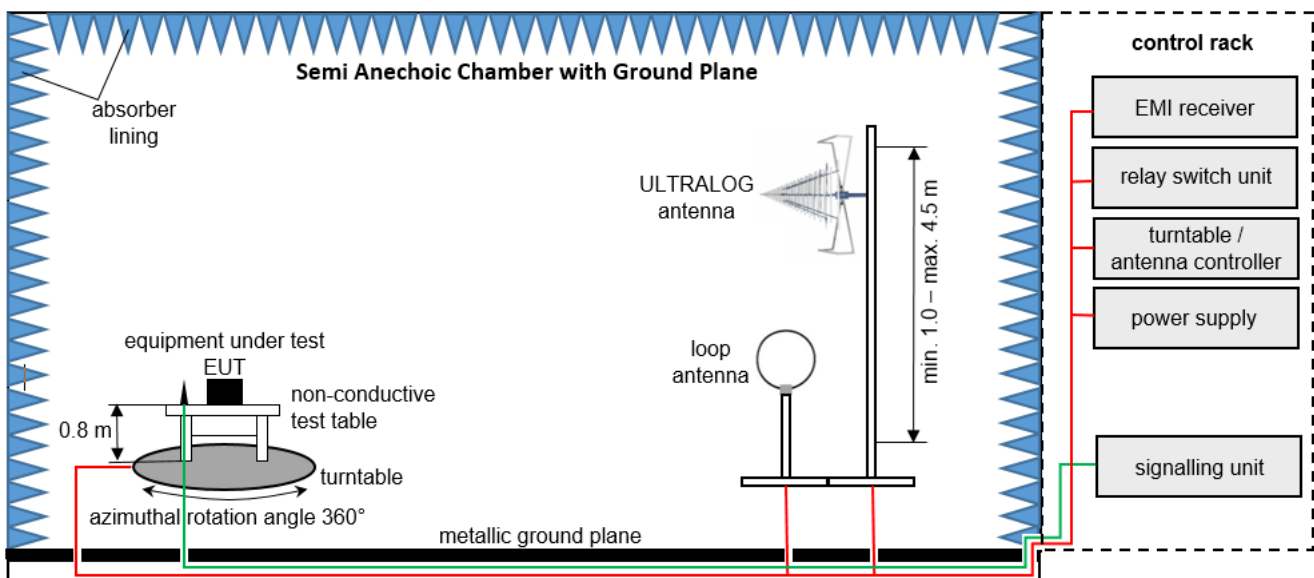

Measurement distance: loop antenna 3 m, ULTRALOG antenna 3 m
 EMC32 software version: 11.10.00

$$FS = UR + CL + AF$$

(FS-field strength; UR-voltage at the receiver; CL-loss of the cable; AF-antenna factor)

Example calculation:

$$FS \text{ [dB}\mu\text{V/m]} = 12.35 \text{ [dB}\mu\text{V/m]} + 1.90 \text{ [dB]} + 16.80 \text{ [dB/m]} = 31.05 \text{ [dB}\mu\text{V/m]} \text{ (35.69 } \mu\text{V/m)}$$

List of test equipment used:

No.	Equipment	Manufacturer	Type	Serial No.	INV. No.	Last / Next Calibration
1	Power Supply	Elektro-Automatik GmbH & Co. KG	EA-PSI 9080-40 T	2000230001	LAB000313	–
2	Test table	innco systems GmbH	PT1208-080-RH	-	LAB000306	–
3	Power Supply	Chroma	61604	616040005416	LAB000285	–
4	Positioner	matur GmbH	TD 1.5-10KG		LAB000258	–
5	Compressed Air	Implotex	1-850-30	-	LAB000256	–
6	EMI Test Receiver	Rohde & Schwarz	ESW26	101517	LAB000363	2021-02-05 → 2022-02-05
7	Semi-Anechoic Chamber (SAC)	Albatross Projects GmbH	SAC 5 (Babylon 5)	20168.PRB	LAB000235	2020-08-24 → 2021-08-24
8	Measurement Software	Rohde & Schwarz	EMC32 V11.00.10		LAB000226	–
9	Turntable	matur GmbH	TT2.0-2t	TT2.0-2t/921	LAB000225	–
10	Antenna Mast	matur GmbH	CAM4.0-P	CAM4.0-P/316	LAB000224	–
11	Antenna Mast	matur GmbH	BAM4.5-P	BAM4.5-P/272	LAB000223	–
12	Controller	matur GmbH	FCU 3.0	10082	LAB000222	–
13	Power Supply	Elektro-Automatik GmbH & Co. KG	PS 2042-10 B	2878350292	LAB000191	–
14	Pre-Amplifier	Schwarzbeck Mess-Elektronik OHG	BBV 9718 C	84	LAB000169	–
15	Open Switch and Control Platform	Rohde & Schwarz	OSP200 Base Unit 2HU	101748	LAB000149	–
16	Antenna	Rohde & Schwarz	HL562E	102001	LAB000123	2020-07-05 → 2023-07-05
17	Antenna	Rohde & Schwarz	HFH2-Z2E - Active Loop Antenna	100954	LAB000108	2020-03-25 → 2023-03-25

8.2 Fully Anechoic Chamber

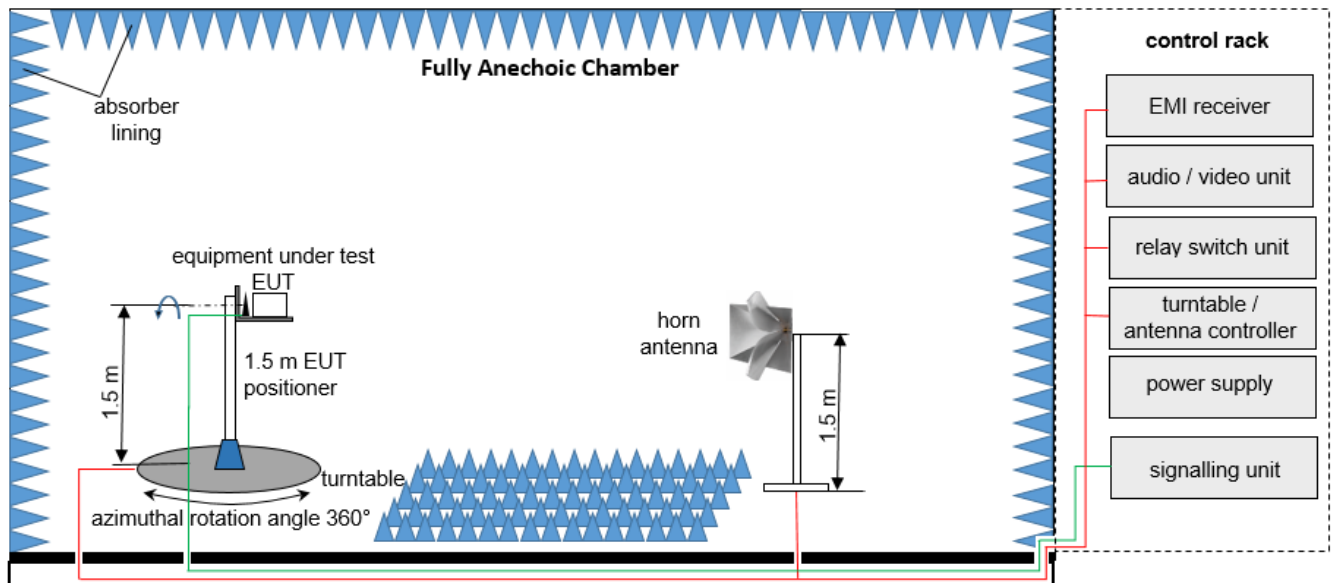

Measurement distance: horn antenna 3 meter

EMC32 software version: 11.10.00

$$FS = UR + CL + AF$$

(FS-field strength; UR-voltage at the receiver; CL-loss of the cable; AF-antenna factor)

Example calculation:

$$FS [dB\mu V/m] = 12.35 [dB\mu V/m] + 1.90 [dB] + 16.80 [dB/m] = 31.05 [dB\mu V/m] (35.69 \mu V/m)$$

$$OP = AV + D - G + CA$$

(OP-radiated output power; AV-analyzer value; D-free field attenuation of measurement distance; G-antenna gain+amplifier gain; CA-loss signal path)

Example calculation:

$$OP [dBm] = -65.0 [dBm] + 50 [dB] - 20 [dBi] + 5 [dB] = -30 [dBm] (1 \mu W)$$

List of test equipment used:

No.	Equipment	Manufacturer	Type	Serial No.	INV. No.	Last / Next Calibration
1	Power Supply	Elektro-Automatik GmbH & Co. KG	EA-PSI 9080-40 T	2000230001	LAB000313	–
2	Test table	innco systems GmbH	PT1208-080-RH	-	LAB000306	–
3	Power Supply	Chroma	61604	616040005416	LAB000285	–
4	Positioner	matur GmbH	TD 1.5-10KG	–	LAB000258	–
5	Compressed Air	Implotex	1-850-30	-	LAB000256	–
6	EMI Test Receiver	Rohde & Schwarz	ESW26	101517	LAB000363	2021-02-05 → 2022-02-05
7	Semi-Anechoic Chamber (SAC)	Albatross Projects GmbH	SAC 5 (Babylon 5)	20168.PRB	LAB000235	2020-08-24 → 2021-08-24
8	Measurement Software	Rohde & Schwarz	EMC32 V11.00.10	–	LAB000226	–
9	Turntable	matur GmbH	TT2.0-2t	TT2.0-2t/921	LAB000225	–
10	Antenna Mast	matur GmbH	BAM4.5-P	BAM4.5-P/272	LAB000223	–
11	Controller	matur GmbH	FCU 3.0	10082	LAB000222	–
12	Power Supply	Elektro-Automatik GmbH & Co. KG	PS 2042-10 B	2878350292	LAB000191	–
13	Pre-Amplifier	Schwarzbeck Mess-Elektronik OHG	BBV 9718 C	84	LAB000169	–
14	Open Switch and Control Platform	Rohde & Schwarz	OSP200 Base Unit 2HU	101748	LAB000149	–
15	Antenna	Rohde & Schwarz	HF907	102898	LAB000124	2020-04-23 → 2023-04-23
16	HP-filter	AtlantRF	–	–	LAB000382	–

8.3 Radiated measurements > 18 GHz

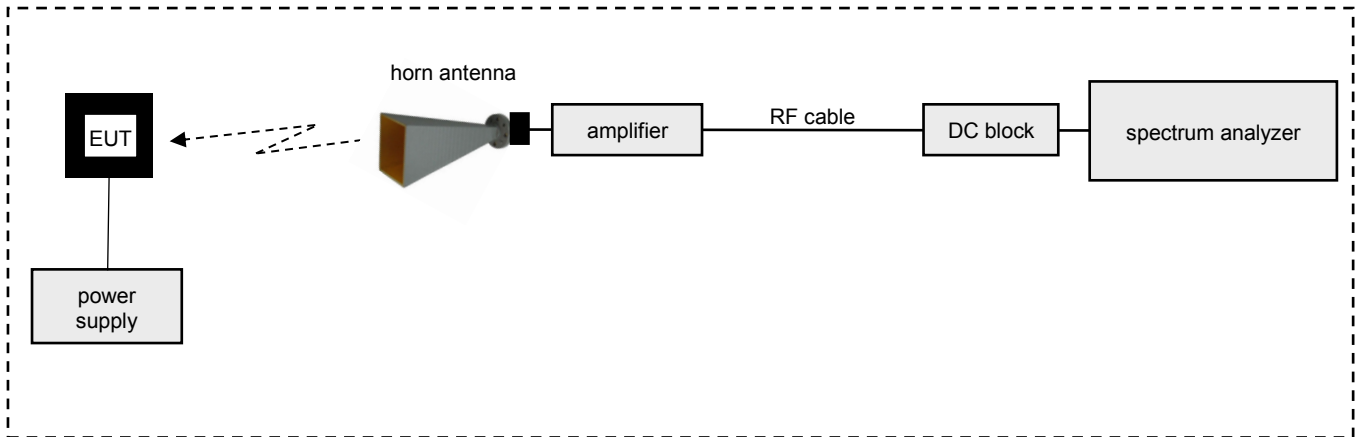

List of test equipment used:

No.	Equipment	Manufacturer	Type	Serial No.	INV. No.	Last / Next Calibration
1	Test table	innco systems GmbH	PT0707-RH light	-	LAB000303	-
2	WG-Coax-Adapter	Flann Microwave Ltd	20093-TF30 UBR220	273374	LAB000181	-
3	Coaxial Cable	Huber & Suhner	SF101/1.5m	503987/1	LAB000165	-
4	Antenna	Flann Microwave Ltd	20240-20	266403	LAB000128	2020-06-29 → 2023-06-29
5	Spectrum Analyser	Rohde & Schwarz	FSW43	101391	LAB000289	2021-07-02 → 2022-07-02

8.4 Conducted measurements WLAN test system R&S TS 8997

The EUT's RF signal is coupled out by the antenna connector which is supplied by the manufacturer. The losses for all signal paths are first checked within a calibration. The measurement readings on the signalling unit/spectrum analyzer are corrected by the specific test set-up loss. The attenuator, power divider, signalling unit and the spectrum analyzer are impedance matched on 50 Ohm.

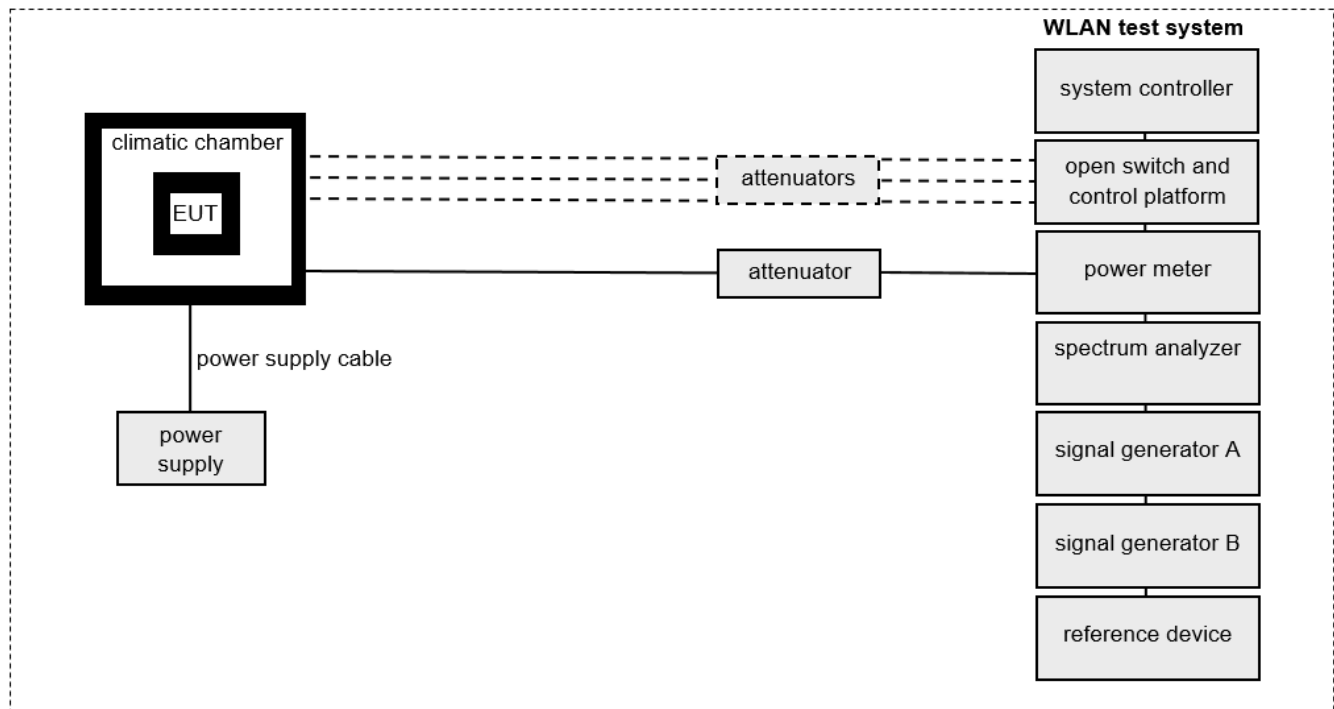

EMC32/WMS32 software version: 11.00.00

List of test equipment used:

No.	Equipment	Manufacturer	Type	Serial No.	INV. No.	Last / Next Calibration
1	TS8997-Rack	Rohde & Schwarz	TS8997-Rack	100829	LAB000322	–
2	Open Switch and Control Platform	Rohde & Schwarz	OSP-B157WX	101247	LAB000280	–
3	Open Switch and Control Platform	Rohde & Schwarz	OSP-B157W8	100982	LAB000279	–
4	Spectrum Analyser	Rohde & Schwarz	FSV40	101403	LAB000278	2021-06-15 → 2022-06-15
5	Signal Generator	Rohde & Schwarz	SMBV100A	258240	LAB000277	2021-06-02 → 2022-06-02
6	Signal Generator	Rohde & Schwarz	SMB100A-20	178175	LAB000276	2021-05-27 → 2022-05-27
7	Radio Communication Tester	Rohde & Schwarz	CMW270	101479	LAB000275	–
8	Controller	Hewlett Packard	ATS-Z230	101379	LAB000274	–
9	Power Supply	EA	PS 2042-10 B	2878350263	LAB000190	–

9 MEASUREMENT UNCERTAINTIES

Radio frequency	$\leq \pm 1 \times 10^{-7}$
RF power, conducted	$\leq \pm 0.75$ dB
Power spectral density	$\leq \pm 3$ dB
Maximum frequency deviation	$\leq \pm 5$ %
Deviation limitation Duty Cycle, Tx-sequence, Tx-gap	$\leq \pm 5$ %
Occupied channel bandwidth	$\leq \pm 5$ %
Conducted spurious emission of transmitter	$\leq \pm 4$ dB
Conducted emission of receivers	$\leq \pm 4$ dB
Radiated emission of transmitter	$\leq \pm 6$ dB
Radiated emission of receiver	$\leq \pm 6$ dB
Temperature	$\leq \pm 2.5$ °C
Humidity	$\leq \pm 10$ %

The indicated expanded measurement uncertainty corresponds to the standard measurement uncertainty for the measurement results multiplied by the coverage factor $k = 2$. It was determined in accordance with EA-4/02 M:2013. The true value is located in the corresponding interval with a probability of 95 %.

End of Test Report

Annex A

Test results of EUT

part of / in addition to

Test report no.: 21086129-23009-1

Tested by
(name, function, signature)

Piotr Sardyko
Deputy Head of Laboratory RF

signature

Approved by
(name, function, signature)

Dr.-Ing. Harald Ansorge
Managing Director

signature

1 TABLE OF CONTENTS

1	TABLE OF CONTENTS	2
2	TEST RESULTS	3
2.1	Variant ID #28	3
2.2	Variant ID #33	21
2.3	Variant ID #39	32
2.4	Variant ID #43	50
2.5	Variant ID #48	62
3	Revision History	73

2 TEST RESULTS

2.1 Variant ID #28

DUT Information

DUT Name: prePV 28
 Manufacturer: Mitsubishi Electric Corporation
 Serial Number: 65112 (conducted)
 65108 (radiated)

2.1.1 RF Output Power (Conducted Peak Power)

Test according to FCC title 47 part 15 §15.247(b), KDB 558074 D01 DTS Meas Guidance v05r02 and ANSI C63.10-2013 11.9.2.3.2

Measurement uncertainty calculated in accordance with ETSI TR 100 028-1.
 Expanded Combined Uncertainty of absolute Level Measurement (K=2) < 1 dB

DUT Information

DUT Name: prePV 28
 Manufacturer: Mitsubishi Electric Corporation
 Serial Number: 65112 (conducted)

Plot 1: Mode 1, AVGPM-G Gated Average Power Measurement, low channel

Result

DUT Frequency (MHz)	Gated RMS (dBm)	Limit Max (dBm)	Gated EIRP (dBm)	DutyCycle (%)	Result
2412.000000	13.6	30.0	13.6	98.238	PASS

Gated Trace

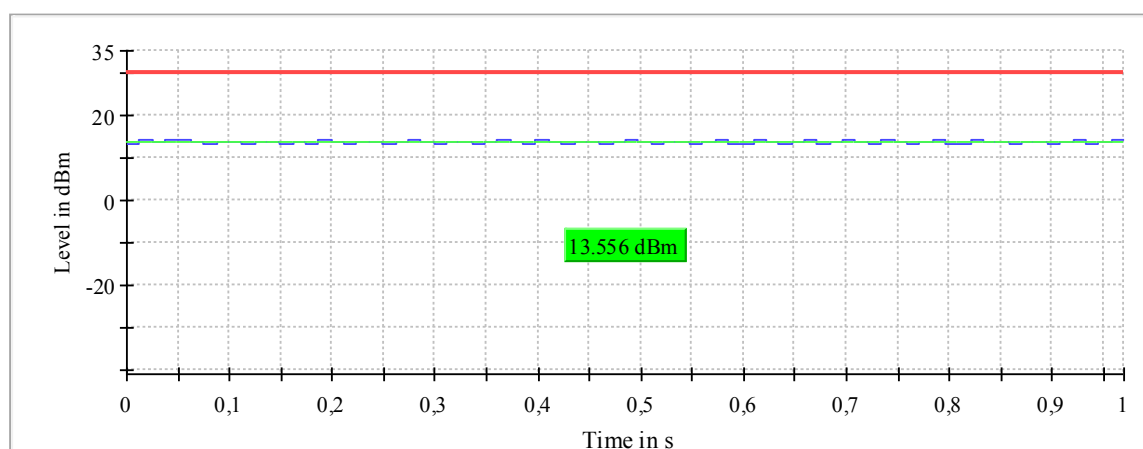

— Gated Trace — Overall — Limit

Plot 2: Mode 1, AVGPM-G Gated Average Power Measurement, mid channel

Result

DUT Frequency (MHz)	Gated RMS (dBm)	Limit Max (dBm)	Gated EIRP (dBm)	DutyCycle (%)	Result
2442.000000	13.2	30.0	13.2	97.058	PASS

Gated Trace

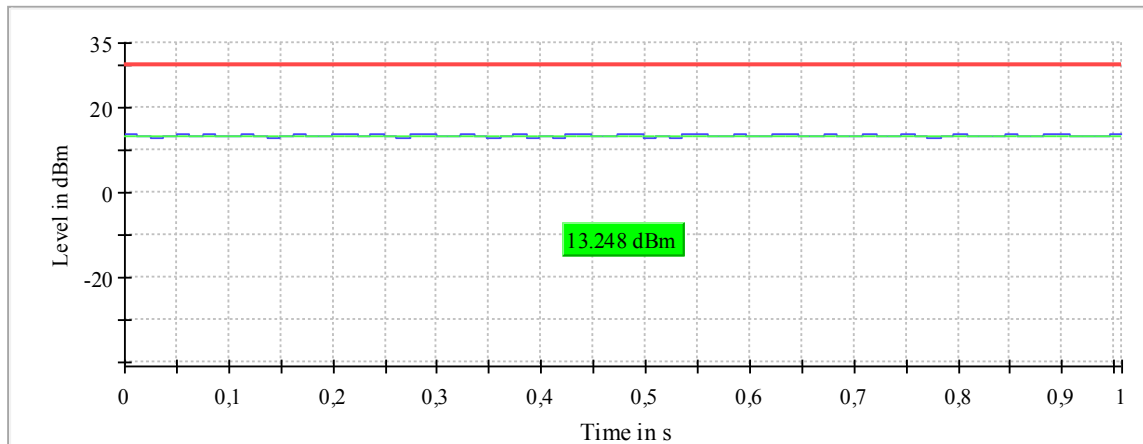

— Gated Trace — Overall — Limit

Plot 3: Mode 1, AVGPM-G Gated Average Power Measurement, high channel

Result

DUT Frequency (MHz)	Gated RMS (dBm)	Limit Max (dBm)	Gated EIRP (dBm)	DutyCycle (%)	Result
2472.000000	13.1	30.0	13.1	98.591	PASS

Gated Trace

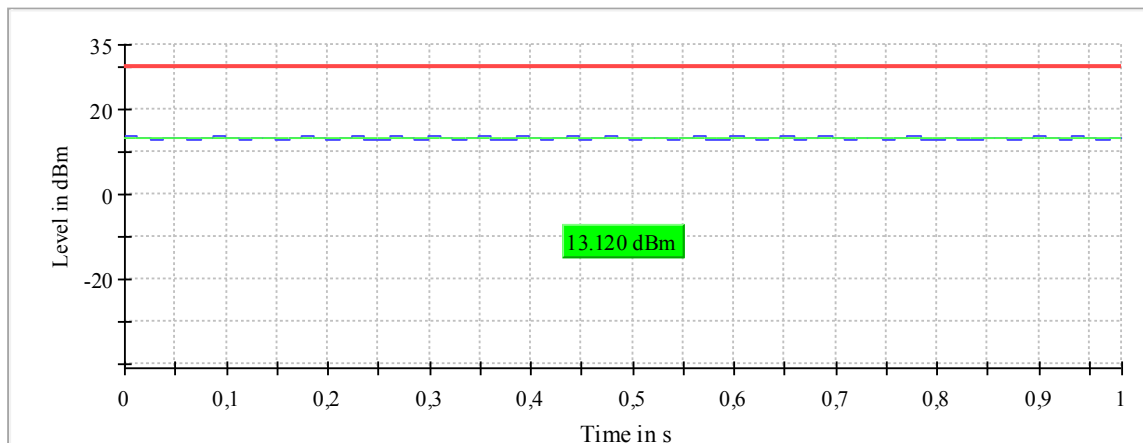

— Gated Trace — Overall — Limit

Annex A of TR no.: 21086129-23009-1

Plot 4: Mode 2, AVGPM-G Gated Average Power Measurement, low channel

Result

DUT Frequency (MHz)	Gated RMS (dBm)	Limit Max (dBm)	Gated EIRP (dBm)	DutyCycle (%)	Result
2412.000000	10.9	30.0	10.9	90.208	PASS

Gated Trace

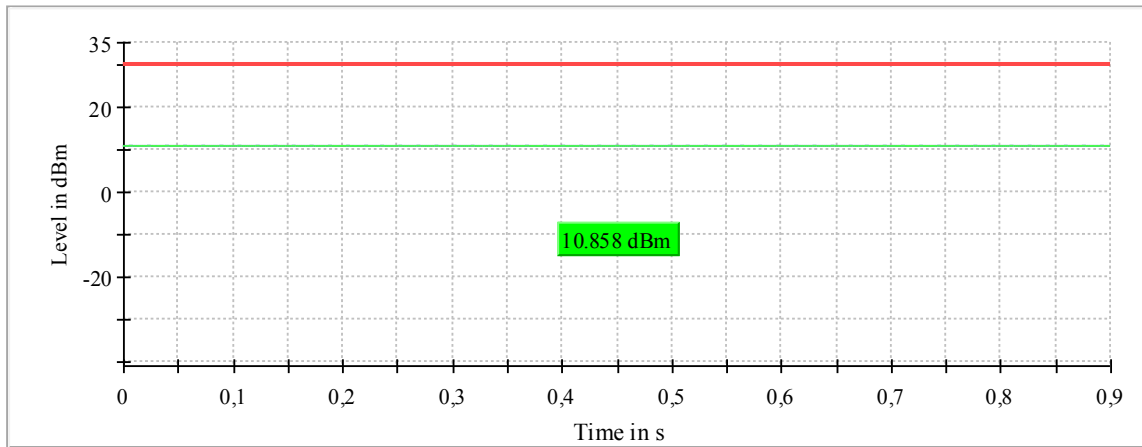

— Gated Trace — Overall — Limit

Plot 5: Mode 2, AVGPM-G Gated Average Power Measurement, mid channel

Result

DUT Frequency (MHz)	Gated RMS (dBm)	Limit Max (dBm)	Gated EIRP (dBm)	DutyCycle (%)	Result
2442.000000	10.6	30.0	10.6	91.789	PASS

Gated Trace

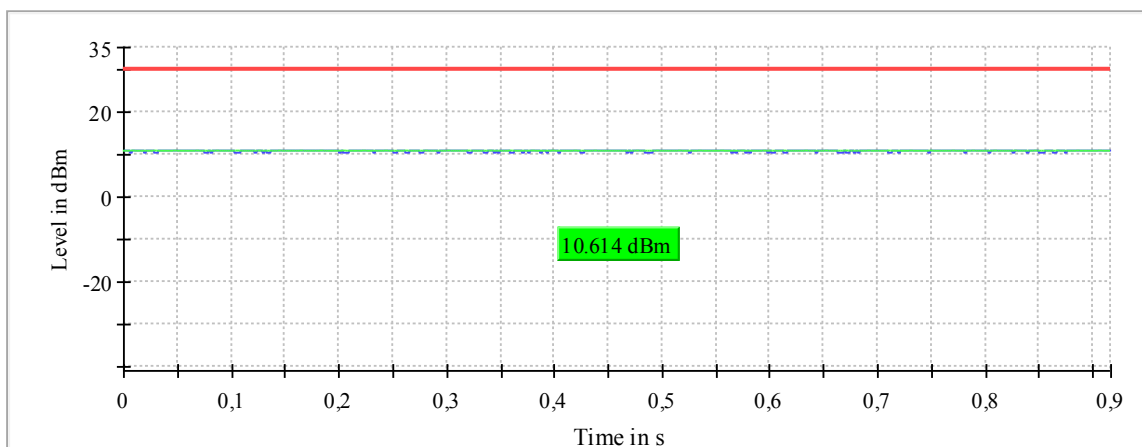

— Gated Trace — Overall — Limit

Annex A of TR no.: 21086129-23009-1

Plot 6: Mode 2, AVGPM-G Gated Average Power Measurement, high channel

Result

DUT Frequency (MHz)	Gated RMS (dBm)	Limit Max (dBm)	Gated EIRP (dBm)	DutyCycle (%)	Result
2472.000000	10.5	30.0	10.5	91.457	PASS

Gated Trace

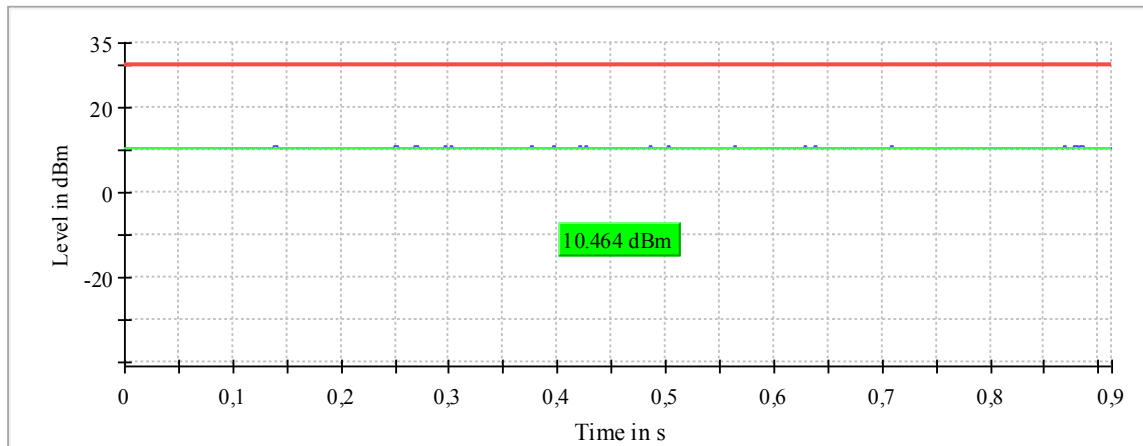

— Gated Trace
 — Overall
 — Limit

Plot 7: Mode 3, AVGPM-G Gated Average Power Measurement, low channel

Result

DUT Frequency (MHz)	Gated RMS (dBm)	Limit Max (dBm)	Gated EIRP (dBm)	DutyCycle (%)	Result
2412.000000	10.7	30.0	10.7	84.071	PASS

Gated Trace

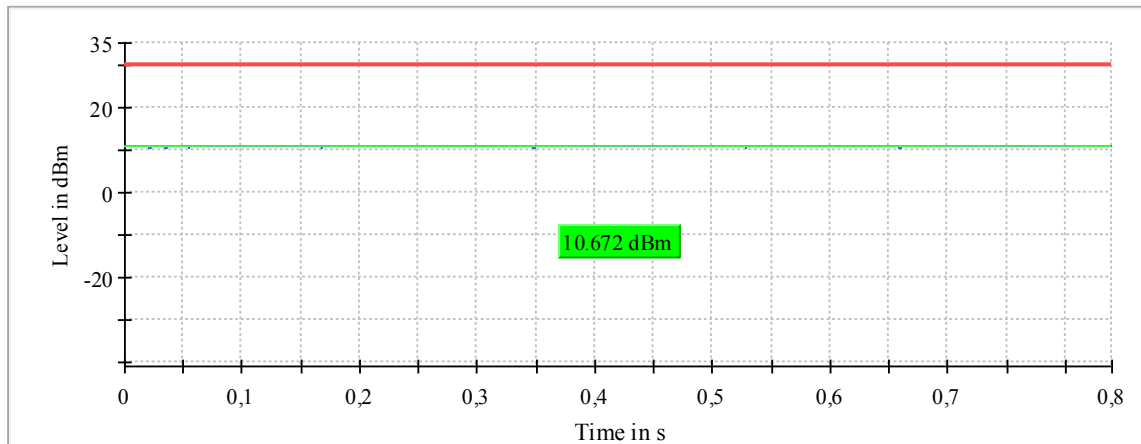

— Gated Trace — Overall — Limit

Plot 8: Mode 3, AVGPM-G Gated Average Power Measurement, mid channel

Result

DUT Frequency (MHz)	Gated RMS (dBm)	Limit Max (dBm)	Gated EIRP (dBm)	DutyCycle (%)	Result
2442.000000	10.4	30.0	10.4	87.293	PASS

Gated Trace

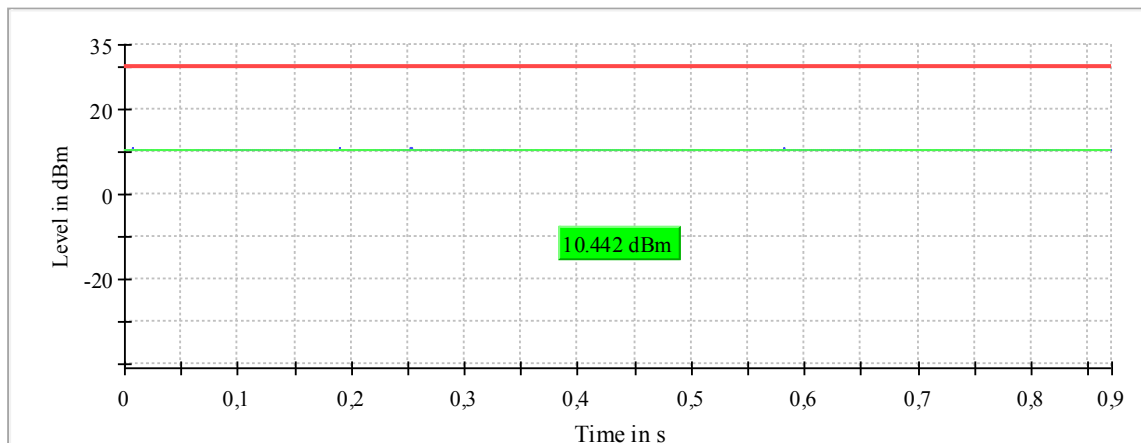

— Gated Trace — Overall — Limit

Plot 9: Mode 3, AVGPM-G Gated Average Power Measurement, high channel

Result

DUT Frequency (MHz)	Gated RMS (dBm)	Limit Max (dBm)	Gated EIRP (dBm)	DutyCycle (%)	Result
2472.000000	10.3	30.0	10.3	84.525	PASS

Gated Trace

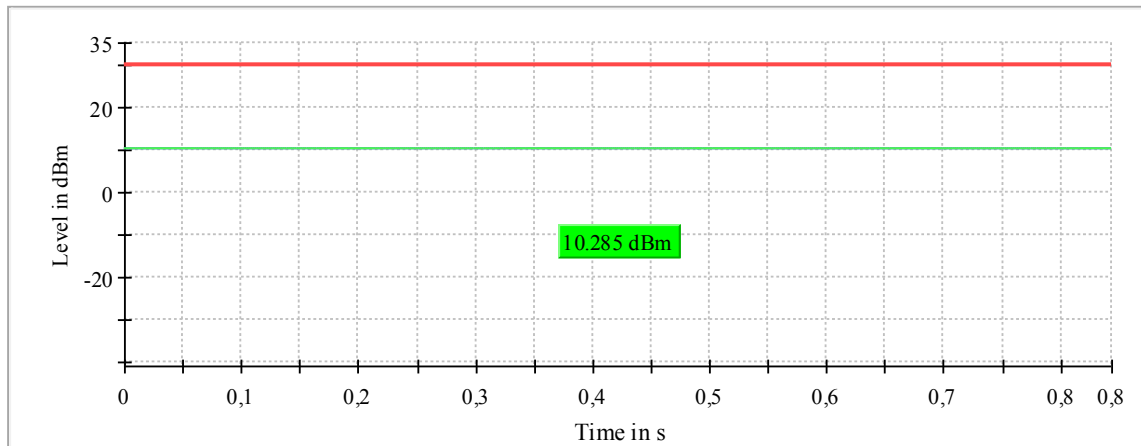

— Gated Trace — Overall — Limit

2.1.2 Radiated Peak Power (Peak EIRP)

Plot 10: Test Mode 1, DBPSK, 1 Mbit/s, Peak EIRP, low channel 1, 2412 MHz

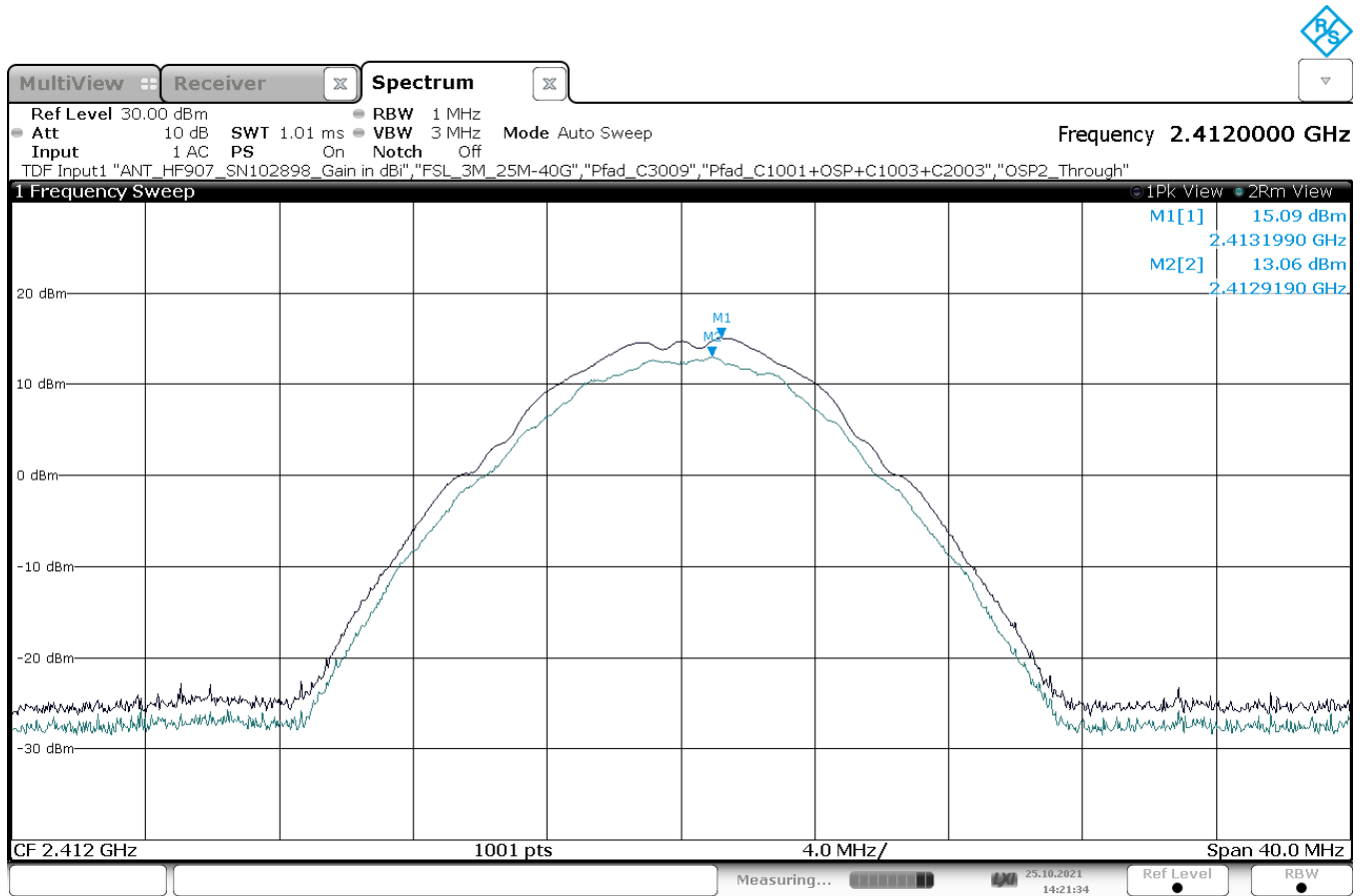

14:21:35 25.10.2021

Plot 11: Test Mode 1, DBPSK, 1 Mbit/s, Peak EIRP, high channel 13, 2472 MHz

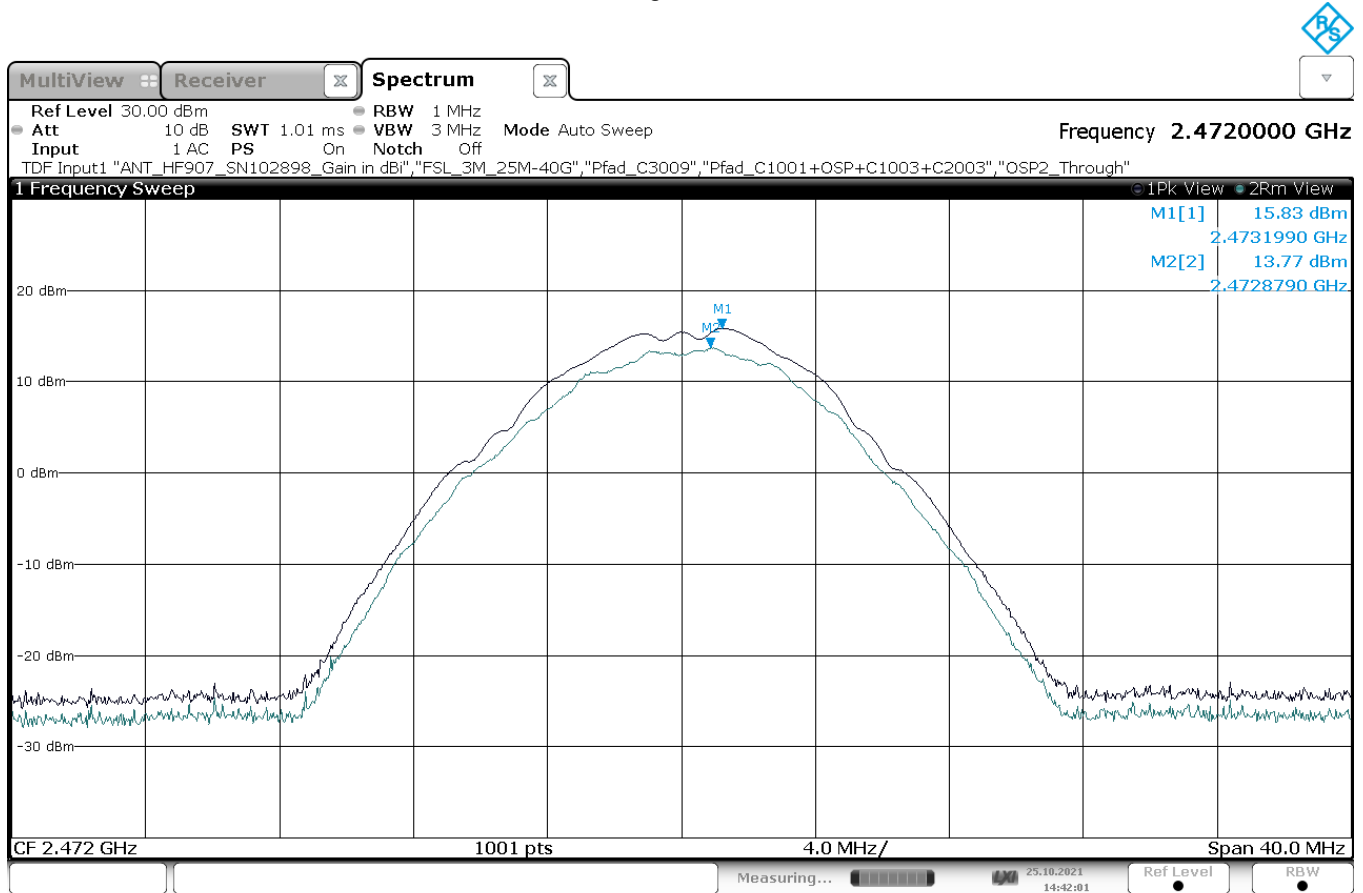

14:42:02 25.10.2021

2.1.3 Band Edge Compliance (BEC), radiated

Plot 12: Mode 1, BEC, low channel 1

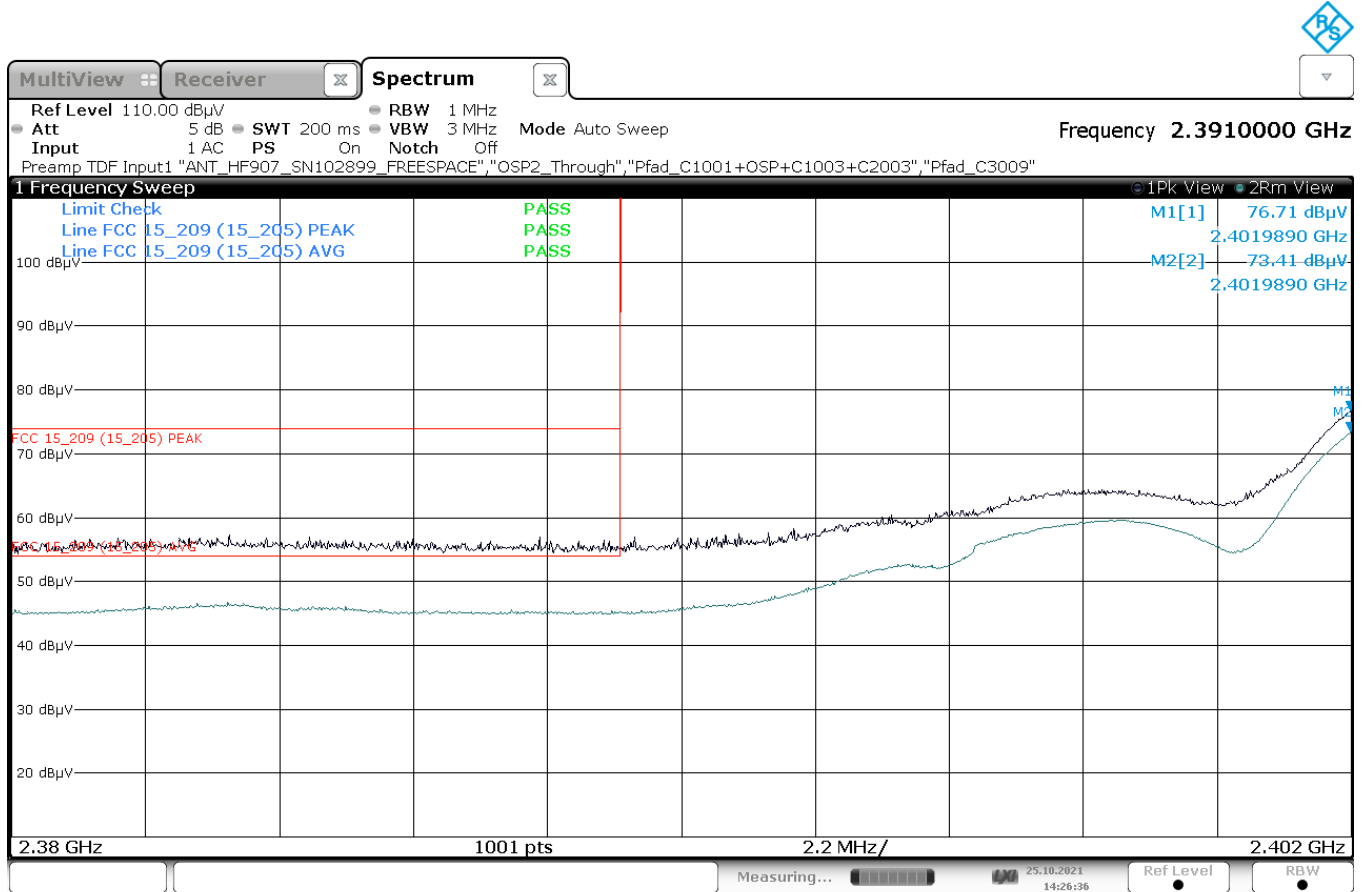

14:26:37 25.10.2021

Plot 13: Mode 1, BEC, high channel 13

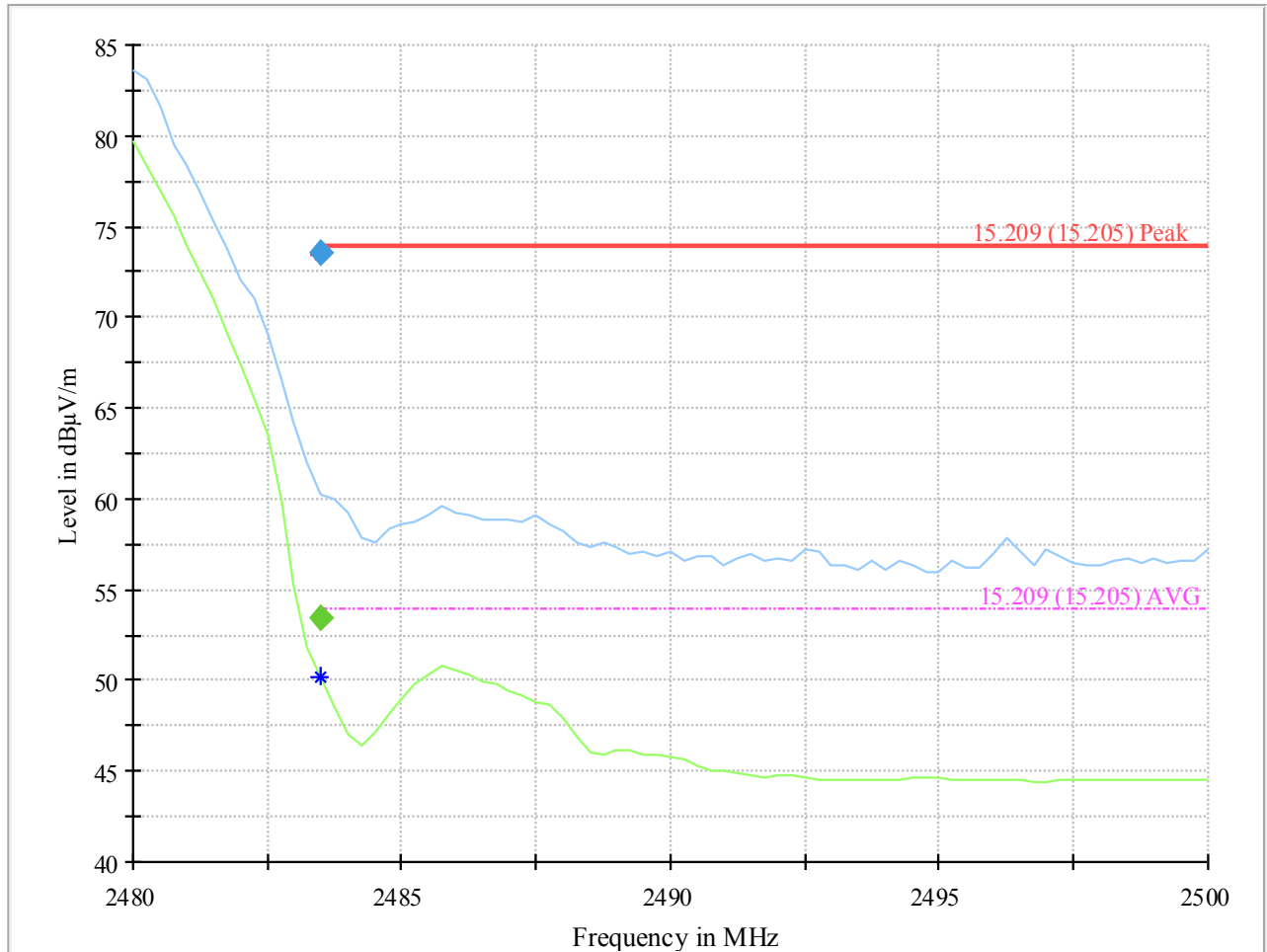

Final_Result

Frequency (MHz)	MaxPeak (dBµV/m)	Average (dBµV/m)	Limit (dBµV/m)	Margin (dB)	Meas. Time (ms)	Bandwidth (kHz)	Height (cm)	Pol
2483.500000	---	53.49	54.00	0.52	100.0	1000.000	150.0	V
2483.500000	73.55	---	74.00	0.45	100.0	1000.000	150.0	V

(continuation of the "Final_Result" table from column 14 ...)

Frequency (MHz)	Azimuth (deg)	Elevation (deg)	Corr. (dB/m)	Comment
2483.500000	48.0	90.0	33.6	16:24:36 - 25.10.2021
2483.500000	-5.0	90.0	33.6	16:23:58 - 25.10.2021

2.1.4 Radiated Spurious Emissions (RSE)

Plot 14: Mode 1, RSE 9 kHz – 30 MHz, low channel, loop antenna

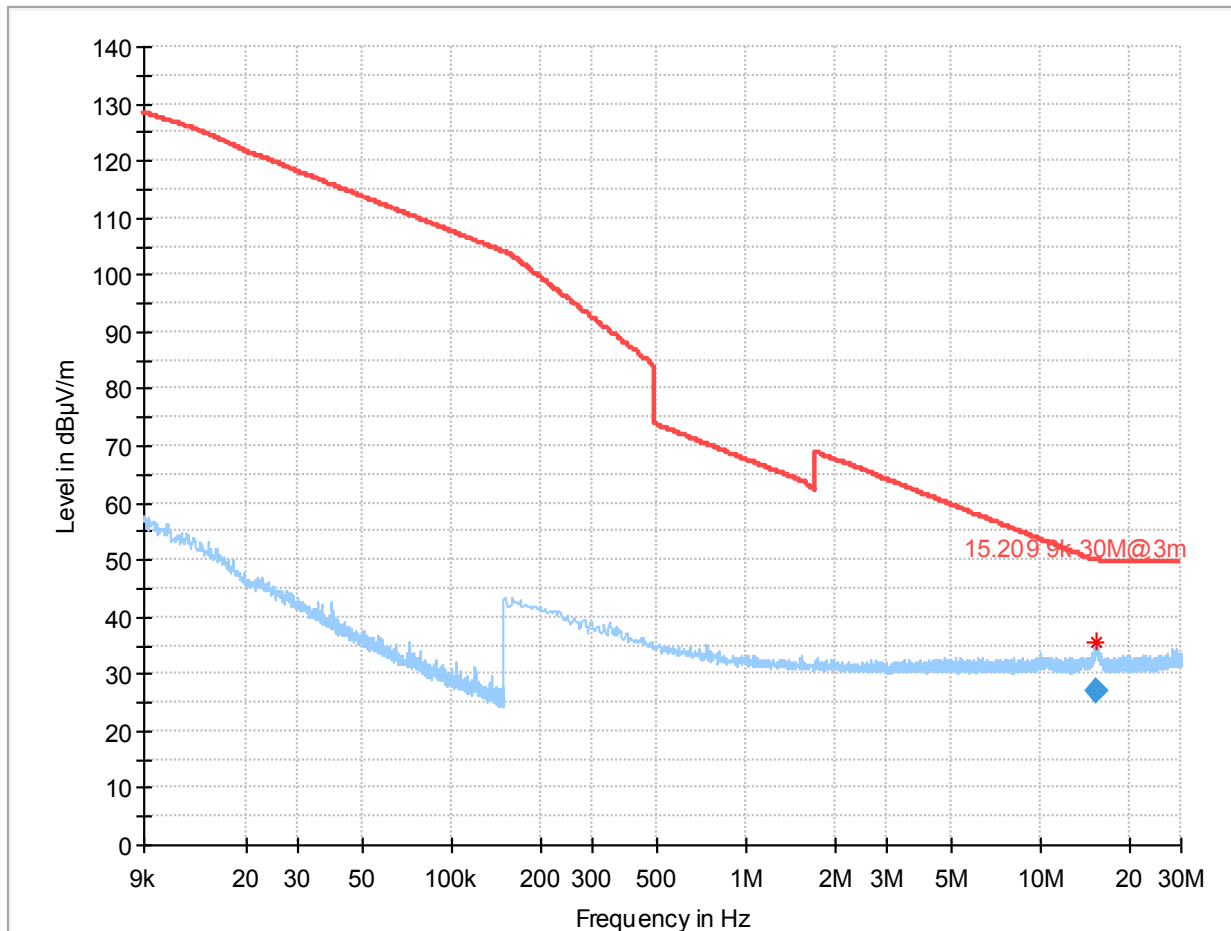

Frequency (MHz)	QuasiPeak (dBµV/m)	Limit (dBµV/m)	Margin (dB)	Meas. Time (ms)	Bandwidth (kHz)	Pol	Azimuth (deg)	Corr. (dB/m)
15.346500	27.09	50.04	22.95	100.0	9.000	H	30.0	20.5

Plot 15: Mode 1, RSE 9 kHz – 30 MHz, high channel, loop antenna

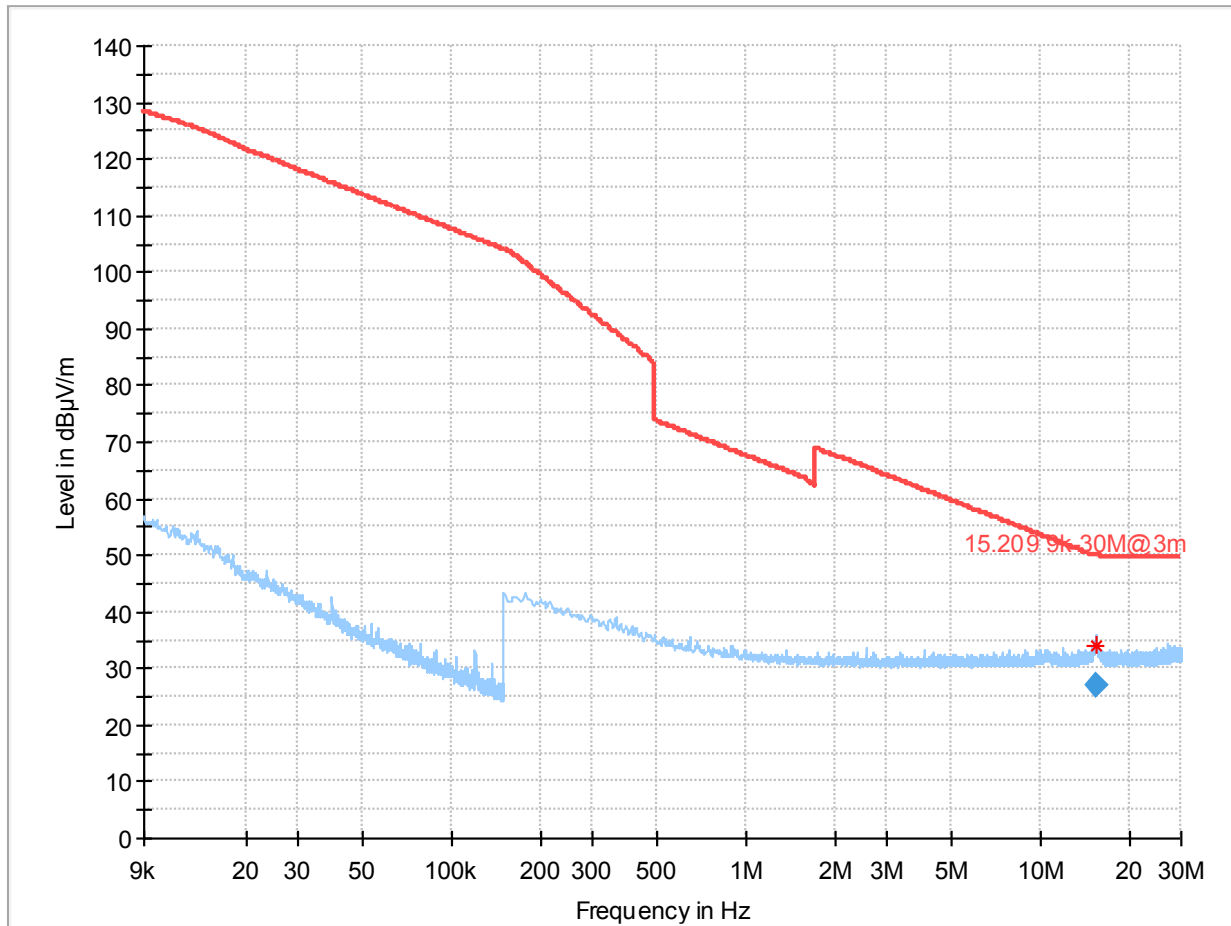

Frequency (MHz)	QuasiPeak (dBµV/m)	Limit (dBµV/m)	Margin (dB)	Meas. Time (ms)	Bandwidth (kHz)	Pol	Azimuth (deg)	Corr. (dB/m)
15.398250	26.94	50.04	23.10	100.0	9.000	V	240.0	20.5

Plot 16: Mode 1, RSE 30 MHz – 1 GHz, low channel, horizontal / vertical polarisation

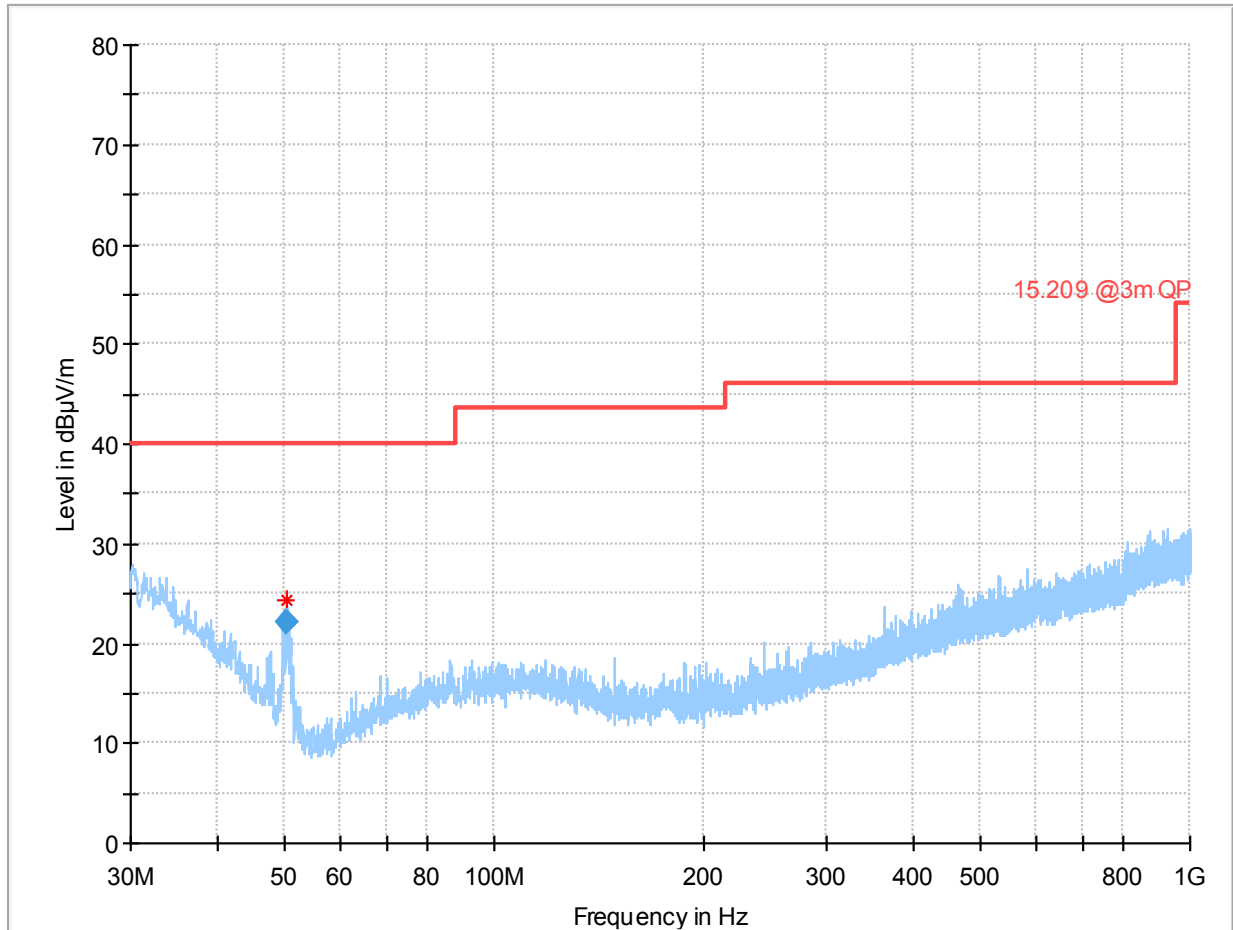

Frequency (MHz)	QuasiPeak (dBµV/m)	Limit (dBµV/m)	Margin (dB)	Meas. Time (ms)	Bandwidth (kHz)	Height (cm)	Pol	Azimuth (deg)
50.467000	22.18	40.00	17.82	100.0	120.000	100.0	V	131.0

Plot 17: Mode 1, RSE 30 MHz – 1 GHz, high channel, horizontal / vertical polarisation

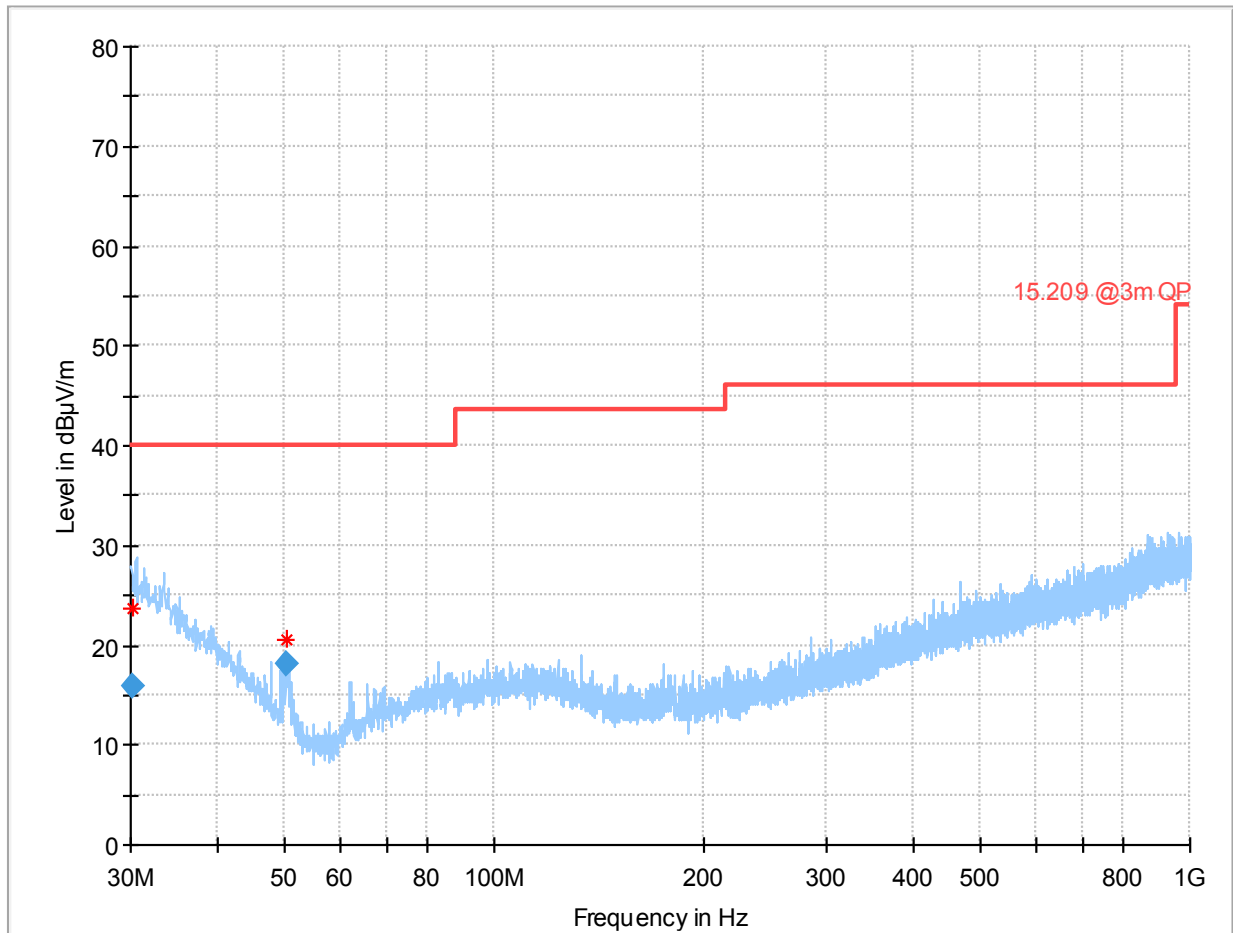

Frequency (MHz)	QuasiPeak (dBµV/m)	Limit (dBµV/m)	Margin (dB)	Meas. Time (ms)	Bandwidth (kHz)	Height (cm)	Pol	Azimuth (deg)
30.132000	15.90	40.00	24.10	100.0	120.000	150.0	V	270.0
50.474500	18.02	40.00	21.98	100.0	120.000	103.0	V	134.0

Annex A of TR no.: 21086129-23009-1

Plot 18: Mode 1, RSE 1 GHz – 3 GHz, low channel, horizontal / vertical polarisation

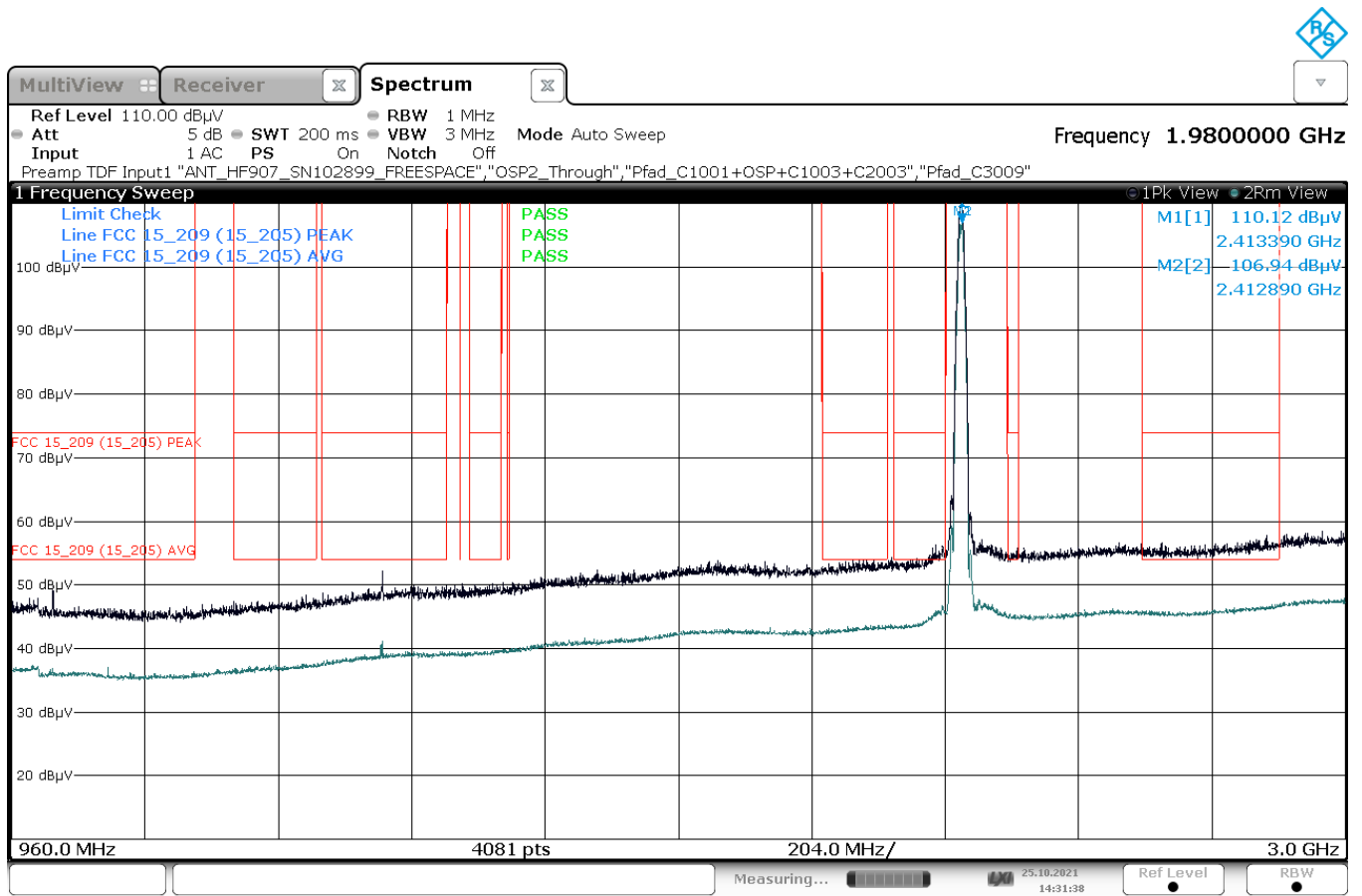

14:31:39 25.10.2021

Plot 19: Mode 1, RSE 1 GHz – 3 GHz, high channel, horizontal / vertical polarisation

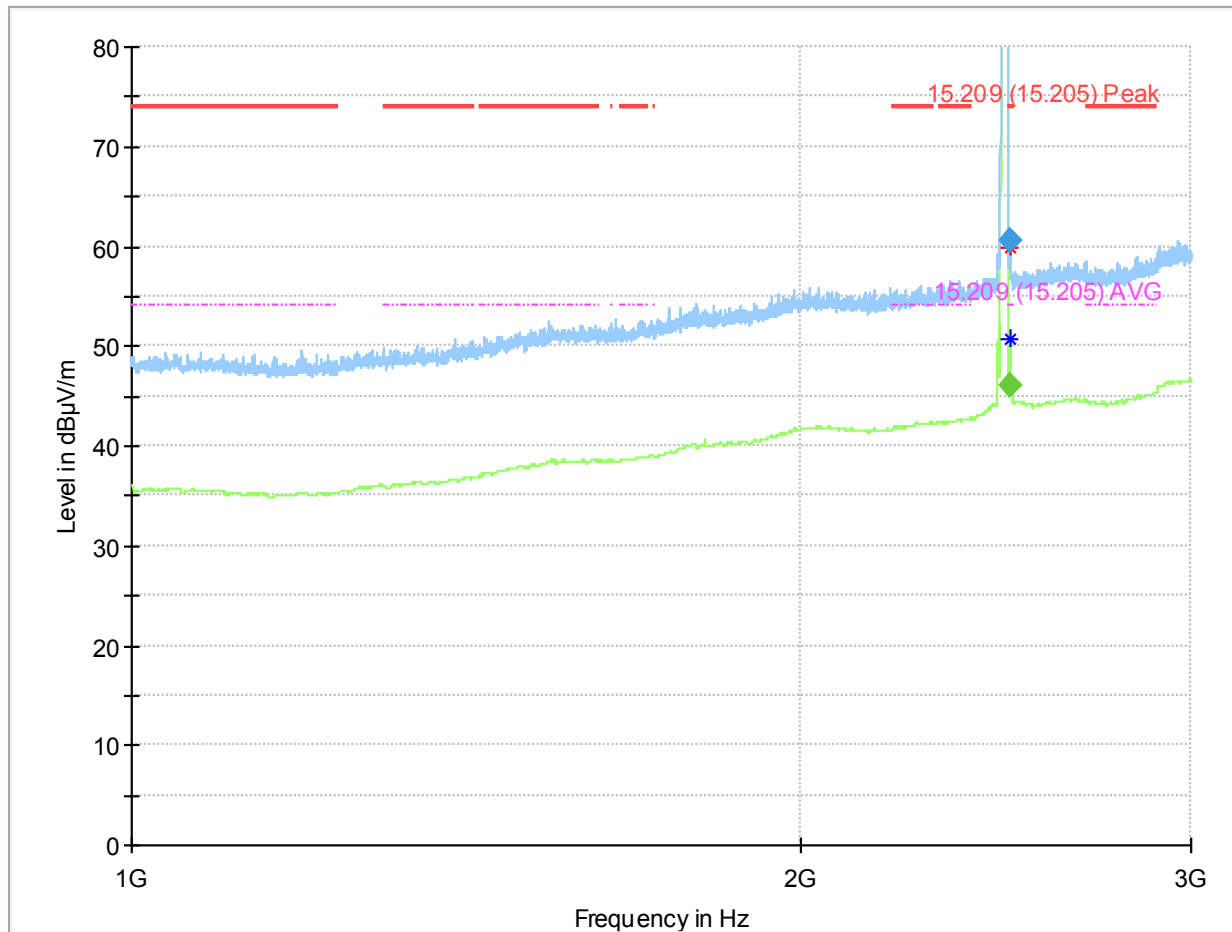

Final_Result

Frequency (MHz)	MaxPeak (dBµV/m)	Average (dBµV/m)	Limit (dBµV/m)	Margin (dB)	Meas. Time (ms)	Bandwidth (kHz)	Height (cm)	Pol
2485.750000	---	45.92	54.00	8.08	100.0	1000.000	150.0	V
2485.750000	60.51	---	74.00	13.49	100.0	1000.000	150.0	V

(continuation of the "Final_Result" table from column 14 ...)

Frequency (MHz)	Azimuth (deg)	Elevation (deg)	Corr. (dB/m)	Comment
2485.750000	48.0	90.0	33.6	16:44:58 - 25.10.2021
2485.750000	-1.0	90.0	33.6	16:44:20 - 25.10.2021

Annex A of TR no.: 21086129-23009-1

Plot 20: Mode 1, RSE 3 GHz – 9 GHz, low channel, horizontal / vertical polarisation

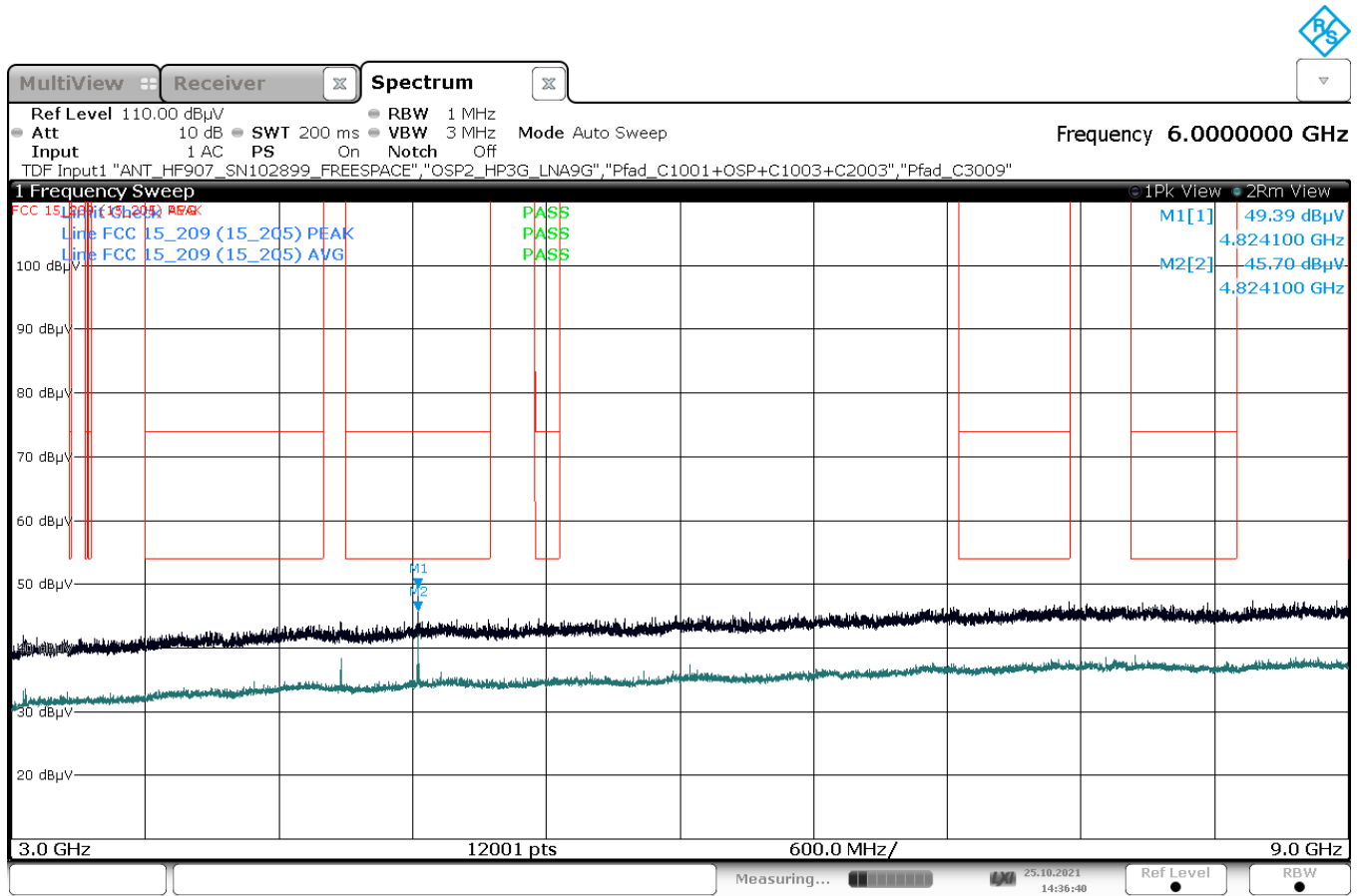

14:36:40 25.10.2021

Annex A of TR no.: 21086129-23009-1

Plot 21: Mode 1, RSE 3 GHz – 9 GHz, high channel, horizontal / vertical polarisation

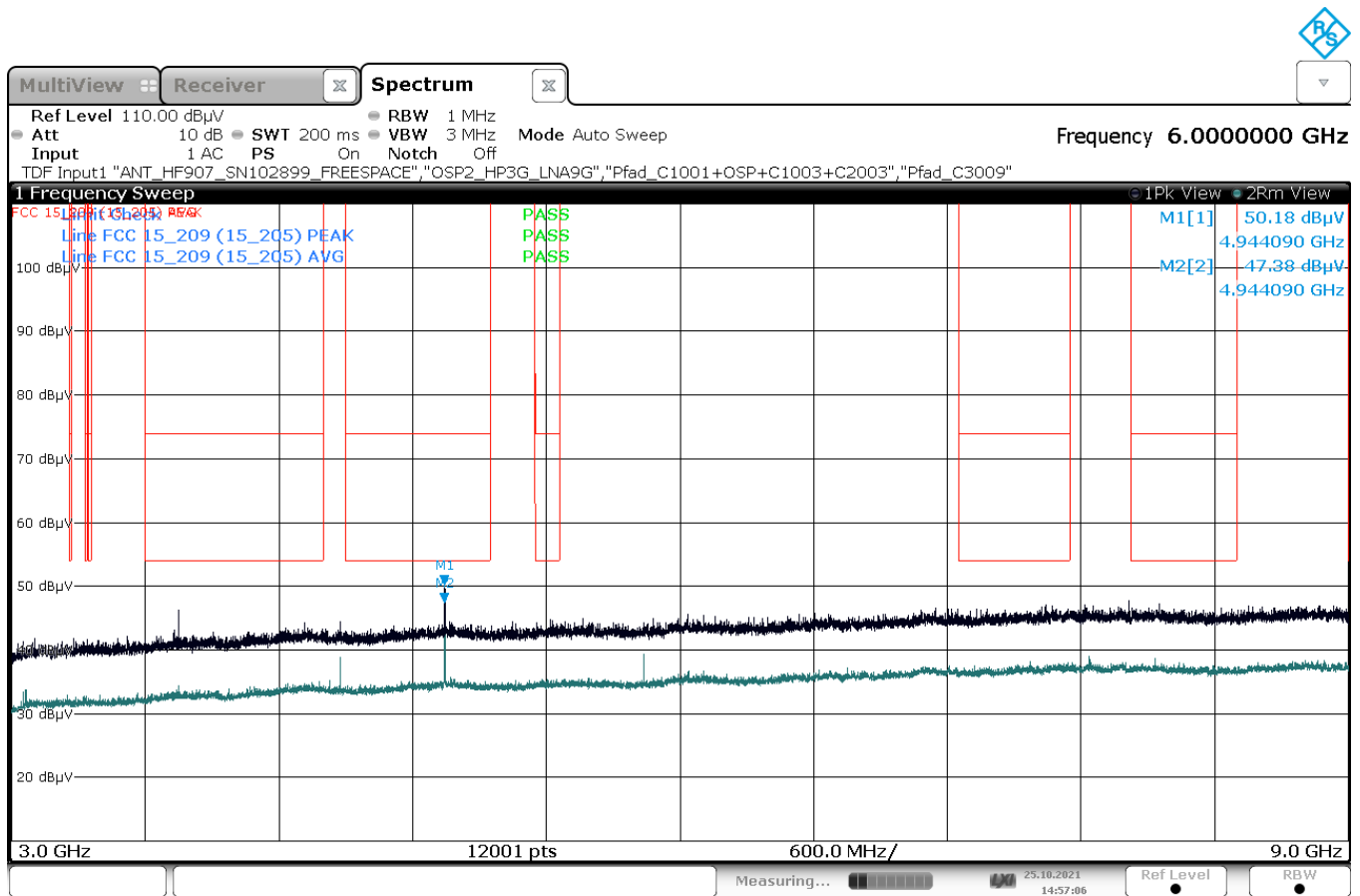

14:57:07 25.10.2021

2.2 Variant ID #33

DUT Information

DUT Name:	prePV 33
Manufacturer:	Mitsubishi Electric Corporation
Serial Number:	66605 (radiated)

2.2.1 RF Output Power (Conducted Peak Power)

See test results of R1LOW-R-SBM DV model (see IBL-Lab test report TR-21065799-20827)

2.2.2 Radiated Peak Power (Peak EIRP)

See test results of R1LOW-R-SBM DV model (see IBL-Lab test report TR-21065799-20827)

2.2.3 Band Edge Compliance (BEC), radiated

Plot 22: Mode 1, BEC, low channel 1

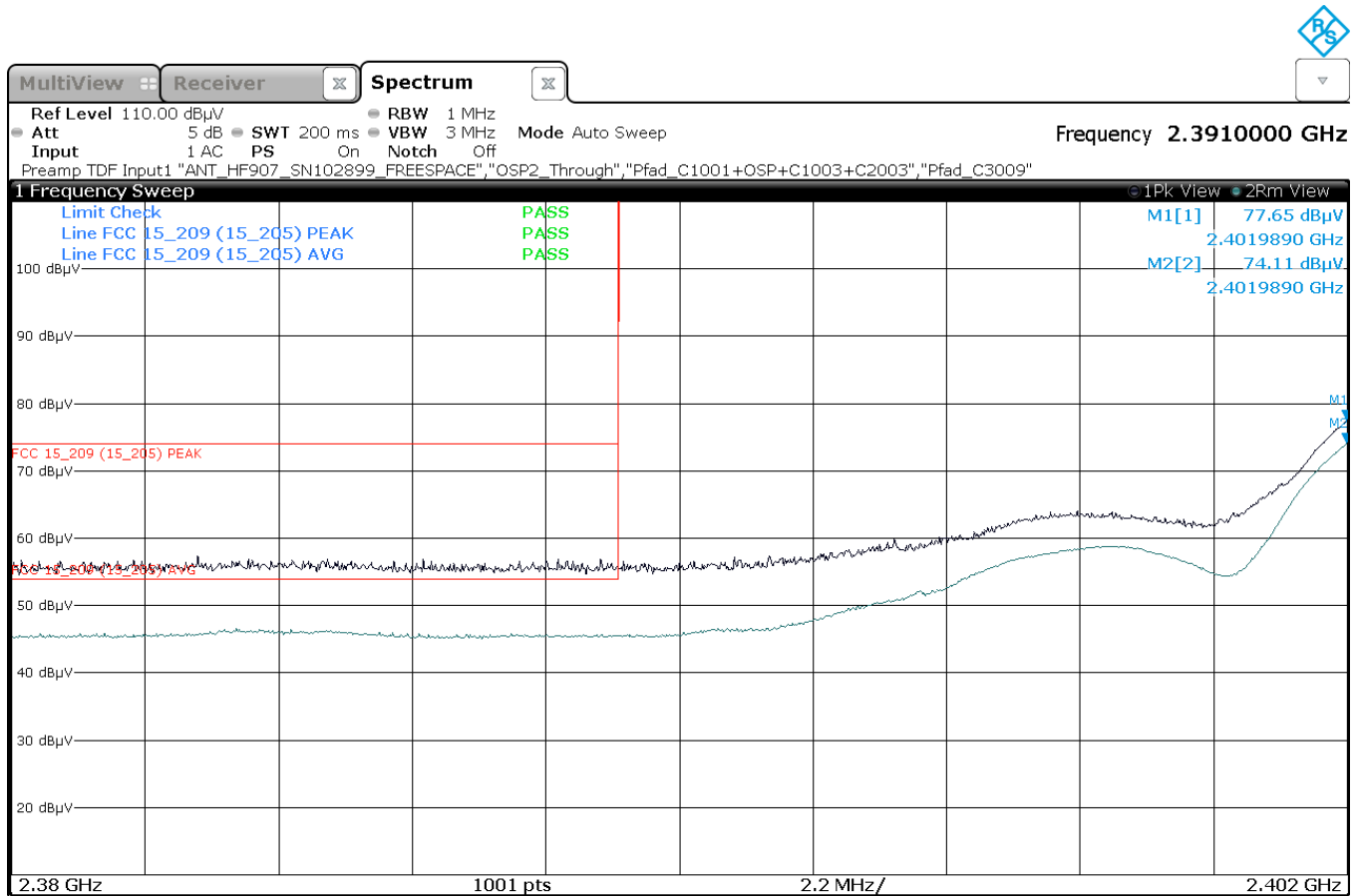

18:30:41 24.10.2021

Plot 23: Mode 1, BEC, high channel 13

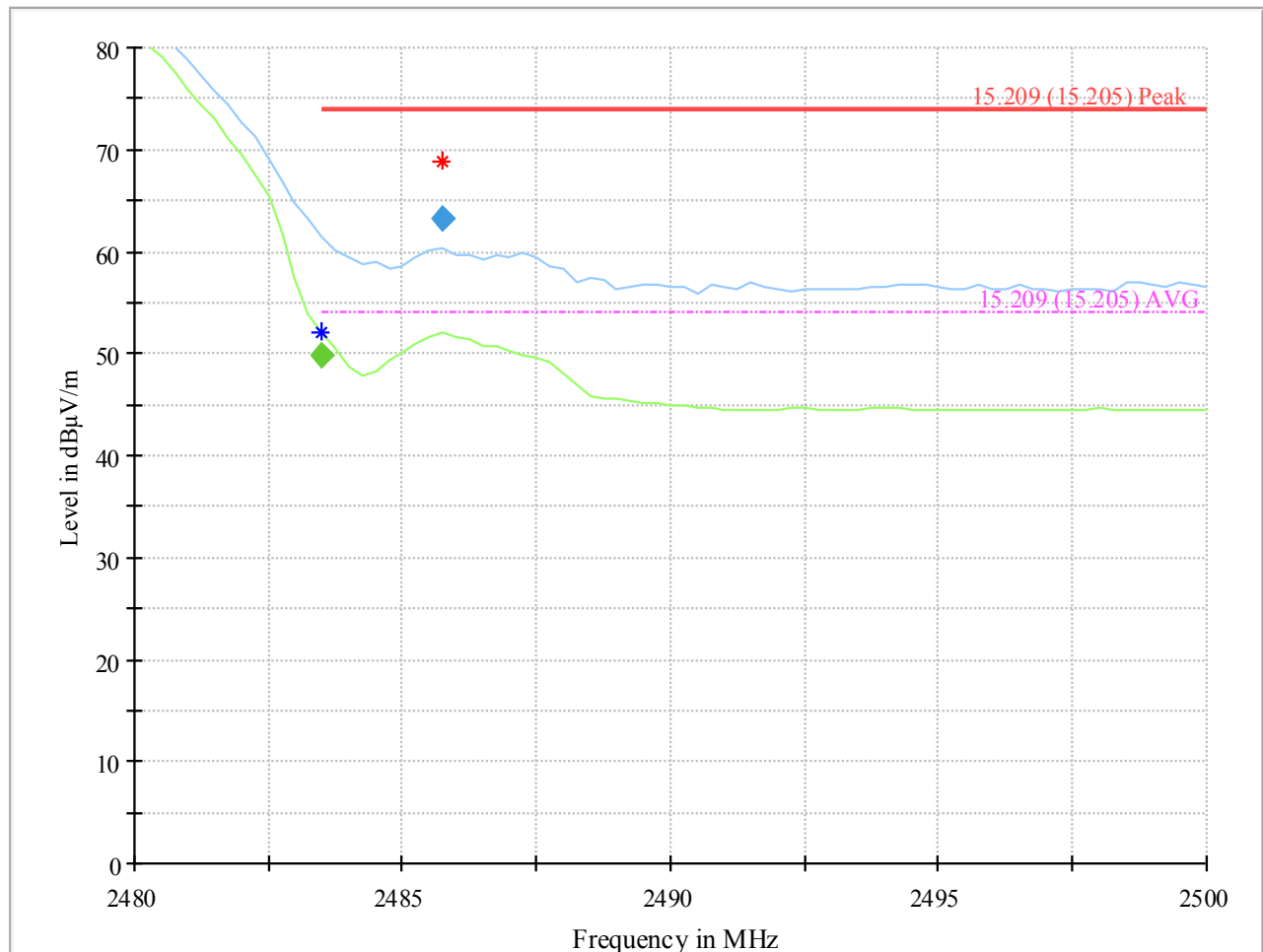

Final_Result

Frequency (MHz)	MaxPeak (dBµV/m)	Average (dBµV/m)	Limit (dBµV/m)	Margin (dB)	Meas. Time (ms)	Bandwidth (kHz)	Height (cm)	Pol
2483.500000	---	49.81	54.00	4.19	100.0	1000.000	150.0	V
2485.750000	63.18	---	74.00	10.82	100.0	1000.000	150.0	V

(continuation of the "Final_Result" table from column 14 ...)

Frequency (MHz)	Azimuth (deg)	Elevation (deg)	Corr. (dB/m)	Comment
2483.500000	3.0	90.0	33.6	20:58:16 - 24.10.2021
2485.750000	-16.0	90.0	33.6	20:57:40 - 24.10.2021

2.2.4 Radiated Spurious Emissions (RSE)

Plot 24: Mode 1, RSE 9 kHz – 30 MHz, low channel, loop antenna

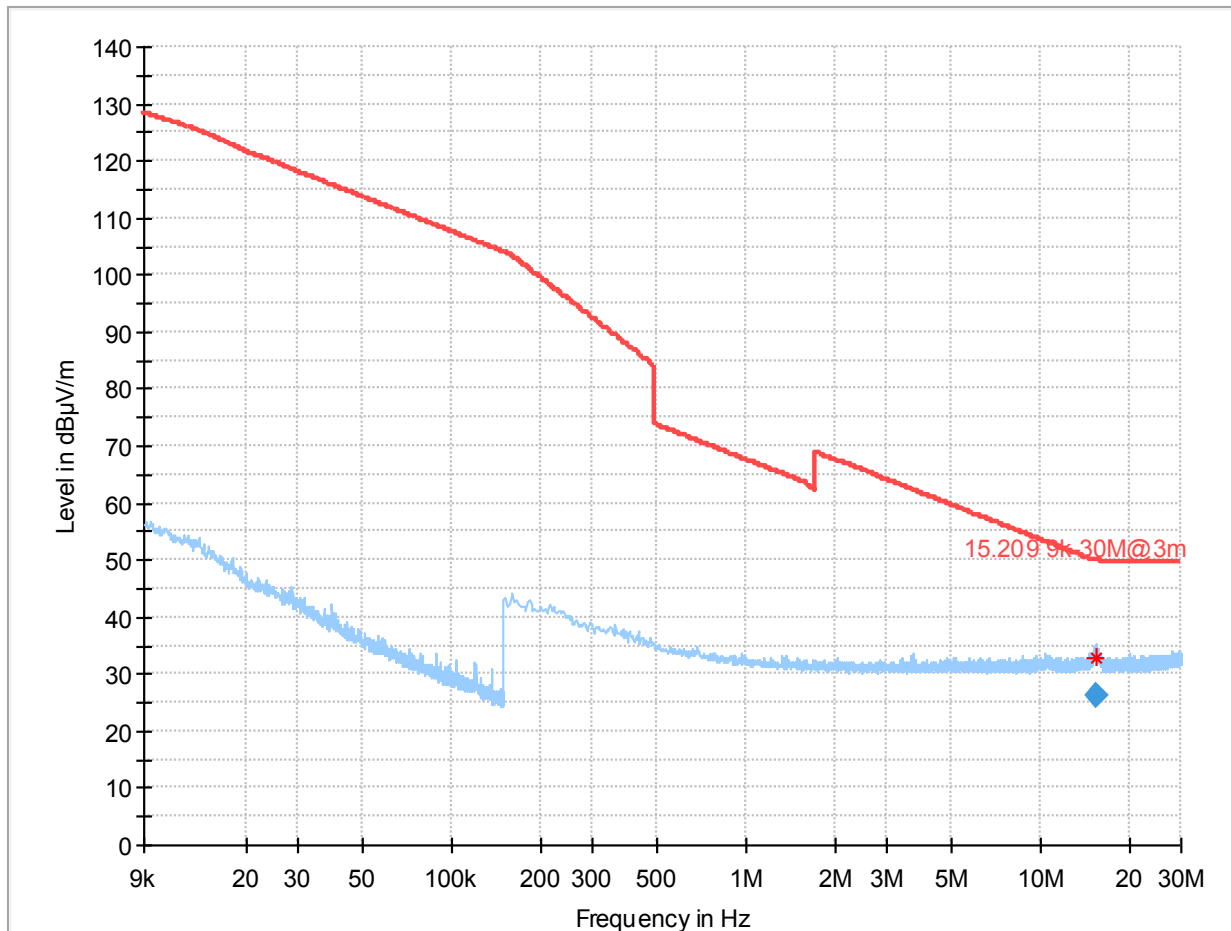

Frequency (MHz)	QuasiPeak (dBµV/m)	Limit (dBµV/m)	Margin (dB)	Meas. Time (ms)	Bandwidth (kHz)	Pol	Azimuth (deg)	Corr. (dB/m)
15.371250	26.35	50.04	23.69	100.0	9.000	H	300.0	20.5

Plot 25: Mode 1, RSE 9 kHz – 30 MHz, high channel, loop antenna

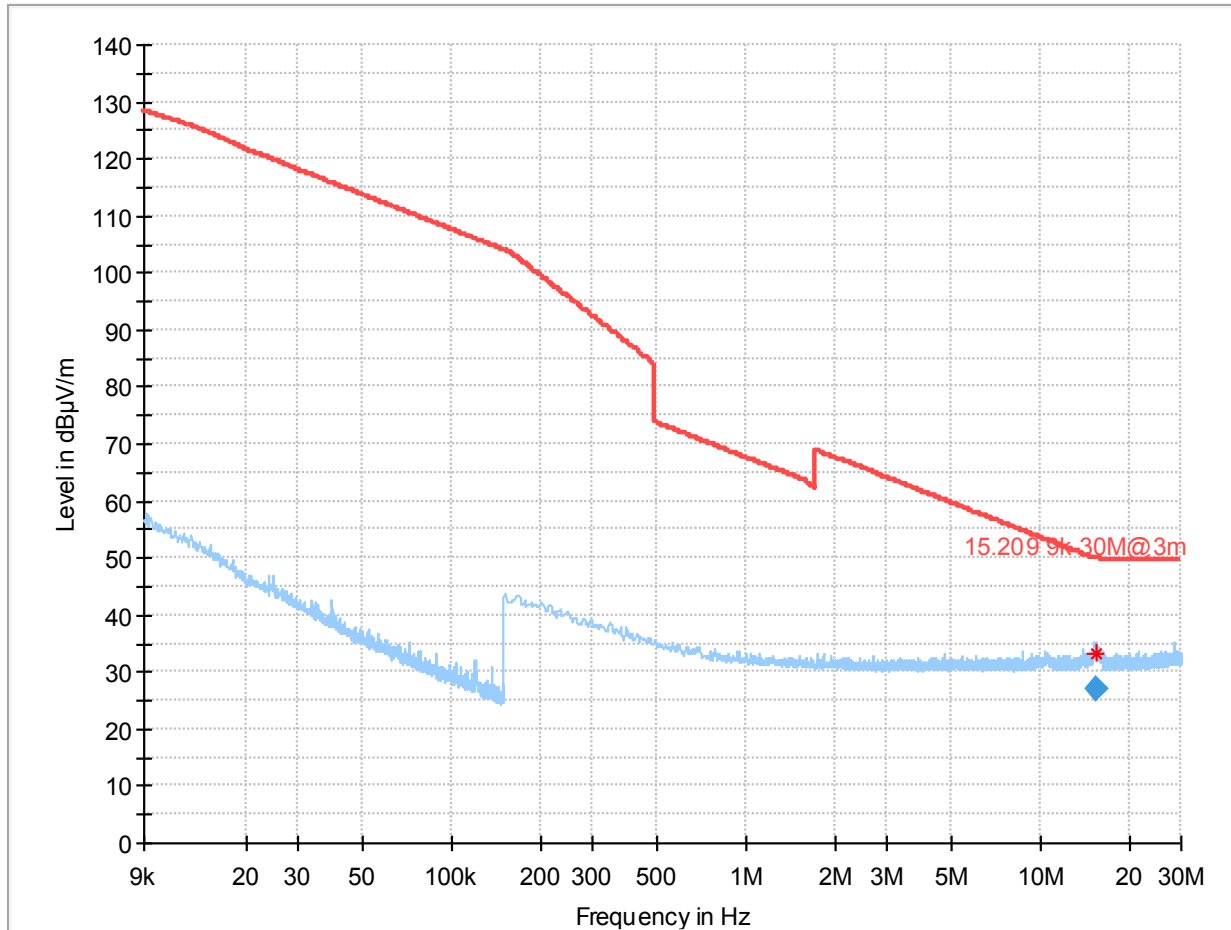

Frequency (MHz)	QuasiPeak (dBµV/m)	Limit (dBµV/m)	Margin (dB)	Meas. Time (ms)	Bandwidth (kHz)	Pol	Azimuth (deg)	Corr. (dB/m)
15.375750	26.83	50.04	23.21	100.0	9.000	H	300.0	20.5

Plot 26: Mode 1, RSE 30 MHz – 1 GHz, low channel, horizontal / vertical polarisation

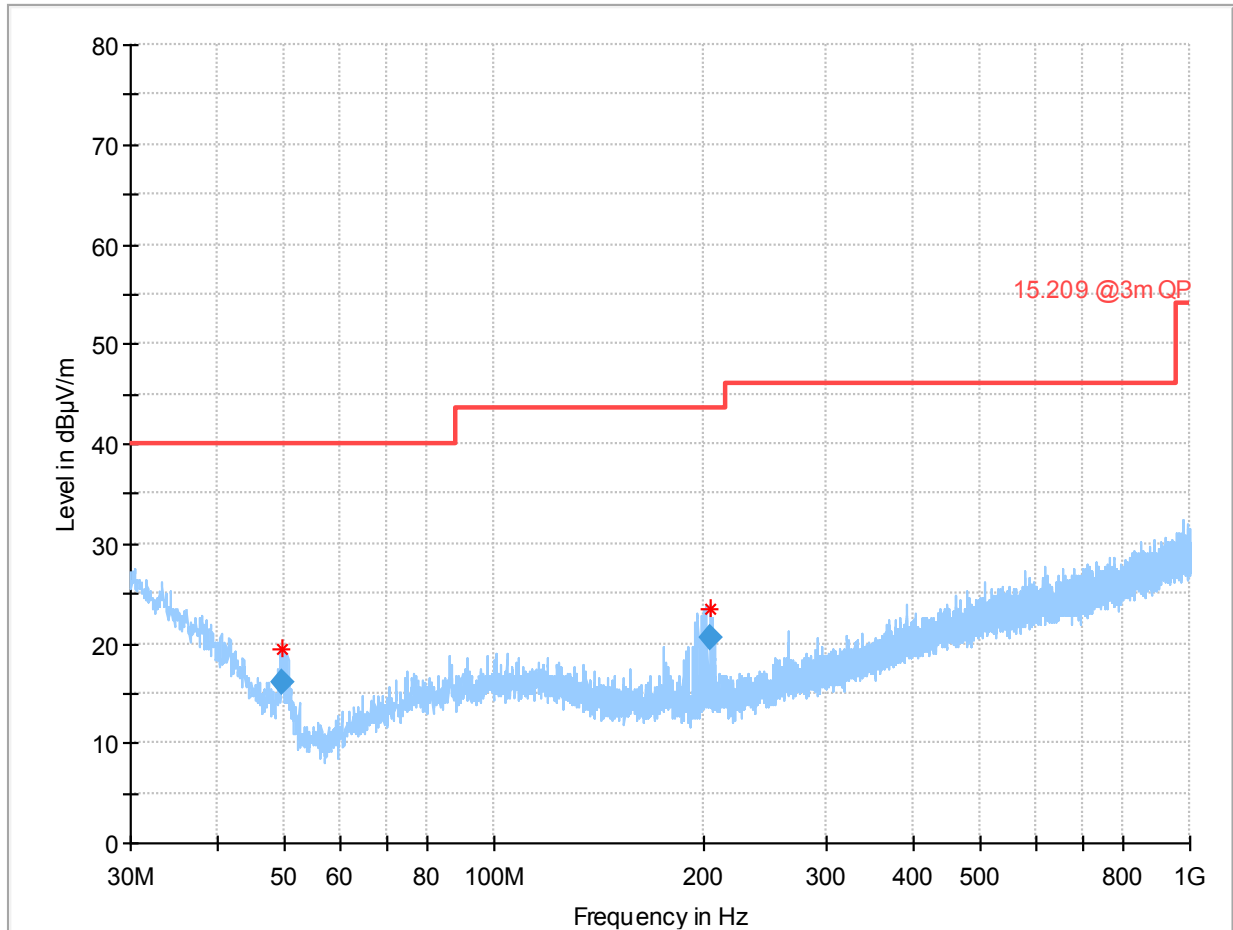

Frequency (MHz)	QuasiPeak (dBµV/m)	Limit (dBµV/m)	Margin (dB)	Meas. Time (ms)	Bandwidth (kHz)	Height (cm)	Pol	Azimuth (deg)
49.706000	16.09	40.00	23.91	100.0	120.000	100.0	V	356.0
204.119500	20.64	43.50	22.86	100.0	120.000	103.0	V	38.0

Plot 27: Mode 1, RSE 30 MHz – 1 GHz, high channel, horizontal / vertical polarisation

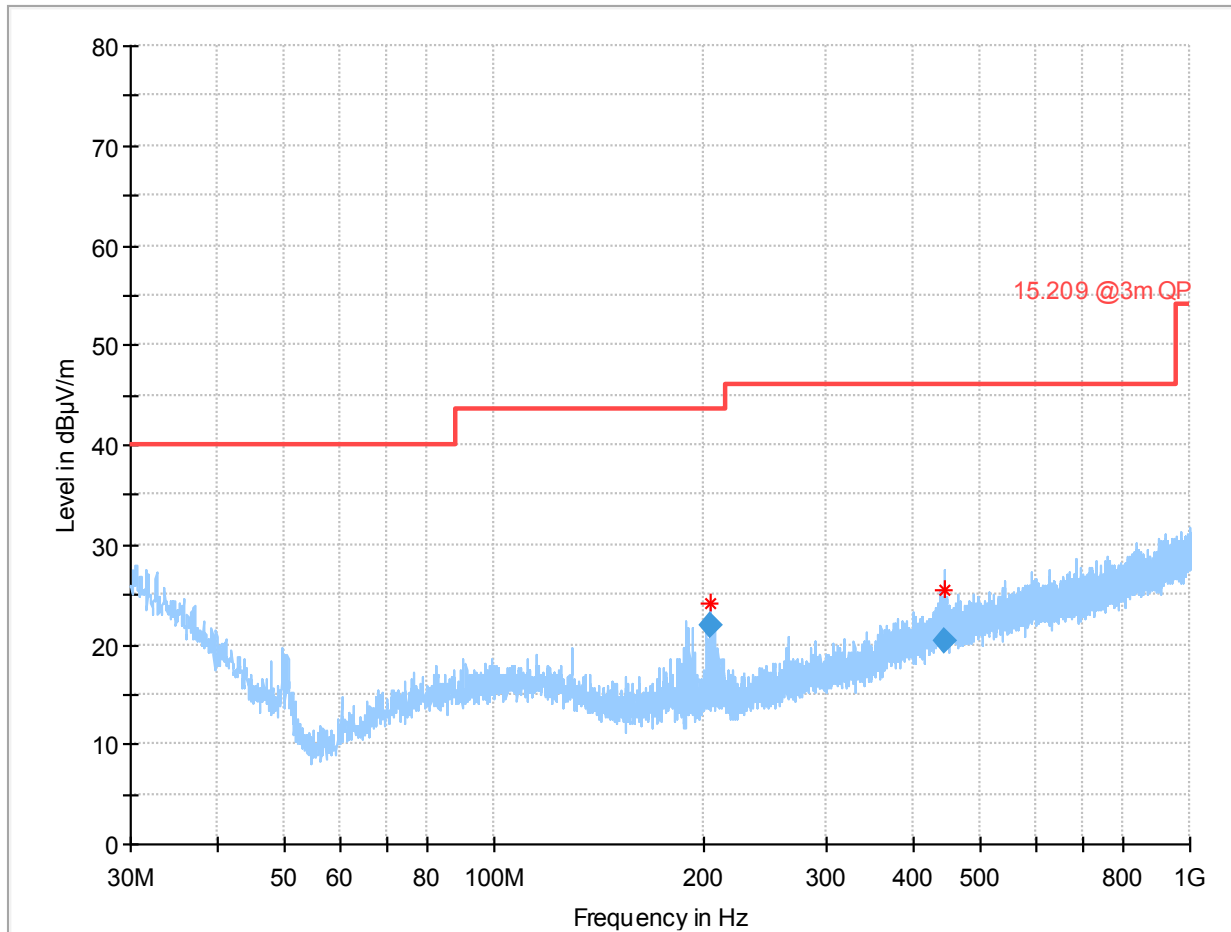

Frequency (MHz)	QuasiPeak (dBµV/m)	Limit (dBµV/m)	Margin (dB)	Meas. Time (ms)	Bandwidth (kHz)	Height (cm)	Pol	Azimuth (deg)
204.162000	22.01	43.50	21.49	100.0	120.000	100.0	V	17.0
443.121500	20.38	46.00	25.62	100.0	120.000	100.0	V	225.0

Annex A of TR no.: 21086129-23009-1

Plot 28: Mode 1, RSE 1 GHz – 3 GHz, low channel, horizontal / vertical polarisation

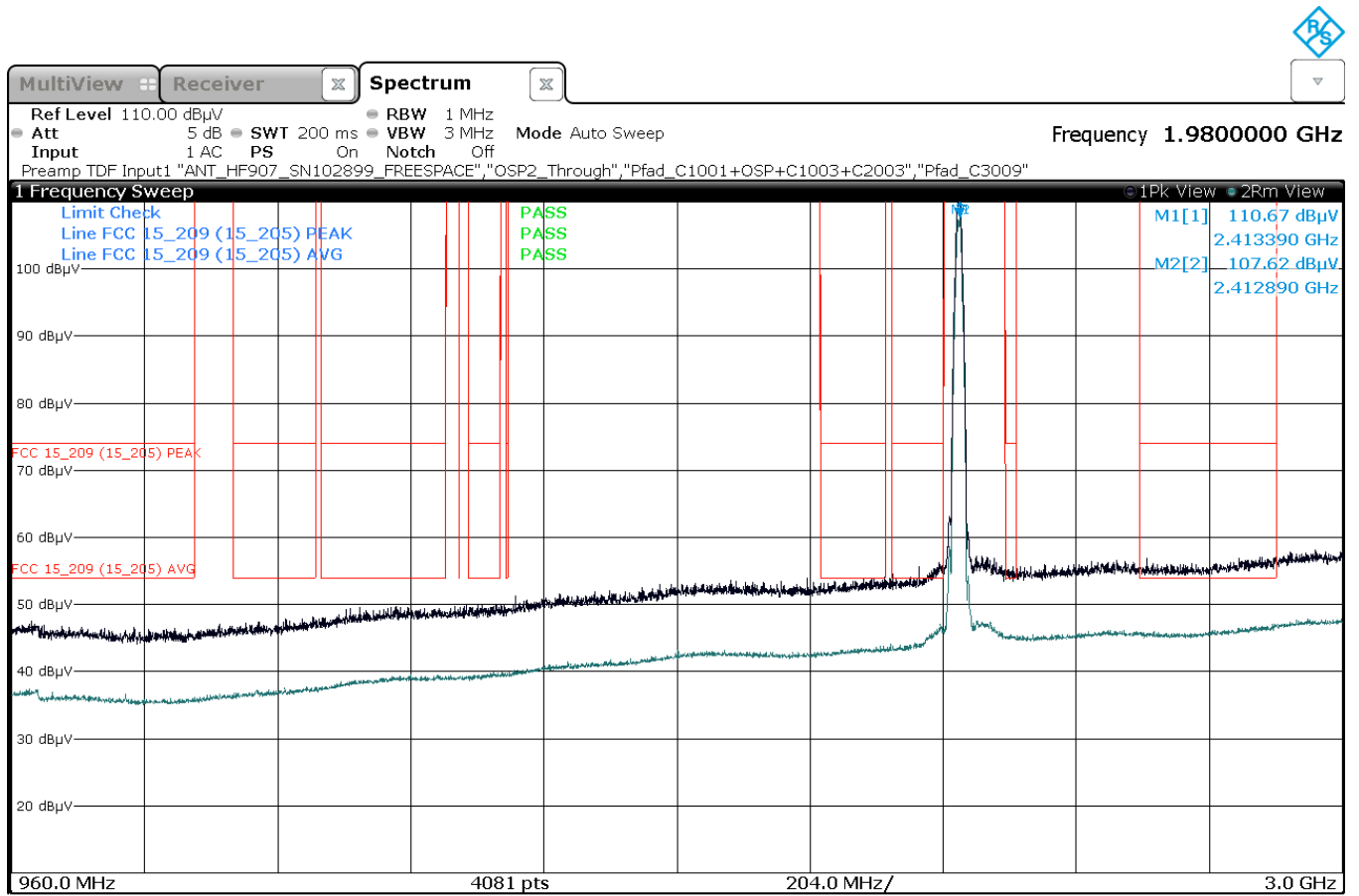

18:35:43 24.10.2021

Plot 29: Mode 1, RSE 1 GHz – 3 GHz, high channel, horizontal / vertical polarisation

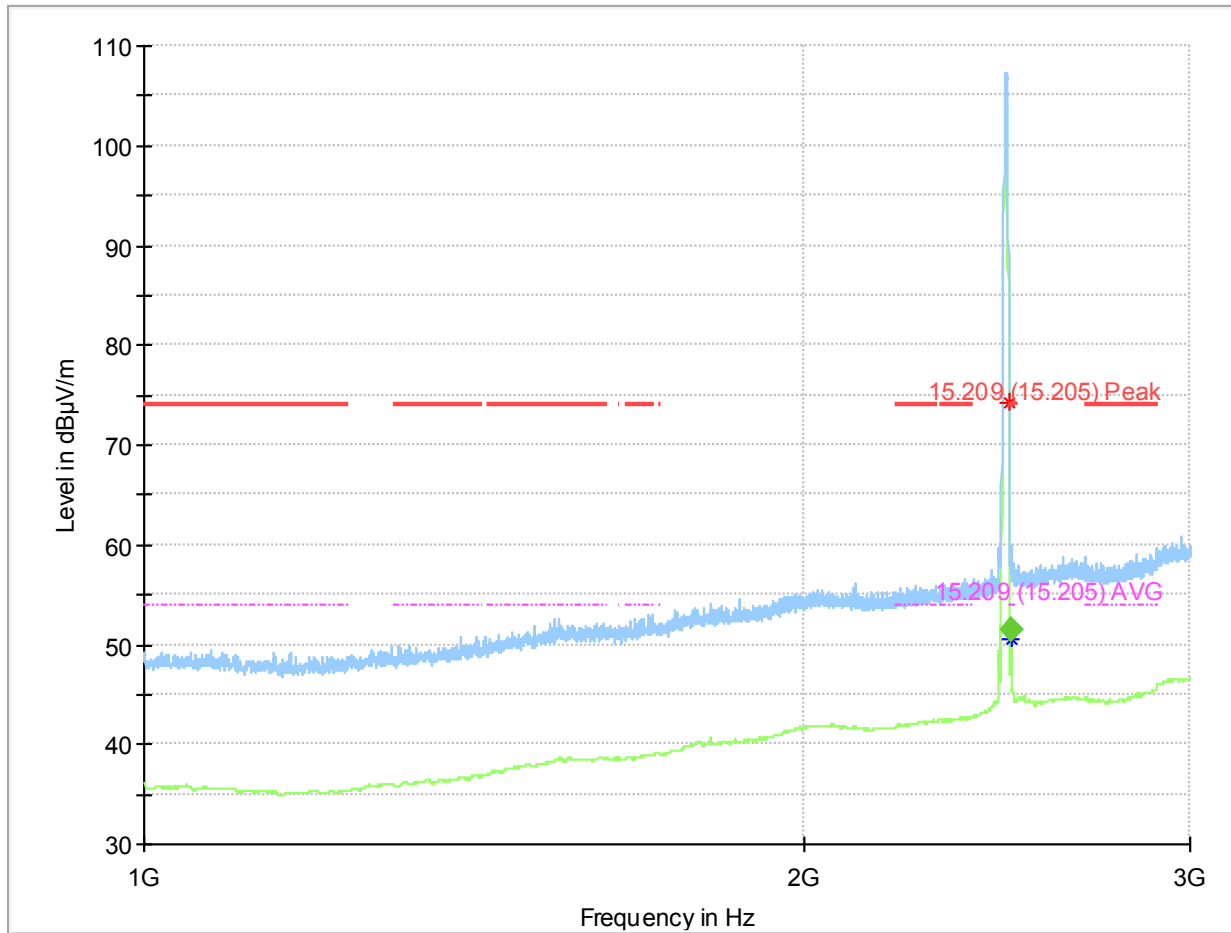

Final_Result

Frequency (MHz)	MaxPeak (dBµV/m)	Average (dBµV/m)	Limit (dBµV/m)	Margin (dB)	Meas. Time (ms)	Bandwidth (kHz)	Height (cm)	Pol
2485.750000	---	51.41	54.00	2.59	100.0	1000.000	150.0	V

(continuation of the "Final_Result" table from column 14 ...)

Frequency (MHz)	Azimuth (deg)	Elevation (deg)	Corr. (dB/m)	Comment
2485.750000	318.0	90.0	33.6	21:17:45 - 24.10.2021

Annex A of TR no.: 21086129-23009-1

Plot 30: Mode 1, RSE 3 GHz – 9 GHz, low channel, horizontal / vertical polarisation

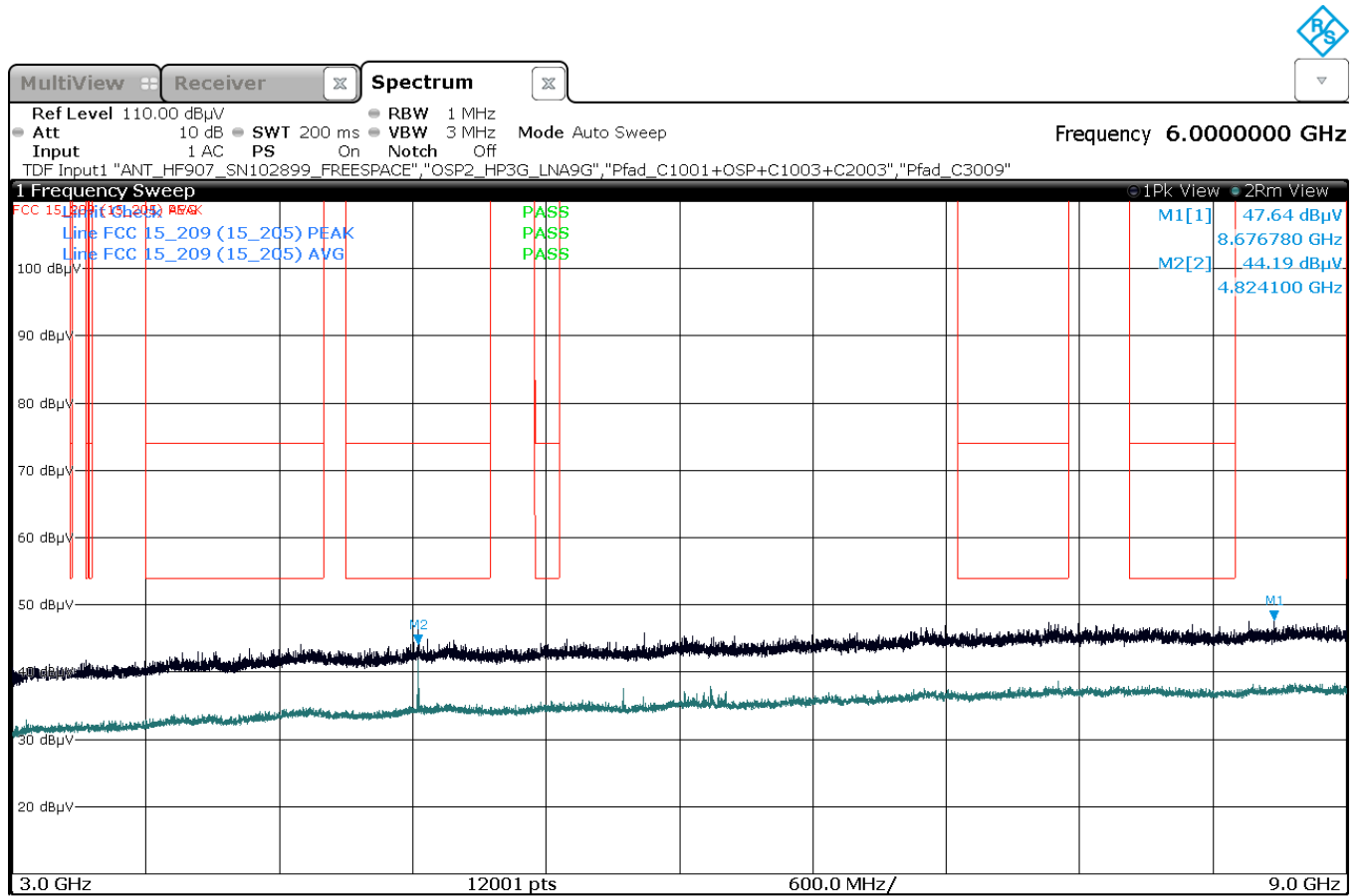

16:59:59 24.10.2021

Annex A of TR no.: 21086129-23009-1

Plot 31: Mode 1, RSE 3 GHz – 9 GHz, high channel, horizontal / vertical polarisation

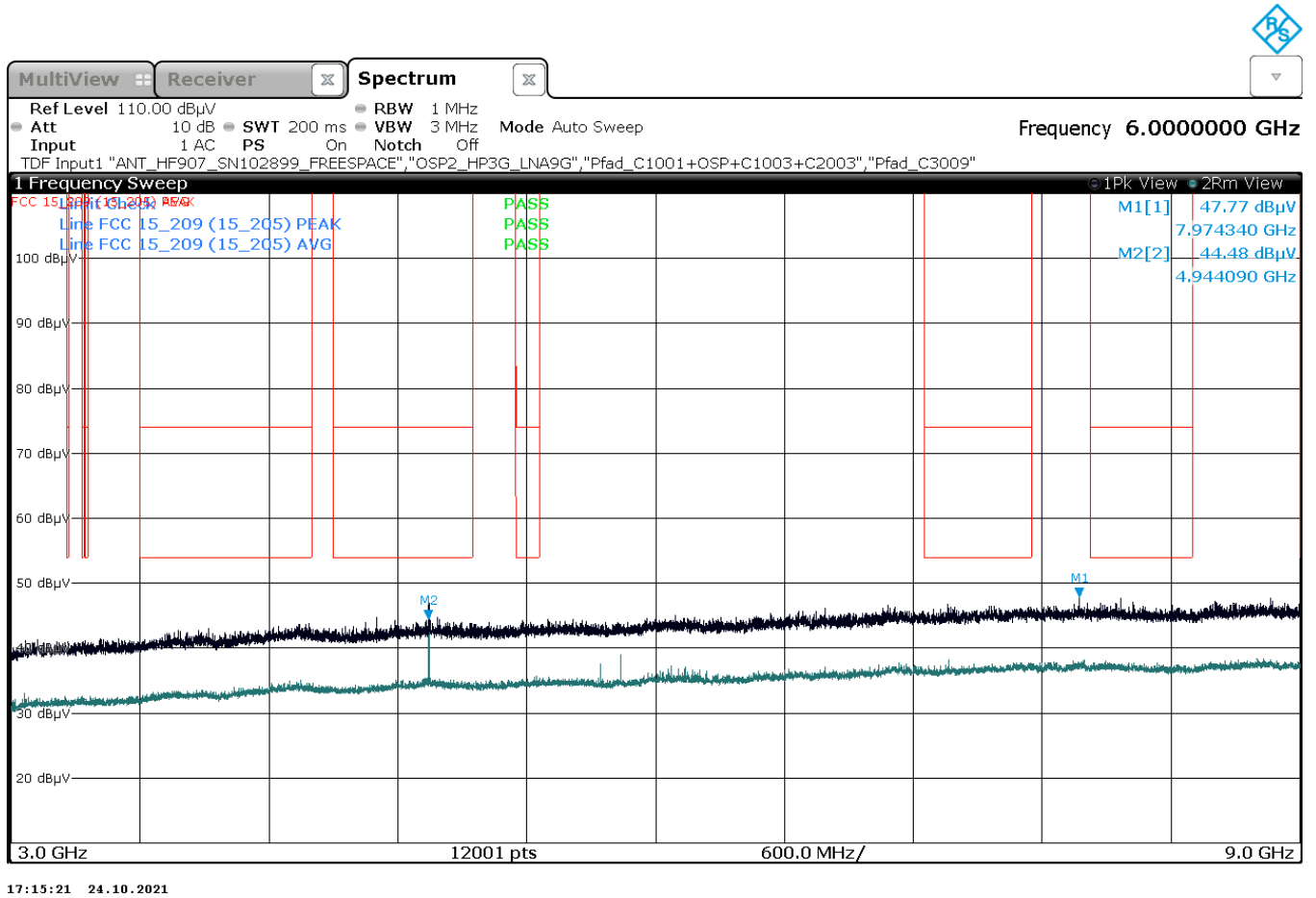

2.3 Variant ID #39

DUT Information

DUT Name: prePV 39
 Manufacturer: Mitsubishi Electric Corporation
 Serial Number: 65332 (conducted)
 65334 (radiated)

2.3.1 RF Output Power (Conducted Peak Power)

Test according to FCC title 47 part 15 §15.247(b), KDB 558074 D01 DTS Meas Guidance v05r02 and ANSI C63.10-2013 11.9.2.3.2

Measurement uncertainty calculated in accordance with ETSI TR 100 028-1.
 Expanded Combined Uncertainty of absolute Level Measurement (K=2) < 1 dB

DUT Information

DUT Name: prePV 39
 Manufacturer: Mitsubishi Electric Corporation
 Serial Number: 65332 (conducted)

Plot 32: Mode 1, AVGPM-G Gated Average Power Measurement, low channel

Result

DUT Frequency (MHz)	Gated RMS (dBm)	Limit Max (dBm)	Gated EIRP (dBm)	DutyCycle (%)	Result
2412.000000	13.0	30.0	13.0	98.859	PASS

Gated Trace

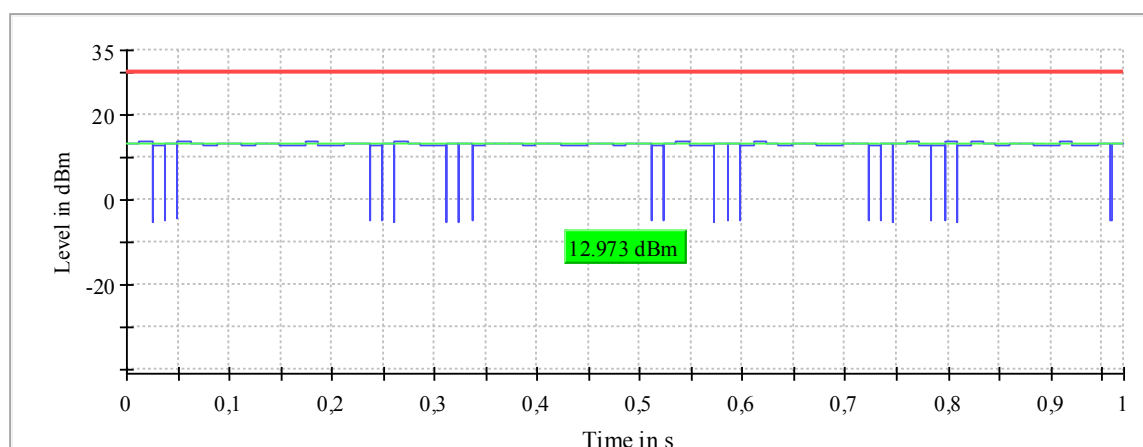

— Gated Trace — Overall — Limit

Plot 33: Mode 1, AVGP-G Gated Average Power Measurement, mid channel

Result

DUT Frequency (MHz)	Gated RMS (dBm)	Limit Max (dBm)	Gated EIRP (dBm)	DutyCycle (%)	Result
2442.000000	12.7	30.0	12.7	99.050	PASS

Gated Trace

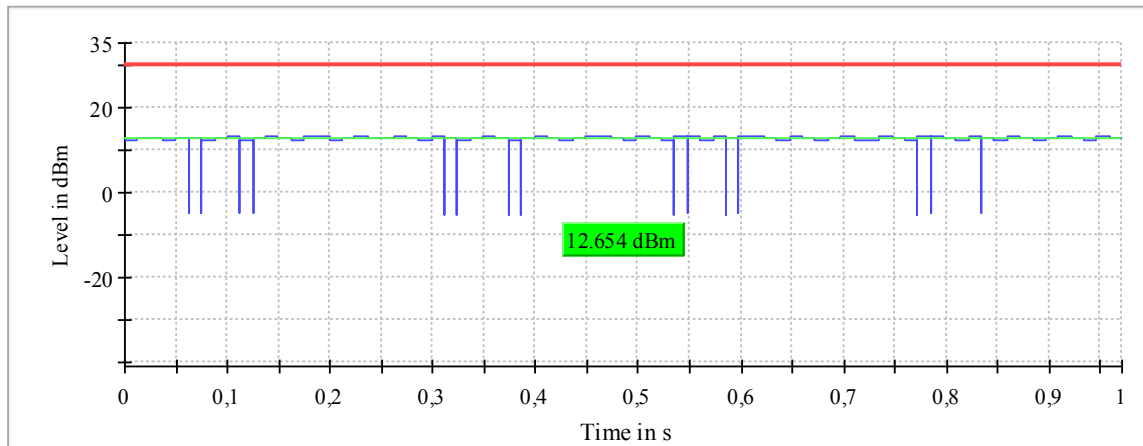

— Gated Trace — Overall — Limit

Plot 34: Mode 1, AVGP-G Gated Average Power Measurement, high channel

Result

DUT Frequency (MHz)	Gated RMS (dBm)	Limit Max (dBm)	Gated EIRP (dBm)	DutyCycle (%)	Result
2472.000000	12.5	30.0	12.5	99.053	PASS

Gated Trace

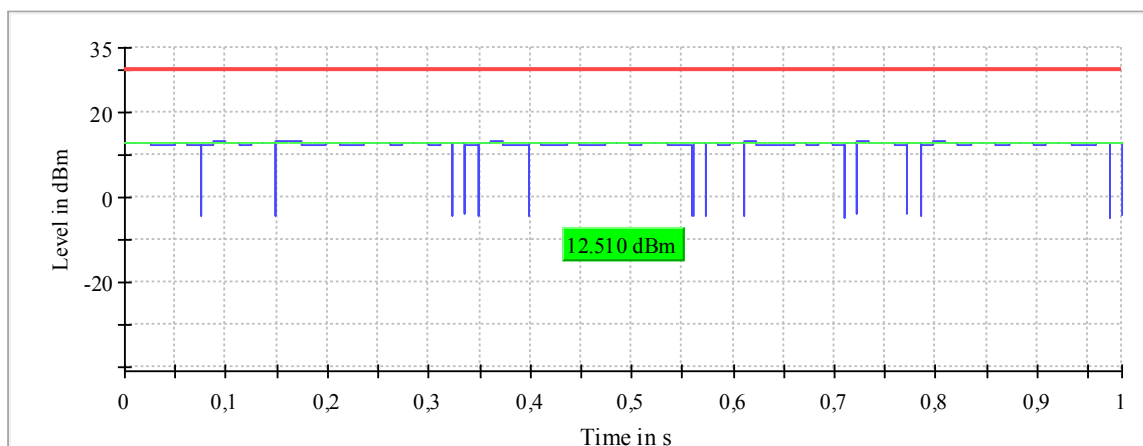

— Gated Trace — Overall — Limit

Annex A of TR no.: 21086129-23009-1

Plot 35: Mode 2, AVGPM-G Gated Average Power Measurement, low channel

Result

DUT Frequency (MHz)	Gated RMS (dBm)	Limit Max (dBm)	Gated EIRP (dBm)	DutyCycle (%)	Result
2412.000000	10.3	30.0	10.3	94.845	PASS

Gated Trace

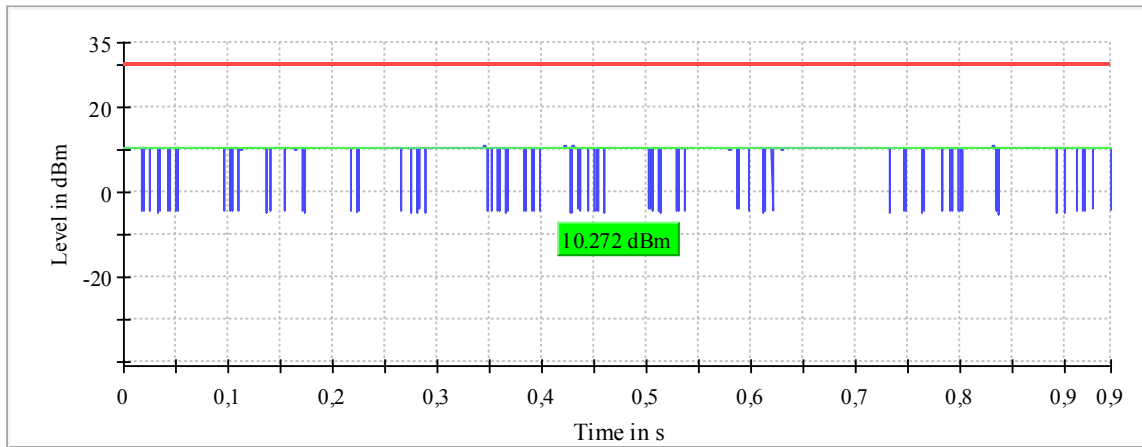

— Gated Trace — Overall — Limit

Plot 36: Mode 2, AVGPM-G Gated Average Power Measurement, mid channel

Result

DUT Frequency (MHz)	Gated RMS (dBm)	Limit Max (dBm)	Gated EIRP (dBm)	DutyCycle (%)	Result
2442.000000	10.0	30.0	10.0	94.156	PASS

Gated Trace

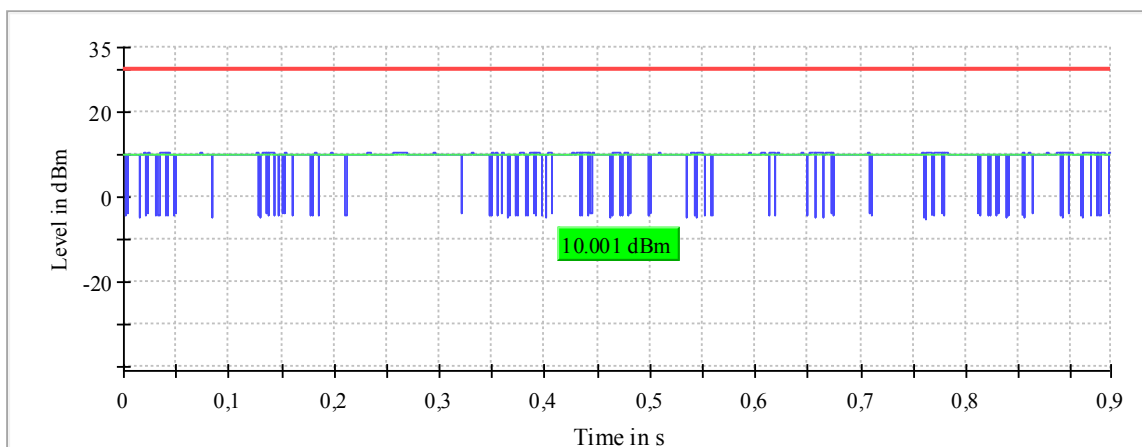

— Gated Trace — Overall — Limit

Plot 37: Mode 2, AVGPM-G Gated Average Power Measurement, high channel

Result

DUT Frequency (MHz)	Gated RMS (dBm)	Limit Max (dBm)	Gated EIRP (dBm)	DutyCycle (%)	Result
2472.000000	9.9	30.0	9.9	93.672	PASS

Gated Trace

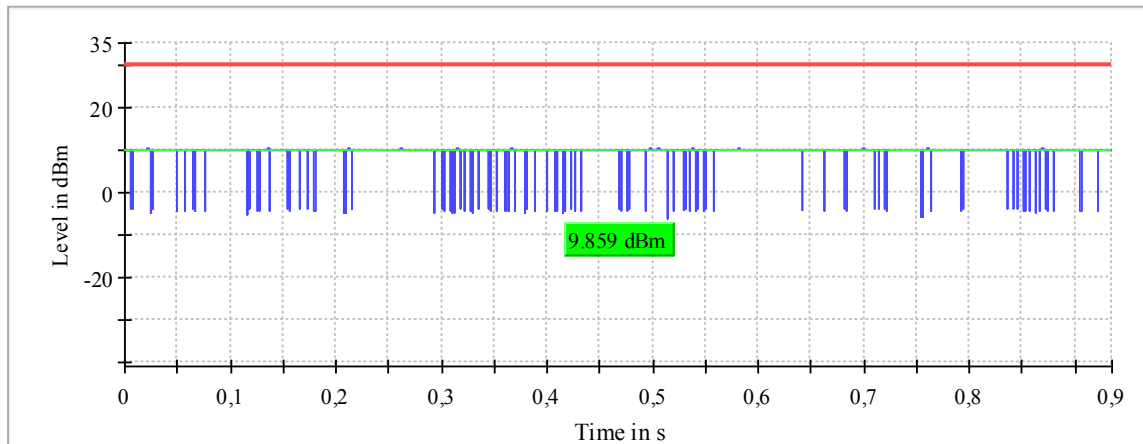

— Gated Trace — Overall — Limit

Plot 38: Mode 3, AVGPm-G Gated Average Power Measurement, low channel

Result

DUT Frequency (MHz)	Gated RMS (dBm)	Limit Max (dBm)	Gated EIRP (dBm)	DutyCycle (%)	Result
2412.000000	10.0	30.0	10.0	85.510	PASS

Gated Trace

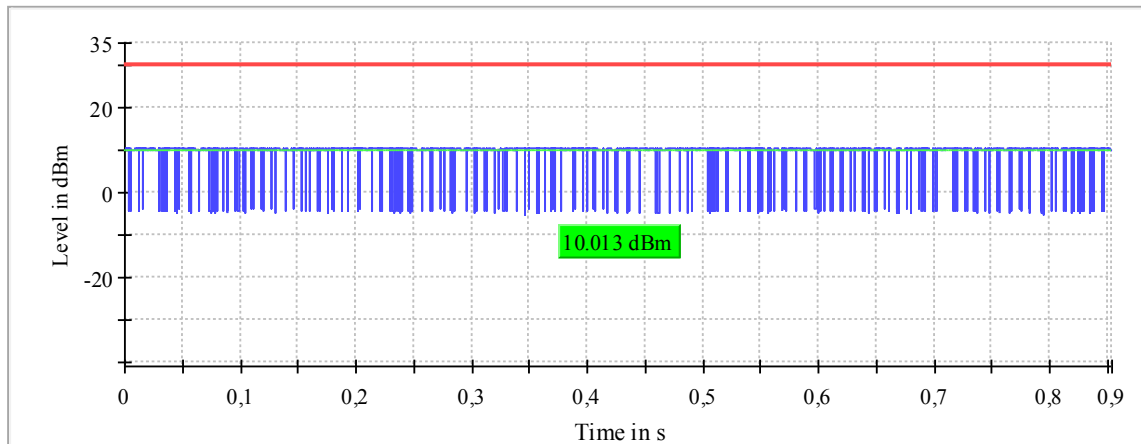

— Gated Trace — Overall — Limit

Plot 39: Mode 3, AVGPm-G Gated Average Power Measurement, mid channel

Result

DUT Frequency (MHz)	Gated RMS (dBm)	Limit Max (dBm)	Gated EIRP (dBm)	DutyCycle (%)	Result
2442.000000	9.8	30.0	9.8	88.259	PASS

Gated Trace

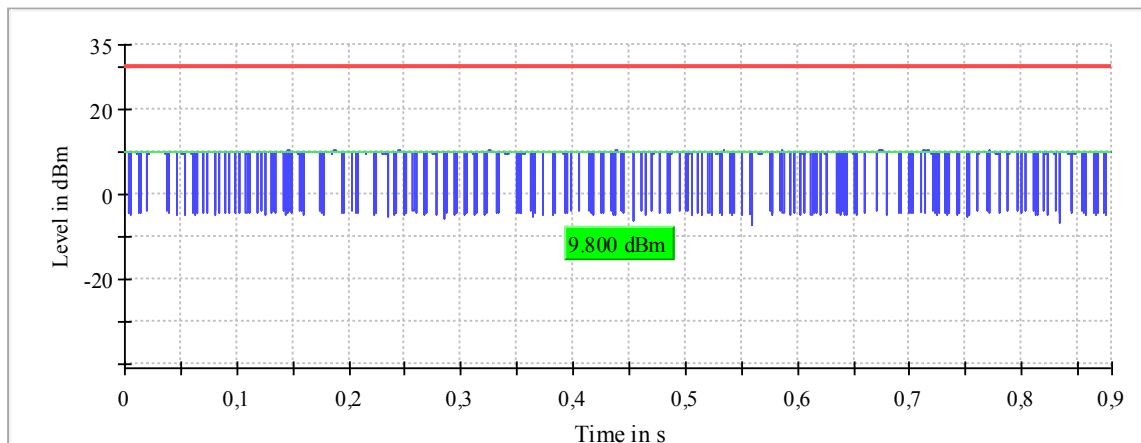

— Gated Trace — Overall — Limit

Plot 40: Mode 3, AVGPM-G Gated Average Power Measurement, high channel

Result

DUT Frequency (MHz)	Gated RMS (dBm)	Limit Max (dBm)	Gated EIRP (dBm)	DutyCycle (%)	Result
2472.000000	9.6	30.0	9.6	88.580	PASS

Gated Trace

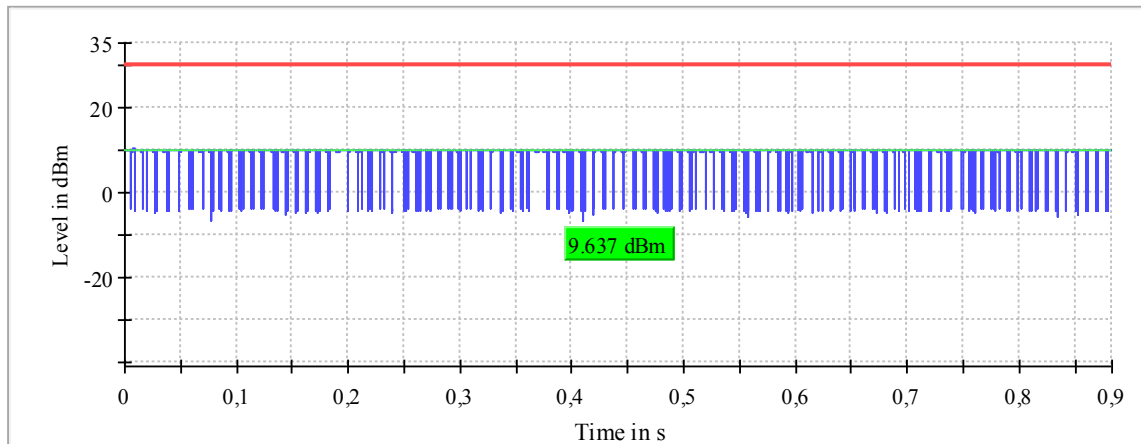

— Gated Trace — Overall — Limit

2.3.2 Radiated Peak Power (Peak EIRP)

Plot 41: Test Mode 1, DBPSK, 1 Mbit/s, Peak EIRP, low channel 1, 2412 MHz

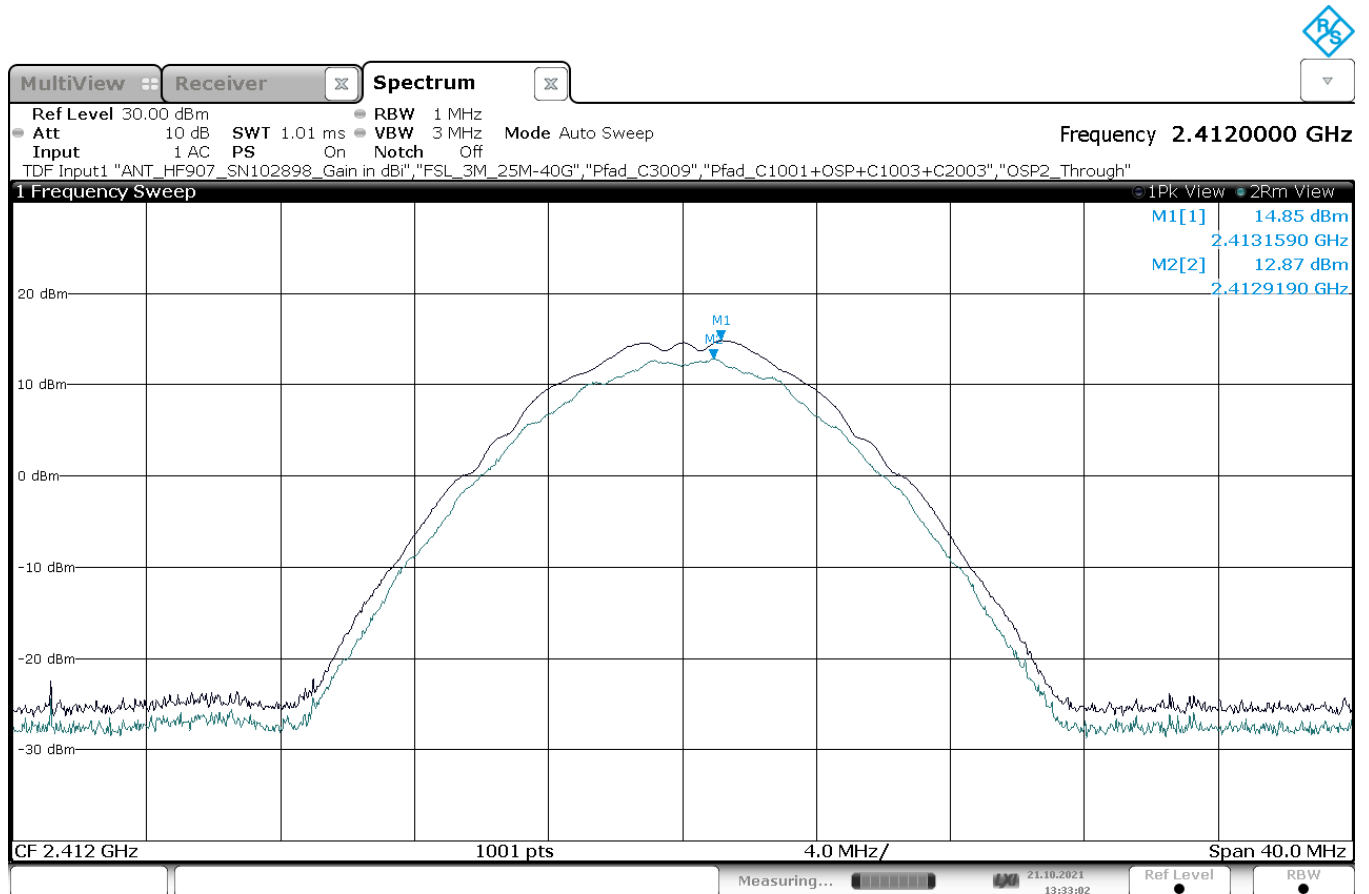

13:33:02 21.10.2021

Plot 42: Test Mode 1, DBPSK, 1 Mbit/s, Peak EIRP, high channel 13, 2472 MHz

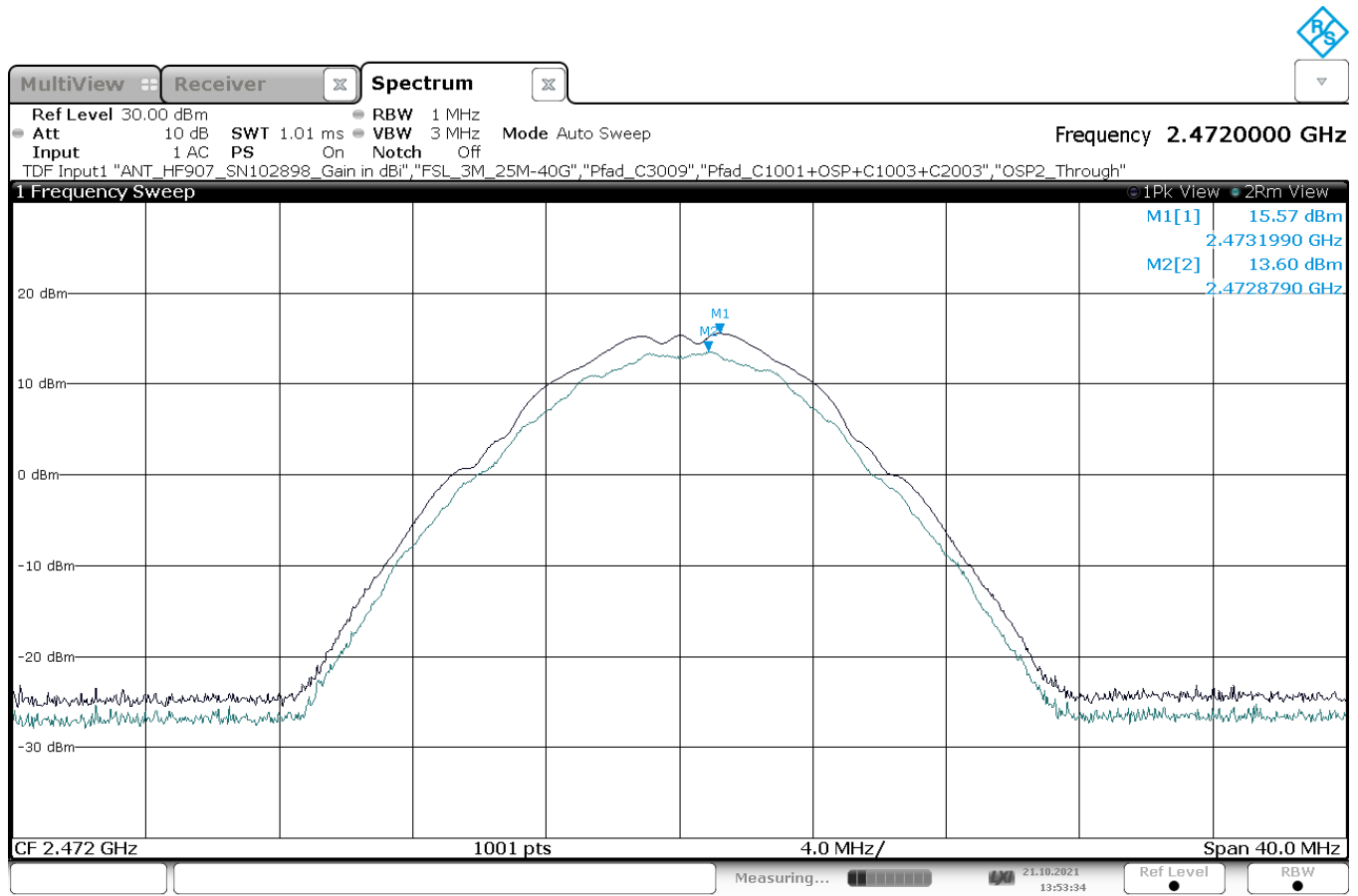

13:53:34 21.10.2021

2.3.3 Band Edge Compliance (BEC), radiated

Plot 43: Mode 1, BEC, low channel 1

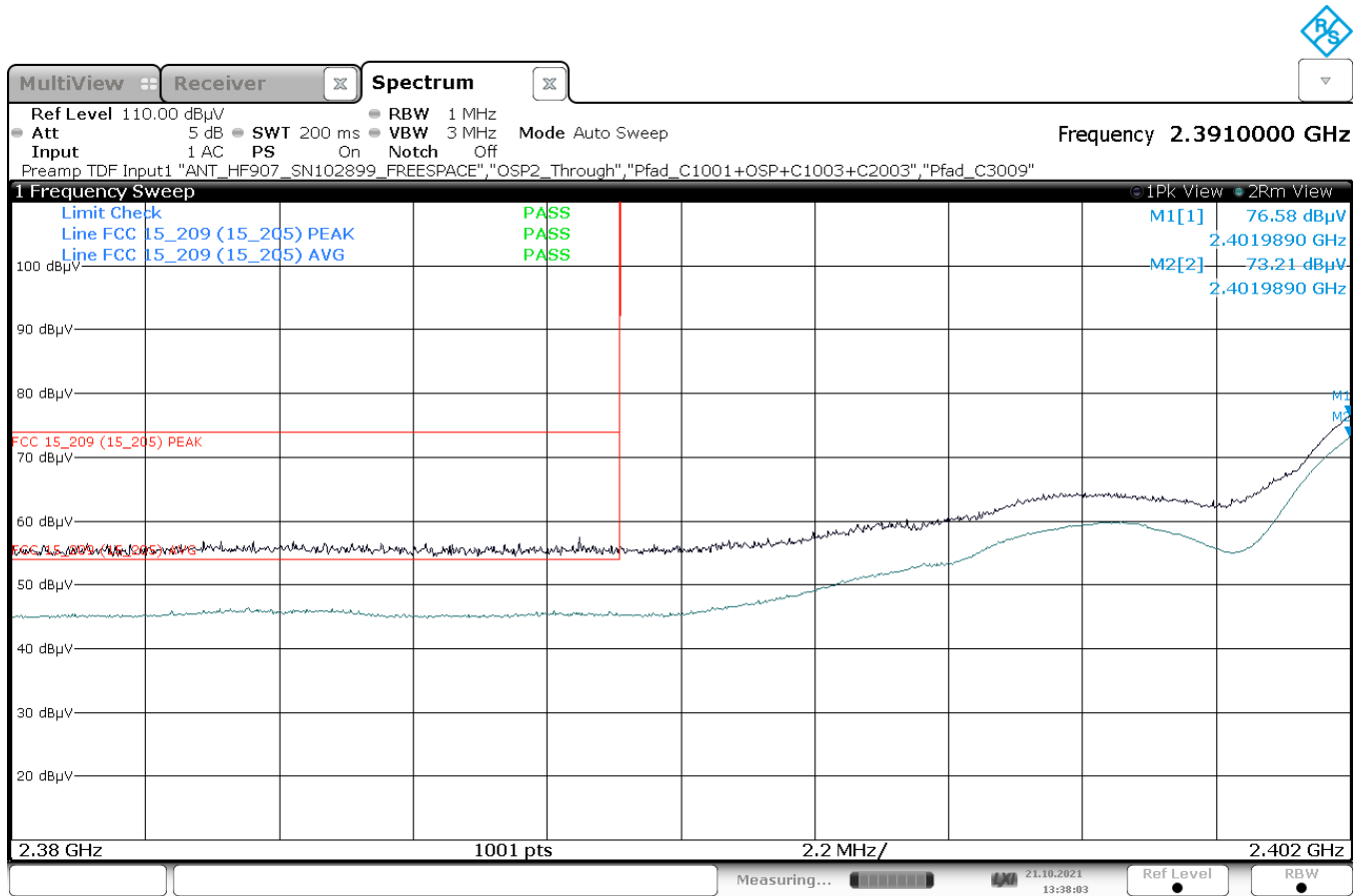

13:38:04 21.10.2021

Plot 44: Mode 1, BEC, high channel 13

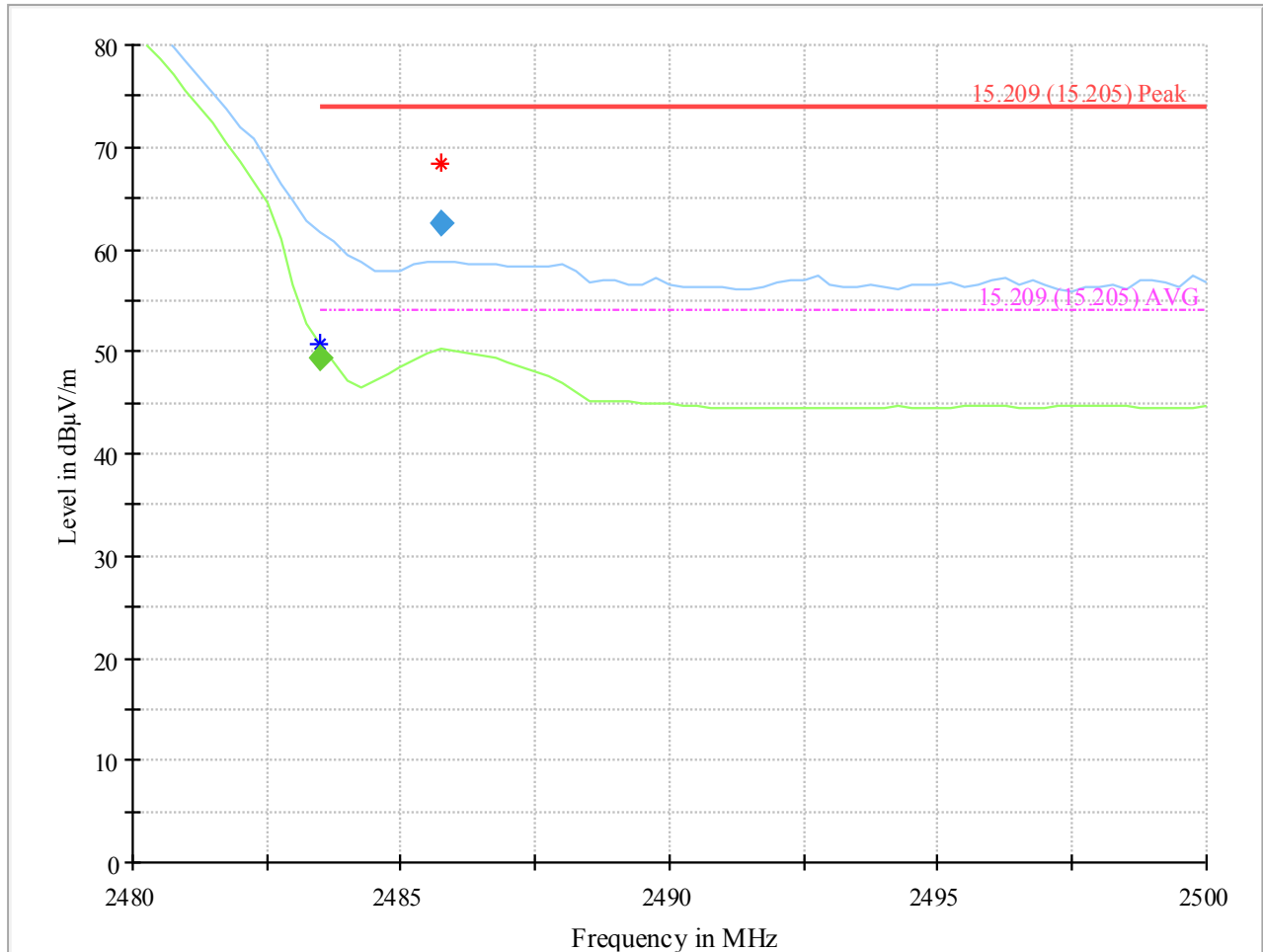

Final_Result

Frequency (MHz)	MaxPeak (dBµV/m)	Average (dBµV/m)	Limit (dBµV/m)	Margin (dB)	Meas. Time (ms)	Bandwidth (kHz)	Height (cm)	Pol
2483.500000	---	49.45	54.00	4.55	100.0	1000.000	150.0	V
2485.750000	62.47	---	74.00	11.53	100.0	1000.000	150.0	V

(continuation of the "Final_Result" table from column 14 ...)

Frequency (MHz)	Azimuth (deg)	Elevation (deg)	Corr. (dB/m)	Comment
2483.500000	3.0	90.0	33.6	16:02:28 - 21.10.2021
2485.750000	-16.0	90.0	33.6	16:01:53 - 21.10.2021

2.3.4 Radiated Spurious Emissions (RSE)

Plot 45: Mode 1, RSE 9 kHz – 30 MHz, low channel, loop antenna

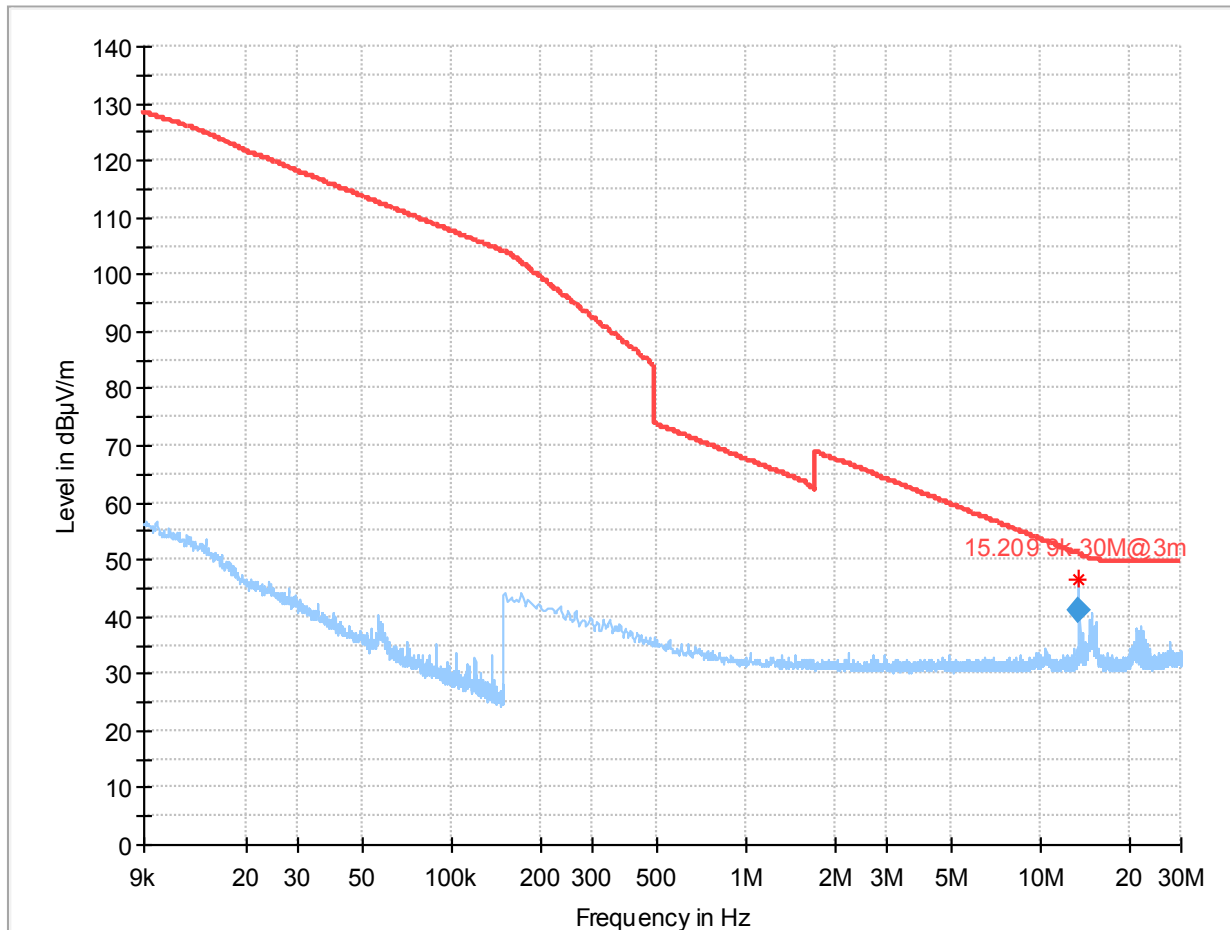

Final_Result

Frequency (MHz)	QuasiPeak (dBµV/m)	Limit (dBµV/m)	Margin (dB)	Meas. Time (ms)	Bandwidth (kHz)	Pol	Azimuth (deg)	Corr. (dB/m)
13.560000	41.24	50.94	9.70	100.0	9.000	V	-30.0	20.5

(continuation of the "Final_Result" table from column 15 ...)

Frequency (MHz)	Comment
13.560000	01:57:26 - 23.10.2021

Plot 46: Mode 1, RSE 9 kHz – 30 MHz, high channel, loop antenna

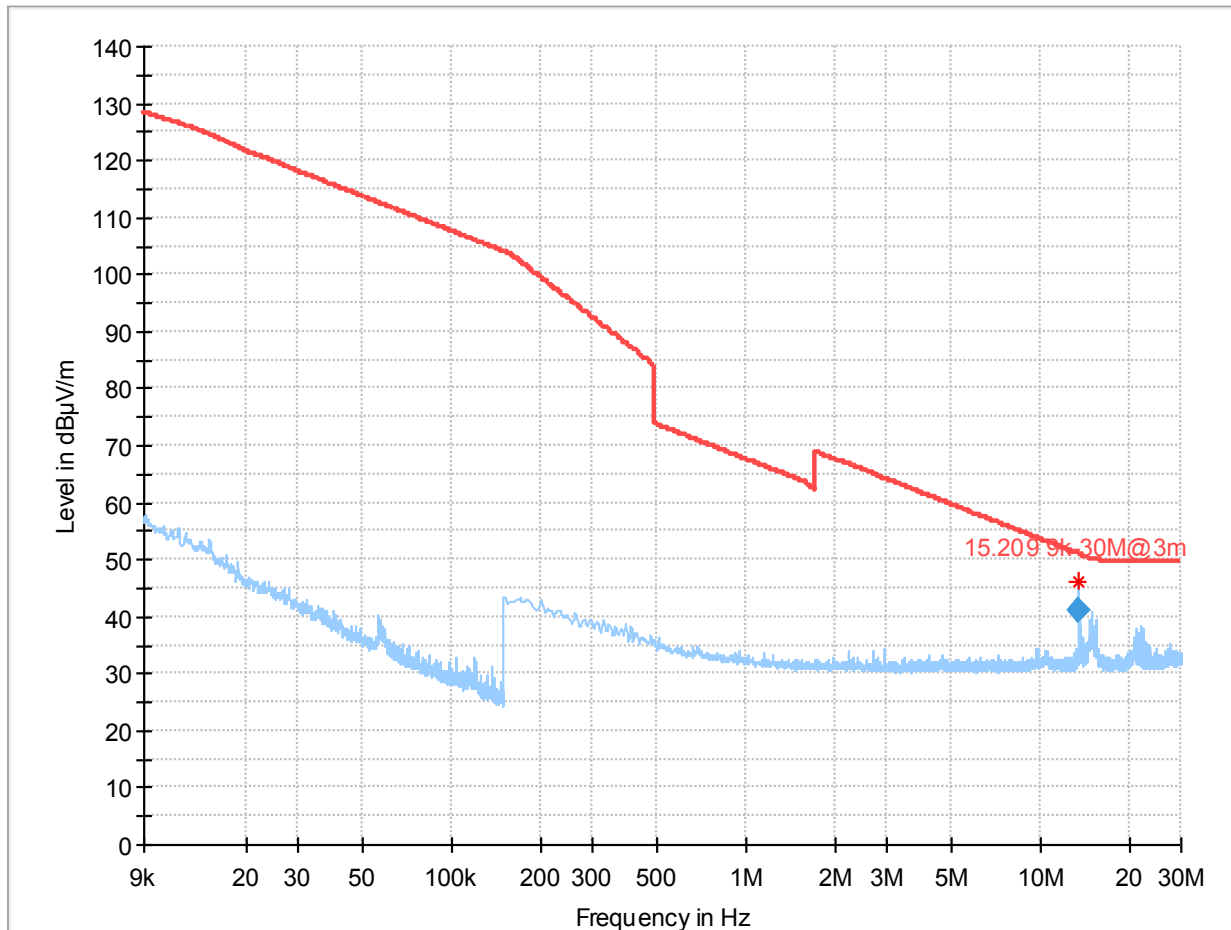

Frequency (MHz)	QuasiPeak (dBµV/m)	Limit (dBµV/m)	Margin (dB)	Meas. Time (ms)	Bandwidth (kHz)	Pol	Azimuth (deg)	Corr. (dB/m)
13.560000	41.04	50.94	9.90	100.0	9.000	H	300.0	20.5

Plot 47: Mode 1, RSE 30 MHz – 1 GHz, low channel, horizontal / vertical polarisation

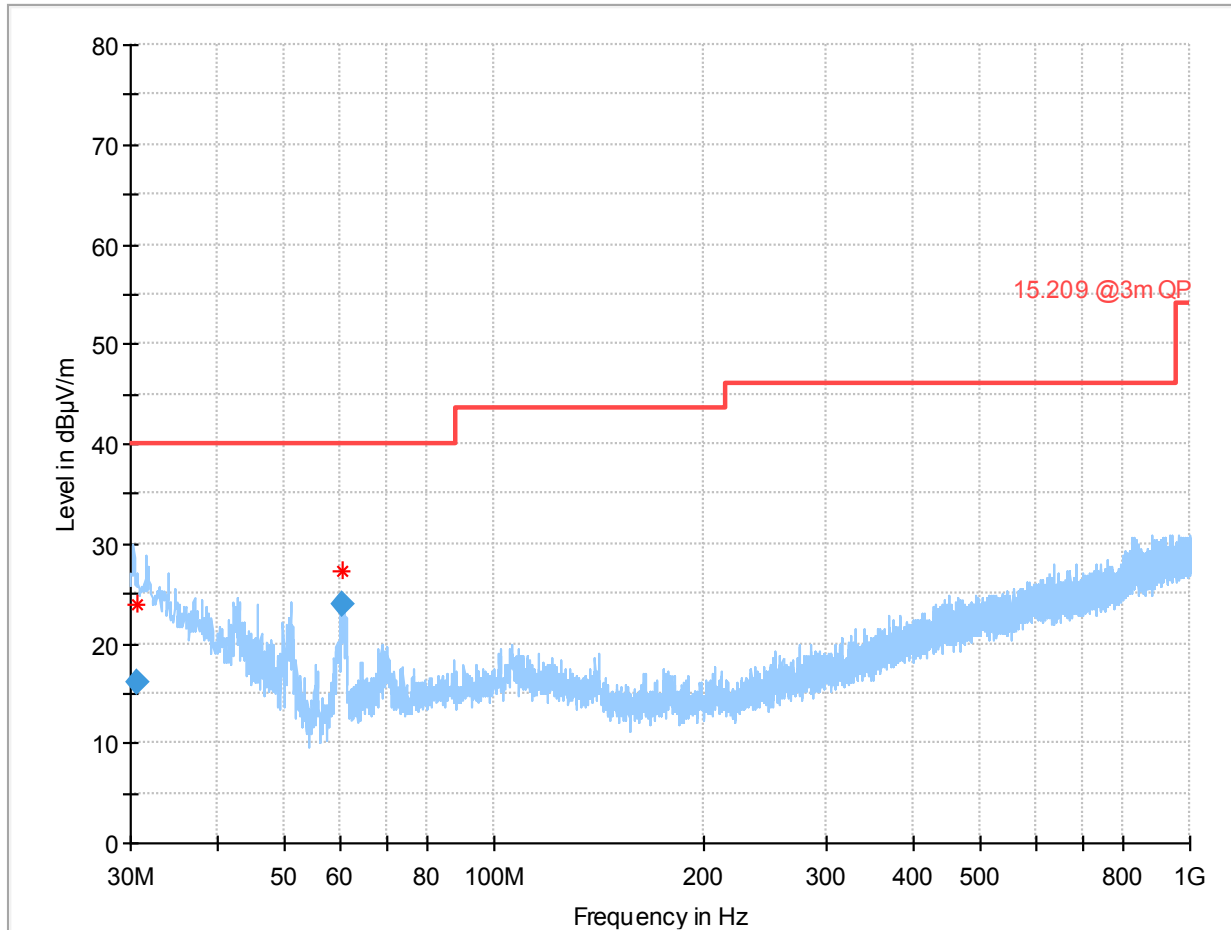

Frequency (MHz)	QuasiPeak (dBµV/m)	Limit (dBµV/m)	Margin (dB)	Meas. Time (ms)	Bandwidth (kHz)	Height (cm)	Pol	Azimuth (deg)
30.700000	16.18	40.00	23.82	100.0	120.000	104.0	V	245.0
60.684500	23.94	40.00	16.06	100.0	120.000	100.0	V	109.0

Annex A of TR no.: 21086129-23009-1

Plot 48: Mode 1, RSE 30 MHz – 1 GHz, high channel, horizontal / vertical polarisation

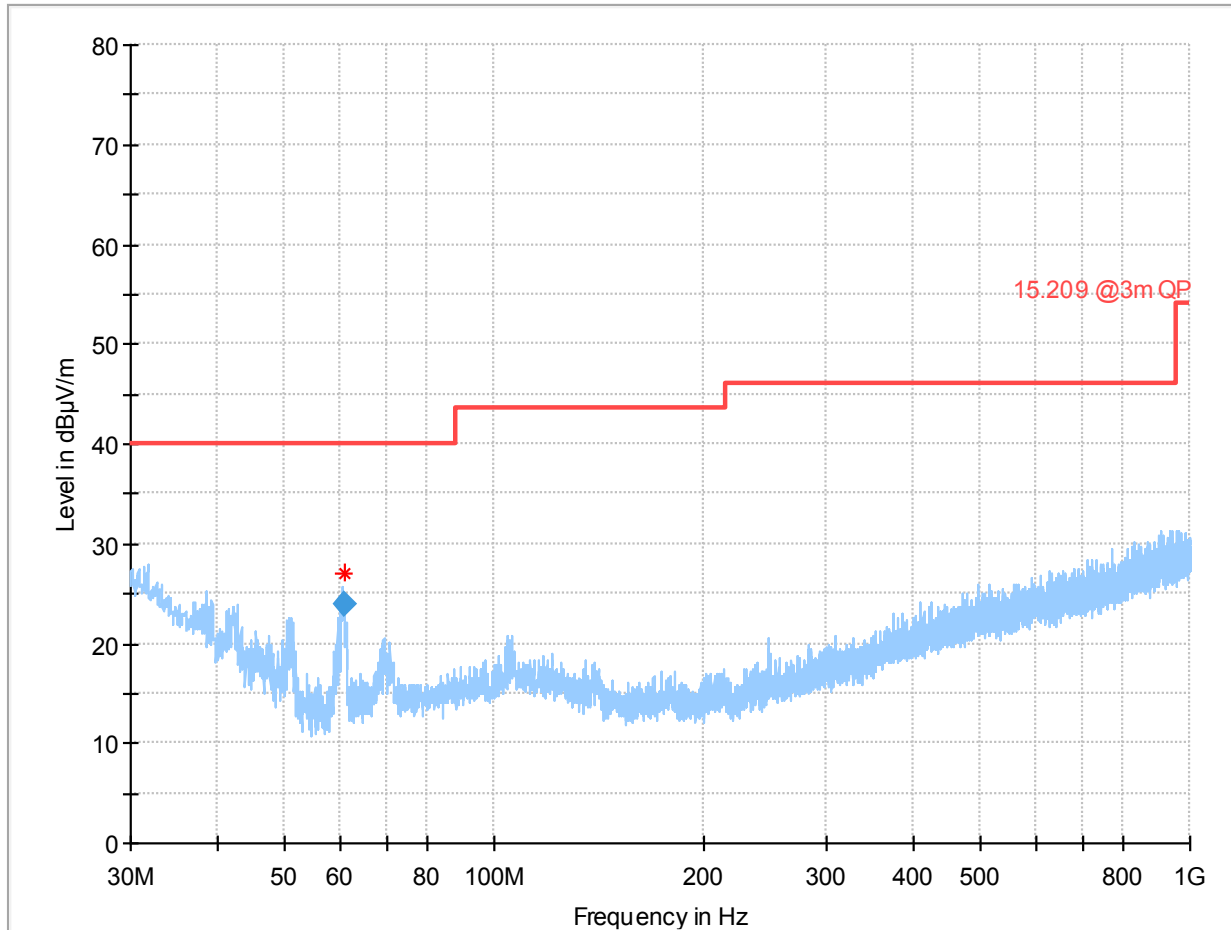

Annex A of TR no.: 21086129-23009-1

Plot 49: Mode 1, RSE 1 GHz – 3 GHz, low channel, horizontal / vertical polarisation

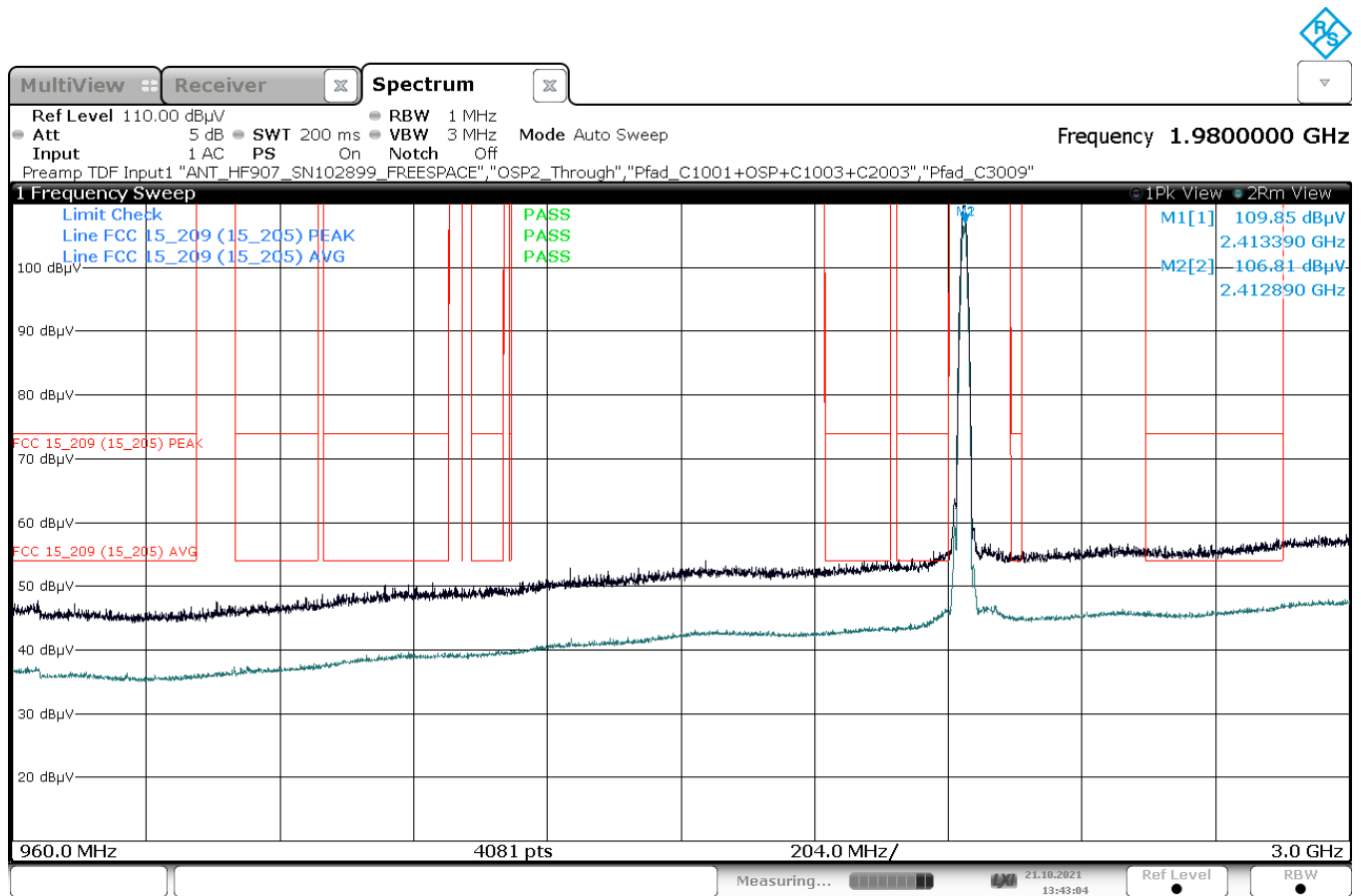

13:43:05 21.10.2021

Plot 50: Mode 1, RSE 1 GHz – 3 GHz, high channel, horizontal / vertical polarisation

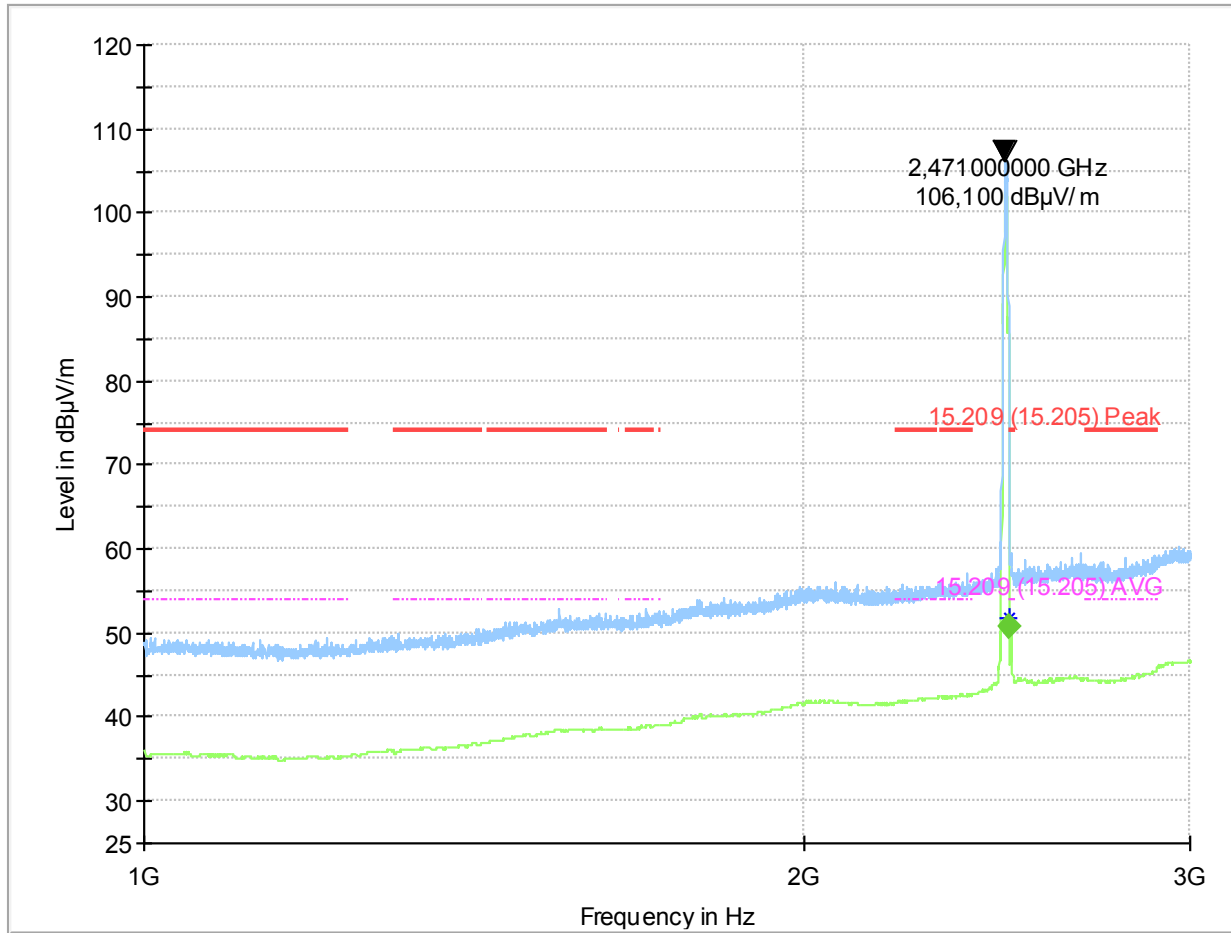

Plot 51: Mode 1, RSE 3 GHz – 9 GHz, low channel, horizontal / vertical polarisation

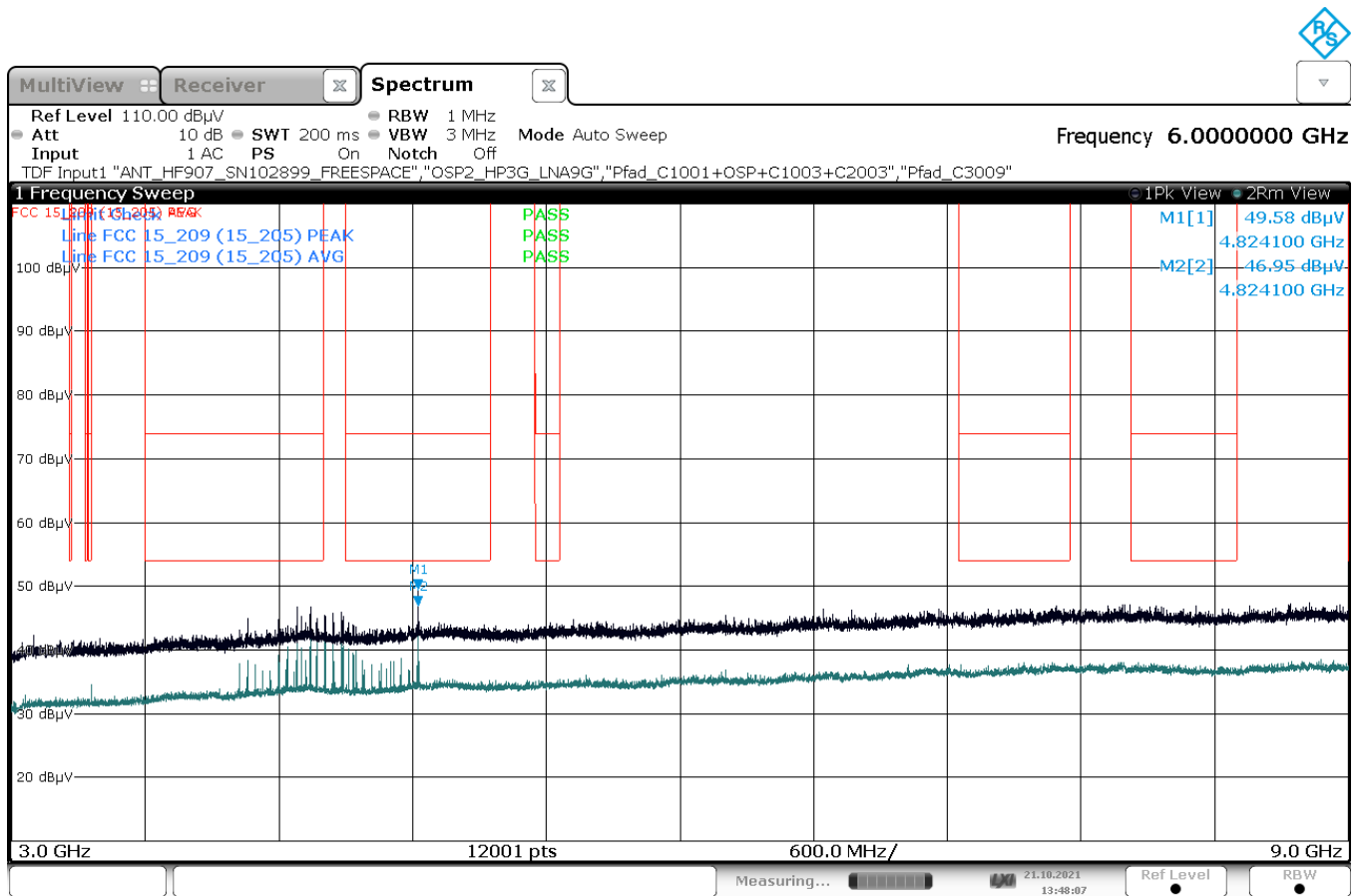

13:48:07 21.10.2021

Plot 52: Mode 1, RSE 3 GHz – 9 GHz, high channel, horizontal / vertical polarisation

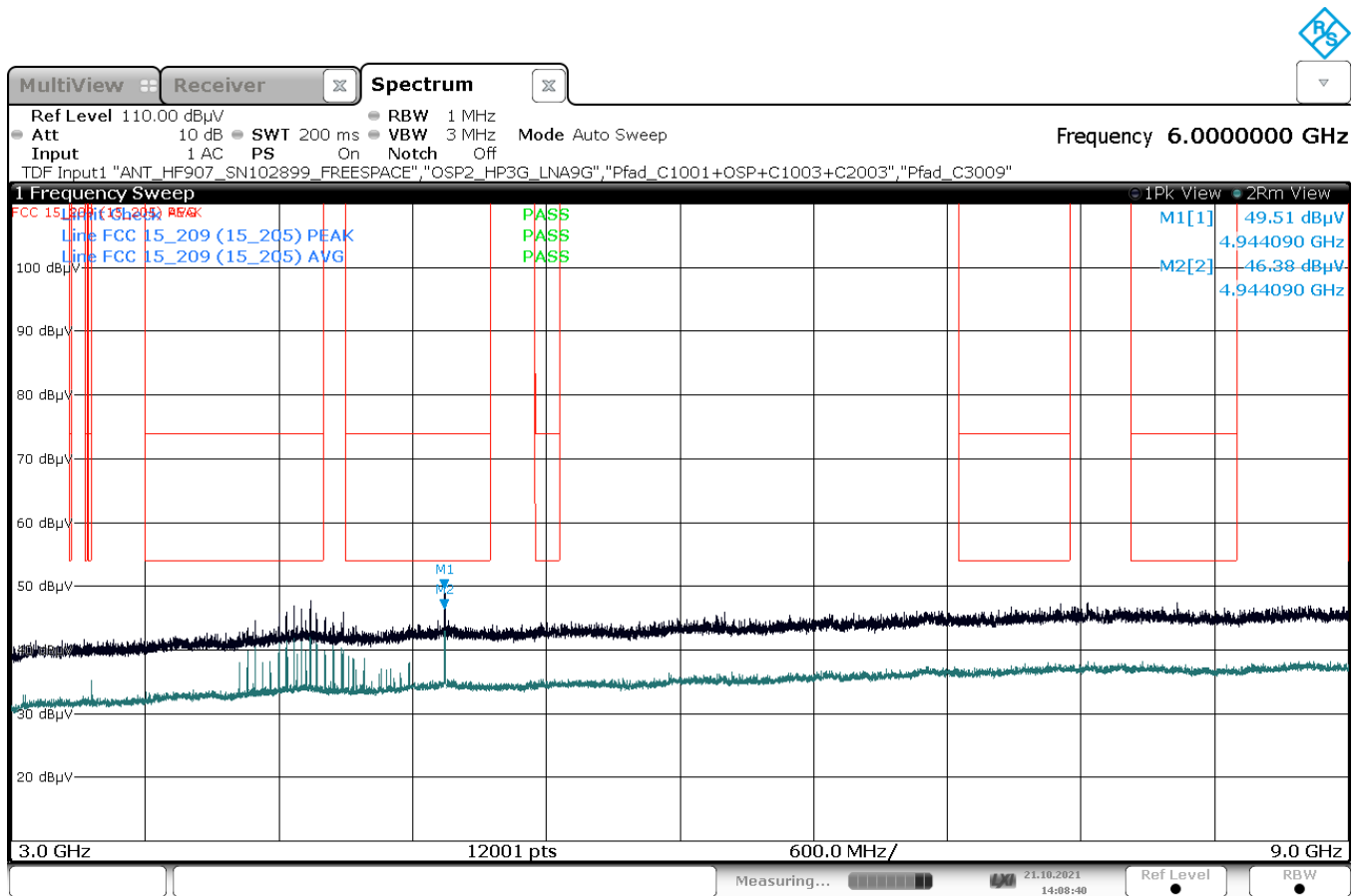

14:08:40 21.10.2021

2.4 Variant ID #43

DUT Information

DUT Name:	prePV 43
Manufacturer:	Mitsubishi Electric Corporation
Serial Number:	66704 (radiated)

2.4.1 RF Output Power (Conducted Peak Power)

See test results of R1LOW-R-SBM DV model (see IBL-Lab test report TR-21065799-20827)

2.4.2 Radiated Peak Power (Peak EIRP)

See test results of R1LOW-R-SBM DV model (see IBL-Lab test report TR-21065799-20827)

2.4.3 Band Edge Compliance (BEC), radiated

Plot 53: Mode 1, BEC, low channel 1

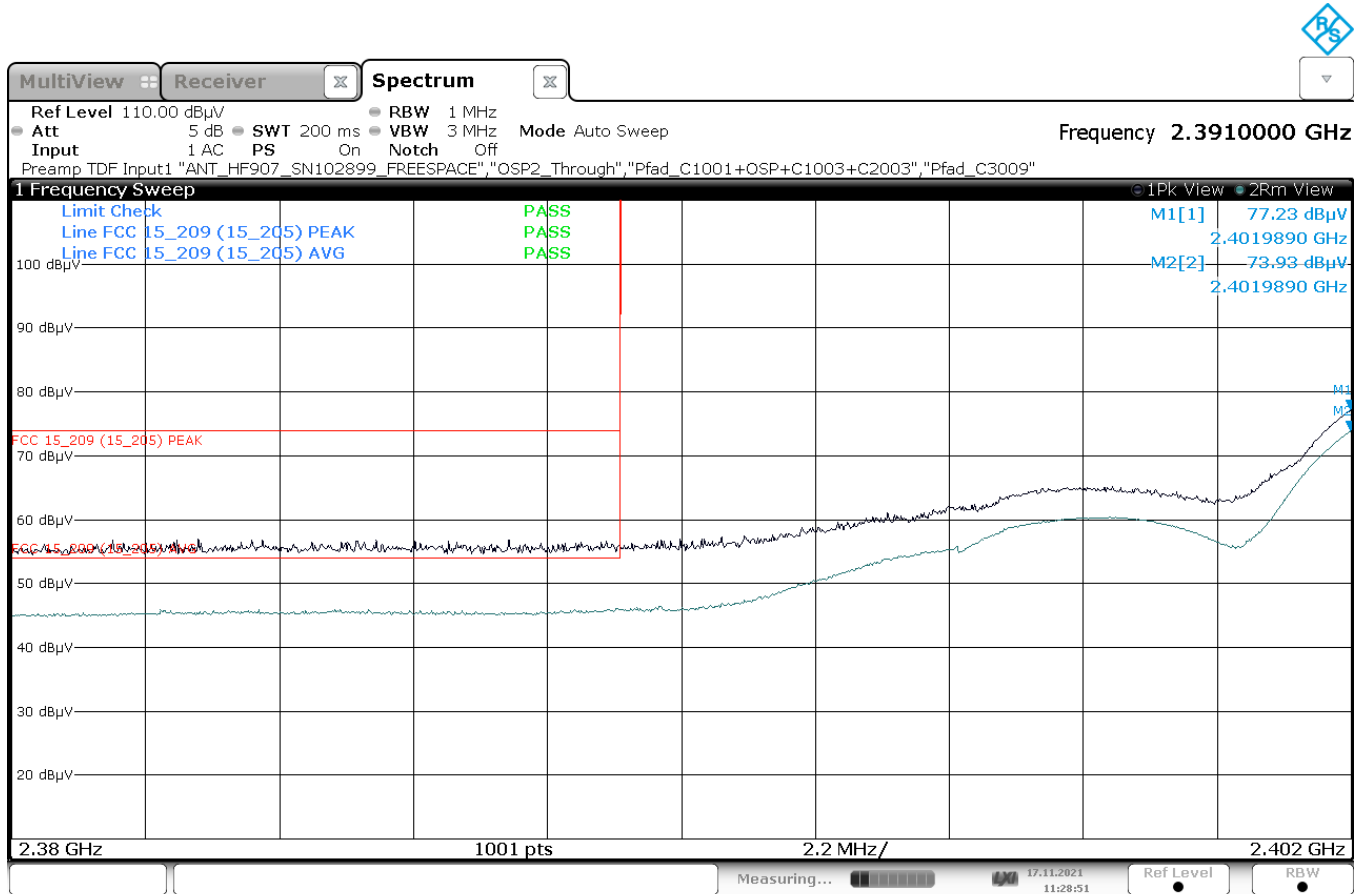

11:28:52 17.11.2021