

FCC PART 74.861
EMI MEASUREMENT AND TEST REPORT
For

Enping Oksn Electronics Technology Co.,Ltd.
No.180 South Suburb Industry area, Enping City, Guangdong, China

FCC ID: UGQPG4

April 10, 2012

This Report Concerns: Original Report	Equipment Type: UHF Wireless Microphone
Test Engineer:	Eric Li <i>Eric Li</i>
Report No.:	BST12030203Y-1ER-3
Receive EUT Date/Test Date:	April 2, 2012/ April 3-10, 2012
Reviewed By:	Christina <i>Christina</i>
Prepared By:	 Shenzhen BST Technology Co.,Ltd. 3F, Weames Technology Building, No. 10 Kefa Road, Science Park, Nanshan District, Shenzhen, Guangdong, China Tel: 0755-26747751 ~ 3 Fax: 0755-26747751 ~ 3 ext.826

Note: The test report is specially limited to the above company and this particular sample only. It may not be duplicated without prior written consent of Shenzhen BST Technology Co.,Ltd. This report must not be used by the client to claim product certification, approval, or endorsement by NVLAP, NIST or any agency of the US Government.

TABLE OF CONTENTS

1.	GENERAL INFORMATION	3
	1.1. Report information	3
	1.2. Measurement Uncertainty	3
2.	PRODUCT DESCRIPTION	4
	2.1. EUT Description	4
	2.2. Block Diagram of EUT Configuration.....	4
	2.3. Support Equipment List	4
	2.4. Test Conditions	4
3.	FCC ID LABEL.....	5
4.	TEST RESULTS SUMMARY	6
	Modifications	6
5.	TEST EQUIPMENT USED	7
6.	TEST RESULTS	8
	6.1. E.U.T. Operation Condition	8
	6.2. Test Procedure & Measurement Data	8
	6.2.1. Carrier Radiated Power & Radiated Spurious Emissions	8
	6.2.2. Occupied Bandwidth	11
	6.2.3. Frequency Stability	15
	6.2.4. Modulation Characteristics	17

1. GENERAL INFORMATION

1.1. Report information

1.1.1.This report is not a certificate of quality; it only applies to the sample of the specific product/equipment given at the time of its testing. The results are not used to indicate or imply that they are application to the similar items. In addition, such results must not be used to indicate or imply that BST approves recommends or endorses the manufacture, supplier or use of such product/equipment, or that BST in any way guarantees the later performance of the product/equipment.

1.1.2.The sample/s mentioned in this report is/are supplied by Applicant, BST therefore assumes no responsibility for the accuracy of information on the brand name, model number, origin of manufacture or any information supplied.

Additional copies of the report are available to the Applicant at an additional fee. No third part can obtain a copy of this report through BST, unless the applicant has authorized BST in writing to do so.

Test Facility -

The test site used to collect the radiated data is located on the address of

SinTek Laboratory Co.,Ltd.

(FCC Registered Test Site Number: 963441) on

No.7, Xinshidai Industrial, Guantian Village, Shiyan Town, Baoan District, Shenzhen, Guangdong 518108, China

The Test Site is constructed and calibrated to meet the FCC requirements.

1.2. Measurement Uncertainty

Available upon request.

2. PRODUCT DESCRIPTION

2.1. EUT Description

Description : UHF Wireless Microphone
 Applicant : Enping Oksn Electronics Technology Co.,Ltd.
 No.180 South Suburb Industry area, Enping City, Guangdong,
 China
 Model Number : PG4, SN-P300, SLX4, SN-U80, SN-58, SN-U77, SN-217U,
 PGX4, SN-P200
 Trade Name : N/A

Additional Information

Frequency Range : 645.000-674.700MHz (step 300kHz)
 Power Supply : DC 3V (Powered by two 1.5VDC batteries)
 Transmit Power : 10dBm
 Transmitter Antenna : Built-in antenna and soldered on the PCB

2.2. Block Diagram of EUT Configuration

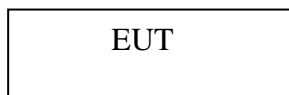

2.3. Support Equipment List

1.	--	-----
2.	--	-----
3.	--	-----

2.4. Test Conditions

Temperature: 20~25
 Relative Humidity: 55~63 %

3. FCC ID LABEL

FCC ID: UGQPG4

Label Location on EUT

EUT View/ FCC ID Label Location



4. TEST RESULTS SUMMARY

Test Items	Test Standards	Test Results
Carrier Radiated Power	74.861(e)(1)(ii) 614M-698M--250mW	Pass
Modulation Deviation	74.861 (e) (3) Within 75kHz	Pass
Frequency Stability	74.861 (e) (4) <0.005% 50 ppm	Pass
Operating Bandwidth	74.861 (e) (5) Within 200kHz	Pass
Unwanted Radiation	74.861 (e) (6) within the mask	Pass
Radiated Spurious Emission	74.861 (d) (3) < 43+10lgP(W) dB	Pass

Remark: "N/A" means "Not applicable."

Modifications

No modification was made.

5. TEST EQUIPMENT USED

Equipment/Facilities	Manufacturer	Model #	Serial no.	Date of Cal.	Cal. Interval
Cable	Resenberger	N/A	NO.1	Mar 10 , 2012	1 Year
Cable	SCHWARZBECK	N/A	NO.2	Mar 10 , 2012	1 Year
Cable	SCHWARZBECK	N/A	NO.3	Mar 10 , 2012	1 Year
LISN	Rohde & Schwarz	ESH3-Z5	100305	Mar 10 , 2012	1 Year
50 Coaxial Switch	ANRITSU CORP	MP59B	6200283933	Mar 10 , 2012	1 Year
EMI Test Receiver	Rohde & Schwarz	ESP13	100180	Oct.11,2011	1 Year
Spectrum Analyzer	Rohde & Schwarz	FSP40	100273	Sep.10,2011	1 Year
3m Semi-Anechoic Chamber	Albatross Projects	9m×6m×6m	N/A	Feb.20,2012	1 Year
Signal Generator	FLUKE	PM5418 + Y/C	LO747012	Feb.20,2012	1 Year
Signal Generator	FLUKE	PM5418TX	LO738007	Feb.20,2012	1 Year
Loop Antenna	SCHWARZBECK	FMZB1516	113	Jan.30,2012	1 Year
Trilog-Super Broadband Antenna	SCHWARZBECK	VULB9161	9161-4079	Sep.22,2011	1 Year
Broad-Band Horn Antenna	SCHWARZBECK	BBHA9120D	9120D-564	Sep.22,2011	1 Year
Ultra Broadband Antenna	Rohde & Schwarz	HL-562	100110	June.15,2011	1 Year
AMN	Rohde & Schwarz	ESH3-Z5	100196	Oct.11,2011	1 Year
AMN	Rohde & Schwarz	ESH3-Z5	100197	Oct.11,2011	1 Year
Pulse Limiter	Rohde & Schwarz	ESH3-Z2	N/A	N/A	N/A
Power Meter	Rohde & Schwarz	NRVD	100041	Feb.20,2012	1 Year
EMI Test Receiver	Rohde & Schwarz	ESCS30	100003	Feb.20,2012	1 Year
Coaxial Cable with N-connectors	SCHWARZBECK	AK9515H	95549	Sep.22,2011	1 Year
Radio Communication Test Set	Rohde & Schwarz	CMS 54	846621/024	Feb.20,2012	1 Year
Modulation Analyzer	Hewlett-Packard	8901B	2303A00362	Feb.20,2012	1 Year
Absorbing clamp	Rohde & Schwarz	MDS-21	N/A	Oct.11,2011	1 Year

6. TEST RESULTS

6.1. E.U.T. Operation Condition

Operating Environment:

Temperature: 20.0 ° C~25 ° C

Humidity: 56 ~68% RH

Atmospheric Pressure: 980~1012 mbar

EUT Operation: Test the EUT in transmitting mode.

6.2. Test Procedure & Measurement Data

6.2.1. Carrier Radiated Power & Radiated Spurious Emissions

Test Requirement: FCC CFR 47 Part 74.861 e) 1) & d) 3)

Test Method: EIA/TIA 603-C-2004 section 2.2,
FCC CFR 47 Part 2.1047 & 1053

Test Date: April 5, 2012

Measurement Distance: 3m (Semi-Anechoic Chamber)

Test Requirement:

- (d) For low power auxiliary stations operating in the bands other than those allocated for TV broadcasting, the following technical requirements are imposed.
- (3) The occupied bandwidth shall not be greater than that necessary for satisfactory transmission and, in any event, an emission appearing on any discrete frequency outside the authorized band shall be attenuated, at least, $43+10 \log_{10}$ (mean output power, in watts) dB below the mean output power of the transmitting unit.
- (e) For low power auxiliary stations operating in the bands allocated for TV broadcasting, the following technical requirements apply:
 - (1) The power of the measured unmodulated carrier power at the output of the transmitter power amplifier (antenna input power) may not exceed the following:
 - (i) 54–72, 76–88, and 174–216 MHz bands—50 mW
 - (ii) 470–608 and 614–698 MHz bands—250 mW

Test Procedure:

Carrier Radiated Power

The output from the antenna port of the test item was connected to spectrum analyzer through 40 dB of attenuation. The output of the test item was then measured.

Radiated Spurious Emissions

The procedure used was EIA/TIA 603-C-2004. The receive was scanned from 9kHz to 7.0GHz. When an emission was found, the table was rotated to produce the maximum signal strength. An initial pre-scan was performed for in peak detection mode using the receiver. The EUT was measured for both the Horizontal and Vertical polarities and performed a pre-test three orthogonal planes.

The field strength is calculated by adding the Antenna Factor, Cable Factor &Peramplifier. The basic equation with a sample calculation is as follows:

$$\text{Final Test Level} = \text{Receiver Reading} + \text{Antenna Factor} + \text{Cable Factor} - \text{Peramplifer Factor}$$

An initial pre-scan was performed in the 3m chamber using the spectrum analyser in peak detection mode. Quasi-peak measurements were conducted based on the peak sweep graph. The EUT was measured by Bilog antenna with 2 orthogonal polarities

Remove the EUT and replace it with substitution antenna. A signal generator was connected to the substitution antenna by a non-radiating cable. The absolute levels of the Carrier Radiated Power and spurious emissions were measured by the substitution.

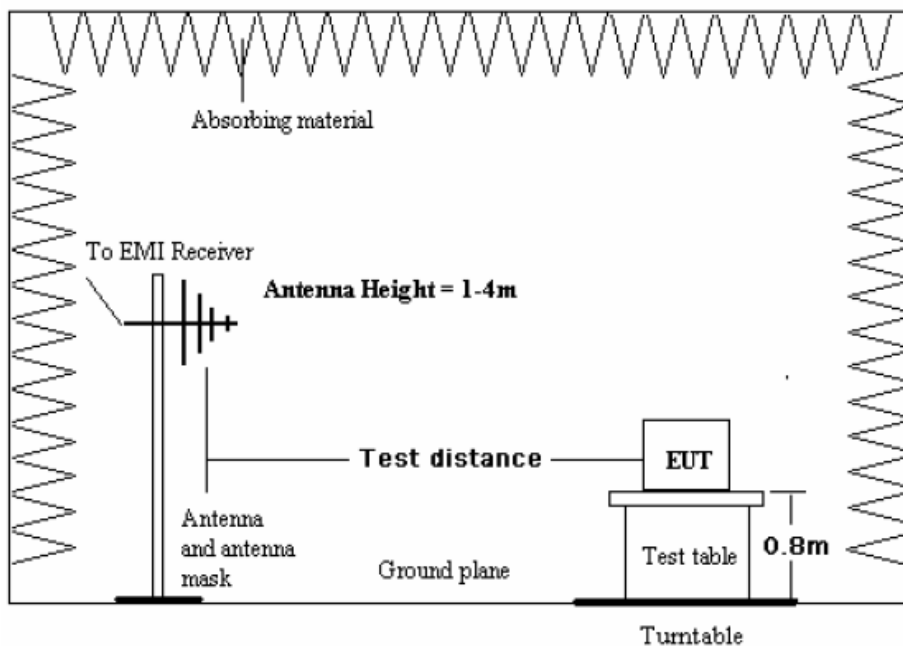

Test Result:

Carrier Radiated Power

Carrier Frequency (MHz)	Factual Level dBm (mW)	Limit in 74.861 e) 1)
645.000	9.90 dBm(i.e. 9.77mW)	24 dBm (i.e. 250 mW)
660.000	9.93 dBm(i.e. 9.84mW)	24 dBm (i.e. 250 mW)
674.700	9.91 dBm(i.e. 9.79mW)	24 dBm (i.e. 250 mW)

Radiated spurious emissions:

Spurious Emission Frequency (MHz)	Factual Level Horizontal (dBm)	Factual Level Vertical (dBm)	Limits (dBm)	Min. Margin (dB)
Test mode: TX 645.000 MHz				
48.651	-67.7	-64.3	-13.0	51.3
1290.000	-59.7	-50.8	-13.0	37.8
4515.000	-57.6	-47.3	-13.0	34.3
5160.000	-53.8	-48.6	-13.0	35.6
Test mode: TX 660.000 MHz				
48.651	-68.5	-65.6	-13.0	52.6
1320.000	-62.9	-54.1	-13.0	41.1
3960.000	-57.1	-47.8	-13.0	34.8
4620.000	-44.3	-44.8	-13.0	31.3
Test mode: TX 674.700 MHz				
48.651	-65.9	-66.2	-13.0	52.9
4722.900	-50.3	-43.5	-13.0	30.5
5397.600	-49.4	-45.6	-13.0	32.6

Remarks: The measurements greater than 40dB below the limit are not report.

TEST RESULTS: The unit does meet the FCC requirements.

6.2.2.Occupied Bandwidth

Test Requirement: FCC CFR 47 Part 74.e) 5) & 6)
 Test Method: FCC CFR 47 Part 2.1049
 Test Date: April 6, 2012

Test Requirement:

- (e) For low power auxiliary stations operating in the bands allocated for TV broadcasting, the following technical requirements apply:
 - (5) The operating bandwidth shall not exceed 200 kHz.
 - (6) The mean power of emissions shall be attenuated below the mean output power of the transmitter in accordance with the following schedule:
 - (i) On any frequency removed from the operating frequency by more than 50 percent up to and including 100 percent of the authorized bandwidth: at least 25dB;
 - (ii) On any frequency removed from the operating frequency by more than 100 percent up to and including 250 percent of the authorized bandwidth: at least 35dB;
 - (iii) On any frequency removed from the operating frequency by more than 250 percent of the authorized bandwidth: at least $43+10\log_{10}$ (mean output power in watts) dB.

Test Procedure

- (a) The test item was connected to a spectrum analyzer through 40 dB of attenuation. The unmodulated carrier signal level was measured and recorded.
- (b) The test item was modulated with a 15 kHz sine wave at an input level necessary to produce 85% of the rated system deviation.
- (c) The test item was modulated with a 2500 Hz sine wave at an input level 16 dB greater than that necessary to produce 50% of the rated system deviation.

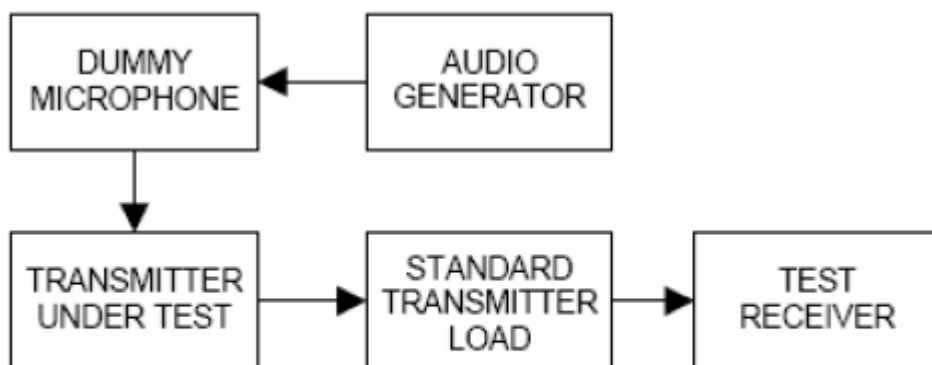

Test Result: The unit does meet the FCC requirements.

The plots of the occupied bandwidth measured are presented as below. The limits, shown on the plots, are referenced to the power measured from the unmodulated carrier, the power when modulated with the 15 kHz sine wave at 85% of the maximum deviation and when modulated with a 2500 Hz sine wave at an input 16dB greater than that necessary to produce 50% of the rated deviation.

As can be seen from the data, the test items met all occupied bandwidth requirements

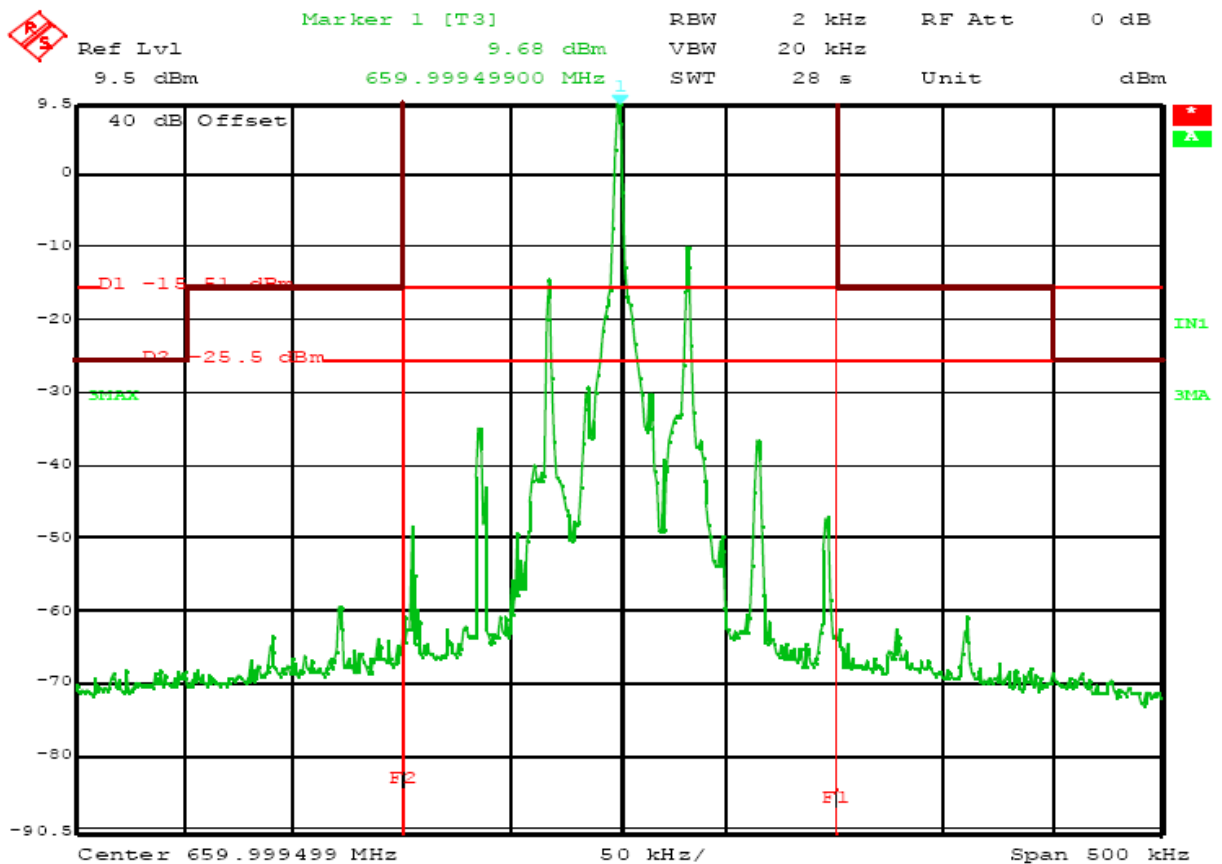

TEST MODE : Tx 660.000MHz
 TEST PARAMETERS : Unmodulated Carrier

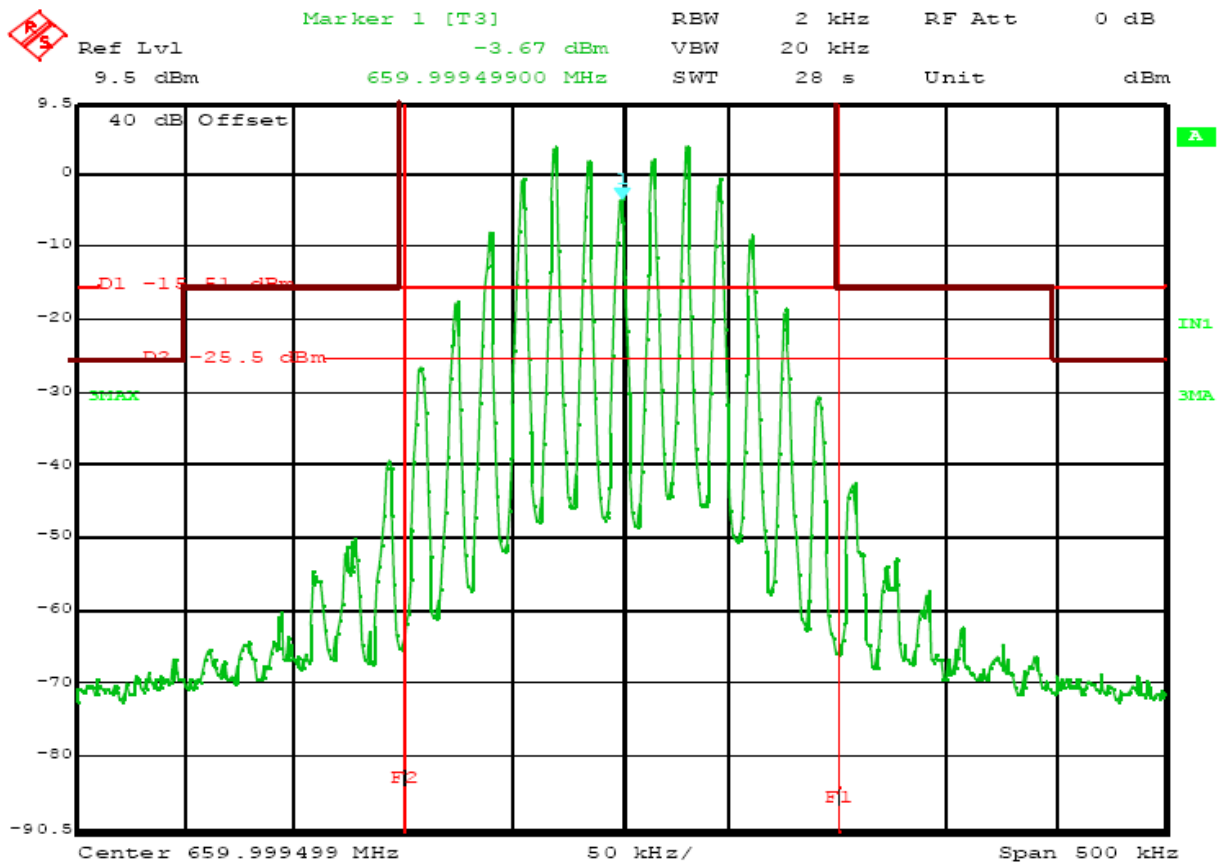

TEST MODE : Tx 660.000MHz

TEST PARAMETERS : 15kHz @ 85% Modulation

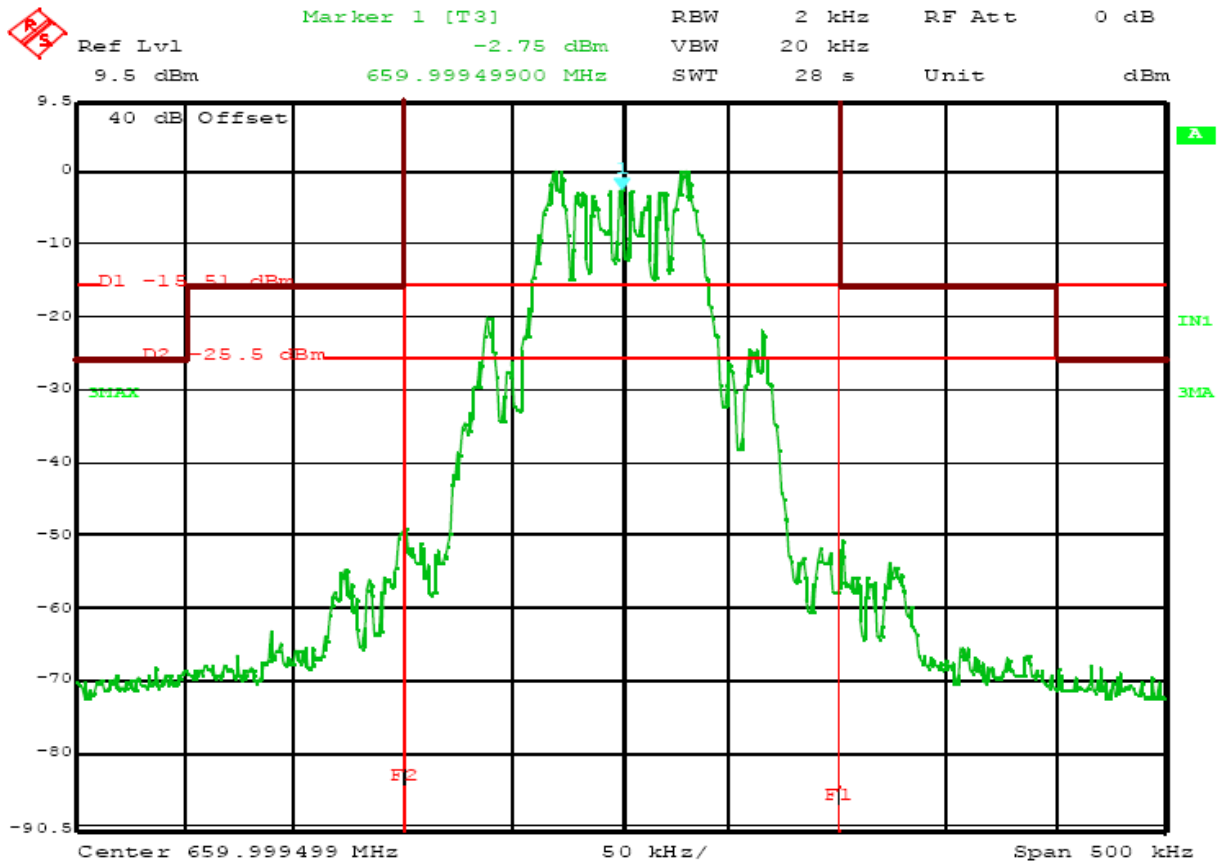

TEST MODE : Tx 660.000MHz
TEST PARAMETERS : 16dB > 50% Modulation

6.2.3.Frequency Stability

Test Requirement: FCC CFR 47 Part 74.e) 4)
 Test Method: FCC CFR 47 Part 2.1055
 Test Date: April 6, 2012
 Requirements: +/-50 ppm

(e) For low power auxiliary stations operating in the bands allocated for TV broadcasting, the following technical requirements apply:

(4) The frequency tolerance of the transmitter shall be 0.005 percent.

Test Procedure:

Frequency stability versus Environmental Temperature

The equipment under test was connected to an external DC power supply and the RF output was connected to a frequency counter via feed through attenuators. The EUT was placed inside the temperature chamber. After the temperature stabilized for approximately 20 minutes, the frequency of the output signal was recorded from the counter.

Frequency Stability versus Input Voltage

At room temperature (25±5°C), an external variable DC power supply was connected to the EUT. The frequency of the transmitter was measured for 115%, 100% and 85% of the nominal operating input voltage. For hand carried, battery powered equipment, reduce primary supply voltage to the battery operating end point which shall be specified by the manufacturer.

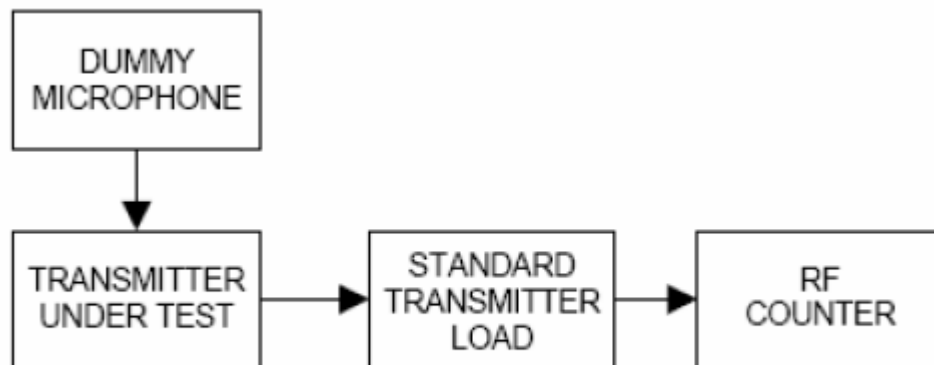

Test Result:

Assigned Frequency: 660.000 MHz		
Environment Temperature (°C)	Power Supplied (Vdc)	Frequency Measure with Time Elapsed Total emission within Max +/- 33.0kHz (kHz)
50	3.0	-8.3
40	3.0	-5.7
30	3.0	-1.1
20	3.0	-0.5
10	3.0	+0.6
0	3.0	+0.9
-10	3.0	+3.8
-20	3.0	+6.2
-30	3.0	+7.4
Environment Temperature (°C)	Power Supplied (Vdc)	Frequency Measure with Time Elapsed Total emission within Max +/- 33.0kHz (kHz)
25	2.55	-2.6
25	3.45	-2.1

The results: The unit does meet the FCC requirements.

6.2.4.Modulation Characteristics

Test Requirement: FCC CFR 47 Part 74.e) 3)
 Test Method: FCC CFR 47 Part 2.1047
 Test Date: April 6, 2012

Requirements:

- (e) For low power auxiliary stations operating in the bands allocated for TV broadcasting, the following technical requirements apply:
- (3) Any form of modulation may be used. A maximum deviation of ± 75 kHz is permitted when frequency modulation is employed.

Test Procedure:

The output of the antenna port of the test item was connected to modulation analyzer. An audio generator was connected to an audio input of the test item.

- (a) The test item was modulated with a 1000 Hz modulating signal at 60% of the test items rated frequency deviation.
- (b) The level of the audio generator was increased by 20 dB in one step.
- (c) The instantaneous and steady state positive peak deviations were recorded.
- (d) Using the audio generator level obtained in step (b) the frequency range from 20Hz to 20000 Hz was slowly swept and the maximum frequency deviation recorded at several frequencies.

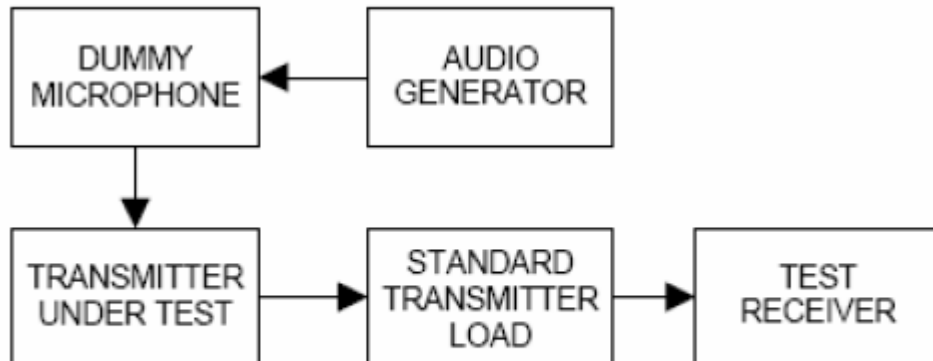

Test Result: The unit does meet the FCC requirements.

The plots of the occupied bandwidth measured are presented as below.

