



4, Songjuro236Beon-gil, Yangji-myeon, Cheoin-gu Yong-in-si,
Gyeonggi-do, Korea 17159
Tel: +82-31-323-6008 Fax: +82-31-323-6010
<http://www.ltalab.com>

Dates of Tests: February 11, 2025 ~ March 21, 2025
Test Site : LTA CO., LTD.

CERTIFICATION OF COMPLIANCE

FCC ID.

UDCCHR1356LR-8HT

APPLICANT

CEYON TECHNOLOGY CO.,LTD.

Equipment Class	:	Part 15 Low Power Communication Device Transmitter(DXX)
Manufacturing Description	:	factory automation
Manufacturer	:	CEYON TECHNOLOGY CO.,LTD.
Model name	:	CHR1356LR-8HT
Test Device Serial No.:	:	Identical prototype
Rule Part(s)	:	FCC Part 15 Subpart C ; ANSI C63.10 - 2013
Frequency Range	:	13.56 MHz
Data of issue	:	March 21, 2025

This test report is issued under the authority of:

The test was supervised by:

Eun-Hwan Jung, Manager

Jae-Humm Yeon, Test Engineer

TABLE OF CONTENTS

1. GENERAL INFORMATION ----- 3

2. INFORMATION ABOUT TEST ITEM ----- 4

3. TEST REPORT ----- 5

 3.1 SUMMARY OF TESTS ----- 5

 3.2 TECHNICAL CHARACTERISTICS TEST ----- 6

 3.2.1 Radiated Emission ----- 6

 3.2.2 Frequency Tolerance ----- 11

 3.2.3 20dB Bandwidth ----- 12

 3.2.4 AC Conducted Emissions ----- 14

APPENDIX

 APPENDIX TEST EQUIPMENT USED FOR TESTS ----- 16

1. General information

1-1 Test Performed

Company name : LTA Co., Ltd.
 Address : 243, Jubug-ri, Yangji-Myeon, Youngin-Si, Kyunggi-Do, Korea. 17159
 Web site : <http://www.ltalab.com>
 E-mail : chahn@ltalab.com
 Telephone : +82-31-323-6008
 Facsimile : +82-31-323-6010

Quality control in the testing laboratory is implemented as per ISO/IEC 17025 which is the “General requirements for the competents of calibration and testing laboratory”.

1-2 Accredited agencies

LTA Co., Ltd. is approved to perform EMC testing by the following agencies:

Agency	Country	Accreditation No.	Validity	Reference
	KOREA		-	
RRA	U.S.A	KR0049	2025-03-29	RRA accredited Lab.
	CANADA		2024-08-15	
		C-14948	2026-09-10	
VCCI	JAPAN	T-12416	2026-09-10	VCCI registration
		R-14483	2026-10-15	
		G-10847	2024-12-13	
KOLAS	KOREA	KT551	2025-10-12	KOLAS accredited Lab.

2. Information about test item

2-1 Client & Manufacturer

Client Company name : CEYON TECHNOLOGY CO.,LTD.
 Address : 13F Samsung Insurance B/D. #942-9, Ingye-Dong, Paldal-Gu, Suwon-
 City Gyeonggi-do South of Korea
 Tel / Fax : TEL No : +82-31-223-0003 / FAX No : +82-31-223-0003
 Manufacturer : CEYON TECHNOLOGY CO.,LTD.
 Address : 13F Samsung Insurance B/D. #942-9, Ingye-Dong, Paldal-Gu, Suwon-
 City Gyeonggi-do South of Korea
 Tel / Fax : TEL No : +82-31-223-0003 / FAX No : +82-31-223-0003

2-2 Equipment Under Test (EUT)

Model name : CHR1356LR-8HT
 Serial number : Identical prototype
 Date of receipt : February 11, 2025
 EUT condition : Pre-production, not damaged
 Antenna type : Pattern Antenna
 Frequency Range : 13.56 MHz
 Type of Modulation : FSK
 Power Source : DC 5 V

2-3 Tested frequency

	LOW	MID	HIGH
Frequency (MHz)		13.56	

2-4 Ancillary Equipment

Equipment	Model No.	Serial No.	Manufacturer
Notebook	-	MS-1736	MSI

3. Test Report

3.1 Summary of tests

FCC Part Section(s)	Parameter	Test Condition	Status (note 1)
15.209 15.225(a)(b)(c)(d)	Radiated Emission	Radiated	C
15.225(e)	Frequency Tolerance		C
15.215(c)	20dB Bandwidth		C
15.207	AC Conducted Emissions	Conducted	N/A
15.203	Antenna requirement	-	C

N/A : This product is battery-enabled and excludes the test.

The above equipment was tested by LTA Co., Ltd. The test data, data evaluation, test procedures, and equipment configurations shown in this report were made in accordance with the procedures given in ANSI C63.10-2013 and the energy emitted by the sample EUT tested as described in this report is in compliance with the requirements of FCC Rules Part 2 and Part 15.247 The test results of this report relate only to the tested sample identified in this report.

The tests were performed according to the method of measurements prescribed in KDB No.558074.

→ Antenna Requirement

CEYON TECHNOLOGY CO.,LTD. FCC ID: UDCCHR1356LR-8HT unit complies with the requirement of §15.203. The antenna type is Pattern Antenna

3.2 Technical Characteristics Test

3.2.1 Radiated Spurious Emissions

Procedure:

Radiated emissions from 30 MHz to 25 GHz were measured according to the methods defines in ANSI C63.10-2013.

The EUT is a placed on as turn table. For emissions testing at or below 1 GHz, the table height shall be 0.8 m above the reference ground plane. For emission measurements above 1 GHz, the table height shall be 1.5 m. The turn table shall rotate 360 degrees to determine the position of maximum emission level. EUT is set 3m away from the receiving antenna which varied from 1m to 4m to find out the highest emission. And also, each emission was to be maximized by changing the polarization of receiving antenna both horizontal and vertical. In order to find out the max. emission, the relative positions of this hand-held transmitter (EUT) was rotated through three orthogonal axes and measurement procedures for electric field radiated emissions above 1 GHz the EUT measurement is to be made “while keeping the antenna in the ‘cone of radiation’ from that area and pointed at the area both in azimuth and elevation, with polarization oriented for maximum response.” is still within the 3dB illumination BW of the measurement antenna.

The spectrum analyzer is set to:

Center frequency = the worst channel

Frequency Range = 9 kHz ~ 10th harmonic.

RBW = 120 kHz (30 MHz ~ 1 GHz)

VBW \geq RBW

= 1 MHz (1 GHz ~ 10th harmonic)

Trace = max hold

Detector function = peak

Sweep = auto

below 30 MHz

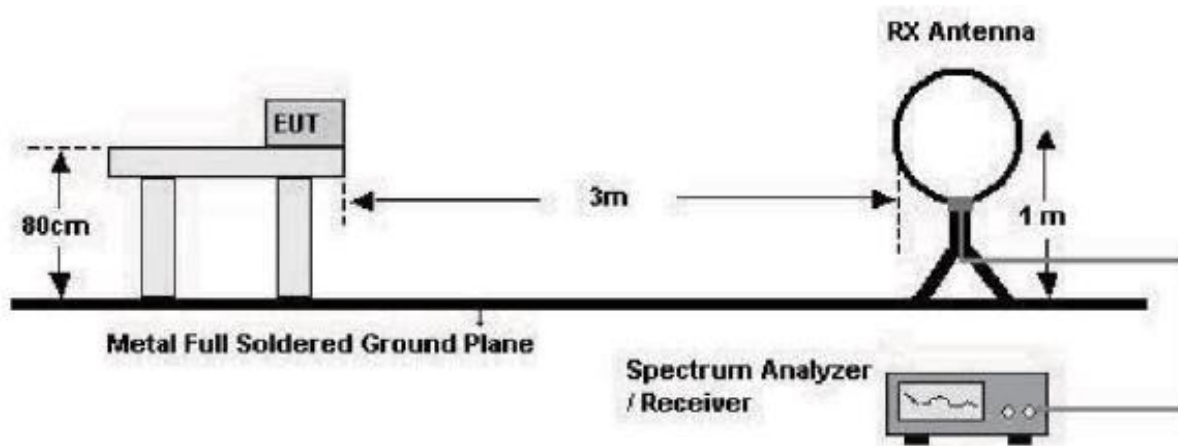

below 1 GHz (30 MHz to 1 GHz)

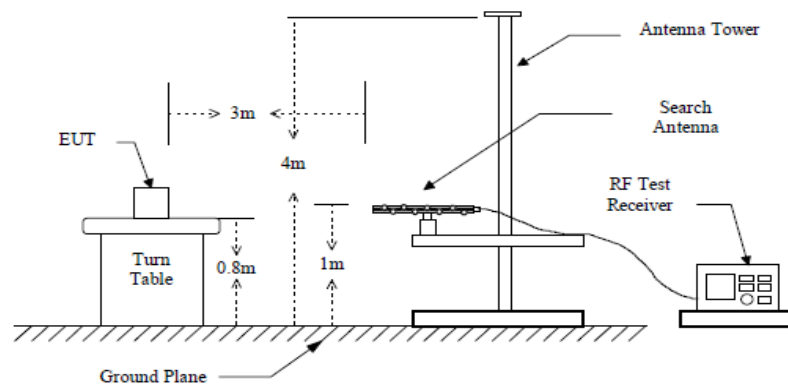

above 1 GHz

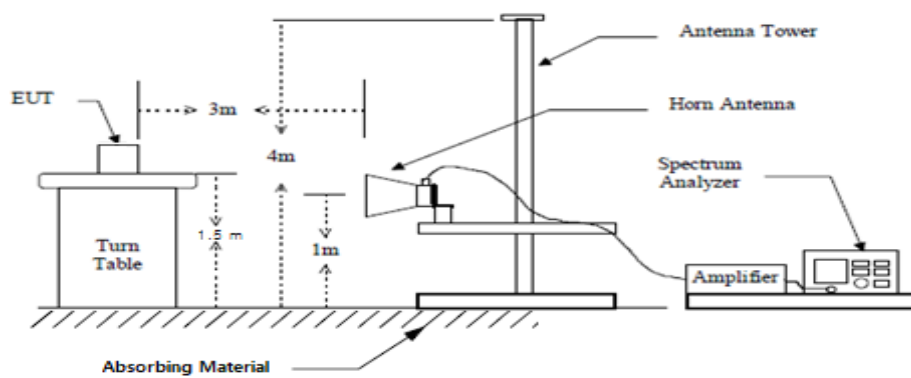

Measurement Data: Complies

- See next pages for actual measured data.
- No other emissions were detected at a level greater than 20 dB below limit include from 9 kHz to 30MHz.
- The test results for the worst of the various operating modes are presented in accordance with 6.3.4 of ANSI C63.10.
- Checked with a red circle is the fundamental frequency.

Minimum Standard: FCC Part 15.209(a)

Frequency (MHz)	Limit (uV/m) @ 3 m
0.009 ~ 0.490	2400/F(kHz) (@ 30 m)
0.490 ~ 1.705	24000/F(kHz) (@ 30 m)
1.705 ~ 30	30(@ 30 m)
30 ~ 88	100 **
88 ~ 216	150 **
216 ~ 960	200 **
Above 960	500

** Except as provided in 15.209(g), fundamental emissions from intentional radiators operating under this Section shall not be located in the frequency bands 54-72 MHz, 76-88 MHz, 174-216 MHz or 470-806 MHz. However, operation within these frequency bands is permitted under other sections of this Part, e.g. 15.231 and 15.241.

Radiated Emissions

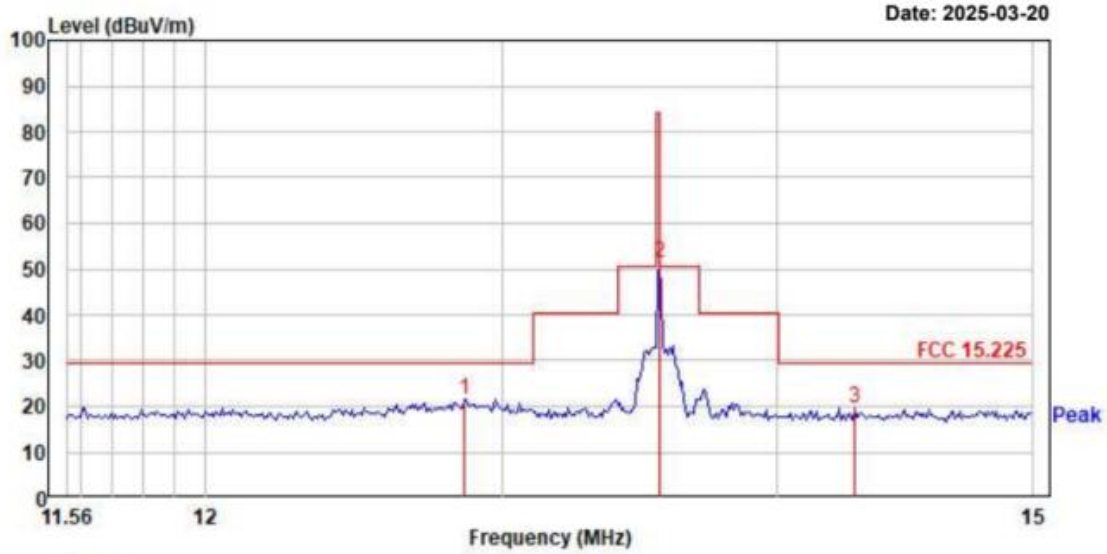

Trace:									
No.	Freq	Reading	C.F	Result	Limit	Margin	Height	Angle	Polarity
	MHz	dBμV	dB	QP	dBμV/m	dB	cm	deg	
1.	12.87	28.79	-7.11	21.68	29.54	7.86	-----	-----	vertical
2.	13.56	58.43	-7.09	51.34	84.00	32.66	-----	-----	vertical
3.	14.30	26.79	-7.06	19.73	29.54	9.81	-----	-----	vertical

Remarks: C.F (Correction Factor) = Antenna factor + Cable loss - Preamp gain

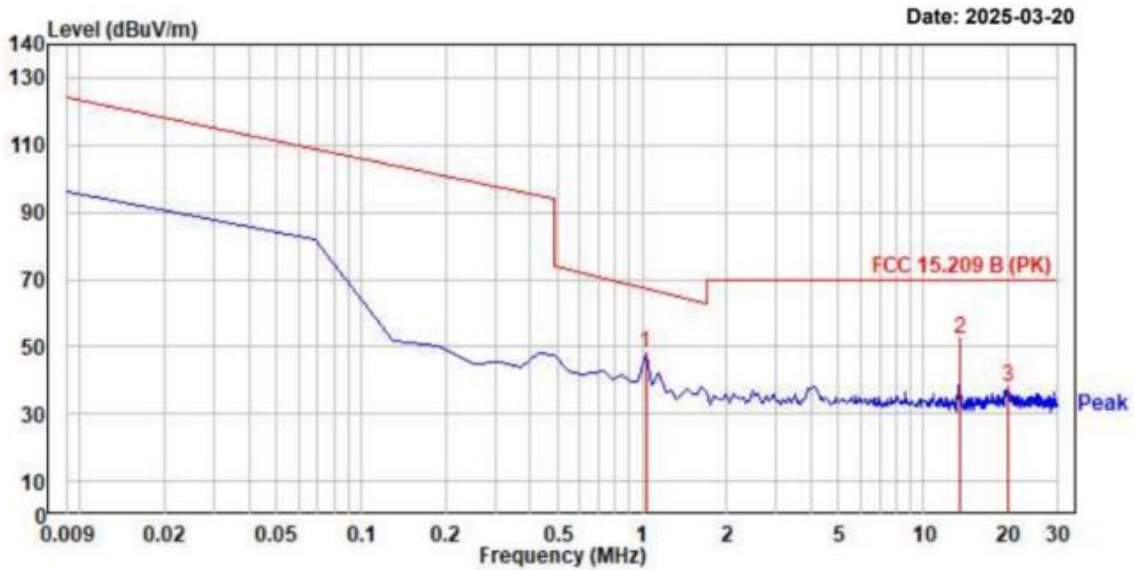

Trace:									
No.	Freq	Reading	C.F	Result	Limit	Margin	Height	Angle	Polarity
	MHz	dBμV	dB	QP	dBμV/m	dB	cm	deg	
1.	1.03	55.70	-7.79	47.91	67.46	19.55	-----	-----	vertical
2.	13.56	59.30	-7.09	52.21	70.00	17.79	-----	-----	vertical
3.	20.04	44.56	-6.70	37.86	70.00	32.14	-----	-----	vertical

Remarks: C.F (Correction Factor) = Antenna factor + Cable loss - Preamp gain

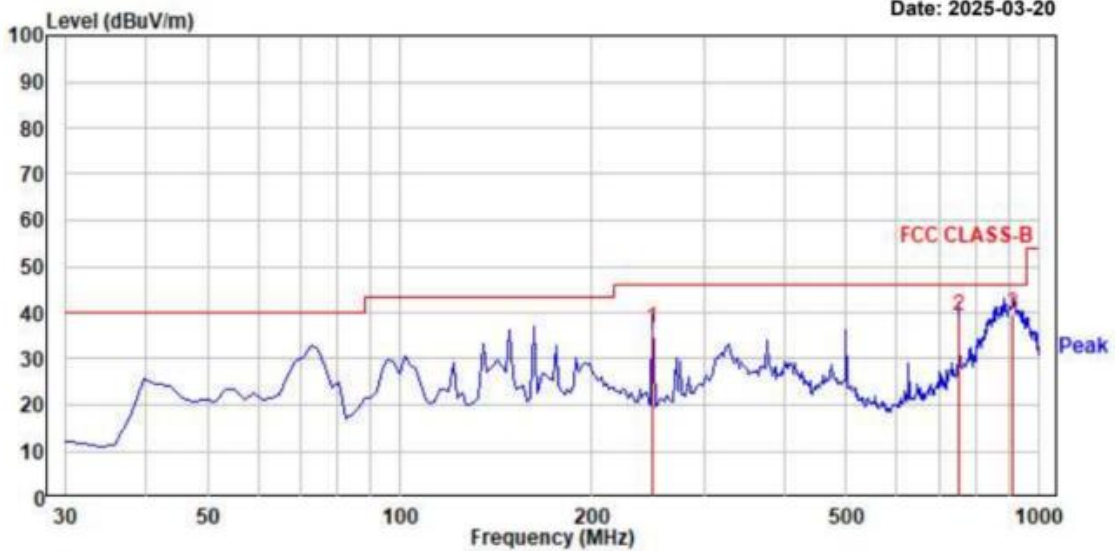

Trace:									
No.	Freq MHz	Reading dBμV	C.F dB	Result QP dBμV/m	Limit dBμV/m	Margin dB	Height cm	Angle deg	Polarity
1.	249.22	48.55	-11.88	36.67	46.00	9.33	-----	-----	horizontal
2.	749.74	38.70	0.56	39.26	46.00	6.74	-----	-----	horizontal
3.	912.70	36.78	2.69	39.47	46.00	6.53	-----	-----	horizontal

Remarks: C.F (Correction Factor) = Antenna factor + Cable loss - Preamp gain

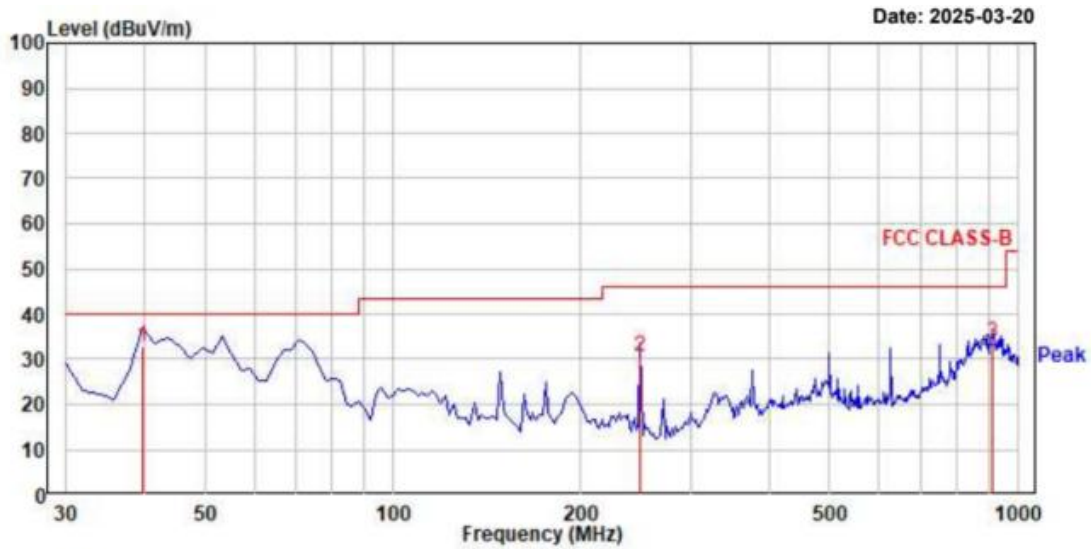

Trace:									
No.	Freq MHz	Reading dBμV	C.F dB	Result QP dBμV/m	Limit dBμV/m	Margin dB	Height cm	Angle deg	Polarity
1.	39.70	46.41	-13.53	32.88	40.00	7.12	-----	-----	vertical
2.	249.22	42.44	-11.88	30.56	46.00	15.44	-----	-----	vertical
3.	908.82	30.86	2.68	33.54	46.00	12.46	-----	-----	vertical

Remarks: C.F (Correction Factor) = Antenna factor + Cable loss - Preamp gain

3.2.2 Frequency Tolerance

Procedure:

According to FCC section 15.225, the devices operating in the 13.553~13.567 MHz shall maintain the carrier frequency within 0.01% of the operating frequency over the temperature variation of

-20°C to +50°C using an environmental chamber. The primary supply voltage is varied from 85% to 115% of the voltage normally at the input to the device or at the power supply terminals if cables are not normally supplied.

Measurement Data : Complies

VOLTAGE (%)	Test Conditions		Fre. Dev. (Hz)	Deviation (%)	Verdict
	Power (DC)	Temperature (°C)			
100	5	-20	87	0.0006	PASS
100		-10	96	0.0007	
100		0	66	0.0005	
100		50	50	0.0004	
85	4.25	20	106	0.0008	
115	5.75	50	114	0.0008	

Minimum Standard:

±0.01%

Measurement Setup

The EUT, which is powered by the AC Power Supply directly, is located in the Temperature Chamber. The EUT was measured by transmitter mode continuously.

3.2.3 20 dB Bandwidth

Procedure:

According to FCC section 15.215(c), the 20dB bandwidth should be contained within the frequency band designated in the rule section under which the EUT is operated, it was measured with a spectrum analyzer connected the EUT while the EUT is operating in transmission mode.

The spectrum analyzer is set to:

Center frequency = the highest, middle and the lowest channels

RBW = 1 kHz

VBW = 3 X RBW

Trace = max hold

Sweep = auto

Detector function = peak

Measurement Data : Complies

BLE Mode

Frequency (MHz)	Test Results	
	Measured Bandwidth (kHz)	Result
13.56	2.70	Complies

- See next pages for actual measured spectrum plots.

Minimum Standard:

20 dB Bandwidth ≤ 14 kHz

Measurement Setup

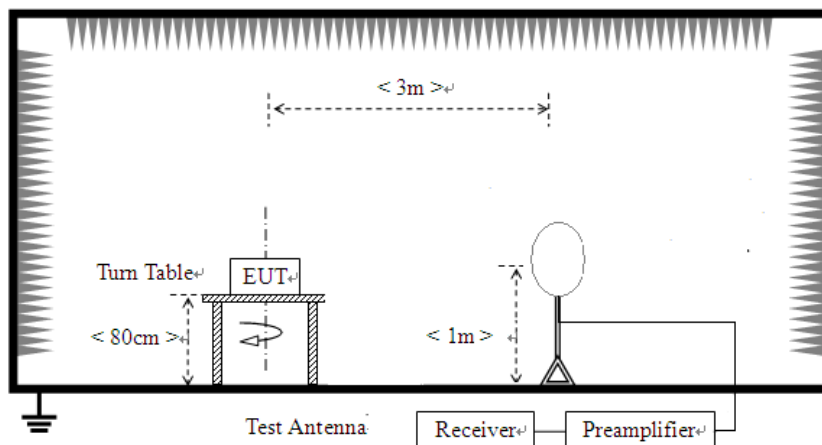



Ref 3 dBm Att 35 dB RBW 1 kHz Marker 1 [T1]
 VBW 3 kHz -26.11 dBm
 SWT 50 ms 13.560300000 MHz

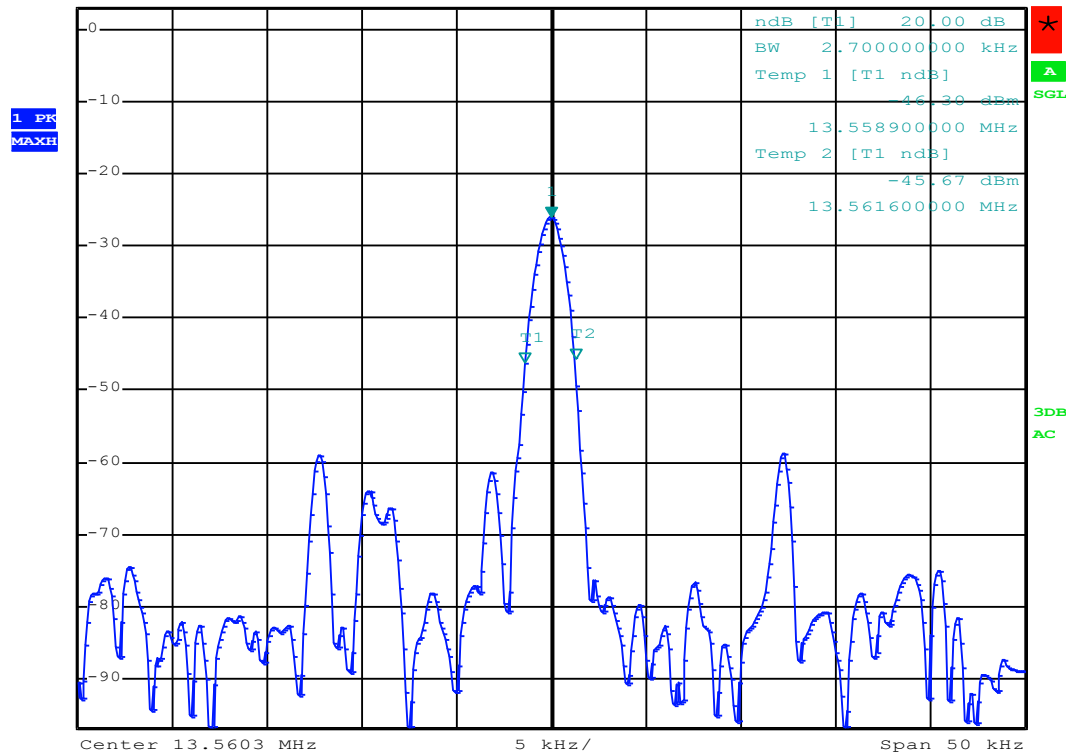

3.2.4 AC Conducted Emissions

Procedure:

The conducted emissions are measured in the shielded room with a spectrum analyzer in peak hold. While the measurement, EUT had its hopping function disabled at the middle channels in line with Section 15.31(m). Emissions closest to the limit are measured in the quasi-peak mode (QP) with the tuned receiver using a bandwidth of 9 kHz. The emissions are maximized further by cable manipulation and Exerciser operation. The highest emissions relative to the limit are listed.

Measurement Data: N/A

Class B

Frequency Range	quasi-peak	Average
0.15 ~ 0.5	66 to 56 *	56 to 46 *
0.5 ~ 5	56	46
5 ~ 30	60	50

* Decreases with the logarithm of the frequency

APPENDIX
TEST EQUIPMENT USED FOR TESTS

	Use	Description	Model No.	Serial No.	Manufacturer	Interval	Next Cal. Date
1	■	Signal Analyzer (9 kHz ~ 30 GHz)	FSV30	100757	R&S	1 year	2025-08-30
2	■	Signal Generator (~3.2 GHz)	8648C	3623A02597	HP	1 year	2026-03-08
3		SYNTHESIZED CW GENERATOR	83711B	US34490456	HP	1 year	2026-03-08
4		Attenuator (3 dB)	8491A	37822	HP	1 year	2025-08-30
5		Attenuator (10 dB)	8491A	63196	HP	1 year	2025-08-30
6	■	EMI Test Receiver (~7 GHz)	ESCI7	100722	R&S	1 year	2025-08-30
7	■	RF Amplifier (~1.3 GHz)	8447D OPT 010	2944A07684	HP	1 year	2025-08-30
8		RF Amplifier (1~26.5 GHz)	8449B	3008A02126	HP	1 year	2026-03-08
9		Horn Antenna (1~18 GHz)	3115	00114105	ETS	2 year	2025-08-30
10		DRG Horn (Small)	3116B	81109	ETS-Lindgren	2 year	2026-03-08
11		DRG Horn (Small)	3116B	133350	ETS-Lindgren	2 year	2026-03-08
12	■	TRILOG Antenna	VULB 9160	9160-3237	SCHWARZBECK	2 year	2026-03-08
13		Temp.Humidity Data Logger	SK-L200TH II A	00801	SATO	1 year	2026-03-08
14		Splitter (SMA)	ZFSC-2-2500	SF617800326	Mini-Circuits	-	-
15	■	DC Power Supply	6674A	3637A01657	Agilent	-	-
17	■	Power Meter	EPM-441A	GB32481702	HP	1 year	2026-03-08
18	■	Power Sensor	8481A	3318A94972	HP	1 year	2025-08-30
19		Audio Analyzer	8903B	3729A18901	HP	1 year	2025-08-30
20		Modulation Analyzer	8901B	3749A05878	HP	1 year	2025-08-30
21		TEMP & HUMIDITY Chamber	SJ-503H	SJ10051301	Sejong	1 year	2025-08-30
22		OSP120 BASE UNIT	OSP120	101230	R&S	1 year	2026-03-08
23		Signal Generator(100 kHz ~ 40 GHz)	SMB100A03	177621	R&S	1 year	2026-03-08
24		Signal Analyzer (10 Hz ~ 40 GHz)	FSV40	101367	R&S	1 year	2026-03-08
25	■	Active Loop Antenna	FMZB 1519	1519-031	R&S	2 year	2026-03-08
26	■	Cable	-	L-C-06	R&S	1 year	2025-06-30