



FCC 47 CFR PART 22 SUBPART H AND PART 24 SUBPART E

TEST REPORT

For

GSM Mobile phone

Model: My203L

Trade Name: SAGEM

Issued to

i-Sirius Co., Ltd

2th fl, Sam Young B/D, 106-2, Banpo-Dong, Seocho-Gu, Seoul, 137-040, Korea

Issued by

COMPLIANCE CERTIFICATION SERVICES (KUNSHAN) INC.

10#Weiye Rd, Innovation Park Eco. & Tec. Development Zone

Kunshan city JiangSu, (215300) CHINA

TEL: 86-512-57355888

FAX: 86-512-57370818



Note: This report shall not be reproduced except in full, without the written approval of Compliance Certification Services Inc. This document may be altered or revised by Compliance Certification Services Inc. personnel only, and shall be noted in the revision section of the document.



TABLE OF CONTENTS

1. TEST RESULT CERTIFICATION.....	3
2. EUT DESCRIPTION	4
3. TEST METHODOLOGY	5
EUT CONFIGURATION.....	5
EUT EXERCISE	5
GENERAL TEST PROCEDURES	5
DESCRIPTION OF TEST MODES.....	5
4. INSTRUMENT CALIBRATION.....	6
5. FACILITIES AND ACCREDITATIONS	7
FACILITIES	7
EQUIPMENT	7
TABLE OF ACCREDITATIONS AND LISTINGS	8
6. SETUP OF EQUIPMENT UNDER TEST	9
SETUP CONFIGURATION OF EUT	9
SUPPORT EQUIPMENT	9
7. FCC PART 22 & 24 REQUIREMENTS	10
PEAK POWER	10
ERP & EIRP MEASUREMENT	12
OCCUPIED BANDWIDTH MEASUREMENT	15
OUT OF BAND EMISSION AT ANTENNA TERMINALS	20
FIELD STRENGTH OF SPURIOUS RADIATION MEASUREMENT	30
FREQUENCY STABILITY V.S. TEMPERATURE MEASUREMENT.....	37
FREQUENCY STABILITY V.S. VOLTAGE MEASUREMENT.....	39
POWERLINE CONDUCTED EMISSIONS	41



1. TEST RESULT CERTIFICATION

Applicant: i-Sirius Co., Ltd
 2th fl, Sam Young B/D, 106-2, Banpo-Dong, Seocho-Gu, Seoul,
 137-040, Korea

Manufacturer: Jurong Hi-Tech(Far East) Pte Ltd.
 18, Tuas, West Avenue, 638434, Singapore

Equipment Under Test: GSM Mobile phone

Trade Name: SAGEM

Model Number: My203L

Date of Test: October 12 ~13, 2007

APPLICABLE STANDARDS	
STANDARD	TEST RESULT
FCC 47 CFR PART 22 SUBPART H AND PART 24 SUBPART E	No non-compliance noted

We hereby certify that:

The above equipment was tested by Compliance Certification Services Inc. The test data, data evaluation, test procedures, and equipment configurations shown in this report were made in accordance with the procedures given in ANSI/TIA/EIA-603-B-2002 and the energy emitted by the sample EUT tested as described in this report is in compliance with conducted and radiated emission limits of FCC Rule FCC PART 22 Subpart H and PART 24 Subpart E.

The test results of this report relate only to the tested sample identified in this report.

Approved by:

Miro Chueh
 Section Manager of Kunshan Laboratory
 Compliance Certification Services Inc.

Reviewed by:

Lin Zhang
 EMC Supervisor of Kunshan Laboratory
 Compliance Certification Services Inc.



2. EUT DESCRIPTION

Product	GSM Mobile phone
Trade Name	SAGEM
Model Number	My203L
Power Supply	1. AC to DC charger Model Number : MCW4737D-US Input: AC100-240V, 50/60Hz, 0.3A Output:DC5.0V,600mA
Frequency Range	TX: 824 ~ 849 MHz / 1850 ~ 1910 MHz RX: 869 ~ 894 MHz / 1930 ~ 1990 MHz
Transmit Power	32.51 dBm GSM 850: 32.51dBm GSM 1900: 28.99dBm
Cellular Phone Protocol	GSM (PCS)
Type of Emission	252KGXW
Antenna Type	INTERNAL Antenna

Remark: This submittal(s) (test report) is intended to comply with Part 22 and Part 24 of the FCC 47 CFR Rules.



3. TEST METHODOLOGY

Both conducted and radiated testing were performed according to the procedures document on chapter 13 of ANSI C63.4 and FCC CFR 47, 2.1046, 2.1047, 2.1049, 2.1051, 2.1053, 2.1055 and 2.1057.

EUT CONFIGURATION

The EUT configuration for testing is installed on RF field strength measurement to meet the Commissions requirement and operating in a manner that intends to maximize its emission characteristics in a continuous normal application.

EUT EXERCISE

The EUT was operated in the engineering mode to fix the TX frequency that was for the purpose of the measurements.

GENERAL TEST PROCEDURES

Conducted Emissions

The EUT is placed on the turntable, which is 0.8 m above ground plane. According to the requirements in Section 13.1.4.1 of ANSI C63.4. Conducted emissions from the EUT measured in the frequency range between 0.15 MHz and 30MHz using CISPR Quasi-peak and average detector modes.

Radiated Emissions

The EUT is placed on a turn table, which is 0.8 m above ground plane. The turntable shall rotate 360 degrees to determine the position of maximum emission level. EUT is set 3m away from the receiving antenna, which varied from 1m to 4m to find out the highest emission. And also, each emission was to be maximized by changing the polarization of receiving antenna both horizontal and vertical. In order to find out the maximum emissions, exploratory radiated emission measurements were made according to the requirements in Section 13.1.4.1 of ANSI C63.4.

DESCRIPTION OF TEST MODES

The EUT had been tested under operating condition.

EUT staying in continuous transmitting mode was programmed. Channel Low, Mid and High were chosen for full testing.

After verification, all tests were carried out with the worst case test modes as shown below except radiated spurious emission below 1GHz, which worst case was in normal link mode only.

The field strength of spurious emission was measured as EUT stand-up position (H mode) and lie-down position (E1, E2 mode) for both GSM with all power adaptors. The worst emission was found in stand-up position (H mode) and the worst case was recorded.



4. INSTRUMENT CALIBRATION

The measuring equipment, which was utilized in performing the tests documented herein, has been calibrated in accordance with the manufacturer's recommendations for utilizing calibration equipment, which is traceable to recognized national standards.



5. FACILITIES AND ACCREDITATIONS

FACILITIES

All measurement facilities used to collect the measurement data are located at CCS China Kunshan Lab at 10#, Weiye Rd, Innovation Park Eco. & Tec. Development Zone Kunshan city JiangSu, (215300)CHINA.

The sites are constructed in conformance with the requirements of ANSI C63.7, ANSI C63.4 and CISPR Publication 22.

EQUIPMENT



Radiated emissions are measured with one or more of the following types of linearly polarized antennas: tuned dipole, biconical, log periodic, bi-log, and/or ridged waveguide, horn. Spectrum analyzers with pre-selectors and quasi-peak detectors are used to perform radiated measurements.

Conducted emissions are measured with Line Impedance Stabilization Networks and EMI Test Receivers.

Calibrated wideband preamplifiers, coaxial cables, and coaxial attenuators are also used for making measurements.

All receiving equipment conforms to CISPR Publication 16-1, "Radio Interference Measuring Apparatus and Measurement Methods."

TABLE OF ACCREDITATIONS AND LISTINGS

Country	Agency	Scope of Accreditation	Logo
USA	A2LA	47 CFR FCC Part 15/18 (using ANSI C63.4:2003); VCCI V3; CNS 13438; CNS 13439; CNS 13803; CISPR 11; EN 55011; CISPR 13; EN 55013; CISPR 22:2005; CISPR 22:1997 +A1 :2000+A2 :2002; EN 55022:2006; EN55022 :1998 +A1 :2001+A2 :2003; EN 61000-6-3 (excluding discontinuous interference); EN 61000-6-4; AS/NZS CISPR 22; CAN/CSA-CEI/IEC CISPR 22; EN 61000-3-2; EN 61000-3-3; EN550024; EN 61000-4-2; EN 61000-4-3; EN61000-4-4; EN 61000-4-5; EN 61000-4-6; IEC 61000-4-8; EN 61000-4-11; IEC61000-3-2; IEC61000-3-3; IEC 61000-4-2; IEC 61000-4-3; IEC 61000-4-4; IEC 61000-4-5; IEC 61000-4-6; IEC 61000-4-8; IEC 61000-4-11; EN 300 220-3; EN 300 328; EN 300 330-2; EN 300 440-1; EN 300-440-2; EN 300 893; EN 301 489-01; EN 301 489-3; EN 301 489-07; EN 301 489-17; 47 CFR FCC Part 15, 22, 24	
USA	FCC	3/10 meter Sites to perform FCC Part 15/18 measurements	 93105, 90471
Japan	VCCI	3/10 meter Sites and conducted test sites to perform radiated/conducted measurements	VCCI R-1600 C-1707
Norway	NEMKO	EN61000-6-1/2/3/4, EN 50082-1/2, IEC 61000-6-1/2/3/4, EN 50091-2, EN 55011, EN 55022, EN 55024, EN 61000-3-2/3, EN 61000-11, IEC 61000-4-2/3/4/5/6/8/11, CISPR16-1/2/3/4	 ELA 105

** Note: No part of this report may be used to claim or imply product endorsement by A2LA or other government agency.*



6. SETUP OF EQUIPMENT UNDER TEST

SETUP CONFIGURATION OF EUT

See test photographs attached in Appendix 1 for the actual connections between EUT and support equipment.

SUPPORT EQUIPMENT

No.	Device Type	Brand	Model	FCC ID	Series No.	Data Cable	Power Cord
1	N/A						

Remark:

- 1. All the equipment/cables were placed in the worst-case configuration to maximize the emission during the test.*
- 2. Grounding was established in accordance with the manufacturer's requirements and conditions for the intended use.*



7. FCC PART 22 & 24 REQUIREMENTS

PEAK POWER

LIMIT

According to FCC §2.1046.

MEASUREMENT EQUIPMENT USED

Name of Equipment	Manufacturer	Model	Serial Number	Calibration Due
Peak and Avg Power Sensor	Agilent	E9327A	US40441788	07/30/2008
EPM-P Series Power Meter	Agilent	E4416A	QB41292714	07/30/2008
Spectrum Analyzer	Agilent	E4446A	MY44020154	08/16/2008
Wireless communication test set	Agilent	8960	QB44051695	10/06/2008

Remark: Each piece of equipment is scheduled for calibration once a year.

Test Configuration

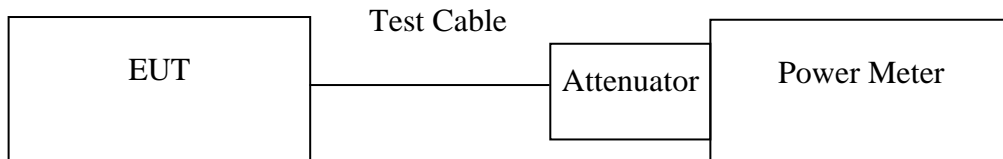

Remark: Measurement setup for testing on Antenna connector

TEST PROCEDURE

The transmitter output was connected to a calibrated attenuator, the other end of which was connected to a power meter. Transmitter output was read off the power meter in dBm. The power output at the transmitter antenna port was determined by adding the value of the attenuator to the power meter reading.



TEST RESULTS

No non-compliance noted.

Test Data

Test Mode	CH	Frequency (MHz)	Power Meter Reading (dBm)	Factor (dB)	Peak Power (dBm)
GSM 850	128	824.20	8.79	23.50	32.29
	190	836.60	9.01		32.51
	251	848.80	9.00		32.50

Remark: The value of factor includes both the loss of cable and external attenuator

Test Mode	CH	Frequency (MHz)	Power Meter Reading (dBm)	Factor (dB)	Peak Power (dBm)
GSM 1900	512	1850.20	5.39	23.50	28.89
	661	1880.00	5.49		28.99
	810	1910.00	4.71		28.21

Remark: The value of factor includes both the loss of cable and external attenuator

ERP & EIRP MEASUREMENT

LIMIT

According to FCC §2.1046

FCC 22.913(b): The Effective Radiated Power (ERP) of mobile transmitters must not exceed 7 Watts.

FCC 24.232(b): The equivalent Isotropic Radiated Power (EIRP) must not exceed 2 Watts.

MEASUREMENT EQUIPMENT USED

977 Chamber (3m)				
Name of Equipment	Manufacturer	Model	Serial Number	Calibration Due
Spectrum Analyzer	Agilent	E4446A	MY44020154	08/16/2008
EMI Test Receiver	R&S	ESPI3	101026	11/11/2007
Pre-Amplifier	MINI-circuits	ZFL-1000VH2	d041703	12/13/2007
Pre-Amplifier	Miteq	NSP4000-NF	870731	01/28/2008
Bilog Antenna	Sunol	JB1	A110204-2	11/22/2007
Horn-antenna	SCHWARZBECK	BBHA9120D	D:266	02/01/2008
PSG Analog Signal Generator	Agilent	E8257C	MY43321570	12/19/2008
Wireless communication test set	Agilent	8960	QB44051695	10/06/2008
Turn Table	CT	CT123	4165	N.C.R
Antenna Tower	CT	CTERG23	3256	N.C.R
Controller	CT	CT100	95637	N.C.R
Site NSA	CCS	N/A	N/A	04/06/2008

Remark: Each piece of equipment is scheduled for calibration once a year.

TEST CONFIGURATION

Below 1 GHz

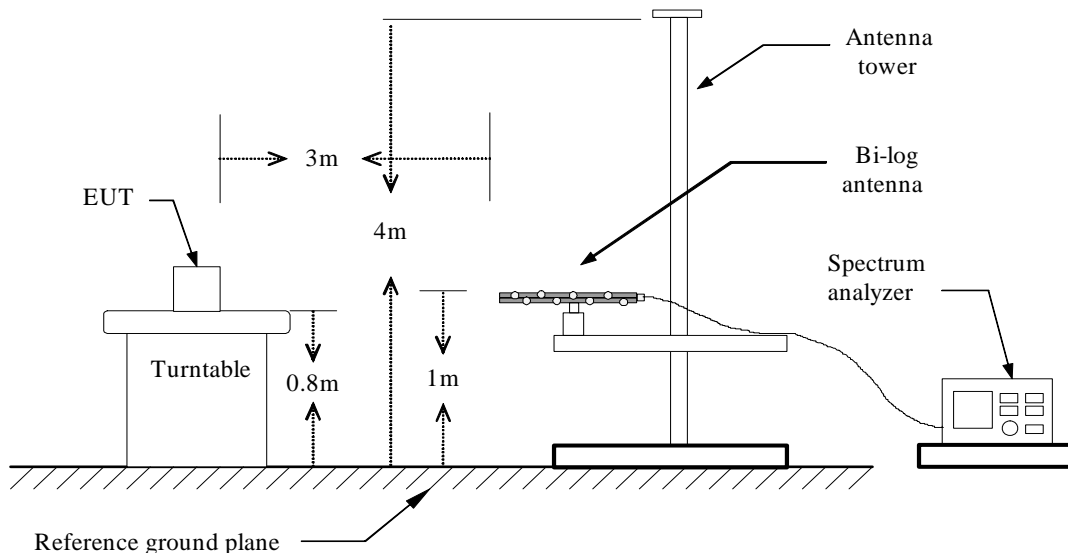

Above 1 GHz

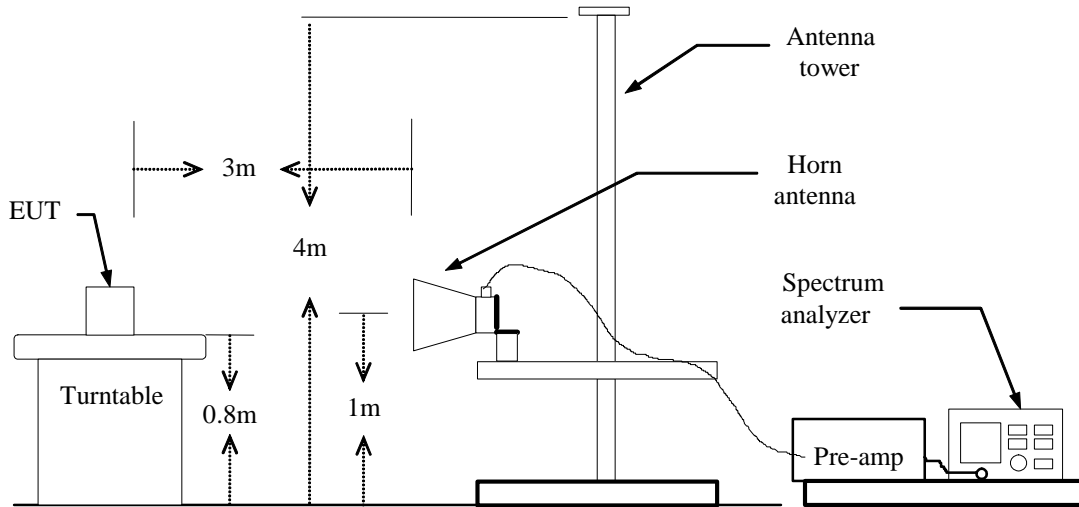

For Substituted Method Test Set-UP

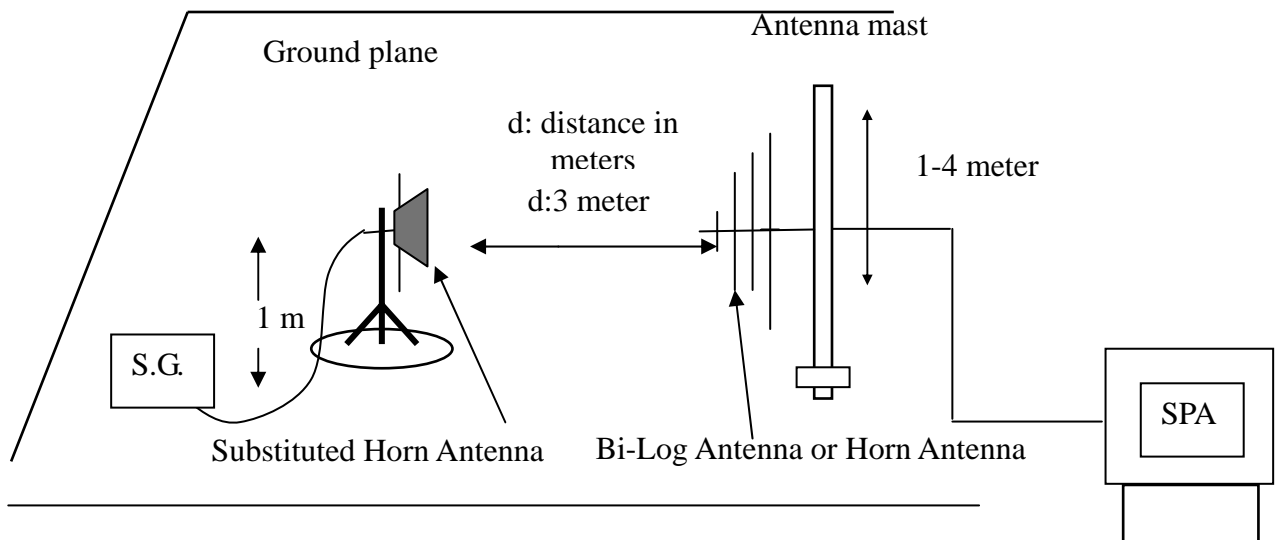

TEST PROCEDURE

The EUT was placed on an non-conductive turntable using a non-conductive support. The radiated emission at the fundamental frequency was measured at 3 m with a test antenna and EMI spectrum analyzer.

During the measurement of the EUT, the resolution bandwidth was set to 3MHz and the average bandwidth was set to 3MHz. The highest emission was recorded with the rotation of the turntable and the lowering of the test antenna. The reading was recorded and the field strength (E in dBuV/m) was calculated.

ERP in frequency band 824-849MHz, and EIRP in frequency band 1851.25 –1910MHz were measured using a substitution method. The EUT was replaced by Bi-log antenna (824-849MHz) or horn antenna (1851.25-1910MHz) connected to a signal generator. The spectrum analyzer reading was recorded and ERP/EIRP was calculated as follows:

$$ERP = \text{S.G. output (dBm)} + \text{Antenna Gain (dBd)} - \text{Cable (dB)}$$

$$EIRP = \text{S.G. output (dBm)} + \text{Antenna Gain (dBi)} - \text{Cable (dB)}$$



TEST RESULTS

No non-compliance noted.

GSM 850 Test Data

EUT Pol.	Channel	Frequency (MHz)	Reading level (dBUV)	Antenna Pol.	S.G. (dBm)	Cable loss (dB)	Ant.Gain (dBd)	Emission level (dBm)	Limit (dBm)	Margin (dB)
H	128	824.20	128.31	V	26.55	2.87	6.20	29.88	38.5	-8.62
		824.20	120.62	H	22.83	2.87	6.20	26.16	38.5	-12.34
	190	836.60	128.75	V	27.47	2.88	6.40	30.99	38.5	-7.51
		836.60	120.12	H	21.64	2.88	6.40	25.16	38.5	-13.34
	251	848.80	127.33	V	27.67	2.94	6.50	31.23	38.5	-7.27
		848.80	119.79	H	23.22	2.94	6.50	26.78	38.5	-11.72

GSM 1900 Test Data

EUT Pol.	Channel	Frequency (MHz)	Reading level (dBUV)	Antenna Pol.	S.G. (dBm)	Cable loss (dB)	Ant.Gain (dBi)	Emission level (dBm)	Limit (dBm)	Margin (dB)
H	512	1850.20	121.08	V	23.96	4.31	8.45	28.1	33	-4.9
		1850.20	120.07	H	20.15	4.31	8.45	24.29	33	-8.71
	661	1880.00	121.86	V	24.35	4.53	8.48	28.3	33	-4.7
		1880.00	120.13	H	20.92	4.53	8.48	24.87	33	-8.13
	810	1909.80	119.84	V	22.71	4.55	8.52	26.68	33	-6.32
		1909.80	120.89	H	20.76	4.55	8.52	24.73	33	-8.27



OCCUPIED BANDWIDTH MEASUREMENT

LIMIT

According to §FCC 2.1049.

MEASUREMENT EQUIPMENT USED

Name of Equipment	Manufacturer	Model	Serial Number	Calibration Due
Spectrum Analyzer	Agilent	E4446A	MY44020154	08/16/2008
Wireless communication test set	Agilent	8960	QB44051695	10/06/2008

Remark: Each piece of equipment is scheduled for calibration once a year.

Test Configuration

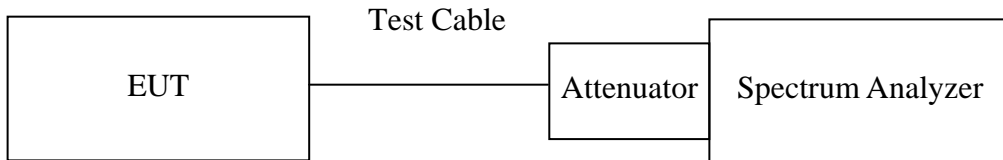

Remark: Measurement setup for testing on Antenna connector

TEST PROCEDURE

The EUT's output RF connector was connected with a short cable to the spectrum analyzer, RBW was set to about 1% of emission BW, VBW is set to 3 times the RBW, -26dBc display line was placed on the screen (or 99% bandwidth), the occupied bandwidth is the delta frequency between the two points where the display line intersects the signal trace.

The spectrum analyzer is set to: RBW = 3 kHz, VBW = 10 kHz, Span = 1 MHz, Sweep = auto



TEST RESULTS

No non-compliance noted

Test Data

Test Mode	CH	Frequency (MHz)	Occupied Bandwidth (kHz)	26dB Bandwidth (kHz)
GSM 850	128	824.20	242.07	314.722
	190	836.6	241.90	308.537
	251	848.8	242.05	310.435

Test Mode	CH	Frequency (MHz)	Occupied Bandwidth (kHz)	26 dB Bandwidth (kHz)
GSM 1900	512	1850.20	246.45	309.602
	661	1880.00	238.92	306.079
	810	1909.80	244.80	304.681



Test Plot

GSM 850 (CH Low)

Agilent 13:13:41 Oct 16, 2007

Ch Freq 824.2 MHz		Trig Free	Trace 1 2 3 Clear Write Max Hold Min Hold View Blank
Occupied Bandwidth			
Center 824.200000 MHz			
Ref 40 dBm	Atten 30 dB		
#Peak			
Log			
10			
dB/			
Offst			
23.5			
dB			
Center 824.200 MHz	Span 1 MHz		
#Res BW 3 kHz	#VBW 10 kHz	Sweep 105.4 ms (601 pts)	
Occupied Bandwidth		Occ BW % Pwr 99.00 %	
242.0723 kHz		x dB -26.00 dB	
Transmit Freq Error	261.876 Hz		
x dB Bandwidth	314.722 kHz		
File Operation Status, A:\SCREN030.GIF file saved			

GSM 850 (CH Mid)

Agilent 13:14:43 Oct 16, 2007

Ch Freq 836.6 MHz		Trig Free	Freq/Channel Center Freq 836.600000 MHz Start Freq 836.100000 MHz Stop Freq 837.100000 MHz CF Step 100.000000 kHz Auto Man Freq Offset 0.0000000 Hz Signal Track On Off
Occupied Bandwidth			
Center 836.600000 MHz			
Ref 40 dBm	Atten 30 dB		
#Peak			
Log			
10			
dB/			
Offst			
23.5			
dB			
Center 836.600 MHz	Span 1 MHz		
#Res BW 3 kHz	#VBW 10 kHz	Sweep 105.4 ms (601 pts)	
Occupied Bandwidth		Occ BW % Pwr 99.00 %	
241.8985 kHz		x dB -26.00 dB	
Transmit Freq Error	342.049 Hz		
x dB Bandwidth	308.537 kHz		
File Operation Status, A:\SCREN032.GIF file saved			



GSM 850 (CH High)

Agilent 13:15:09 Oct 16, 2007

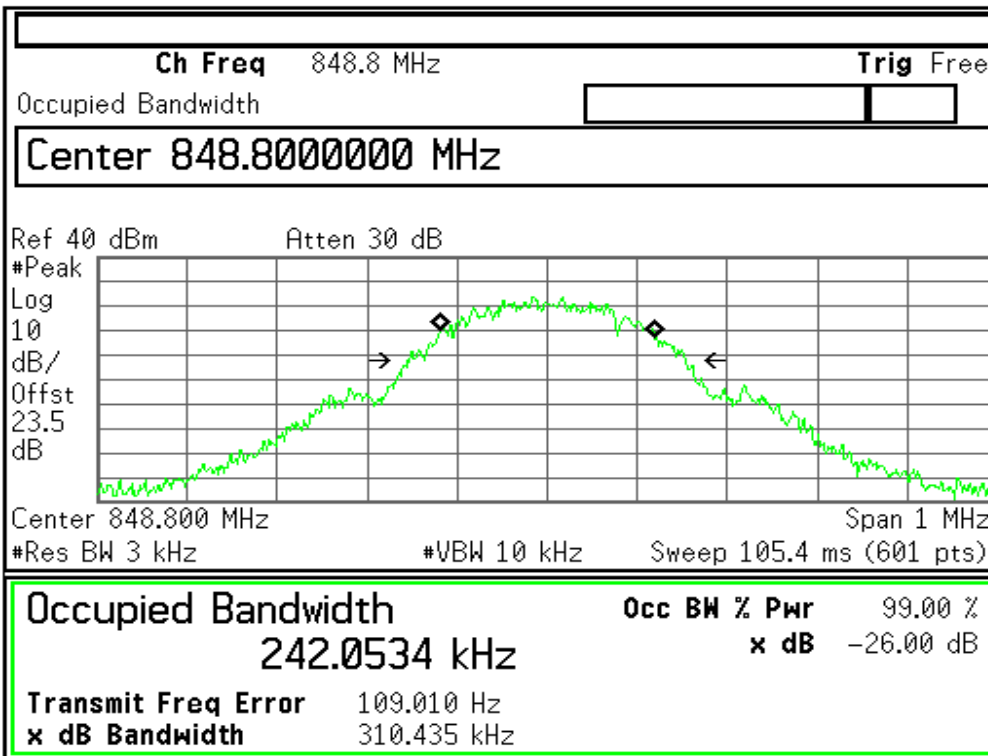

Trace		
1	Trace	3
2		
3		
Clear Write		
Max Hold		
Min Hold		
View		
Blank		

File Operation Status, A:\SCREN033.GIF file saved

GSM 1900 (CH Low)

Agilent 13:20:55 Oct 16, 2007

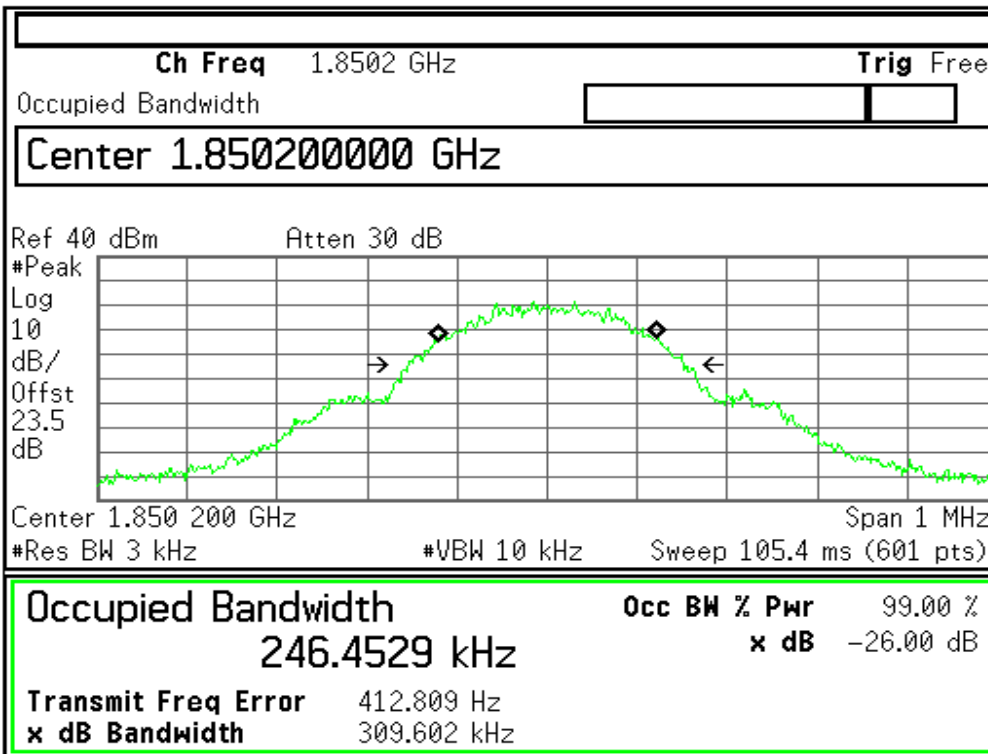

Trace		
1	Trace	3
2		
3		
Clear Write		
Max Hold		
Min Hold		
View		
Blank		

File Operation Status, A:\SCREN038.GIF file saved



GSM 1900 (CH Mid)

Agilent 13:19:43 Oct 16, 2007

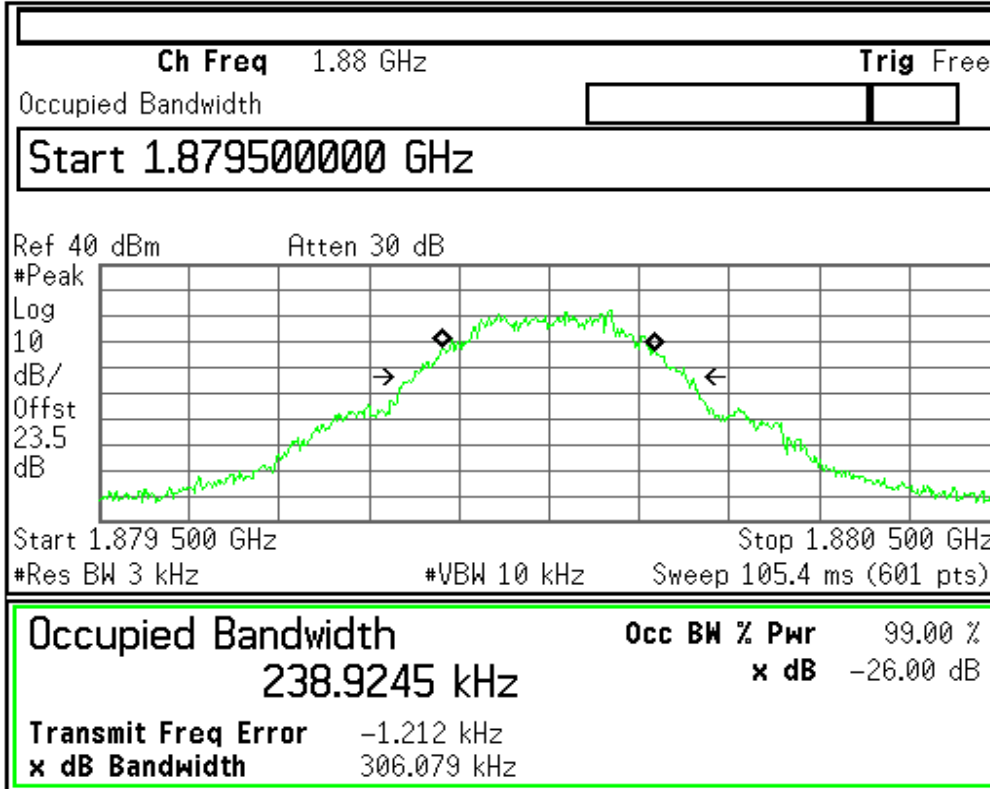

Freq/Channel	
Center Freq	1.88000000 GHz
Start Freq	1.87950000 GHz
Stop Freq	1.88050000 GHz
CF Step	100.000000 kHz Auto Man
Freq Offset	0.00000000 Hz
Signal Track	On Off

File Operation Status, A:\SCREN036.GIF file saved

GSM 1900 (CH High)

Agilent 13:18:24 Oct 16, 2007

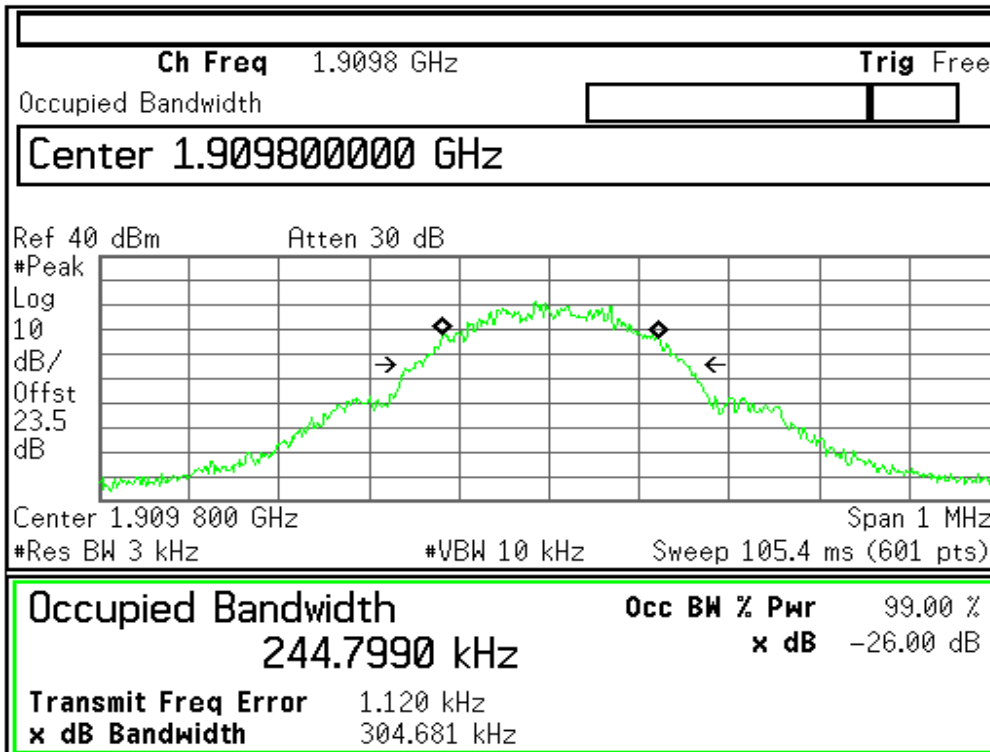

Freq/Channel	
Center Freq	1.90980000 GHz
Start Freq	1.90930000 GHz
Stop Freq	1.91030000 GHz
CF Step	100.000000 kHz Auto Man
Freq Offset	0.00000000 Hz
Signal Track	On Off

File Operation Status, A:\SCREN034.GIF file saved



OUT OF BAND EMISSION AT ANTENNA TERMINALS

LIMIT

According to FCC §2.1051, FCC §2.2917(f), FCC §22.917(f), FCC §24.238(a).

Out of Band Emissions: The mean power of emission must be attenuated below the mean power of the non-modulated carrier (P) on any frequency twice or more than twice the fundamental frequency by at least $43 + 10 \log P$ dB.

Mobile Emissions in Base Frequency Range: The mean power of any emissions appearing in the base station frequency range from cellular mobile transmitters operated must be attenuated to a level not exceed -80 dBm at the transmit antenna connector.

Band Edge Requirements: In the 1MHz bands immediately outside and adjacent to the frequency block, a resolution bandwidth of at least 1% of the emission bandwidth of the fundamental emission of the transmitter may be employed to measure the Out of band Emission

MEASUREMENT EQUIPMENT USED

Name of Equipment	Manufacturer	Model	Serial Number	Calibration Due
Spectrum Analyzer	Agilent	E4446A	MY44020154	08/16/2008
Wireless communication test set	Agilent	8960	QB44051695	10/06/2008

Remark: Each piece of equipment is scheduled for calibration once a year.

TEST CONFIGURATION

Out of band emission at antenna terminals:

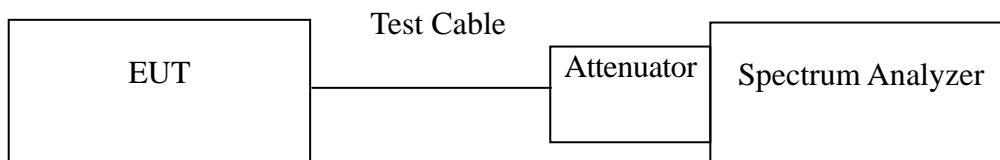

TEST PROCEDURE

The RF output of the transceiver was connected to a spectrum analyzer through appropriate attenuation. The resolution bandwidth of the spectrum analyzer was set at 1MHz, sufficient scans were taken to show the out of band Emissions if any up to 10th harmonic.

For the out of band: Set the RBW, VBW = 1MHz, Start=30MHz, Stop= 10 th harmonic. Limit = -13dBm

Band Edge Requirements (824 MHz and 849 MHz /1850MHz and 1910MHz): In the 1 MHz bands immediately outside and adjacent to the frequency block, a resolution bandwidth of at least 1 percent of the emission bandwidth of the fundamental emission of the transmitter may be employed to measure the out of band Emissions. Limit, -13dBm.

For the Band Edge: The spectrum analyzer is set to: RBW = 3 kHz, VBW = 10 kHz, Span = 1 MHz, Sweep = auto



TEST RESULTS

No non-compliance noted.

Test Data

Mode	CH	Location	Description
GSM 850	128	Figure 7-1	Conducted spurious emissions, 30MHz - 2.5GHz
		Figure 7-2	Conducted spurious emissions, 2.5GHz - 20GHz
	190	Figure 7-3	Conducted spurious emissions, 30MHz - 2.5GHz
		Figure 7-4	Conducted spurious emissions, 2.5GHz - 20GHz
	251	Figure 7-5	Conducted spurious emissions, 30MHz - 2.5GHz
		Figure 7-6	Conducted spurious emissions, 2.5GHz - 20GHz

Mode	CH	Location	Description
GSM 1900	512	Figure 8-1	Conducted spurious emissions, 30MHz - 2.5GHz
		Figure 8-2	Conducted spurious emissions, 2.5GHz - 20GHz
	661	Figure 8-3	Conducted spurious emissions, 30MHz - 2.5GHz
		Figure 8-4	Conducted spurious emissions, 2.5GHz - 20GHz
	810	Figure 8-5	Conducted spurious emissions, 30MHz - 2.5GHz
		Figure 8-6	Conducted spurious emissions, 2.5GHz - 20GHz

Mode	CH	Location	Description
GSM 850	128	Figure 9-1	Band Edge emissions
	251	Figure 9-2	Band Edge emissions

Mode	CH	Location	Description
GSM 1900	512	Figure 10-1	Band Edge emissions
	810	Figure 10-2	Band Edge emissions



Test Plot

GSM 850

Figure 7-1: Out of Band emission at antenna terminals – GSM CH Low

Agilent 13:30:52 Oct 16, 2007

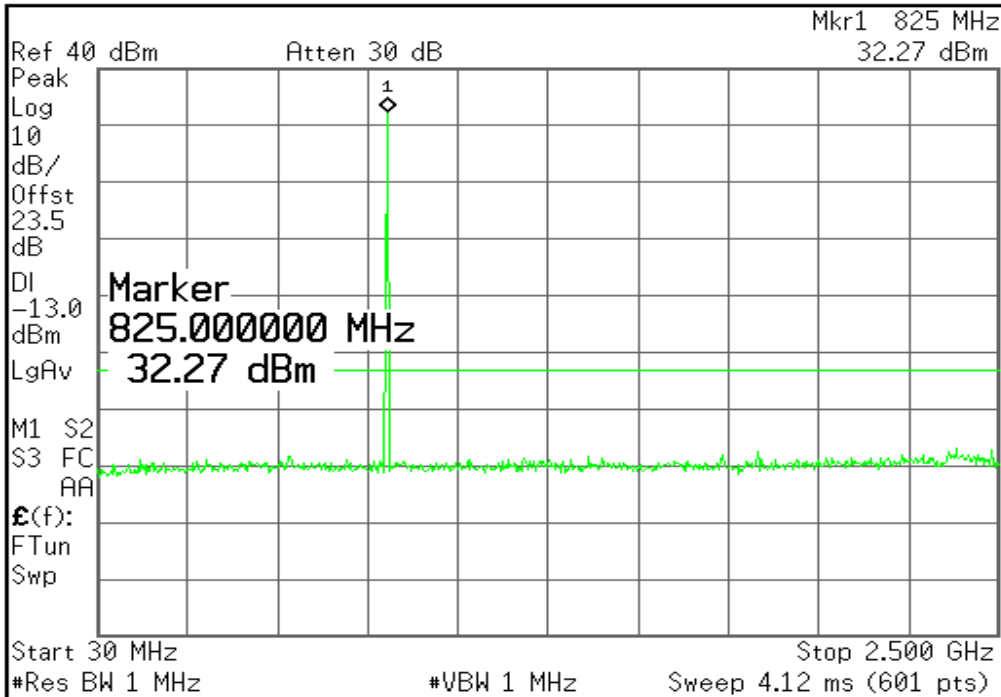

Peak Search

Next Peak

Next Pk Right

Next Pk Left

Min Search

Pk-Pk Search

Mkr → CF

More 1 of 2

File Operation Status, A:\SCREEN049.GIF file saved

Figure 7-2: Out of Band emission at antenna terminals – GSM CH Low

Agilent 13:31:15 Oct 16, 2007

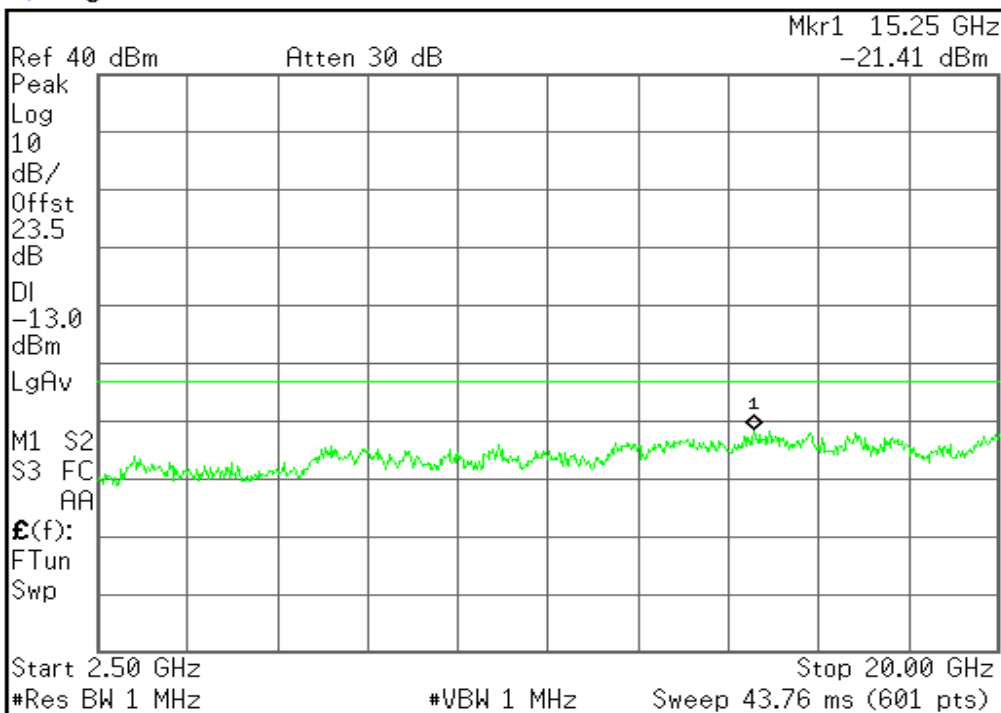

Peak Search

Next Peak

Next Pk Right

Next Pk Left

Min Search

Pk-Pk Search

Mkr → CF

More 1 of 2

Copyright 2000–2003 Agilent Technologies



Figure 7-3: Out of Band emission at antenna terminals – GSM CH Mid

Agilent 13:30:14 Oct 16, 2007

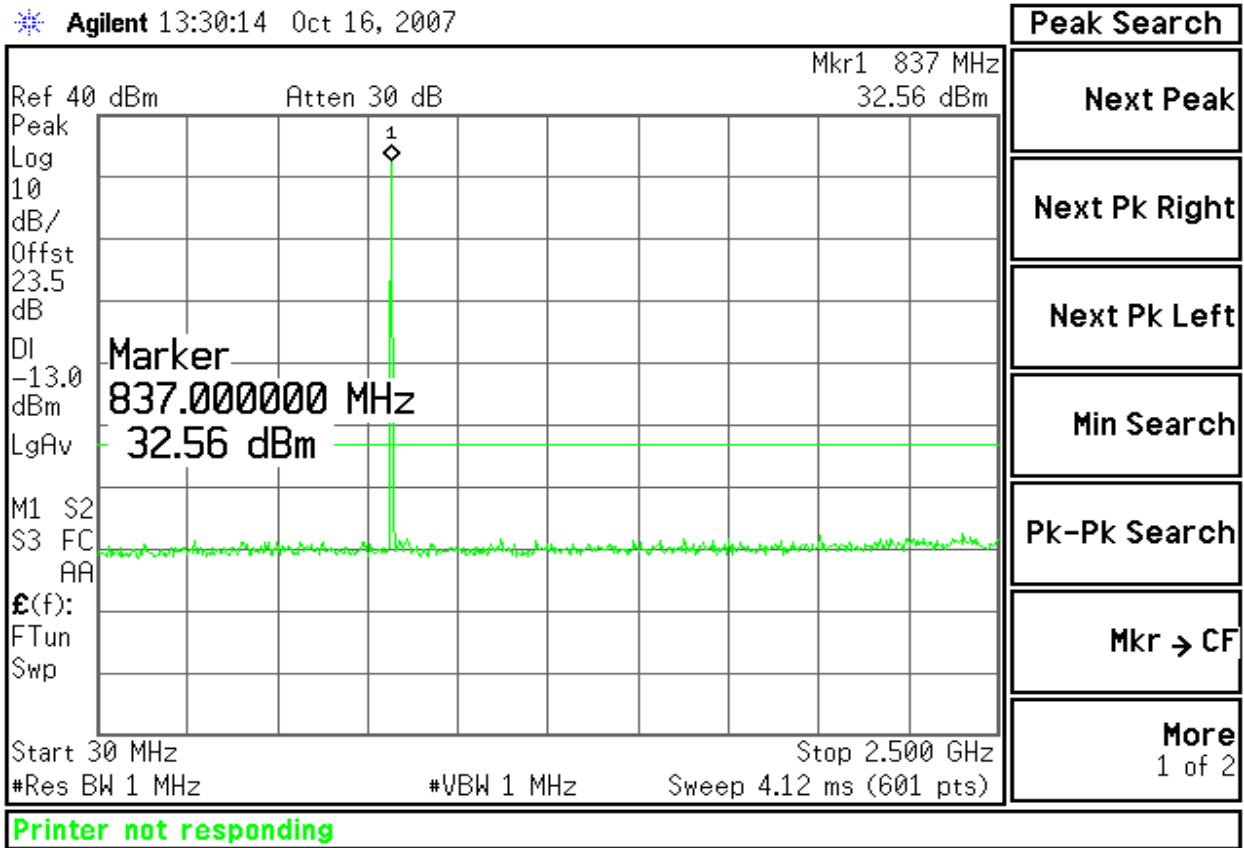

Figure 7-4: Out of Band emission at antenna terminals – GSM CH Mid

Agilent 13:39:38 Oct 16, 2007

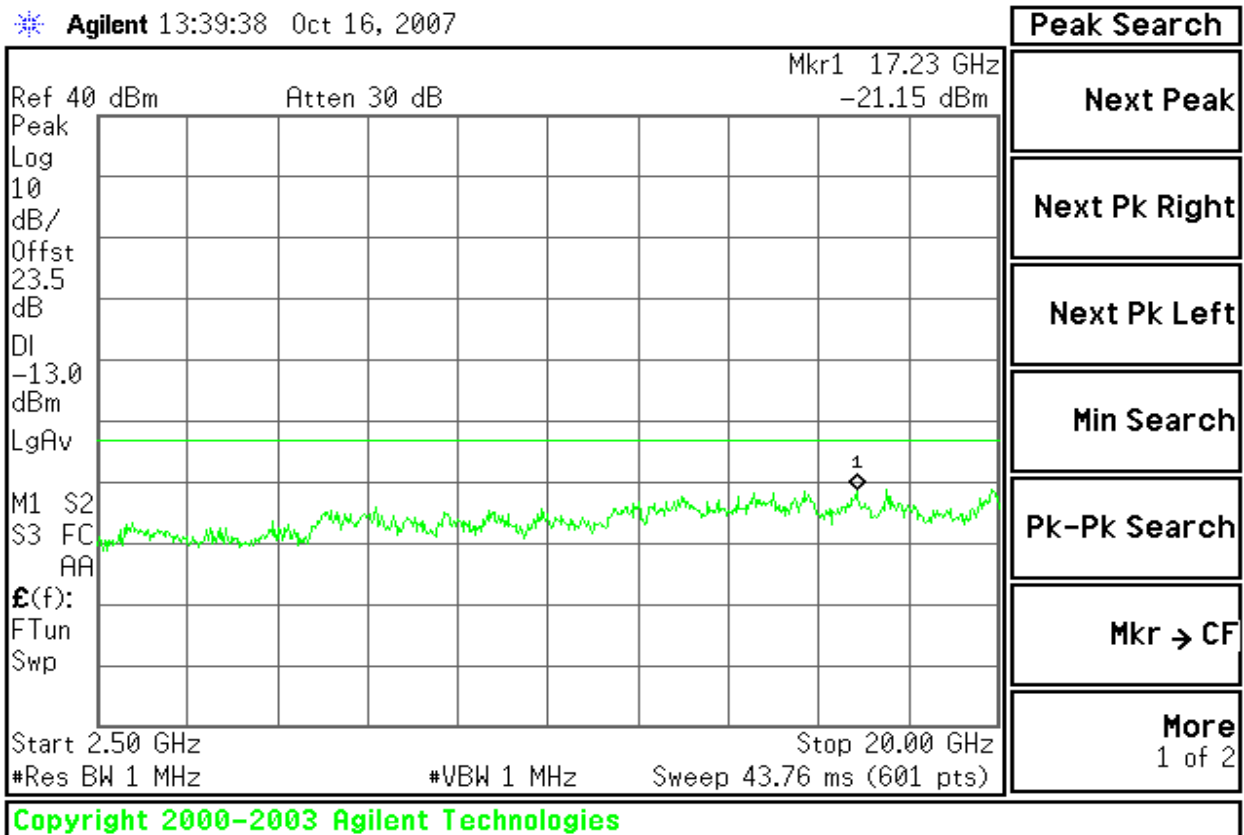



Figure 7-5: Out of Band emission at antenna terminals – GSM CH High

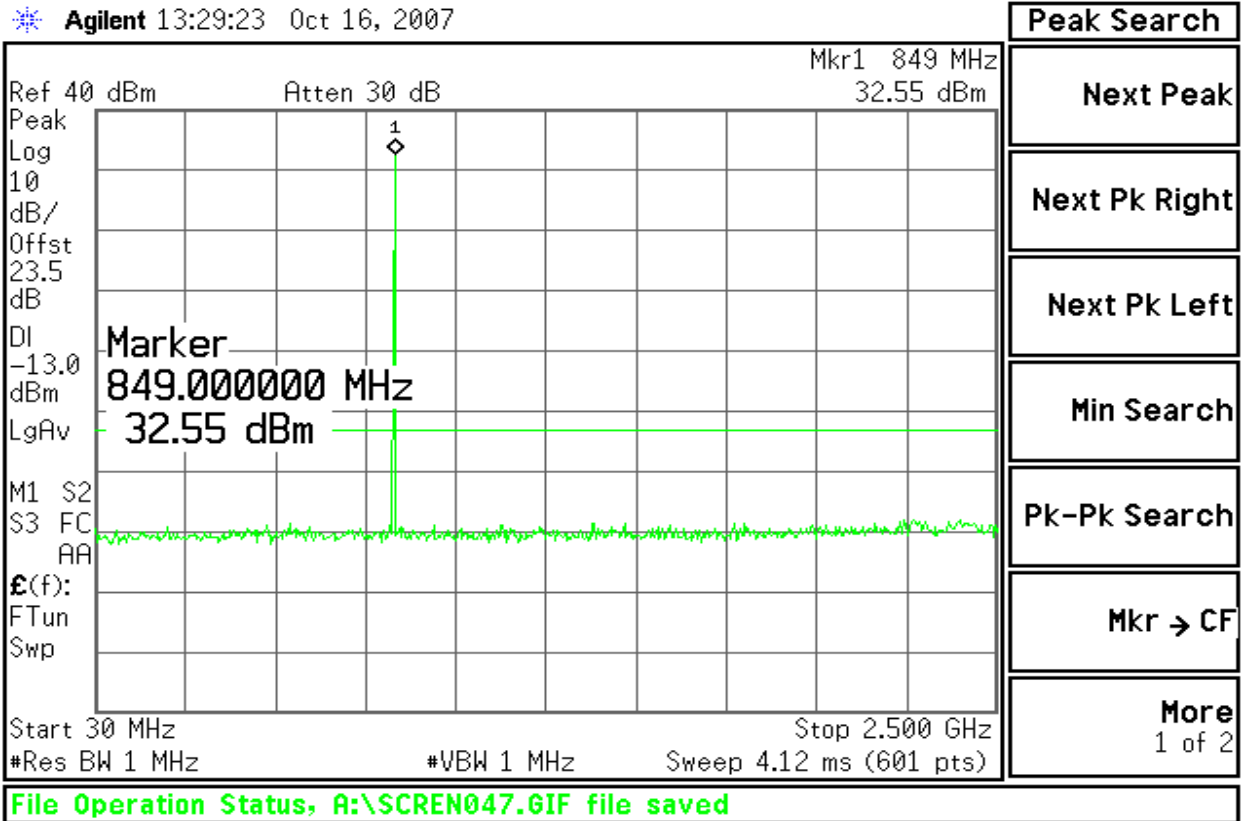
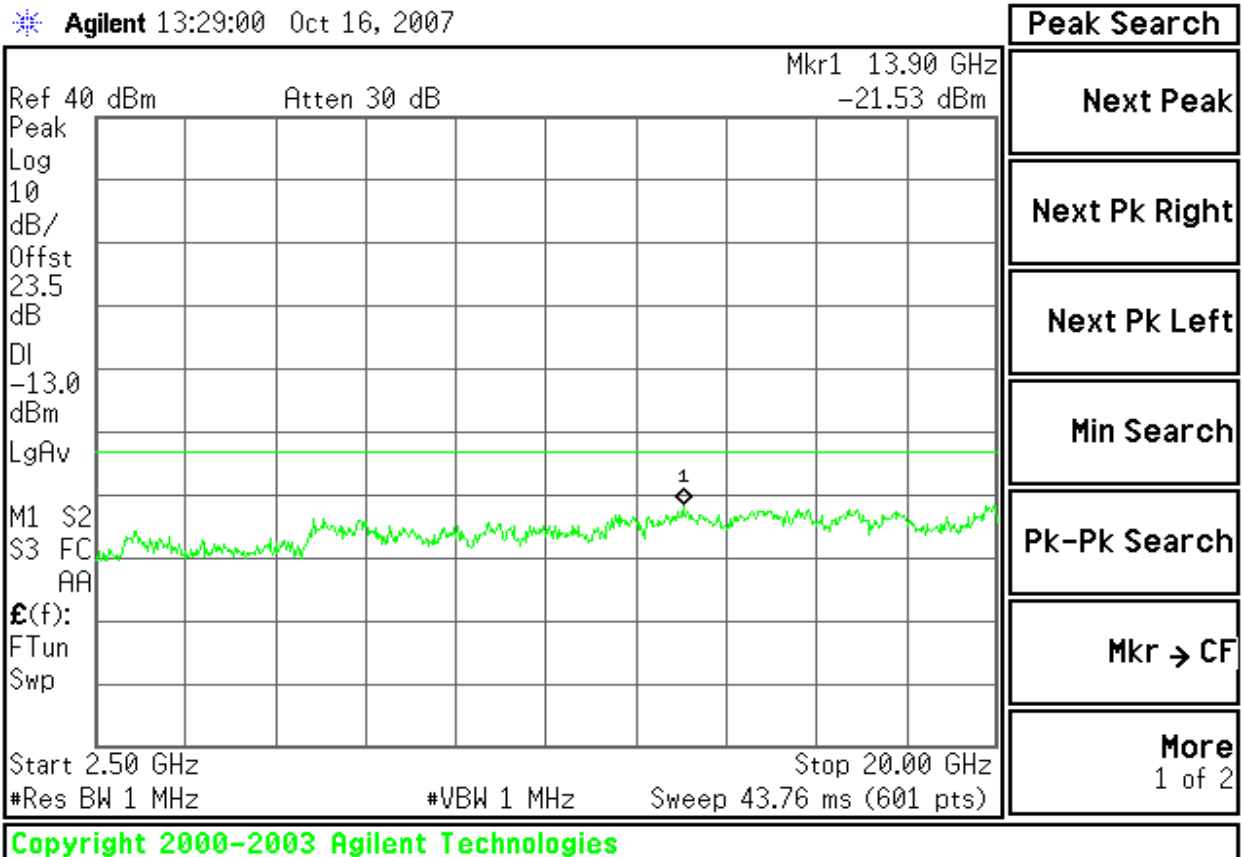

Figure 7-6: Out of Band emission at antenna terminals – GSM CH High





GSM 1900

Figure 8-1: Out of Band emission at antenna terminals – GSM CH Low

Agilent 13:24:32 Oct 16, 2007

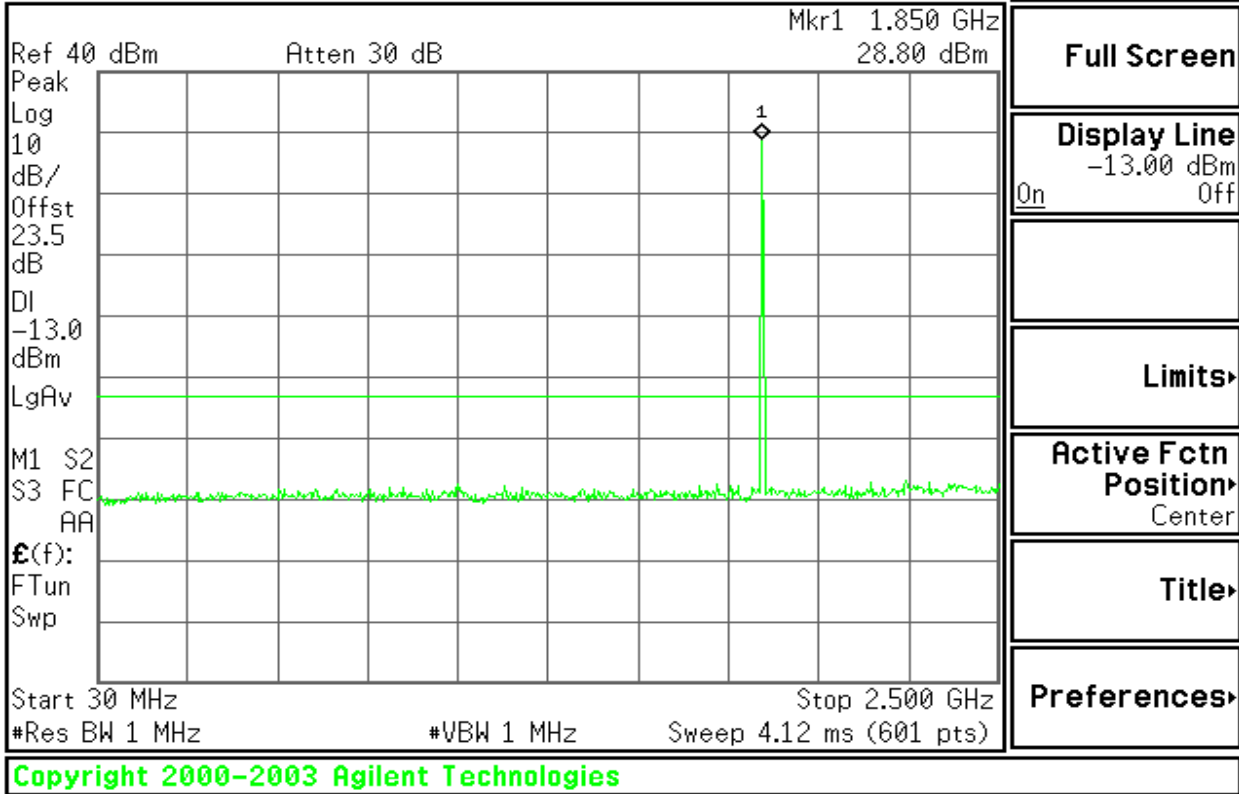

Figure 8-2: Out of Band emission at antenna terminals – GSM CH Low

Agilent 13:25:52 Oct 16, 2007

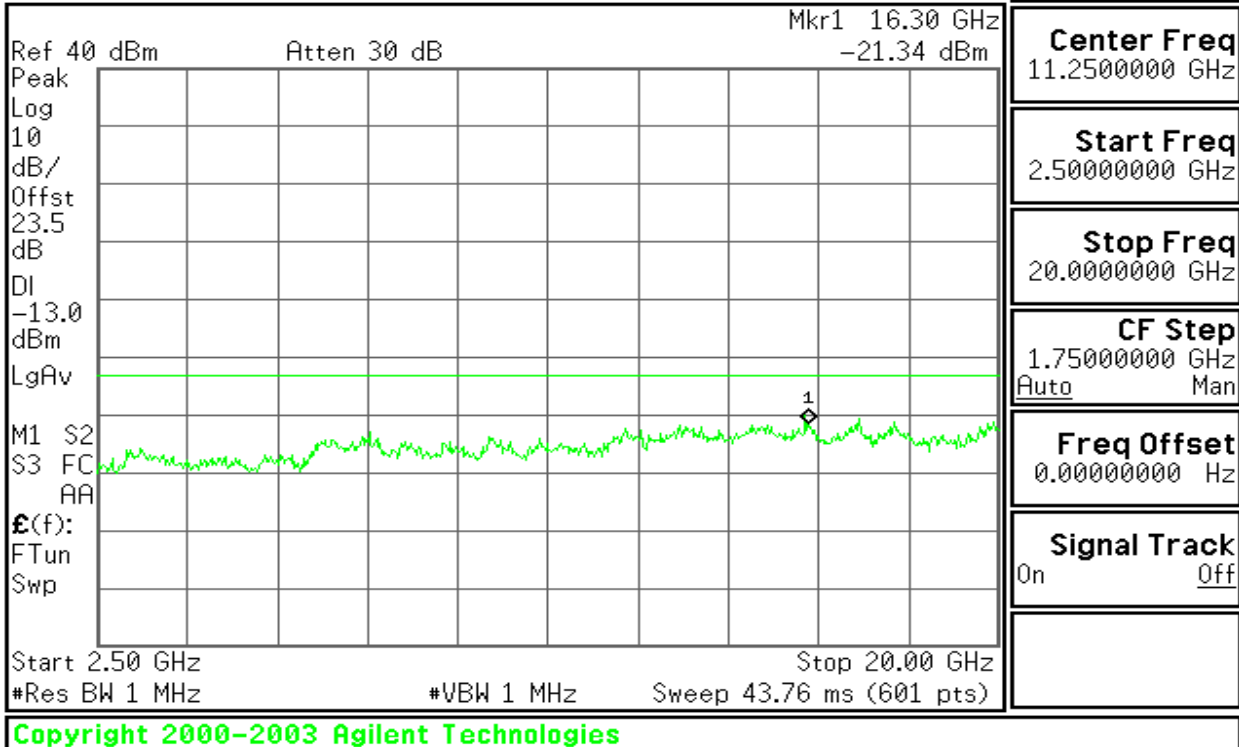

Figure 8-3: Out of Band emission at antenna terminals – GSM CH Mid

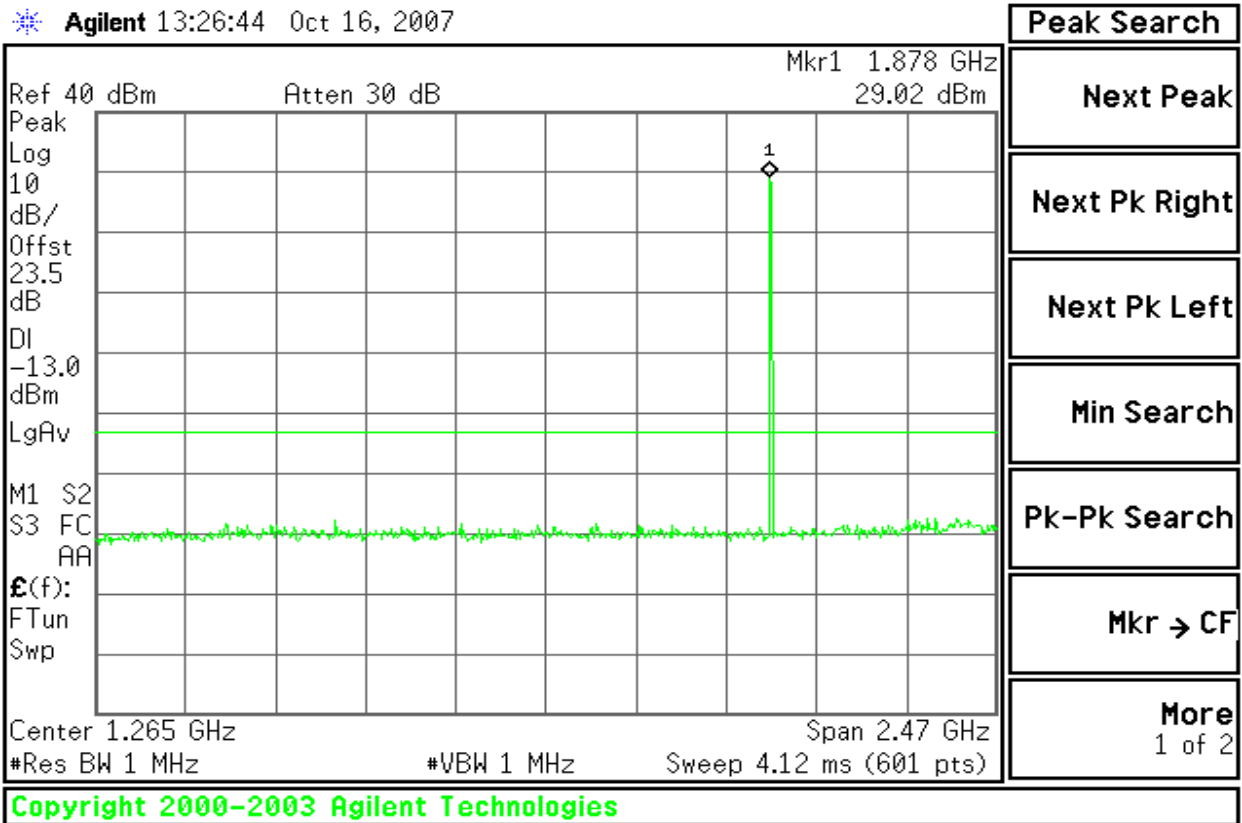

Figure 8-4: Out of Band emission at antenna terminals – GSM CH Mid

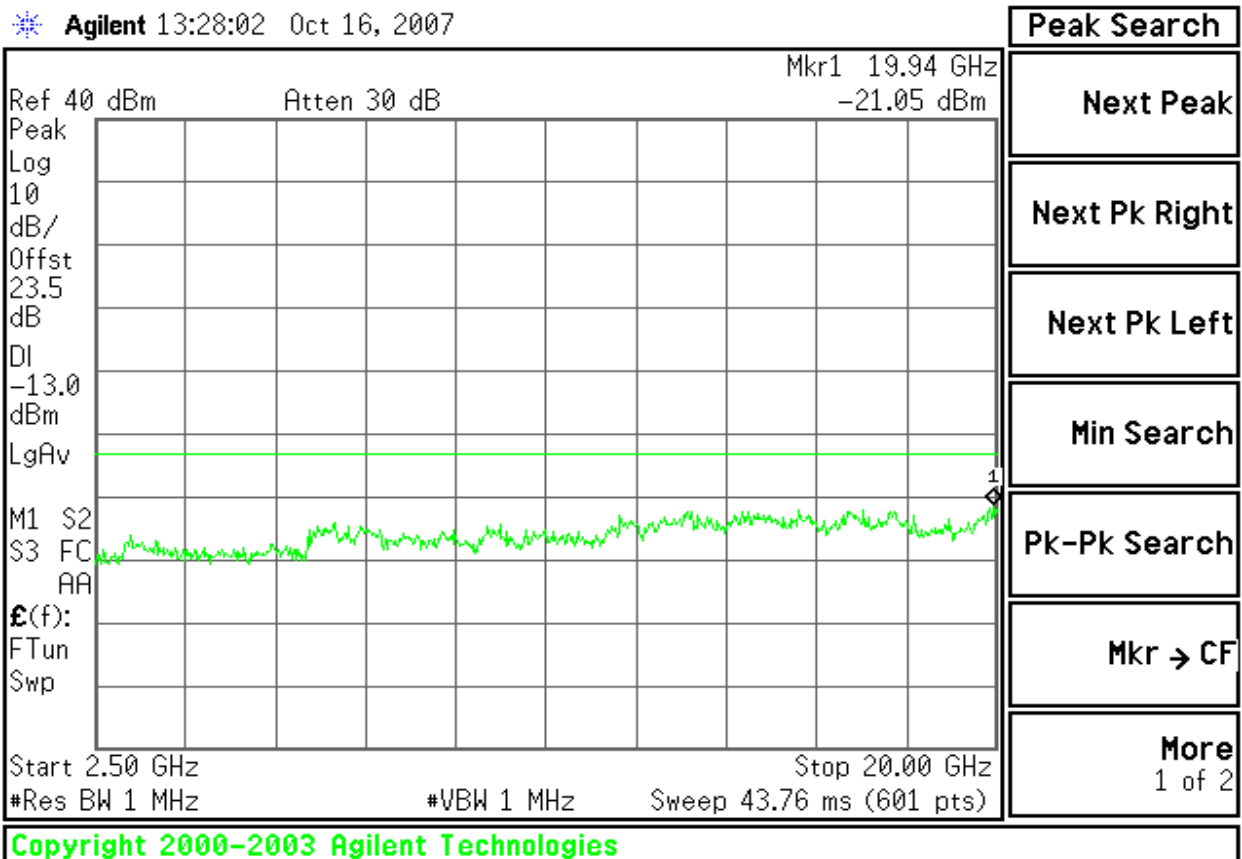

Figure 8-5: Out of Band emission at antenna terminals – GSM CH High

Agilent 13:27:24 Oct 16, 2007

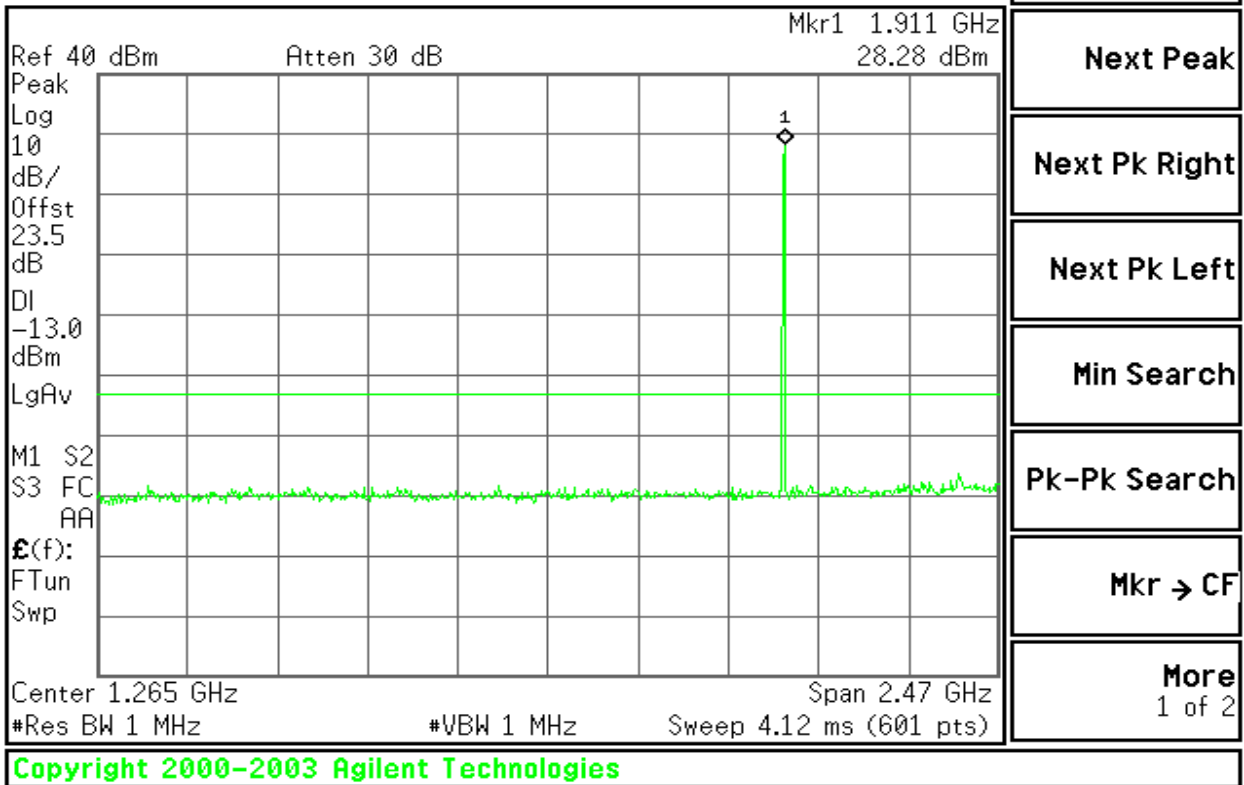
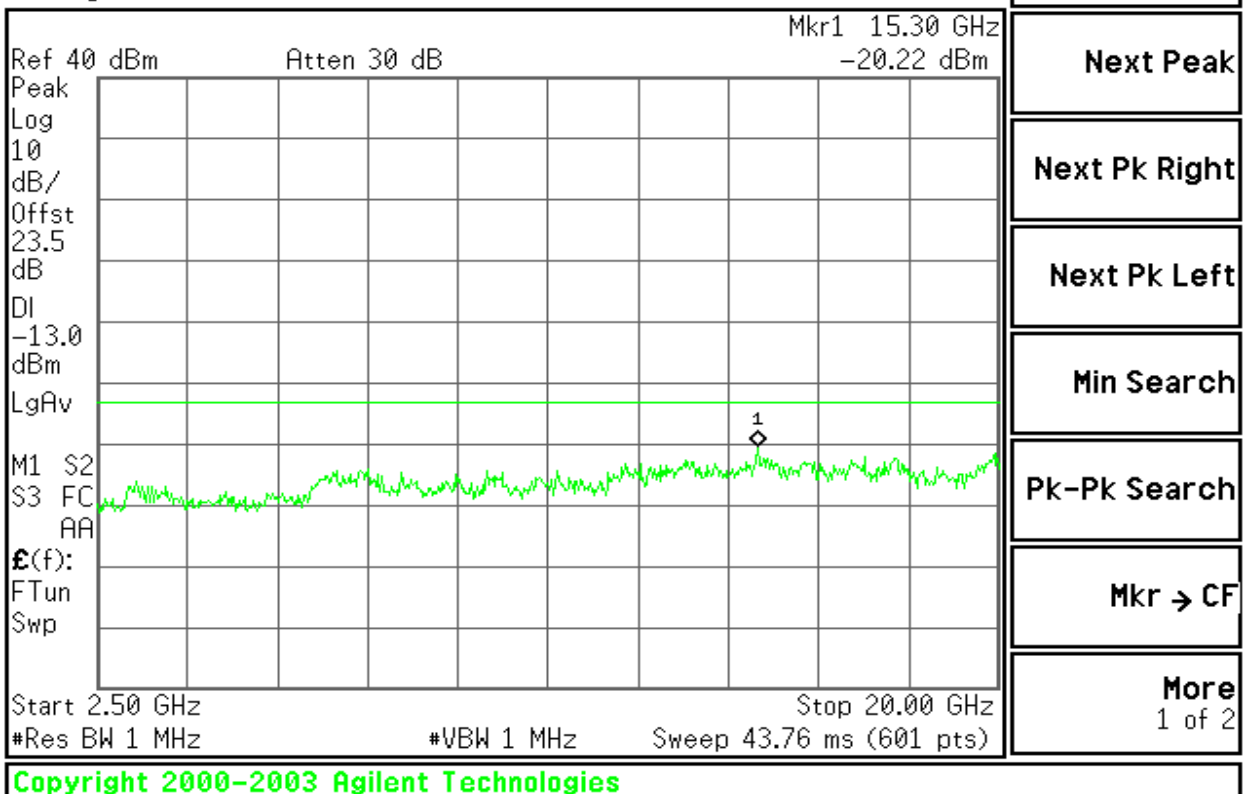

Figure 8-6: Out of Band emission at antenna terminals – GSM CH High

Agilent 13:26:05 Oct 16, 2007





GSM 850

Figure 9-1: Band Edge emissions – GSM CH Low

Agilent 14:04:00 Oct 16, 2007

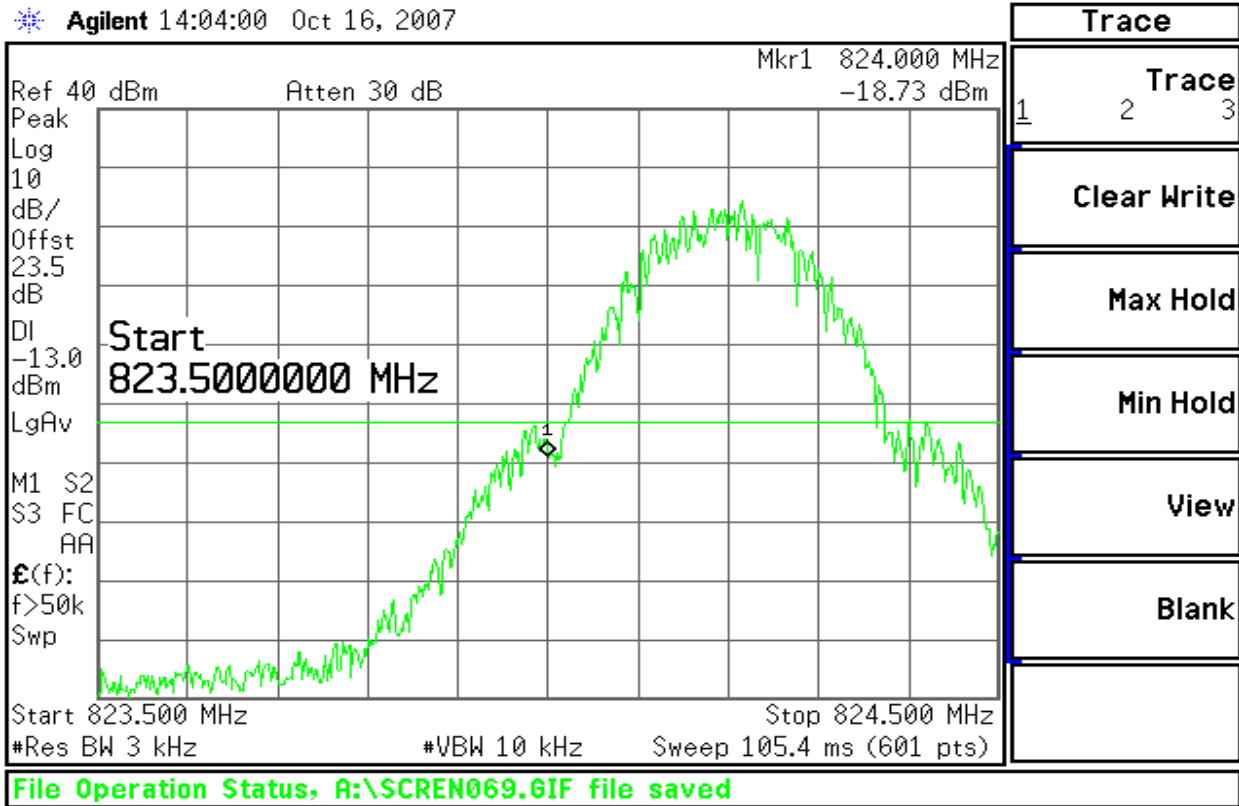
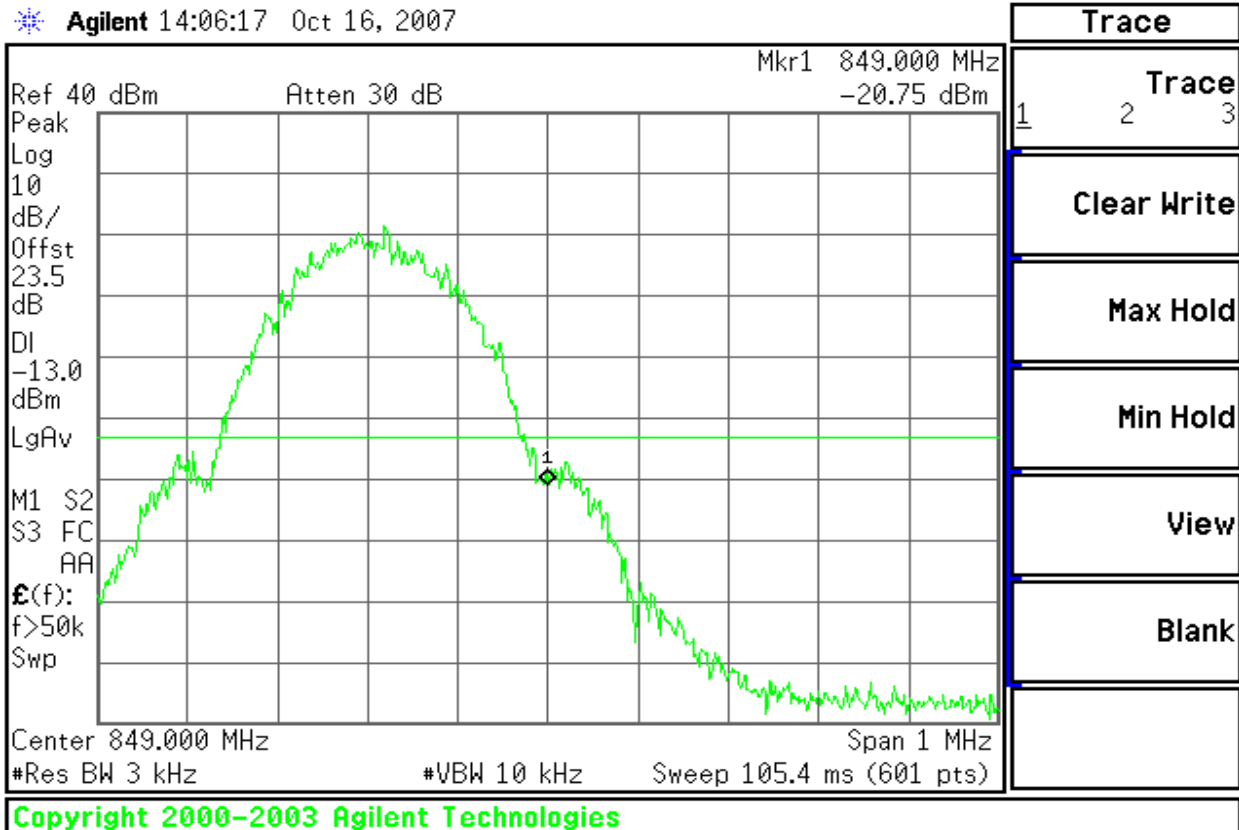

Figure 9-2: Band Edge emissions – GSM CH High

Agilent 14:06:17 Oct 16, 2007





GSM 1900

Figure 10-1: Band Edge emissions – GSM CH Low

Agilent 14:02:08 Oct 16, 2007

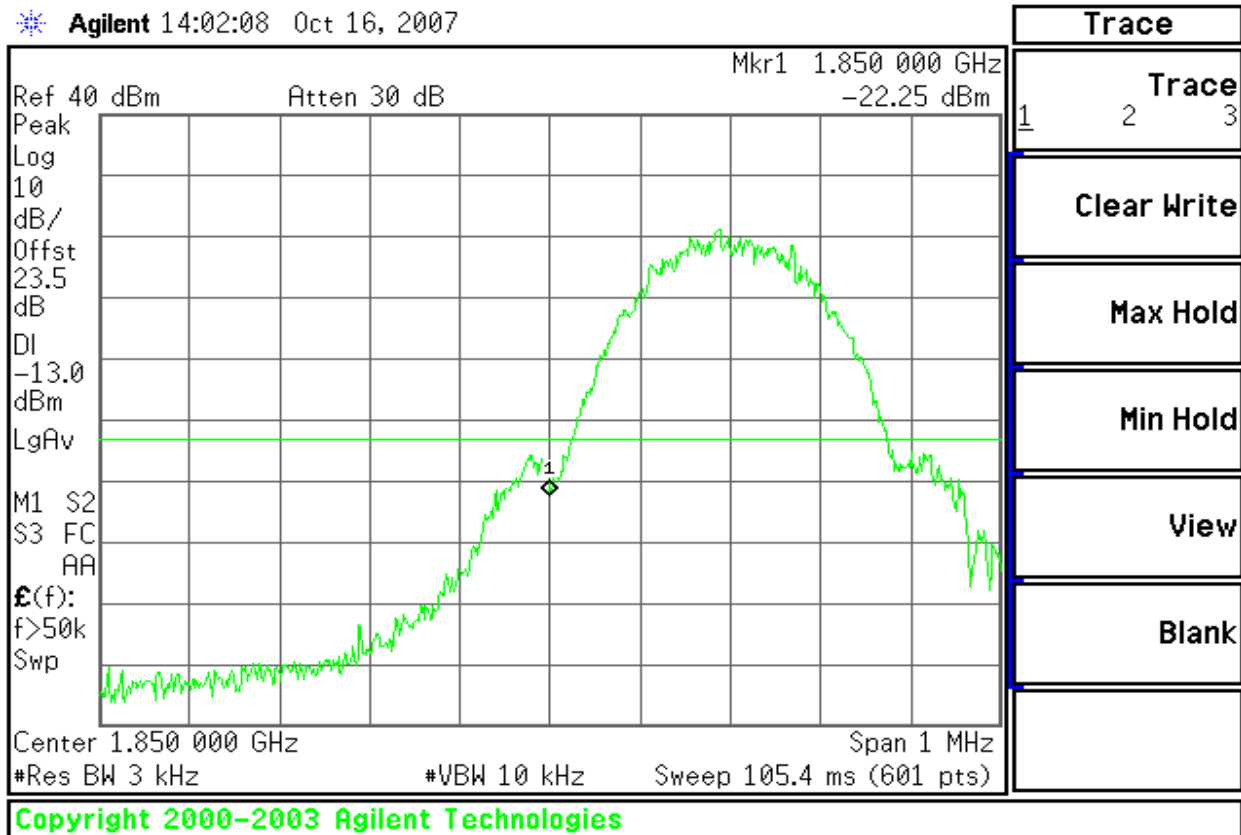
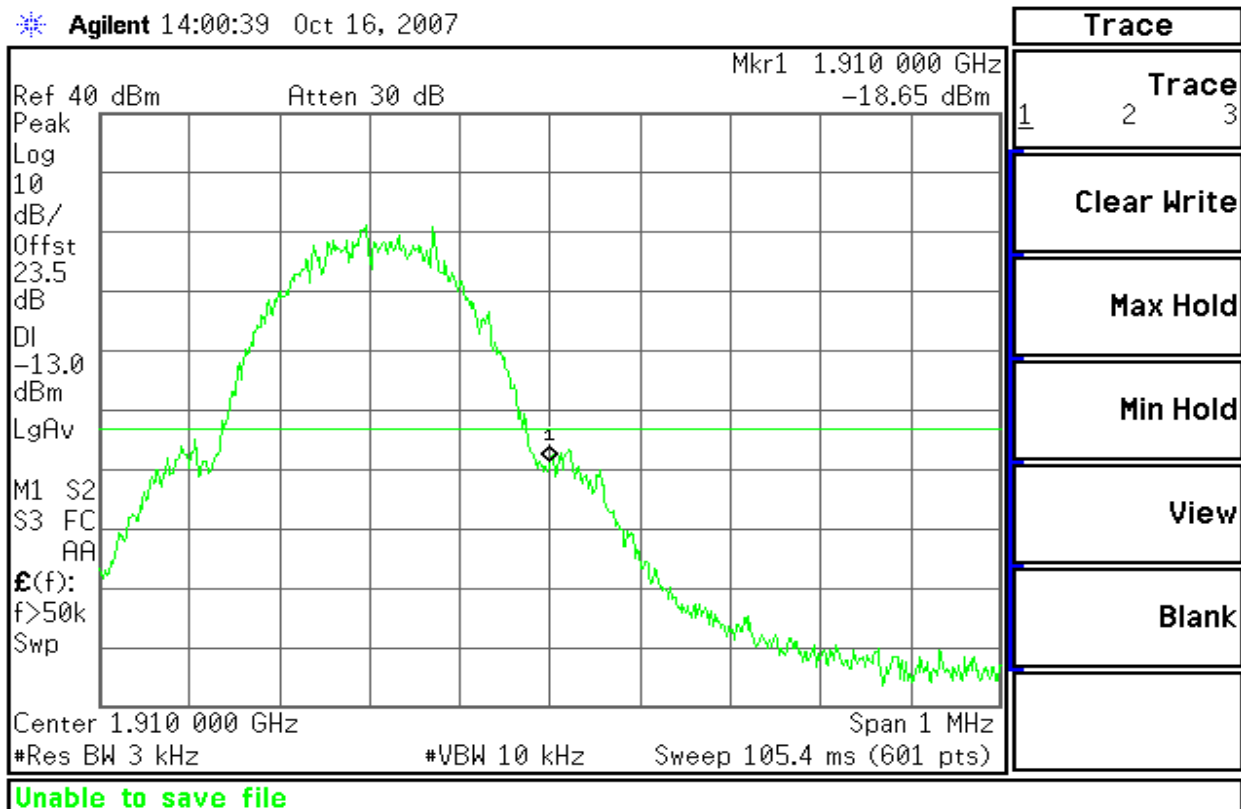

Figure 10-2: Band Edge emissions – GSM CH High

Agilent 14:00:39 Oct 16, 2007





FIELD STRENGTH OF SPURIOUS RADIATION MEASUREMENT

LIMIT

According to FCC §2.1053

MEASUREMENT EQUIPMENT USED

977 Chamber (3m)				
Name of Equipment	Manufacturer	Model	Serial Number	Calibration Due
Spectrum Analyzer	Agilent	E4446A	MY44020154	08/16/2008
EMI Test Receiver	R&S	ESPI3	101026	11/11/2007
Pre-Amplifier	MINI-circuits	ZFL-1000VH2	d041703	12/13/2007
Pre-Amplifier	Miteq	NSP4000-NF	870731	01/28/2008
Bilog Antenna	Sunol	JB1	A110204-2	11/22/2007
Horn-antenna	SCHWARZBECK	BBHA9120D	D:266	02/01/2008
PSG Analog Signal Generator	Agilent	E8257C	MY43321570	12/19/2007
Wireless communication test set	Agilent	8960	QB44051695	10/06/2008
Turn Table	CT	CT123	4165	N.C.R
Antenna Tower	CT	CTERG23	3256	N.C.R
Controller	CT	CT100	95637	N.C.R
Site NSA	CCS	N/A	N/A	04/06/2008

Remark: Each piece of equipment is scheduled for calibration once a year.

Test Configuration

Below 1 GHz

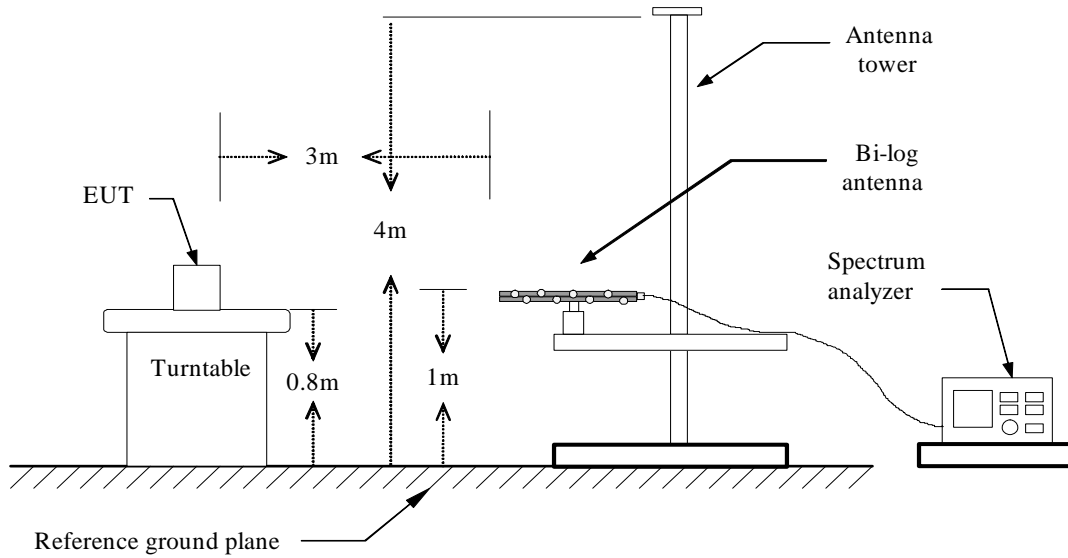

Above 1 GHz

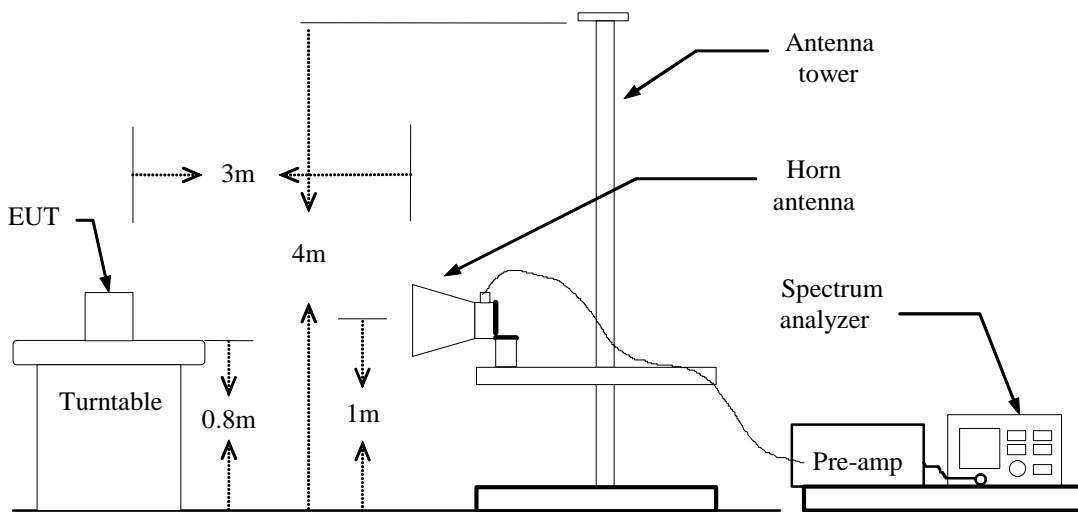

Substituted Method Test Set-up

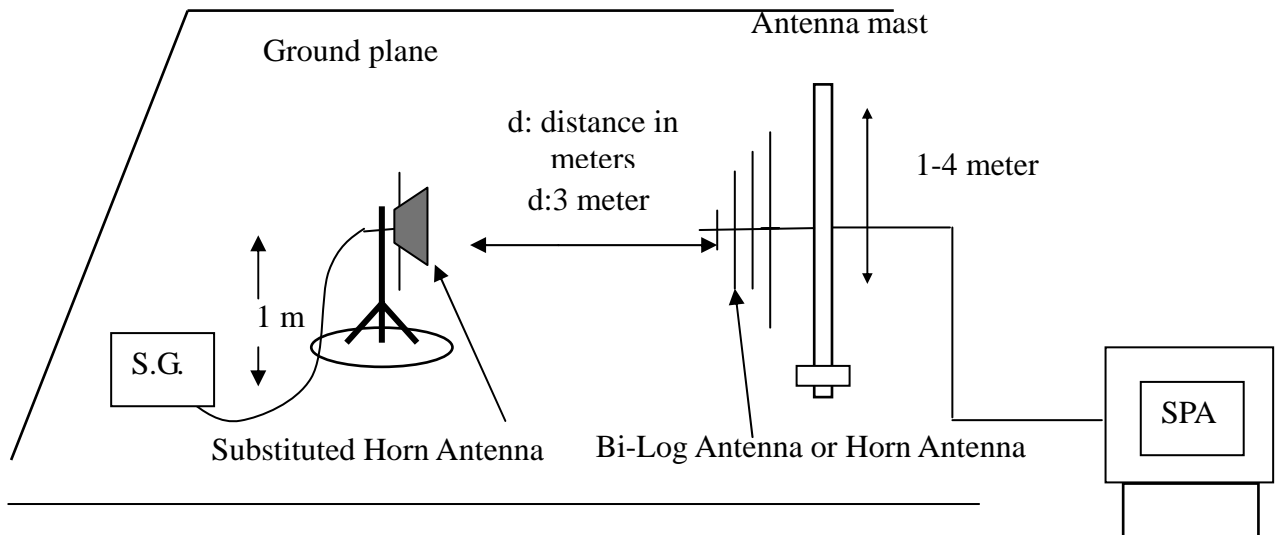



TEST PROCEDURE

The EUT was placed on a non-conductive, the measurement antenna was placed at a distance of 3 meters from the EUT. During the tests, the antenna height and the EUT azimuth were varied in order to identify the maximum level of emissions from the EUT. This maximization process was repeated with the EUT positioned in each of its three orthogonal orientations.

The frequency range up to tenth harmonic was investigated for each of three fundamental frequency (low, middle and high channels). Once spurious emission were identified, the power of the emission was determined using the substitution method.

The spurious emissions attenuation was calculated as the difference between radiated power at the fundamental frequency and the spurious emissions frequency.

ERP = S.G. output (dBm) + Antenna Gain (dBd) – Cable (dB)

EIRP = S.G. output (dBm) + Antenna Gain (dBi) – Cable (dB)

TEST RESULTS

Refer to the attached tabular data sheets.

**Radiated Spurious Emission Measurement Result****Below 1GHz**

No emissions to be recorded.

(Since no specific emission noted beyond the background noise floor)

Above 1GHz**Operation Mode:** GSM 850 / TX / CH 128**Test Date:** October 12,2007**Temperature:** 25°C**Tested by:** Jeff**Humidity:** 55 % RH**Polarity:** Ver. / Hor.

Frequency (MHz)	Reading level (dBuV)	Antenna Polarization	S.G. (dBm)	Cable loss (dB)	Ant.Gain (dBd)	Emission level (dBm)	Limit (dBm)	Margin (dB)
1645.84	32.39	V	-80.56	4.01	7.86	-76.71	-13.00	-63.71
1647.53	32.96	H	-82.63	4.01	7.86	-78.78	-13.00	-65.78

Operation Mode: GSM 850 / TX / CH 190**Test Date:** October 12,2007**Temperature:** 25°C**Tested by:** Jeff**Humidity:** 55 % RH**Polarity:** Ver. / Hor.

Frequency (MHz)	Reading level (dBuV)	Antenna Polarization	S.G. (dBm)	Cable loss (dB)	Ant.Gain (dBd)	Emission level (dBm)	Limit (dBm)	Margin (dB)
1675.84	35.54	V	-75.86	4.21	7.95	-72.12	-13.00	-59.12
1677.86	35.23	H	-78.98	4.21	7.95	-75.24	-13.00	-62.24

Operation Mode: GSM 850 / TX / CH 251**Test Date:** October 12,2007**Temperature:** 25°C**Tested by:** Jeff**Humidity:** 55 % RH**Polarity:** Ver. / Hor.

Frequency (MHz)	Reading level (dBuV)	Antenna Polarization	S.G. (dBm)	Cable loss (dB)	Ant.Gain (dBd)	Emission level (dBm)	Limit (dBm)	Margin (dB)
1698.45	36.68	V	-73.77	4.53	8.12	-70.18	-13.00	-57.18
1699.63	35.72	H	-74.89	4.53	8.12	-71.30	-13.00	-58.30

Remark:

- 1. Measuring frequencies from 1 GHz to the 10th harmonic of highest fundamental frequency.*
- 2. Measurements above shown only up to 6 maximum emissions noted, or would be lesser, with " N/A " remark, if no specific emissions from the EUT are recorded (ie: margin>20dB from the applicable limit) and considered that's already beyond the background noise floor.*



3. *Data of measurement within this frequency range shown “ --- ” in the table above means the reading of emissions are attenuated more than 20dB below the permissible limits or the field strength is too small to be measured.*
4. *Radiated emissions measured in frequency above 1000MHz were made with an instrument using Peak detector mode and average detector mode of the emission shown in Actual FS column.*
5. *Spectrum setting:*
 - a. *Peak Setting 1GHz to 10th harmonics of fundamental, RBW = 1MHz, VBW = 1MHz, Sweep time = Auto.*
 - b. *AV Setting 1GHz to 10th harmonics of fundamental, RBW = 1MHz, VBW = 10Hz, Sweep time = Auto.*



Below 1GHz

No emissions to be recorded.

(Since no specific emission noted beyond the background noise floor)

Above 1GHz

Operation Mode: GSM 1900 / TX / CH 512

Test Date: October 12, 2007

Temperature: 25°C

Tested by: Jeff

Humidity: 55 % RH

Polarity: Ver. / Hor.

Frequency (MHz)	Reading level (dBuV)	Antenna Polarization	S.G. (dBm)	Cable loss (dB)	Ant.Gain (dBi)	Emission level (dBm)	Limit (dBm)	Margin (dB)
3702.32	26.55	V	-73.64	6.65	13.40	-66.89	-13.00	-53.89
3704.24	25.82	H	-70.02	6.65	13.40	-63.27	-13.00	-50.27

Operation Mode: GSM 1900 / TX / CH 661

Test Date: October 12, 2007

Temperature: 25°C

Tested by: Jeff

Humidity: 55 % RH

Polarity: Ver. / Hor.

Frequency (MHz)	Reading level (dBuV)	Antenna Polarization	S.G. (dBm)	Cable loss (dB)	Ant.Gain (dBi)	Emission level (dBm)	Limit (dBm)	Margin (dB)
3761.32	27.51	V	-75.23	6.75	13.56	-68.42	-13.00	-55.42
3762.98	26.47	H	-75.19	6.75	13.56	-68.38	-13.00	-55.38

Operation Mode: GSM 1900 / TX / CH 810

Test Date: October 12, 2007

Temperature: 25°C

Tested by: Jeff

Humidity: 55 % RH

Polarity: Ver. / Hor.

Frequency (MHz)	Reading level (dBuV)	Antenna Polarization	S.G. (dBm)	Cable loss (dB)	Ant.Gain (dBi)	Emission level (dBm)	Limit (dBm)	Margin (dB)
3820.56	27.31	V	-73.54	6.84	14.25	-66.13	-13.00	-53.13
3821.20	26.53	H	-74.54	6.84	14.25	-67.13	-13.00	-54.13

Remark:

1. Measuring frequencies from 1 GHz to the 10th harmonic of highest fundamental frequency.
2. Measurements above shown only up to 6 maximum emissions noted, or would be lesser, with " N/A " remark, if no specific emissions from the EUT are recorded (ie: margin>20dB from the applicable limit) and considered that's already beyond the background noise floor.
3. Data of measurement within this frequency range shown " --- " in the table above means the reading of emissions are attenuated more than 20dB below the permissible



limits or the field strength is too small to be measured.

4. Radiated emissions measured in frequency above 1000MHz were made with an instrument using Peak detector mode and average detector mode of the emission shown in Actual FS column.

5. Spectrum setting:

a. Peak Setting 1GHz to 10th harmonics of fundamental, RBW = 1MHz, VBW = 1MHz, Sweep time = Auto.

b. AV Setting 1GHz to 10th harmonics of fundamental, RBW = 1MHz, VBW = 10Hz, Sweep time = Auto.

FREQUENCY STABILITY V.S. TEMPERATURE MEASUREMENT

LIMIT

According to FCC §2.1055, FCC §24.235.

Frequency Tolerance: 2.5 ppm

MEASUREMENT EQUIPMENT USED

Name of Equipment	Manufacturer	Model	Serial Number	Calibration Due
DC POWER SUPPLY	GW instek	GPS-3303C	E903131	04/15/2008
Spectrum Analyzer	Agilent	E4446A	MY44020154	08/16/2008
Wireless communication test set	Agilent	8960	QB44051695	10/06/2008
Temp. / Humidity Chamber	Kingson	THS-M1	242	05/26/2008

Remark: Each piece of equipment is scheduled for calibration once a year.

Test Configuration

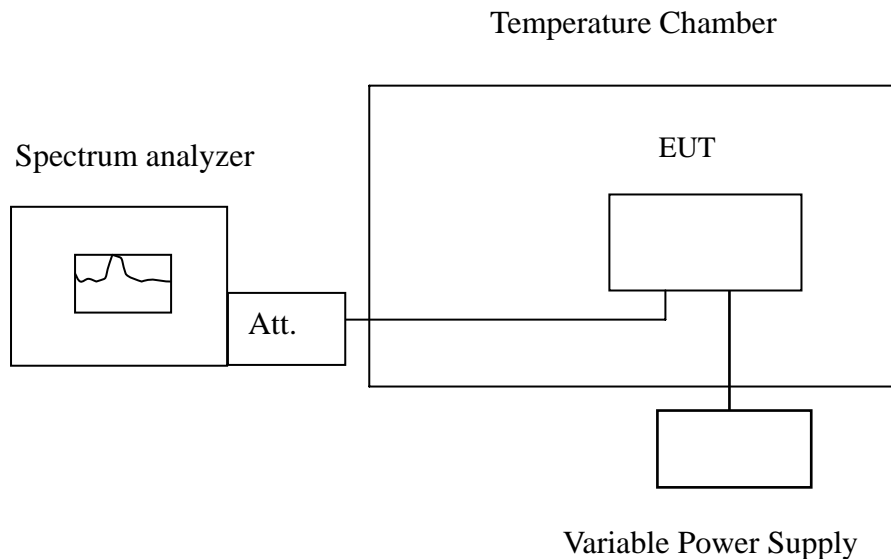

Remark: Measurement setup for testing on Antenna connector



TEST PROCEDURE

The equipment under test was connected to an external AC or DC power supply and input rated voltage. RF output was connected to a frequency counter or spectrum analyzer via feed through attenuators. The EUT was placed inside the temperature chamber. Set the spectrum analyzer RBW low enough to obtain the desired frequency resolution and measure EUT 20°C operating frequency as reference frequency. Turn EUT off and set the chamber temperature to -30°C. After the temperature stabilized for approximately 30 minutes recorded the frequency. Repeat step measure with 10°C increased per stage until the highest temperature of +50°C reached.

TEST RESULTS

No non-compliance noted.

Reference Frequency: GSM Mid Channel 836.6 MHz @ 20°C				
Limit: ± 2.5 ppm = 2091.5 Hz				
Power Supply Vdc	Environment Temperature (°C)	Frequency (Hz)	Delta (Hz)	Limit (Hz)
3.7	50	836600021	39.00	2091.5
	40	836600025	43.00	
	30	836600019	37.00	
	20	836599982	0.00	
	10	836600023	41.00	
	0	836600021	39.00	
	-10	836600030	48.00	
	-20	836600028	46.00	
	-30	836600032	50.00	

Reference Frequency: GSM Mid Channel 1880 MHz @ 20°C				
Limit: ± 2.5 ppm = 4700 Hz				
Power Supply Vdc	Environment Temperature (°C)	Frequency (Hz)	Delta (Hz)	Limit (Hz)
3.7	50	1879999975	-38.00	4700
	40	1879999977	-36.00	
	30	1879999973	-40.00	
	20	1880000013	0.00	
	10	1879999986	-27.00	
	0	1879999974	-39.00	
	-10	1879999978	-35.00	
	-20	1879999980	-33.00	
	-30	1879999978	-35.00	

FREQUENCY STABILITY V.S. VOLTAGE MEASUREMENT

LIMIT

According to FCC §2.1055, FCC §24.235,

Frequency Tolerance: 2.5 ppm.

MEASUREMENT EQUIPMENT USED

Name of Equipment	Manufacturer	Model	Serial Number	Calibration Due
DC POWER SUPPLY	GW instek	GPS-3303C	E903131	04/15/2008
Spectrum Analyzer	Agilent	E4446A	MY44020154	08/16/2008
Wireless communication test set	Agilent	8960	QB44051695	10/06/2008
Temp. / Humidity Chamber	Kingson	THS-M1	242	05/26/2008

Remark: Each piece of equipment is scheduled for calibration once a year.

Test Configuration

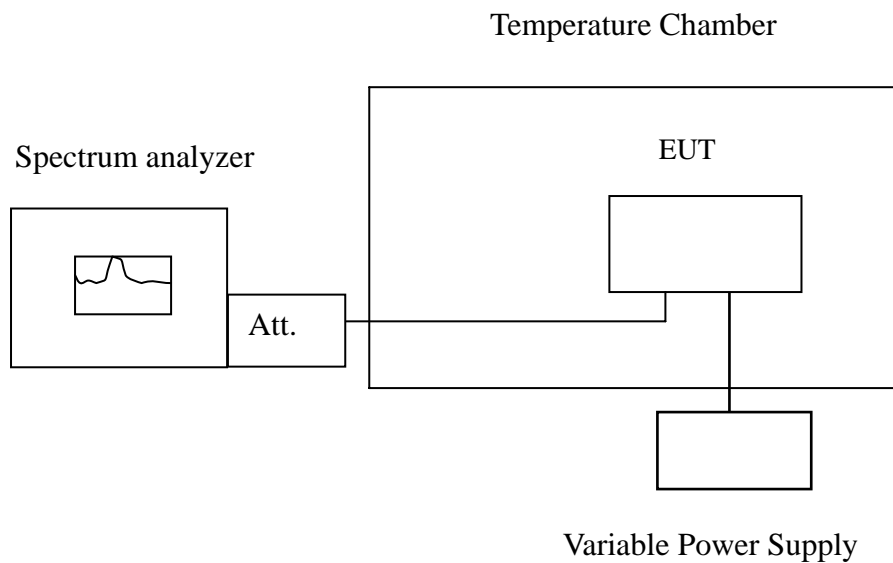

Remark: Measurement setup for testing on Antenna connector.



TEST PROCEDURE

Set chamber temperature to 20°C. Use a variable AC power supply / DC power source to power the EUT and set the voltage to rated voltage. Set the spectrum analyzer RBW low enough to obtain the desired frequency resolution and recorded the frequency.

Reduce the input voltage to specify extreme voltage variation ($\pm 15\%$) and endpoint, record the maximum frequency change.

TEST RESULTS

No non-compliance noted.

Reference Frequency: GSM Mid Channel 836.6 MHz @ 20°C				
Limit: ± 2.5 ppm = 2091.5Hz				
Power Supply Vdc	Environment Temperature (°C)	Frequency (Hz)	Delta (Hz)	Limit (Hz)
4.3	20	836599978	-3	2091.5
3.7		836599981	0	
3.2 (End Point)		836599974	-7	

Reference Frequency: GSM Mid Channel 1880 MHz @ 20°C				
Limit: ± 2.5 ppm = 4700 Hz				
Power Supply Vdc	Environment Temperature (°C)	Frequency (Hz)	Delta (Hz)	Limit (Hz)
4.3	20	1880000028	7	4700
3.7		1880000021	0	
3.2 (End Point)		1880000022	1	



POWERLINE CONDUCTED EMISSIONS

LIMIT

For an intentional radiator which is designed to be connected to the public utility (AC) power line, the radio frequency voltage that is conducted back onto the AC power line on any frequency or frequencies within the band 150 kHz to 30 MHz shall not exceed 250 microvolts (The limit decreases linearly with the logarithm of the frequency in the range 0.15 MHz to 0.50 MHz). The limits at specific frequency range is listed as follows:

Frequency Range (MHz)	Limits (dBμV)	
	Quasi-peak	Average
0.15 to 0.50	66 to 56	56 to 46
0.50 to 5	56	46
5 to 30	60	50

Compliance with this provision shall be based on the measurement of the radio frequency voltage between each power line (LINE and NEUTRAL) and ground at the power terminals.

MEASUREMENT EQUIPMENT USED

Name of Equipment	Manufacturer	Model	Serial Number	Calibration Due
EMI Test Receiver	R&S	ESI26	100068	02/11/2008
EMC Analyzer	Agilent	E7402A	US41160329	02/11/2008
LISN	FCC	FCC-LISN-50-50-2-M	01067	07/29/2008
LISN (EUT)	FCC	FCC-LISN-50-50-2-M	01068	07/29/2008
TRANSIENT LIMITER	SCHAFFNER	CFL9206	1710	03/15/2008
EMI Monitor control box	FCC	0-SVDC	N/A	N.C.R

Remark: Each piece of equipment is scheduled for calibration once a year.

Test Configuration

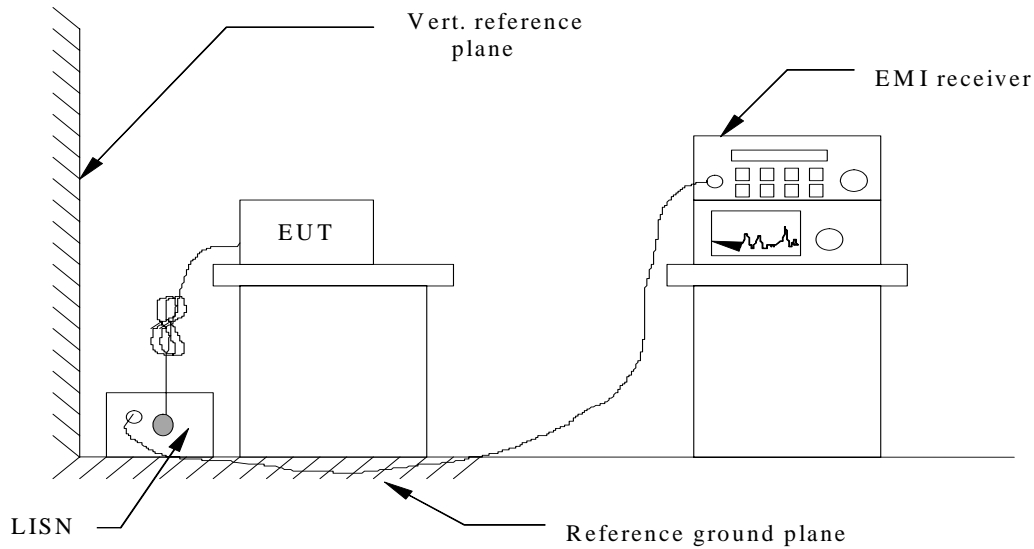

See test photographs attached in Appendix 1 for the actual connections between EUT and support equipment.

TEST PROCEDURE

1. The EUT was placed on a table, which is 0.8m above ground plane.
2. Maximum procedure was performed on the six highest emissions to ensure EUT compliance.
3. Repeat above procedures until all frequency measured were complete..

DECISION OF FINAL TEST MODE

The following test mode(s) were scanned during the final test:

AC to DC charger

Trade Name : SAGEM

Model Number :My203L



TEST RESULTS

The initial step in collecting conducted data is a spectrum analyzer peak scan of the measurement range. Significant peaks are then marked as shown on the following data page, and these signals are then quasi-peaked.

Operation Mode: Link mode
AC TO DC CHARGER **Test Date:** October 12, 2007

Temperature: 25°C **Tested by:** Jeff

Humidity: 55% RH

Freq. (MHz)	PEAK. Raw (dBuV)	Q.P. Raw (dBuV)	AVG Raw (dBuV)	Q.P. Limit (dBuV)	AVG Limit (dBuV)	Margin (dB)	Factor (dB)	Remark
0.420	47.75	29.20	27.31	58.29	48.29	-20.98	10.18	L1
0.555	45.65	19.56	18.42	56.00	46.00	-27.58	10.11	L1
0.655	44.38	17.68	16.42	56.00	46.00	-29.58	10.12	L1
0.770	41.43	23.84	22.25	56.00	46.00	-23.75	10.13	L1
1.390	39.22	19.98	18.45	56.00	46.00	-27.55	10.27	L1
2.085	38.27	17.65	16.52	56.00	46.00	-29.48	10.42	L1
0.175	49.28	31.41	31.30	65.29	55.29	-23.99	11.25	L2
0.425	43.34	20.36	19.26	58.14	48.14	-28.88	10.24	L2
0.525	43.68	18.18	18.43	56.00	46.00	-27.57	10.24	L2
0.600	41.20	19.54	19.32	56.00	46.00	-26.68	10.23	L2
2.085	36.42	15.26	14.65	56.00	46.00	-31.35	10.44	L2
2.750	36.04	16.38	15.94	56.00	46.00	-30.06	10.54	L2

Remark:

1. The measuring frequencies range between 0.15 MHz and 30 MHz.
2. The emissions measured in the frequency range between 0.15 MHz and 30MHz were made with an instrument using Quasi-peak detector and Average detector.
3. "---" denotes the emission level was or more than 2dB below the Average limit, and no re-check was made.
4. The IF bandwidth of SPA between 0.15MHz and 30MHz was 10KHz. The IF bandwidth of Test Receiver between 0.15MHz and 30MHz was 9kHz
5. L1 = Line One (Live Line) / L2 = Line Two (Neutral Line)

Note:

Freq. = Emission frequency in KHz

Factor (dB) = cable loss + Insertion loss of LISN+ Insertion loss of TRANSIENT LIMITER (The



TRANSIENT LIMITER included 10 dB ATTENUATION)

Amptd dBuV = Uncorrected Analyzer/Receiver reading + cable loss + Insertion loss of LISN+ Insertion loss of TRANSIENT LIMITER, if it > 0.5 dB

Limit dBuV = Limit stated in standard

Margin dB = Reading in reference to limit

Calculation Formula

Margin (dB) = Amptd (dBuV) - Limit (dBuV)

Test Plots

AC TO DC CHARGER

Conducted emissions (Line 1)

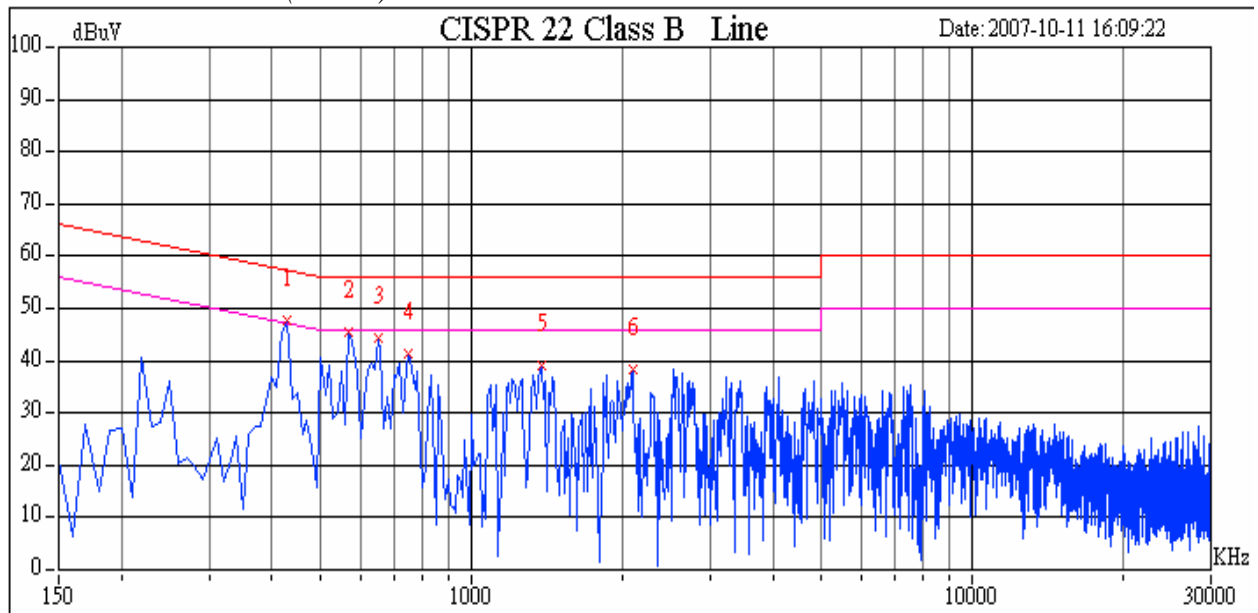

Conducted emissions (Line 2)

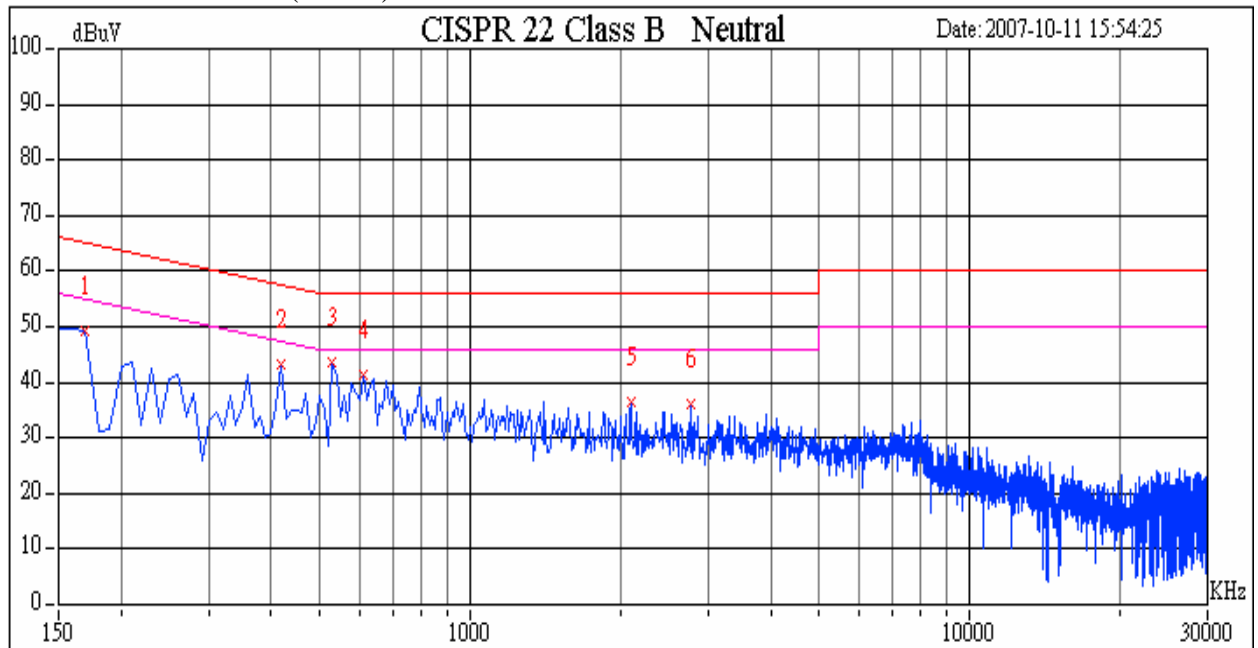

APPENDIX 1 PHOTOGRAPHS OF TEST SETUP

Radiated Emission Set up Photos

Front of view

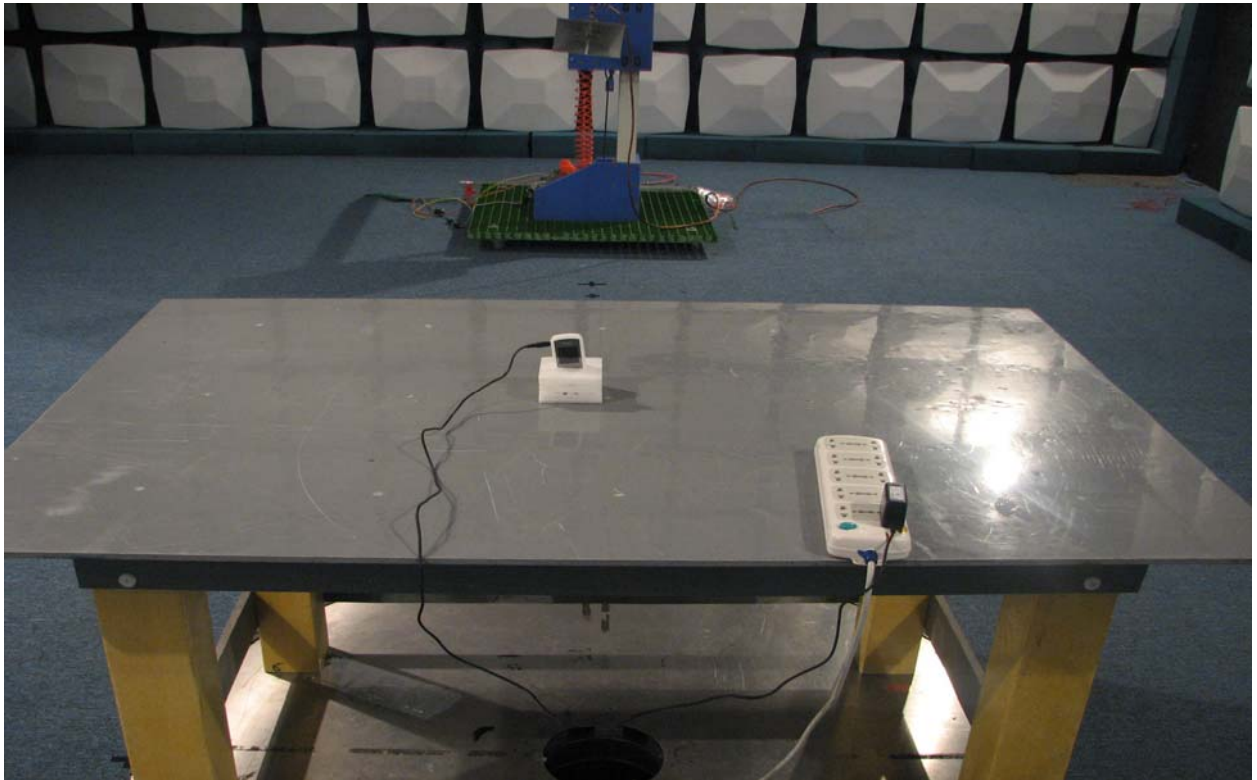

Back of view

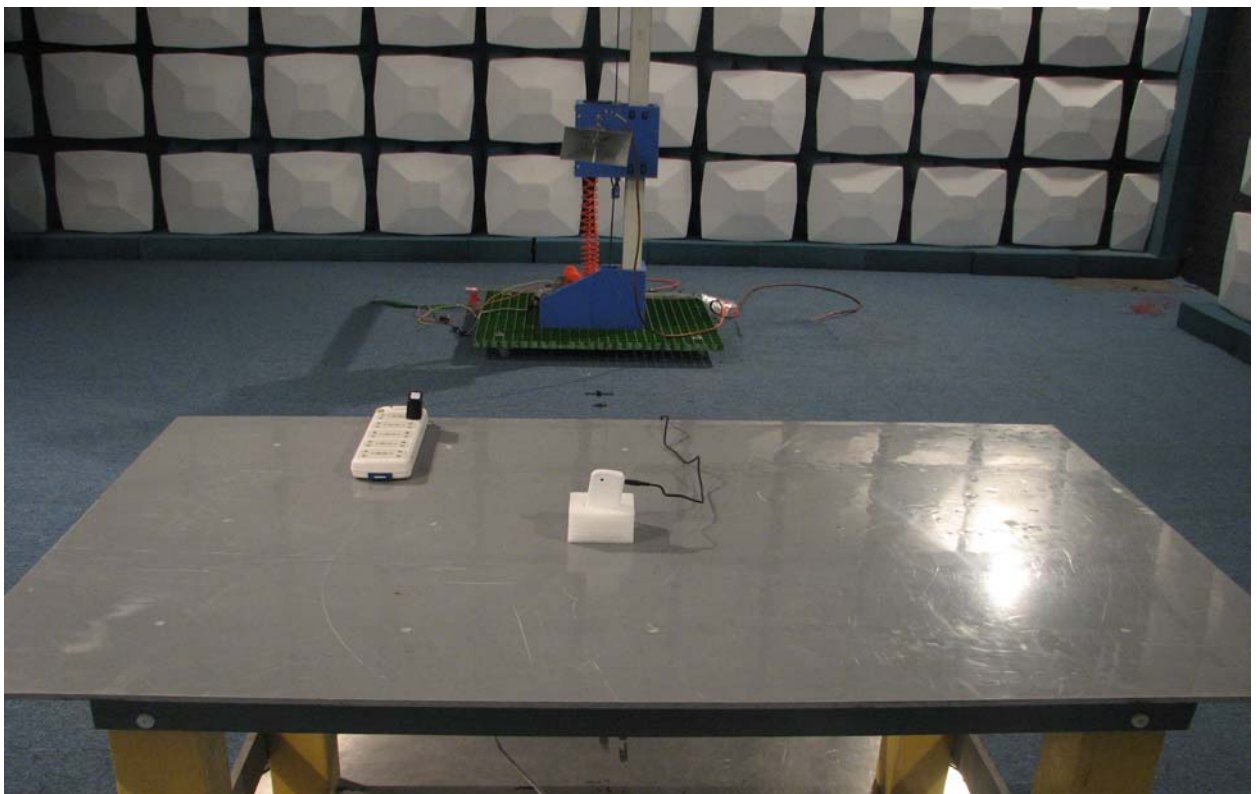

Conducted Emission SetUp Photos AC TO DC CHARGER

