



FCC TEST REPORT

REPORT NO.: RF990121L17B
MODEL NO.: FreeStyl 1
FCC ID: U2M-FS1
RECEIVED: Oct. 29, 2012
TESTED: Nov. 02 ~ Nov. 22, 2012
ISSUED: Nov. 27, 2012

APPLICANT: Senao Networks, Inc.

ADDRESS: 3F, No. 529, Chung Cheng Rd., Hsintien,
Taipei, Taiwan, R.O.C.

ISSUED BY: Bureau Veritas Consumer Products Services
(H.K.) Ltd., Taoyuan Branch

LAB ADDRESS: No. 47, 14th Ling, Chia Pau Vil., Lin Kou Dist.,
New Taipei City, Taiwan, R.O.C.

TEST LOCATION: No. 19, Hwa Ya 2nd Rd, Wen Hwa Tsuen,
Kwei Shan Hsiang, Taoyuan Hsien 333,
Taiwan, R.O.C.

This report should not be used by the client to claim product certification, approval, or endorsement by TAF or any government agencies.



This report is for your exclusive use. Any copying or replication of this report to or for any other person or entity, or use of our name or trademark, is permitted only with our prior written permission. This report sets forth our findings solely with respect to the test samples identified herein. The results set forth in this report are not indicative or representative of the quality or characteristics of the lot from which a test sample was taken or any similar or identical product unless specifically and expressly noted. Our report includes all of the tests requested by you and the results thereof based upon the information that you provided to us. You have 60 days from date of issuance of this report to notify us of any material error or omission caused by our negligence, provided, however, that such notice shall be in writing and shall specifically address the issue you wish to raise. A failure to raise such issue within the prescribed time shall constitute your unqualified acceptance of the completeness of this report, the tests conducted and the correctness of the report contents. Unless specific mention, the uncertainty of measurement has been explicitly taken into account to declare the compliance or non-compliance to the specification.



Table of Contents

1.	CERTIFICATION.....	3
2.	SUMMARY OF TEST RESULTS	4
2.1	MEASUREMENT UNCERTAINTY	4
3.	GENERAL INFORMATION.....	5
3.1	GENERAL DESCRIPTION OF EUT	5
3.2	DESCRIPTION OF TEST MODES.....	7
3.2.1	CONFIGURATION OF SYSTEM UNDER TEST	9
3.2.2	TEST MODE APPLICABILITY AND TESTED CHANNEL DETAIL.....	10
3.3	GENERAL DESCRIPTION OF APPLIED STANDARDS	11
3.4	DESCRIPTION OF SUPPORT UNITS	11
4.	TEST TYPES AND RESULTS	12
4.1	RADIATED EMISSION MEASUREMENT	12
4.1.1	LIMITS OF RADIATED EMISSION MEASUREMENT.....	12
4.1.2	TEST INSTRUMENTS	13
4.1.3	TEST PROCEDURES	14
4.1.4	DEVIATION FROM TEST STANDARD	14
4.1.5	TEST SETUP	15
4.1.6	EUT OPERATING CONDITIONS	15
4.1.7	TEST RESULTS	16
4.2	CONDUCTED EMISSION MEASUREMENT	25
4.2.1	LIMITS OF CONDUCTED EMISSION MEASUREMENT.....	25
4.2.2	TEST INSTRUMENTS	25
4.2.3	TEST PROCEDURES	26
4.2.4	DEVIATION FROM TEST STANDARD	26
4.2.5	TEST SETUP	27
4.2.6	EUT OPERATING CONDITIONS	27
4.2.7	TEST RESULTS	28
5.	PHOTOGRAPHS OF THE TEST CONFIGURATION.....	46
6.	INFORMATION ON THE TESTING LABORATORIES	47
7.	APPENDIX A - MODIFICATIONS RECORDERS FOR ENGINEERING CHANGES TO THE EUT BY THE LAB.....	48



A D T

1. CERTIFICATION

PRODUCT: Single Line Long Range Cordless Telephone

BRAND: EnGenius

MODEL: FreeStyl 1

APPLICANT: Senao Networks, Inc.

TESTED: Nov. 02 ~ Nov. 22, 2012

TEST SAMPLE: ENGINEERING SAMPLE

STANDARDS: **FCC Part 15, Subpart C (Section 15.247)**
ANSI C63.10-2009

This report is issued as a supplementary report of RF990121L17. This report shall be used combined together with its original report.

PREPARED BY :  , DATE : Nov. 27, 2012
Pettie Chen / Senior Specialist

APPROVED BY :  , DATE : Nov. 27, 2012
Ken Liu / Manager

NOTE: The radiated emission below 1GHz and conducted emission tests were performed for the addendum. Refer to original report for the other test data.



2. SUMMARY OF TEST RESULTS

The EUT has been tested according to the following specifications:

APPLIED STANDARD: FCC PART 15, SUBPART C (SECTION 15.247)			
STANDARD SECTION	TEST TYPE AND LIMIT	RESULT	REMARK
15.207	AC Power Conducted Emission	PASS	Meet the requirement of limit. Minimum passing margin is -1.41dB at 0.52109MHz.
15.247(a)(1)(i)	Number of Hopping Frequency Used	NA	Refer to Note
15.247(a)(1)(i)	Dwell Time on Each Channel	NA	Refer to Note
15.247(a)(1)(i)	1. Hopping Channel Separation 2. Spectrum Bandwidth of a Frequency Hopping Sequence Spread Spectrum System	NA	Refer to Note
15.247(b)	Maximum Peak Output Power	NA	Refer to Note
15.247(d)	Transmitter Radiated Emissions	PASS	Meet the requirement of limit. Minimum passing margin is -3.5dB at 738.10MHz
15.247(d)	Band Edge Measurement	NA	Refer to Note
15.203	Antenna Requirement	NA	Refer to Note

NOTE: The radiated emission below 1GHz and conducted emission tests were performed for the addendum. Refer to original report for the other test data.

2.1 MEASUREMENT UNCERTAINTY

Where relevant, the following measurement uncertainty levels have been estimated for tests performed on the EUT as specified in CISPR 16-4-2:

MEASUREMENT	FREQUENCY	UNCERTAINTY
Conducted Emission	9KHz~30MHz	2.44 dB
Radiated emissions	30MHz ~ 200MHz	2.93 dB
	200MHz ~1000MHz	2.95 dB

This uncertainty represents an expanded uncertainty expressed at approximately the 95% confidence level using a coverage factor of k=2.



3. GENERAL INFORMATION

3.1 GENERAL DESCRIPTION OF EUT

EUT	Single Line Long Range Cordless Telephone
MODEL NO.	FreeStyl 1
POWER SUPPLY	12Vdc (from AC Adapter) 3.7Vdc (from battery) 5.5Vdc (from charger)
MODULATION TYPE	MSK / TDD (Frequency hopping)
OPERATING FREQUENCY	902.269668 ~ 927.654755MHz
NUMBER OF CHANNEL	252
CHANNEL SPACING	101.136kHz
OUTPUT POWER	831.8mW
ANTENNA TYPE	Dipole antenna with 2dBi gain (Base Station) Dipole antenna with 2.5dBi gain (long Ant. Portable Handset) Dipole antenna with 1.5dBi gain (short Ant. Portable Handset)
ANTENNA CONNECTOR	Reversed-thread TNC (Base Station) Sheet metal (Portable Handset)
DATA CABLE	NA
I/O PORTS	Refer to user's manual
ACCESSORY DEVICE	Adapter, charger, Battery

NOTE:

1. This report is issued as a supplementary report of BVADT report no.: RF990121L17. This report shall be combined together with its original report.
2. This report is prepared for FCC class II permissive change. Difference compared with the original report is adding second source adapters. Therefore, we re-tested radiated emission below 1GHz and conducted emission tests and presented in the test report.
3. The EUT uses following adapters, battery & Charger.

ADAPTER 1 (for Base Station used)	
BRAND	Powertron Electronics Corp.
MODEL	PA1024-2DUA
INPUT POWER	100-240Vac, 50/60Hz, 0.6A
OUTPUT POWER	12Vdc, 1A, 12W Max
POEWR LINE	1.5m non-shielded cable without core

ADAPTER 2 (for Base Station used)	
BRAND	DVE
MODEL	DSA-15P-12 US 120120
INPUT POWER	100-240Vac, 50-60Hz, 0.5A
OUTPUT POWER	12Vdc, 1A, 12W Max
POEWR LINE	1.5m non-shielded cable without core



A D T

BATTERY (for Portable Handset used)	
BRAND	EnGenius
RATING	3.7Vdc, 1100mAh

ADAPTER 3 (for Portable Handset Charger used)	
BRAND	Powertron Electronics Corp.
MODEL	PA1008-1HU
INPUT POWER	100-240Vac, 50-60Hz, 0.3A
OUTPUT POWER	5.5Vdc, 1.45A, 8W Max
POEWR LINE	1.5m non-shielded cable without core

4. A set of the EUT include Base station & Portable handset
5. The above EUT information was declared by the manufacturer and for more detailed features description, please refer to the manufacturer's specifications or User's Manual.



A D T

3.2 DESCRIPTION OF TEST MODES

252 channels are provided to this EUT:

CH.	FREQ. (MHz)	CH.	FREQ. (MHz)	CH.	FREQ. (MHz)	CH	FREQ. (MHz)	CH	FREQ. (MHz)
1	902.269668	31	905.303742	61	908.337817	91	911.371891	121	914.405965
2	902.370804	32	905.404878	62	908.438952	92	911.473026	122	914.507100
3	902.471940	33	905.506014	63	908.540088	93	911.574162	123	914.608236
4	902.573076	34	905.607150	64	908.540088	94	911.675298	124	914.709372
5	902.674212	35	905.708286	65	908.742360	95	911.776434	125	914.810508
6	902.775347	36	905.809421	66	908.843496	96	911.877570	126	914.911644
7	902.876483	37	905.910557	67	908.944631	97	911.978705	127	915.012779
8	902.977619	38	906.011693	68	909.045767	98	912.079841	128	915.113915
9	903.078755	39	906.112829	69	909.146903	99	912.180977	129	915.113915
10	903.179891	40	906.213965	70	909.248039	100	912.282113	130	915.316187
11	903.281026	41	906.315100	71	909.349175	101	912.383249	131	915.417323
12	903.382162	42	906.416236	72	909.450310	102	912.484384	132	915.518458
13	903.483298	43	906.517372	73	909.551446	103	912.585520	133	915.619594
14	903.584434	44	906.618508	74	909.652582	104	912.686656	134	915.720730
15	903.685570	45	906.719644	75	909.753718	105	912.787792	135	915.821866
16	903.786705	46	906.820779	76	909.854854	106	912.888928	136	915.923002
17	903.887841	47	906.921915	77	909.955989	107	912.990063	137	916.024138
18	903.988977	48	907.023051	78	910.057125	108	913.091199	138	916.125273
19	904.090113	49	907.124187	79	910.158261	109	913.192335	139	916.226409
20	904.191249	50	907.225323	80	910.259397	110	913.293471	140	916.327545
21	904.292384	51	907.326458	81	910.360533	111	913.394607	141	916.428681
22	904.393520	52	907.427594	82	910.461668	112	913.495742	142	916.529817
23	904.494656	53	907.528730	83	910.562804	113	913.596878	143	916.630952
24	904.595792	54	907.629866	84	910.663940	114	913.698014	144	916.732088
25	904.696928	55	907.731002	85	910.765076	115	913.799150	145	916.833224
26	904.798063	56	907.832138	86	910.866212	116	913.900286	146	916.934360
27	904.899199	57	907.933273	87	910.967347	117	914.001421	147	917.035496
28	905.000335	58	908.034409	88	911.068483	118	914.102557	148	917.136631
29	905.101471	59	908.135545	89	911.169619	119	914.203693	149	917.237767
30	905.202607	60	908.236681	90	911.270755	120	914.304829	150	917.338903



A D T

Ch.	Freq. (MHz)	Ch.	Freq. (MHz)	Ch.	Freq. (MHz)	Ch.	Freq. (MHz)	Ch.	Freq. (MHz)
151	917.440039	172	919.563891	193	921.687742	214	923.811594	235	925.935446
152	917.541175	173	919.665026	194	921.687742	215	923.912730	236	926.036582
153	917.642310	174	919.766162	195	921.890014	216	924.013866	237	926.137718
154	917.743446	175	919.867298	196	921.991150	217	924.115002	238	926.238854
155	917.844582	176	919.968434	197	922.092286	218	924.216138	239	926.339989
156	917.945718	177	920.069570	198	922.193421	219	924.317273	240	926.441125
157	918.046854	178	920.170705	199	922.294557	220	924.418409	241	926.542261
158	918.147989	179	920.271841	200	922.395693	221	924.519545	242	926.643397
159	918.249125	180	920.372977	201	922.496829	222	924.620681	243	926.744533
160	918.350261	181	920.474113	202	922.597965	223	924.721817	244	926.845668
161	918.451397	182	920.575249	203	922.699100	224	924.822952	245	926.946804
162	918.552533	183	920.676384	204	922.800236	225	924.924088	246	927.047940
163	918.653668	184	920.777520	205	922.901372	226	925.025224	247	927.149076
164	918.754804	185	920.878656	206	923.002508	227	925.126360	248	927.250212
165	918.855940	186	920.979792	207	923.103644	228	925.227496	249	927.351347
166	918.957076	187	921.080928	208	923.204779	229	925.328631	250	927.452483
167	919.058212	188	921.182063	209	923.305915	230	925.429767	251	927.553619
168	919.159347	189	921.283199	210	923.407051	231	925.530903	252	927.654755
169	919.260483	190	921.384335	211	923.508187	232	925.632039		
170	919.361619	191	921.485471	212	923.609323	233	925.733175		
171	919.462755	192	921.586607	213	923.710458	234	925.834310		

3.2.1 CONFIGURATION OF SYSTEM UNDER TEST

TEST MODE A

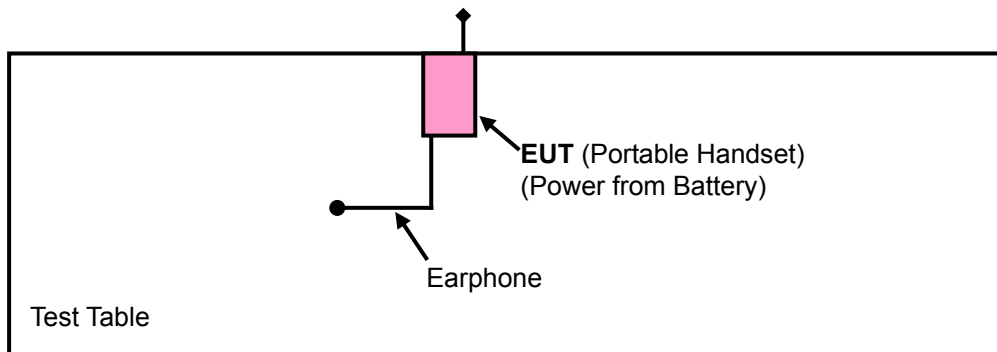

NOTE: The configuration was the worst case as above.

TEST MODE B, C

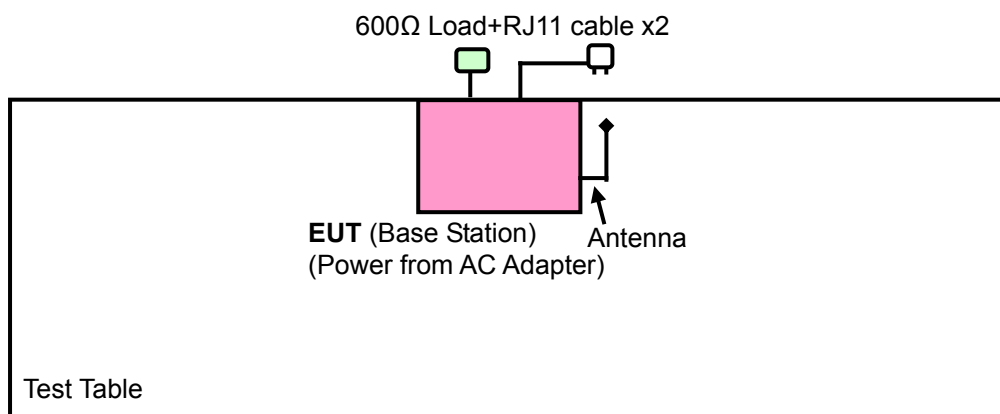

3.2.2 TEST MODE APPLICABILITY AND TESTED CHANNEL DETAIL

EUT CONFIGURE MODE	APPLICABLE TO		DESCRIPTION
	RE<1G	PLC	
A	√	√	Handset mode
B	√	√	Base Station mode with adapter 1
C	√	√	Base Station mode with adapter 2

Where **RE<1G**: Radiated Emission below 1GHz **PLC**: Power Line Conducted Emission

NOTE: “-“ means no effect

RADIATED EMISSION TEST (BELOW 1 GHz):

- Pre-Scan has been conducted to determine the worst-case mode from all possible combinations between available modulations, XYZ axis, antenna ports (if EUT with antenna diversity architecture) and packet type.

- Following channel(s) was (were) selected for the final test as listed below.

EUT CONFIGURE MODE	AVAILABLE CHANNEL	TESTED CHANNEL	MODULATION TYPE	AXIS
A	1 to 252	1, 126, 252	MSK	Y
B	1 to 252	1, 126, 252	MSK	X
C	1 to 252	1, 126, 252	MSK	X

POWER LINE CONDUCTED EMISSION TEST:

- Pre-Scan has been conducted to determine the worst-case mode from all possible combinations between available modulations, data rates and antenna ports (if EUT with antenna diversity architecture).

- Following channel(s) was (were) selected for the final test as listed below.

EUT CONFIGURE MODE	AVAILABLE CHANNEL	TESTED CHANNEL	MODULATION TYPE
A	1 to 252	1, 126, 252	MSK
B	1 to 252	1, 126, 252	MSK
C	1 to 252	1, 126, 252	MSK

TEST CONDITION:

APPLICABLE TO	ENVIRONMENTAL CONDITIONS	INPUT POWER	TESTED BY
RE<1G	25deg. C, 68%RH (Test Mode A, B) 24deg. C, 74%RH (Test Mode C)	120Vac, 60Hz	Sun Lin
PLC	22deg. C, 60%RH (Test Mode A) 23deg. C, 62%RH (Test Mode B) 24deg. C, 64%RH (Test Mode C)	120Vac, 60Hz	Antony Lee Match Tsui

3.3 GENERAL DESCRIPTION OF APPLIED STANDARDS

The EUT is a RF Product. According to the specifications of the manufacturer, it must comply with the requirements of the following standards:

FCC Part 15, Subpart C. (15.247)
ANSI C63.10-2009

All test items have been performed and recorded as per the above standards.

3.4 DESCRIPTION OF SUPPORT UNITS

The EUT has been tested as an independent unit together with other necessary accessories or support units. The following support units or accessories were used to form a representative test configuration during the tests.

NO.	PRODUCT	BRAND	MODEL NO.	SERIAL NO.	FCC ID
1	Earphone	Panasonic	KX-TCA400	NA	NA

NO.	SIGNAL CABLE DESCRIPTION OF THE ABOVE SUPPORT UNITS
1	1.2m non-shielded cable without core

NOTE: All power cords of the above support units are non-shielded (1.8 m).



4. TEST TYPES AND RESULTS

4.1 RADIATED EMISSION MEASUREMENT

4.1.1 LIMITS OF RADIATED EMISSION MEASUREMENT

Emissions radiated outside of the specified bands, shall be according to the general radiated limits in 15.209 as following:

FREQUENCIES (MHz)	FIELD STRENGTH (microvolts/meter)	MEASUREMENT DISTANCE (meters)
0.009 ~ 0.490	2400/F(kHz)	300
0.490 ~ 1.705	24000/F(kHz)	30
1.705 ~ 30.0	30	30
30 ~ 88	100	3
88 ~ 216	150	3
216 ~ 960	200	3
Above 960	500	3

NOTE:

1. The lower limit shall apply at the transition frequencies.
2. Emission level (dBuV/m) = 20 log Emission level (uV/m).
3. For frequencies above 1000MHz, the field strength limits are based on average detector, however, the peak field strength of any emission shall not exceed the maximum permitted average limits, specified above by more than 20dB under any condition of modulation.



4.1.2 TEST INSTRUMENTS

DESCRIPTION & MANUFACTURER	MODEL NO.	SERIAL NO.	DATE OF CALIBRATION	DUE DATE OF CALIBRATION
Test Receiver ROHDE & SCHWARZ	ESCI	100744	Apr. 19, 2012	Apr. 18, 2013
Spectrum Analyzer ROHDE & SCHWARZ	FSP40	100269	Jan. 30, 2012	Jan. 29, 2013
BILOG Antenna SCHWARZBECK	VULB9168	9168-156	Apr. 03, 2012	Apr. 02, 2013
HORN Antenna SCHWARZBECK	BBHA 9120 D	9120D-563	Sep. 12, 2012	Sep. 11, 2013
HORN Antenna SCHWARZBECK	BBHA 9170	148	Jul. 11, 2012	Jul. 10, 2013
Preamplifier Agilent	8449B	3008A01911	Oct. 25, 2012	Oct. 24, 2013
Preamplifier Agilent	8447D	2944A10638	Oct. 25, 2012	Oct. 24, 2013
RF signal cable HUBER+SUHNNER	SUCOFLEX 104	295013/4 283403/4	Aug. 28, 2012	Aug. 27, 2013
RF signal cable Worken	8D-FB	Cable-HYCH9-01	Aug. 11, 2012	Aug. 10, 2013
Software	ADT_Radiated_ V7.6.15.9.2	NA	NA	NA
Antenna Tower EMCO	2070/2080	512.835.4684	NA	NA
Turn Table EMCO	2087-2.03	NA	NA	NA
Antenna Tower & Turn Table Controller EMCO	2090	NA	NA	NA

- NOTE:**
1. The calibration interval of the above test instruments is 12 months and the calibrations are traceable to NML/ROC and NIST/USA.
 2. The test was performed in HwaYa Chamber 9.
 3. The horn antenna and HP preamplifier (model: 8449B) are used only for the measurement of emission frequency above 1GHz if tested.
 4. The FCC Site Registration No. is 460141.
 5. The IC Site Registration No. is IC 7450F-4.

4.1.3 TEST PROCEDURES

- a. The EUT was placed on the top of a rotating table 0.8 meters above the ground at a 3 meter semi-anechoic chamber. The table was rotated 360 degrees to determine the position of the highest radiation.
- b. The EUT was set 3 meters away from the interference-receiving antenna, which was mounted on the top of a variable-height antenna tower.
- c. The antenna is a broadband antenna, and its height is varied from one meter to four meters above the ground to determine the maximum value of the field strength. Both horizontal and vertical polarizations of the antenna are set to make the measurement.
- d. For each suspected emission, the EUT was arranged to its worst case and then the antenna was tuned to heights from 1 meter to 4 meters and the rotatable table was turned from 0 degrees to 360 degrees to find the maximum reading.
- e. The test-receiver system was set to Peak Detect Function and Specified Bandwidth with Maximum Hold Mode.
- f. If the emission level of the EUT in peak mode was lower than the limit specified, then testing could be stopped and the peak values of the EUT would be reported. Otherwise the emissions would be re-tested one by one using peak, quasi-peak or average method as specified and then reported in a data sheet.

NOTE:

1. The resolution bandwidth and video bandwidth of test receiver/spectrum analyzer is 120kHz for Quasi-peak detection at frequency below 1GHz.
2. The resolution bandwidth of test receiver/spectrum analyzer is 1 MHz and video bandwidth is 3MHz for Peak detection at frequency above 1GHz.
3. All modes of operation were investigated and the worst-case emissions are reported.

4.1.4 DEVIATION FROM TEST STANDARD

No deviation

4.1.5 TEST SETUP

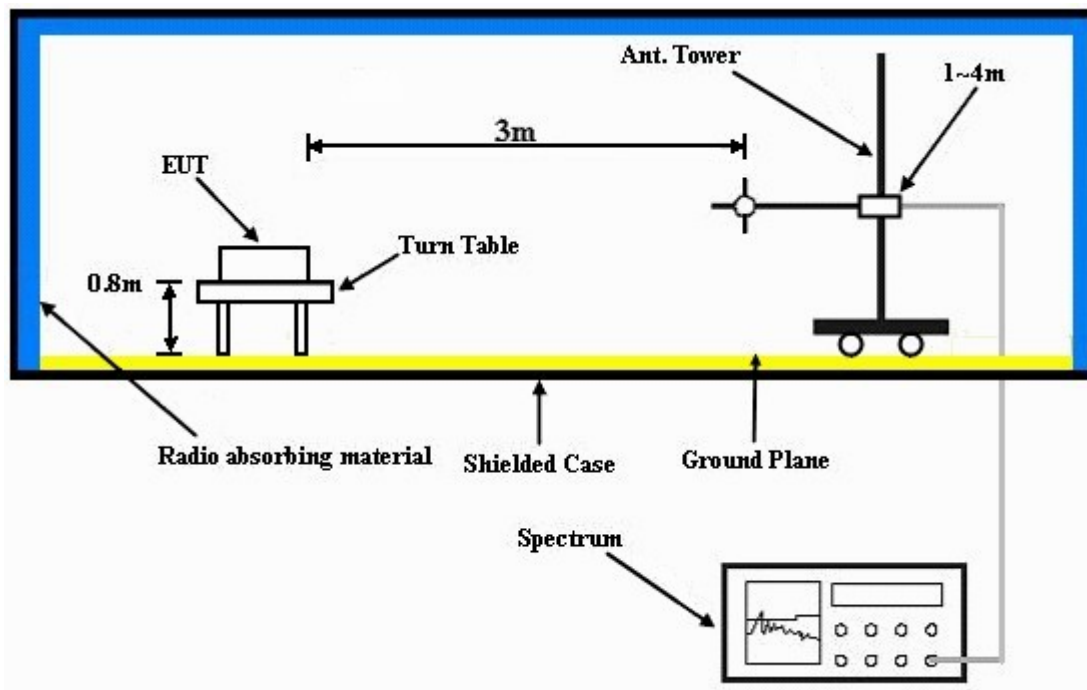

For the actual test configuration, please refer to the attached file (Test Setup Photo).

4.1.6 EUT OPERATING CONDITIONS

- Placed the EUT on a testing table.
- Set the EUT under transmission condition continuously at specific channel frequency.
- The necessary accessories enable the system in full functions.



4.1.7 TEST RESULTS

BELOW 1GHz WORST-CASE DATA

EUT TEST CONDITION		MEASUREMENT DETAIL	
CHANNEL	Channel 1	FREQUENCY RANGE	Below 1000MHz
INPUT POWER	120Vac, 60Hz	DETECTOR FUNCTION	Quasi-Peak
ENVIRONMENTAL CONDITIONS	25deg. C, 68%RH	TEST MODE	A
TESTED BY	Sun Lin		

ANTENNA POLARITY & TEST DISTANCE: HORIZONTAL AT 3 M								
NO.	FREQ. (MHz)	EMISSION LEVEL (dBuV/m)	LIMIT (dBuV/m)	MARGIN (dB)	ANTENNA HEIGHT (m)	TABLE ANGLE (Degree)	RAW VALUE (dBuV)	CORRECTION FACTOR (dB/m)
1	30.00	28.8 QP	40.0	-11.2	1.50 H	327	16.90	11.90
2	82.29	21.3 QP	40.0	-18.7	2.00 H	60	11.90	9.40
3	124.98	26.5 QP	43.5	-17.0	1.50 H	281	14.30	12.20
4	656.65	30.8 QP	46.0	-15.2	1.25 H	44	8.20	22.60
5	738.15	31.1 QP	46.0	-14.9	1.00 H	255	7.30	23.80
6	926.36	33.9 QP	46.0	-12.1	1.25 H	359	7.20	26.70
ANTENNA POLARITY & TEST DISTANCE: VERTICAL AT 3 M								
NO.	FREQ. (MHz)	EMISSION LEVEL (dBuV/m)	LIMIT (dBuV/m)	MARGIN (dB)	ANTENNA HEIGHT (m)	TABLE ANGLE (Degree)	RAW VALUE (dBuV)	CORRECTION FACTOR (dB/m)
1	30.00	34.0 QP	40.0	-6.0	1.00 V	59	22.10	11.90
2	124.98	27.7 QP	43.5	-15.8	1.00 V	291	15.50	12.20
3	575.15	26.5 QP	46.0	-19.5	1.00 V	3	4.60	21.90
4	656.65	36.1 QP	46.0	-9.9	1.25 V	45	13.50	22.60
5	738.15	32.8 QP	46.0	-13.2	1.25 V	98	9.00	23.80
6	934.13	38.3 QP	46.0	-7.7	1.00 V	1	11.50	26.80

- REMARKS:**
1. Emission level (dBuV/m) = Raw Value (dBuV) + Correction Factor (dB/m).
 2. Correction Factor (dB/m) = Antenna Factor (dB/m) + Cable Factor (dB).
 3. The other emission levels were very low against the limit.
 4. Margin value = Emission level – Limit value.



A D T

EUT TEST CONDITION		MEASUREMENT DETAIL	
CHANNEL	Channel 126	FREQUENCY RANGE	Below 1000MHz
INPUT POWER	120Vac, 60Hz	DETECTOR FUNCTION	Quasi-Peak
ENVIRONMENTAL CONDITIONS	25deg. C, 68%RH	TEST MODE	A
TESTED BY	Sun Lin		

ANTENNA POLARITY & TEST DISTANCE: HORIZONTAL AT 3 M								
NO.	FREQ. (MHz)	EMISSION LEVEL (dBuV/m)	LIMIT (dBuV/m)	MARGIN (dB)	ANTENNA HEIGHT (m)	TABLE ANGLE (Degree)	RAW VALUE (dBuV)	CORRECTION FACTOR (dB/m)
1	30.00	28.7 QP	40.0	-11.3	1.00 H	20	16.80	11.90
2	82.29	21.6 QP	40.0	-18.4	1.25 H	76	12.20	9.40
3	126.92	27.5 QP	43.5	-16.0	1.50 H	288	15.20	12.30
4	303.50	24.5 QP	46.0	-21.5	1.50 H	323	9.50	15.00
5	656.65	30.3 QP	46.0	-15.7	1.75 H	338	7.70	22.60
6	738.15	32.4 QP	46.0	-13.6	1.00 H	250	8.60	23.80
ANTENNA POLARITY & TEST DISTANCE: VERTICAL AT 3 M								
NO.	FREQ. (MHz)	EMISSION LEVEL (dBuV/m)	LIMIT (dBuV/m)	MARGIN (dB)	ANTENNA HEIGHT (m)	TABLE ANGLE (Degree)	RAW VALUE (dBuV)	CORRECTION FACTOR (dB/m)
1	30.12	35.1 QP	40.0	-4.9	1.02 V	147	23.20	11.90
2	124.98	28.7 QP	43.5	-14.8	1.25 V	288	16.50	12.20
3	575.15	26.4 QP	46.0	-19.6	1.50 V	3	4.50	21.90
4	656.65	35.1 QP	46.0	-10.9	1.75 V	3	12.50	22.60
5	738.15	32.6 QP	46.0	-13.4	1.50 V	81	8.80	23.80
6	924.42	37.3 QP	46.0	-8.7	2.00 V	345	10.60	26.70

- REMARKS:**
1. Emission level (dBuV/m) = Raw Value (dBuV) + Correction Factor (dB/m).
 2. Correction Factor (dB/m) = Antenna Factor (dB/m) + Cable Factor (dB).
 3. The other emission levels were very low against the limit.
 4. Margin value = Emission level – Limit value.



A D T

EUT TEST CONDITION		MEASUREMENT DETAIL	
CHANNEL	Channel 252	FREQUENCY RANGE	Below 1000MHz
INPUT POWER	120Vac, 60Hz	DETECTOR FUNCTION	Quasi-Peak
ENVIRONMENTAL CONDITIONS	25deg. C, 68%RH	TEST MODE	A
TESTED BY	Sun Lin		

ANTENNA POLARITY & TEST DISTANCE: HORIZONTAL AT 3 M								
NO.	FREQ. (MHz)	EMISSION LEVEL (dBuV/m)	LIMIT (dBuV/m)	MARGIN (dB)	ANTENNA HEIGHT (m)	TABLE ANGLE (Degree)	RAW VALUE (dBuV)	CORRECTION FACTOR (dB/m)
1	30.00	28.7 QP	40.0	-11.3	1.25 H	107	16.80	11.90
2	82.29	20.2 QP	40.0	-19.8	1.50 H	65	10.80	9.40
3	126.92	25.0 QP	43.5	-18.5	1.75 H	289	12.70	12.30
4	179.31	22.0 QP	43.5	-21.5	1.50 H	267	9.30	12.70
5	670.23	30.0 QP	46.0	-16.0	1.00 H	37	7.30	22.70
6	788.60	32.6 QP	46.0	-13.4	1.50 H	93	7.60	25.00
ANTENNA POLARITY & TEST DISTANCE: VERTICAL AT 3 M								
NO.	FREQ. (MHz)	EMISSION LEVEL (dBuV/m)	LIMIT (dBuV/m)	MARGIN (dB)	ANTENNA HEIGHT (m)	TABLE ANGLE (Degree)	RAW VALUE (dBuV)	CORRECTION FACTOR (dB/m)
1	30.00	34.7 QP	40.0	-5.3	1.25 V	60	22.80	11.90
2	62.89	25.4 QP	40.0	-14.6	1.00 V	217	12.30	13.10
3	124.98	29.2 QP	43.5	-14.3	1.50 V	277	17.00	12.20
4	516.94	25.2 QP	46.0	-20.8	1.75 V	177	4.70	20.50
5	670.23	34.4 QP	46.0	-11.6	2.00 V	345	11.70	22.70
6	842.93	32.4 QP	46.0	-13.6	1.25 V	4	6.60	25.80

- REMARKS:**
1. Emission level (dBuV/m) = Raw Value (dBuV) + Correction Factor (dB/m).
 2. Correction Factor (dB/m) = Antenna Factor (dB/m) + Cable Factor (dB).
 3. The other emission levels were very low against the limit.
 4. Margin value = Emission level – Limit value.



A D T

EUT TEST CONDITION		MEASUREMENT DETAIL	
CHANNEL	Channel 1	FREQUENCY RANGE	Below 1000MHz
INPUT POWER	120Vac, 60Hz	DETECTOR FUNCTION	Quasi-Peak
ENVIRONMENTAL CONDITIONS	25deg. C, 68%RH	TEST MODE	B
TESTED BY	Sun Lin		

ANTENNA POLARITY & TEST DISTANCE: HORIZONTAL AT 3 M								
NO.	FREQ. (MHz)	EMISSION LEVEL (dBuV/m)	LIMIT (dBuV/m)	MARGIN (dB)	ANTENNA HEIGHT (m)	TABLE ANGLE (Degree)	RAW VALUE (dBuV)	CORRECTION FACTOR (dB/m)
1	94.02	36.5 QP	43.5	-7.0	2.00 H	71	27.90	8.60
2	146.40	32.7 QP	43.5	-10.8	1.25 H	302	19.00	13.70
3	369.50	37.0 QP	46.0	-9.0	1.00 H	313	20.30	16.70
4	418.00	37.7 QP	46.0	-8.3	1.00 H	264	19.70	18.00
5	738.10	42.5 QP	46.0	-3.5	1.00 H	246	18.70	23.80
6	932.10	41.2 QP	46.0	-4.8	1.00 H	209	14.50	26.70
ANTENNA POLARITY & TEST DISTANCE: VERTICAL AT 3 M								
NO.	FREQ. (MHz)	EMISSION LEVEL (dBuV/m)	LIMIT (dBuV/m)	MARGIN (dB)	ANTENNA HEIGHT (m)	TABLE ANGLE (Degree)	RAW VALUE (dBuV)	CORRECTION FACTOR (dB/m)
1	64.92	32.6 QP	40.0	-7.4	1.25 V	189	19.70	12.90
2	94.02	36.7 QP	43.5	-6.8	1.00 V	63	28.10	8.60
3	140.58	27.4 QP	43.5	-16.1	1.25 V	11	13.90	13.50
4	344.28	31.0 QP	46.0	-15.0	1.25 V	7	14.90	16.10
5	377.26	32.5 QP	46.0	-13.5	1.25 V	136	15.60	16.90
6	410.24	33.6 QP	46.0	-12.4	1.25 V	108	15.80	17.80

- REMARKS:**
1. Emission level (dBuV/m) = Raw Value (dBuV) + Correction Factor (dB/m).
 2. Correction Factor (dB/m) = Antenna Factor (dB/m) + Cable Factor (dB).
 3. The other emission levels were very low against the limit.
 4. Margin value = Emission level – Limit value.



A D T

EUT TEST CONDITION		MEASUREMENT DETAIL	
CHANNEL	Channel 126	FREQUENCY RANGE	Below 1000MHz
INPUT POWER	120Vac, 60Hz	DETECTOR FUNCTION	Quasi-Peak
ENVIRONMENTAL CONDITIONS	25deg. C, 68%RH	TEST MODE	B
TESTED BY	Sun Lin		

ANTENNA POLARITY & TEST DISTANCE: HORIZONTAL AT 3 M								
NO.	FREQ. (MHz)	EMISSION LEVEL (dBuV/m)	LIMIT (dBuV/m)	MARGIN (dB)	ANTENNA HEIGHT (m)	TABLE ANGLE (Degree)	RAW VALUE (dBuV)	CORRECTION FACTOR (dB/m)
1	94.02	36.5 QP	43.5	-7.0	2.00 H	76	27.90	8.60
2	161.92	31.1 QP	43.5	-12.4	1.50 H	265	17.30	13.80
3	278.32	30.4 QP	46.0	-15.6	1.00 H	202	16.30	14.10
4	344.28	32.3 QP	46.0	-13.7	1.00 H	171	16.20	16.10
5	377.26	33.7 QP	46.0	-12.3	1.00 H	313	16.80	16.90
6	410.24	33.2 QP	46.0	-12.8	2.00 H	262	15.40	17.80
ANTENNA POLARITY & TEST DISTANCE: VERTICAL AT 3 M								
NO.	FREQ. (MHz)	EMISSION LEVEL (dBuV/m)	LIMIT (dBuV/m)	MARGIN (dB)	ANTENNA HEIGHT (m)	TABLE ANGLE (Degree)	RAW VALUE (dBuV)	CORRECTION FACTOR (dB/m)
1	64.92	33.2 QP	40.0	-6.8	1.00 V	178	20.30	12.90
2	94.02	37.1 QP	43.5	-6.4	1.25 V	4	28.50	8.60
3	146.40	27.1 QP	43.5	-16.4	1.00 V	7	13.40	13.70
4	344.28	30.6 QP	46.0	-15.4	1.25 V	16	14.50	16.10
5	377.26	33.0 QP	46.0	-13.0	1.00 V	32	16.10	16.90
6	410.24	32.8 QP	46.0	-13.2	1.25 V	118	15.00	17.80

- REMARKS:**
1. Emission level (dBuV/m) = Raw Value (dBuV) + Correction Factor (dB/m).
 2. Correction Factor (dB/m) = Antenna Factor (dB/m) + Cable Factor (dB).
 3. The other emission levels were very low against the limit.
 4. Margin value = Emission level – Limit value.



A D T

EUT TEST CONDITION		MEASUREMENT DETAIL	
CHANNEL	Channel 252	FREQUENCY RANGE	Below 1000MHz
INPUT POWER	120Vac, 60Hz	DETECTOR FUNCTION	Quasi-Peak
ENVIRONMENTAL CONDITIONS	25deg. C, 68%RH	TEST MODE	B
TESTED BY	Sun Lin		

ANTENNA POLARITY & TEST DISTANCE: HORIZONTAL AT 3 M								
NO.	FREQ. (MHz)	EMISSION LEVEL (dBuV/m)	LIMIT (dBuV/m)	MARGIN (dB)	ANTENNA HEIGHT (m)	TABLE ANGLE (Degree)	RAW VALUE (dBuV)	CORRECTION FACTOR (dB/m)
1	94.02	37.2 QP	43.5	-6.3	2.00 H	284	28.60	8.60
2	161.92	31.3 QP	43.5	-12.2	2.00 H	270	17.50	13.80
3	278.32	30.8 QP	46.0	-15.2	1.00 H	186	16.70	14.10
4	344.28	32.5 QP	46.0	-13.5	1.00 H	171	16.40	16.10
5	377.26	33.5 QP	46.0	-12.5	1.00 H	315	16.60	16.90
6	410.24	32.7 QP	46.0	-13.3	2.00 H	267	14.90	17.80
ANTENNA POLARITY & TEST DISTANCE: VERTICAL AT 3 M								
NO.	FREQ. (MHz)	EMISSION LEVEL (dBuV/m)	LIMIT (dBuV/m)	MARGIN (dB)	ANTENNA HEIGHT (m)	TABLE ANGLE (Degree)	RAW VALUE (dBuV)	CORRECTION FACTOR (dB/m)
1	64.92	32.7 QP	40.0	-7.3	1.00 V	14	19.80	12.90
2	94.02	37.4 QP	43.5	-6.1	1.00 V	34	28.80	8.60
3	146.40	27.6 QP	43.5	-15.9	1.00 V	66	13.90	13.70
4	344.28	31.2 QP	46.0	-14.8	1.50 V	13	15.10	16.10
5	377.26	32.8 QP	46.0	-13.2	1.25 V	142	15.90	16.90
6	410.24	33.8 QP	46.0	-12.2	1.00 V	120	16.00	17.80

- REMARKS:**
1. Emission level (dBuV/m) = Raw Value (dBuV) + Correction Factor (dB/m).
 2. Correction Factor (dB/m) = Antenna Factor (dB/m) + Cable Factor (dB).
 3. The other emission levels were very low against the limit.
 4. Margin value = Emission level – Limit value.



A D T

EUT TEST CONDITION		MEASUREMENT DETAIL	
CHANNEL	Channel 1	FREQUENCY RANGE	Below 1000MHz
INPUT POWER	120Vac, 60Hz	DETECTOR FUNCTION	Quasi-Peak
ENVIRONMENTAL CONDITIONS	24deg. C, 74%RH	TEST MODE	C
TESTED BY	Sun Lin		

ANTENNA POLARITY & TEST DISTANCE: HORIZONTAL AT 3 M								
NO.	FREQ. (MHz)	EMISSION LEVEL (dBuV/m)	LIMIT (dBuV/m)	MARGIN (dB)	ANTENNA HEIGHT (m)	TABLE ANGLE (Degree)	RAW VALUE (dBuV)	CORRECTION FACTOR (dB/m)
1	113.34	26.8 QP	43.5	-16.7	1.50 H	121	15.90	10.90
2	146.32	31.8 QP	43.5	-11.7	2.00 H	94	18.10	13.70
3	245.28	30.1 QP	46.0	-15.9	1.25 H	99	17.30	12.80
4	311.26	30.5 QP	46.0	-15.5	1.00 H	315	15.30	15.20
5	344.24	32.9 QP	46.0	-13.1	1.00 H	305	16.80	16.10
6	377.23	34.4 QP	46.0	-11.6	1.00 H	326	17.50	16.90
ANTENNA POLARITY & TEST DISTANCE: VERTICAL AT 3 M								
NO.	FREQ. (MHz)	EMISSION LEVEL (dBuV/m)	LIMIT (dBuV/m)	MARGIN (dB)	ANTENNA HEIGHT (m)	TABLE ANGLE (Degree)	RAW VALUE (dBuV)	CORRECTION FACTOR (dB/m)
1	59.01	28.4 QP	40.0	-11.6	1.00 V	139	15.00	13.40
2	146.32	27.4 QP	43.5	-16.1	2.00 V	16	13.70	13.70
3	189.01	29.4 QP	43.5	-14.1	2.00 V	16	17.40	12.00
4	344.24	31.3 QP	46.0	-14.7	1.25 V	332	15.20	16.10
5	377.23	35.3 QP	46.0	-10.7	1.25 V	16	18.40	16.90
6	410.22	34.0 QP	46.0	-12.0	1.50 V	139	16.20	17.80

- REMARKS:**
1. Emission level (dBuV/m) = Raw Value (dBuV) + Correction Factor (dB/m).
 2. Correction Factor (dB/m) = Antenna Factor (dB/m) + Cable Factor (dB).
 3. The other emission levels were very low against the limit.
 4. Margin value = Emission level – Limit value.



A D T

EUT TEST CONDITION		MEASUREMENT DETAIL	
CHANNEL	Channel 126	FREQUENCY RANGE	Below 1000MHz
INPUT POWER	120Vac, 60Hz	DETECTOR FUNCTION	Quasi-Peak
ENVIRONMENTAL CONDITIONS	24deg. C, 74%RH	TEST MODE	C
TESTED BY	Sun Lin		

ANTENNA POLARITY & TEST DISTANCE: HORIZONTAL AT 3 M								
NO.	FREQ. (MHz)	EMISSION LEVEL (dBuV/m)	LIMIT (dBuV/m)	MARGIN (dB)	ANTENNA HEIGHT (m)	TABLE ANGLE (Degree)	RAW VALUE (dBuV)	CORRECTION FACTOR (dB/m)
1	113.34	27.2 QP	43.5	-16.3	1.50 H	139	16.30	10.90
2	146.32	31.7 QP	43.5	-11.8	2.00 H	95	18.00	13.70
3	245.28	29.7 QP	46.0	-16.3	1.25 H	87	16.90	12.80
4	311.26	31.0 QP	46.0	-15.0	1.00 H	327	15.80	15.20
5	377.23	34.3 QP	46.0	-11.7	1.00 H	323	17.40	16.90
6	410.22	30.5 QP	46.0	-15.5	1.00 H	278	12.70	17.80
ANTENNA POLARITY & TEST DISTANCE: VERTICAL AT 3 M								
NO.	FREQ. (MHz)	EMISSION LEVEL (dBuV/m)	LIMIT (dBuV/m)	MARGIN (dB)	ANTENNA HEIGHT (m)	TABLE ANGLE (Degree)	RAW VALUE (dBuV)	CORRECTION FACTOR (dB/m)
1	59.01	29.0 QP	40.0	-11.0	1.00 V	184	15.60	13.40
2	169.61	31.4 QP	43.5	-12.1	1.50 V	228	17.90	13.50
3	189.01	29.2 QP	43.5	-14.3	2.00 V	9	17.20	12.00
4	377.23	34.5 QP	46.0	-11.5	1.25 V	16	17.60	16.90
5	410.22	33.5 QP	46.0	-12.5	1.25 V	129	15.70	17.80
6	443.21	31.2 QP	46.0	-14.8	1.00 V	8	12.60	18.60

- REMARKS:**
1. Emission level (dBuV/m) = Raw Value (dBuV) + Correction Factor (dB/m).
 2. Correction Factor (dB/m) = Antenna Factor (dB/m) + Cable Factor (dB).
 3. The other emission levels were very low against the limit.
 4. Margin value = Emission level – Limit value.



A D T

EUT TEST CONDITION		MEASUREMENT DETAIL	
CHANNEL	Channel 252	FREQUENCY RANGE	Below 1000MHz
INPUT POWER	120Vac, 60Hz	DETECTOR FUNCTION	Quasi-Peak
ENVIRONMENTAL CONDITIONS	24deg. C, 74%RH	TEST MODE	C
TESTED BY	Sun Lin		

ANTENNA POLARITY & TEST DISTANCE: HORIZONTAL AT 3 M								
NO.	FREQ. (MHz)	EMISSION LEVEL (dBuV/m)	LIMIT (dBuV/m)	MARGIN (dB)	ANTENNA HEIGHT (m)	TABLE ANGLE (Degree)	RAW VALUE (dBuV)	CORRECTION FACTOR (dB/m)
1	146.32	31.4 QP	43.5	-12.1	2.00 H	102	17.70	13.70
2	245.28	30.8 QP	46.0	-15.2	1.25 H	100	18.00	12.80
3	344.24	31.6 QP	46.0	-14.4	1.00 H	321	15.50	16.10
4	377.23	34.3 QP	46.0	-11.7	1.00 H	342	17.40	16.90
5	410.22	31.0 QP	46.0	-15.0	2.00 H	272	13.20	17.80
6	707.10	27.1 QP	46.0	-18.9	1.00 H	237	4.10	23.00
ANTENNA POLARITY & TEST DISTANCE: VERTICAL AT 3 M								
NO.	FREQ. (MHz)	EMISSION LEVEL (dBuV/m)	LIMIT (dBuV/m)	MARGIN (dB)	ANTENNA HEIGHT (m)	TABLE ANGLE (Degree)	RAW VALUE (dBuV)	CORRECTION FACTOR (dB/m)
1	60.95	28.9 QP	40.0	-11.1	1.00 V	150	15.60	13.30
2	113.34	26.8 QP	43.5	-16.7	1.00 V	207	15.90	10.90
3	189.01	29.5 QP	43.5	-14.0	1.00 V	199	17.50	12.00
4	377.23	35.7 QP	46.0	-10.3	1.00 V	16	18.80	16.90
5	410.22	34.0 QP	46.0	-12.0	1.00 V	16	16.20	17.80
6	443.21	30.9 QP	46.0	-15.1	1.00 V	355	12.30	18.60

- REMARKS:**
1. Emission level (dBuV/m) = Raw Value (dBuV) + Correction Factor (dB/m).
 2. Correction Factor (dB/m) = Antenna Factor (dB/m) + Cable Factor (dB).
 3. The other emission levels were very low against the limit.
 4. Margin value = Emission level – Limit value.

4.2 CONDUCTED EMISSION MEASUREMENT

4.2.1 LIMITS OF CONDUCTED EMISSION MEASUREMENT

FREQUENCY OF EMISSION (MHz)	CONDUCTED LIMIT (dB μ V)	
	Quasi-peak	Average
0.15-0.5	66 to 56	56 to 46
0.5-5	56	46
5-30	60	50

- NOTE:**
1. The lower limit shall apply at the transition frequencies.
 2. The limit decreases in line with the logarithm of the frequency in the range of 0.15 to 0.50 MHz.
 3. All emanations from a class A/B digital device or system, including any network of conductors and apparatus connected thereto, shall not exceed the level of field strengths specified above.

4.2.2 TEST INSTRUMENTS

DESCRIPTION & MANUFACTURER	MODEL NO.	SERIAL NO.	DATE OF CALIBRATION	DUE DATE OF CALIBRATION
Test Receiver ROHDE & SCHWARZ	ESCS30	100288	Nov. 09, 2012	Nov. 08, 2013
RF signal cable Woken	5D-FB	Cable-HYCO2-01	Dec. 29, 2011	Dec. 28, 2012
LISN ROHDE & SCHWARZ (EUT)	ESH2-Z5	100100	Dec. 30, 2011	Dec. 29, 2012
LISN ROHDE & SCHWARZ (Peripheral)	ESH3-Z5	100311	Jul. 06, 2012	Jul. 05, 2013
Software ADT	BV ADT_Cond_ V7.3.7.3	NA	NA	NA

- NOTE:**
1. The calibration interval of the above test instruments is 12 months and the calibrations are traceable to NML/ROC and NIST/USA.
 2. The test was performed in HwaYa Shielded Room 2.
 3. The VCCI Site Registration No. is C-2047.



A D T

4.2.3 TEST PROCEDURES

- a. The EUT was placed 0.4 meters from the conducting wall of the shielded room with EUT being connected to the power mains through a line impedance stabilization network (LISN). Other support units were connected to the power mains through another LISN. The two LISNs provide 50 ohm/ 50uH of coupling impedance for the measuring instrument.
- b. Both lines of the power mains connected to the EUT were checked for maximum conducted interference.
- c. The frequency range from 150kHz to 30MHz was searched. Emission levels under (Limit - 20dB) was not recorded.

NOTE: All modes of operation were investigated and the worst-case emissions are reported.

4.2.4 DEVIATION FROM TEST STANDARD

No deviation.

4.2.5 TEST SETUP

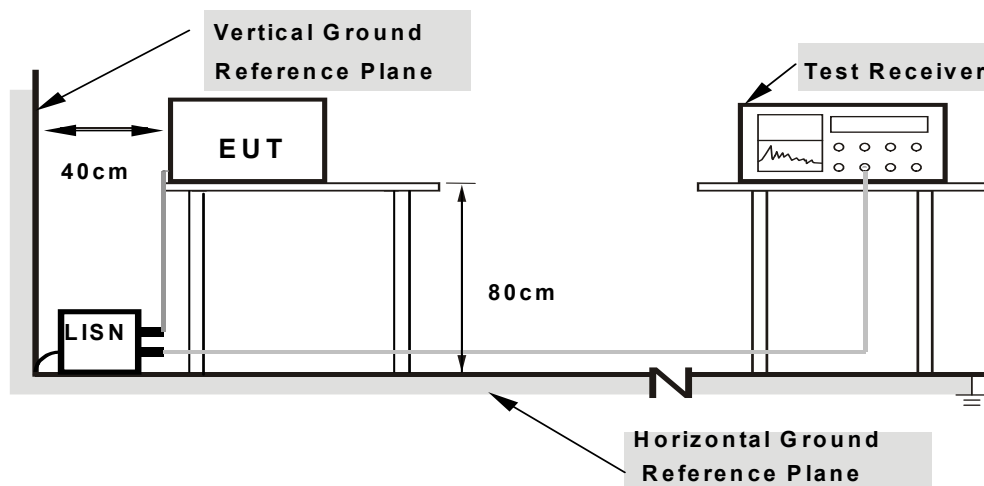

- Note:**
1. Support units were connected to second LISN.
 2. Both of LISNs (AMN) are 80 cm from EUT and at least 80 cm from other units and other metal planes

For the actual test configuration, please refer to the attached file (Test Setup Photo).

4.2.6 EUT OPERATING CONDITIONS

Same as 4.1.6.

4.2.7 TEST RESULTS

CONDUCTED WORST-CASE DATA

CHANNEL	Channel 1	6dB BANDWIDTH	9kHz
PHASE	Line 1	TEST MODE	A

No	Freq. [MHz]	Corr. Factor (dB)	Reading Value		Emission Level		Limit		Margin	
			[dB (uV)]		[dB (uV)]		[dB (uV)]		(dB)	
			Q.P.	AV.	Q.P.	AV.	Q.P.	AV.	Q.P.	AV.
1	0.16562	0.15	44.48	36.94	44.63	37.09	65.18	55.18	-20.55	-18.09
2	0.32578	0.16	42.06	30.72	42.22	30.88	59.56	49.56	-17.34	-18.68
3	0.45859	0.17	35.65	22.98	35.82	23.15	56.72	46.72	-20.90	-23.57
4	0.80625	0.18	32.98	21.46	33.16	21.64	56.00	46.00	-22.84	-24.36
5	5.27734	0.36	35.96	26.74	36.32	27.10	60.00	50.00	-23.68	-22.90
6	12.48828	0.48	36.45	28.20	36.93	28.68	60.00	50.00	-23.07	-21.32

REMARKS:

1. Q.P. and AV. are abbreviations of quasi-peak and average individually.
2. The emission levels of other frequencies were very low against the limit.
3. Margin value = Emission level - Limit value
4. Correction factor = Insertion loss + Cable loss
5. Emission Level = Correction Factor + Reading Value.

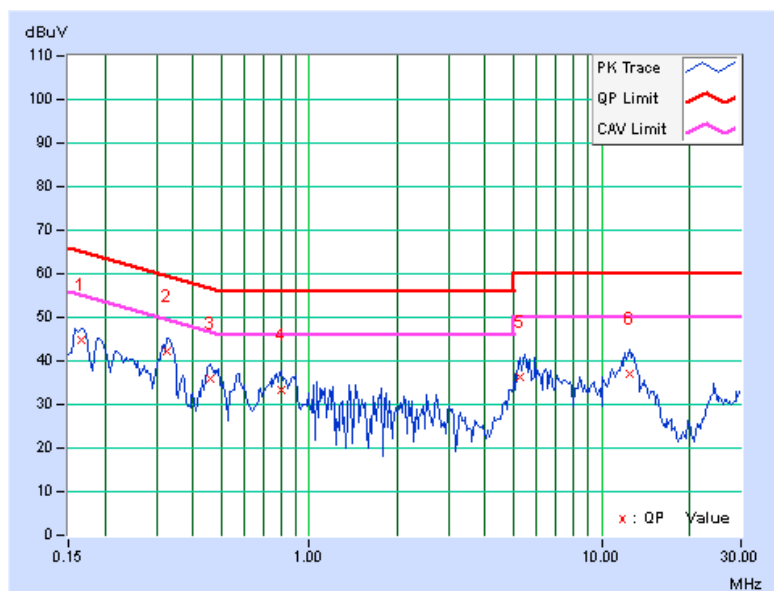

CHANNEL	Channel 1	6dB BANDWIDTH	9kHz
PHASE	Line 2	TEST MODE	A

No	Freq. [MHz]	Corr. Factor (dB)	Reading Value		Emission Level		Limit		Margin	
			[dB (uV)]		[dB (uV)]		[dB (uV)]		(dB)	
			Q.P.	AV.	Q.P.	AV.	Q.P.	AV.	Q.P.	AV.
1	0.16562	0.13	49.52	32.58	49.65	32.71	65.18	55.18	-15.52	-22.46
2	0.19297	0.14	46.35	30.08	46.49	30.22	63.91	53.91	-17.42	-23.69
3	0.31779	0.15	37.71	28.78	37.86	28.93	59.76	49.76	-21.90	-20.83
4	5.32422	0.38	32.50	24.08	32.88	24.46	60.00	50.00	-27.12	-25.54
5	12.68750	0.54	31.73	24.35	32.27	24.89	60.00	50.00	-27.73	-25.11
6	29.13672	0.55	29.92	18.37	30.47	18.92	60.00	50.00	-29.53	-31.08

REMARKS:

1. Q.P. and AV. are abbreviations of quasi-peak and average individually.
2. The emission levels of other frequencies were very low against the limit.
3. Margin value = Emission level - Limit value
4. Correction factor = Insertion loss + Cable loss
5. Emission Level = Correction Factor + Reading Value.

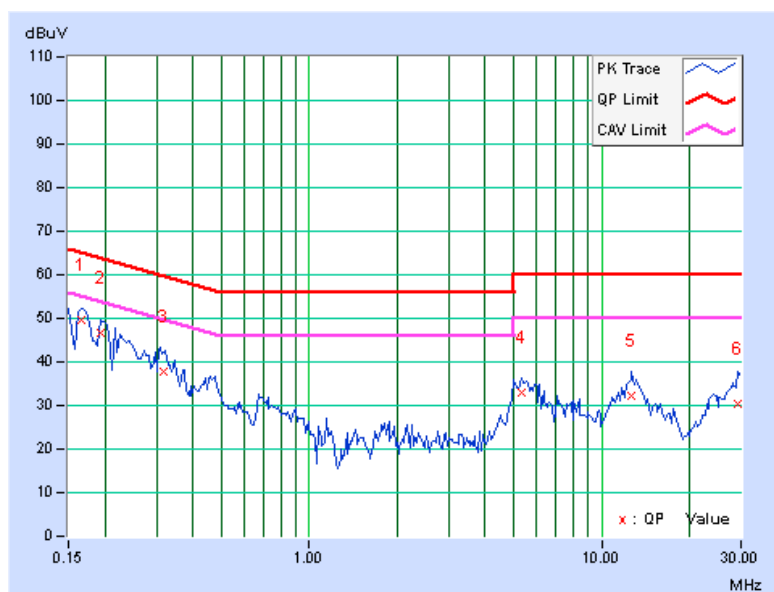

CHANNEL	Channel 126	6dB BANDWIDTH	9kHz
PHASE	Line 1	TEST MODE	A

No	Freq. [MHz]	Corr. Factor (dB)	Reading Value		Emission Level		Limit		Margin	
			[dB (uV)]		[dB (uV)]		[dB (uV)]		(dB)	
			Q.P.	AV.	Q.P.	AV.	Q.P.	AV.	Q.P.	AV.
1	0.16172	0.15	42.37	33.78	42.52	33.93	65.38	55.38	-22.86	-21.45
2	0.32188	0.16	40.16	30.84	40.32	31.00	59.66	49.66	-19.34	-18.66
3	0.79063	0.18	28.59	17.32	28.77	17.50	56.00	46.00	-27.23	-28.50
4	0.89219	0.19	29.63	20.21	29.82	20.40	56.00	46.00	-26.18	-25.60
5	5.44531	0.36	34.57	25.93	34.93	26.29	60.00	50.00	-25.07	-23.71
6	12.70313	0.48	35.48	27.46	35.96	27.94	60.00	50.00	-24.04	-22.06

REMARKS:

1. Q.P. and AV. are abbreviations of quasi-peak and average individually.
2. The emission levels of other frequencies were very low against the limit.
3. Margin value = Emission level - Limit value
4. Correction factor = Insertion loss + Cable loss
5. Emission Level = Correction Factor + Reading Value.

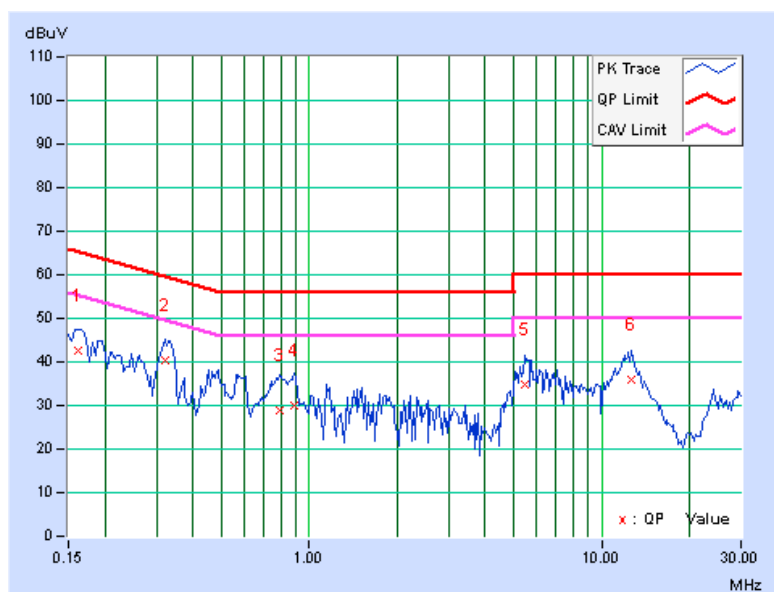

CHANNEL	Channel 126	6dB BANDWIDTH	9kHz
PHASE	Line 2	TEST MODE	A

No	Freq. [MHz]	Corr. Factor (dB)	Reading Value		Emission Level		Limit		Margin	
			[dB (uV)]		[dB (uV)]		[dB (uV)]		(dB)	
			Q.P.	AV.	Q.P.	AV.	Q.P.	AV.	Q.P.	AV.
1	0.15000	0.13	43.64	31.47	43.77	31.60	66.00	56.00	-22.23	-24.40
2	0.26328	0.15	35.25	25.14	35.40	25.29	61.33	51.33	-25.93	-26.04
3	0.31797	0.15	34.67	25.82	34.82	25.97	59.76	49.76	-24.94	-23.79
4	0.48203	0.16	26.51	13.47	26.67	13.63	56.30	46.30	-29.63	-32.67
5	5.42188	0.38	30.53	22.38	30.91	22.76	60.00	50.00	-29.09	-27.24
6	12.44531	0.54	30.67	22.52	31.21	23.06	60.00	50.00	-28.79	-26.94

REMARKS:

1. Q.P. and AV. are abbreviations of quasi-peak and average individually.
2. The emission levels of other frequencies were very low against the limit.
3. Margin value = Emission level - Limit value
4. Correction factor = Insertion loss + Cable loss
5. Emission Level = Correction Factor + Reading Value.

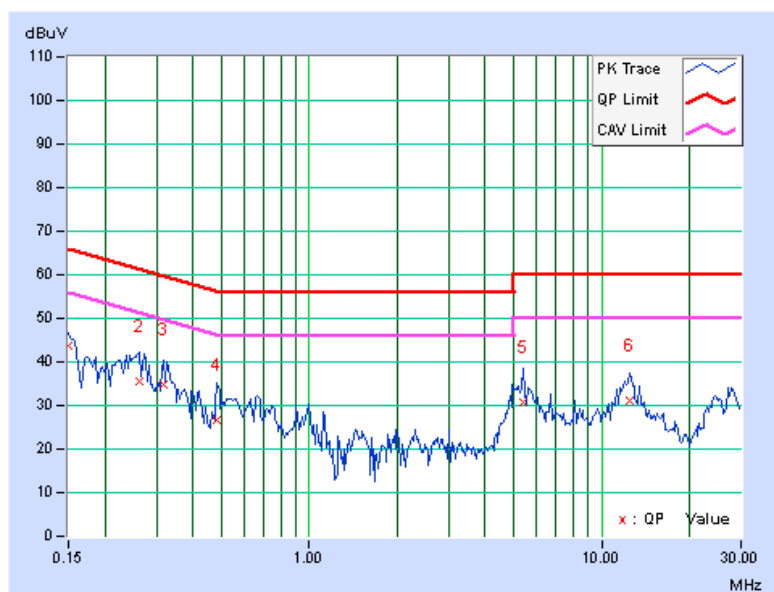

CHANNEL	Channel 252	6dB BANDWIDTH	9kHz
PHASE	Line 1	TEST MODE	A

No	Freq. [MHz]	Corr. Factor (dB)	Reading Value		Emission Level		Limit		Margin	
			[dB (uV)]		[dB (uV)]		[dB (uV)]		(dB)	
			Q.P.	AV.	Q.P.	AV.	Q.P.	AV.	Q.P.	AV.
1	0.15100	0.15	42.60	34.23	42.75	34.38	65.94	55.94	-23.19	-21.56
2	0.32578	0.16	39.37	28.54	39.53	28.70	59.56	49.56	-20.03	-20.86
3	0.47813	0.17	31.49	21.15	31.66	21.32	56.37	46.37	-24.71	-25.05
4	0.90391	0.19	30.93	19.17	31.12	19.36	56.00	46.00	-24.88	-26.64
5	5.24219	0.36	32.86	23.50	33.22	23.86	60.00	50.00	-26.78	-26.14
6	12.46484	0.48	35.40	26.70	35.88	27.18	60.00	50.00	-24.12	-22.82

REMARKS:

1. Q.P. and AV. are abbreviations of quasi-peak and average individually.
2. The emission levels of other frequencies were very low against the limit.
3. Margin value = Emission level - Limit value
4. Correction factor = Insertion loss + Cable loss
5. Emission Level = Correction Factor + Reading Value.

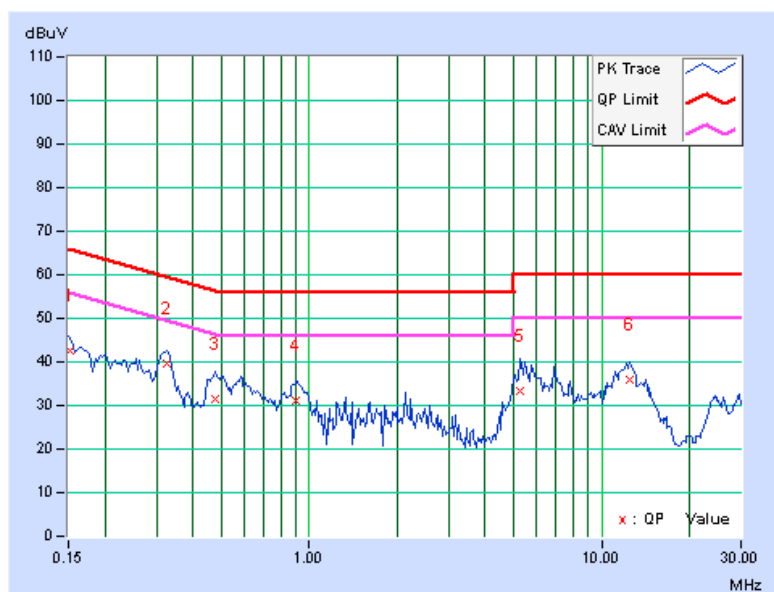

CHANNEL	Channel 252	6dB BANDWIDTH	9kHz
PHASE	Line 2	TEST MODE	A

No	Freq. [MHz]	Corr. Factor (dB)	Reading Value		Emission Level		Limit		Margin	
			[dB (uV)]		[dB (uV)]		[dB (uV)]		(dB)	
			Q.P.	AV.	Q.P.	AV.	Q.P.	AV.	Q.P.	AV.
1	0.15781	0.13	42.98	29.09	43.11	29.22	65.58	55.58	-22.47	-26.36
2	0.25547	0.15	35.73	25.04	35.88	25.19	61.58	51.58	-25.70	-26.39
3	0.32188	0.15	35.03	26.18	35.18	26.33	59.66	49.66	-24.48	-23.33
4	0.55625	0.17	27.81	16.48	27.98	16.65	56.00	46.00	-28.02	-29.35
5	5.31250	0.38	29.69	20.90	30.07	21.28	60.00	50.00	-29.93	-28.72
6	12.87500	0.55	28.75	21.64	29.30	22.19	60.00	50.00	-30.70	-27.81

REMARKS:

1. Q.P. and AV. are abbreviations of quasi-peak and average individually.
2. The emission levels of other frequencies were very low against the limit.
3. Margin value = Emission level - Limit value
4. Correction factor = Insertion loss + Cable loss
5. Emission Level = Correction Factor + Reading Value.

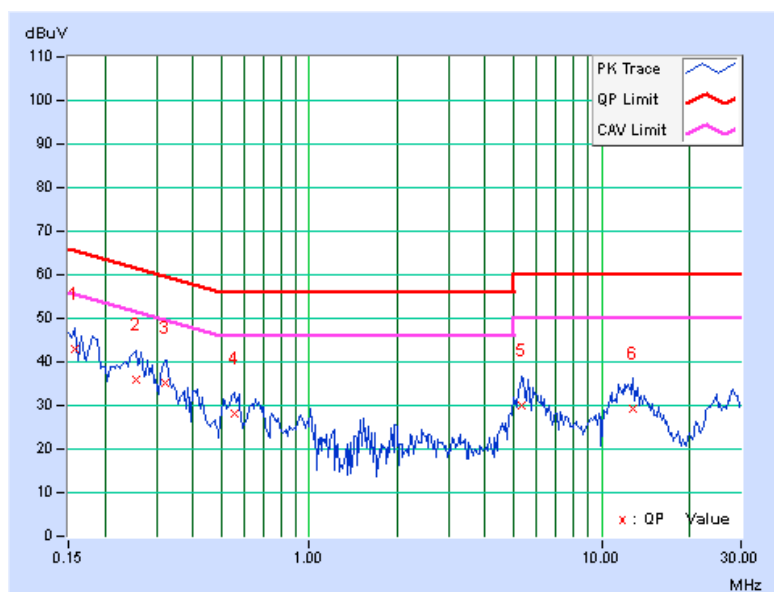

CHANNEL	Channel 1	6dB BANDWIDTH	9kHz
PHASE	Line 1	TEST MODE	B

No	Freq. [MHz]	Corr. Factor (dB)	Reading Value		Emission Level		Limit		Margin	
			[dB (uV)]		[dB (uV)]		[dB (uV)]		(dB)	
			Q.P.	AV.	Q.P.	AV.	Q.P.	AV.	Q.P.	AV.
1	0.16953	0.15	55.73	43.14	55.88	43.29	64.98	54.98	-9.10	-11.69
2	0.22422	0.15	51.22	37.55	51.37	37.70	62.66	52.66	-11.29	-14.96
3	0.53672	0.17	52.75	42.61	52.92	42.78	56.00	46.00	-3.08	-3.22
4	0.78281	0.18	47.36	38.01	47.54	38.19	56.00	46.00	-8.46	-7.81
5	1.66406	0.24	37.00	30.69	37.24	30.93	56.00	46.00	-18.76	-15.07
6	11.47656	0.46	46.01	41.03	46.47	41.49	60.00	50.00	-13.53	-8.51

REMARKS:

1. Q.P. and AV. are abbreviations of quasi-peak and average individually.
2. The emission levels of other frequencies were very low against the limit.
3. Margin value = Emission level - Limit value
4. Correction factor = Insertion loss + Cable loss
5. Emission Level = Correction Factor + Reading Value.

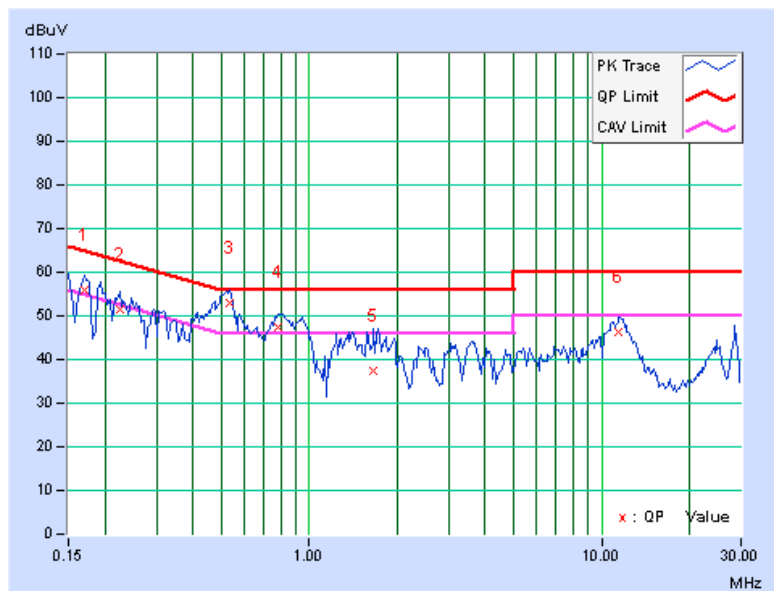

CHANNEL	Channel 1	6dB BANDWIDTH	9kHz
PHASE	Line 2	TEST MODE	B

No	Freq. [MHz]	Corr. Factor (dB)	Reading Value		Emission Level		Limit		Margin	
			[dB (uV)]		[dB (uV)]		[dB (uV)]		(dB)	
			Q.P.	AV.	Q.P.	AV.	Q.P.	AV.	Q.P.	AV.
1	0.15100	0.13	62.09	44.67	62.22	44.80	65.94	55.94	-3.72	-11.14
2	0.16953	0.13	55.85	40.46	55.98	40.59	64.98	54.98	-9.00	-14.39
3	0.52500	0.17	54.14	44.10	54.31	44.27	56.00	46.00	-1.69	-1.73
4	0.70859	0.18	46.52	35.51	46.70	35.69	56.00	46.00	-9.30	-10.31
5	1.37891	0.22	46.75	36.67	46.97	36.89	56.00	46.00	-9.03	-9.11
6	11.03516	0.50	47.08	42.41	47.58	42.91	60.00	50.00	-12.42	-7.09

REMARKS:

1. Q.P. and AV. are abbreviations of quasi-peak and average individually.
2. The emission levels of other frequencies were very low against the limit.
3. Margin value = Emission level - Limit value
4. Correction factor = Insertion loss + Cable loss
5. Emission Level = Correction Factor + Reading Value.

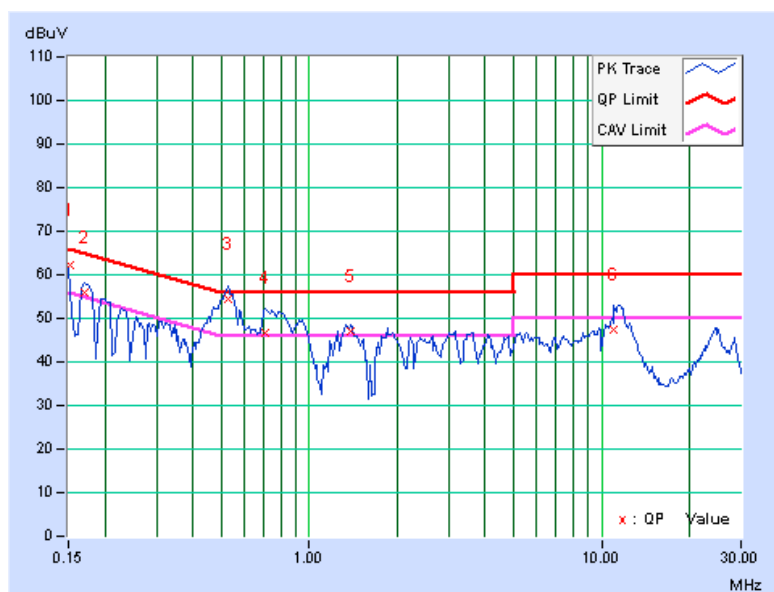

CHANNEL	Channel 126	6dB BANDWIDTH	9kHz
PHASE	Line 1	TEST MODE	B

No	Freq. [MHz]	Corr. Factor (dB)	Reading Value		Emission Level		Limit		Margin	
			[dB (uV)]		[dB (uV)]		[dB (uV)]		(dB)	
			Q.P.	AV.	Q.P.	AV.	Q.P.	AV.	Q.P.	AV.
1	0.17344	0.15	55.28	43.83	55.43	43.98	64.79	54.79	-9.36	-10.81
2	0.20859	0.15	49.78	33.76	49.93	33.91	63.26	53.26	-13.33	-19.35
3	0.50547	0.17	51.81	42.45	51.98	42.62	56.00	46.00	-4.02	-3.38
4	0.80234	0.18	47.66	38.41	47.84	38.59	56.00	46.00	-8.16	-7.41
5	1.40234	0.22	45.14	36.81	45.36	37.03	56.00	46.00	-10.64	-8.97
6	11.13672	0.45	45.44	40.10	45.89	40.55	60.00	50.00	-14.11	-9.45

REMARKS:

1. Q.P. and AV. are abbreviations of quasi-peak and average individually.
2. The emission levels of other frequencies were very low against the limit.
3. Margin value = Emission level - Limit value
4. Correction factor = Insertion loss + Cable loss
5. Emission Level = Correction Factor + Reading Value.

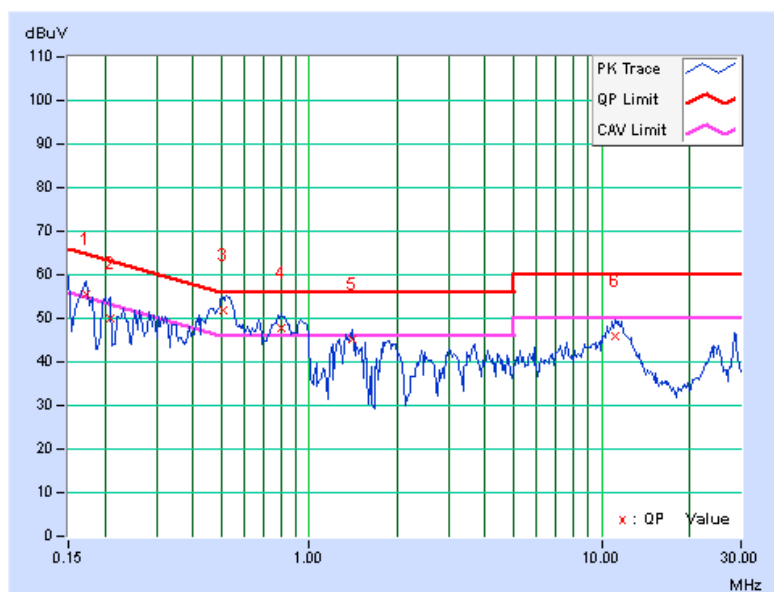

CHANNEL	Channel 126	6dB BANDWIDTH	9kHz
PHASE	Line 2	TEST MODE	B

No	Freq. [MHz]	Corr. Factor (dB)	Reading Value		Emission Level		Limit		Margin	
			[dB (uV)]		[dB (uV)]		[dB (uV)]		(dB)	
			Q.P.	AV.	Q.P.	AV.	Q.P.	AV.	Q.P.	AV.
1	0.18125	0.14	52.77	33.74	52.91	33.88	64.43	54.43	-11.52	-20.55
2	0.52109	0.17	54.30	43.93	54.47	44.10	56.00	46.00	-1.53	-1.90
3	0.78281	0.18	47.70	37.55	47.88	37.73	56.00	46.00	-8.12	-8.27
4	1.40234	0.22	46.65	38.35	46.87	38.57	56.00	46.00	-9.13	-7.43
5	3.18750	0.31	42.67	36.70	42.98	37.01	56.00	46.00	-13.02	-8.99
6	11.37500	0.51	47.98	43.35	48.49	43.86	60.00	50.00	-11.51	-6.14

REMARKS:

1. Q.P. and AV. are abbreviations of quasi-peak and average individually.
2. The emission levels of other frequencies were very low against the limit.
3. Margin value = Emission level - Limit value
4. Correction factor = Insertion loss + Cable loss
5. Emission Level = Correction Factor + Reading Value.

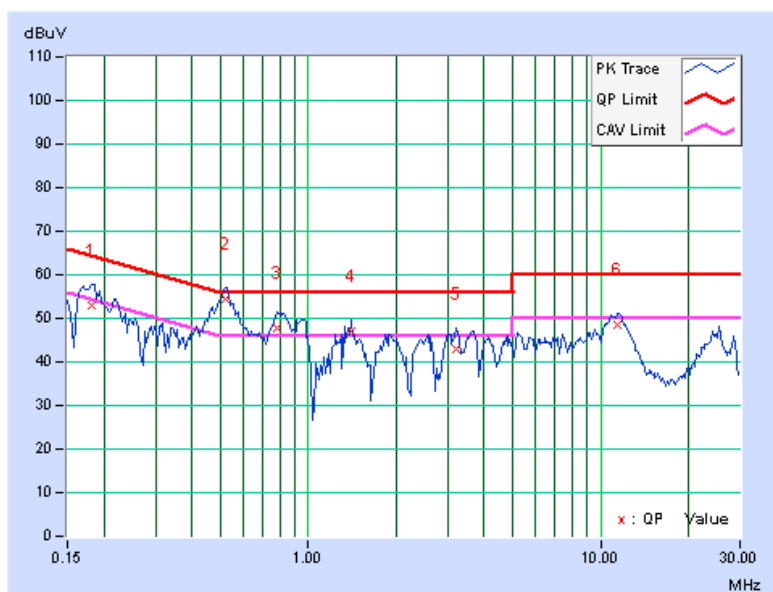

CHANNEL	Channel 252	6dB BANDWIDTH	9kHz
PHASE	Line 1	TEST MODE	B

No	Freq. [MHz]	Corr. Factor (dB)	Reading Value		Emission Level		Limit		Margin	
			[dB (uV)]		[dB (uV)]		[dB (uV)]		(dB)	
			Q.P.	AV.	Q.P.	AV.	Q.P.	AV.	Q.P.	AV.
1	0.16172	0.15	55.08	36.16	55.23	36.31	65.38	55.38	-10.15	-19.07
2	0.54063	0.17	52.31	40.85	52.48	41.02	56.00	46.00	-3.52	-4.98
3	0.72422	0.18	45.75	33.69	45.93	33.87	56.00	46.00	-10.07	-12.13
4	1.26172	0.21	44.08	35.64	44.29	35.85	56.00	46.00	-11.71	-10.15
5	1.84766	0.25	42.06	34.04	42.31	34.29	56.00	46.00	-13.69	-11.71
6	11.23047	0.45	45.33	40.43	45.78	40.88	60.00	50.00	-14.22	-9.12

REMARKS:

1. Q.P. and AV. are abbreviations of quasi-peak and average individually.
2. The emission levels of other frequencies were very low against the limit.
3. Margin value = Emission level - Limit value
4. Correction factor = Insertion loss + Cable loss
5. Emission Level = Correction Factor + Reading Value.

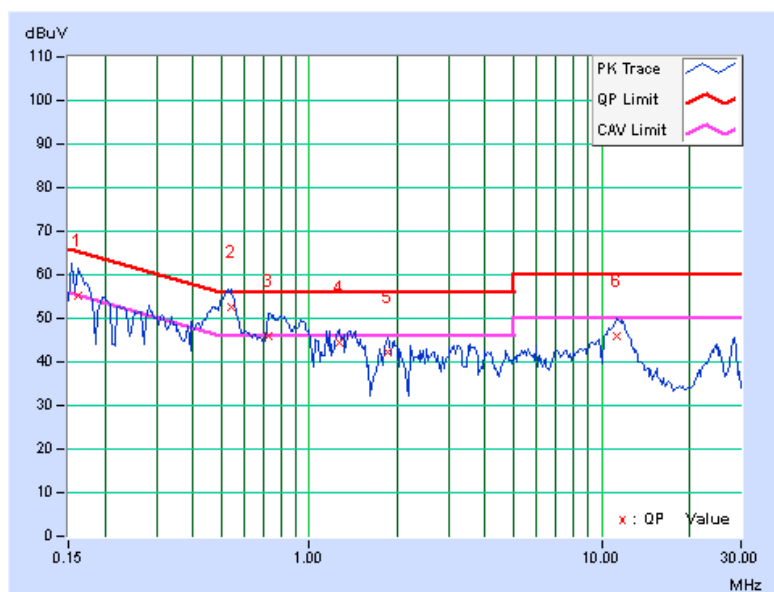

CHANNEL	Channel 252	6dB BANDWIDTH	9kHz
PHASE	Line 2	TEST MODE	B

No	Freq. [MHz]	Corr. Factor (dB)	Reading Value		Emission Level		Limit		Margin	
			[dB (uV)]		[dB (uV)]		[dB (uV)]		(dB)	
			Q.P.	AV.	Q.P.	AV.	Q.P.	AV.	Q.P.	AV.
1	0.16172	0.13	52.09	30.92	52.22	31.05	65.38	55.38	-13.15	-24.32
2	0.52109	0.17	54.42	44.13	54.59	44.30	56.00	46.00	-1.41	-1.70
3	0.72422	0.18	46.20	34.85	46.38	35.03	56.00	46.00	-9.62	-10.97
4	1.23828	0.21	45.25	35.62	45.46	35.83	56.00	46.00	-10.54	-10.17
5	3.53516	0.33	43.43	37.38	43.76	37.71	56.00	46.00	-12.24	-8.29
6	11.44531	0.51	48.20	43.53	48.71	44.04	60.00	50.00	-11.29	-5.96

REMARKS:

1. Q.P. and AV. are abbreviations of quasi-peak and average individually.
2. The emission levels of other frequencies were very low against the limit.
3. Margin value = Emission level - Limit value
4. Correction factor = Insertion loss + Cable loss
5. Emission Level = Correction Factor + Reading Value.

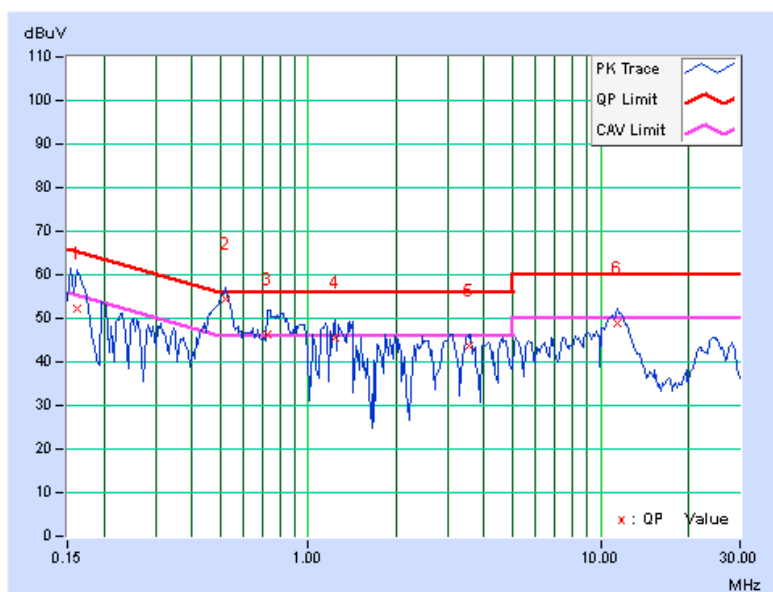

CHANNEL	Channel 1	6dB BANDWIDTH	9kHz
PHASE	Line 1	TEST MODE	C

No	Freq. [MHz]	Corr. Factor (dB)	Reading Value		Emission Level		Limit		Margin	
			[dB (uV)]		[dB (uV)]		[dB (uV)]		(dB)	
			Q.P.	AV.	Q.P.	AV.	Q.P.	AV.	Q.P.	AV.
1	0.16953	0.15	44.87	35.82	45.02	35.97	64.98	54.98	-19.96	-19.01
2	0.30114	0.16	50.97	42.22	51.13	42.38	60.21	50.21	-9.08	-7.83
3	0.33750	0.16	52.11	45.44	52.27	45.60	59.26	49.26	-6.99	-3.66
4	0.64471	0.18	46.90	35.09	47.08	35.27	56.00	46.00	-8.92	-10.73
5	0.85703	0.19	46.14	35.00	46.33	35.19	56.00	46.00	-9.67	-10.81
6	4.69531	0.35	43.66	36.06	44.01	36.41	56.00	46.00	-11.99	-9.59

REMARKS:

1. Q.P. and AV. are abbreviations of quasi-peak and average individually.
2. The emission levels of other frequencies were very low against the limit.
3. Margin value = Emission level - Limit value
4. Correction factor = Insertion loss + Cable loss
5. Emission Level = Correction Factor + Reading Value.

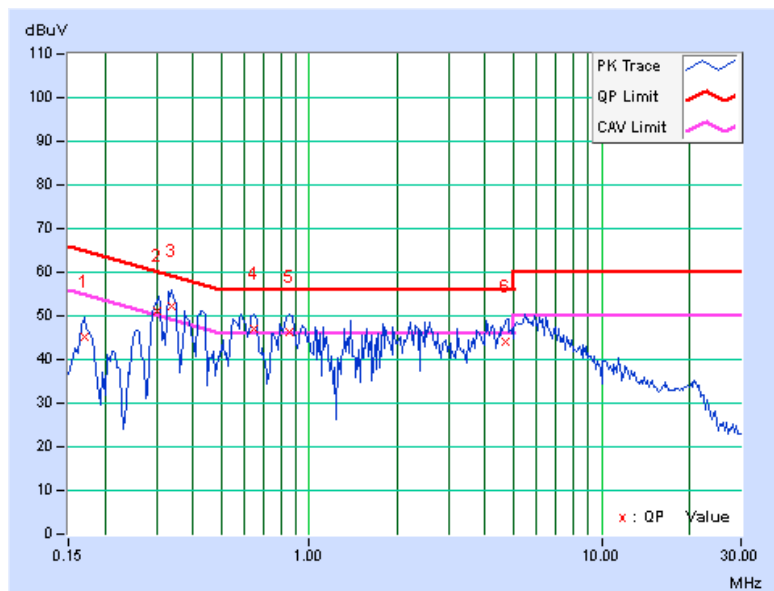

CHANNEL	Channel 1	6dB BANDWIDTH	9kHz
PHASE	Line 2	TEST MODE	C

No	Freq. [MHz]	Corr. Factor (dB)	Reading Value		Emission Level		Limit		Margin	
			[dB (uV)]		[dB (uV)]		[dB (uV)]		(dB)	
			Q.P.	AV.	Q.P.	AV.	Q.P.	AV.	Q.P.	AV.
1	0.16562	0.13	45.96	34.29	46.09	34.42	65.18	55.18	-19.08	-20.75
2	0.29608	0.15	45.54	36.05	45.69	36.20	60.35	50.35	-14.66	-14.15
3	0.32969	0.15	48.21	41.19	48.36	41.34	59.46	49.46	-11.10	-8.12
4	0.58359	0.17	44.68	35.46	44.85	35.63	56.00	46.00	-11.15	-10.37
5	0.87266	0.18	43.28	32.28	43.46	32.46	56.00	46.00	-12.54	-13.54
6	4.25391	0.36	39.69	31.77	40.05	32.13	56.00	46.00	-15.95	-13.87

REMARKS:

1. Q.P. and AV. are abbreviations of quasi-peak and average individually.
2. The emission levels of other frequencies were very low against the limit.
3. Margin value = Emission level - Limit value
4. Correction factor = Insertion loss + Cable loss
5. Emission Level = Correction Factor + Reading Value.

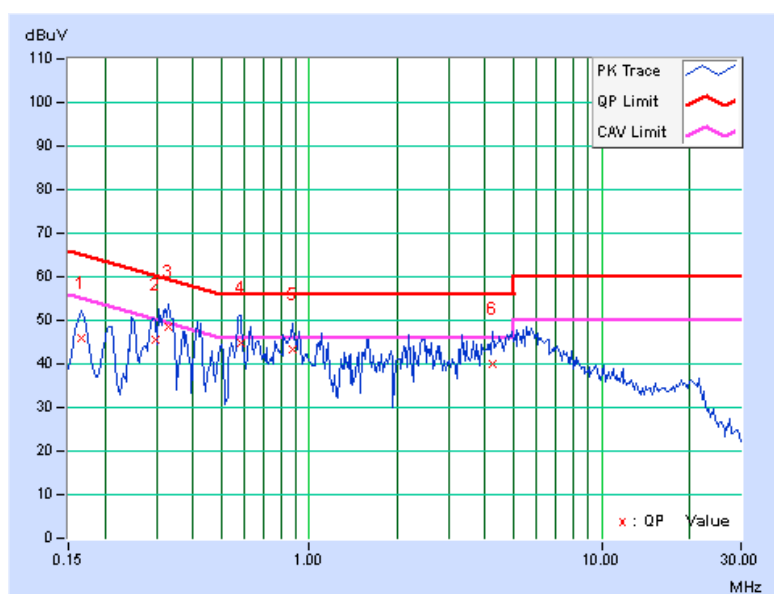

CHANNEL	Channel 126	6dB BANDWIDTH	9kHz
PHASE	Line 1	TEST MODE	C

No	Freq. [MHz]	Corr. Factor (dB)	Reading Value		Emission Level		Limit		Margin	
			[dB (uV)]		[dB (uV)]		[dB (uV)]		(dB)	
			Q.P.	AV.	Q.P.	AV.	Q.P.	AV.	Q.P.	AV.
1	0.16562	0.15	45.61	34.96	45.76	35.11	65.18	55.18	-19.42	-20.07
2	0.29724	0.16	51.07	42.89	51.23	43.05	60.32	50.32	-9.09	-7.27
3	0.32969	0.16	52.68	44.77	52.84	44.93	59.46	49.46	-6.62	-4.53
4	0.58359	0.18	48.30	39.55	48.48	39.73	56.00	46.00	-7.52	-6.27
5	0.86094	0.19	44.67	34.68	44.86	34.87	56.00	46.00	-11.14	-11.13
6	4.31641	0.34	43.69	35.36	44.03	35.70	56.00	46.00	-11.97	-10.30

REMARKS:

1. Q.P. and AV. are abbreviations of quasi-peak and average individually.
2. The emission levels of other frequencies were very low against the limit.
3. Margin value = Emission level - Limit value
4. Correction factor = Insertion loss + Cable loss
5. Emission Level = Correction Factor + Reading Value.

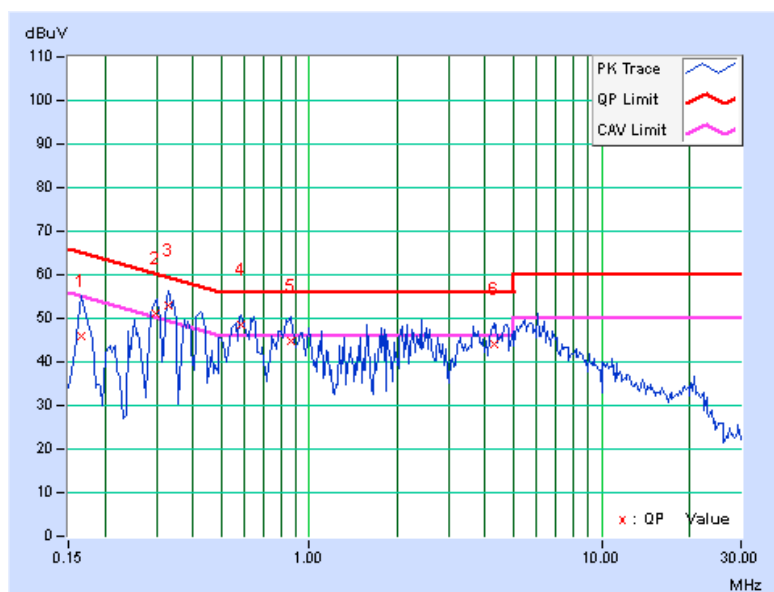

CHANNEL	Channel 126	6dB BANDWIDTH	9kHz
PHASE	Line 2	TEST MODE	C

No	Freq. [MHz]	Corr. Factor (dB)	Reading Value		Emission Level		Limit		Margin	
			[dB (uV)]		[dB (uV)]		[dB (uV)]		(dB)	
			Q.P.	AV.	Q.P.	AV.	Q.P.	AV.	Q.P.	AV.
1	0.16562	0.13	45.73	34.39	45.86	34.52	65.18	55.18	-19.31	-20.65
2	0.29063	0.15	46.15	40.22	46.30	40.37	60.51	50.51	-14.21	-10.14
3	0.32969	0.15	47.95	40.55	48.10	40.70	59.46	49.46	-11.36	-8.76
4	0.57969	0.17	44.50	35.38	44.67	35.55	56.00	46.00	-11.33	-10.45
5	0.87266	0.18	42.60	31.39	42.78	31.57	56.00	46.00	-13.22	-14.43
6	4.08984	0.35	39.26	31.45	39.61	31.80	56.00	46.00	-16.39	-14.20

REMARKS:

1. Q.P. and AV. are abbreviations of quasi-peak and average individually.
2. The emission levels of other frequencies were very low against the limit.
3. Margin value = Emission level - Limit value
4. Correction factor = Insertion loss + Cable loss
5. Emission Level = Correction Factor + Reading Value.

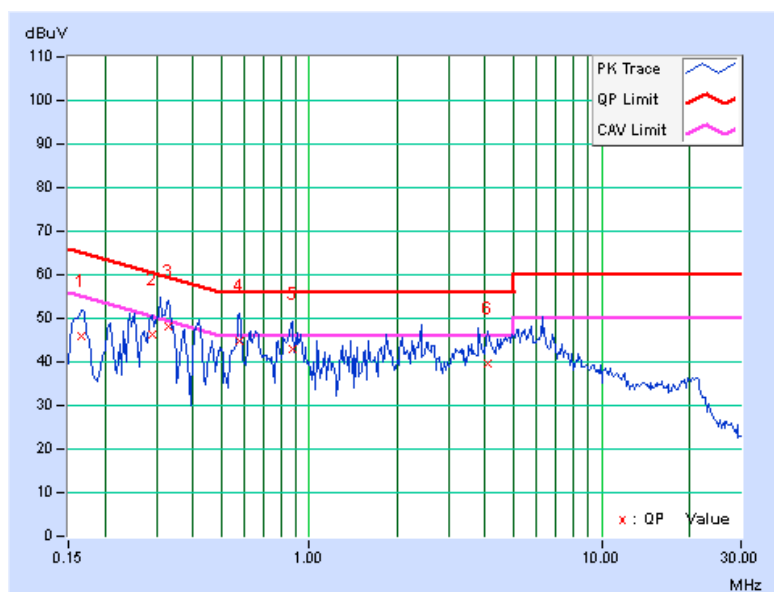

CHANNEL	Channel 252	6dB BANDWIDTH	9kHz
PHASE	Line 1	TEST MODE	C

No	Freq. [MHz]	Corr. Factor (dB)	Reading Value		Emission Level		Limit		Margin	
			[dB (uV)]		[dB (uV)]		[dB (uV)]		(dB)	
			Q.P.	AV.	Q.P.	AV.	Q.P.	AV.	Q.P.	AV.
1	0.16953	0.15	45.51	34.15	45.66	34.30	64.98	54.98	-19.32	-20.68
2	0.29344	0.16	50.81	44.45	50.97	44.61	60.43	50.43	-9.46	-5.82
3	0.33214	0.16	52.26	46.03	52.42	46.19	59.40	49.40	-6.97	-3.20
4	0.57578	0.18	49.06	39.55	49.24	39.73	56.00	46.00	-6.76	-6.27
5	0.85313	0.19	44.75	33.93	44.94	34.12	56.00	46.00	-11.06	-11.88
6	4.50391	0.35	43.72	35.68	44.07	36.03	56.00	46.00	-11.93	-9.97

REMARKS:

1. Q.P. and AV. are abbreviations of quasi-peak and average individually.
2. The emission levels of other frequencies were very low against the limit.
3. Margin value = Emission level - Limit value
4. Correction factor = Insertion loss + Cable loss
5. Emission Level = Correction Factor + Reading Value.

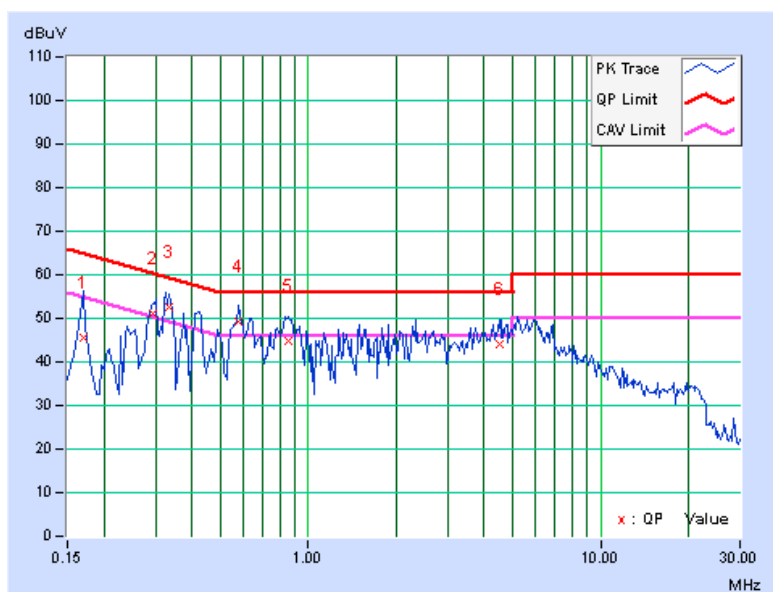

CHANNEL	Channel 252	6dB BANDWIDTH	9kHz
PHASE	Line 2	TEST MODE	C

No	Freq. [MHz]	Corr. Factor (dB)	Reading Value		Emission Level		Limit		Margin	
			[dB (uV)]		[dB (uV)]		[dB (uV)]		(dB)	
			Q.P.	AV.	Q.P.	AV.	Q.P.	AV.	Q.P.	AV.
1	0.16571	0.13	45.45	34.35	45.58	34.48	65.17	55.17	-19.59	-20.69
2	0.29453	0.15	46.33	38.10	46.48	38.25	60.40	50.40	-13.92	-12.15
3	0.33359	0.15	47.06	40.06	47.21	40.21	59.36	49.36	-12.15	-9.15
4	0.57578	0.17	44.70	35.79	44.87	35.96	56.00	46.00	-11.13	-10.04
5	0.87266	0.18	42.94	31.96	43.12	32.14	56.00	46.00	-12.88	-13.86
6	4.43359	0.36	40.10	32.64	40.46	33.00	56.00	46.00	-15.54	-13.00

REMARKS:

1. Q.P. and AV. are abbreviations of quasi-peak and average individually.
2. The emission levels of other frequencies were very low against the limit.
3. Margin value = Emission level - Limit value
4. Correction factor = Insertion loss + Cable loss
5. Emission Level = Correction Factor + Reading Value.

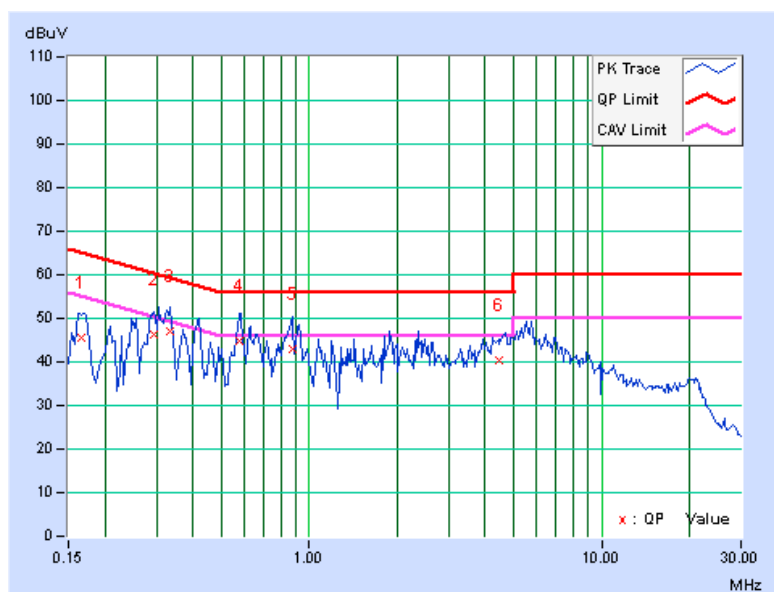



A D T

5. PHOTOGRAPHS OF THE TEST CONFIGURATION

Please refer to the attached file (Test Setup Photo).



A D T

6. INFORMATION ON THE TESTING LABORATORIES

We, Bureau Veritas Consumer Products Services (H.K.) Ltd., Taoyuan Branch, were founded in 1988 to provide our best service in EMC, Radio, Telecom and Safety consultation. Our laboratories are accredited and approved according to ISO/IEC 17025.

If you have any comments, please feel free to contact us at the following:

Linko EMC/RF Lab

Tel: 886-2-26052180

Fax: 886-2-26051924

Hsin Chu EMC/RF Lab

Tel: 886-3-5935343

Fax: 886-3-5935342

Hwa Ya EMC/RF/Safety/Telecom Lab

Tel: 886-3-3183232

Fax: 886-3-3270892

Email: service.adt@tw.bureauveritas.com

Web Site: www.bureauveritas-adt.com

The address and road map of all our labs can be found in our web site also.



A D T

7. APPENDIX A - MODIFICATIONS RECORDERS FOR ENGINEERING CHANGES TO THE EUT BY THE LAB

No any modifications are made to the EUT by the lab during the test.

--- END ---