

# FCC Radio Test Report

**FCC ID** : TTUBEOPLAYH100  
**Equipment** : Wireless Headphones  
**Brand Name** : Bang & Olufsen  
**Model Name** : Beoplay H100  
**Applicant** : Bang & Olufsen A/S  
Bang og Olufsen Allé 1, 7600 Struer, Denmark  
**Manufacturer** : Bang & Olufsen A/S  
Bang og Olufsen Allé 1, 7600 Struer, Denmark  
**Standard** : 47 CFR FCC Part 15.247

The product was received on Sep. 13, 2023, and testing was started from Sep. 19, 2023 and completed on Dec. 09, 2023. We, SPORTON INTERNATIONAL INC. Hsinhua Laboratory, would like to declare that the tested sample has been evaluated in accordance with the procedures given in ANSI C63.10-2013 and shown compliance with the applicable technical standards.

The test results in this report apply exclusively to the tested model / sample. Without written approval of SPORTON INTERNATIONAL INC. Hsinhua Laboratory, the test report shall not be reproduced except in full.



Approved by: Jackson Tsai

**SPORTON INTERNATIONAL INC. Hsinhua Laboratory**

No.52, Huaya 1st Rd., Guishan Dist., Taoyuan City 333411, Taiwan (R.O.C.)



# Table of Contents

**HISTORY OF THIS TEST REPORT .....3**

**SUMMARY OF TEST RESULT .....4**

**1 GENERAL DESCRIPTION .....5**

1.1 Information.....5

1.2 Testing Applied Standards .....7

1.3 Testing Location Information .....7

1.4 Measurement Uncertainty .....7

**2 TEST CONFIGURATION OF EUT.....8**

2.1 Test Channel Mode .....8

2.2 The Worst Case Measurement Configuration.....9

2.3 Accessories .....10

2.4 Support Equipment.....10

2.5 Test Setup Diagram .....11

**3 TRANSMITTER TEST RESULT .....13**

3.1 AC Power-line Conducted Emissions .....13

3.2 DTS Bandwidth.....15

3.3 Maximum Conducted Output Power .....16

3.4 Power Spectral Density .....18

3.5 Emissions in Non-restricted Frequency Bands .....19

3.6 Emissions in Restricted Frequency Bands.....20

**4 TEST EQUIPMENT AND CALIBRATION DATA.....24**

**APPENDIX A. TEST RESULTS OF AC POWER-LINE CONDUCTED EMISSIONS**

**APPENDIX B. TEST RESULTS OF DTS BANDWIDTH**

**APPENDIX C. TEST RESULTS OF MAXIMUM CONDUCTED OUTPUT POWER**

**APPENDIX D. TEST RESULTS OF POWER SPECTRAL DENSITY**

**APPENDIX E. TEST RESULTS OF EMISSIONS IN NON-RESTRICTED FREQUENCY BANDS**

**APPENDIX F. TEST RESULTS OF EMISSIONS IN RESTRICTED FREQUENCY BANDS**

**APPENDIX G. TEST PHOTOS**

**PHOTOGRAPHS OF EUT V01**



### History of this test report

Report No.	Version	Description	Issued Date
FR391314-01AL	01	Initial issue of report	May 08, 2024



### Summary of Test Result

Report Clause	Ref.Std. Clause	Test Items	Result (PASS/FAIL)	Remark
1.1.2	15.203	Antenna Requirement	PASS	-
3.1	15.207	AC Power-line Conducted Emissions	PASS	-
3.2	15.247(a)	DTS Bandwidth	PASS	-
3.3	15.247(b)	Maximum Conducted Output Power	PASS	-
3.4	15.247(e)	Power Spectral Density	PASS	-
3.5	15.247(d)	Emissions in Non-restricted Frequency Bands	PASS	-
3.6	15.247(d)	Emissions in Restricted Frequency Bands	PASS	-

<b>Declaration of Conformity:</b>
The test results with all measurement uncertainty excluded are presented in accordance with the regulation limits or requirements declared by manufacturers.
<b>Comments and explanations:</b>
None

Reviewed by: Ben Tseng

Report Producer: Ann Hou



# 1 General Description

## 1.1 Information

### 1.1.1 RF General Information

Frequency Range (MHz)	Bluetooth Mode	Ch. Frequency (MHz)	Channel Number
2400-2483.5	LE	2402-2480	0-39 [40]

Band	Mode	BWch (MHz)	Nant
2.4-2.4835GHz	BT-LE(1Mbps)	1.0	1TX
2.4-2.4835GHz	BT-LE(2Mbps)	2.0	1TX

Note:

- ♦ Bluetooth LE uses a GFSK (1Mbps/2Mbps) modulation.
- ♦ BWch is the nominal channel bandwidth.

### 1.1.2 Antenna Information

Ant.	Brand	Model Name	Antenna Type	Connector	Gain (dBi)
1	TOONGIN	DH14-Ant-L	FPC	N/A	1.06
2	TOONGIN	DH14-Ant-R	FPC	N/A	0.97

Note 1: The EUT has two antennas.

**For BT function:**

For IEEE 802.15.1 Bluetooth mode (1TX/1RX)

Ant. 1 and Ant. 2 could transmit/receive.



1.1.3 EUT Information

Operational Condition	
EUT Power Type	From Battery
EUT Function	<input type="checkbox"/> Point-to-multipoint <input checked="" type="checkbox"/> Point-to-point
Type of EUT	
<input checked="" type="checkbox"/>	Stand-alone
<input type="checkbox"/>	Combined (EUT where the radio part is fully integrated within another device)
	Combined Equipment - Brand Name / Model No.: ...
<input type="checkbox"/>	Plug-in radio (EUT intended for a variety of host systems)
	Host System - Brand Name / Model No.: ...
<input type="checkbox"/>	Other:

1.1.4 Mode Test Duty Cycle

Right

Mode	DC	DCF (dB)	T (s)	VBW (Hz) ≥ 1/T
BT-LE(1Mbps)	0.608	2.16	380u	3k
BT-LE(2Mbps)	0.311	5.07	194.688u	10k

Note. If DC < 0.98, the DCF was added while measuring Output power and PSD.

Left

Mode	DC	DCF (dB)	T (s)	VBW (Hz) ≥ 1/T
BT-LE(1Mbps)	0.608	2.16	380u	3k
BT-LE(2Mbps)	0.311	5.07	194.375u	10k

Note. If DC < 0.98, the DCF was added while measuring Output power and PSD.

1.1.5 Table for Permissive Change

This product is an extension of original one reported under Sporton project number: FR391314AL  
 Below is the table for the change of the product with respect to the original one.

Modifications	Performance Checking
Audio Cable is replaced.	1. After evaluation, no RF test validations are required. 2. Update Photographs of EUT.

## 1.2 Testing Applied Standards

According to the specifications of the manufacturer, the EUT must comply with the requirements of the following standards:

- ◆ 47 CFR FCC Part 15
- ◆ ANSI C63.10-2013

The following reference test guidance is not within the scope of accreditation of TAF:

- ◆ KDB 558074 D01 v05r02
- ◆ KDB 414788 D01 v01r01

## 1.3 Testing Location Information

Test Lab. : Sporton International Inc. Hsinhua Laboratory				
<input checked="" type="checkbox"/>	Hsinhua (TAF: 3785)	ADD: No.52, Huaya 1st Rd., Guishan Dist., Taoyuan City 333411, Taiwan (R.O.C.)		
		TEL: 886-3-327-3456	FAX: 886-3-327-0973	
Test site Designation No. TW3785 with FCC.				
Test Condition	Test Site No.	Test Engineer	Test Environment	Test Date
AC Conduction	CO04-HY	Daniel Lin	21.4~22.4°C / 51~53%	09/Dec/2023
RF Conducted	TH06-HY	Peng Huang	23.3~24.6°C / 52~56%	19/Sep/2023~18/Oct/2023
<input checked="" type="checkbox"/>	Wenhua 3rd. (TAF: 3785)	ADD: No. 58, Aly. 75, Ln. 564, Wenhua 3rd Rd., Guishan Dist. Taoyuan City 333, Taiwan (R.O.C.)		
		TEL: 886-3-327-0868		
Test site Designation No. TW0036 with FCC.				
Test Condition	Test Site No.	Test Engineer	Test Environment	Test Date
Radiated	03CH24-HY	Lego Lin	23.4~24.2°C / 52~55%	20/Sep/2023~09/Dec/2023

## 1.4 Measurement Uncertainty

ISO/IEC 17025 requires that an estimate of the measurement uncertainties associated with the emissions test results be included in the report. The measurement uncertainties given below are based on a 95% confidence level (based on a coverage factor (k=2))

Test Items	Uncertainty	Remark
AC Power-line Conducted Emissions	4.53 dB	Confidence levels of 95%
Bandwidth	3 MHz	Confidence levels of 95%
Maximum Conducted Output Power	2 dB	Confidence levels of 95%
Power Spectral Density	2 dB	Confidence levels of 95%
Emissions in Non-restricted Frequency Bands	0.14 dB	Confidence levels of 95%
Emissions in Restricted Frequency Bands	4.8 dB	Confidence levels of 95%
Temperature	0.41 °C	Confidence levels of 95%
Humidity	3.4 %	Confidence levels of 95%



## 2 Test Configuration of EUT

### 2.1 Test Channel Mode



Test Software Version	AB158x_Airoha_Tool_Kit(ATK)_v3.4.4
Mode	Power Setting
BT-LE(1Mbps)	-
2402MHz	40
2440MHz	40
2480MHz	40
BT-LE(2Mbps)	-
2404MHz	40
2440MHz	40
2478MHz	40



## 2.2 The Worst Case Measurement Configuration

The Worst Case Mode for Following Conformance Tests	
<b>Tests Item</b>	AC power-line conducted emissions
<b>Condition</b>	AC power-line conducted measurement for line and neutral Test Voltage: 120Vac / 60Hz
<b>Operating Mode</b>	CTX
1	USB mode
2	Adapter mode

The Worst Case Mode for Following Conformance Tests	
<b>Tests Item</b>	DTS Bandwidth Maximum Conducted Output Power Power Spectral Density Emissions in Non-restricted Frequency Bands
<b>Test Condition</b>	Conducted measurement at transmit chains

The Worst Case Mode for Following Conformance Tests			
<b>Tests Item</b>	Emissions in Restricted Frequency Bands		
<b>Test Condition</b>	Radiated measurement If EUT consist of multiple antenna assembly (multiple antenna are used in EUT regardless of spatial multiplexing MIMO configuration), the radiated test should be performed with highest antenna gain of each antenna type.		
<b>Operating Mode &lt; 1GHz</b>	CTX		
1	USB mode		
2	Adapter mode		
<b>Operating Mode &gt; 1GHz</b>	CTX		
1	Adapter mode		
<b>Orthogonal Planes of EUT</b>	<b>X Plane</b>	<b>Y Plane</b>	<b>Z Plane</b>
			
<b>Worst Planes of EUT</b>	V		

## 2.3 Accessories

Accessories				
Battery	<b>Brand Name</b>	VDL	<b>Model Name</b>	422535PF4
	<b>Power Rating</b>	3.85 Vdc, 520 mAh	<b>Type</b>	Rechargeable Li-ion Battery Pack
USB Cable	<b>Brand Name</b>	Bang & Olufsen	<b>Model Name</b>	4021XW01972ZAU
	<b>Signal Line</b>	1.25 meter, D-shielded cable, w/o ferrite core		
Audio Cable	<b>Brand Name</b>	Bang & Olufsen	<b>Model Name</b>	4021XW01971ZAS
	<b>Signal Line</b>	1.25 meter, B-shielded cable, w/o ferrite core		

Reminder: Regarding to more detail and other information, please refer to user manual.

## 2.4 Support Equipment

Support Equipment – AC Conduction					
No.	Equipment	Brand Name	Model Name	FCC ID	Remark
1	Notebook	HP	HSTNN-142C	-	-
2	Adapter for NB	HP	HSTNN-CA40	-	-
3	Adapter	Apple	A2305	-	-

Support Equipment – Conducted					
No.	Equipment	Brand Name	Model Name	FCC ID	Remark
1	Notebook	DELL	E5410	-	-
2	Adapter for NB	DELL	HA65NM130	-	-
3	Airoha dongle	Airoha	Airoha dongle	-	Provided by Customer
4	Airoha dongle to B&O dongle cable	toongin	Airoha dongle	-	Provided by Customer
5	B&O dongle	Bang & Olufsen	UART cable	-	Provided by Customer

Support Equipment – Radiated					
No.	Equipment	Brand Name	Model Name	FCC ID	Remark
1	Notebook	HP	HSTNN-142C	-	-
2	Adapter for NB	HP	HSTNN-CA40	-	-
3	Adapter	Apple	A2305	-	-

## 2.5 Test Setup Diagram

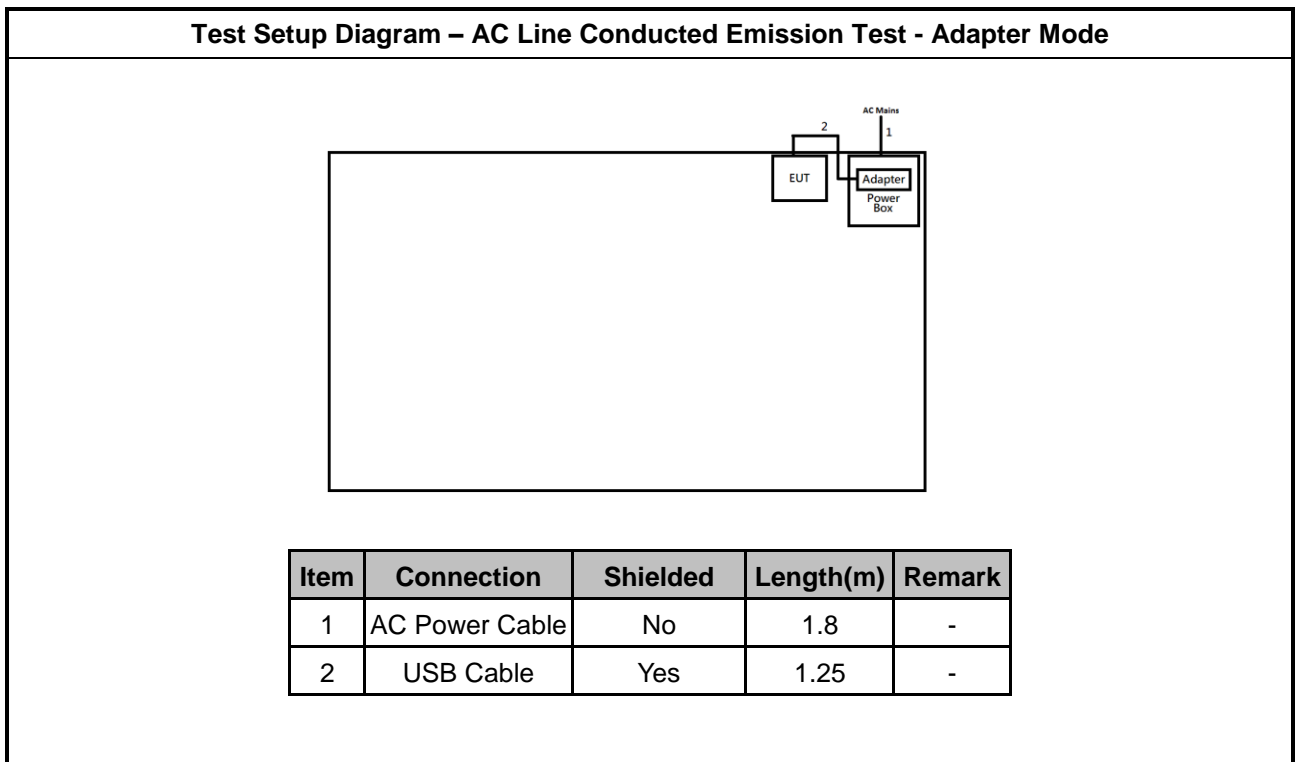
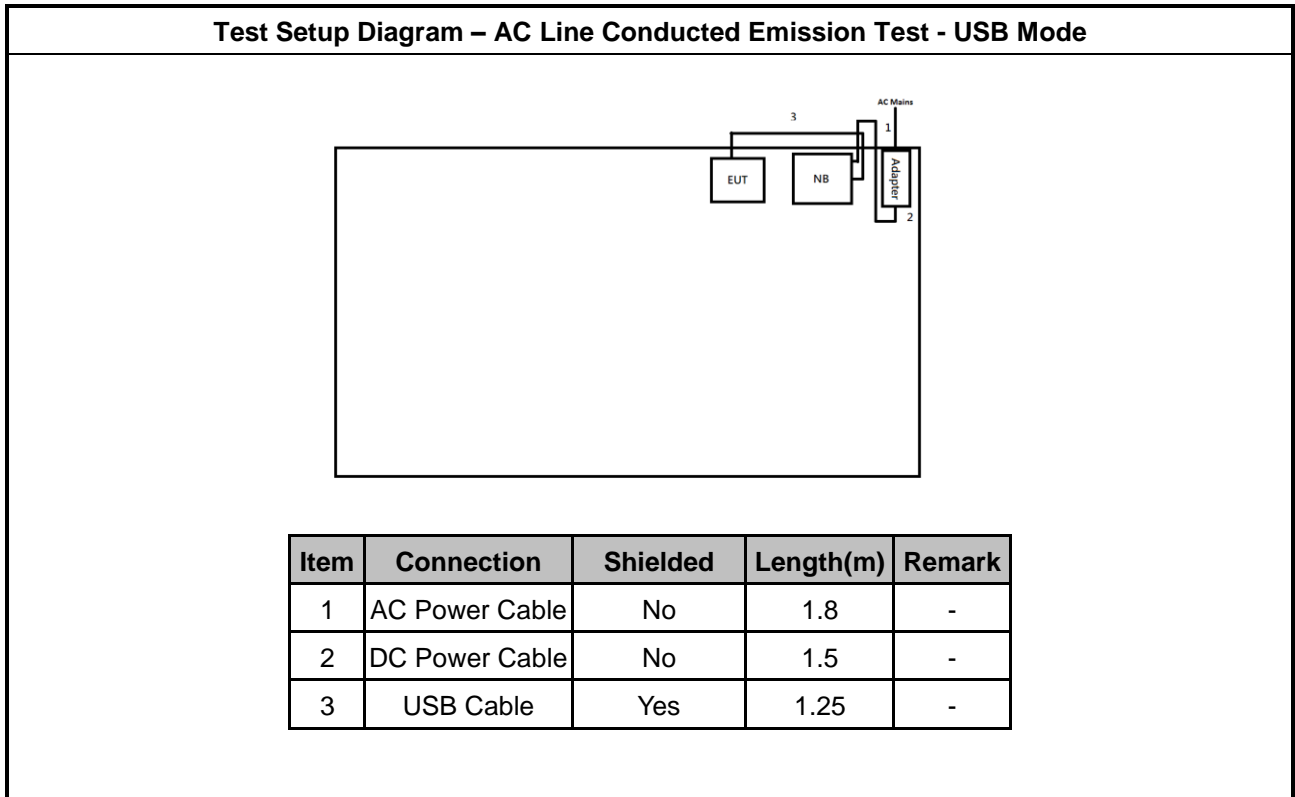

Test Setup Diagram - Radiated Test – USB Mode

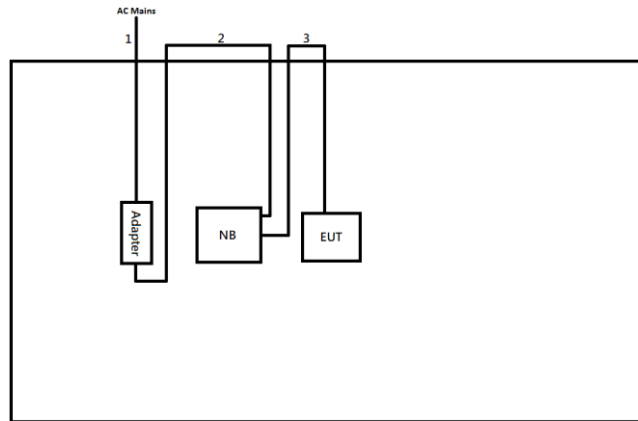

Item	Connection	Shielded	Length(m)	Remark
1	AC Power Cable	No	1.8	-
2	DC Power Cable	No	1.5	-
3	USB Cable	Yes	1.25	-

Test Setup Diagram - Radiated Test - Adapter Mode

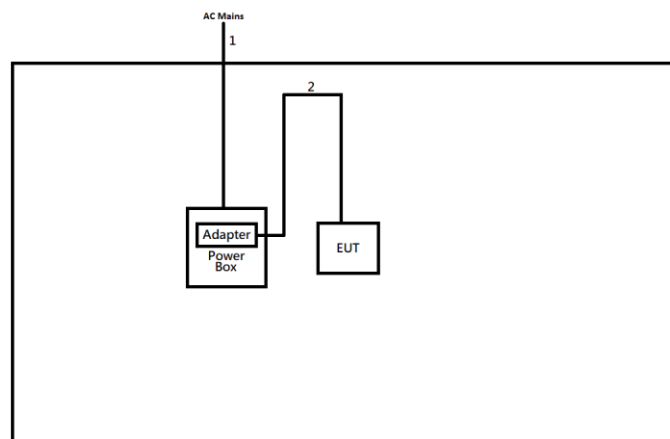

Item	Connection	Shielded	Length(m)	Remark
1	AC Power Cable	No	1.8	-
2	USB Cable	Yes	1.25	-



### 3 Transmitter Test Result

#### 3.1 AC Power-line Conducted Emissions

##### 3.1.1 AC Power-line Conducted Emissions Limit

AC Power-line Conducted Emissions Limit		
Frequency Emission (MHz)	Quasi-Peak	Average
0.15-0.5	66 - 56 *	56 - 46 *
0.5-5	56	46
5-30	60	50

Note 1: \* Decreases with the logarithm of the frequency.

##### 3.1.2 Measuring Instruments

Refer a test equipment and calibration data table in this test report.

##### 3.1.3 Test Procedures

Test Method
<ul style="list-style-type: none"> <li>Refer as ANSI C63.10-2013, clause 6.2 foray power-line conducted emissions.</li> </ul>

##### 3.1.4 Measurement Results Calculation

The measured Level is calculated using:

Corrected Reading: Raw(Read Level) +LISN(LISN Factor) + CL(Cable Loss) + AT(Attenuator).

### 3.1.5 Test Setup

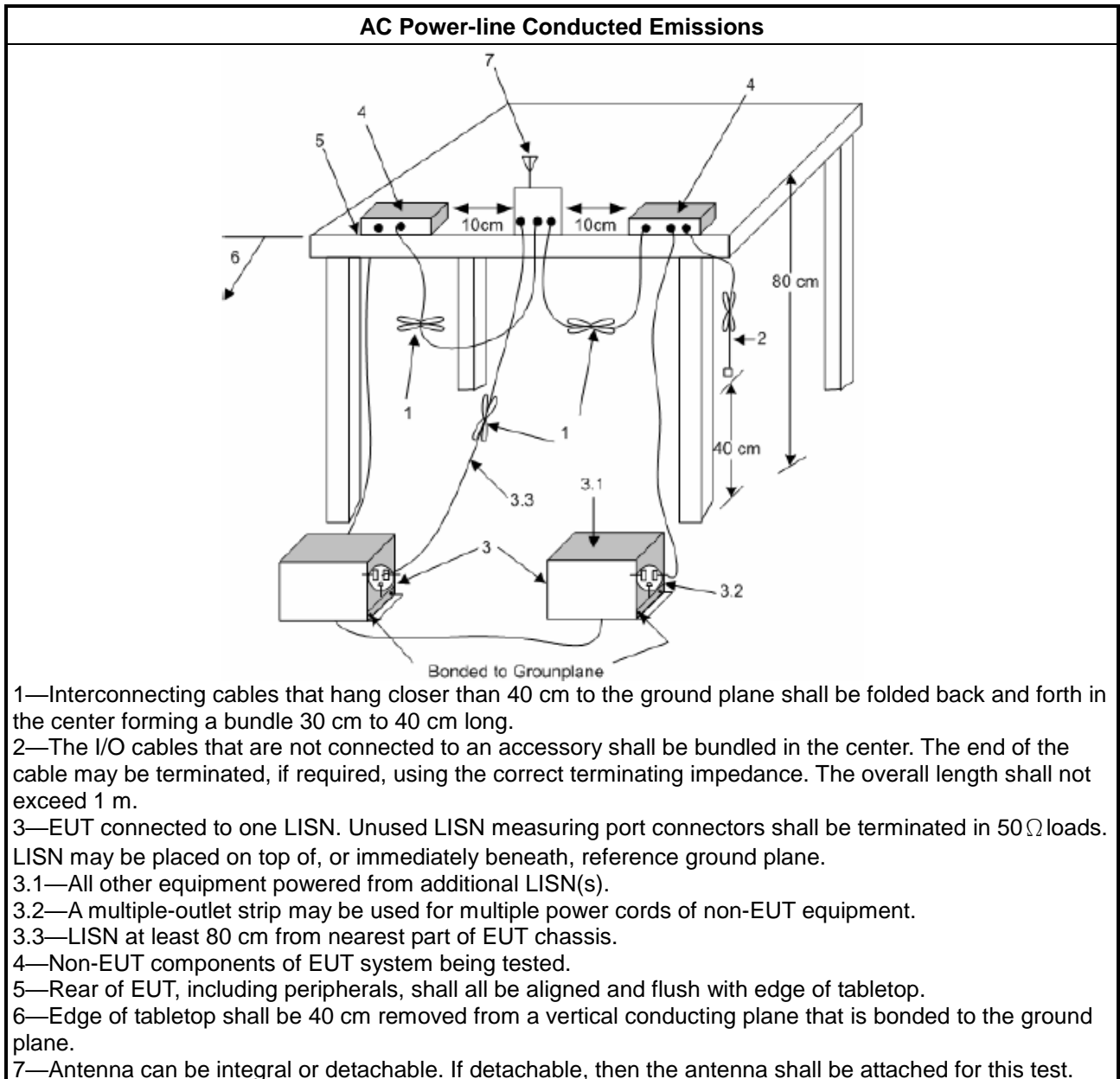

### 3.1.6 Test Result of AC Power-line Conducted Emissions

Refer as Appendix A

### 3.2 DTS Bandwidth

#### 3.2.1 6dB Bandwidth Limit

6dB Bandwidth Limit	
Systems using digital modulation techniques:	
▪	6 dB bandwidth $\geq$ 500 kHz.

#### 3.2.2 Measuring Instruments

Refer a test equipment and calibration data table in this test report.

#### 3.2.3 Test Procedures

Test Method	
▪	For the emission bandwidth shall be measured using one of the options below:
<input checked="" type="checkbox"/>	Refer as KDB 558074, clause 8.2 (11.8 of ANSI C63.10) DTS bandwidth measurement.
<input type="checkbox"/>	Refer as RSS-Gen, clause 6.7 for occupied bandwidth testing.
<input type="checkbox"/>	Refer as ANSI C63.10, clause 6.9.3 for occupied bandwidth testing.

#### 3.2.4 Test Setup

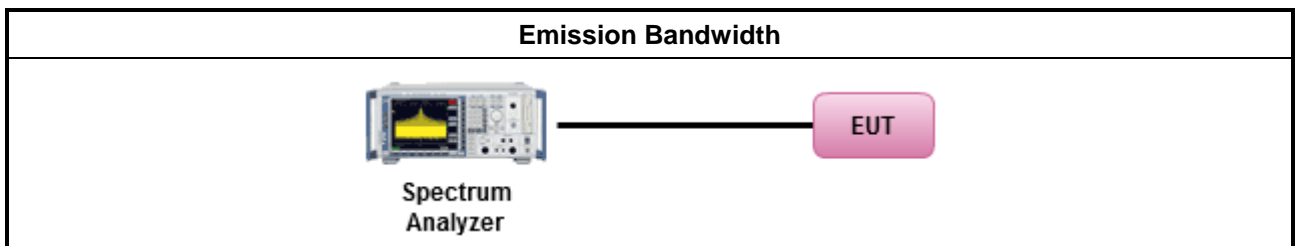

#### 3.2.5 Test Result of Emission Bandwidth

Refer as Appendix B

### 3.3 Maximum Conducted Output Power

#### 3.3.1 Maximum Conducted Output Power Limit

Maximum Conducted Output Power Limit	
	<ul style="list-style-type: none"> <li>▪ If <math>G_{TX} \leq 6</math> dBi, then <math>P_{Out} \leq 30</math> dBm (1 W)</li> </ul>
	<ul style="list-style-type: none"> <li>▪ Point-to-multipoint systems (P2M): If <math>G_{TX} &gt; 6</math> dBi, then <math>P_{Out} = 30 - (G_{TX} - 6)</math> dBm</li> </ul>
	<ul style="list-style-type: none"> <li>▪ Point-to-point systems (P2P): If <math>G_{TX} &gt; 6</math> dBi, then <math>P_{Out} = 30 - (G_{TX} - 6)/3</math> dBm</li> </ul>
	<ul style="list-style-type: none"> <li>▪ Smart antenna system (SAS):</li> </ul>
	<ul style="list-style-type: none"> <li>- Single beam: If <math>G_{TX} &gt; 6</math> dBi, then <math>P_{Out} = 30 - (G_{TX} - 6)/3</math> dBm</li> </ul>
	<ul style="list-style-type: none"> <li>- Overlap beam: If <math>G_{TX} &gt; 6</math> dBi, then <math>P_{Out} = 30 - (G_{TX} - 6)/3</math> dBm</li> </ul>
	<ul style="list-style-type: none"> <li>- Aggregate power on all beams: If <math>G_{TX} &gt; 6</math> dBi, then <math>P_{Out} = 30 - (G_{TX} - 6)/3 + 8</math> dB dBm</li> </ul>
e.i.r.p. Power Limit:	
	<ul style="list-style-type: none"> <li>▪ 2400-2483.5 MHz Band</li> </ul>
	<ul style="list-style-type: none"> <li>▪ Point-to-multipoint systems (P2M): <math>P_{eirp} \leq 36</math> dBm (4 W)</li> </ul>
	<ul style="list-style-type: none"> <li>▪ Point-to-point systems (P2P): <math>P_{eirp} \leq \text{MAX}(36, [P_{Out} + G_{TX}])</math> dBm</li> </ul>
	<ul style="list-style-type: none"> <li>▪ Smart antenna system (SAS)</li> </ul>
	<ul style="list-style-type: none"> <li>- Single beam: <math>P_{eirp} \leq \text{MAX}(36, P_{Out} + G_{TX})</math> dBm</li> </ul>
	<ul style="list-style-type: none"> <li>- Overlap beam: <math>P_{eirp} \leq \text{MAX}(36, P_{Out} + G_{TX})</math> dBm</li> </ul>
	<ul style="list-style-type: none"> <li>- Aggregate power on all beams: <math>P_{eirp} \leq \text{MAX}(36, [P_{Out} + G_{TX} + 8])</math> dBm</li> </ul>
<p><math>P_{Out}</math> = maximum peak conducted output power or maximum conducted output power in dBm,  <math>G_{TX}</math> = the maximum transmitting antenna directional gain in dBi.</p>	

#### 3.3.2 Measuring Instruments

Refer a test equipment and calibration data table in this test report.



### 3.3.3 Test Procedures

Test Method	
<ul style="list-style-type: none"> <li>▪ Maximum Peak Conducted Output Power</li> </ul>	
<input type="checkbox"/>	Refer as KDB 558074, clause 8.3.1.1 (11.9.1.1 of ANSI C63.10) RBW ≥ EBW method.
<input type="checkbox"/>	Refer as KDB 558074, clause 8.3.1.2 (11.9.1.2 of ANSI C63.10) integrated band power method.
<input type="checkbox"/>	Refer as KDB 558074, clause 8.3.1.3 (11.9.1.3 of ANSI C63.10) peak power meter.
<ul style="list-style-type: none"> <li>▪ Maximum Average Conducted Output Power</li> </ul>	
<input type="checkbox"/>	Refer as KDB 558074, clause 8.3.2.2 (11.9.2.2 of ANSI C63.10) using a spectrum analyzer.
<input checked="" type="checkbox"/>	Refer as KDB 558074, clause 8.3.2.3 (11.9.2.3 of ANSI C63.10) using a power meter.
<ul style="list-style-type: none"> <li>▪ For conducted measurement.</li> </ul>	
<ul style="list-style-type: none"> <li>▪ If the EUT supports multiple transmit chains using options given below: Refer as KDB 662911, In-band power measurements. Using the measure-and-sum approach, measured all transmit ports individually. Sum the power (in linear power units e.g., mW) of all ports for each individual sample and save them.</li> </ul>	
<ul style="list-style-type: none"> <li>▪ If multiple transmit chains, EIRP calculation could be following as methods:  <math>P_{total} = P_1 + P_2 + \dots + P_n</math>                      (calculated in linear unit [mW] and transfer to log unit [dBm])  <math>EIRP_{total} = P_{total} + DG</math> </li> </ul>	

### 3.3.4 Test Setup

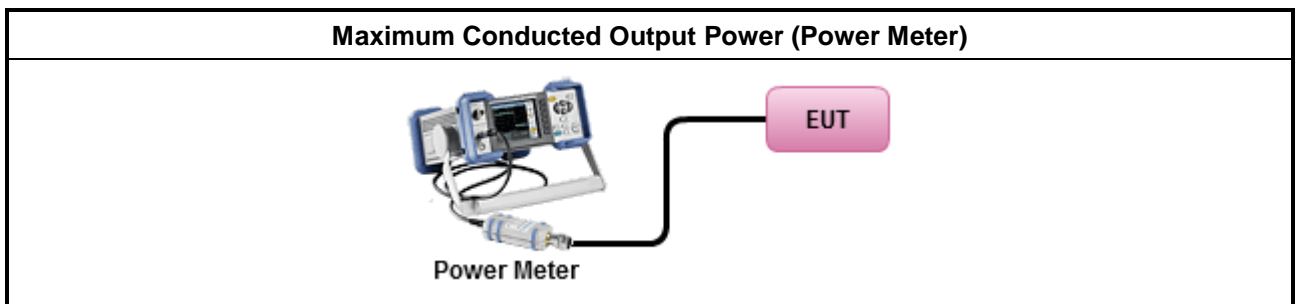

### 3.3.5 Test Result of Maximum Conducted Output Power

Refer as Appendix C

### 3.4 Power Spectral Density

#### 3.4.1 Power Spectral Density Limit

Power Spectral Density Limit
<ul style="list-style-type: none"> <li>Power Spectral Density (PSD) ≤ 8 dBm/3kHz</li> </ul>

#### 3.4.2 Measuring Instruments

Refer a test equipment and calibration data table in this test report.

#### 3.4.3 Test Procedures

Test Method	
	<ul style="list-style-type: none"> <li>Peak power spectral density procedures that the same method as used to determine the conducted output power. If maximum peak conducted output power was measured to demonstrate compliance to the output power limit, then the peak PSD procedure below (Method PKPSD) shall be used. If maximum conducted output power was measured to demonstrate compliance to the output power limit, then one of the average PSD procedures shall be used, as applicable based on the following criteria (the peak PSD procedure is also an acceptable option).</li> </ul>
<input checked="" type="checkbox"/>	Refer as KDB 558074, clause 8.4 (11.10 of ANSI C63.10) Max. PSD.
	<ul style="list-style-type: none"> <li>For conducted measurement.               <ul style="list-style-type: none"> <li>If The EUT supports multiple transmit chains using options given below:                   <ul style="list-style-type: none"> <li>Measure and sum the spectra across the outputs. Refer as KDB 662911, In-band power spectral density (PSD). Sample all transmit ports simultaneously using a spectrum analyzer for each transmit port. Where the trace bin-by-bin of each transmit port summing can be performed. (i.e., in the first spectral bin of output 1 is summed with that in the first spectral bin of output 2 and that from the first spectral bin of output 3, and so on up to the NTX output to obtain the value for the first frequency bin of the summed spectrum.). Add up the amplitude (power) values for the different transmit chains and use this as the new data trace.</li> </ul> </li> </ul> </li> </ul>

#### 3.4.4 Test Setup

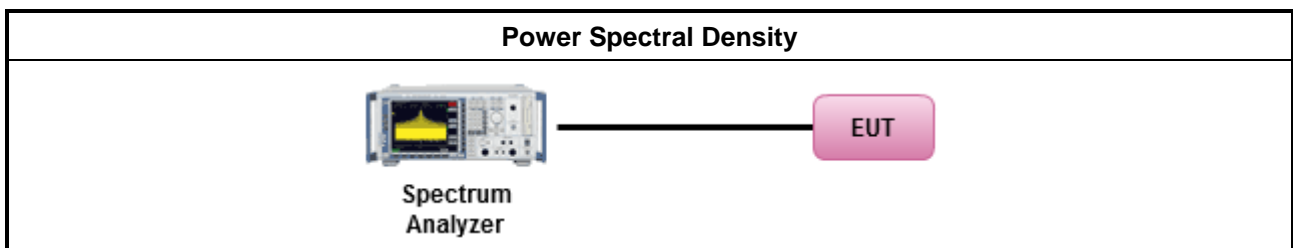

#### 3.4.5 Test Result of Power Spectral Density

Refer as Appendix D

### 3.5 Emissions in Non-restricted Frequency Bands

#### 3.5.1 Emissions in Non-restricted Frequency Bands Limit

Un-restricted Band Emissions Limit	
RF output power procedure	Limit (dB)
Peak output power procedure	20
Average output power procedure	30

Note 1: If the peak output power procedure is used to measure the fundamental emission power to demonstrate compliance to requirements, then the peak conducted output power measured within any 100 kHz outside the authorized frequency band shall be attenuated by at least 20 dB relative to the maximum measured in-band peak level.

Note 2: If the average output power procedure is used to measure the fundamental emission power to demonstrate compliance to requirements, then the power in any 100 kHz outside of the authorized frequency band shall be attenuated by at least 30 dB relative to the maximum measured in-band average level.

#### 3.5.2 Measuring Instruments

Refer a test equipment and calibration data table in this test report.

#### 3.5.3 Test Procedures

Test Method
<ul style="list-style-type: none"> <li>Refer as KDB 558074, clause 8.5 (11.11 of ANSI C63.10) for non-restricted frequency bands.</li> </ul>

#### 3.5.4 Test Setup

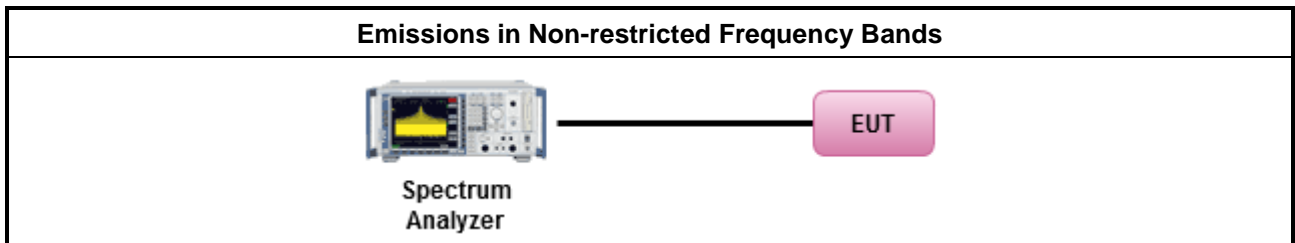

#### 3.5.5 Test Result of Emissions in Non-restricted Frequency Bands

Refer as Appendix E

### 3.6 Emissions in Restricted Frequency Bands

#### 3.6.1 Emissions in Restricted Frequency Bands Limit

Restricted Band Emissions Limit			
Frequency Range (MHz)	Field Strength (uV/m)	Field Strength (dBuV/m)	Measure Distance (m)
0.009~0.490	2400/F(kHz)	48.5 - 13.8	300
0.490~1.705	24000/F(kHz)	33.8 - 23	30
1.705~30.0	30	29	30
30~88	100	40	3
88~216	150	43.5	3
216~960	200	46	3
Above 960	500	54	3

Note 1: Test distance for frequencies at or above 30 MHz, measurements may be performed at a distance other than the limit distance provided they are not performed in the near field and the emissions to be measured can be detected by the measurement equipment. When performing measurements at a distance other than that specified, the results shall be extrapolated to the specified distance using an extrapolation factor of 20 dB/decade (inverse of linear distance for field-strength measurements, inverse of linear distance-squared for power-density measurements).

Note 2: Test distance for frequencies at below 30 MHz, measurements may be performed at a distance closer than the EUT limit distance; however, an attempt should be made to avoid making measurements in the near field. When performing measurements below 30 MHz at a closer distance than the limit distance, the results shall be extrapolated to the specified distance by either making measurements at a minimum of two or more distances on at least one radial to determine the proper extrapolation factor or by using the square of an inverse linear distance extrapolation factor (40 dB / decade). The test report shall specify the extrapolation method used to determine compliance of the EUT.

Note 3: Using the distance of 1m during the test for above 18 GHz, and the test value to correct for the distance factor at 3m.

#### 3.6.2 Measuring Instruments

Refer a test equipment and calibration data table in this test report.

**3.6.3 Test Procedures**

<b>Test Method</b>	
	<ul style="list-style-type: none"> <li>▪ The average emission levels shall be measured in [duty cycle ≥ 98 or duty factor].</li> </ul>
	<ul style="list-style-type: none"> <li>▪ Refer as ANSI C63.10, clause 6.10.3 band-edge testing shall be performed at the lowest frequency channel and highest frequency channel within the allowed operating band.</li> </ul>
	<ul style="list-style-type: none"> <li>▪ For the transmitter unwanted emissions shall be measured using following options below:</li> </ul>
	<ul style="list-style-type: none"> <li>▪ Refer as KDB 558074, clause 8.6 (11.12 of ANSI C63.10) for restricted frequency bands.</li> </ul>
	<ul style="list-style-type: none"> <li>▪ For the transmitter band-edge emissions shall be measured using following options below:</li> </ul>
	<ul style="list-style-type: none"> <li>▪ Refer as KDB 558074 clause 8.7.1, When the performing peak or average radiated measurements, emissions within 2 MHz of the authorized band edge may be measured using the marker-delta method described below.</li> </ul>
	<ul style="list-style-type: none"> <li>▪ Refer as KDB 558074, clause 8.7.2 (6.10.6 of ANSI C63.10) for marker-delta method for band-edge measurements.</li> </ul>
	<ul style="list-style-type: none"> <li>▪ Refer as KDB 558074, clause 8.7.3 for narrower resolution bandwidth (100kHz) using the band power and summing the spectral levels.</li> </ul>
	<ul style="list-style-type: none"> <li>▪ Use the following spectrum analyzer settings:</li> </ul>
	<ul style="list-style-type: none"> <li>▪ Set RBW=100 kHz for f &lt; 1 GHz; VBW=3 * RBW; Sweep = auto; Detector function = peak; Trace = max hold.</li> </ul>
	<ul style="list-style-type: none"> <li>▪ Set RBW = 1 MHz, VBW= 3MHz for f ≥ 1 GHz for peak measurement. For average measurement, refer as 1.1.4.</li> </ul>
	<ul style="list-style-type: none"> <li>▪ KDB 414788 Open-Field Test Sites and Chamber Correlation Justification.</li> </ul>
	<ul style="list-style-type: none"> <li>▪ Based on FCC 15.31(f)(2): measurements may be performed at a distance closer than that specified in regulations; however, an attempt should be made to avoid making measurements in the near field.</li> </ul>
	<ul style="list-style-type: none"> <li>▪ Open-field site and chamber correlation testing had been performed and chamber measured test result is the worst case test result.</li> </ul>

**3.6.4 Measurement Results Calculation**

The measured Level is calculated using:

Corrected Reading: Raw(Read Level) + AF(Antenna Factor) + CL(Cable Loss) - PA(Preamplifier Factor)

### 3.6.5 Test Setup

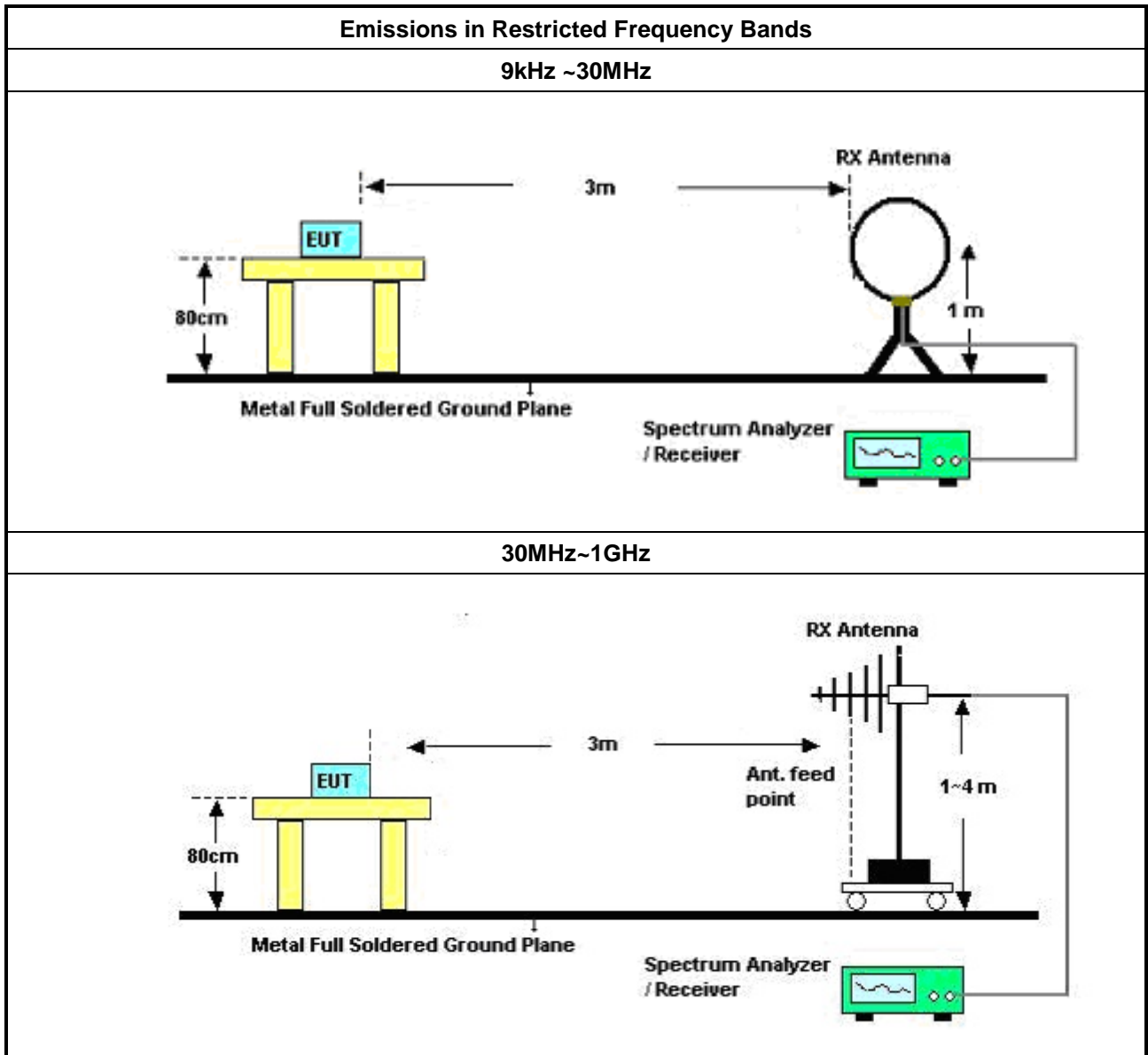

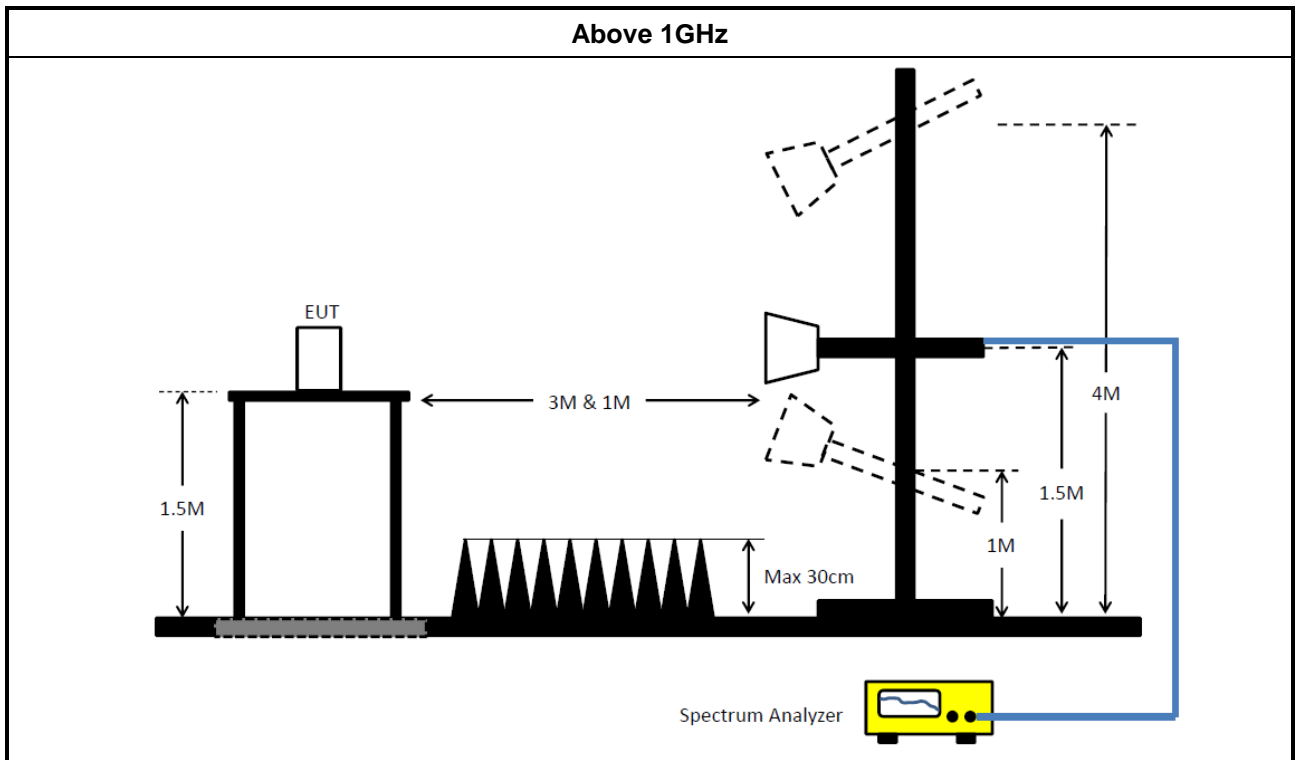

### 3.6.6 Test Result of Emissions in Restricted Frequency Bands (Below 30MHz)

The amplitude of spurious emissions which are attenuated by more than 20dB below the permissible value has no need to be reported.

### 3.6.7 Test Result of Emissions in Restricted Frequency Bands

Refer as Appendix F

## 4 Test Equipment and Calibration Data

### Instrument for AC Conduction

Instrument	Manufacturer /Brand	Model No.	Serial No.	Spec.	Calibration Date	Calibration Due Date
EMI Test Receiver	R&S	ESR	102051	9kHz ~ 3.6GHz	16/May/2023	15/May/2024
Two-Line V-Network	R&S	ENV 216	101295	9kHz ~ 30MHz	31/Jan/2023	30/Jan/2024
RF Cable 5m	TITAN	TITAN	CO04-cable-01	9 kHz~200MHz	28/Feb/2023	27/Feb/2024
Impuls Begrenzer Pulse Limiter	SCHWARZBECK	VTSD 9561-F	9561-F041	9kHz ~ 30MHz	18/Oct/2023	17/Oct/2024
Software	Sporton	SENSE-EMI	V5.11.3	-	NCR	NCR

NCR: No Calibration Required

### Instrument for Conducted Test

Instrument	Manufacturer /Brand	Model No.	Serial No.	Spec.	Calibration Date	Calibration Due Date
Signal Analyzer	ROHDE&SCHWARZ	FSV3044	101410	10Hz~44GHz	02/Nov/2022	01/Nov/2023
SMB100A Signal Generator	R&S	SMB100A	181147	100kHz~40GHz	21/Oct/2022	20/Oct/2023
Pulse Sensor	Anritsu	MA2411B	1027452	300MHz~40GHz	29/Mar/2023	28/Mar/2024
Power Meter	Anritsu	ML2495A	1124009	300MHz~40GHz	29/Mar/2023	28/Mar/2024
SENSE-15247_FS	Sporton	V5.11.12	N/A	N/A	N/A	N/A





Instrument for Radiated Test

Instrument	Manufacturer /Brand	Model No.	Serial No.	Spec.	Calibration Date	Calibration Due Date
3m Semi Anechoic Chamber	TDK	SAC-3M	03CH24-HY	30MHz~1GHz 3m	17/Aug/2023	16/Aug/2024
3m Semi Anechoic Chamber	TDK	SAC-3M	03CH24-HY	1GHz~18GHz 3m	03/Aug/2023	02/Aug/2024
Signal Analyzer	ROHDE&SCHWARZ	FSV3044	101345	10Hz~44GHz	10/Aug/2023	09/Aug/2024
Double Ridged Guide Horn Antenna	SCHWARZBECK	BBHA 9120 D	02744	1GHz~18GHz	17/Aug/2023	16/Aug/2024
Bilog Antenna & 6dB Attenuator	TESEQ / Woken	CBL 6112D / 00800N1D01N-06	35376 / 02	30MHz~1GHz	17/Apr/2023	16/Apr/2024
Pre-Amplifier	Aglient	8447D	2944A06292	30MHz~1GHz	26/Apr/2023	25/Apr/2024
Amplifier	EM	EM01G18G	060870	1GHz ~18GHz	10/Aug/2023	09/Aug/2024
RF Cable	HUBER+SUHNER	SUOFLEX 102	CB001	1GHz~40GHz	21/Jul/2023	20/Jul/2024
RF Cable	HUBER+SUHNER	SUOFLEX 104	CB002	30MHz~40GHz	21/Jul/2023	20/Jul/2024
Amplifier	EM	EM18G40G	060604	18GHz ~ 40GHz	16/Mar/2023	15/Mar/2024
Broadband Horn Antenna	SCHWARZBECK	BBHA 9170	01248	18GHz~40GHz	21/Aug/2023	20/Aug/2024
EMI Test Receiver	ROHDE & SCHWARZ	ESR	102318	9kHz~3.6GHz	29/Dec/2022	28/Dec/2023
Loop Antenna	TESEQ	HLA 6120	31244	9kHz~30MHz	23/Mar/2023	22/Mar/2024
SENSE-15247-FS	Sporton	V5.11.15	NA	NA	NA	NA



**Summary**

Mode	Result	Type	Freq (Hz)	Level (dBuV)	Limit (dBuV)	Margin (dB)	Condition
Mode 1	Pass	AV	3.686M	20.34	46.00	-25.66	Line
Mode 2	Pass	AV	487.008k	35.71	46.21	-10.50	Neutral



Result

Mode	Result	Type	Freq (Hz)	Level (dBuV)	Limit (dBuV)	Margin (dB)	Condition
Mode 1	Pass	QP	174.571k	20.86	64.74	-43.88	Line
Mode 1	Pass	AV	174.571k	15.73	54.74	-39.01	Line
Mode 1	Pass	QP	260.222k	19.92	61.43	-41.51	Line
Mode 1	Pass	AV	260.222k	14.32	51.43	-37.11	Line
Mode 1	Pass	QP	456.875k	14.85	56.75	-41.90	Line
Mode 1	Pass	AV	456.875k	12.54	46.75	-34.21	Line
Mode 1	Pass	QP	1.848M	15.06	56.00	-40.94	Line
Mode 1	Pass	AV	1.848M	13.40	46.00	-32.60	Line
Mode 1	Pass	QP	3.686M	24.94	56.00	-31.06	Line
Mode 1	Pass	AV	3.686M	20.34	46.00	-25.66	Line
Mode 1	Pass	QP	5.65M	16.11	60.00	-43.89	Line
Mode 1	Pass	AV	5.65M	14.92	50.00	-35.08	Line
Mode 1	Pass	QP	153.024k	21.92	65.83	-43.91	Neutral
Mode 1	Pass	AV	153.024k	17.80	55.83	-38.03	Neutral
Mode 1	Pass	QP	244.12k	19.53	61.95	-42.42	Neutral
Mode 1	Pass	AV	244.12k	14.73	51.95	-37.22	Neutral
Mode 1	Pass	QP	324.114k	16.65	59.59	-42.94	Neutral
Mode 1	Pass	AV	324.114k	13.16	49.59	-36.43	Neutral
Mode 1	Pass	QP	1.833M	16.16	56.00	-39.84	Neutral
Mode 1	Pass	AV	1.833M	13.95	46.00	-32.05	Neutral
Mode 1	Pass	QP	3.671M	22.61	56.00	-33.39	Neutral
Mode 1	Pass	AV	3.671M	19.65	46.00	-26.35	Neutral
Mode 1	Pass	QP	7.442M	15.25	60.00	-44.75	Neutral
Mode 1	Pass	AV	7.442M	14.54	50.00	-35.46	Neutral
Mode 2	Pass	QP	151.202k	48.25	65.92	-17.67	Line
Mode 2	Pass	AV	151.202k	38.18	55.92	-17.74	Line
Mode 2	Pass	QP	177.381k	42.60	64.60	-22.00	Line
Mode 2	Pass	AV	177.381k	33.62	54.60	-20.98	Line
Mode 2	Pass	QP	196.781k	39.44	63.74	-24.30	Line
Mode 2	Pass	AV	196.781k	27.49	53.74	-26.25	Line
Mode 2	Pass	QP	483.136k	40.06	56.29	-16.23	Line
Mode 2	Pass	AV	483.136k	34.97	46.29	-11.32	Line
Mode 2	Pass	QP	2.832M	30.48	56.00	-25.52	Line
Mode 2	Pass	AV	2.832M	25.11	46.00	-20.89	Line
Mode 2	Pass	QP	7.412M	28.68	60.00	-31.32	Line
Mode 2	Pass	AV	7.412M	24.21	50.00	-25.79	Line
Mode 2	Pass	QP	151.807k	49.21	65.90	-16.69	Neutral
Mode 2	Pass	AV	151.807k	38.03	55.90	-17.87	Neutral
Mode 2	Pass	QP	186.83k	40.17	64.18	-24.01	Neutral
Mode 2	Pass	AV	186.83k	29.38	54.18	-24.80	Neutral
Mode 2	Pass	QP	201.551k	38.77	63.55	-24.78	Neutral
Mode 2	Pass	AV	201.551k	27.05	53.55	-26.50	Neutral
Mode 2	Pass	QP	487.008k	40.84	56.21	-15.37	Neutral
Mode 2	Pass	AV	487.008k	35.71	46.21	-10.50	Neutral
Mode 2	Pass	QP	2.615M	30.25	56.00	-25.75	Neutral
Mode 2	Pass	AV	2.615M	25.78	46.00	-20.22	Neutral
Mode 2	Pass	QP	7.037M	29.32	60.00	-30.68	Neutral
Mode 2	Pass	AV	7.037M	24.55	50.00	-25.45	Neutral

Conducted Emissions at Powerline\_Mode 1

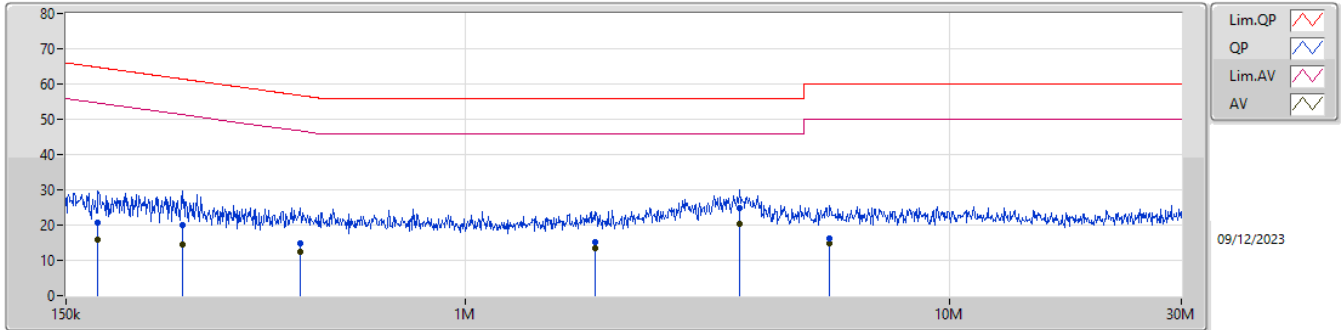

Type	Freq (Hz)	Level (dBuV)	Limit (dBuV)	Margin (dB)	Factor (dB)	Condition	Comment	Raw (dBuV)	LISN (dB)	CL (dB)	AT (dB)
QP	174.571k	20.86	64.74	-43.88	19.34	Line	-	1.52	9.59	0.03	9.72
AV	174.571k	15.73	54.74	-39.01	19.34	Line	-	-3.61	9.59	0.03	9.72
QP	260.222k	19.92	61.43	-41.51	19.33	Line	-	0.59	9.59	0.03	9.71
AV	260.222k	14.32	51.43	-37.11	19.33	Line	-	-5.01	9.59	0.03	9.71
QP	456.875k	14.85	56.75	-41.90	19.41	Line	-	-4.56	9.60	0.04	9.77
AV	456.875k	12.54	46.75	-34.21	19.41	Line	-	-6.87	9.60	0.04	9.77
QP	1.848M	15.06	56.00	-40.94	19.52	Line	-	-4.46	9.64	0.08	9.80
AV	1.848M	13.40	46.00	-32.60	19.52	Line	-	-6.12	9.64	0.08	9.80
QP	3.686M	24.94	56.00	-31.06	19.58	Line	-	5.36	9.67	0.12	9.79
AV	3.686M	20.34	46.00	-25.66	19.58	Line	-	0.76	9.67	0.12	9.79
QP	5.65M	16.11	60.00	-43.89	19.63	Line	-	-3.52	9.69	0.15	9.79
AV	5.65M	14.92	50.00	-35.08	19.63	Line	-	-4.71	9.69	0.15	9.79

Conducted Emissions at Powerline\_Mode 1

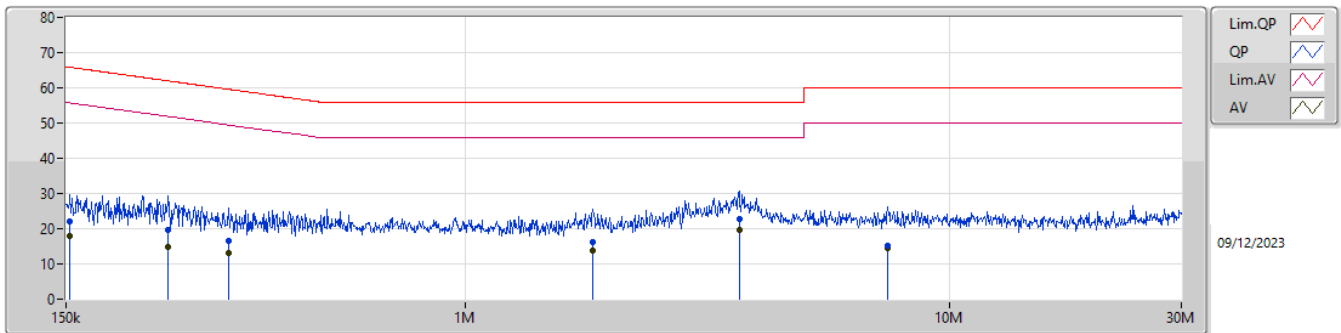

Type	Freq (Hz)	Level (dBuV)	Limit (dBuV)	Margin (dB)	Factor (dB)	Condition	Comment	Raw (dBuV)	LISN (dB)	CL (dB)	AT (dB)
QP	153.024k	21.92	65.83	-43.91	19.38	Neutral	-	2.54	9.60	0.03	9.75
AV	153.024k	17.80	55.83	-38.03	19.38	Neutral	-	-1.58	9.60	0.03	9.75
QP	244.12k	19.53	61.95	-42.42	19.33	Neutral	-	0.20	9.60	0.03	9.70
AV	244.12k	14.73	51.95	-37.22	19.33	Neutral	-	-4.60	9.60	0.03	9.70
QP	324.114k	16.65	59.59	-42.94	19.38	Neutral	-	-2.73	9.60	0.04	9.74
AV	324.114k	13.16	49.59	-36.43	19.38	Neutral	-	-6.22	9.60	0.04	9.74
QP	1.833M	16.16	56.00	-39.84	19.50	Neutral	-	-3.34	9.62	0.08	9.80
AV	1.833M	13.95	46.00	-32.05	19.50	Neutral	-	-5.55	9.62	0.08	9.80
QP	3.671M	22.61	56.00	-33.39	19.55	Neutral	-	3.06	9.64	0.12	9.79
AV	3.671M	19.65	46.00	-26.35	19.55	Neutral	-	0.10	9.64	0.12	9.79
QP	7.442M	15.25	60.00	-44.75	19.63	Neutral	-	-4.38	9.68	0.16	9.79
AV	7.442M	14.54	50.00	-35.46	19.63	Neutral	-	-5.09	9.68	0.16	9.79

Conducted Emissions at Powerline\_Mode 2

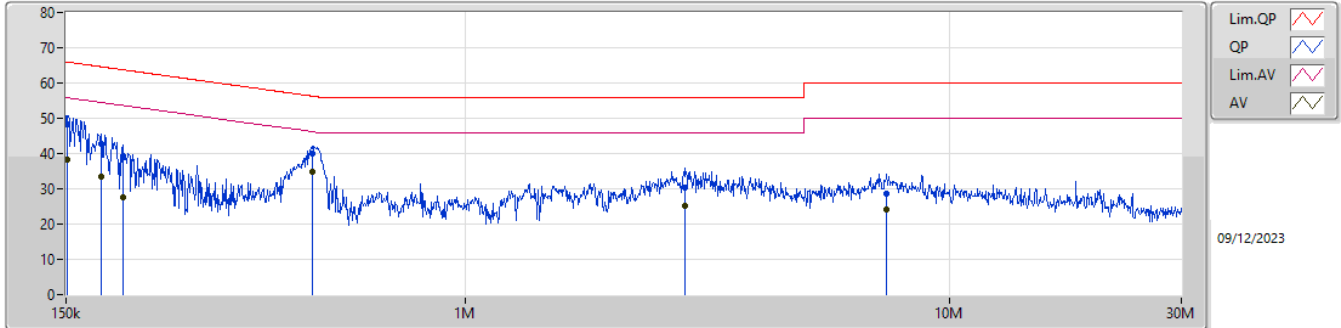

Type	Freq (Hz)	Level (dBuV)	Limit (dBuV)	Margin (dB)	Factor (dB)	Condition	Comment	Raw (dBuV)	LISN (dB)	CL (dB)	AT (dB)
QP	151.202k	48.25	65.92	-17.67	19.38	Line	-	28.87	9.59	0.03	9.76
AV	151.202k	38.18	55.92	-17.74	19.38	Line	-	18.80	9.59	0.03	9.76
QP	177.381k	42.60	64.60	-22.00	19.33	Line	-	23.27	9.59	0.03	9.71
AV	177.381k	33.62	54.60	-20.98	19.33	Line	-	14.29	9.59	0.03	9.71
QP	196.781k	39.44	63.74	-24.30	19.30	Line	-	20.14	9.59	0.03	9.68
AV	196.781k	27.49	53.74	-26.25	19.30	Line	-	8.19	9.59	0.03	9.68
QP	483.136k	40.06	56.29	-16.23	19.41	Line	-	20.65	9.60	0.04	9.77
AV	483.136k	34.97	46.29	-11.32	19.41	Line	-	15.56	9.60	0.04	9.77
QP	2.832M	30.48	56.00	-25.52	19.56	Line	-	10.92	9.66	0.11	9.79
AV	2.832M	25.11	46.00	-20.89	19.56	Line	-	5.55	9.66	0.11	9.79
QP	7.412M	28.68	60.00	-31.32	19.66	Line	-	9.02	9.71	0.16	9.79
AV	7.412M	24.21	50.00	-25.79	19.66	Line	-	4.55	9.71	0.16	9.79

Conducted Emissions at Powerline\_Mode 2



Type	Freq (Hz)	Level (dBuV)	Limit (dBuV)	Margin (dB)	Factor (dB)	Condition	Comment	Raw (dBuV)	LISN (dB)	CL (dB)	AT (dB)
QP	151.807k	49.21	65.90	-16.69	19.39	Neutral	-	29.82	9.60	0.03	9.76
AV	151.807k	38.03	55.90	-17.87	19.39	Neutral	-	18.64	9.60	0.03	9.76
QP	186.83k	40.17	64.18	-24.01	19.33	Neutral	-	20.84	9.60	0.03	9.70
AV	186.83k	29.38	54.18	-24.80	19.33	Neutral	-	10.05	9.60	0.03	9.70
QP	201.551k	38.77	63.55	-24.78	19.31	Neutral	-	19.46	9.60	0.03	9.68
AV	201.551k	27.05	53.55	-26.50	19.31	Neutral	-	7.74	9.60	0.03	9.68
QP	487.008k	40.84	56.21	-15.37	19.41	Neutral	-	21.43	9.60	0.04	9.77
AV	487.008k	35.71	46.21	-10.50	19.41	Neutral	-	16.30	9.60	0.04	9.77
QP	2.615M	30.25	56.00	-25.75	19.53	Neutral	-	10.72	9.63	0.10	9.80
AV	2.615M	25.78	46.00	-20.22	19.53	Neutral	-	6.25	9.63	0.10	9.80
QP	7.037M	29.32	60.00	-30.68	19.63	Neutral	-	9.69	9.68	0.16	9.79
AV	7.037M	24.55	50.00	-25.45	19.63	Neutral	-	4.92	9.68	0.16	9.79



**Summary**

Mode	Result	Type	Freq (Hz)	Level (dBuV)	Limit (dBuV)	Margin (dB)	Condition
Mode 1	Pass	AV	3.671M	19.68	46.00	-26.32	Neutral
Mode 2	Pass	AV	485.068k	35.49	46.25	-10.76	Neutral



Result

Mode	Result	Type	Freq (Hz)	Level (dBuV)	Limit (dBuV)	Margin (dB)	Condition
Mode 1	Pass	QP	157.361k	21.54	65.60	-44.06	Line
Mode 1	Pass	AV	157.361k	16.52	55.60	-39.08	Line
Mode 1	Pass	QP	252.043k	19.72	61.70	-41.98	Line
Mode 1	Pass	AV	252.043k	14.55	51.70	-37.15	Line
Mode 1	Pass	QP	359.562k	16.29	58.73	-42.44	Line
Mode 1	Pass	AV	359.562k	12.88	48.73	-35.85	Line
Mode 1	Pass	QP	1.84M	16.25	56.00	-39.75	Line
Mode 1	Pass	AV	1.84M	14.21	46.00	-31.79	Line
Mode 1	Pass	QP	3.671M	24.08	56.00	-31.92	Line
Mode 1	Pass	AV	3.671M	19.65	46.00	-26.35	Line
Mode 1	Pass	QP	11.453M	15.84	60.00	-44.16	Line
Mode 1	Pass	AV	11.453M	14.53	50.00	-35.47	Line
Mode 1	Pass	QP	150.6k	21.55	65.96	-44.41	Neutral
Mode 1	Pass	AV	150.6k	18.48	55.96	-37.48	Neutral
Mode 1	Pass	QP	215.704k	20.75	62.98	-42.23	Neutral
Mode 1	Pass	AV	215.704k	15.32	52.98	-37.66	Neutral
Mode 1	Pass	QP	363.895k	16.27	58.64	-42.37	Neutral
Mode 1	Pass	AV	363.895k	12.75	48.64	-35.89	Neutral
Mode 1	Pass	QP	1.733M	16.59	56.00	-39.41	Neutral
Mode 1	Pass	AV	1.733M	14.19	46.00	-31.81	Neutral
Mode 1	Pass	QP	3.671M	24.45	56.00	-31.55	Neutral
Mode 1	Pass	AV	3.671M	19.68	46.00	-26.32	Neutral
Mode 1	Pass	QP	6.095M	15.60	60.00	-44.40	Neutral
Mode 1	Pass	AV	6.095M	14.69	50.00	-35.31	Neutral
Mode 2	Pass	QP	154.251k	48.22	65.77	-17.55	Line
Mode 2	Pass	AV	154.251k	38.12	55.77	-17.65	Line
Mode 2	Pass	QP	176.674k	43.52	64.64	-21.12	Line
Mode 2	Pass	AV	176.674k	34.15	54.64	-20.49	Line
Mode 2	Pass	QP	203.98k	38.62	63.44	-24.82	Line
Mode 2	Pass	AV	203.98k	25.81	53.44	-27.63	Line
Mode 2	Pass	QP	485.068k	40.10	56.25	-16.15	Line
Mode 2	Pass	AV	485.068k	35.16	46.25	-11.09	Line
Mode 2	Pass	QP	3.067M	29.62	56.00	-26.38	Line
Mode 2	Pass	AV	3.067M	23.73	46.00	-22.27	Line
Mode 2	Pass	QP	7.208M	28.35	60.00	-31.65	Line
Mode 2	Pass	AV	7.208M	23.80	50.00	-26.20	Line
Mode 2	Pass	QP	150.6k	48.83	65.96	-17.13	Neutral
Mode 2	Pass	AV	150.6k	38.06	55.96	-17.90	Neutral
Mode 2	Pass	QP	180.236k	43.03	64.47	-21.44	Neutral
Mode 2	Pass	AV	180.236k	33.08	54.47	-21.39	Neutral
Mode 2	Pass	QP	219.176k	37.16	62.85	-25.69	Neutral
Mode 2	Pass	AV	219.176k	25.59	52.85	-27.26	Neutral
Mode 2	Pass	QP	485.068k	40.64	56.25	-15.61	Neutral
Mode 2	Pass	AV	485.068k	35.49	46.25	-10.76	Neutral
Mode 2	Pass	QP	1.061M	25.88	56.00	-30.12	Neutral
Mode 2	Pass	AV	1.061M	21.69	46.00	-24.31	Neutral
Mode 2	Pass	QP	7.15M	29.35	60.00	-30.65	Neutral
Mode 2	Pass	AV	7.15M	24.61	50.00	-25.39	Neutral

Conducted Emissions at Powerline\_Mode 1

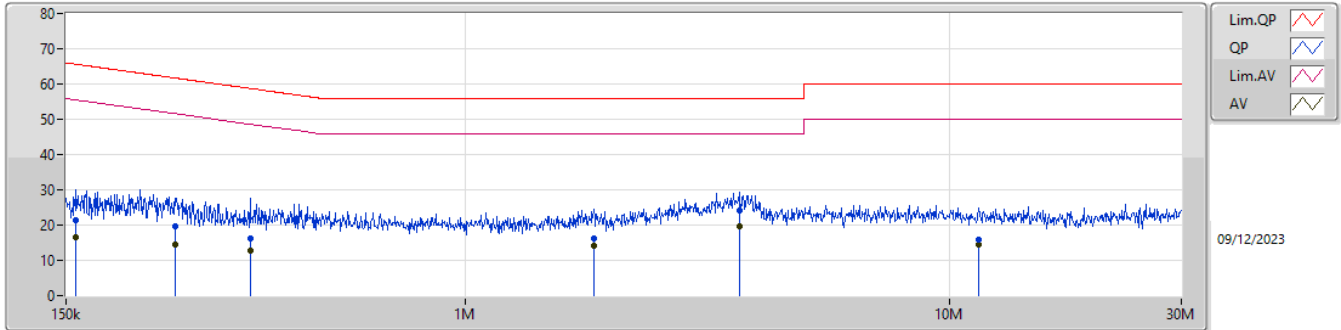

Type	Freq (Hz)	Level (dBuV)	Limit (dBuV)	Margin (dB)	Factor (dB)	Condition	Comment	Raw (dBuV)	LISN (dB)	CL (dB)	AT (dB)
QP	157.361k	21.54	65.60	-44.06	19.37	Line	-	2.17	9.59	0.03	9.75
AV	157.361k	16.52	55.60	-39.08	19.37	Line	-	-2.85	9.59	0.03	9.75
QP	252.043k	19.72	61.70	-41.98	19.33	Line	-	0.39	9.59	0.03	9.71
AV	252.043k	14.55	51.70	-37.15	19.33	Line	-	-4.78	9.59	0.03	9.71
QP	359.562k	16.29	58.73	-42.44	19.39	Line	-	-3.10	9.60	0.04	9.75
AV	359.562k	12.88	48.73	-35.85	19.39	Line	-	-6.51	9.60	0.04	9.75
QP	1.84M	16.25	56.00	-39.75	19.52	Line	-	-3.27	9.64	0.08	9.80
AV	1.84M	14.21	46.00	-31.79	19.52	Line	-	-5.31	9.64	0.08	9.80
QP	3.671M	24.08	56.00	-31.92	19.58	Line	-	4.50	9.67	0.12	9.79
AV	3.671M	19.65	46.00	-26.35	19.58	Line	-	0.07	9.67	0.12	9.79
QP	11.453M	15.84	60.00	-44.16	19.72	Line	-	-3.88	9.72	0.20	9.80
AV	11.453M	14.53	50.00	-35.47	19.72	Line	-	-5.19	9.72	0.20	9.80

Conducted Emissions at Powerline\_Mode 1

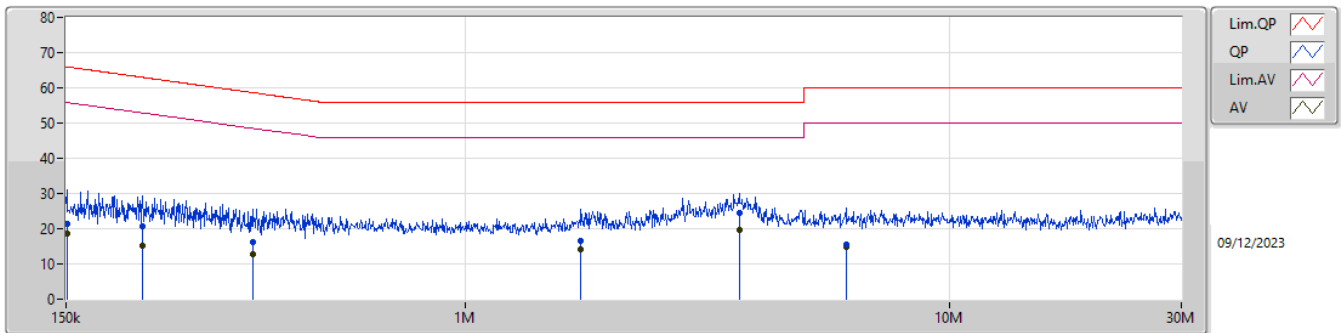

Type	Freq (Hz)	Level (dBuV)	Limit (dBuV)	Margin (dB)	Factor (dB)	Condition	Comment	Raw (dBuV)	LISN (dB)	CL (dB)	AT (dB)
QP	150.6k	21.55	65.96	-44.41	19.39	Neutral	-	2.16	9.60	0.03	9.76
AV	150.6k	18.48	55.96	-37.48	19.39	Neutral	-	-0.91	9.60	0.03	9.76
QP	215.704k	20.75	62.98	-42.23	19.32	Neutral	-	1.43	9.60	0.03	9.69
AV	215.704k	15.32	52.98	-37.66	19.32	Neutral	-	-4.00	9.60	0.03	9.69
QP	363.895k	16.27	58.64	-42.37	19.39	Neutral	-	-3.12	9.60	0.04	9.75
AV	363.895k	12.75	48.64	-35.89	19.39	Neutral	-	-6.64	9.60	0.04	9.75
QP	1.733M	16.59	56.00	-39.41	19.49	Neutral	-	-2.90	9.62	0.07	9.80
AV	1.733M	14.19	46.00	-31.81	19.49	Neutral	-	-5.30	9.62	0.07	9.80
QP	3.671M	24.45	56.00	-31.55	19.55	Neutral	-	4.90	9.64	0.12	9.79
AV	3.671M	19.68	46.00	-26.32	19.55	Neutral	-	0.13	9.64	0.12	9.79
QP	6.095M	15.60	60.00	-44.40	19.61	Neutral	-	-4.01	9.67	0.15	9.79
AV	6.095M	14.69	50.00	-35.31	19.61	Neutral	-	-4.92	9.67	0.15	9.79



Conducted Emissions at Powerline\_Mode 2

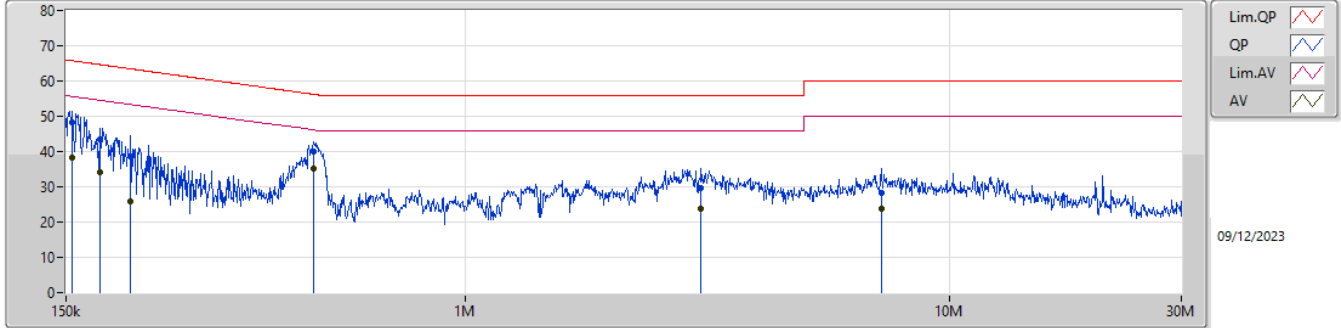

Type	Freq (Hz)	Level (dBuV)	Limit (dBuV)	Margin (dB)	Factor (dB)	Condition	Comment	Raw (dBuV)	LISN (dB)	CL (dB)	AT (dB)
QP	154.251k	48.22	65.77	-17.55	19.37	Line	-	28.85	9.59	0.03	9.75
AV	154.251k	38.12	55.77	-17.65	19.37	Line	-	18.75	9.59	0.03	9.75
QP	176.674k	43.52	64.64	-21.12	19.33	Line	-	24.19	9.59	0.03	9.71
AV	176.674k	34.15	54.64	-20.49	19.33	Line	-	14.82	9.59	0.03	9.71
QP	203.98k	38.62	63.44	-24.82	19.30	Line	-	19.32	9.59	0.03	9.68
AV	203.98k	25.81	53.44	-27.63	19.30	Line	-	6.51	9.59	0.03	9.68
QP	485.068k	40.10	56.25	-16.15	19.41	Line	-	20.69	9.60	0.04	9.77
AV	485.068k	35.16	46.25	-11.09	19.41	Line	-	15.75	9.60	0.04	9.77
QP	3.067M	29.62	56.00	-26.38	19.56	Line	-	10.06	9.66	0.11	9.79
AV	3.067M	23.73	46.00	-22.27	19.56	Line	-	4.17	9.66	0.11	9.79
QP	7.208M	28.35	60.00	-31.65	19.66	Line	-	8.69	9.71	0.16	9.79
AV	7.208M	23.80	50.00	-26.20	19.66	Line	-	4.14	9.71	0.16	9.79

Conducted Emissions at Powerline\_Mode 2

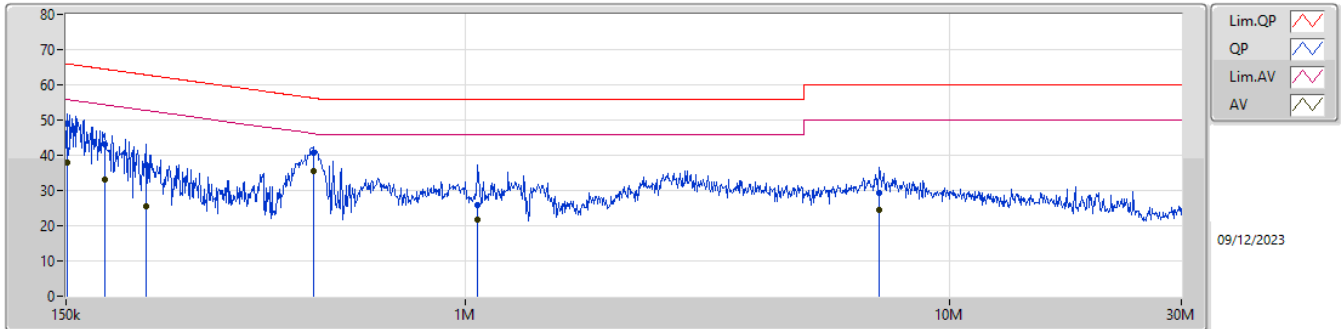

Type	Freq (Hz)	Level (dBuV)	Limit (dBuV)	Margin (dB)	Factor (dB)	Condition	Comment	Raw (dBuV)	LISN (dB)	CL (dB)	AT (dB)
QP	150.6k	48.83	65.96	-17.13	19.39	Neutral	-	29.44	9.60	0.03	9.76
AV	150.6k	38.06	55.96	-17.90	19.39	Neutral	-	18.67	9.60	0.03	9.76
QP	180.236k	43.03	64.47	-21.44	19.34	Neutral	-	23.69	9.60	0.03	9.71
AV	180.236k	33.08	54.47	-21.39	19.34	Neutral	-	13.74	9.60	0.03	9.71
QP	219.176k	37.16	62.85	-25.69	19.32	Neutral	-	17.84	9.60	0.03	9.69
AV	219.176k	25.59	52.85	-27.26	19.32	Neutral	-	6.27	9.60	0.03	9.69
QP	485.068k	40.64	56.25	-15.61	19.41	Neutral	-	21.23	9.60	0.04	9.77
AV	485.068k	35.49	46.25	-10.76	19.41	Neutral	-	16.08	9.60	0.04	9.77
QP	1.061M	25.88	56.00	-30.12	19.46	Neutral	-	6.42	9.61	0.05	9.80
AV	1.061M	21.69	46.00	-24.31	19.46	Neutral	-	2.23	9.61	0.05	9.80
QP	7.15M	29.35	60.00	-30.65	19.63	Neutral	-	9.72	9.68	0.16	9.79
AV	7.15M	24.61	50.00	-25.39	19.63	Neutral	-	4.98	9.68	0.16	9.79



**Summary**

Mode	Max-N dB (Hz)	Max-OBW (Hz)	ITU-Code	Min-N dB (Hz)	Min-OBW (Hz)
2.4-2.4835GHz	-	-	-	-	-
BT-LE(1Mbps)	693.75k	1.041M	1M04F1D	567.5k	1.025M
BT-LE(2Mbps)	1.265M	2.068M	2M07F1D	712.5k	2.028M

Max-N dB = Maximum 6dB down bandwidth; Max-OBW = Maximum 99% occupied bandwidth;  
Min-N dB = Minimum 6dB down bandwidth; Min-OBW = Minimum 99% occupied bandwidth



Result

Mode	Result	Limit (Hz)	Port 1-N dB (Hz)	Port 1-OBW (Hz)
BT-LE(1Mbps)	-	-	-	-
2402MHz	Pass	500k	678.75k	1.041M
2440MHz	Pass	500k	567.5k	1.025M
2480MHz	Pass	500k	693.75k	1.04M
BT-LE(2Mbps)	-	-	-	-
2404MHz	Pass	500k	712.5k	2.051M
2440MHz	Pass	500k	1.265M	2.028M
2478MHz	Pass	500k	992.5k	2.068M

Port X-N dB = Port X 6dB down bandwidth;  
Port X-OBW = Port X 99% occupied bandwidth

2.4-2.4835GHz\_BT-LE(1Mbps)

EBW-DTS

2402MHz

18/10/2023

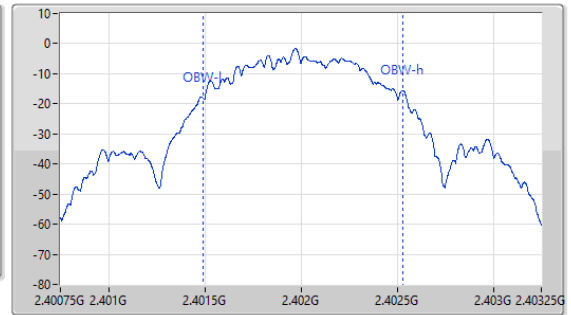
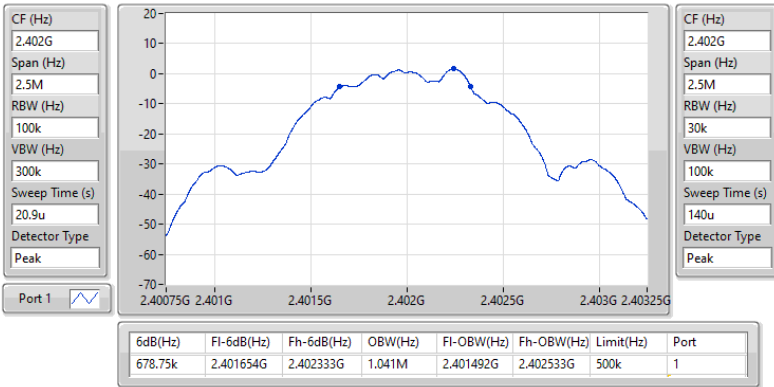

2.4-2.4835GHz\_BT-LE(1Mbps)

EBW-DTS

2440MHz

18/10/2023

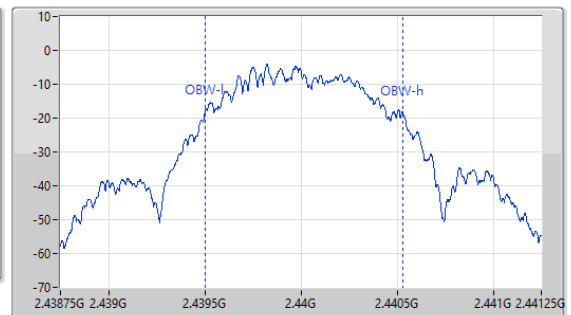
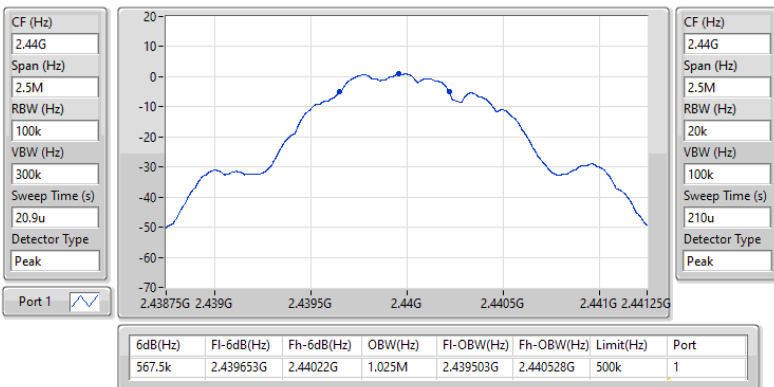

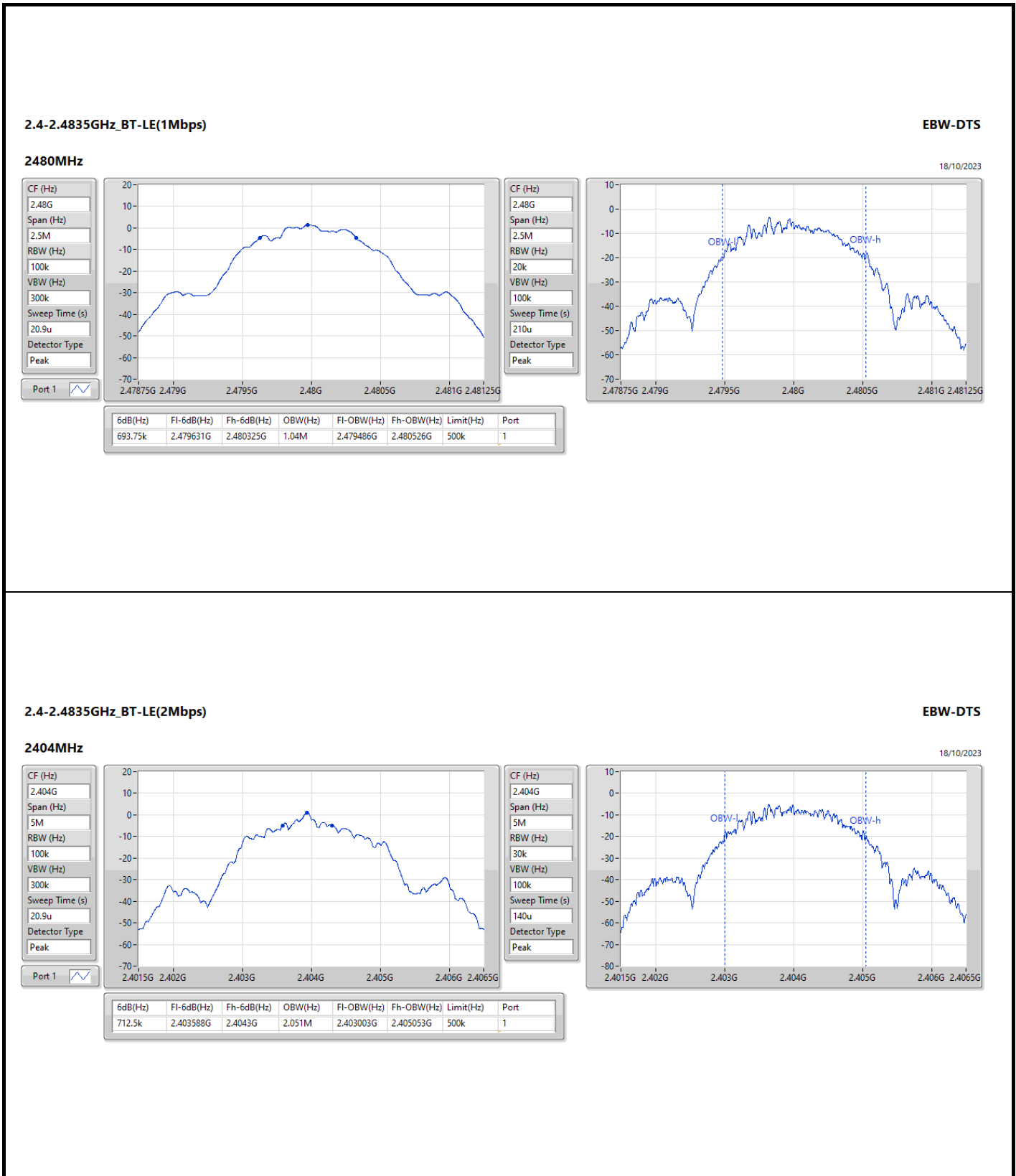

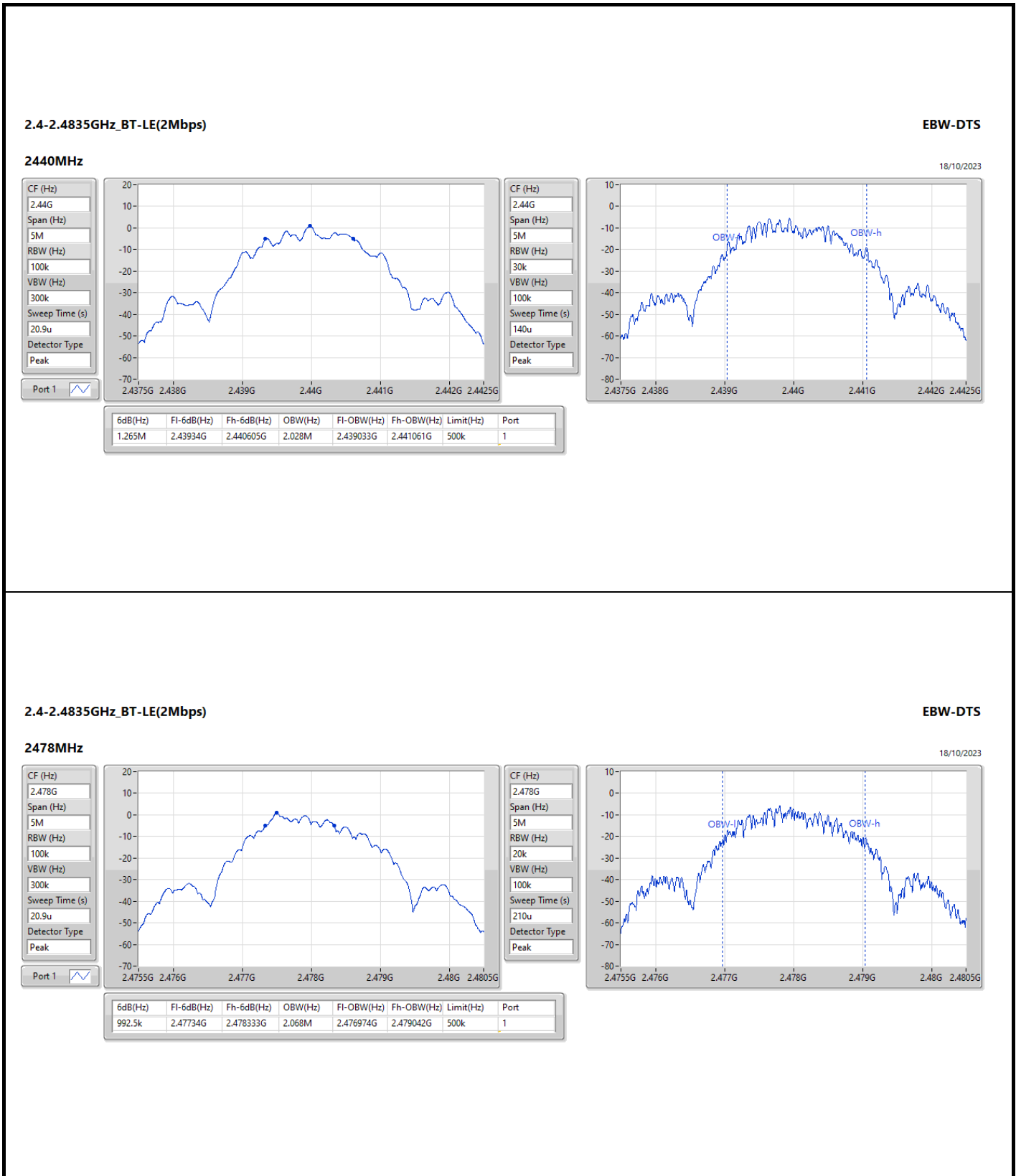



Summary

Mode	Max-N dB (Hz)	Max-OBW (Hz)	ITU-Code	Min-N dB (Hz)	Min-OBW (Hz)
2.4-2.4835GHz	-	-	-	-	-
BT-LE(1Mbps)	701.25k	1.034M	1M03F1D	691.25k	1.033M
BT-LE(2Mbps)	1.263M	2.058M	2M06F1D	1.238M	2.046M

Max-N dB = Maximum 6dB down bandwidth; Max-OBW = Maximum 99% occupied bandwidth;  
Min-N dB = Minimum 6dB down bandwidth; Min-OBW = Minimum 99% occupied bandwidth



Result

Mode	Result	Limit (Hz)	Port 1-N dB (Hz)	Port 1-OBW (Hz)
BT-LE(1Mbps)	-	-	-	-
2402MHz	Pass	500k	691.25k	1.033M
2440MHz	Pass	500k	696.25k	1.033M
2480MHz	Pass	500k	701.25k	1.034M
BT-LE(2Mbps)	-	-	-	-
2404MHz	Pass	500k	1.238M	2.058M
2440MHz	Pass	500k	1.263M	2.058M
2478MHz	Pass	500k	1.253M	2.046M

Port X-N dB = Port X 6dB down bandwidth;  
Port X-OBW = Port X 99% occupied bandwidth







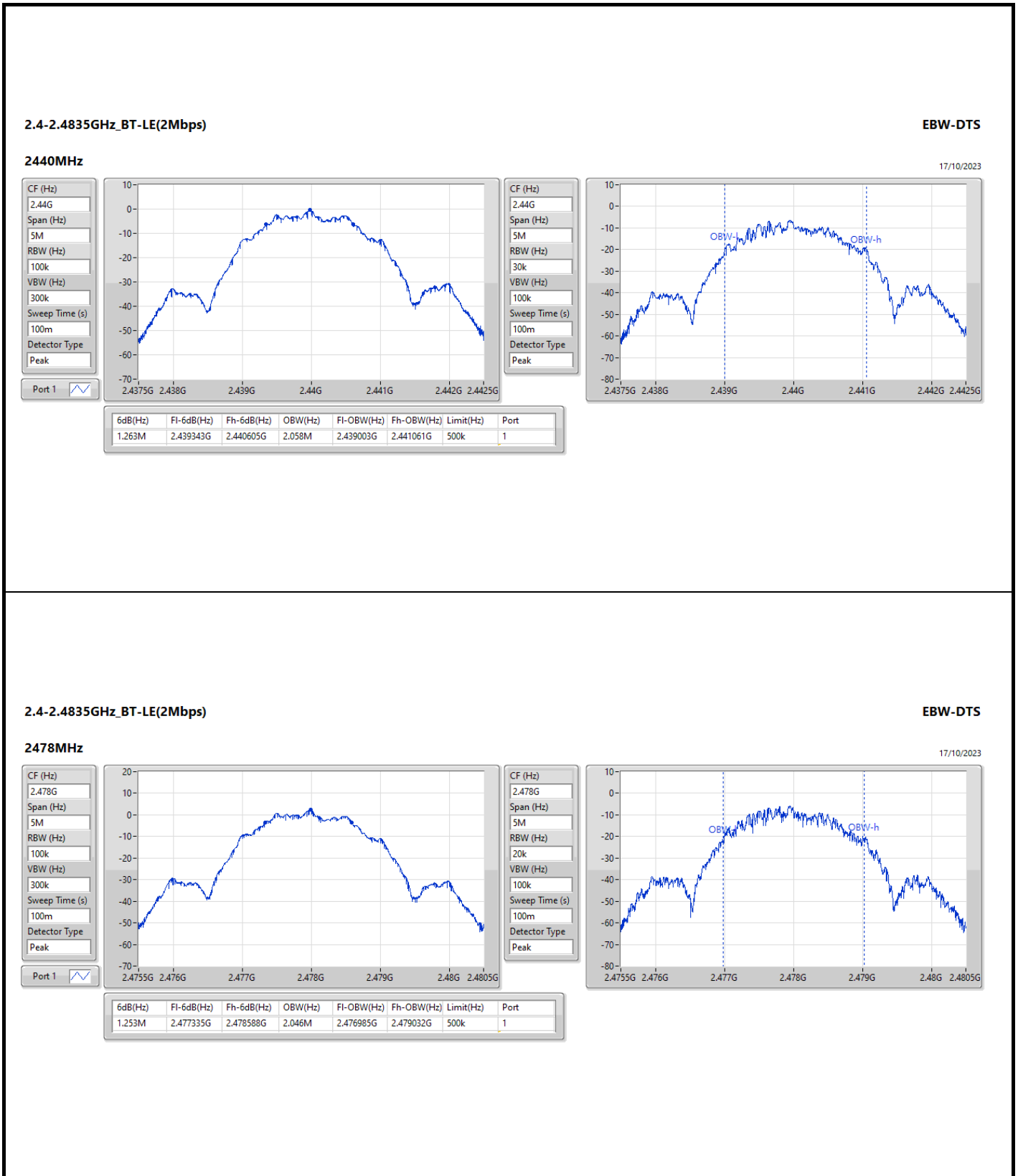



**Summary**

Mode	Total Power (dBm)	Power (W)
2.4-2.4835GHz	-	-
BT-LE(1Mbps)	4.59	0.00288
BT-LE(2Mbps)	4.75	0.00299



Result

Mode	Result	DG (dBi)	Total Power (dBm)	Power Limit (dBm)
BT-LE(1Mbps)	-	-	-	-
2402MHz	Pass	0.97	2.45	30.00
2440MHz	Pass	0.97	2.10	30.00
2480MHz	Pass	0.97	4.59	30.00
BT-LE(2Mbps)	-	-	-	-
2404MHz	Pass	0.97	2.84	30.00
2440MHz	Pass	0.97	1.84	30.00
2478MHz	Pass	0.97	4.75	30.00

DG = Directional Gain; Port X = Port X output power



**Summary**

Mode	Total Power (dBm)	Power (W)
2.4-2.4835GHz	-	-
BT-LE(1Mbps)	2.73	0.00187
BT-LE(2Mbps)	3.82	0.00241



Result

Mode	Result	DG (dBi)	Total Power (dBm)	Power Limit (dBm)
BT-LE(1Mbps)	-	-	-	-
2402MHz	Pass	1.06	2.73	30.00
2440MHz	Pass	1.06	2.45	30.00
2480MHz	Pass	1.06	2.44	30.00
BT-LE(2Mbps)	-	-	-	-
2404MHz	Pass	1.06	3.47	30.00
2440MHz	Pass	1.06	2.06	30.00
2478MHz	Pass	1.06	3.82	30.00

DG = Directional Gain; Port X = Port X output power



**Summary**

Mode	PD (dBm/RBW)
2.4-2.4835GHz	-
BT-LE(1Mbps)	-10.85
BT-LE(2Mbps)	-12.73

RBW = 3kHz;





Result

Mode	Result	DG (dBi)	PD (dBm/RBW)	PD Limit (dBm/RBW)
BT-LE(1Mbps)	-	-	-	-
2402MHz	Pass	0.97	-12.92	8.00
2440MHz	Pass	0.97	-13.20	8.00
2480MHz	Pass	0.97	-10.85	8.00
BT-LE(2Mbps)	-	-	-	-
2404MHz	Pass	0.97	-14.56	8.00
2440MHz	Pass	0.97	-15.61	8.00
2478MHz	Pass	0.97	-12.73	8.00

DG = Directional Gain; RBW = 3kHz;  
PD = trace bin-by-bin of each transmits port summing can be performed maximum power density; Port X = Port X Power Density;

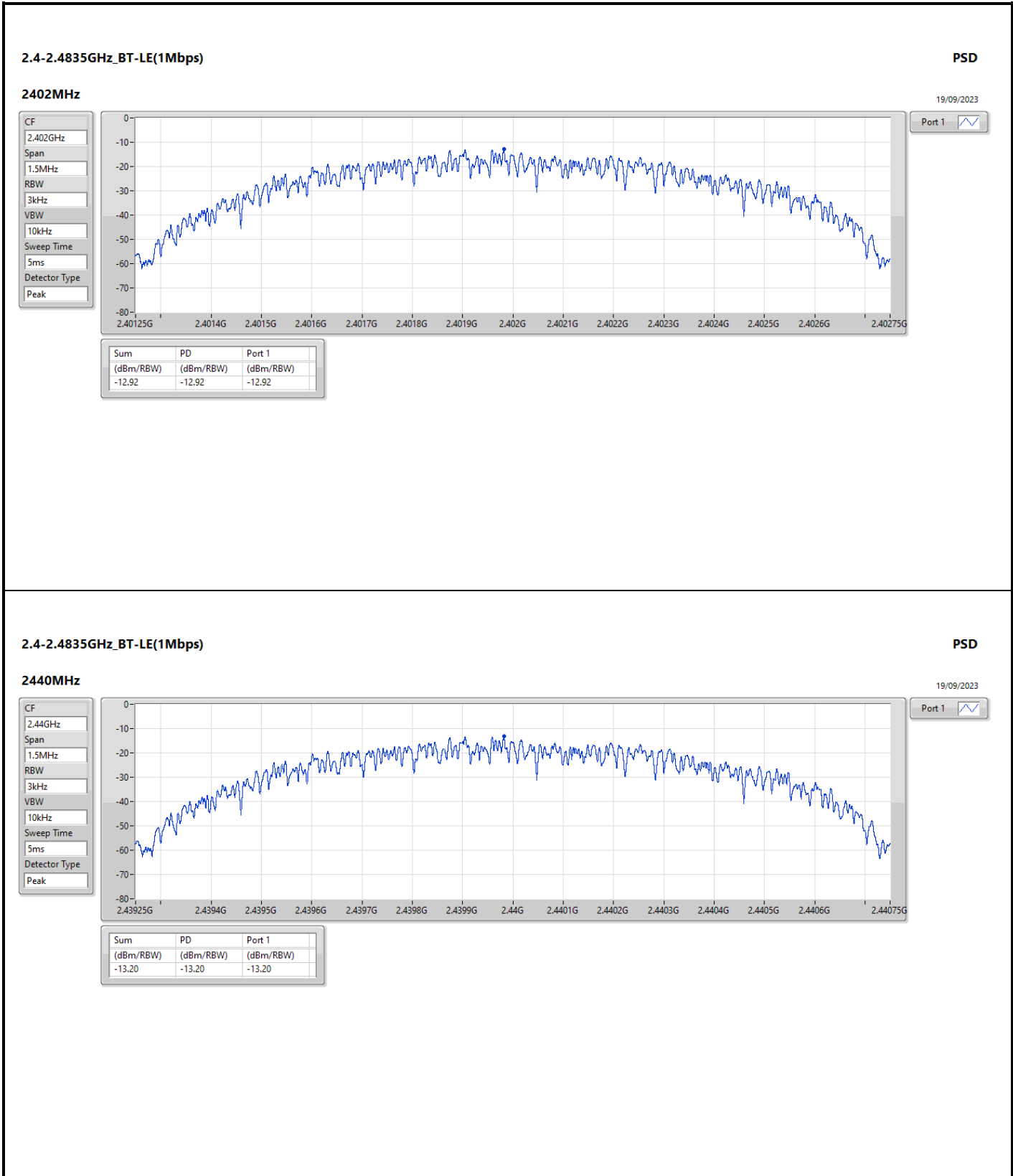

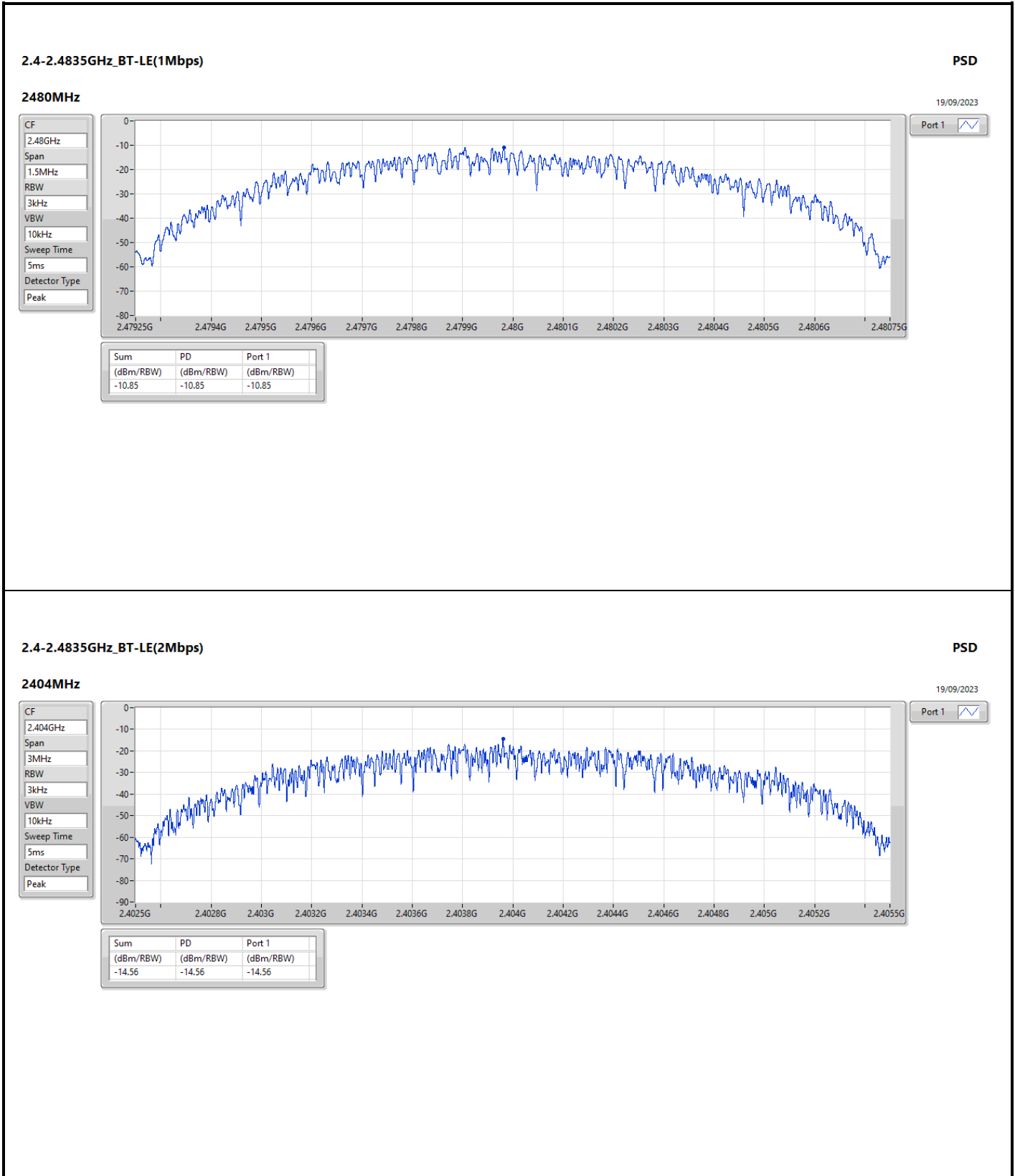

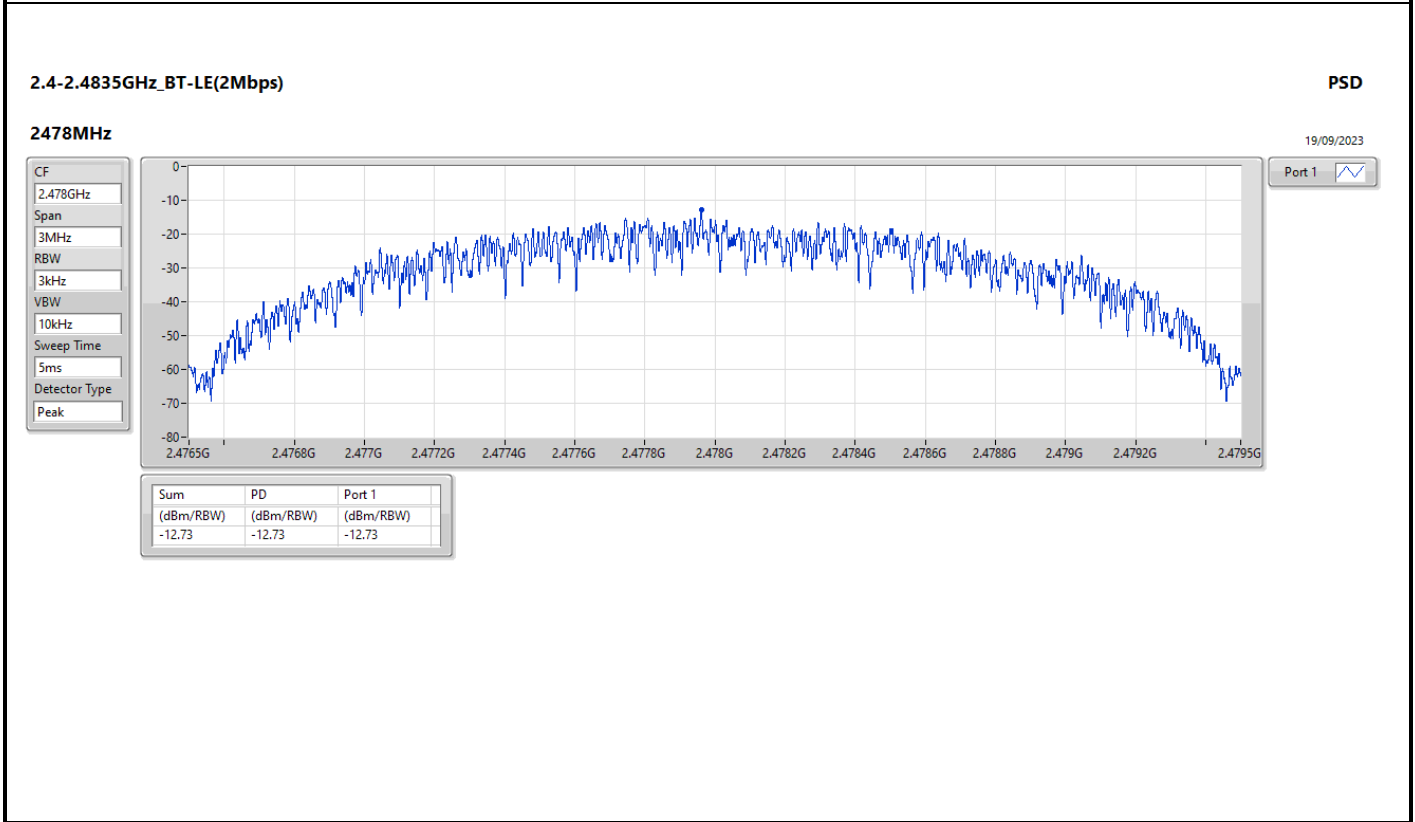
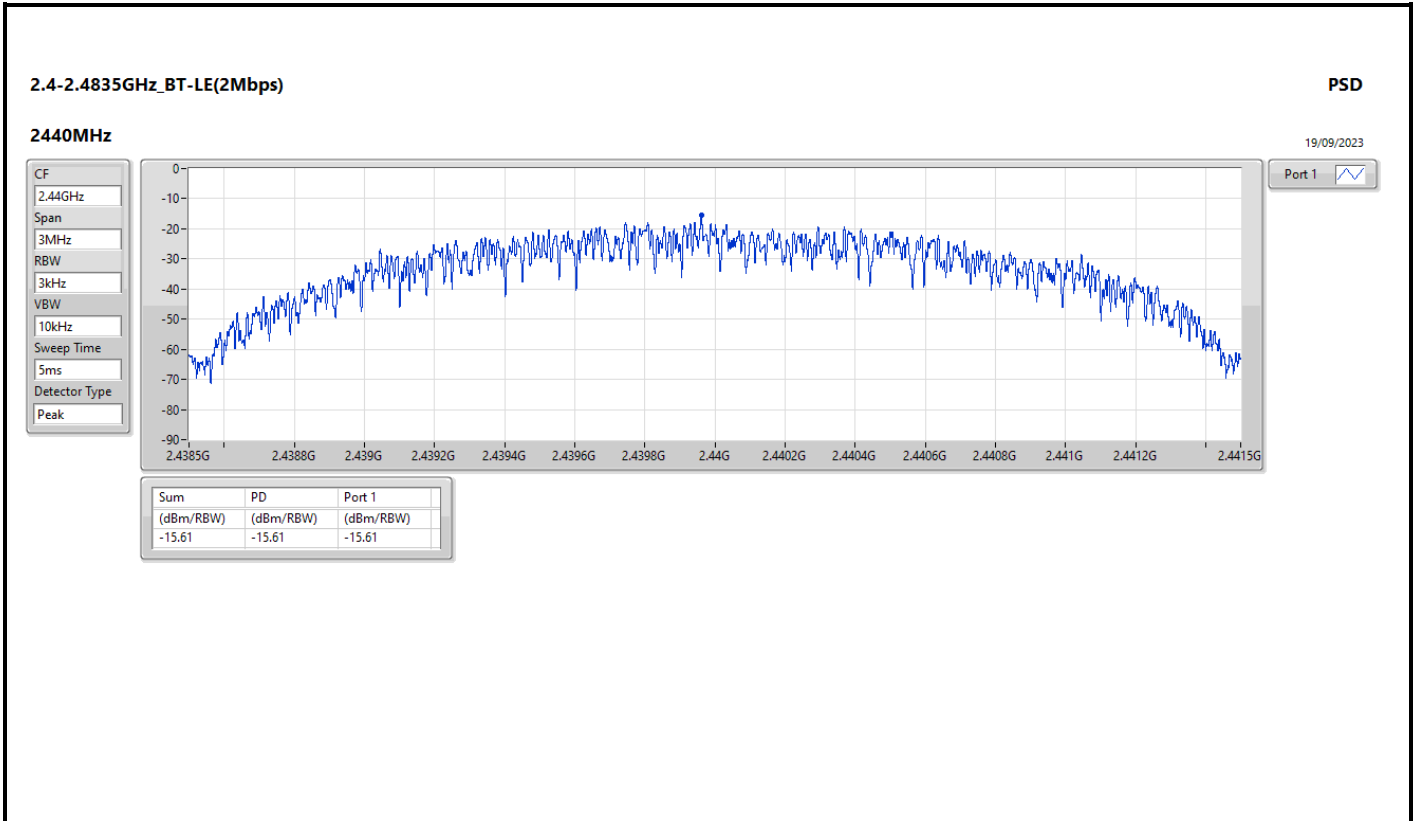



**Summary**

Mode	PD (dBm/RBW)
2.4-2.4835GHz	-
BT-LE(1Mbps)	-12.60
BT-LE(2Mbps)	-13.76

RBW = 3kHz;



Result

Mode	Result	DG (dBi)	PD (dBm/RBW)	PD Limit (dBm/RBW)
BT-LE(1Mbps)	-	-	-	-
2402MHz	Pass	1.06	-12.60	8.00
2440MHz	Pass	1.06	-12.79	8.00
2480MHz	Pass	1.06	-13.04	8.00
BT-LE(2Mbps)	-	-	-	-
2404MHz	Pass	1.06	-14.00	8.00
2440MHz	Pass	1.06	-15.36	8.00
2478MHz	Pass	1.06	-13.76	8.00

DG = Directional Gain; RBW = 3kHz;  
PD = trace bin-by-bin of each transmits port summing can be performed maximum power density; Port X = Port X Power Density;

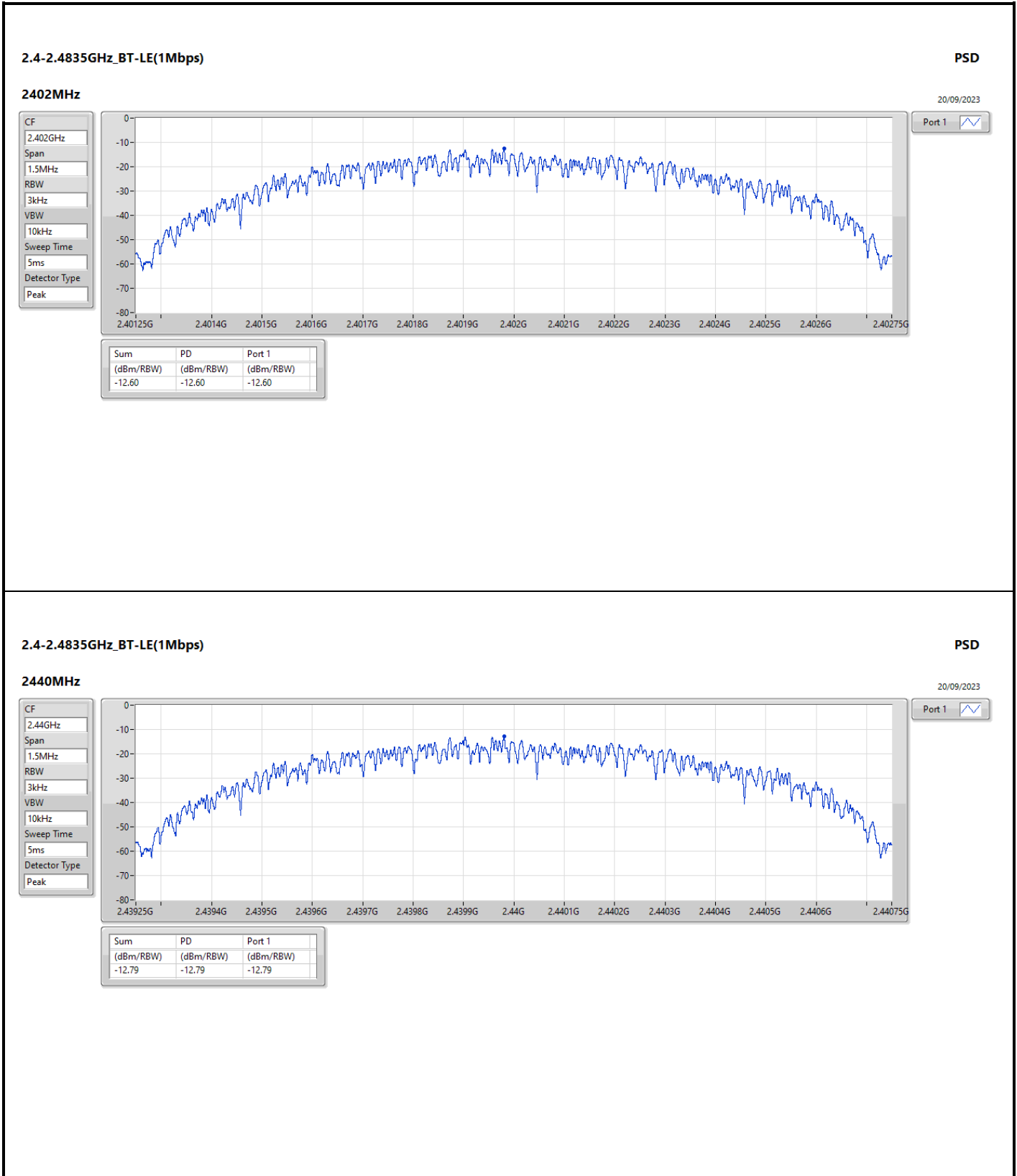

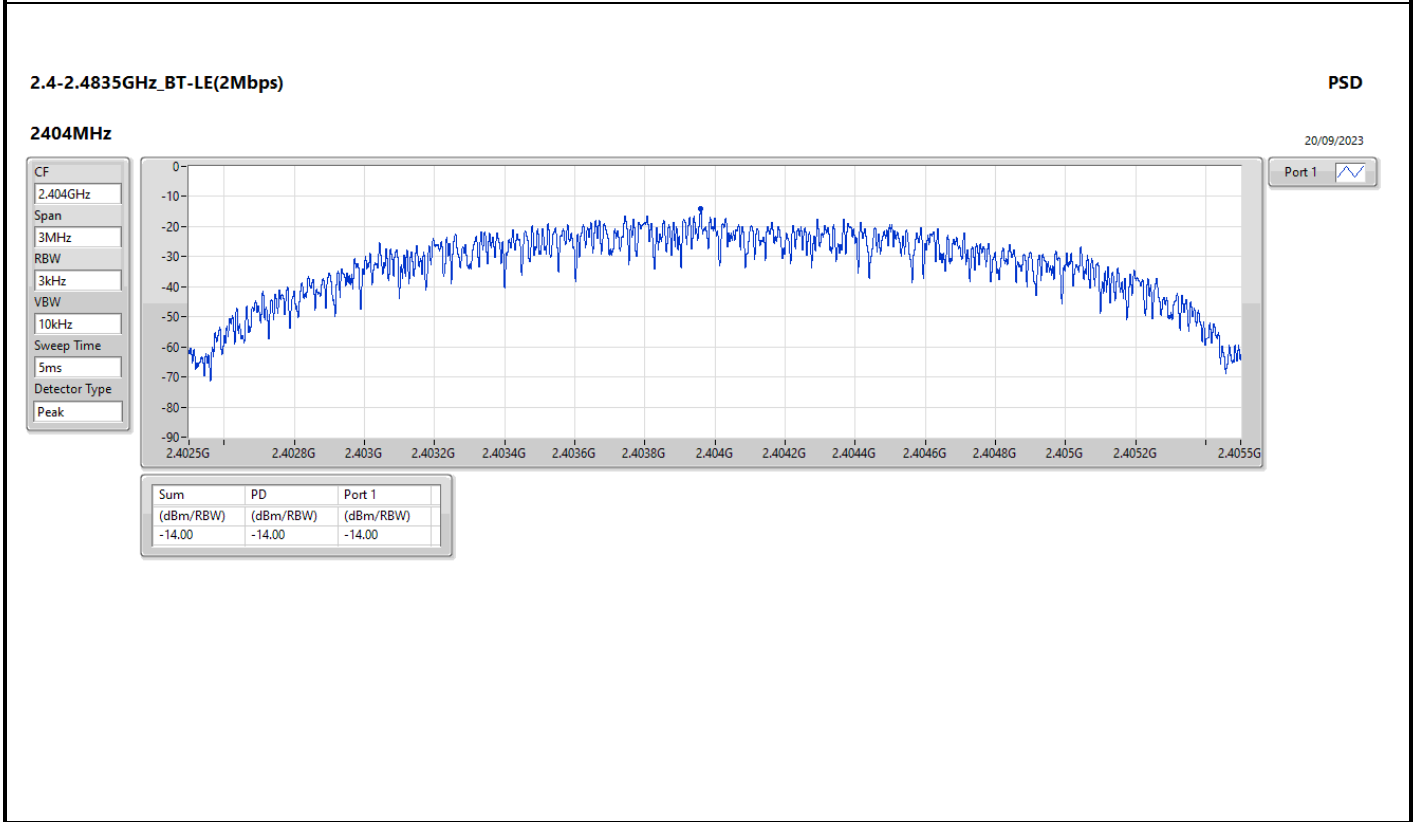
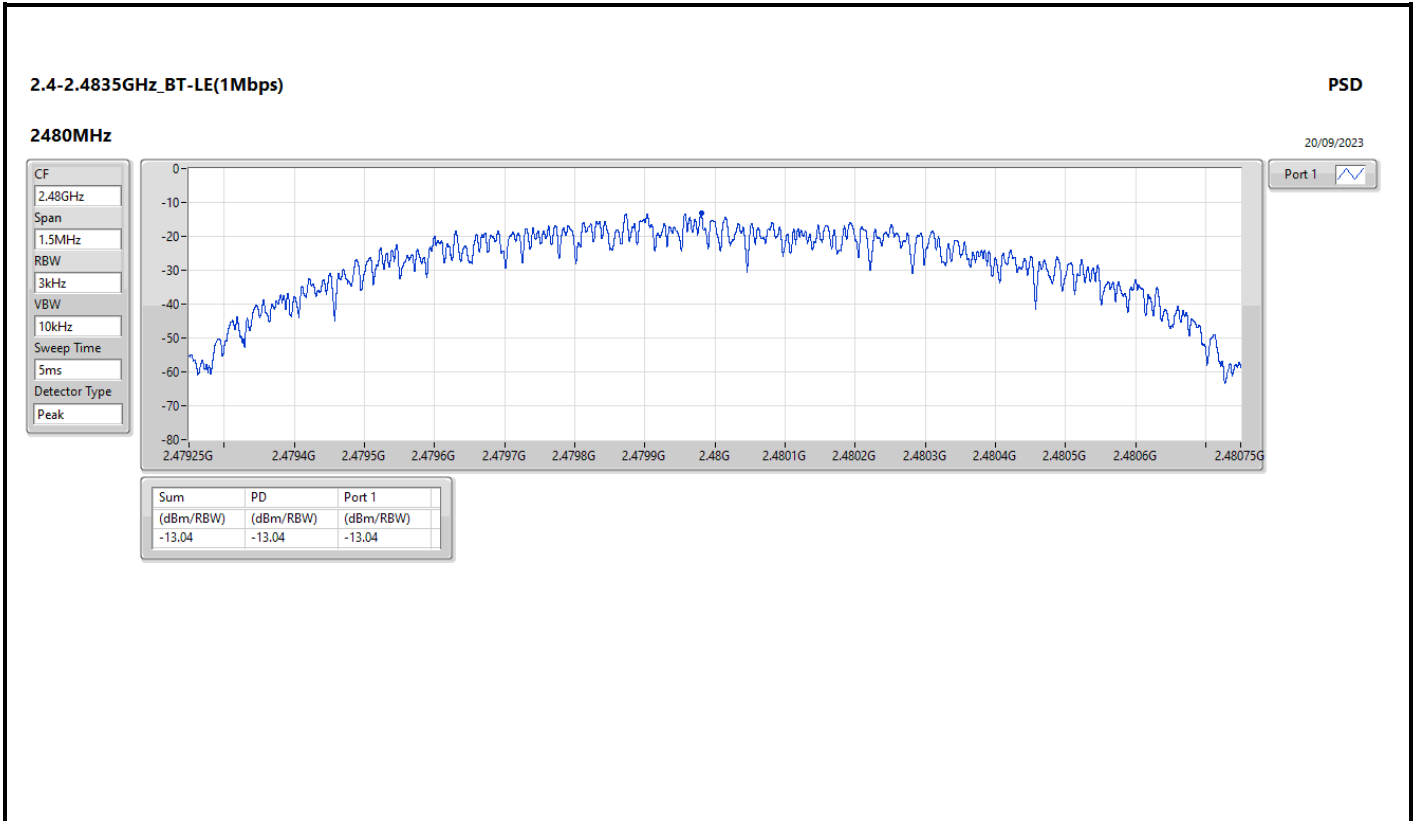



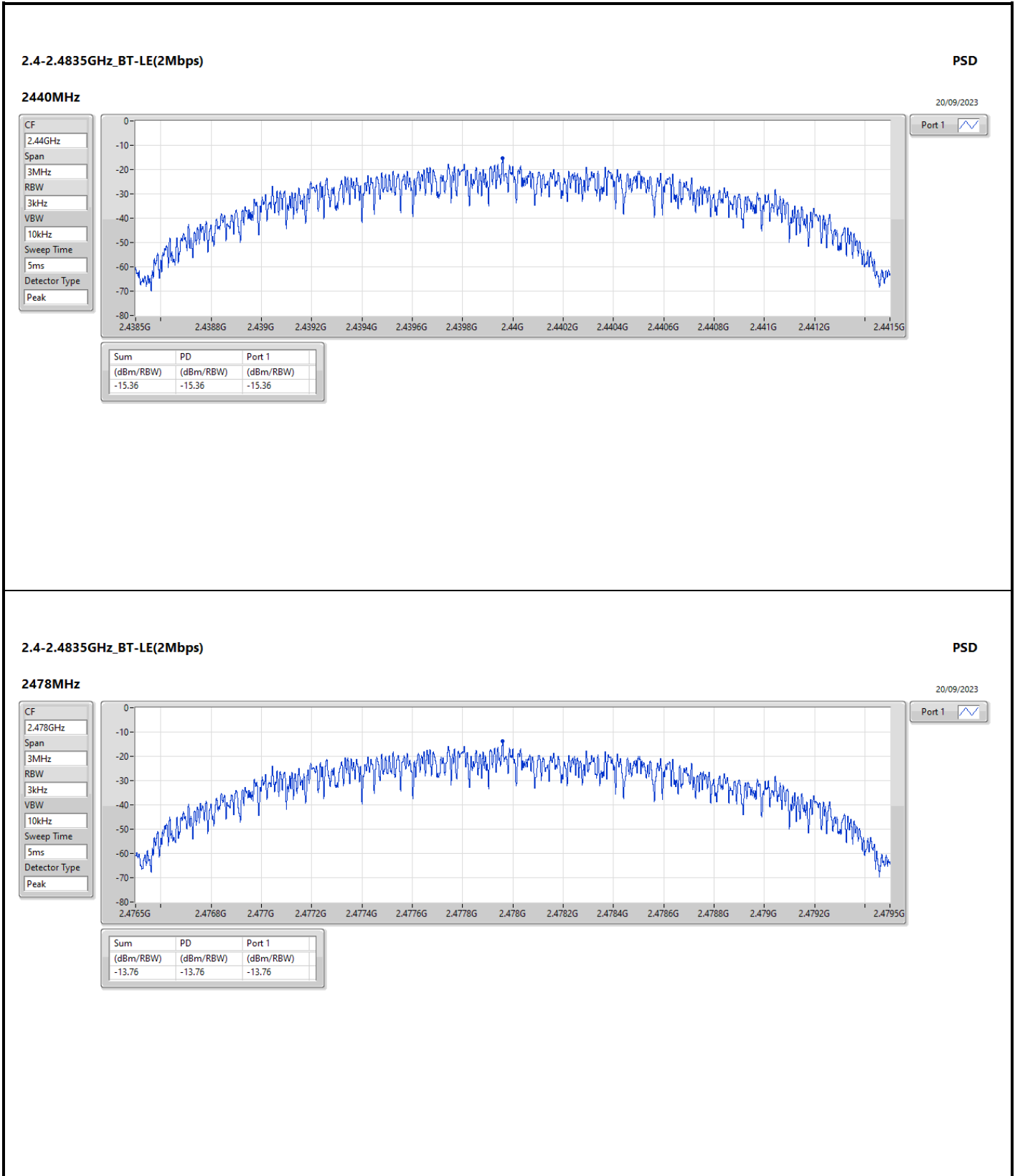



Summary

Mode	Result	Ref (Hz)	Ref (dBm)	Limit (dBm)	Freq (Hz)	Level (dBm)	Freq (Hz)	Level (dBm)	Freq (Hz)	Level (dBm)	Freq (Hz)	Level (dBm)	Freq (Hz)	Level (dBm)	Port
2.4-2.4835GHz	-	-	-	-	-	-	-	-	-	-	-	-	-	-	-
BT-LE(1Mbps)	Pass	2.47983G	1.99	-28.01	2.17555G	-55.23	2.3988G	-52.34	2.4G	-53.75	2.50342G	-52.39	21.68739G	-44.64	1
BT-LE(2Mbps)	Pass	2.47799G	2.60	-27.40	2.16615G	-54.55	2.39972G	-51.87	2.4G	-57.42	2.50146G	-53.06	21.74082G	-45.98	1



Result

Mode	Result	Ref (Hz)	Ref (dBm)	Limit (dBm)	Freq (Hz)	Level (dBm)	Freq (Hz)	Level (dBm)	Freq (Hz)	Level (dBm)	Freq (Hz)	Level (dBm)	Freq (Hz)	Level (dBm)	Port
BT-LE(1Mbps)	-	-	-	-	-	-	-	-	-	-	-	-	-	-	-
2402MHz	Pass	2.47983G	1.99	-28.01	2.17555G	-55.23	2.3988G	-52.34	2.4G	-53.75	2.50342G	-52.39	21.68739G	-44.64	1
2440MHz	Pass	2.47983G	1.99	-28.01	2.1121G	-55.17	2.39884G	-52.81	2.4G	-57.38	2.50134G	-52.93	21.7127G	-45.11	1
2480MHz	Pass	2.47983G	1.99	-28.01	2.30363G	-55.09	2.3986G	-52.41	2.4G	-56.68	2.50058G	-52.73	21.67895G	-45.45	1
BT-LE(2Mbps)	-	-	-	-	-	-	-	-	-	-	-	-	-	-	-
2404MHz	Pass	2.47799G	2.60	-27.40	2.16615G	-54.55	2.39972G	-51.87	2.4G	-57.42	2.50146G	-53.06	21.74082G	-45.98	1
2440MHz	Pass	2.47799G	2.60	-27.40	2.30128G	-55.01	2.39172G	-52.46	2.4G	-56.24	2.50178G	-52.69	21.79144G	-45.08	1
2478MHz	Pass	2.47799G	2.60	-27.40	2.19905G	-53.43	2.39444G	-52.57	2.4G	-57.27	2.50222G	-53.11	21.71551G	-45.73	1

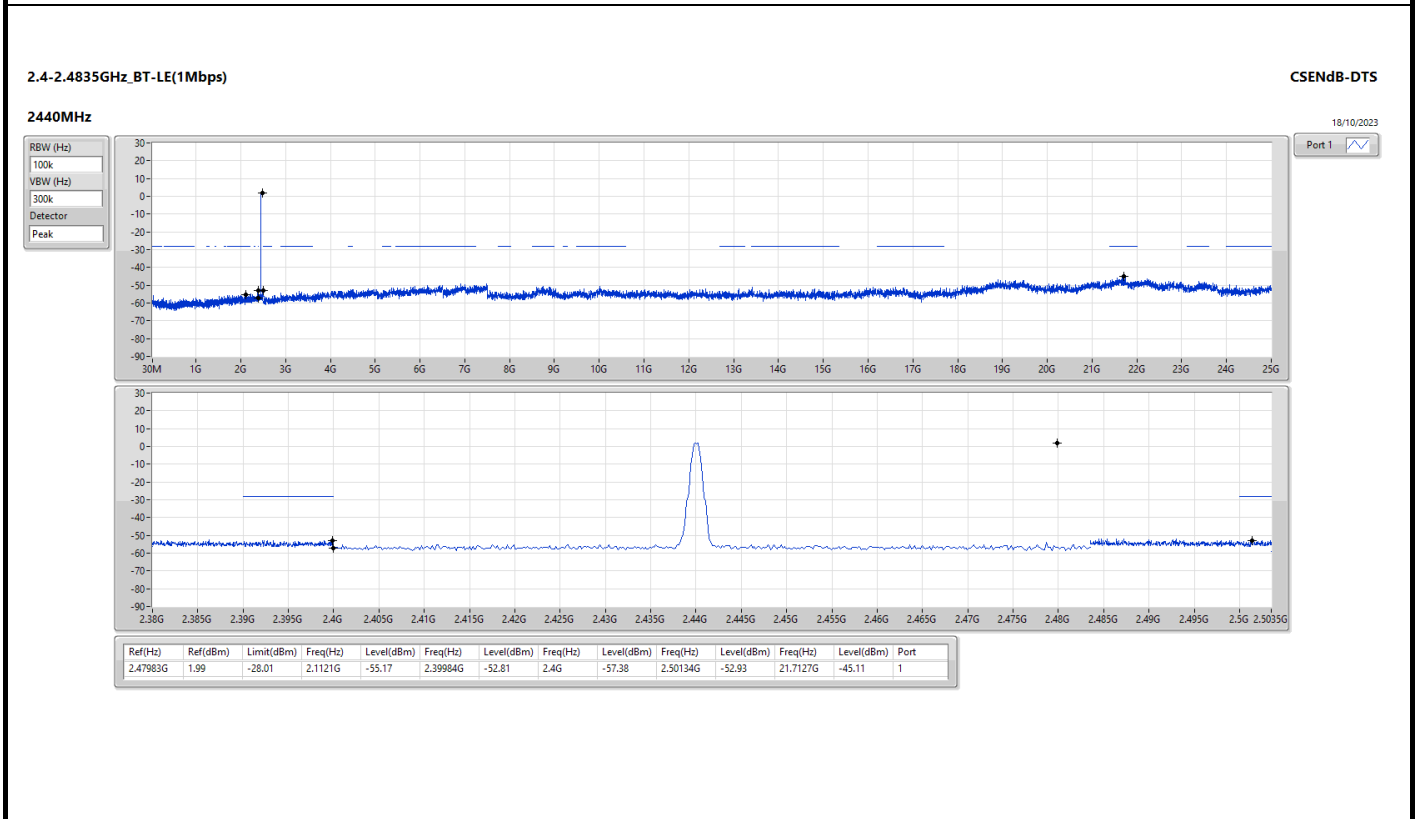
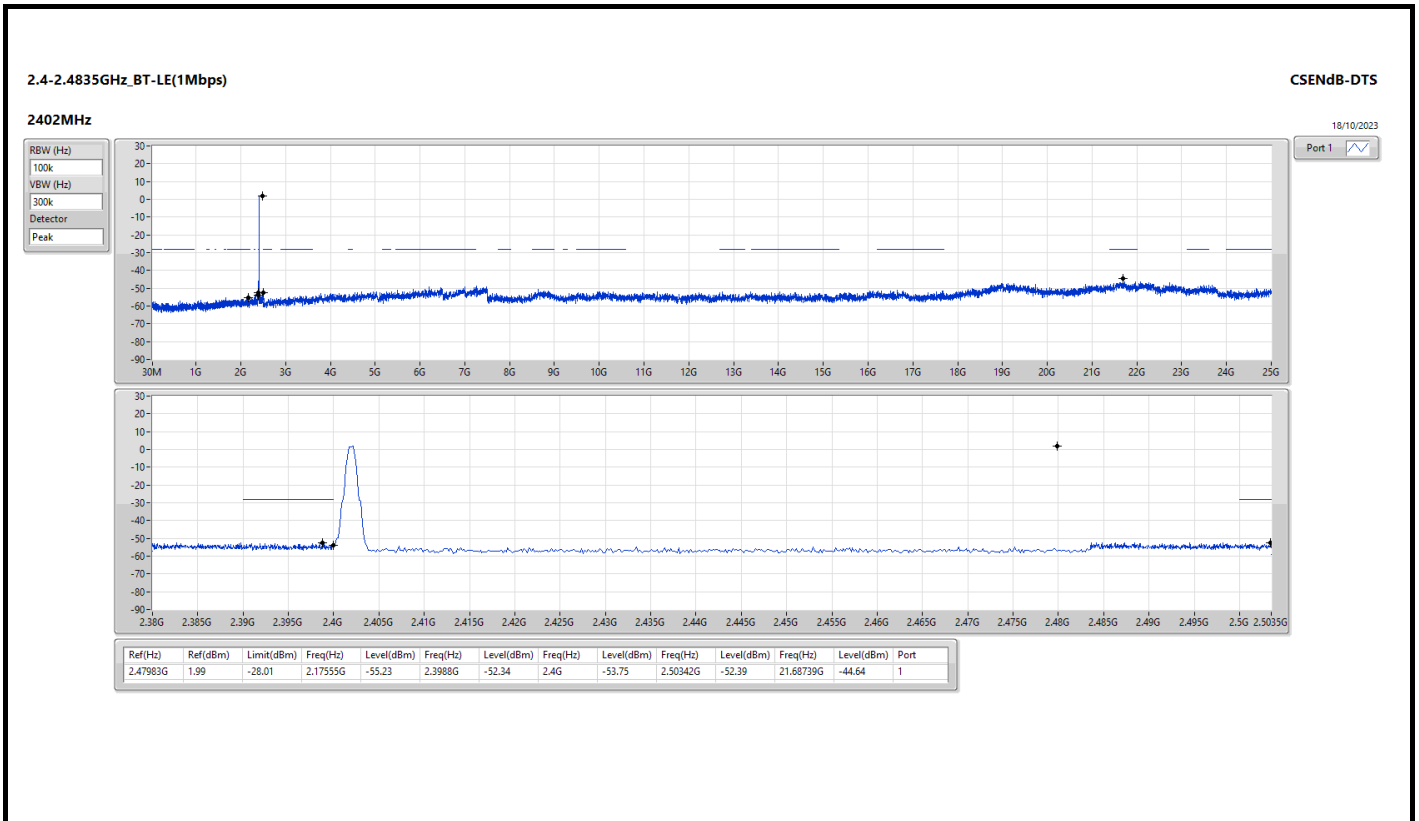

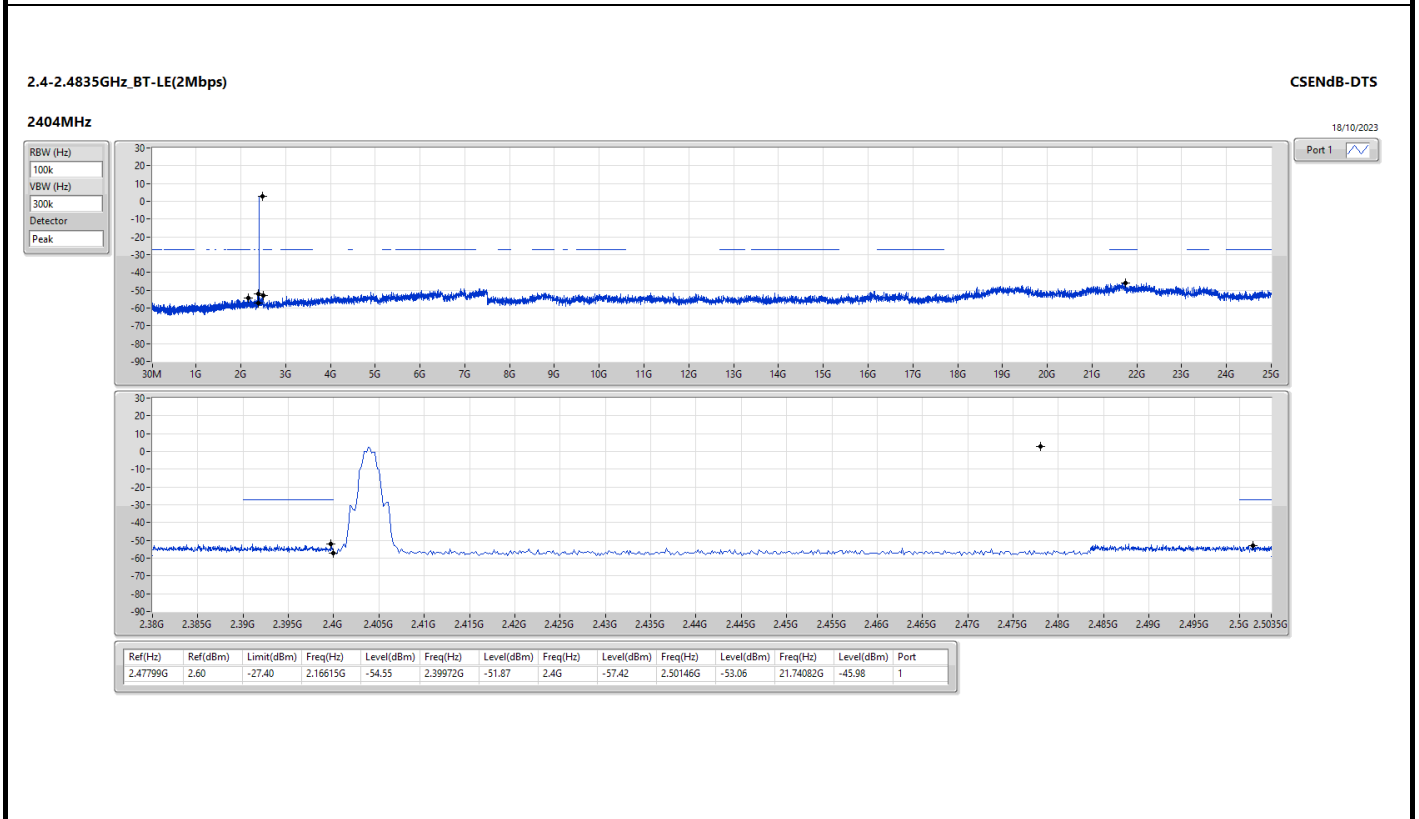
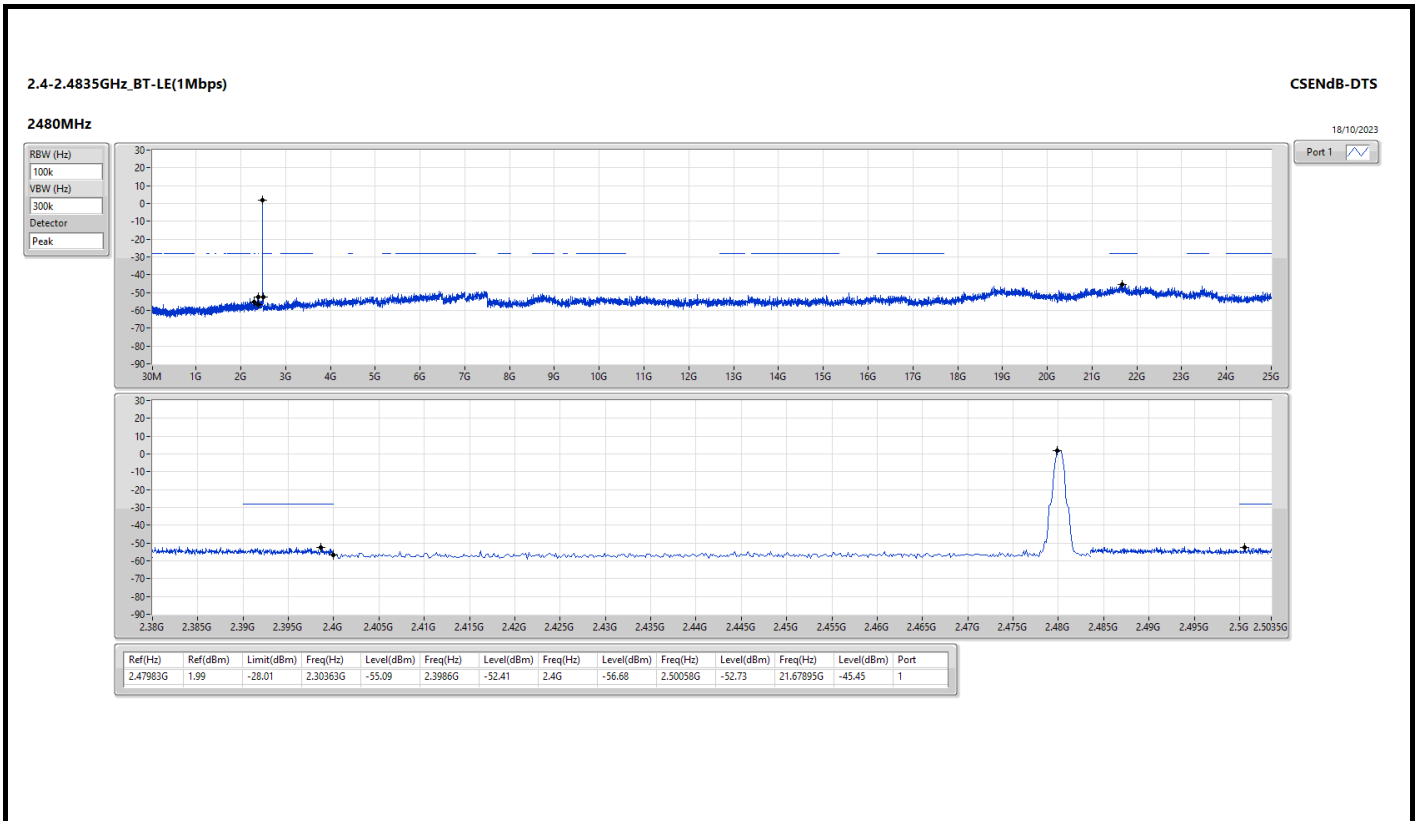

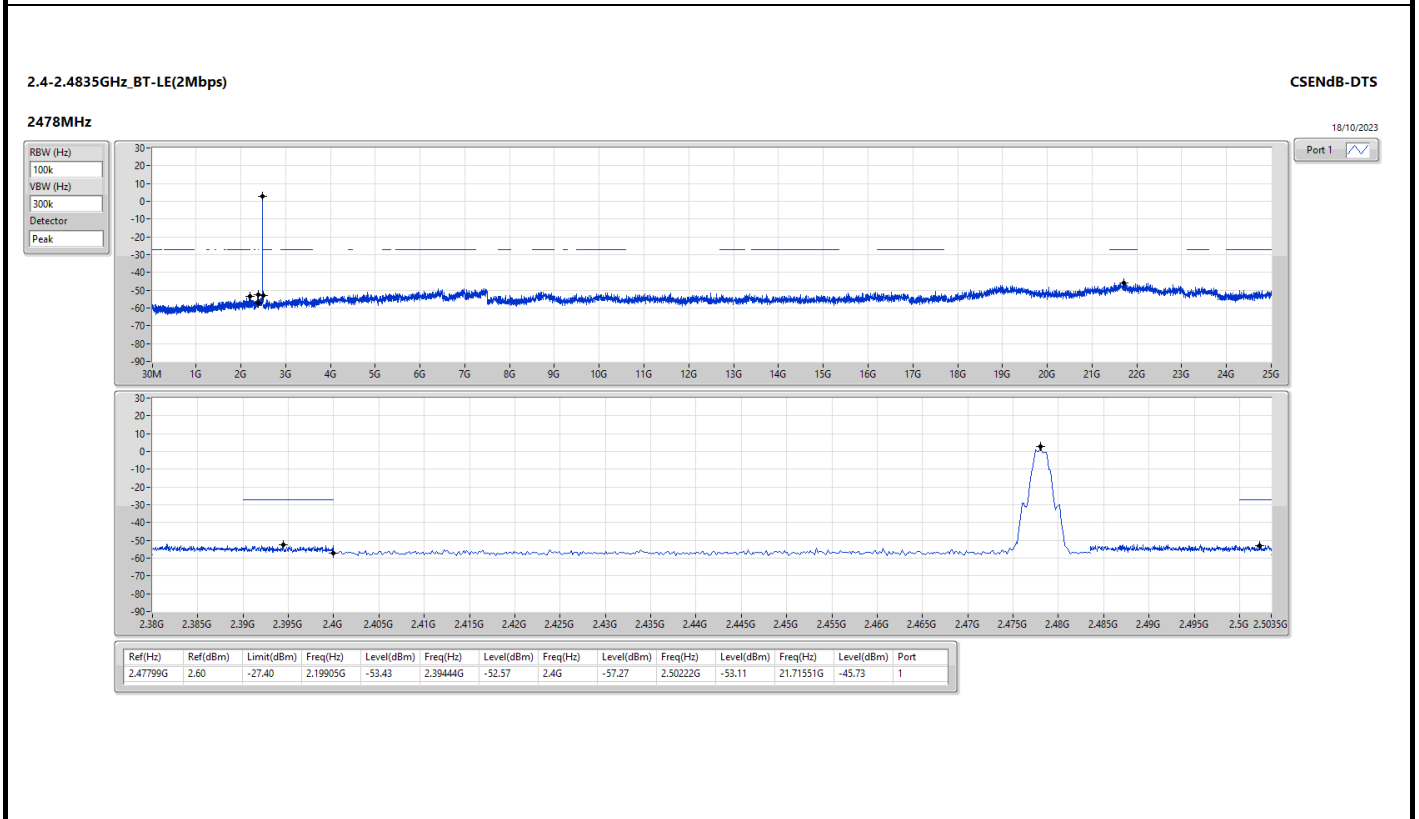
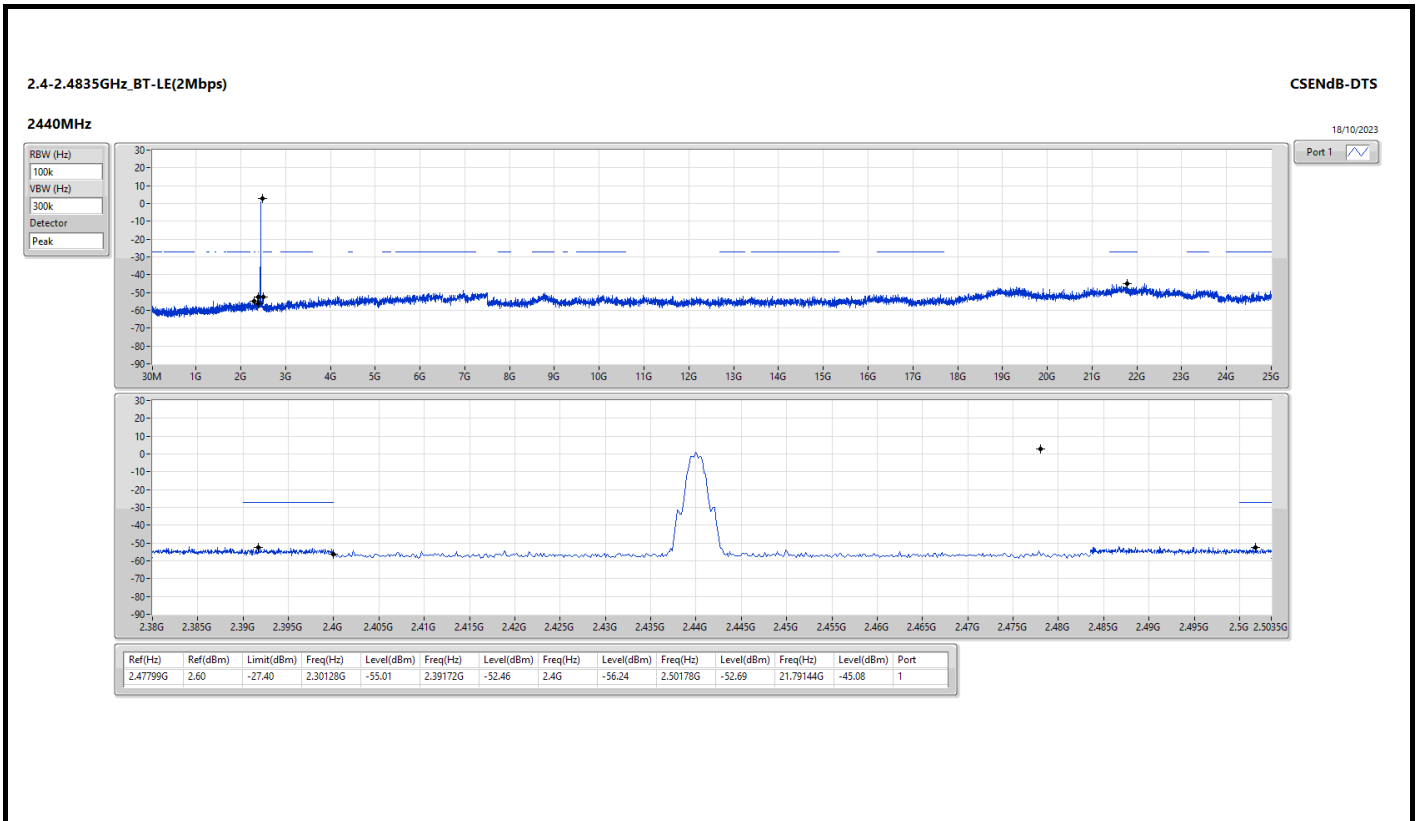



Summary

Mode	Result	Ref (Hz)	Ref (dBm)	Limit (dBm)	Freq (Hz)	Level (dBm)	Freq (Hz)	Level (dBm)	Freq (Hz)	Level (dBm)	Freq (Hz)	Level (dBm)	Freq (Hz)	Level (dBm)	Port
2.4-2.4835GHz	-	-	-	-	-	-	-	-	-	-	-	-	-	-	-
BT-LE(1Mbps)	Pass	2.47983G	1.22	-28.78	2.01105G	-55.65	2.39312G	-52.75	2.4G	-56.97	2.5003G	-51.39	21.79144G	-46.29	1
BT-LE(2Mbps)	Pass	2.47799G	2.20	-27.80	1.82305G	-55.19	2.3976G	-51.66	2.4G	-57.91	2.50218G	-52.22	21.63959G	-45.18	1



Result

Mode	Result	Ref (Hz)	Ref (dBm)	Limit (dBm)	Freq (Hz)	Level (dBm)	Freq (Hz)	Level (dBm)	Freq (Hz)	Level (dBm)	Freq (Hz)	Level (dBm)	Freq (Hz)	Level (dBm)	Port
BT-LE(1Mbps)	-	-	-	-	-	-	-	-	-	-	-	-	-	-	-
2402MHz	Pass	2.47983G	1.22	-28.78	2.01105G	-55.65	2.39312G	-52.75	2.4G	-56.97	2.5003G	-51.39	21.79144G	-46.29	1
2440MHz	Pass	2.47983G	1.22	-28.78	2.18143G	-55.39	2.39076G	-53.12	2.4G	-56.59	2.50166G	-52.12	21.76894G	-45.37	1
2480MHz	Pass	2.47983G	1.22	-28.78	1.85008G	-53.45	2.3928G	-52.69	2.4G	-55.40	2.5007G	-52.79	21.60303G	-46.03	1
BT-LE(2Mbps)	-	-	-	-	-	-	-	-	-	-	-	-	-	-	-
2404MHz	Pass	2.47799G	2.20	-27.80	2.05688G	-55.14	2.3978G	-52.85	2.4G	-56.33	2.50134G	-53.46	21.73801G	-46.02	1
2440MHz	Pass	2.47799G	2.20	-27.80	1.82305G	-55.19	2.3976G	-51.66	2.4G	-57.91	2.50218G	-52.22	21.63959G	-45.18	1
2478MHz	Pass	2.47799G	2.20	-27.80	2.07803G	-55.01	2.39196G	-53.04	2.4G	-57.19	2.5009G	-52.09	21.63677G	-45.23	1



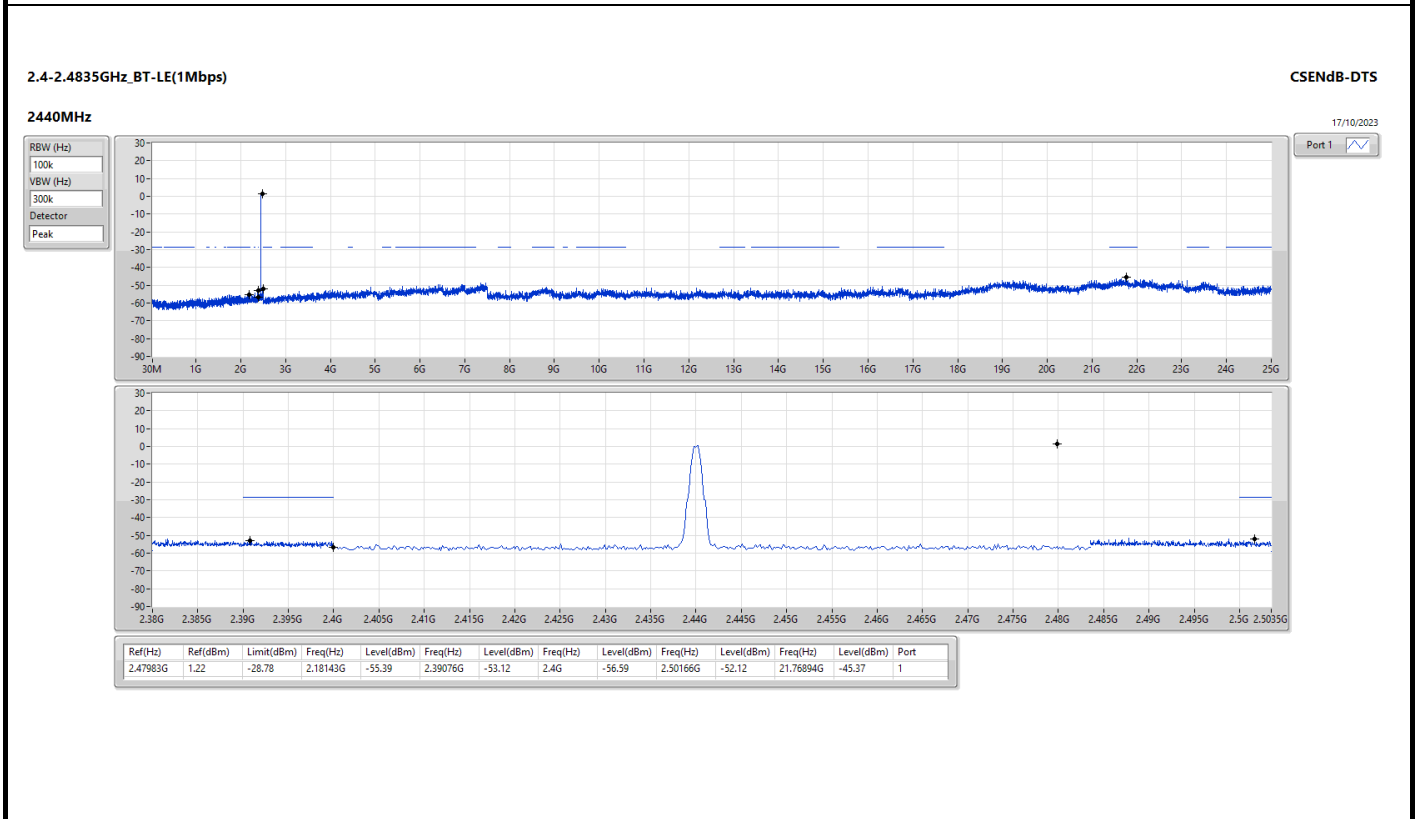
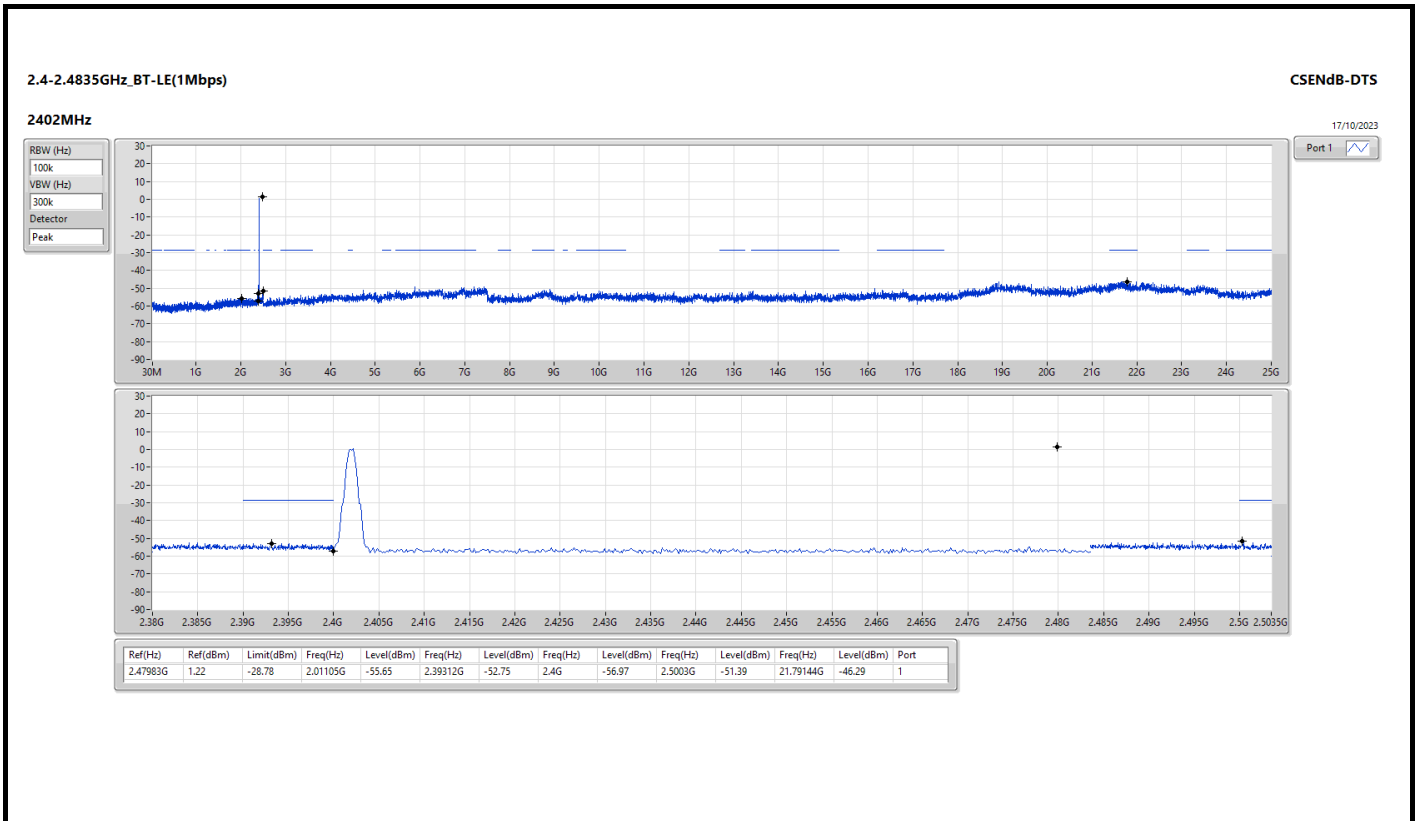

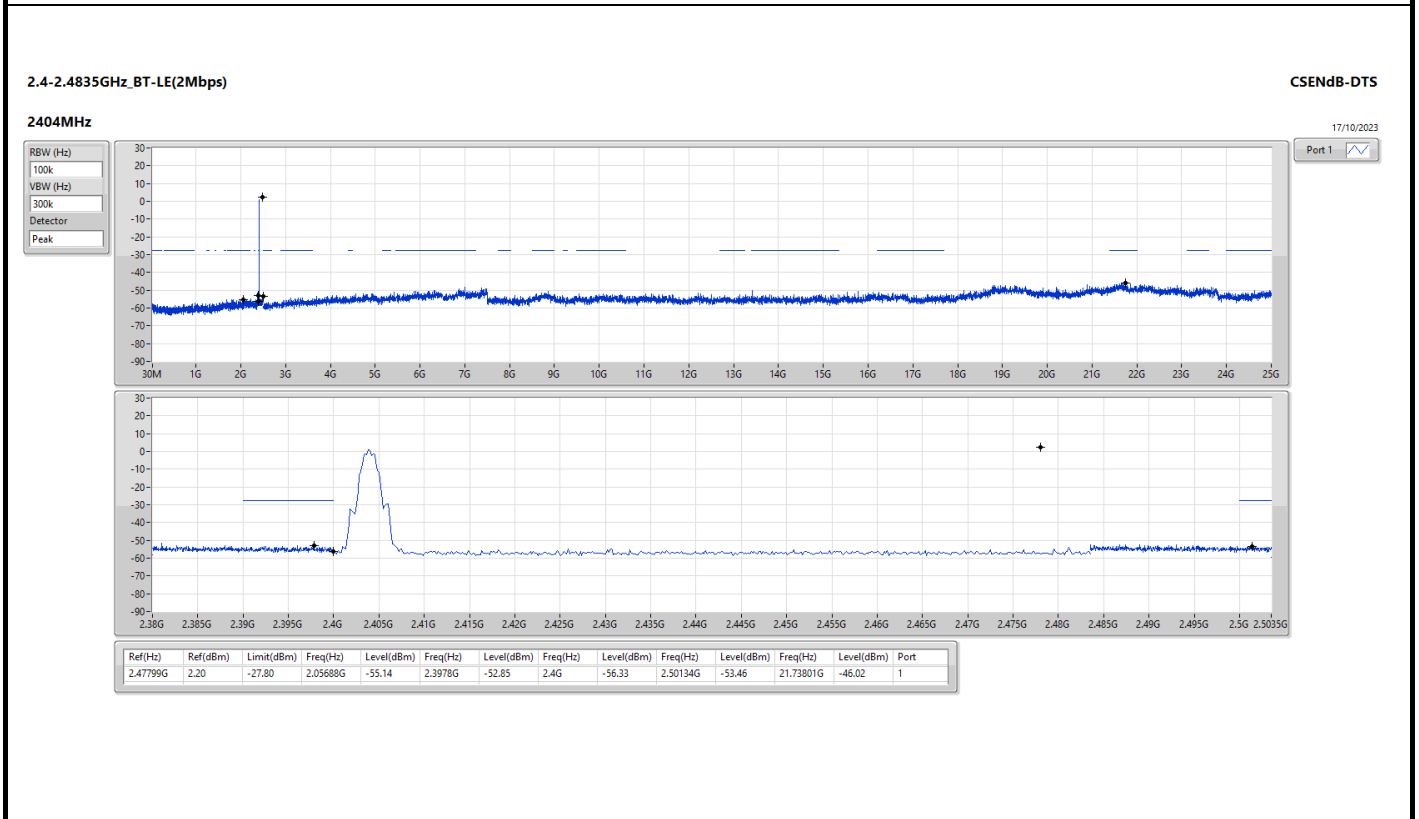
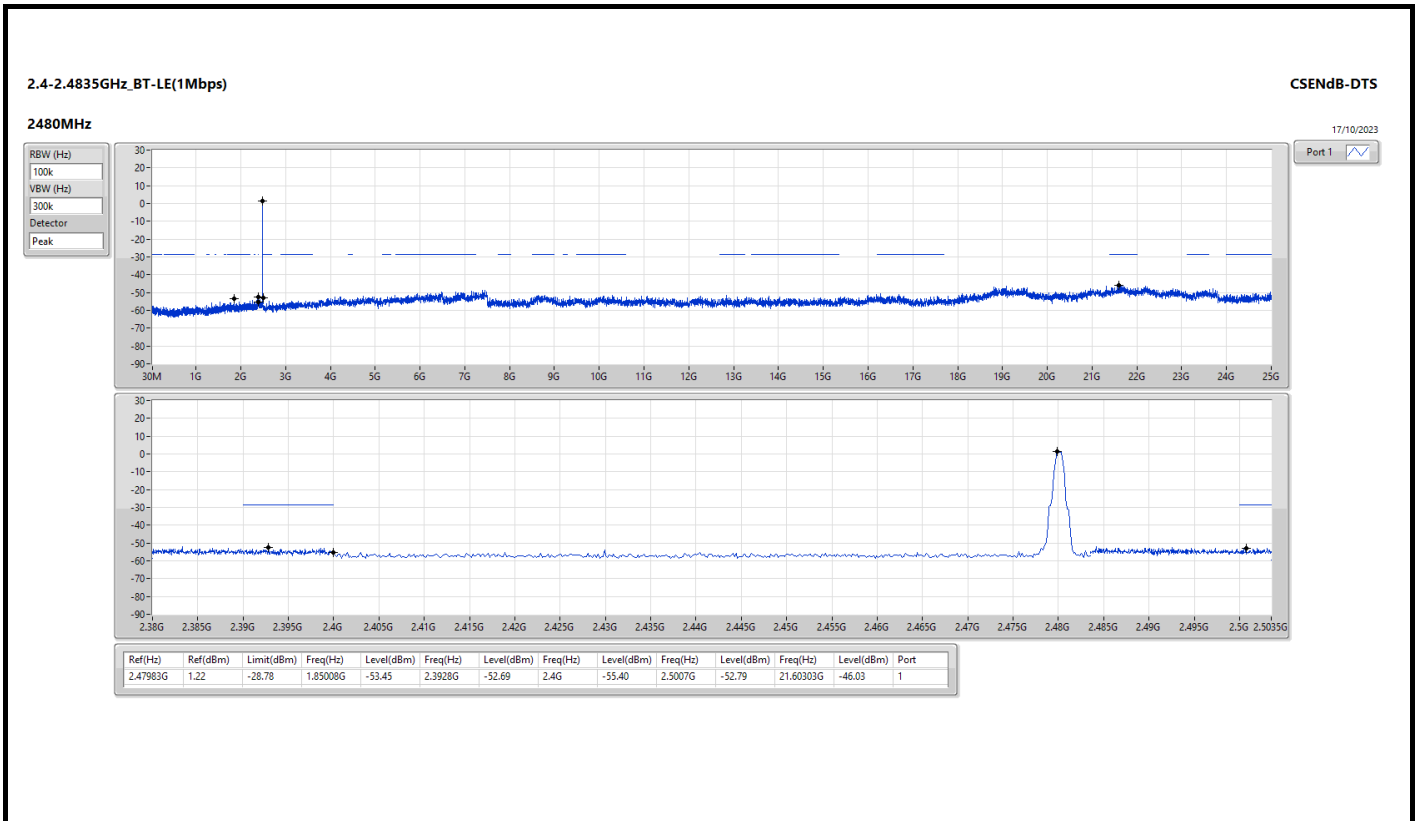

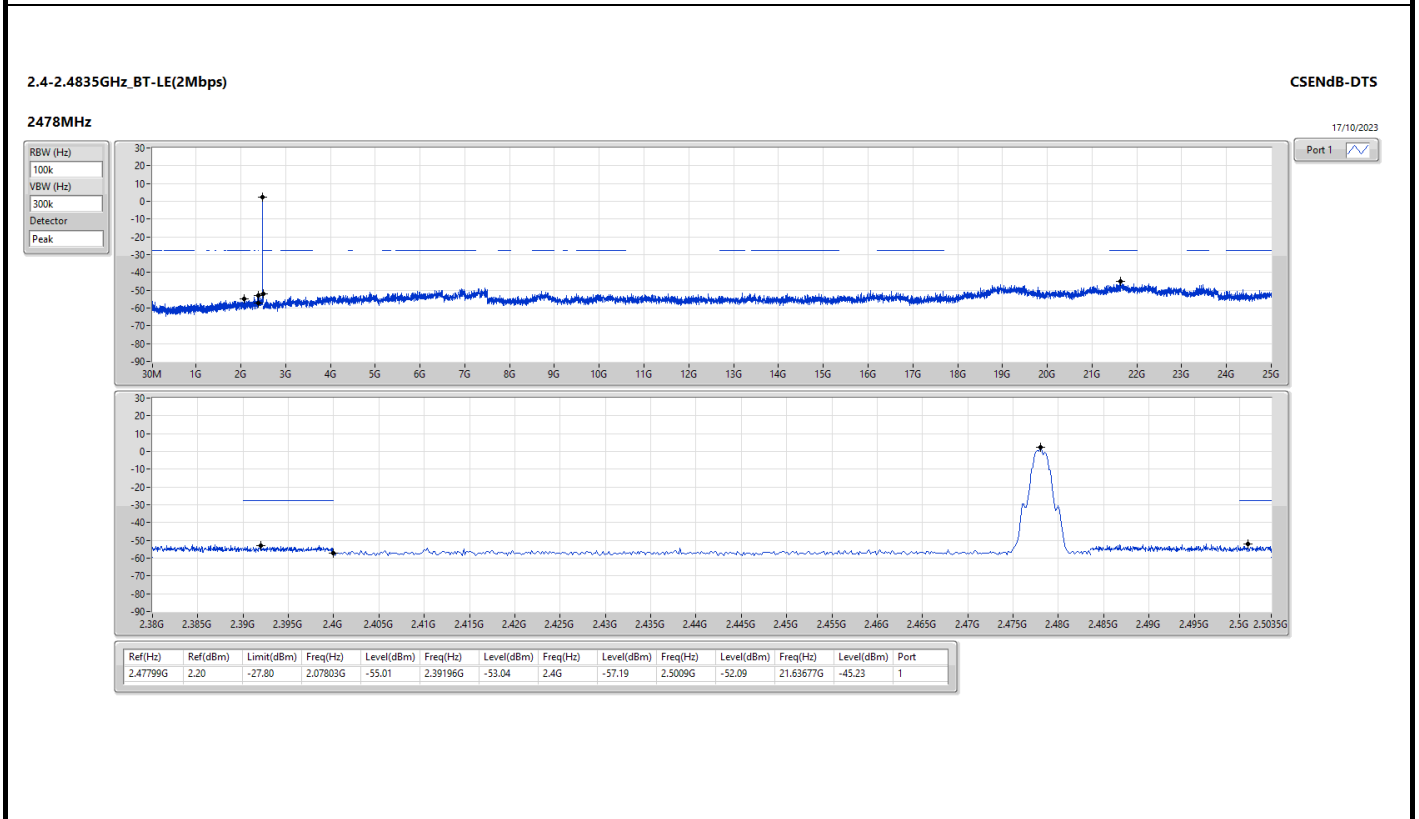
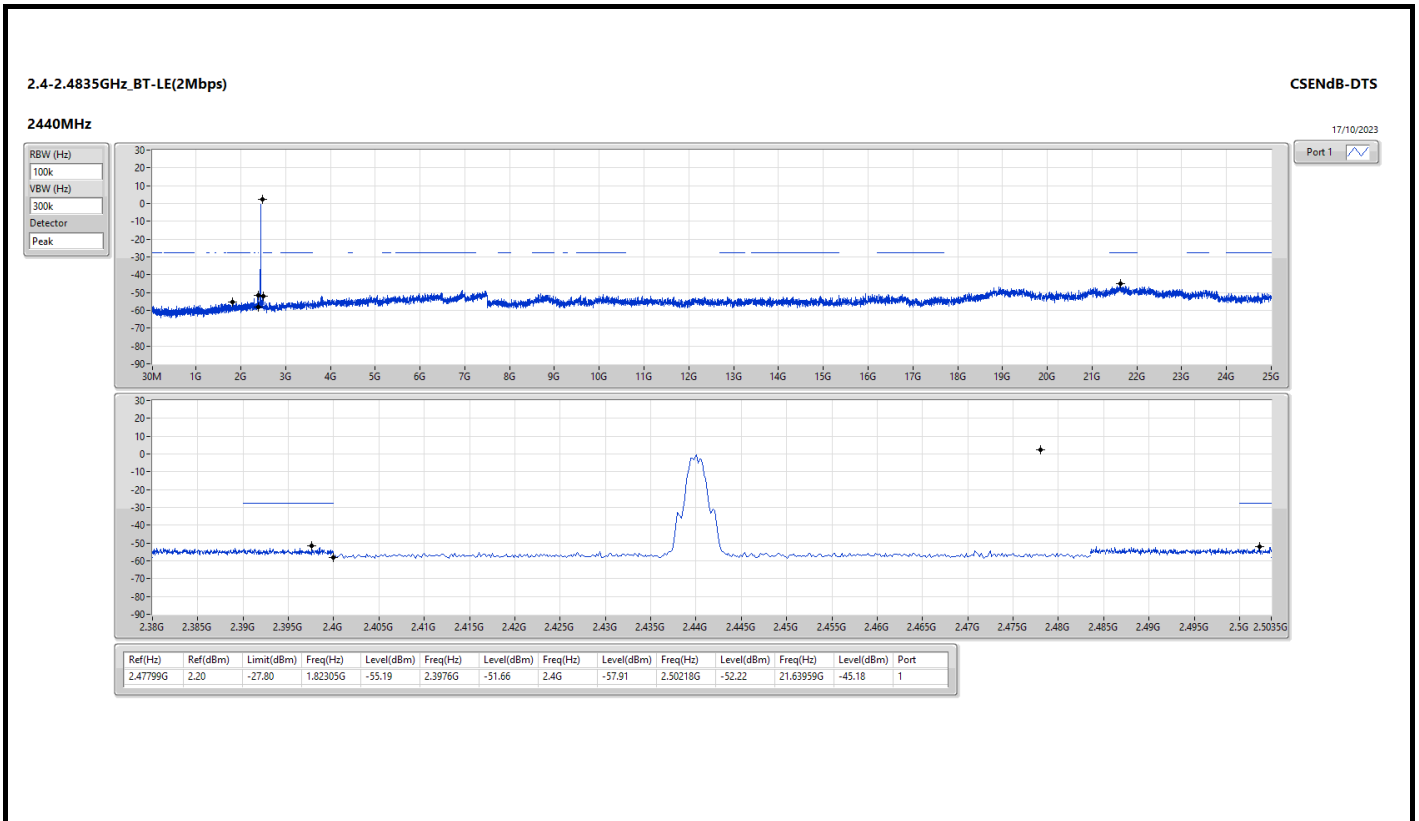



Summary

Mode	Result	Type	Freq (Hz)	Level (dBuV/m)	Limit (dBuV/m)	Margin (dB)	Dist (m)	Condition	Azimuth (°)	Height (m)
2.4-2.4835GHz	-	-	-	-	-	-	-	-	-	-
BT-LE(2Mbps)	Pass	PK	45.52M	31.70	40.00	-8.30	3	Vertical	360	1.00



Result

Mode	Result	Type	Freq (Hz)	Level (dBuV/m)	Limit (dBuV/m)	Margin (dB)	Dist (m)	Condition	Azimuth (°)	Height (m)
BT-LE(2Mbps)	-	-	-	-	-	-	-	-	-	-
2478MHz	Pass	PK	45.52M	28.31	40.00	-11.69	3	Vertical	360	1.00
2478MHz	Pass	PK	66.86M	22.66	40.00	-17.34	3	Vertical	360	1.00
2478MHz	Pass	PK	150.28M	21.60	43.50	-21.90	3	Vertical	360	1.00
2478MHz	Pass	PK	289.96M	23.10	46.00	-22.90	3	Vertical	360	1.00
2478MHz	Pass	PK	515M	30.59	46.00	-15.41	3	Vertical	360	1.00
2478MHz	Pass	PK	866.14M	28.14	46.00	-17.86	3	Vertical	360	1.00
2478MHz	Pass	PK	142.52M	23.90	43.50	-19.60	3	Horizontal	0	1.00
2478MHz	Pass	PK	192.96M	27.57	43.50	-15.93	3	Horizontal	0	1.00
2478MHz	Pass	PK	289.96M	26.63	46.00	-19.37	3	Horizontal	0	1.00
2478MHz	Pass	PK	447.1M	25.91	46.00	-20.09	3	Horizontal	0	1.00
2478MHz	Pass	PK	623.64M	26.40	46.00	-19.60	3	Horizontal	0	1.00
2478MHz	Pass	PK	786.6M	27.10	46.00	-18.90	3	Horizontal	0	1.00
2478MHz	Pass	PK	45.52M	31.70	40.00	-8.30	3	Vertical	360	1.00
2478MHz	Pass	PK	88.2M	27.98	43.50	-15.52	3	Vertical	360	1.00
2478MHz	Pass	PK	210.42M	29.55	43.50	-13.95	3	Vertical	360	1.00
2478MHz	Pass	PK	410.24M	29.00	46.00	-17.00	3	Vertical	360	1.00
2478MHz	Pass	PK	631.4M	32.82	46.00	-13.18	3	Vertical	360	1.00
2478MHz	Pass	PK	817.64M	28.54	46.00	-17.46	3	Vertical	360	1.00
2478MHz	Pass	PK	88.2M	30.49	43.50	-13.01	3	Horizontal	0	1.00
2478MHz	Pass	PK	210.42M	34.37	43.50	-9.13	3	Horizontal	0	1.00
2478MHz	Pass	PK	398.6M	28.25	46.00	-17.75	3	Horizontal	0	1.00
2478MHz	Pass	PK	631.4M	28.76	46.00	-17.24	3	Horizontal	0	1.00
2478MHz	Pass	PK	741.98M	30.22	46.00	-15.78	3	Horizontal	0	1.00
2478MHz	Pass	PK	798.24M	30.86	46.00	-15.14	3	Horizontal	0	1.00

2.4-2.4835GHz\_BT-LE(2Mbps)

2478MHz\_Adapter

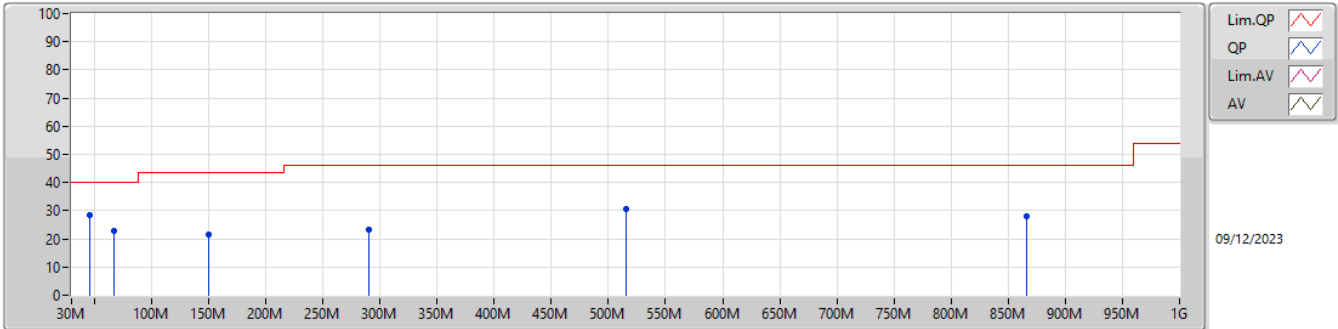

Type	Freq (Hz)	Level (dBuV/m)	Limit (dBuV/m)	Margin (dB)	Factor (dB)	Dist (m)	Condition	Azimuth (°)	Height (m)	Raw (dBuV)	AF (dB)	CL (dB)	PA (dB)
PK	45.52M	28.31	40.00	-11.69	-11.49	3	Vertical	360	1.00	39.80	15.39	0.51	27.39
PK	66.86M	22.66	40.00	-17.34	-15.40	3	Vertical	360	1.00	38.06	11.38	0.62	27.40
PK	150.28M	21.60	43.50	-21.90	-10.55	3	Vertical	360	1.00	32.15	15.68	0.91	27.14
PK	289.96M	23.10	46.00	-22.90	-7.39	3	Vertical	360	1.00	30.49	18.09	1.26	26.74
PK	515M	30.59	46.00	-15.41	-4.00	3	Vertical	360	1.00	34.59	22.55	1.67	28.22
PK	866.14M	28.14	46.00	-17.86	-0.48	3	Vertical	360	1.00	28.62	25.33	2.17	27.98

2.4-2.4835GHz\_BT-LE(2Mbps)

2478MHz\_Adapter

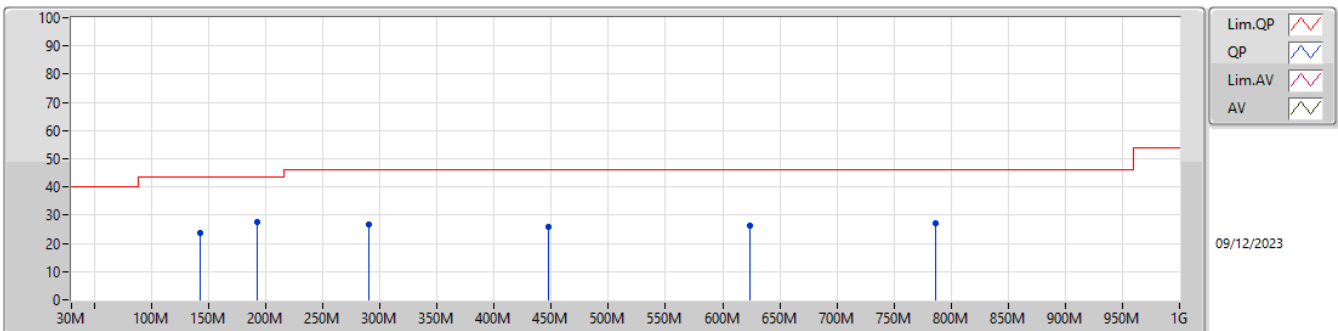

Type	Freq (Hz)	Level (dBuV/m)	Limit (dBuV/m)	Margin (dB)	Factor (dB)	Dist (m)	Condition	Azimuth (°)	Height (m)	Raw (dBuV)	AF (dB)	CL (dB)	PA (dB)
PK	142.52M	23.90	43.50	-19.60	-10.18	3	Horizontal	0	1.00	34.08	16.10	0.89	27.17
PK	192.96M	27.57	43.50	-15.93	-11.71	3	Horizontal	0	1.00	39.28	14.17	1.03	26.91
PK	289.96M	26.63	46.00	-19.37	-7.39	3	Horizontal	0	1.00	34.02	18.09	1.26	26.74
PK	447.11M	25.91	46.00	-20.09	-4.55	3	Horizontal	0	1.00	30.46	21.86	1.56	27.97
PK	623.64M	26.40	46.00	-19.60	-2.60	3	Horizontal	0	1.00	29.00	23.96	1.83	28.39
PK	786.6M	27.10	46.00	-18.90	-1.21	3	Horizontal	0	1.00	28.31	25.05	2.06	28.32

2.4-2.4835GHz\_BT-LE(2Mbps)

2478MHz\_USB

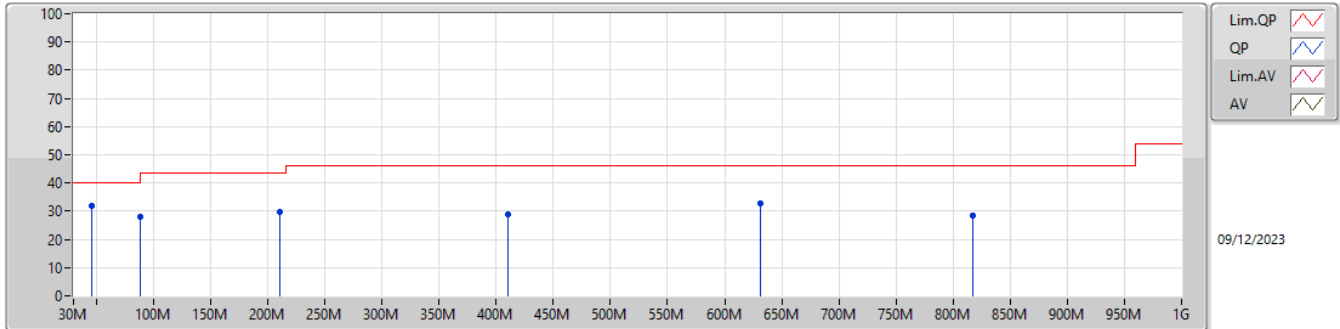

Type	Freq (Hz)	Level (dBuV/m)	Limit (dBuV/m)	Margin (dB)	Factor (dB)	Dist (m)	Condition	Azimuth (°)	Height (m)	Raw (dBuV)	AF (dB)	CL (dB)	PA (dB)
PK	45.52M	31.70	40.00	-8.30	-11.49	3	Vertical	360	1.00	43.19	15.39	0.51	27.39
PK	88.2M	27.98	43.50	-15.52	-12.82	3	Vertical	360	1.00	40.80	13.81	0.70	27.33
PK	210.42M	29.55	43.50	-13.95	-11.55	3	Vertical	360	1.00	41.10	14.21	1.07	26.83
PK	410.24M	29.00	46.00	-17.00	-4.72	3	Vertical	360	1.00	33.72	21.40	1.49	27.61
PK	631.4M	32.82	46.00	-13.18	-2.45	3	Vertical	360	1.00	35.27	24.11	1.84	28.40
PK	817.64M	28.54	46.00	-17.46	-1.17	3	Vertical	360	1.00	29.71	24.93	2.10	28.20

2.4-2.4835GHz\_BT-LE(2Mbps)

2478MHz\_USB

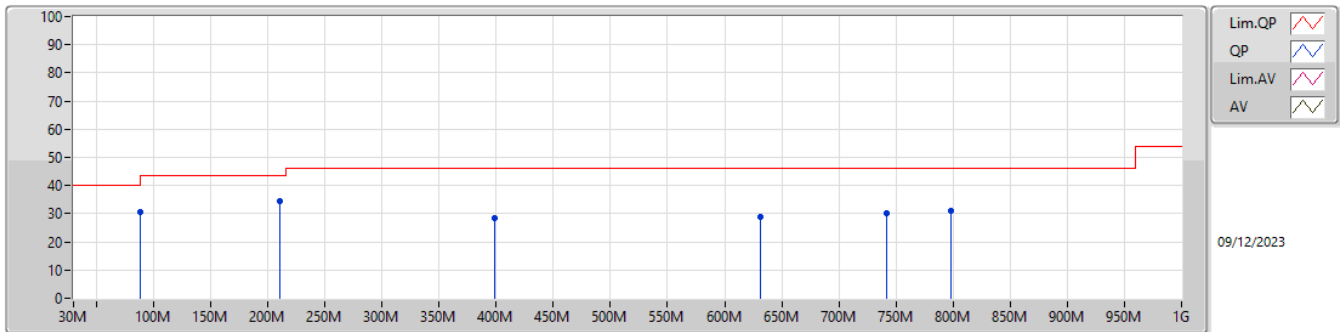

Type	Freq (Hz)	Level (dBuV/m)	Limit (dBuV/m)	Margin (dB)	Factor (dB)	Dist (m)	Condition	Azimuth (°)	Height (m)	Raw (dBuV)	AF (dB)	CL (dB)	PA (dB)
PK	88.2M	30.49	43.50	-13.01	-12.82	3	Horizontal	0	1.00	43.31	13.81	0.70	27.33
PK	210.42M	34.37	43.50	-9.13	-11.55	3	Horizontal	0	1.00	45.92	14.21	1.07	26.83
PK	398.6M	28.25	46.00	-17.75	-5.26	3	Horizontal	0	1.00	33.51	20.77	1.47	27.50
PK	631.4M	28.76	46.00	-17.24	-2.45	3	Horizontal	0	1.00	31.21	24.11	1.84	28.40
PK	741.98M	30.22	46.00	-15.78	-1.77	3	Horizontal	0	1.00	31.99	24.57	2.00	28.34
PK	798.24M	30.86	46.00	-15.14	-1.22	3	Horizontal	0	1.00	32.08	25.01	2.08	28.31



Summary

Mode	Result	Type	Freq (Hz)	Level (dBuV/m)	Limit (dBuV/m)	Margin (dB)	Dist (m)	Condition	Azimuth (°)	Height (m)
2.4-2.4835GHz	-	-	-	-	-	-	-	-	-	-
BT-LE(1Mbps)	Pass	AV	2.4892G	45.58	54.00	-8.42	3	Vertical	223	2.75
BT-LE(2Mbps)	Pass	AV	2.4964G	47.20	54.00	-6.80	3	Vertical	223	3.00





Result

Mode	Result	Type	Freq (Hz)	Level (dBuV/m)	Limit (dBuV/m)	Margin (dB)	Dist (m)	Condition	Azimuth (°)	Height (m)
BT-LE(1Mbps)	-	-	-	-	-	-	-	-	-	-
2402MHz	Pass	AV	2.3742G	44.88	54.00	-9.12	3	Vertical	226	2.81
2402MHz	Pass	AV	2.402G	97.68	Inf	-Inf	3	Vertical	226	2.81
2402MHz	Pass	PK	2.3646G	57.66	74.00	-16.34	3	Vertical	226	2.81
2402MHz	Pass	PK	2.4018G	98.79	Inf	-Inf	3	Vertical	226	2.81
2402MHz	Pass	AV	2.3796G	44.97	54.00	-9.03	3	Horizontal	0	2.17
2402MHz	Pass	AV	2.402G	100.01	Inf	-Inf	3	Horizontal	0	2.17
2402MHz	Pass	PK	2.3702G	56.96	74.00	-17.04	3	Horizontal	0	2.17
2402MHz	Pass	PK	2.4018G	101.09	Inf	-Inf	3	Horizontal	0	2.17
2402MHz	Pass	AV	4.80386G	29.14	54.00	-24.86	3	Vertical	18	2.27
2402MHz	Pass	PK	4.80402G	41.29	74.00	-32.71	3	Vertical	18	2.27
2402MHz	Pass	AV	4.8071G	28.98	54.00	-25.02	3	Horizontal	233	2.88
2402MHz	Pass	PK	4.80808G	40.90	74.00	-33.10	3	Horizontal	233	2.88
2440MHz	Pass	AV	2.3592G	45.07	54.00	-8.93	3	Vertical	223	2.75
2440MHz	Pass	AV	2.44G	96.86	Inf	-Inf	3	Vertical	223	2.75
2440MHz	Pass	AV	2.4892G	45.58	54.00	-8.42	3	Vertical	223	2.75
2440MHz	Pass	PK	2.34G	56.84	74.00	-17.16	3	Vertical	223	2.75
2440MHz	Pass	PK	2.4404G	97.96	Inf	-Inf	3	Vertical	223	2.75
2440MHz	Pass	PK	2.4888G	57.16	74.00	-16.84	3	Vertical	223	2.75
2440MHz	Pass	AV	2.3856G	44.98	54.00	-9.02	3	Horizontal	360	2.75
2440MHz	Pass	AV	2.44G	99.78	Inf	-Inf	3	Horizontal	360	2.75
2440MHz	Pass	AV	2.492G	45.40	54.00	-8.60	3	Horizontal	360	2.75
2440MHz	Pass	PK	2.3516G	57.05	74.00	-16.95	3	Horizontal	360	2.75
2440MHz	Pass	PK	2.4404G	100.88	Inf	-Inf	3	Horizontal	360	2.75
2440MHz	Pass	PK	2.4968G	58.63	74.00	-15.37	3	Horizontal	360	2.75
2440MHz	Pass	AV	4.88082G	29.76	54.00	-24.24	3	Vertical	287	1.53
2440MHz	Pass	PK	4.88486G	42.10	74.00	-31.90	3	Vertical	287	1.53
2440MHz	Pass	AV	4.88478G	29.47	54.00	-24.53	3	Horizontal	272	2.39
2440MHz	Pass	PK	4.87832G	41.90	74.00	-32.10	3	Horizontal	272	2.39
2480MHz	Pass	AV	2.3814G	33.93	54.00	-20.07	3	Vertical	43	1.02
2480MHz	Pass	AV	2.4018G	78.70	Inf	-Inf	3	Vertical	43	1.02
2480MHz	Pass	PK	2.3814G	56.43	74.00	-17.57	3	Vertical	43	1.02
2480MHz	Pass	PK	2.4018G	101.20	Inf	-Inf	3	Vertical	43	1.02
2480MHz	Pass	AV	2.3736G	34.64	54.00	-19.36	3	Horizontal	165	2.18
2480MHz	Pass	AV	2.4018G	82.69	Inf	-Inf	3	Horizontal	165	2.18
2480MHz	Pass	PK	2.3736G	57.14	74.00	-16.86	3	Horizontal	165	2.18
2480MHz	Pass	PK	2.4018G	105.19	Inf	-Inf	3	Horizontal	165	2.18
2480MHz	Pass	AV	4.80272G	18.30	54.00	-35.70	3	Vertical	152	1.44
2480MHz	Pass	PK	4.80692G	40.80	74.00	-33.20	3	Vertical	152	1.44
2480MHz	Pass	AV	4.80164G	19.83	54.00	-34.17	3	Horizontal	262	1.66
2480MHz	Pass	PK	4.80164G	42.33	74.00	-31.67	3	Horizontal	262	1.66
BT-LE(2Mbps)	-	-	-	-	-	-	-	-	-	-
2404MHz	Pass	AV	2.3648G	46.44	54.00	-7.56	3	Vertical	224	2.81
2404MHz	Pass	AV	2.404G	96.12	Inf	-Inf	3	Vertical	224	2.81
2404MHz	Pass	PK	2.3858G	57.77	74.00	-16.23	3	Vertical	224	2.81
2404MHz	Pass	PK	2.4036G	98.53	Inf	-Inf	3	Vertical	224	2.81
2404MHz	Pass	AV	2.3686G	46.50	54.00	-7.50	3	Horizontal	360	2.82
2404MHz	Pass	AV	2.404G	98.35	Inf	-Inf	3	Horizontal	360	2.82
2404MHz	Pass	PK	2.3828G	57.06	74.00	-16.94	3	Horizontal	360	2.82
2404MHz	Pass	PK	2.4034G	100.74	Inf	-Inf	3	Horizontal	360	2.82
2404MHz	Pass	AV	4.80668G	30.90	54.00	-23.10	3	Vertical	153	1.89
2404MHz	Pass	PK	4.80858G	41.55	74.00	-32.45	3	Vertical	153	1.89
2404MHz	Pass	AV	4.8072G	30.72	54.00	-23.28	3	Horizontal	76	1.18
2404MHz	Pass	PK	4.80676G	41.22	74.00	-32.78	3	Horizontal	76	1.18
2440MHz	Pass	AV	2.374G	46.63	54.00	-7.37	3	Vertical	227	2.75
2440MHz	Pass	AV	2.44G	95.54	Inf	-Inf	3	Vertical	227	2.75
2440MHz	Pass	AV	2.4892G	47.06	54.00	-6.94	3	Vertical	227	2.75
2440MHz	Pass	PK	2.3704G	57.17	74.00	-16.83	3	Vertical	227	2.75
2440MHz	Pass	PK	2.4404G	97.92	Inf	-Inf	3	Vertical	227	2.75
2440MHz	Pass	PK	2.498G	57.82	74.00	-16.18	3	Vertical	227	2.75
2440MHz	Pass	AV	2.3712G	46.69	54.00	-7.31	3	Horizontal	360	2.75



**RSE TX above 1GHz\_Right**

**Appendix F.2**

Mode	Result	Type	Freq (Hz)	Level (dBuV/m)	Limit (dBuV/m)	Margin (dB)	Dist (m)	Condition	Azimuth (°)	Height (m)
2440MHz	Pass	AV	2.44G	98.48	Inf	-Inf	3	Horizontal	360	2.75
2440MHz	Pass	AV	2.4968G	46.89	54.00	-7.11	3	Horizontal	360	2.75
2440MHz	Pass	PK	2.3616G	56.87	74.00	-17.13	3	Horizontal	360	2.75
2440MHz	Pass	PK	2.4404G	100.94	Inf	-Inf	3	Horizontal	360	2.75
2440MHz	Pass	PK	2.4984G	57.73	74.00	-16.27	3	Horizontal	360	2.75
2440MHz	Pass	AV	4.88362G	31.01	54.00	-22.99	3	Vertical	73	1.93
2440MHz	Pass	PK	4.88154G	42.37	74.00	-31.63	3	Vertical	73	1.93
2440MHz	Pass	AV	4.88068G	31.09	54.00	-22.91	3	Horizontal	155	2.78
2440MHz	Pass	PK	4.8823G	41.94	74.00	-32.06	3	Horizontal	155	2.78
2478MHz	Pass	AV	2.478G	97.65	Inf	-Inf	3	Vertical	223	3.00
2478MHz	Pass	AV	2.4964G	47.20	54.00	-6.80	3	Vertical	223	3.00
2478MHz	Pass	PK	2.4774G	99.96	Inf	-Inf	3	Vertical	223	3.00
2478MHz	Pass	PK	2.4926G	57.31	74.00	-16.69	3	Vertical	223	3.00
2478MHz	Pass	AV	2.478G	100.15	Inf	-Inf	3	Horizontal	10	2.35
2478MHz	Pass	AV	2.4852G	46.97	54.00	-7.03	3	Horizontal	10	2.35
2478MHz	Pass	PK	2.4786G	102.45	Inf	-Inf	3	Horizontal	10	2.35
2478MHz	Pass	PK	2.4846G	57.47	74.00	-16.53	3	Horizontal	10	2.35
2478MHz	Pass	AV	4.95354G	31.76	54.00	-22.24	3	Vertical	236	2.68
2478MHz	Pass	PK	4.95244G	42.70	74.00	-31.30	3	Vertical	236	2.68
2478MHz	Pass	AV	4.9578G	31.96	54.00	-22.04	3	Horizontal	262	1.06
2478MHz	Pass	PK	4.9531G	42.56	74.00	-31.44	3	Horizontal	262	1.06

2.4-2.4835GHz\_BT-LE(1Mbps)

2402MHz\_TX

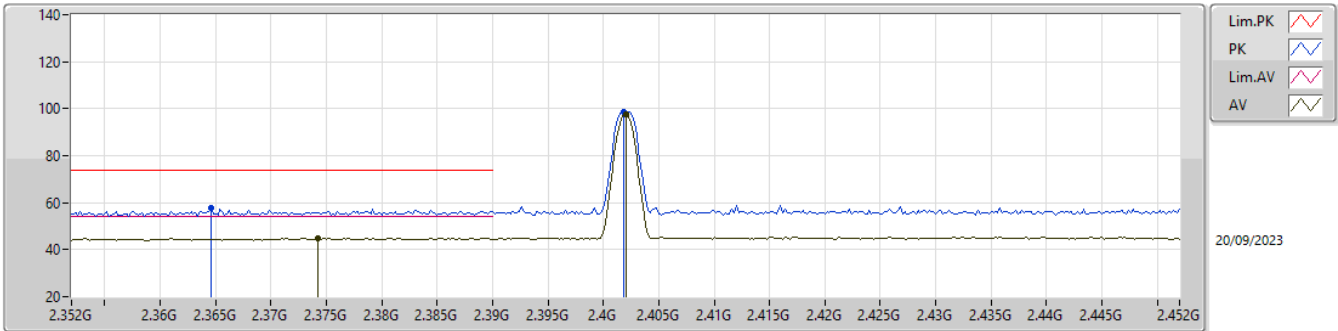

Type	Freq (Hz)	Level (dBuV/m)	Limit (dBuV/m)	Margin (dB)	Factor (dB)	Dist (m)	Condition	Azimuth (°)	Height (m)	Raw (dBuV)	AF (dB)	CL (dB)	PA (dB)
AV	2.3742G	44.88	54.00	-9.12	31.12	3	Vertical	226	2.81	13.76	27.50	3.62	-
AV	2.402G	97.68	Inf	-Inf	31.34	3	Vertical	226	2.81	66.34	27.70	3.64	-
PK	2.3646G	57.66	74.00	-16.34	31.07	3	Vertical	226	2.81	26.59	27.45	3.62	-
PK	2.4018G	98.79	Inf	-Inf	31.34	3	Vertical	226	2.81	67.45	27.70	3.64	-

2.4-2.4835GHz\_BT-LE(1Mbps)

2402MHz\_TX

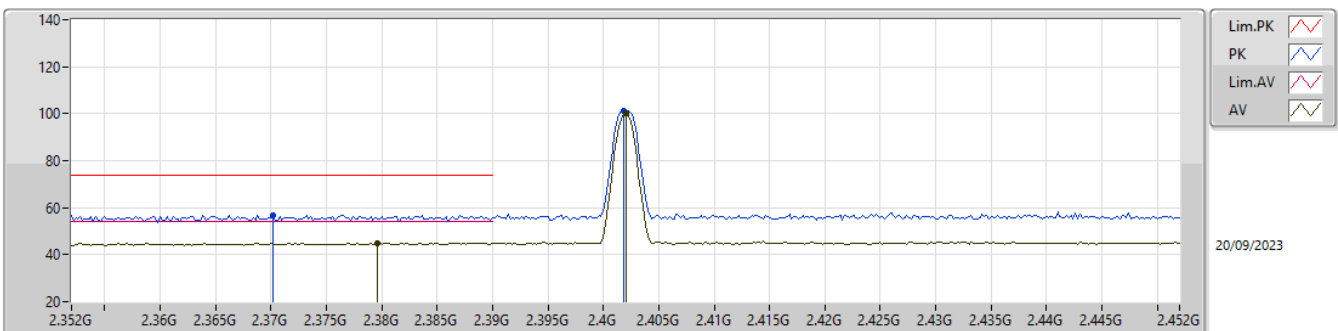

Type	Freq (Hz)	Level (dBuV/m)	Limit (dBuV/m)	Margin (dB)	Factor (dB)	Dist (m)	Condition	Azimuth (°)	Height (m)	Raw (dBuV)	AF (dB)	CL (dB)	PA (dB)
AV	2.3796G	44.97	54.00	-9.03	31.13	3	Horizontal	0	2.17	13.84	27.50	3.63	-
AV	2.402G	100.01	Inf	-Inf	31.34	3	Horizontal	0	2.17	68.67	27.70	3.64	-
PK	2.3702G	56.96	74.00	-17.04	31.12	3	Horizontal	0	2.17	25.84	27.50	3.62	-
PK	2.4018G	101.09	Inf	-Inf	31.34	3	Horizontal	0	2.17	69.75	27.70	3.64	-

2.4-2.4835GHz\_BT-LE(1Mbps)

2402MHz\_TX

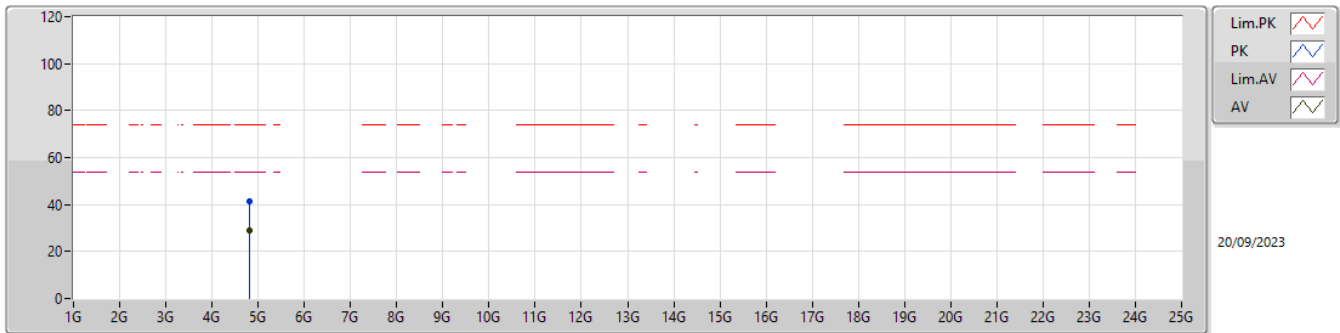

Type	Freq (Hz)	Level (dBuV/m)	Limit (dBuV/m)	Margin (dB)	Factor (dB)	Dist (m)	Condition	Azimuth (°)	Height (m)	Raw (dBuV)	AF (dB)	CL (dB)	PA (dB)
AV	4.80386G	29.14	54.00	-24.86	0.39	3	Vertical	18	2.27	28.75	32.52	5.29	37.42
PK	4.80402G	41.29	74.00	-32.71	0.39	3	Vertical	18	2.27	40.90	32.52	5.29	37.42

2.4-2.4835GHz\_BT-LE(1Mbps)

2402MHz\_TX

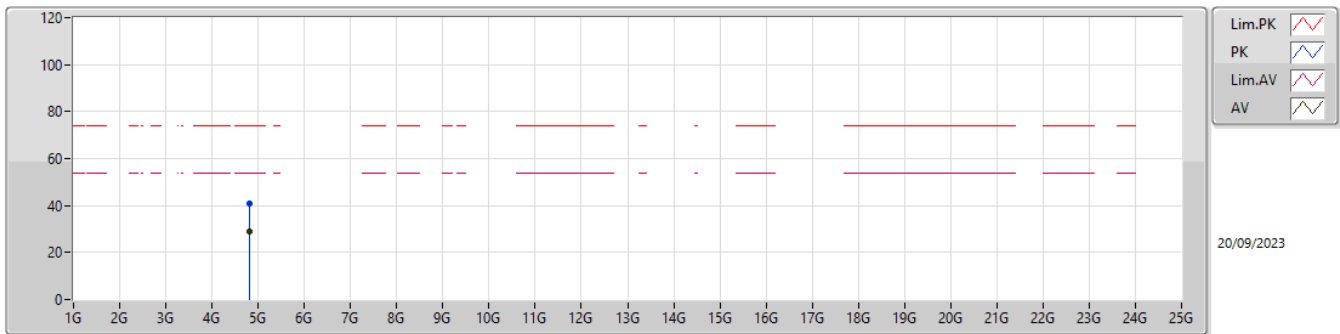

Type	Freq (Hz)	Level (dBuV/m)	Limit (dBuV/m)	Margin (dB)	Factor (dB)	Dist (m)	Condition	Azimuth (°)	Height (m)	Raw (dBuV)	AF (dB)	CL (dB)	PA (dB)
AV	4.8071G	28.98	54.00	-25.02	0.41	3	Horizontal	233	2.88	28.57	32.54	5.29	37.42
PK	4.80808G	40.90	74.00	-33.10	0.43	3	Horizontal	233	2.88	40.47	32.55	5.29	37.41

2.4-2.4835GHz\_BT-LE(1Mbps)

2440MHz\_TX

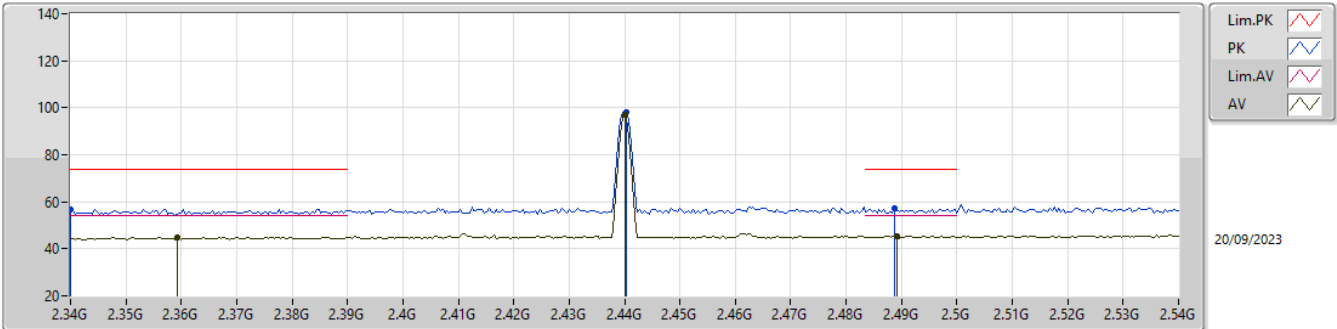

Type	Freq (Hz)	Level (dBuV/m)	Limit (dBuV/m)	Margin (dB)	Factor (dB)	Dist (m)	Condition	Azimuth (°)	Height (m)	Raw (dBuV)	AF (dB)	CL (dB)	PA (dB)
AV	2.3592G	45.07	54.00	-8.93	31.01	3	Vertical	223	2.75	14.06	27.40	3.61	-
AV	2.44G	96.86	Inf	-Inf	31.37	3	Vertical	223	2.75	65.49	27.70	3.67	-
AV	2.4892G	45.58	54.00	-8.42	31.51	3	Vertical	223	2.75	14.07	27.80	3.71	-
PK	2.34G	56.84	74.00	-17.16	30.90	3	Vertical	223	2.75	25.94	27.30	3.60	-
PK	2.4404G	97.96	Inf	-Inf	31.37	3	Vertical	223	2.75	66.59	27.70	3.67	-
PK	2.4888G	57.16	74.00	-16.84	31.51	3	Vertical	223	2.75	25.65	27.80	3.71	-

2.4-2.4835GHz\_BT-LE(1Mbps)

2440MHz\_TX

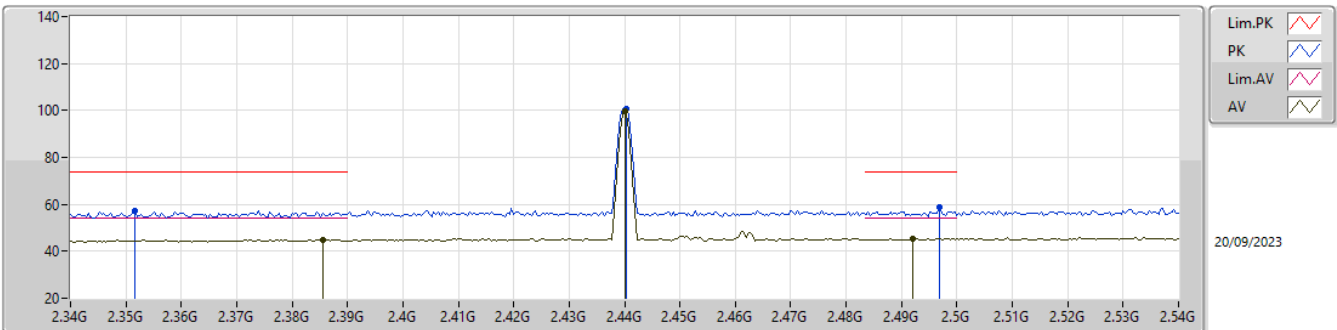

Type	Freq (Hz)	Level (dBuV/m)	Limit (dBuV/m)	Margin (dB)	Factor (dB)	Dist (m)	Condition	Azimuth (°)	Height (m)	Raw (dBuV)	AF (dB)	CL (dB)	PA (dB)
AV	2.3856G	44.98	54.00	-9.02	31.19	3	Horizontal	360	2.75	13.79	27.56	3.63	-
AV	2.44G	99.78	Inf	-Inf	31.37	3	Horizontal	360	2.75	68.41	27.70	3.67	-
AV	2.492G	45.40	54.00	-8.60	31.51	3	Horizontal	360	2.75	13.89	27.80	3.71	-
PK	2.3516G	57.05	74.00	-16.95	31.01	3	Horizontal	360	2.75	26.04	27.40	3.61	-
PK	2.4404G	100.88	Inf	-Inf	31.37	3	Horizontal	360	2.75	69.51	27.70	3.67	-
PK	2.4968G	58.63	74.00	-15.37	31.52	3	Horizontal	360	2.75	27.11	27.80	3.72	-

2.4-2.4835GHz\_BT-LE(1Mbps)

2440MHz\_TX

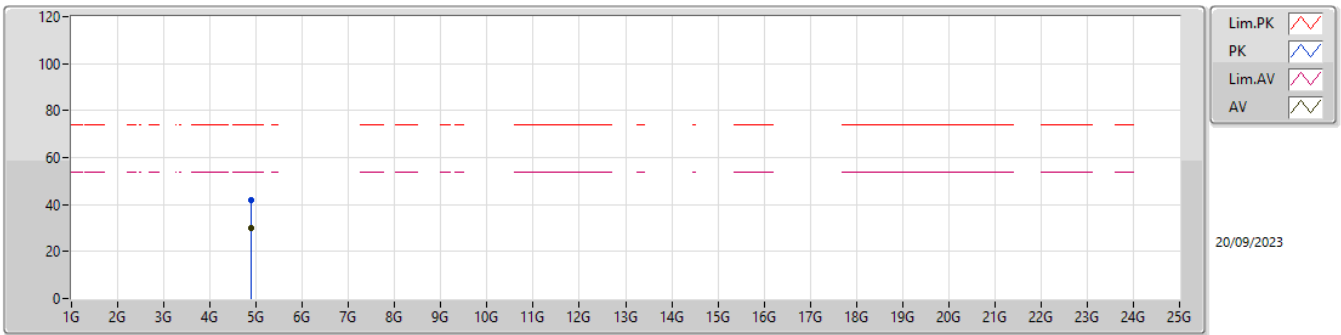

Type	Freq (Hz)	Level (dBuV/m)	Limit (dBuV/m)	Margin (dB)	Factor (dB)	Dist (m)	Condition	Azimuth (°)	Height (m)	Raw (dBuV)	AF (dB)	CL (dB)	PA (dB)
AV	4.88082G	29.76	54.00	-24.24	0.80	3	Vertical	287	1.53	28.96	32.80	5.33	37.33
PK	4.88486G	42.10	74.00	-31.90	0.80	3	Vertical	287	1.53	41.30	32.80	5.33	37.33

2.4-2.4835GHz\_BT-LE(1Mbps)

2440MHz\_TX

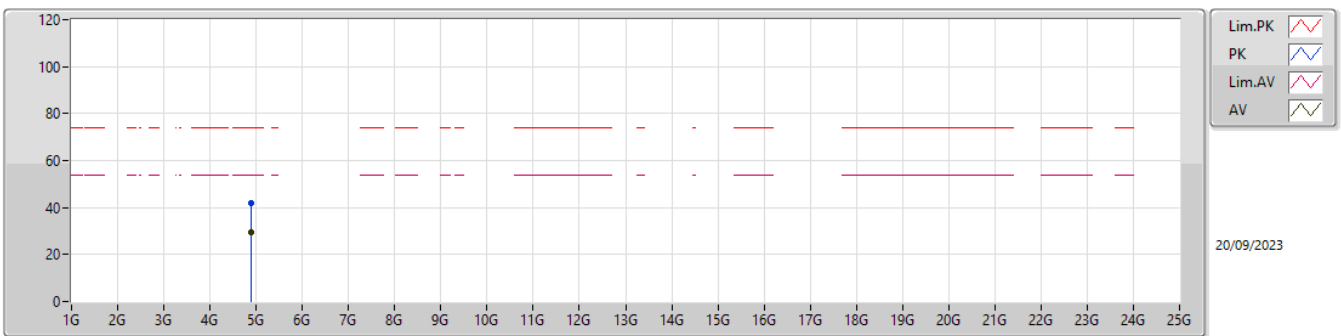

Type	Freq (Hz)	Level (dBuV/m)	Limit (dBuV/m)	Margin (dB)	Factor (dB)	Dist (m)	Condition	Azimuth (°)	Height (m)	Raw (dBuV)	AF (dB)	CL (dB)	PA (dB)
AV	4.88478G	29.47	54.00	-24.53	0.80	3	Horizontal	272	2.39	28.67	32.80	5.33	37.33
PK	4.87832G	41.90	74.00	-32.10	0.79	3	Horizontal	272	2.39	41.11	32.80	5.33	37.34

2.4-2.4835GHz\_BT-LE(1Mbps)

2480MHz\_TX

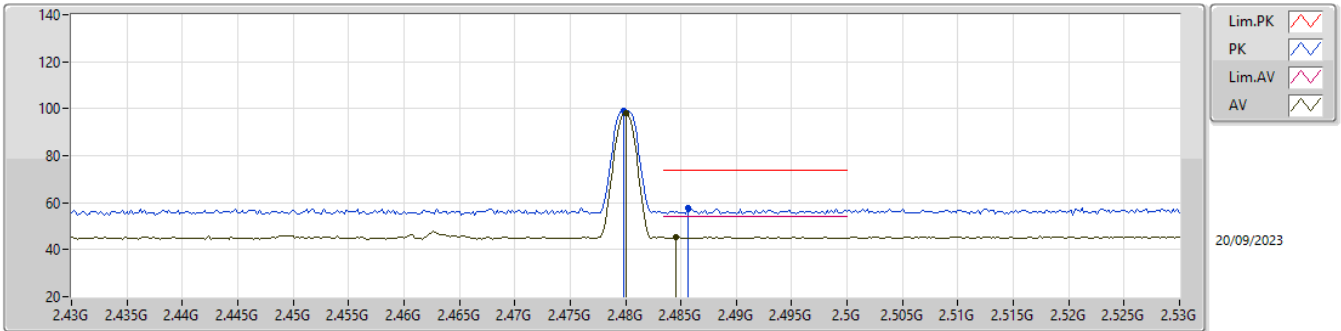

Type	Freq (Hz)	Level (dBuV/m)	Limit (dBuV/m)	Margin (dB)	Factor (dB)	Dist (m)	Condition	Azimuth (°)	Height (m)	Raw (dBuV)	AF (dB)	CL (dB)	PA (dB)
AV	2.48G	98.05	Inf	-Inf	31.50	3	Vertical	223	3.00	66.55	27.80	3.70	-
AV	2.4846G	45.38	54.00	-8.62	31.51	3	Vertical	223	3.00	13.87	27.80	3.71	-
PK	2.4798G	99.25	Inf	-Inf	31.50	3	Vertical	223	3.00	67.75	27.80	3.70	-
PK	2.4856G	57.52	74.00	-16.48	31.51	3	Vertical	223	3.00	26.01	27.80	3.71	-

2.4-2.4835GHz\_BT-LE(1Mbps)

2480MHz\_TX

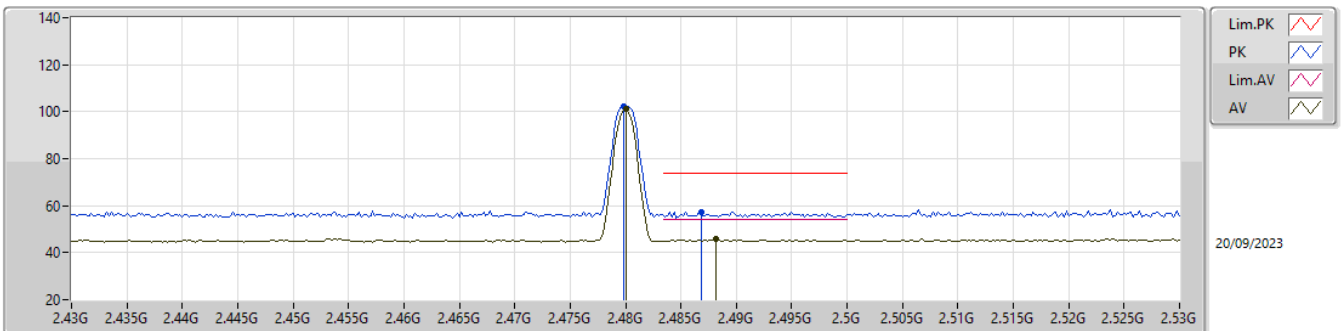

Type	Freq (Hz)	Level (dBuV/m)	Limit (dBuV/m)	Margin (dB)	Factor (dB)	Dist (m)	Condition	Azimuth (°)	Height (m)	Raw (dBuV)	AF (dB)	CL (dB)	PA (dB)
AV	2.48G	101.09	Inf	-Inf	31.50	3	Horizontal	10	2.63	69.59	27.80	3.70	-
AV	2.4882G	45.61	54.00	-8.39	31.51	3	Horizontal	10	2.63	14.10	27.80	3.71	-
PK	2.4798G	102.25	Inf	-Inf	31.50	3	Horizontal	10	2.63	70.75	27.80	3.70	-
PK	2.4868G	57.27	74.00	-16.73	31.51	3	Horizontal	10	2.63	25.76	27.80	3.71	-

2.4-2.4835GHz\_BT-LE(1Mbps)

2480MHz\_TX

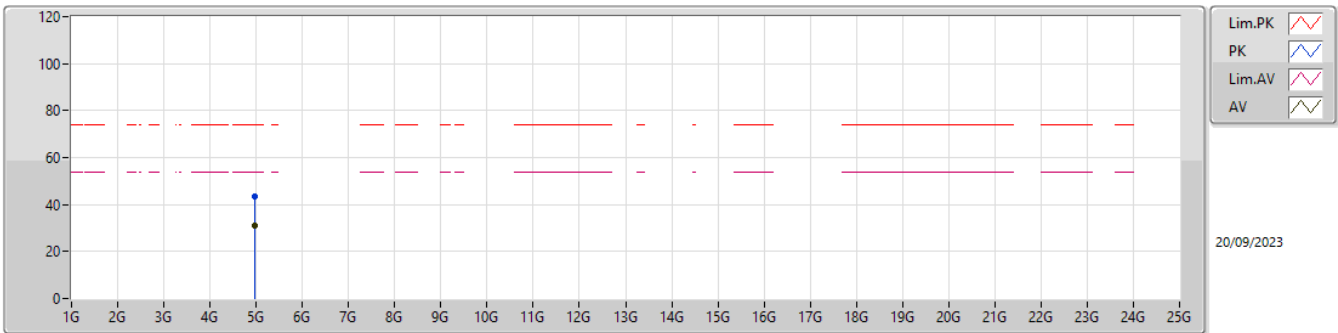

Type	Freq (Hz)	Level (dBuV/m)	Limit (dBuV/m)	Margin (dB)	Factor (dB)	Dist (m)	Condition	Azimuth (°)	Height (m)	Raw (dBuV)	AF (dB)	CL (dB)	PA (dB)
AV	4.96454G	30.93	54.00	-23.07	1.31	3	Vertical	250	2.93	29.62	33.19	5.36	37.24
PK	4.95934G	43.23	74.00	-30.77	1.27	3	Vertical	250	2.93	41.96	33.16	5.36	37.25

2.4-2.4835GHz\_BT-LE(1Mbps)

2480MHz\_TX

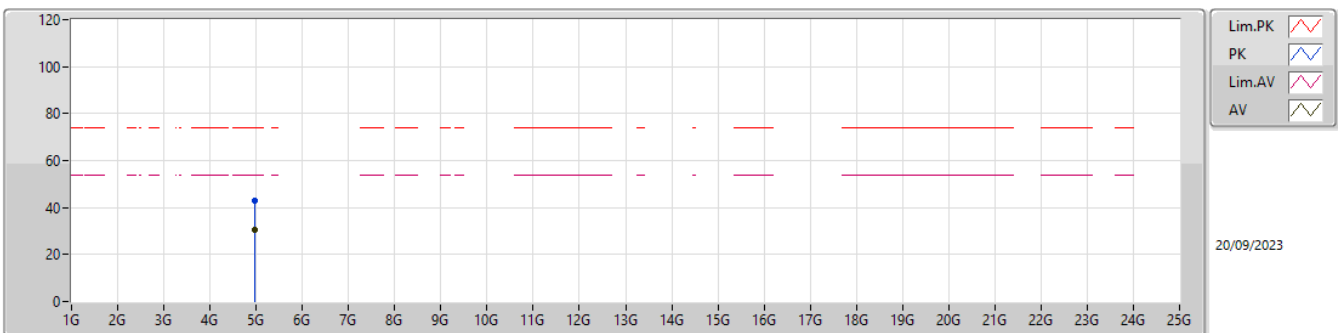

Type	Freq (Hz)	Level (dBuV/m)	Limit (dBuV/m)	Margin (dB)	Factor (dB)	Dist (m)	Condition	Azimuth (°)	Height (m)	Raw (dBuV)	AF (dB)	CL (dB)	PA (dB)
AV	4.96162G	30.59	54.00	-23.41	1.29	3	Horizontal	48	1.15	29.30	33.17	5.36	37.24
PK	4.96366G	42.80	74.00	-31.20	1.30	3	Horizontal	48	1.15	41.50	33.18	5.36	37.24



2.4-2.4835GHz\_BT-LE(2Mbps)

2404MHz\_TX

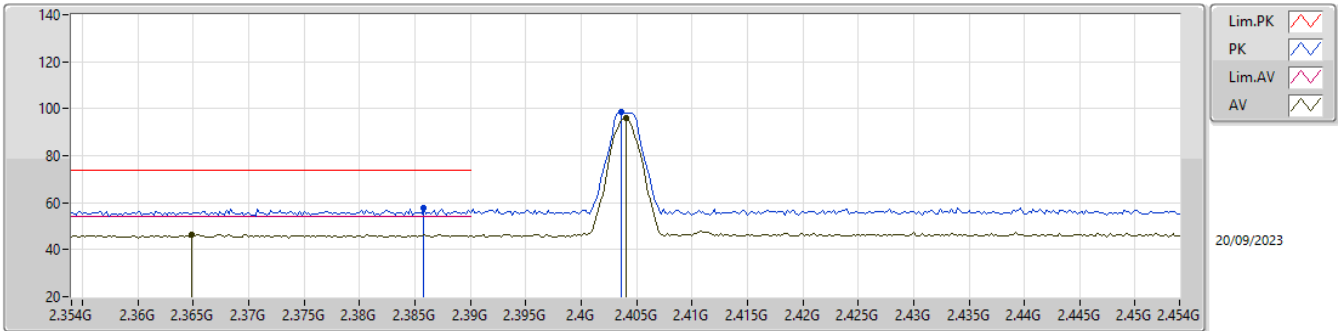

Type	Freq (Hz)	Level (dBuV/m)	Limit (dBuV/m)	Margin (dB)	Factor (dB)	Dist (m)	Condition	Azimuth (°)	Height (m)	Raw (dBuV)	AF (dB)	CL (dB)	PA (dB)
AV	2.3648G	46.44	54.00	-7.56	31.07	3	Vertical	224	2.81	15.37	27.45	3.62	-
AV	2.404G	96.12	Inf	-Inf	31.34	3	Vertical	224	2.81	64.78	27.70	3.64	-
PK	2.3858G	57.77	74.00	-16.23	31.19	3	Vertical	224	2.81	26.58	27.56	3.63	-
PK	2.4036G	98.53	Inf	-Inf	31.34	3	Vertical	224	2.81	67.19	27.70	3.64	-

2.4-2.4835GHz\_BT-LE(2Mbps)

2404MHz\_TX

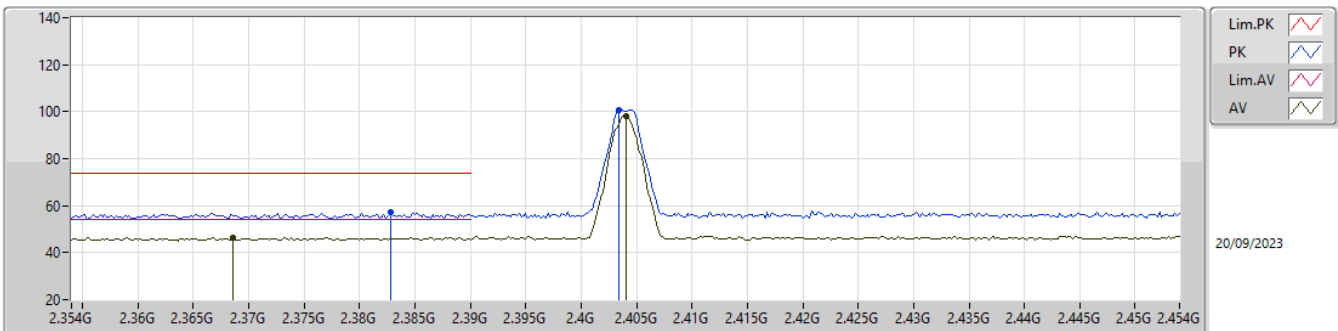

Type	Freq (Hz)	Level (dBuV/m)	Limit (dBuV/m)	Margin (dB)	Factor (dB)	Dist (m)	Condition	Azimuth (°)	Height (m)	Raw (dBuV)	AF (dB)	CL (dB)	PA (dB)
AV	2.3686G	46.50	54.00	-7.50	31.11	3	Horizontal	360	2.82	15.39	27.49	3.62	-
AV	2.404G	98.35	Inf	-Inf	31.34	3	Horizontal	360	2.82	67.01	27.70	3.64	-
PK	2.3828G	57.06	74.00	-16.94	31.16	3	Horizontal	360	2.82	25.90	27.53	3.63	-
PK	2.4034G	100.74	Inf	-Inf	31.34	3	Horizontal	360	2.82	69.40	27.70	3.64	-

2.4-2.4835GHz\_BT-LE(2Mbps)

2404MHz\_TX

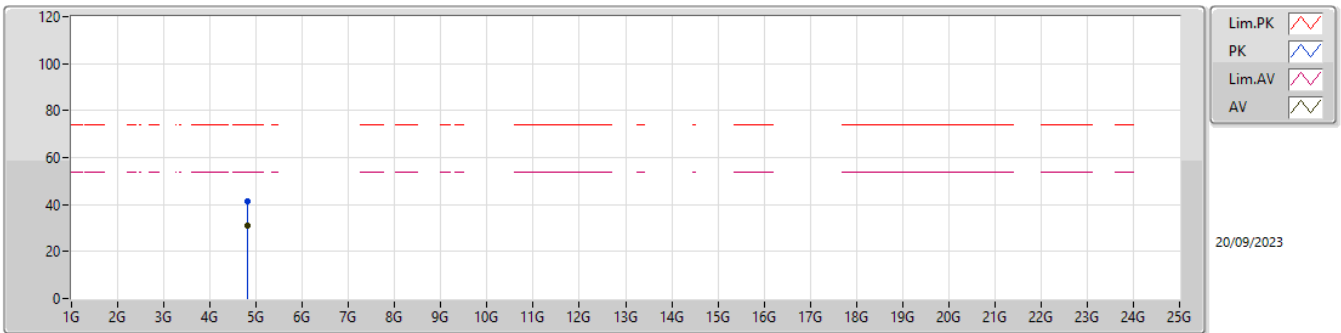

Type	Freq (Hz)	Level (dBuV/m)	Limit (dBuV/m)	Margin (dB)	Factor (dB)	Dist (m)	Condition	Azimuth (°)	Height (m)	Raw (dBuV)	AF (dB)	CL (dB)	PA (dB)
AV	4.80668G	30.90	54.00	-23.10	0.41	3	Vertical	153	1.89	30.49	32.54	5.29	37.42
PK	4.80658G	41.55	74.00	-32.45	0.43	3	Vertical	153	1.89	41.12	32.55	5.29	37.41

2.4-2.4835GHz\_BT-LE(2Mbps)

2404MHz\_TX

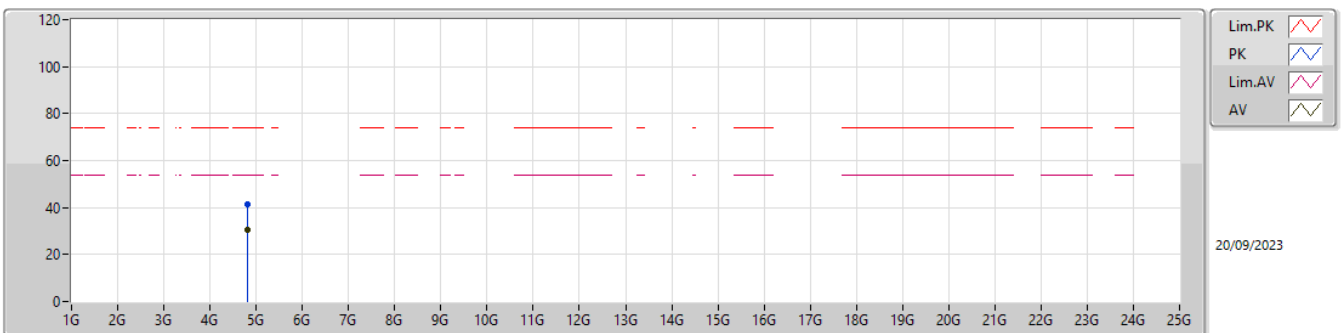

Type	Freq (Hz)	Level (dBuV/m)	Limit (dBuV/m)	Margin (dB)	Factor (dB)	Dist (m)	Condition	Azimuth (°)	Height (m)	Raw (dBuV)	AF (dB)	CL (dB)	PA (dB)
AV	4.8072G	30.72	54.00	-23.28	0.41	3	Horizontal	76	1.18	30.31	32.54	5.29	37.42
PK	4.80676G	41.22	74.00	-32.78	0.41	3	Horizontal	76	1.18	40.81	32.54	5.29	37.42

2.4-2.4835GHz\_BT-LE(2Mbps)

2440MHz\_TX

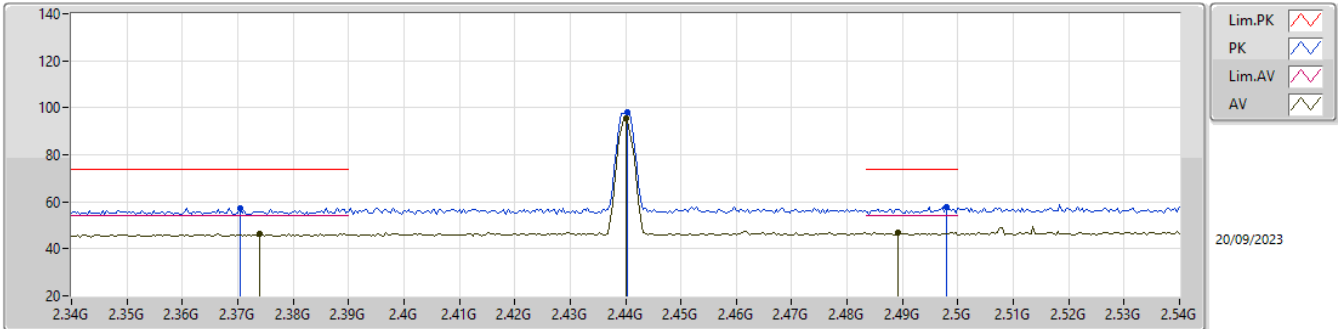

Type	Freq (Hz)	Level (dBuV/m)	Limit (dBuV/m)	Margin (dB)	Factor (dB)	Dist (m)	Condition	Azimuth (°)	Height (m)	Raw (dBuV)	AF (dB)	CL (dB)	PA (dB)
AV	2.374G	46.63	54.00	-7.37	31.12	3	Vertical	227	2.75	15.51	27.50	3.62	-
AV	2.44G	95.54	Inf	-Inf	31.37	3	Vertical	227	2.75	64.17	27.70	3.67	-
AV	2.4892G	47.06	54.00	-6.94	31.51	3	Vertical	227	2.75	15.55	27.80	3.71	-
PK	2.3704G	57.17	74.00	-16.83	31.12	3	Vertical	227	2.75	26.05	27.50	3.62	-
PK	2.4404G	97.92	Inf	-Inf	31.37	3	Vertical	227	2.75	66.55	27.70	3.67	-
PK	2.498G	57.82	74.00	-16.18	31.52	3	Vertical	227	2.75	26.30	27.80	3.72	-

2.4-2.4835GHz\_BT-LE(2Mbps)

2440MHz\_TX

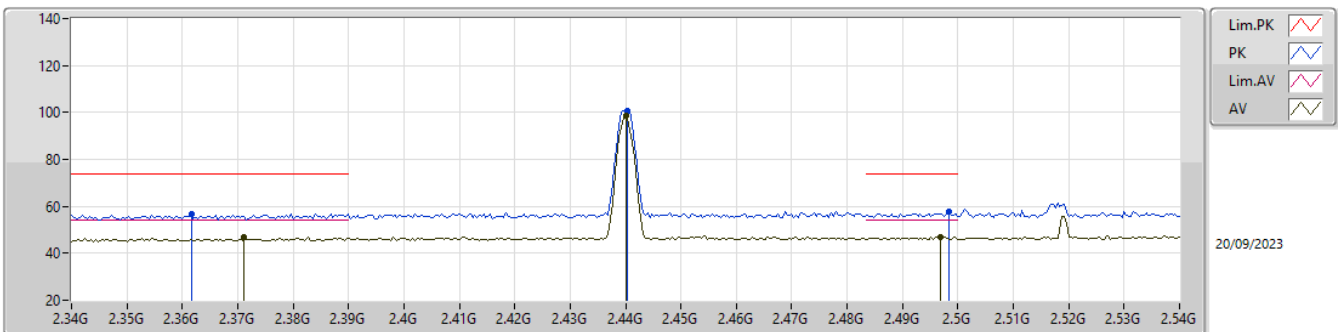

Type	Freq (Hz)	Level (dBuV/m)	Limit (dBuV/m)	Margin (dB)	Factor (dB)	Dist (m)	Condition	Azimuth (°)	Height (m)	Raw (dBuV)	AF (dB)	CL (dB)	PA (dB)
AV	2.3712G	46.69	54.00	-7.31	31.12	3	Horizontal	360	2.75	15.57	27.50	3.62	-
AV	2.44G	98.48	Inf	-Inf	31.37	3	Horizontal	360	2.75	67.11	27.70	3.67	-
AV	2.4968G	46.89	54.00	-7.11	31.52	3	Horizontal	360	2.75	15.37	27.80	3.72	-
PK	2.3616G	56.87	74.00	-17.13	31.03	3	Horizontal	360	2.75	25.84	27.42	3.61	-
PK	2.4404G	100.94	Inf	-Inf	31.37	3	Horizontal	360	2.75	69.57	27.70	3.67	-
PK	2.4984G	57.73	74.00	-16.27	31.52	3	Horizontal	360	2.75	26.21	27.80	3.72	-

2.4-2.4835GHz\_BT-LE(2Mbps)

2440MHz\_TX

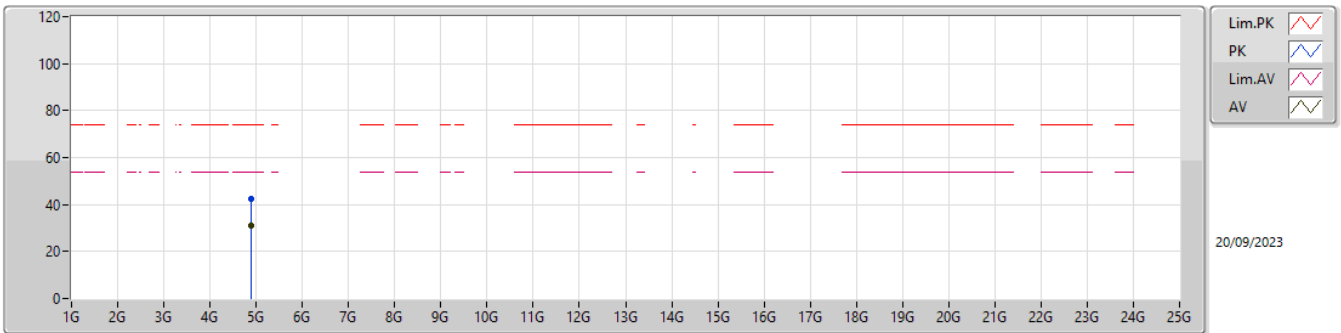

Type	Freq (Hz)	Level (dBuV/m)	Limit (dBuV/m)	Margin (dB)	Factor (dB)	Dist (m)	Condition	Azimuth (°)	Height (m)	Raw (dBuV)	AF (dB)	CL (dB)	PA (dB)
AV	4.88362G	31.01	54.00	-22.99	0.80	3	Vertical	73	1.93	30.21	32.80	5.33	37.33
PK	4.88154G	42.37	74.00	-31.63	0.80	3	Vertical	73	1.93	41.57	32.80	5.33	37.33

2.4-2.4835GHz\_BT-LE(2Mbps)

2440MHz\_TX

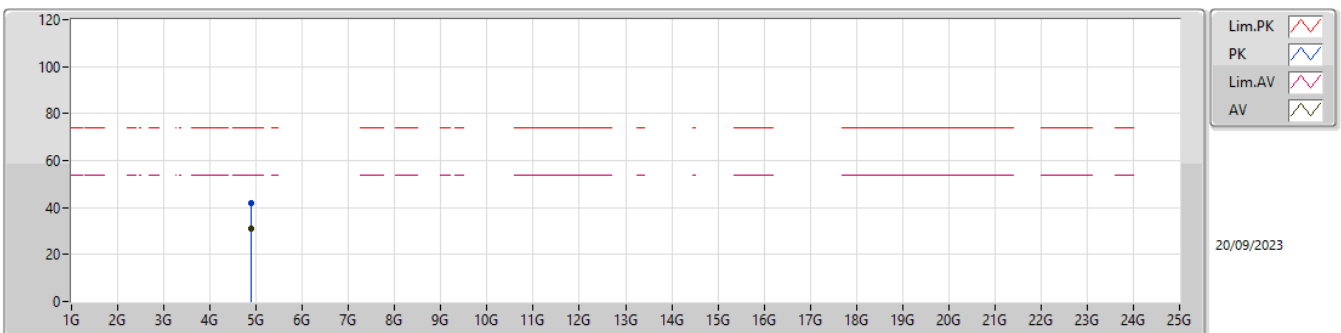

Type	Freq (Hz)	Level (dBuV/m)	Limit (dBuV/m)	Margin (dB)	Factor (dB)	Dist (m)	Condition	Azimuth (°)	Height (m)	Raw (dBuV)	AF (dB)	CL (dB)	PA (dB)
AV	4.88068G	31.09	54.00	-22.91	0.80	3	Horizontal	155	2.78	30.29	32.80	5.33	37.33
PK	4.8823G	41.94	74.00	-32.06	0.80	3	Horizontal	155	2.78	41.14	32.80	5.33	37.33

2.4-2.4835GHz\_BT-LE(2Mbps)

2478MHz\_TX

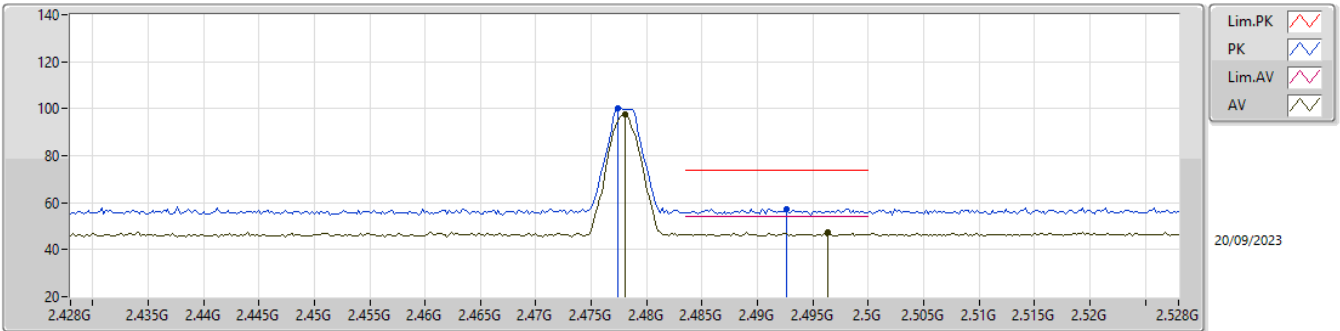

Type	Freq (Hz)	Level (dBuV/m)	Limit (dBuV/m)	Margin (dB)	Factor (dB)	Dist (m)	Condition	Azimuth (°)	Height (m)	Raw (dBuV)	AF (dB)	CL (dB)	PA (dB)
AV	2.478G	97.65	Inf	-Inf	31.48	3	Vertical	223	3.00	66.17	27.78	3.70	-
AV	2.4964G	47.20	54.00	-6.80	31.52	3	Vertical	223	3.00	15.68	27.80	3.72	-
PK	2.4774G	99.96	Inf	-Inf	31.47	3	Vertical	223	3.00	68.49	27.77	3.70	-
PK	2.4926G	57.31	74.00	-16.69	31.51	3	Vertical	223	3.00	25.80	27.80	3.71	-

2.4-2.4835GHz\_BT-LE(2Mbps)

2478MHz\_TX

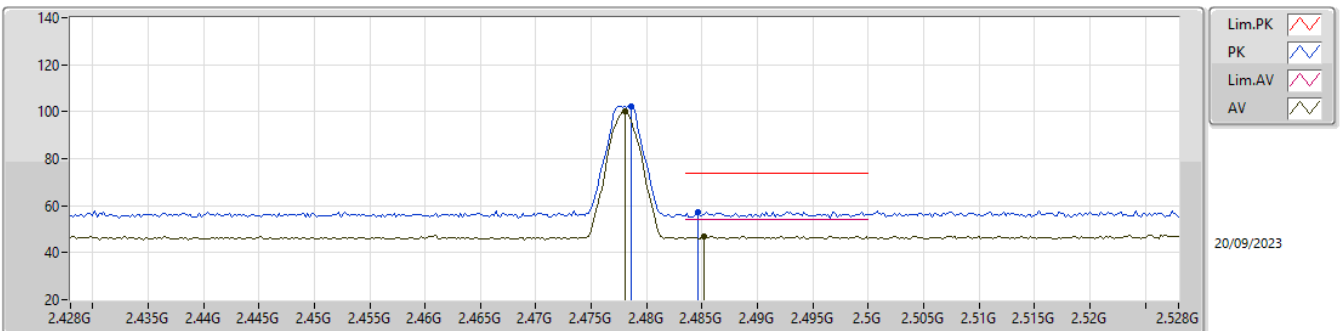

Type	Freq (Hz)	Level (dBuV/m)	Limit (dBuV/m)	Margin (dB)	Factor (dB)	Dist (m)	Condition	Azimuth (°)	Height (m)	Raw (dBuV)	AF (dB)	CL (dB)	PA (dB)
AV	2.478G	100.15	Inf	-Inf	31.48	3	Horizontal	10	2.35	68.67	27.78	3.70	-
AV	2.4852G	46.97	54.00	-7.03	31.51	3	Horizontal	10	2.35	15.46	27.80	3.71	-
PK	2.4786G	102.45	Inf	-Inf	31.49	3	Horizontal	10	2.35	70.96	27.79	3.70	-
PK	2.4846G	57.47	74.00	-16.53	31.51	3	Horizontal	10	2.35	25.96	27.80	3.71	-

2.4-2.4835GHz\_BT-LE(2Mbps)

2478MHz\_TX

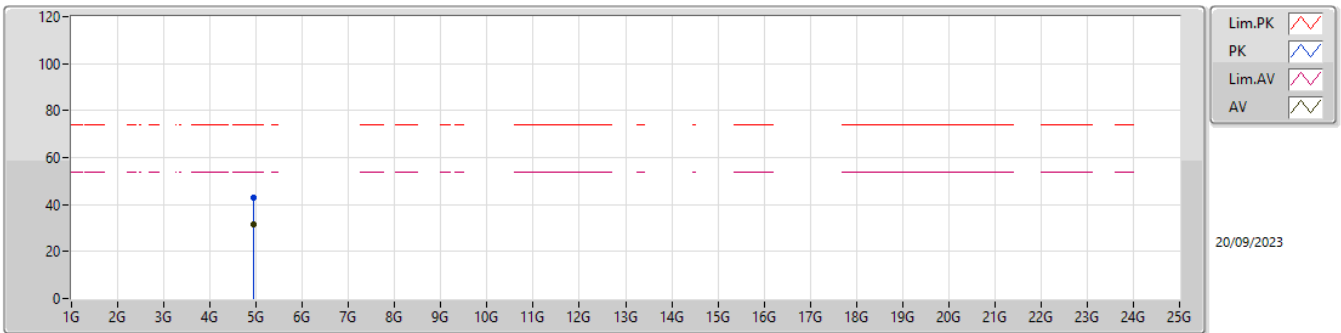

Type	Freq (Hz)	Level (dBuV/m)	Limit (dBuV/m)	Margin (dB)	Factor (dB)	Dist (m)	Condition	Azimuth (°)	Height (m)	Raw (dBuV)	AF (dB)	CL (dB)	PA (dB)
AV	4.95354G	31.76	54.00	-22.24	1.23	3	Vertical	236	2.68	30.53	33.12	5.36	37.25
PK	4.95244G	42.70	74.00	-31.30	1.22	3	Vertical	236	2.68	41.48	33.11	5.36	37.25

2.4-2.4835GHz\_BT-LE(2Mbps)

2478MHz\_TX

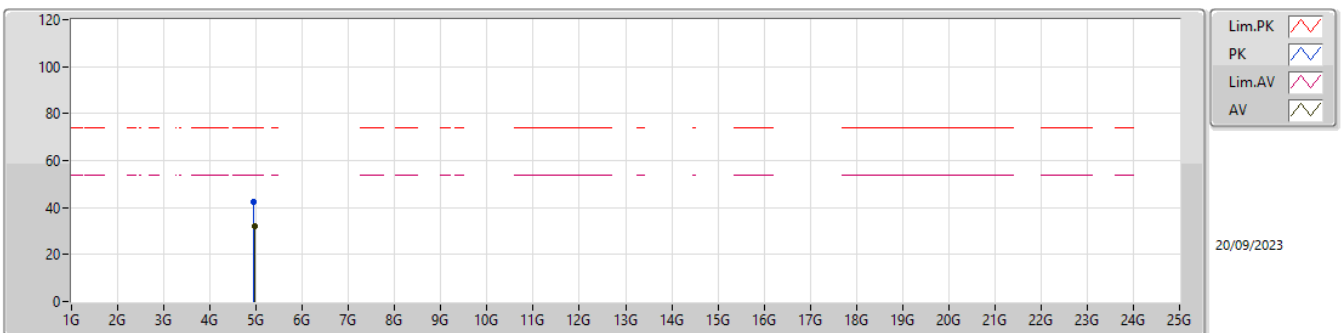

Type	Freq (Hz)	Level (dBuV/m)	Limit (dBuV/m)	Margin (dB)	Factor (dB)	Dist (m)	Condition	Azimuth (°)	Height (m)	Raw (dBuV)	AF (dB)	CL (dB)	PA (dB)
AV	4.9578G	31.96	54.00	-22.04	1.26	3	Horizontal	262	1.06	30.70	33.15	5.36	37.25
PK	4.9531G	42.56	74.00	-31.44	1.23	3	Horizontal	262	1.06	41.33	33.12	5.36	37.25



Summary

Mode	Result	Type	Freq (Hz)	Level (dBuV/m)	Limit (dBuV/m)	Margin (dB)	Dist (m)	Condition	Azimuth (°)	Height (m)
2.4-2.4835GHz	-	-	-	-	-	-	-	-	-	-
BT-LE(2Mbps)	Pass	PK	45.52M	34.34	40.00	-5.66	3	Vertical	360	1.00



Result

Mode	Result	Type	Freq (Hz)	Level (dBuV/m)	Limit (dBuV/m)	Margin (dB)	Dist (m)	Condition	Azimuth (°)	Height (m)
BT-LE(2Mbps)	-	-	-	-	-	-	-	-	-	-
2478MHz	Pass	PK	119.24M	23.72	43.50	-19.78	3	Vertical	360	1.00
2478MHz	Pass	PK	241.46M	24.08	46.00	-21.92	3	Vertical	360	1.00
2478MHz	Pass	PK	289.96M	24.80	46.00	-21.20	3	Vertical	360	1.00
2478MHz	Pass	PK	398.6M	25.69	46.00	-20.31	3	Vertical	360	1.00
2478MHz	Pass	PK	458.74M	26.48	46.00	-19.52	3	Vertical	360	1.00
2478MHz	Pass	PK	848.68M	27.78	46.00	-18.22	3	Vertical	360	1.00
2478MHz	Pass	PK	192.96M	28.76	43.50	-14.74	3	Horizontal	0	1.00
2478MHz	Pass	PK	241.46M	26.56	46.00	-19.44	3	Horizontal	0	1.00
2478MHz	Pass	PK	326.82M	26.63	46.00	-19.37	3	Horizontal	0	1.00
2478MHz	Pass	PK	458.74M	26.28	46.00	-19.72	3	Horizontal	0	1.00
2478MHz	Pass	PK	617.82M	26.22	46.00	-19.78	3	Horizontal	0	1.00
2478MHz	Pass	PK	854.5M	27.93	46.00	-18.07	3	Horizontal	0	1.00
2478MHz	Pass	PK	45.52M	34.34	40.00	-5.66	3	Vertical	360	1.00
2478MHz	Pass	PK	88.2M	29.58	43.50	-13.92	3	Vertical	360	1.00
2478MHz	Pass	PK	210.42M	30.24	43.50	-13.26	3	Vertical	360	1.00
2478MHz	Pass	PK	253.1M	31.38	46.00	-14.62	3	Vertical	360	1.00
2478MHz	Pass	PK	332.64M	29.72	46.00	-16.28	3	Vertical	360	1.00
2478MHz	Pass	PK	631.4M	33.30	46.00	-12.70	3	Vertical	360	1.00
2478MHz	Pass	PK	90.14M	31.02	43.50	-12.48	3	Horizontal	0	1.00
2478MHz	Pass	PK	210.42M	34.88	43.50	-8.62	3	Horizontal	0	1.00
2478MHz	Pass	PK	408.3M	29.02	46.00	-16.98	3	Horizontal	0	1.00
2478MHz	Pass	PK	631.4M	29.19	46.00	-16.81	3	Horizontal	0	1.00
2478MHz	Pass	PK	718.7M	37.74	46.00	-8.26	3	Horizontal	0	1.00
2478MHz	Pass	PK	796.3M	35.22	46.00	-10.78	3	Horizontal	0	1.00



2.4-2.4835GHz\_BT-LE(2Mbps)

2478MHz\_Adapter

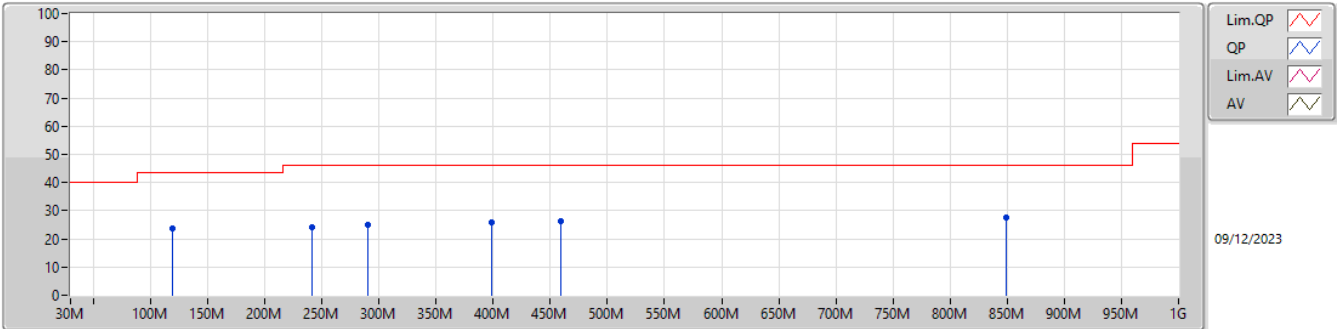

Type	Freq (Hz)	Level (dBuV/m)	Limit (dBuV/m)	Margin (dB)	Factor (dB)	Dist (m)	Condition	Azimuth (°)	Height (m)	Raw (dBuV)	AF (dB)	CL (dB)	PA (dB)
PK	119.24M	23.72	43.50	-19.78	-9.31	3	Vertical	360	1.00	33.03	17.11	0.82	27.24
PK	241.46M	24.08	46.00	-21.92	-9.03	3	Vertical	360	1.00	33.11	16.57	1.14	26.74
PK	289.96M	24.80	46.00	-21.20	-7.39	3	Vertical	360	1.00	32.19	18.09	1.26	26.74
PK	398.6M	25.69	46.00	-20.31	-5.26	3	Vertical	360	1.00	30.95	20.77	1.47	27.50
PK	458.74M	26.48	46.00	-19.52	-4.34	3	Vertical	360	1.00	30.82	22.11	1.58	28.03
PK	848.68M	27.78	46.00	-18.22	-0.58	3	Vertical	360	1.00	28.36	25.28	2.15	28.01

2.4-2.4835GHz\_BT-LE(2Mbps)

2478MHz\_Adapter

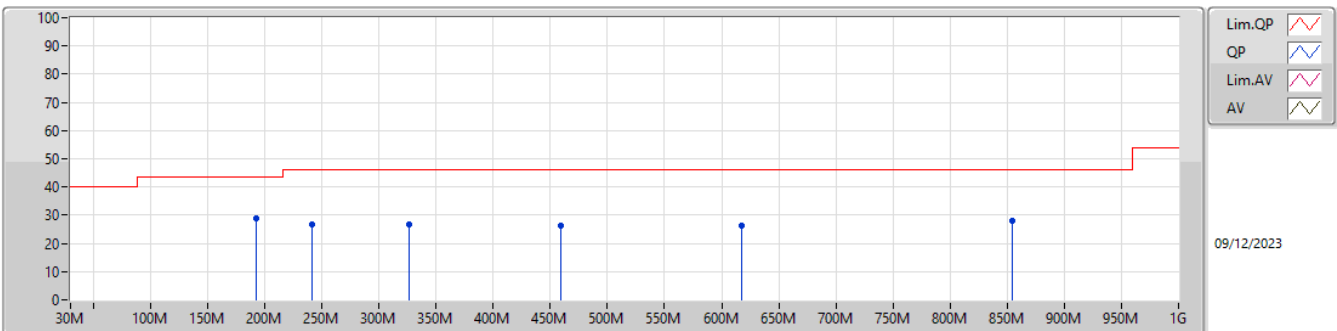

Type	Freq (Hz)	Level (dBuV/m)	Limit (dBuV/m)	Margin (dB)	Factor (dB)	Dist (m)	Condition	Azimuth (°)	Height (m)	Raw (dBuV)	AF (dB)	CL (dB)	PA (dB)
PK	192.96M	28.76	43.50	-14.74	-11.71	3	Horizontal	0	1.00	40.47	14.17	1.03	26.91
PK	241.46M	26.56	46.00	-19.44	-9.03	3	Horizontal	0	1.00	35.59	16.57	1.14	26.74
PK	326.82M	26.63	46.00	-19.37	-6.77	3	Horizontal	0	1.00	33.40	18.82	1.33	26.92
PK	458.74M	26.28	46.00	-19.72	-4.34	3	Horizontal	0	1.00	30.62	22.11	1.58	28.03
PK	617.82M	26.22	46.00	-19.78	-2.76	3	Horizontal	0	1.00	28.98	23.80	1.82	28.38
PK	854.5M	27.93	46.00	-18.07	-0.53	3	Horizontal	0	1.00	28.46	25.32	2.15	28.00

2.4-2.4835GHz\_BT-LE(2Mbps)

2478MHz\_USB

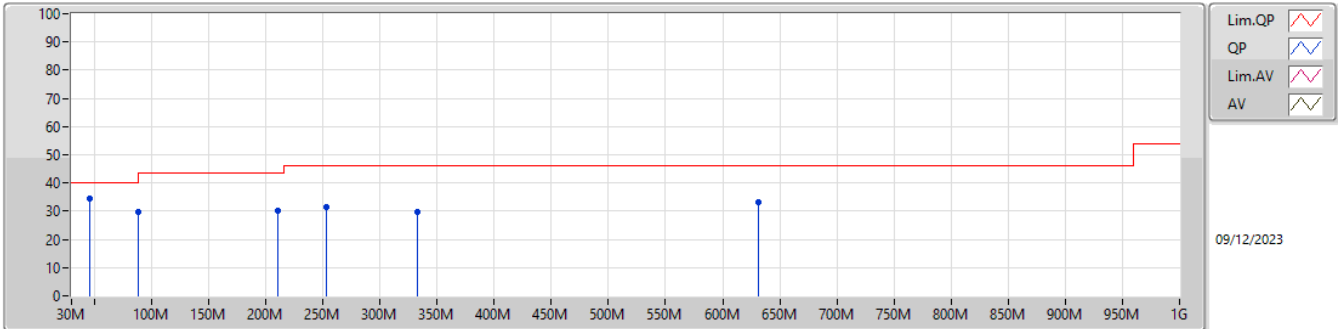

Type	Freq (Hz)	Level (dBuV/m)	Limit (dBuV/m)	Margin (dB)	Factor (dB)	Dist (m)	Condition	Azimuth (°)	Height (m)	Raw (dBuV)	AF (dB)	CL (dB)	PA (dB)
PK	45.52M	34.34	40.00	-5.66	-11.49	3	Vertical	360	1.00	45.83	15.39	0.51	27.39
PK	88.2M	29.58	43.50	-13.92	-12.82	3	Vertical	360	1.00	42.40	13.81	0.70	27.33
PK	210.42M	30.24	43.50	-13.26	-11.55	3	Vertical	360	1.00	41.79	14.21	1.07	26.83
PK	253.1M	31.38	46.00	-14.62	-7.69	3	Vertical	360	1.00	39.07	17.85	1.17	26.71
PK	332.64M	29.72	46.00	-16.28	-6.74	3	Vertical	360	1.00	36.46	18.86	1.35	26.95
PK	631.4M	33.30	46.00	-12.70	-2.45	3	Vertical	360	1.00	35.75	24.11	1.84	28.40

2.4-2.4835GHz\_BT-LE(2Mbps)

2478MHz\_USB

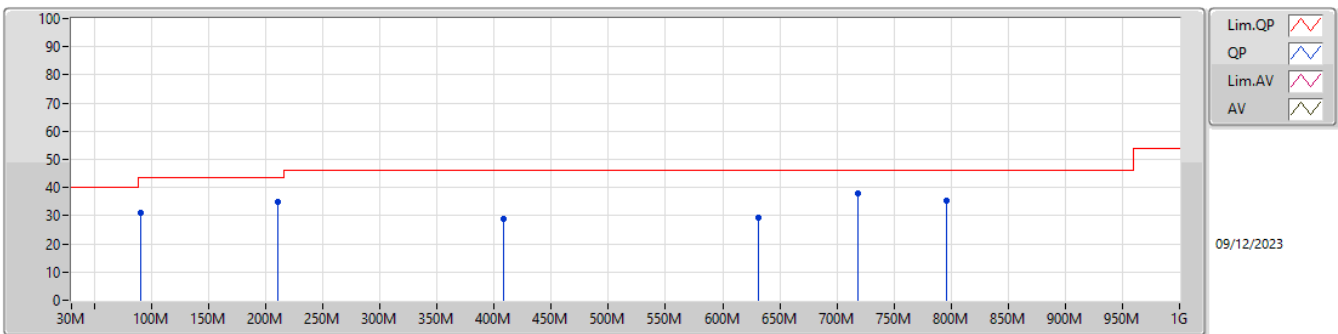

Type	Freq (Hz)	Level (dBuV/m)	Limit (dBuV/m)	Margin (dB)	Factor (dB)	Dist (m)	Condition	Azimuth (°)	Height (m)	Raw (dBuV)	AF (dB)	CL (dB)	PA (dB)
PK	90.14M	31.02	43.50	-12.48	-12.48	3	Horizontal	0	1.00	43.50	14.14	0.71	27.33
PK	210.42M	34.88	43.50	-8.62	-11.55	3	Horizontal	0	1.00	46.43	14.21	1.07	26.83
PK	408.3M	29.02	46.00	-16.98	-4.80	3	Horizontal	0	1.00	33.82	21.30	1.49	27.59
PK	631.4M	29.19	46.00	-16.81	-2.45	3	Horizontal	0	1.00	31.64	24.11	1.84	28.40
PK	718.7M	37.74	46.00	-8.26	-2.31	3	Horizontal	0	1.00	40.05	24.09	1.96	28.36
PK	796.3M	35.22	46.00	-10.78	-1.20	3	Horizontal	0	1.00	36.42	25.04	2.07	28.31



Summary

Mode	Result	Type	Freq (Hz)	Level (dBuV/m)	Limit (dBuV/m)	Margin (dB)	Dist (m)	Condition	Azimuth (°)	Height (m)
2.4-2.4835GHz	-	-	-	-	-	-	-	-	-	-
BT-LE(1Mbps)	Pass	AV	2.5G	45.60	54.00	-8.40	3	Horizontal	170	1.50
BT-LE(2Mbps)	Pass	AV	2.498G	46.88	54.00	-7.12	3	Vertical	294	3.00



Result

Mode	Result	Type	Freq (Hz)	Level (dBuV/m)	Limit (dBuV/m)	Margin (dB)	Dist (m)	Condition	Azimuth (°)	Height (m)
BT-LE(1Mbps)	-	-	-	-	-	-	-	-	-	-
2402MHz	Pass	AV	2.371G	44.98	54.00	-9.02	3	Vertical	308	1.67
2402MHz	Pass	AV	2.402G	93.35	Inf	-Inf	3	Vertical	308	1.67
2402MHz	Pass	PK	2.3884G	56.88	74.00	-17.12	3	Vertical	308	1.67
2402MHz	Pass	PK	2.4018G	94.49	Inf	-Inf	3	Vertical	308	1.67
2402MHz	Pass	AV	2.3856G	45.01	54.00	-8.99	3	Horizontal	188	2.15
2402MHz	Pass	AV	2.402G	97.16	Inf	-Inf	3	Horizontal	188	2.15
2402MHz	Pass	PK	2.3832G	57.42	74.00	-16.58	3	Horizontal	188	2.15
2402MHz	Pass	PK	2.4018G	98.32	Inf	-Inf	3	Horizontal	188	2.15
2402MHz	Pass	AV	4.80602G	29.25	54.00	-24.75	3	Vertical	80	1.68
2402MHz	Pass	PK	4.80472G	41.23	74.00	-32.77	3	Vertical	80	1.68
2402MHz	Pass	AV	4.80632G	29.11	54.00	-24.89	3	Horizontal	242	2.44
2402MHz	Pass	PK	4.80044G	41.37	74.00	-32.63	3	Horizontal	242	2.44
2440MHz	Pass	AV	2.3728G	45.18	54.00	-8.82	3	Vertical	309	2.56
2440MHz	Pass	AV	2.44G	92.57	Inf	-Inf	3	Vertical	309	2.56
2440MHz	Pass	AV	2.4996G	45.47	54.00	-8.53	3	Vertical	309	2.56
2440MHz	Pass	PK	2.3596G	57.31	74.00	-16.69	3	Vertical	309	2.56
2440MHz	Pass	PK	2.4396G	93.67	Inf	-Inf	3	Vertical	309	2.56
2440MHz	Pass	PK	2.4852G	57.07	74.00	-16.93	3	Vertical	309	2.56
2440MHz	Pass	AV	2.388G	44.84	54.00	-9.16	3	Horizontal	176	1.56
2440MHz	Pass	AV	2.44G	96.78	Inf	-Inf	3	Horizontal	176	1.56
2440MHz	Pass	AV	2.49G	45.52	54.00	-8.48	3	Horizontal	176	1.56
2440MHz	Pass	PK	2.3792G	57.43	74.00	-16.57	3	Horizontal	176	1.56
2440MHz	Pass	PK	2.4404G	97.86	Inf	-Inf	3	Horizontal	176	1.56
2440MHz	Pass	PK	2.496G	57.68	74.00	-16.32	3	Horizontal	176	1.56
2440MHz	Pass	AV	4.8823G	29.79	54.00	-24.21	3	Vertical	258	1.67
2440MHz	Pass	PK	4.8848G	42.23	74.00	-31.77	3	Vertical	258	1.67
2440MHz	Pass	AV	4.88256G	29.95	54.00	-24.05	3	Horizontal	91	2.07
2440MHz	Pass	PK	4.88404G	42.14	74.00	-31.86	3	Horizontal	91	2.07
2480MHz	Pass	AV	2.48G	96.14	Inf	-Inf	3	Vertical	313	2.02
2480MHz	Pass	AV	2.4878G	45.56	54.00	-8.44	3	Vertical	313	2.02
2480MHz	Pass	PK	2.4798G	97.21	Inf	-Inf	3	Vertical	313	2.02
2480MHz	Pass	PK	2.4926G	57.31	74.00	-16.69	3	Vertical	313	2.02
2480MHz	Pass	AV	2.48G	99.78	Inf	-Inf	3	Horizontal	170	1.50
2480MHz	Pass	AV	2.5G	45.60	54.00	-8.40	3	Horizontal	170	1.50
2480MHz	Pass	PK	2.4798G	100.86	Inf	-Inf	3	Horizontal	170	1.50
2480MHz	Pass	PK	2.4888G	58.19	74.00	-15.81	3	Horizontal	170	1.50
2480MHz	Pass	AV	4.95684G	30.57	54.00	-23.43	3	Vertical	67	2.07
2480MHz	Pass	PK	4.95906G	42.93	74.00	-31.07	3	Vertical	67	2.07
2480MHz	Pass	AV	4.96426G	30.49	54.00	-23.51	3	Horizontal	340	2.85
2480MHz	Pass	PK	4.96428G	43.02	74.00	-30.98	3	Horizontal	340	2.85
BT-LE(2Mbps)	-	-	-	-	-	-	-	-	-	-
2404MHz	Pass	AV	2.3792G	46.57	54.00	-7.43	3	Vertical	300	2.85
2404MHz	Pass	AV	2.404G	91.67	Inf	-Inf	3	Vertical	300	2.85
2404MHz	Pass	PK	2.381G	57.36	74.00	-16.64	3	Vertical	300	2.85
2404MHz	Pass	PK	2.4036G	94.20	Inf	-Inf	3	Vertical	300	2.85
2404MHz	Pass	AV	2.387G	46.63	54.00	-7.37	3	Horizontal	187	2.19
2404MHz	Pass	AV	2.404G	95.13	Inf	-Inf	3	Horizontal	187	2.19
2404MHz	Pass	PK	2.378G	57.44	74.00	-16.56	3	Horizontal	187	2.19
2404MHz	Pass	PK	2.4036G	97.58	Inf	-Inf	3	Horizontal	187	2.19
2404MHz	Pass	AV	4.80862G	30.52	54.00	-23.48	3	Vertical	254	2.98
2404MHz	Pass	PK	4.80752G	41.58	74.00	-32.42	3	Vertical	254	2.98
2404MHz	Pass	AV	4.80694G	30.69	54.00	-23.31	3	Horizontal	173	2.20
2404MHz	Pass	PK	4.80948G	41.23	74.00	-32.77	3	Horizontal	173	2.20
2440MHz	Pass	AV	2.374G	46.51	54.00	-7.49	3	Vertical	294	3.00
2440MHz	Pass	AV	2.44G	91.55	Inf	-Inf	3	Vertical	294	3.00
2440MHz	Pass	AV	2.498G	46.88	54.00	-7.12	3	Vertical	294	3.00
2440MHz	Pass	PK	2.3772G	57.20	74.00	-16.80	3	Vertical	294	3.00
2440MHz	Pass	PK	2.4404G	93.91	Inf	-Inf	3	Vertical	294	3.00
2440MHz	Pass	PK	2.4848G	57.37	74.00	-16.63	3	Vertical	294	3.00
2440MHz	Pass	AV	2.3708G	46.80	54.00	-7.20	3	Horizontal	176	1.56



**RSE TX above 1GHz\_Left**

**Appendix F.4**

Mode	Result	Type	Freq (Hz)	Level (dBuV/m)	Limit (dBuV/m)	Margin (dB)	Dist (m)	Condition	Azimuth (°)	Height (m)
2440MHz	Pass	AV	2.44G	95.51	Inf	-Inf	3	Horizontal	176	1.56
2440MHz	Pass	AV	2.4912G	46.79	54.00	-7.21	3	Horizontal	176	1.56
2440MHz	Pass	PK	2.3592G	57.12	74.00	-16.88	3	Horizontal	176	1.56
2440MHz	Pass	PK	2.4404G	97.83	Inf	-Inf	3	Horizontal	176	1.56
2440MHz	Pass	PK	2.4852G	57.13	74.00	-16.87	3	Horizontal	176	1.56
2440MHz	Pass	AV	4.88148G	31.16	54.00	-22.84	3	Vertical	260	2.90
2440MHz	Pass	PK	4.8788G	41.99	74.00	-32.01	3	Vertical	260	2.90
2440MHz	Pass	AV	4.88454G	31.68	54.00	-22.32	3	Horizontal	97	2.55
2440MHz	Pass	PK	4.8798G	41.69	74.00	-32.31	3	Horizontal	97	2.55
2478MHz	Pass	AV	2.478G	94.38	Inf	-Inf	3	Vertical	312	2.01
2478MHz	Pass	AV	2.4856G	46.84	54.00	-7.16	3	Vertical	312	2.01
2478MHz	Pass	PK	2.4784G	96.91	Inf	-Inf	3	Vertical	312	2.01
2478MHz	Pass	PK	2.4926G	57.33	74.00	-16.67	3	Vertical	312	2.01
2478MHz	Pass	AV	2.478G	98.19	Inf	-Inf	3	Horizontal	169	1.52
2478MHz	Pass	AV	2.4882G	46.80	54.00	-7.20	3	Horizontal	169	1.52
2478MHz	Pass	PK	2.4786G	100.69	Inf	-Inf	3	Horizontal	169	1.52
2478MHz	Pass	PK	2.4978G	57.77	74.00	-16.23	3	Horizontal	169	1.52
2478MHz	Pass	AV	4.95534G	32.05	54.00	-21.95	3	Vertical	106	1.49
2478MHz	Pass	PK	4.95278G	42.82	74.00	-31.18	3	Vertical	106	1.49
2478MHz	Pass	AV	4.95678G	31.95	54.00	-22.05	3	Horizontal	94	1.46
2478MHz	Pass	PK	4.95392G	42.74	74.00	-31.26	3	Horizontal	94	1.46

2.4-2.4835GHz\_BT-LE(1Mbps)

2402MHz\_TX

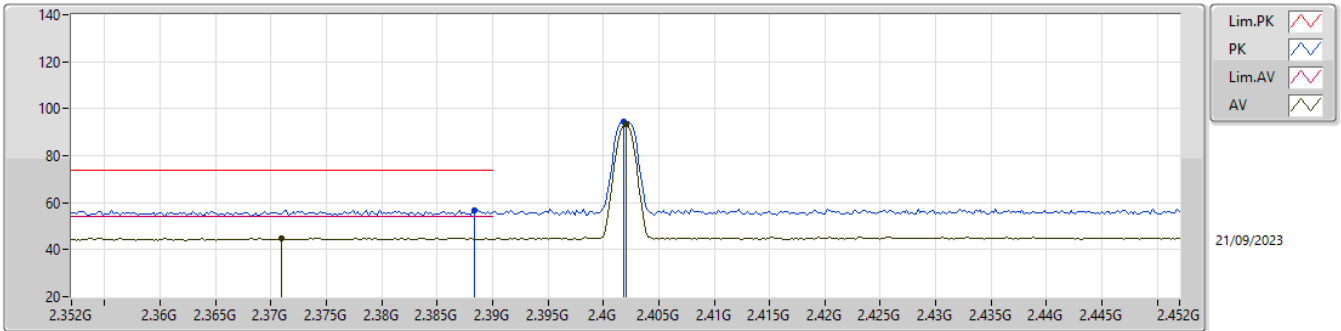

Type	Freq (Hz)	Level (dBuV/m)	Limit (dBuV/m)	Margin (dB)	Factor (dB)	Dist (m)	Condition	Azimuth (°)	Height (m)	Raw (dBuV)	AF (dB)	CL (dB)	PA (dB)
AV	2.371G	44.98	54.00	-9.02	31.12	3	Vertical	308	1.67	13.86	27.50	3.62	-
AV	2.402G	93.35	Inf	-Inf	31.34	3	Vertical	308	1.67	62.01	27.70	3.64	-
PK	2.3884G	56.88	74.00	-17.12	31.21	3	Vertical	308	1.67	25.67	27.58	3.63	-
PK	2.4018G	94.49	Inf	-Inf	31.34	3	Vertical	308	1.67	63.15	27.70	3.64	-

2.4-2.4835GHz\_BT-LE(1Mbps)

2402MHz\_TX

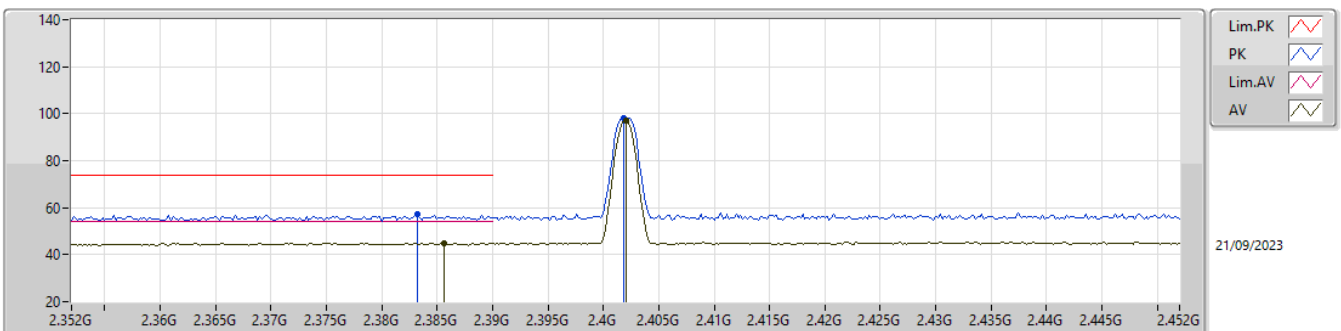

Type	Freq (Hz)	Level (dBuV/m)	Limit (dBuV/m)	Margin (dB)	Factor (dB)	Dist (m)	Condition	Azimuth (°)	Height (m)	Raw (dBuV)	AF (dB)	CL (dB)	PA (dB)
AV	2.3856G	45.01	54.00	-8.99	31.19	3	Horizontal	188	2.15	13.82	27.56	3.63	-
AV	2.402G	97.16	Inf	-Inf	31.34	3	Horizontal	188	2.15	65.82	27.70	3.64	-
PK	2.3832G	57.42	74.00	-16.58	31.16	3	Horizontal	188	2.15	26.26	27.53	3.63	-
PK	2.4018G	98.32	Inf	-Inf	31.34	3	Horizontal	188	2.15	66.98	27.70	3.64	-

2.4-2.4835GHz\_BT-LE(1Mbps)

2402MHz\_TX

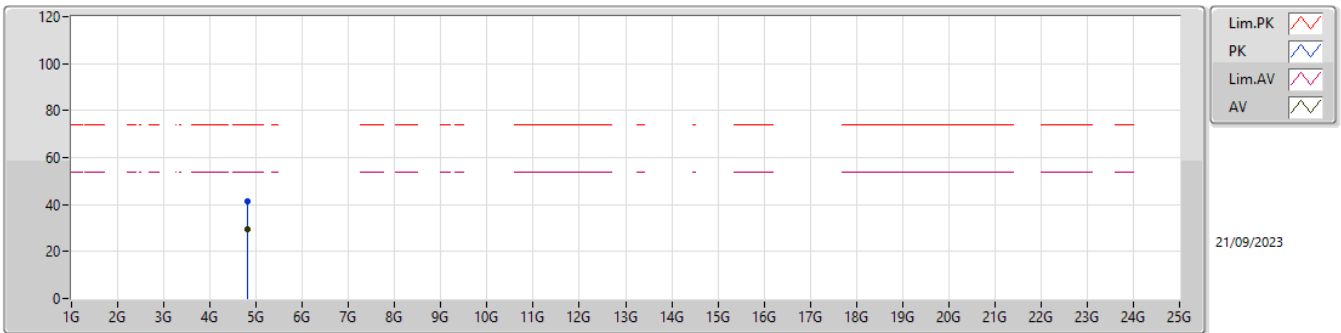

Type	Freq (Hz)	Level (dBuV/m)	Limit (dBuV/m)	Margin (dB)	Factor (dB)	Dist (m)	Condition	Azimuth (°)	Height (m)	Raw (dBuV)	AF (dB)	CL (dB)	PA (dB)
AV	4.80602G	29.25	54.00	-24.75	0.41	3	Vertical	80	1.68	28.84	32.54	5.29	37.42
PK	4.80472G	41.23	74.00	-32.77	0.40	3	Vertical	80	1.68	40.83	32.53	5.29	37.42

2.4-2.4835GHz\_BT-LE(1Mbps)

2402MHz\_TX

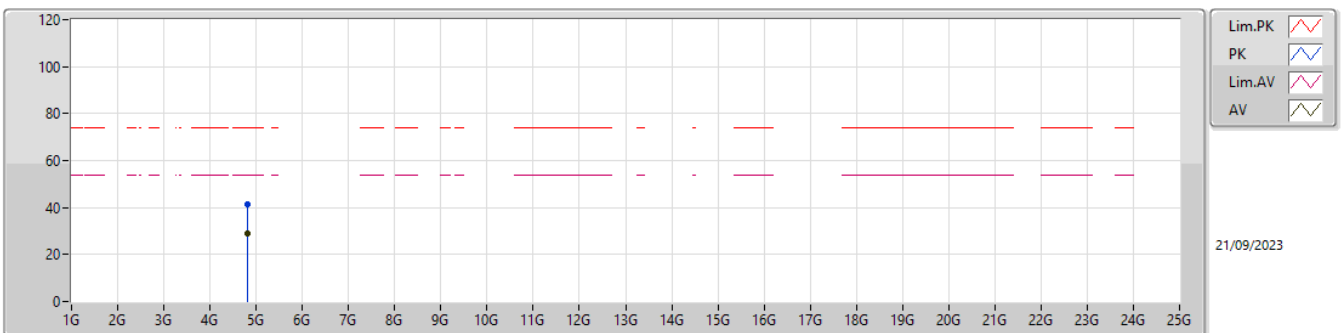

Type	Freq (Hz)	Level (dBuV/m)	Limit (dBuV/m)	Margin (dB)	Factor (dB)	Dist (m)	Condition	Azimuth (°)	Height (m)	Raw (dBuV)	AF (dB)	CL (dB)	PA (dB)
AV	4.80632G	29.11	54.00	-24.89	0.41	3	Horizontal	242	2.44	28.70	32.54	5.29	37.42
PK	4.80044G	41.37	74.00	-32.63	0.37	3	Horizontal	242	2.44	41.00	32.50	5.29	37.42

2.4-2.4835GHz\_BT-LE(1Mbps)

2440MHz\_TX

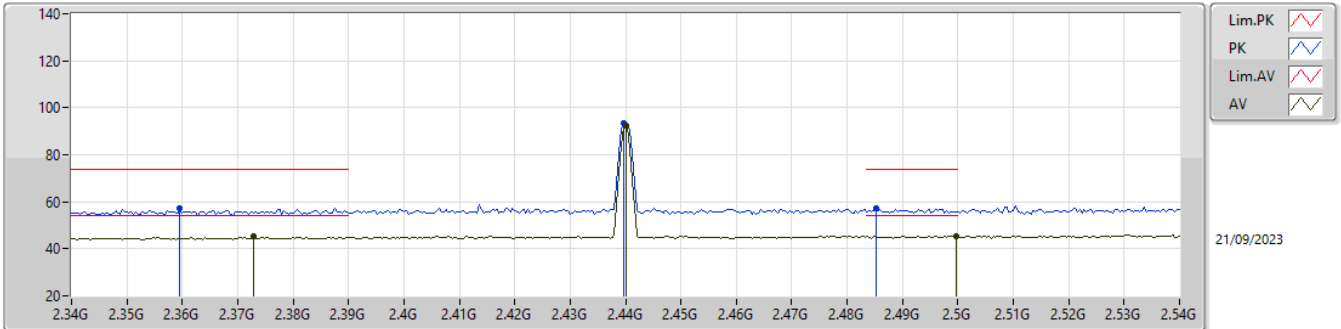

Type	Freq (Hz)	Level (dBuV/m)	Limit (dBuV/m)	Margin (dB)	Factor (dB)	Dist (m)	Condition	Azimuth (°)	Height (m)	Raw (dBuV)	AF (dB)	CL (dB)	PA (dB)
AV	2.3728G	45.18	54.00	-8.82	31.12	3	Vertical	309	2.56	14.06	27.50	3.62	-
AV	2.44G	92.57	Inf	-Inf	31.37	3	Vertical	309	2.56	61.20	27.70	3.67	-
AV	2.4996G	45.47	54.00	-8.53	31.52	3	Vertical	309	2.56	13.95	27.80	3.72	-
PK	2.3596G	57.31	74.00	-16.69	31.01	3	Vertical	309	2.56	26.30	27.40	3.61	-
PK	2.4396G	93.67	Inf	-Inf	31.37	3	Vertical	309	2.56	62.30	27.70	3.67	-
PK	2.4852G	57.07	74.00	-16.93	31.51	3	Vertical	309	2.56	25.56	27.80	3.71	-

2.4-2.4835GHz\_BT-LE(1Mbps)

2440MHz\_TX

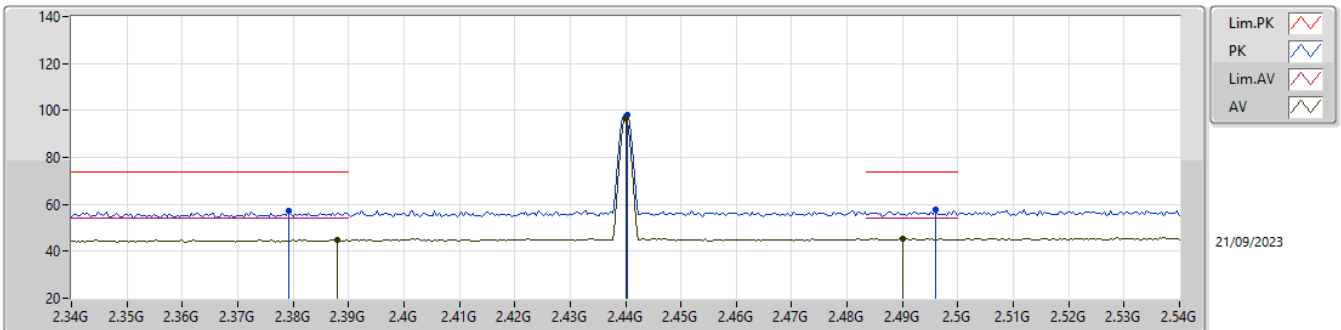

Type	Freq (Hz)	Level (dBuV/m)	Limit (dBuV/m)	Margin (dB)	Factor (dB)	Dist (m)	Condition	Azimuth (°)	Height (m)	Raw (dBuV)	AF (dB)	CL (dB)	PA (dB)
AV	2.388G	44.84	54.00	-9.16	31.21	3	Horizontal	176	1.56	13.63	27.58	3.63	-
AV	2.44G	96.78	Inf	-Inf	31.37	3	Horizontal	176	1.56	65.41	27.70	3.67	-
AV	2.49G	45.52	54.00	-8.48	31.51	3	Horizontal	176	1.56	14.01	27.80	3.71	-
PK	2.3792G	57.43	74.00	-16.57	31.13	3	Horizontal	176	1.56	26.30	27.50	3.63	-
PK	2.4404G	97.86	Inf	-Inf	31.37	3	Horizontal	176	1.56	66.49	27.70	3.67	-
PK	2.496G	57.68	74.00	-16.32	31.52	3	Horizontal	176	1.56	26.16	27.80	3.72	-



2.4-2.4835GHz\_BT-LE(1Mbps)

2440MHz\_TX

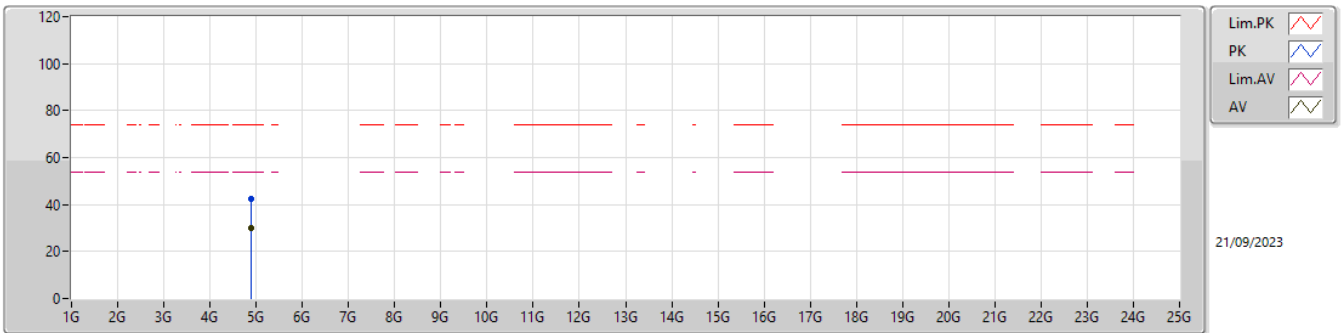

Type	Freq (Hz)	Level (dBuV/m)	Limit (dBuV/m)	Margin (dB)	Factor (dB)	Dist (m)	Condition	Azimuth (°)	Height (m)	Raw (dBuV)	AF (dB)	CL (dB)	PA (dB)
AV	4.8823G	29.79	54.00	-24.21	0.80	3	Vertical	258	1.67	28.99	32.80	5.33	37.33
PK	4.8848G	42.23	74.00	-31.77	0.80	3	Vertical	258	1.67	41.43	32.80	5.33	37.33

2.4-2.4835GHz\_BT-LE(1Mbps)

2440MHz\_TX

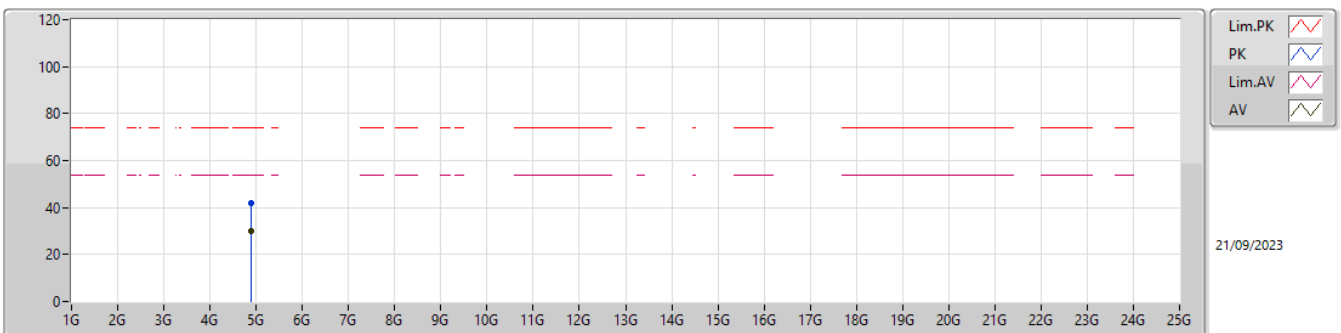

Type	Freq (Hz)	Level (dBuV/m)	Limit (dBuV/m)	Margin (dB)	Factor (dB)	Dist (m)	Condition	Azimuth (°)	Height (m)	Raw (dBuV)	AF (dB)	CL (dB)	PA (dB)
AV	4.88256G	29.95	54.00	-24.05	0.80	3	Horizontal	91	2.07	29.15	32.80	5.33	37.33
PK	4.88404G	42.14	74.00	-31.86	0.80	3	Horizontal	91	2.07	41.34	32.80	5.33	37.33

2.4-2.4835GHz\_BT-LE(1Mbps)

2480MHz\_TX

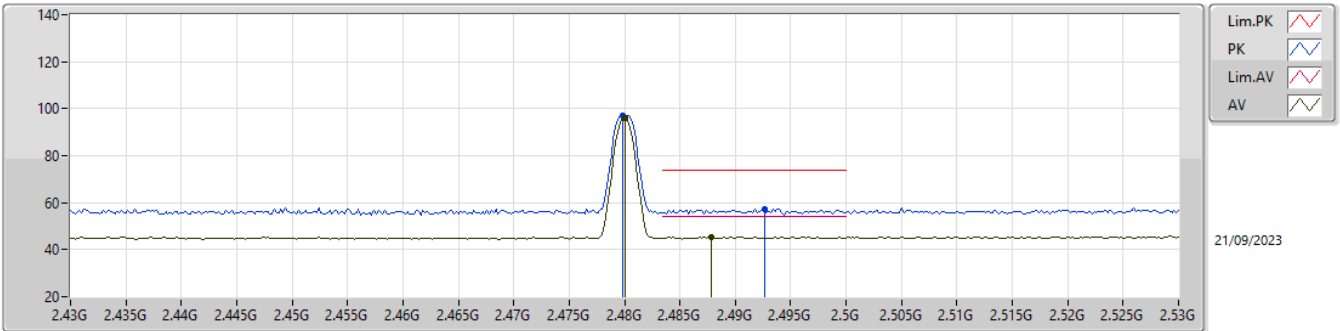

Type	Freq (Hz)	Level (dBuV/m)	Limit (dBuV/m)	Margin (dB)	Factor (dB)	Dist (m)	Condition	Azimuth (°)	Height (m)	Raw (dBuV)	AF (dB)	CL (dB)	PA (dB)
AV	2.48G	96.14	Inf	-Inf	31.50	3	Vertical	313	2.02	64.64	27.80	3.70	-
AV	2.4878G	45.56	54.00	-8.44	31.51	3	Vertical	313	2.02	14.05	27.80	3.71	-
PK	2.4798G	97.21	Inf	-Inf	31.50	3	Vertical	313	2.02	65.71	27.80	3.70	-
PK	2.4926G	57.31	74.00	-16.69	31.51	3	Vertical	313	2.02	25.80	27.80	3.71	-

2.4-2.4835GHz\_BT-LE(1Mbps)

2480MHz\_TX

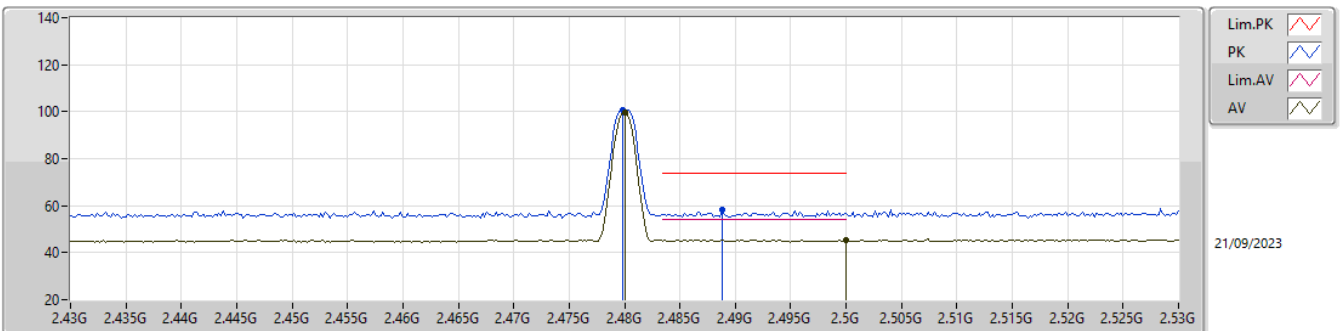

Type	Freq (Hz)	Level (dBuV/m)	Limit (dBuV/m)	Margin (dB)	Factor (dB)	Dist (m)	Condition	Azimuth (°)	Height (m)	Raw (dBuV)	AF (dB)	CL (dB)	PA (dB)
AV	2.48G	99.78	Inf	-Inf	31.50	3	Horizontal	170	1.50	68.28	27.80	3.70	-
AV	2.5G	45.60	54.00	-8.40	31.52	3	Horizontal	170	1.50	14.08	27.80	3.72	-
PK	2.4798G	100.86	Inf	-Inf	31.50	3	Horizontal	170	1.50	69.36	27.80	3.70	-
PK	2.4888G	58.19	74.00	-15.81	31.51	3	Horizontal	170	1.50	26.68	27.80	3.71	-

2.4-2.4835GHz\_BT-LE(1Mbps)

2480MHz\_TX

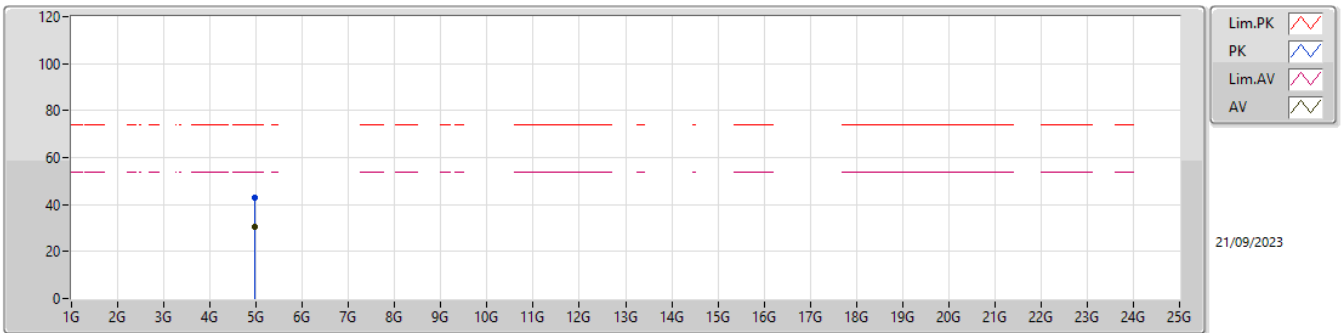

Type	Freq (Hz)	Level (dBuV/m)	Limit (dBuV/m)	Margin (dB)	Factor (dB)	Dist (m)	Condition	Azimuth (°)	Height (m)	Raw (dBuV)	AF (dB)	CL (dB)	PA (dB)
AV	4.95684G	30.57	54.00	-23.43	1.25	3	Vertical	67	2.07	29.32	33.14	5.36	37.25
PK	4.95906G	42.93	74.00	-31.07	1.26	3	Vertical	67	2.07	41.67	33.15	5.36	37.25

2.4-2.4835GHz\_BT-LE(1Mbps)

2480MHz\_TX

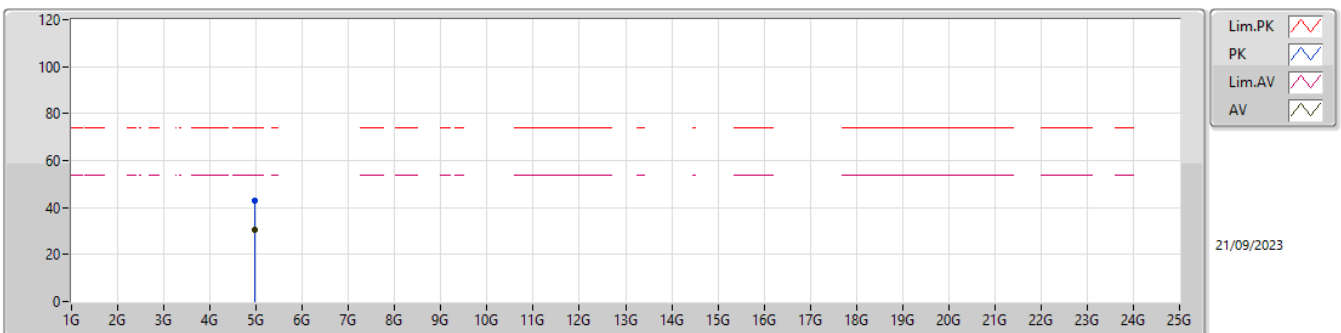

Type	Freq (Hz)	Level (dBuV/m)	Limit (dBuV/m)	Margin (dB)	Factor (dB)	Dist (m)	Condition	Azimuth (°)	Height (m)	Raw (dBuV)	AF (dB)	CL (dB)	PA (dB)
AV	4.96426G	30.49	54.00	-23.51	1.31	3	Horizontal	340	2.85	29.18	33.19	5.36	37.24
PK	4.96428G	43.02	74.00	-30.98	1.31	3	Horizontal	340	2.85	41.71	33.19	5.36	37.24

2.4-2.4835GHz\_BT-LE(2Mbps)

2404MHz\_TX

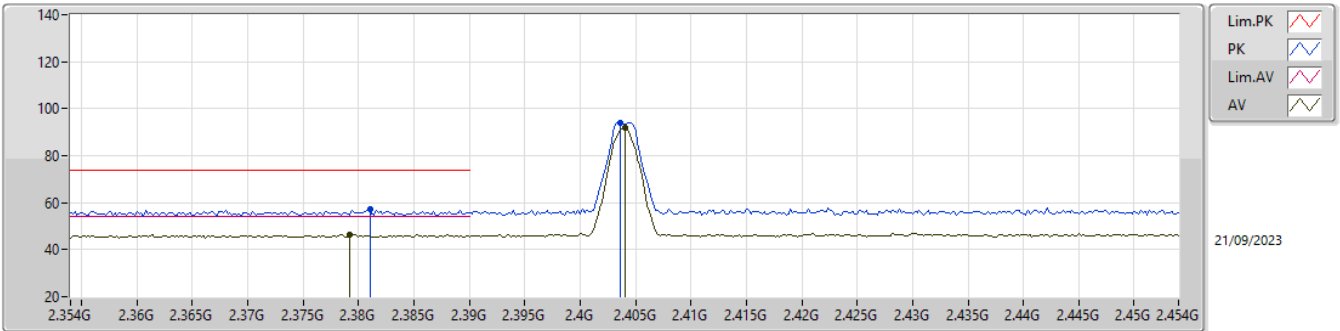

Type	Freq (Hz)	Level (dBuV/m)	Limit (dBuV/m)	Margin (dB)	Factor (dB)	Dist (m)	Condition	Azimuth (°)	Height (m)	Raw (dBuV)	AF (dB)	CL (dB)	PA (dB)
AV	2.3792G	46.57	54.00	-7.43	31.13	3	Vertical	300	2.85	15.44	27.50	3.63	-
AV	2.404G	91.67	Inf	-Inf	31.34	3	Vertical	300	2.85	60.33	27.70	3.64	-
PK	2.381G	57.36	74.00	-16.64	31.14	3	Vertical	300	2.85	26.22	27.51	3.63	-
PK	2.4036G	94.20	Inf	-Inf	31.34	3	Vertical	300	2.85	62.86	27.70	3.64	-

2.4-2.4835GHz\_BT-LE(2Mbps)

2404MHz\_TX

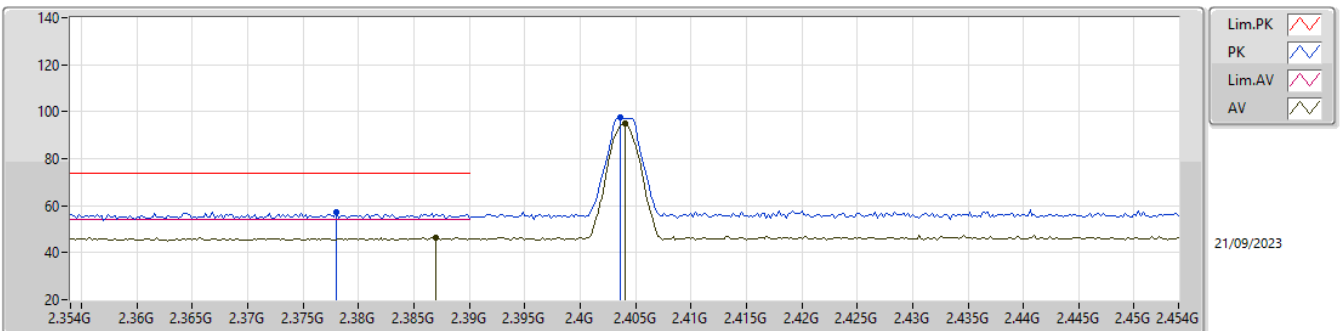

Type	Freq (Hz)	Level (dBuV/m)	Limit (dBuV/m)	Margin (dB)	Factor (dB)	Dist (m)	Condition	Azimuth (°)	Height (m)	Raw (dBuV)	AF (dB)	CL (dB)	PA (dB)
AV	2.387G	46.63	54.00	-7.37	31.20	3	Horizontal	187	2.19	15.43	27.57	3.63	-
AV	2.404G	95.13	Inf	-Inf	31.34	3	Horizontal	187	2.19	63.79	27.70	3.64	-
PK	2.378G	57.44	74.00	-16.56	31.12	3	Horizontal	187	2.19	26.32	27.50	3.62	-
PK	2.4036G	97.58	Inf	-Inf	31.34	3	Horizontal	187	2.19	66.24	27.70	3.64	-

2.4-2.4835GHz\_BT-LE(2Mbps)

2404MHz\_TX

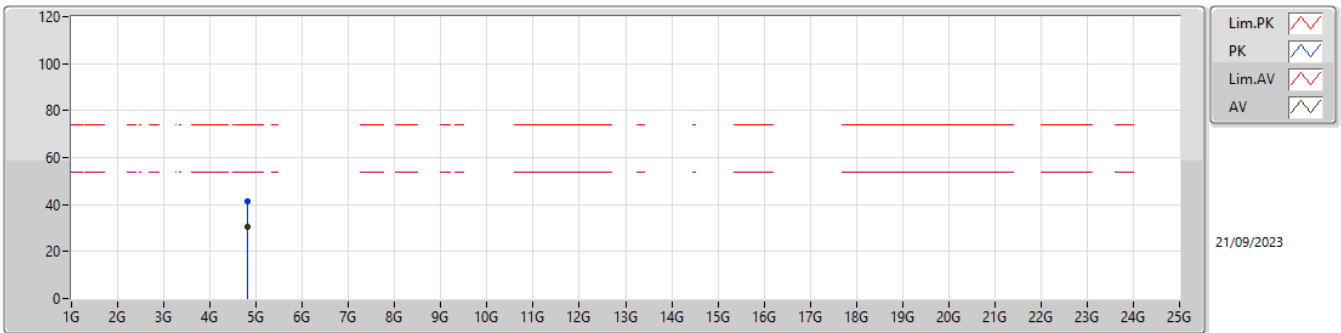

Type	Freq (Hz)	Level (dBuV/m)	Limit (dBuV/m)	Margin (dB)	Factor (dB)	Dist (m)	Condition	Azimuth (°)	Height (m)	Raw (dBuV)	AF (dB)	CL (dB)	PA (dB)
AV	4.80862G	30.52	54.00	-23.48	0.43	3	Vertical	254	2.98	30.09	32.55	5.29	37.41
PK	4.80752G	41.58	74.00	-32.42	0.42	3	Vertical	254	2.98	41.16	32.55	5.29	37.42

2.4-2.4835GHz\_BT-LE(2Mbps)

2404MHz\_TX

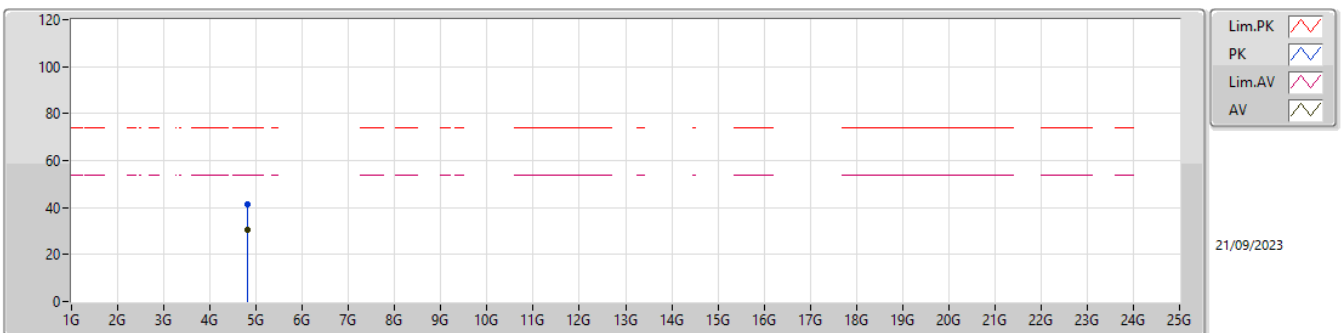

Type	Freq (Hz)	Level (dBuV/m)	Limit (dBuV/m)	Margin (dB)	Factor (dB)	Dist (m)	Condition	Azimuth (°)	Height (m)	Raw (dBuV)	AF (dB)	CL (dB)	PA (dB)
AV	4.80694G	30.69	54.00	-23.31	0.41	3	Horizontal	173	2.20	30.28	32.54	5.29	37.42
PK	4.80948G	41.23	74.00	-32.77	0.44	3	Horizontal	173	2.20	40.79	32.56	5.29	37.41

2.4-2.4835GHz\_BT-LE(2Mbps)

2440MHz\_TX

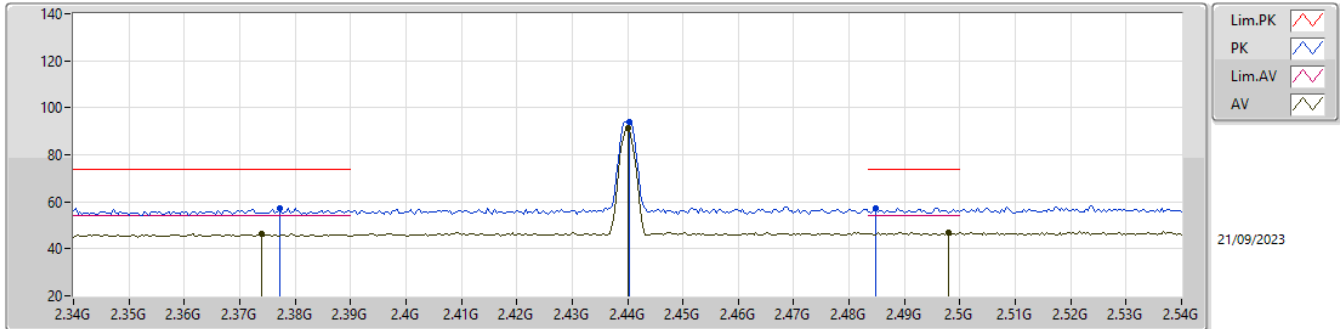

Type	Freq (Hz)	Level (dBuV/m)	Limit (dBuV/m)	Margin (dB)	Factor (dB)	Dist (m)	Condition	Azimuth (°)	Height (m)	Raw (dBuV)	AF (dB)	CL (dB)	PA (dB)
AV	2.374G	46.51	54.00	-7.49	31.12	3	Vertical	294	3.00	15.39	27.50	3.62	-
AV	2.44G	91.55	Inf	-Inf	31.37	3	Vertical	294	3.00	60.18	27.70	3.67	-
AV	2.498G	46.88	54.00	-7.12	31.52	3	Vertical	294	3.00	15.36	27.80	3.72	-
PK	2.3772G	57.20	74.00	-16.80	31.12	3	Vertical	294	3.00	26.08	27.50	3.62	-
PK	2.4404G	93.91	Inf	-Inf	31.37	3	Vertical	294	3.00	62.54	27.70	3.67	-
PK	2.4848G	57.37	74.00	-16.63	31.51	3	Vertical	294	3.00	25.86	27.80	3.71	-

2.4-2.4835GHz\_BT-LE(2Mbps)

2440MHz\_TX

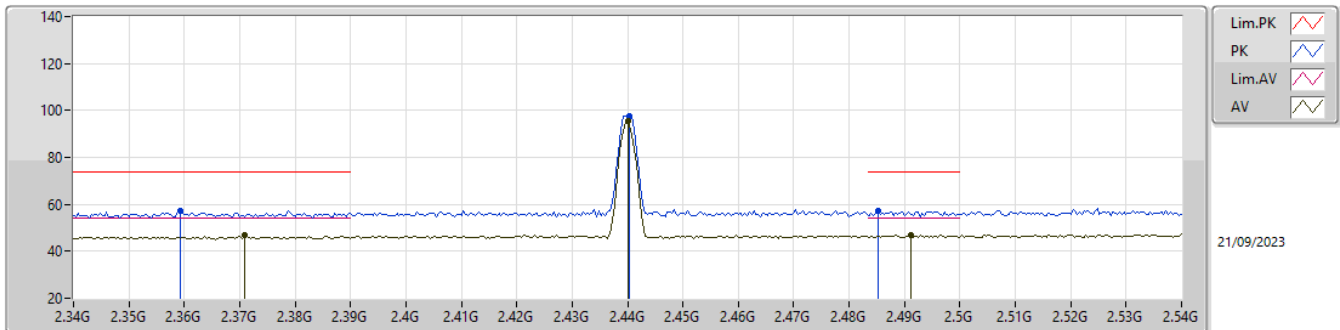

Type	Freq (Hz)	Level (dBuV/m)	Limit (dBuV/m)	Margin (dB)	Factor (dB)	Dist (m)	Condition	Azimuth (°)	Height (m)	Raw (dBuV)	AF (dB)	CL (dB)	PA (dB)
AV	2.3708G	46.80	54.00	-7.20	31.12	3	Horizontal	176	1.56	15.68	27.50	3.62	-
AV	2.44G	95.51	Inf	-Inf	31.37	3	Horizontal	176	1.56	64.14	27.70	3.67	-
AV	2.4912G	46.79	54.00	-7.21	31.51	3	Horizontal	176	1.56	15.28	27.80	3.71	-
PK	2.3592G	57.12	74.00	-16.88	31.01	3	Horizontal	176	1.56	26.11	27.40	3.61	-
PK	2.4404G	97.83	Inf	-Inf	31.37	3	Horizontal	176	1.56	66.46	27.70	3.67	-
PK	2.4852G	57.13	74.00	-16.87	31.51	3	Horizontal	176	1.56	25.62	27.80	3.71	-

2.4-2.4835GHz\_BT-LE(2Mbps)

2440MHz\_TX

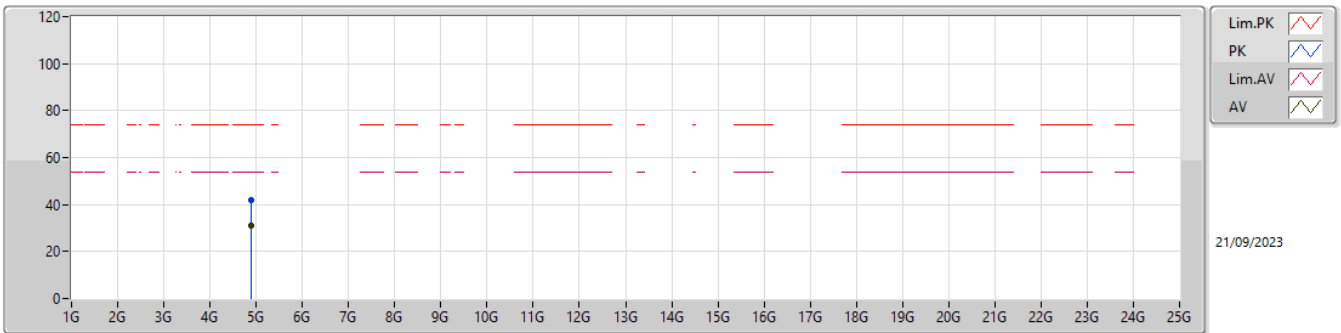

Type	Freq (Hz)	Level (dBuV/m)	Limit (dBuV/m)	Margin (dB)	Factor (dB)	Dist (m)	Condition	Azimuth (°)	Height (m)	Raw (dBuV)	AF (dB)	CL (dB)	PA (dB)
AV	4.88148G	31.16	54.00	-22.84	0.80	3	Vertical	260	2.90	30.36	32.80	5.33	37.33
PK	4.8788G	41.99	74.00	-32.01	0.79	3	Vertical	260	2.90	41.20	32.80	5.33	37.34

2.4-2.4835GHz\_BT-LE(2Mbps)

2440MHz\_TX

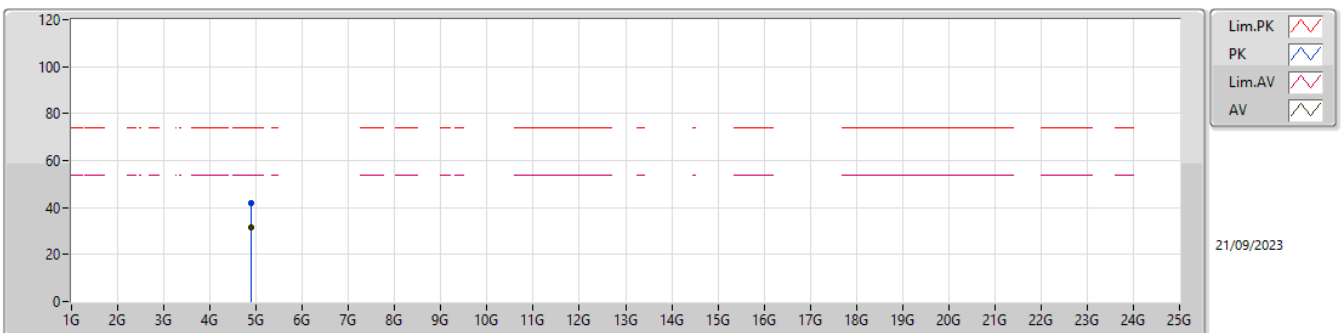

Type	Freq (Hz)	Level (dBuV/m)	Limit (dBuV/m)	Margin (dB)	Factor (dB)	Dist (m)	Condition	Azimuth (°)	Height (m)	Raw (dBuV)	AF (dB)	CL (dB)	PA (dB)
AV	4.88454G	31.68	54.00	-22.32	0.80	3	Horizontal	97	2.55	30.88	32.80	5.33	37.33
PK	4.8798G	41.69	74.00	-32.31	0.80	3	Horizontal	97	2.55	40.89	32.80	5.33	37.33

2.4-2.4835GHz\_BT-LE(2Mbps)

2478MHz\_TX

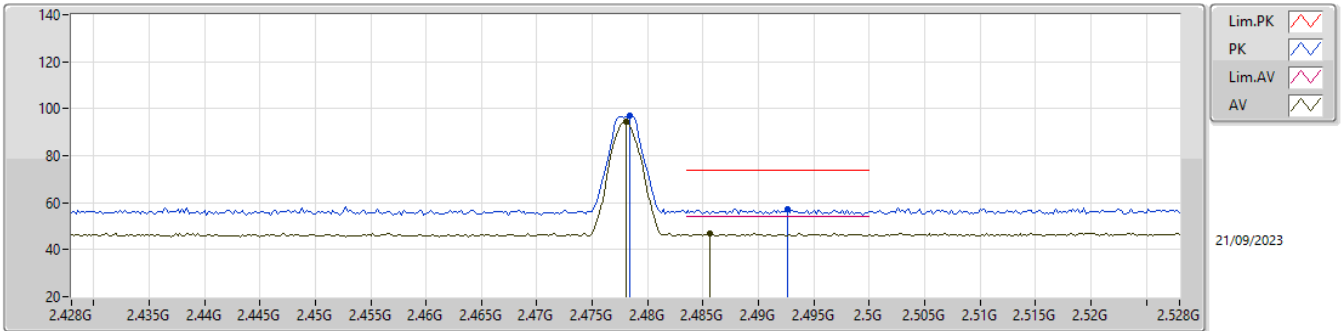

Type	Freq (Hz)	Level (dBuV/m)	Limit (dBuV/m)	Margin (dB)	Factor (dB)	Dist (m)	Condition	Azimuth (°)	Height (m)	Raw (dBuV)	AF (dB)	CL (dB)	PA (dB)
AV	2.478G	94.38	Inf	-Inf	31.48	3	Vertical	312	2.01	62.90	27.78	3.70	-
AV	2.4856G	46.84	54.00	-7.16	31.51	3	Vertical	312	2.01	15.33	27.80	3.71	-
PK	2.4784G	96.91	Inf	-Inf	31.48	3	Vertical	312	2.01	65.43	27.78	3.70	-
PK	2.4926G	57.33	74.00	-16.67	31.51	3	Vertical	312	2.01	25.82	27.80	3.71	-

2.4-2.4835GHz\_BT-LE(2Mbps)

2478MHz\_TX

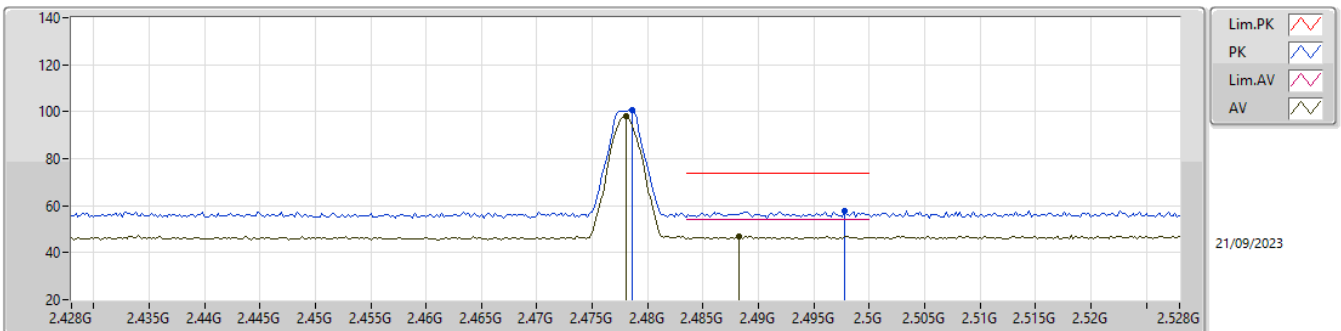

Type	Freq (Hz)	Level (dBuV/m)	Limit (dBuV/m)	Margin (dB)	Factor (dB)	Dist (m)	Condition	Azimuth (°)	Height (m)	Raw (dBuV)	AF (dB)	CL (dB)	PA (dB)
AV	2.478G	98.19	Inf	-Inf	31.48	3	Horizontal	169	1.52	66.71	27.78	3.70	-
AV	2.4882G	46.80	54.00	-7.20	31.51	3	Horizontal	169	1.52	15.29	27.80	3.71	-
PK	2.4786G	100.69	Inf	-Inf	31.49	3	Horizontal	169	1.52	69.20	27.79	3.70	-
PK	2.4978G	57.77	74.00	-16.23	31.52	3	Horizontal	169	1.52	26.25	27.80	3.72	-



2.4-2.4835GHz\_BT-LE(2Mbps)

2478MHz\_TX

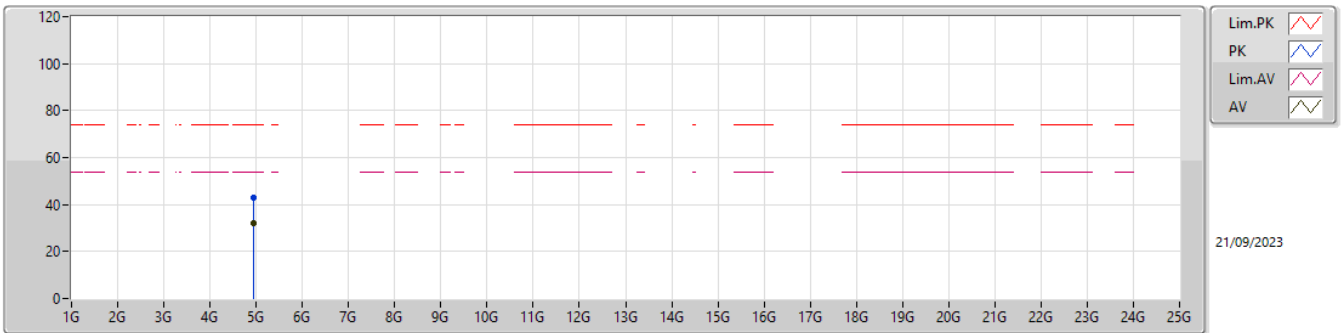

Type	Freq (Hz)	Level (dBuV/m)	Limit (dBuV/m)	Margin (dB)	Factor (dB)	Dist (m)	Condition	Azimuth (°)	Height (m)	Raw (dBuV)	AF (dB)	CL (dB)	PA (dB)
AV	4.95534G	32.05	54.00	-21.95	1.24	3	Vertical	106	1.49	30.81	33.13	5.36	37.25
PK	4.95278G	42.82	74.00	-31.18	1.23	3	Vertical	106	1.49	41.59	33.12	5.36	37.25

2.4-2.4835GHz\_BT-LE(2Mbps)

2478MHz\_TX

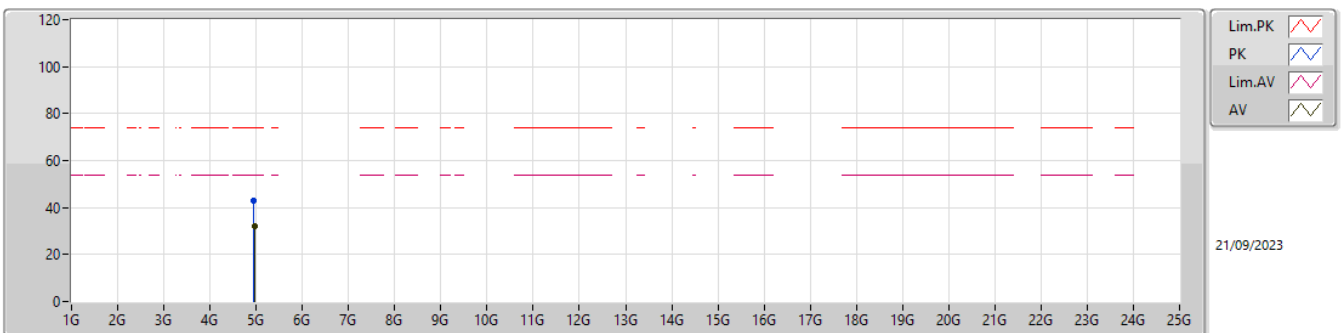

Type	Freq (Hz)	Level (dBuV/m)	Limit (dBuV/m)	Margin (dB)	Factor (dB)	Dist (m)	Condition	Azimuth (°)	Height (m)	Raw (dBuV)	AF (dB)	CL (dB)	PA (dB)
AV	4.95678G	31.95	54.00	-22.05	1.25	3	Horizontal	94	1.46	30.70	33.14	5.36	37.25
PK	4.95392G	42.74	74.00	-31.26	1.23	3	Horizontal	94	1.46	41.51	33.12	5.36	37.25