

# RF TEST REPORT

Test item : DIGITAL CAR AVN SYSTEM  
Model No. : AN243DKAN, AN243DKKN  
Order No. : DEMC1307-02055, DEMC1307-02056  
Date of receipt : 2013-07-03  
Test duration : 2013-07-08 ~ 2013-07-12  
Date of issue : 2013-07-24  
Use of report : FCC Original Grant

Applicant : HYUNDAI MOBIS CO., LTD.  
80-9, Mabook-Dong, Giheung-Gu, Yongin-shi, Gyunggi-Do, 446-912, South Korea

Test laboratory : Digital EMC Co., Ltd.  
683-3, Yubang-Dong, Cheoin-Gu, Yongin-Si, Gyeonggi-Do, 449-080, Korea

Test specification : FCC Part 15 Subpart C.247  
RSS-210 Issue 8: 2010

Test environment : See appended test report

Test result :  Pass  Fail

The test results presented in this test report are limited only to the sample supplied by applicant and the use of this test report is inhibited other than its purpose. This test report shall not be reproduced except in full, without the written approval of DIGITAL EMC CO., LTD.

Tested by:



Engineer  
JaeJin Lee

Witnessed by:

N/A

Reviewed by:



Deputy General Manager  
HongHee Lee

## Test Report Version

Test Report No.	Date	Description
DRTFCC1307-0701	Jul. 24, 2013	Initial issue

## Table of Contents

<b>1. General Information .....</b>	<b>5</b>
<b>1.1 Testing Laboratory .....</b>	<b>5</b>
<b>1.2 Details of Applicant .....</b>	<b>5</b>
<b>1.3 Description of EUT .....</b>	<b>5</b>
<b>1.4 Declaration by the manufacturer .....</b>	<b>5</b>
<b>1.5 Information about the FHSS characteristics: .....</b>	<b>6</b>
<b>1.6 Test Equipment List .....</b>	<b>7</b>
<b>1.7 Summary of Test Results .....</b>	<b>8</b>
<b>1.8 Conclusion of worst-case and operation mode.....</b>	<b>9</b>
<b>2. Transmitter Radiated Spurious Emissions and Conducted Spurious Emission .....</b>	<b>10</b>
<b>2.1. Test Setup .....</b>	<b>10</b>
<b>2.2. Limit.....</b>	<b>10</b>
<b>2.3. Test Procedures.....</b>	<b>11</b>
<b>2.3.1. Test Procedures for Radiated Spurious Emissions.....</b>	<b>11</b>
<b>2.3.2. Test Procedures for Conducted Spurious Emissions .....</b>	<b>11</b>
<b>2.4. Test Results .....</b>	<b>12</b>
<b>2.4.1. Radiated Emission .....</b>	<b>12</b>
<b>2.4.2. Conducted Spurious Emissions .....</b>	<b>15</b>
<b>3. Carrier Frequency Separation.....</b>	<b>33</b>
<b>3.1. Test Setup .....</b>	<b>33</b>
<b>3.2. Limit.....</b>	<b>33</b>
<b>4. Number of Hopping Frequencies .....</b>	<b>38</b>
<b>4.1. Test Setup.....</b>	<b>38</b>
<b>4.2. Limit.....</b>	<b>38</b>
<b>5. 20dBc BW.....</b>	<b>47</b>
<b>5.1. Test Setup .....</b>	<b>47</b>
<b>5.2. Limit.....</b>	<b>47</b>
<b>5.3. Test Procedure .....</b>	<b>47</b>
<b>5.4. Test Results .....</b>	<b>47</b>
<b>6. Time of Occupancy (Dwell Time).....</b>	<b>53</b>
<b>6.1. Test Setup .....</b>	<b>53</b>
<b>6.2. Limit.....</b>	<b>53</b>
<b>6.3. Test Procedure .....</b>	<b>53</b>
<b>6.4. Test Results .....</b>	<b>53</b>
<b>7. Maximum Peak Output Power Measurement .....</b>	<b>58</b>
<b>7.1. Test Setup .....</b>	<b>58</b>
<b>7.2. Limit.....</b>	<b>58</b>
<b>7.3. Test Procedure.....</b>	<b>58</b>
<b>7.4. Test Results .....</b>	<b>59</b>
<b>8. Transmitter AC Power Line Conducted Emission .....</b>	<b>65</b>

<b>8.1. Test Setup .....</b>	<b>65</b>
<b>8.2. Limit.....</b>	<b>65</b>
<b>8.3. Test Procedures.....</b>	<b>65</b>
<b>8.4. Test Results .....</b>	<b>65</b>
<b>9. Antenna Requirement .....</b>	<b>66</b>
<b>10. Occupied Bandwidth(99%).....</b>	<b>67</b>
<b>APPENDIX I .....</b>	<b>74</b>

## 1. General Information

### 1.1 Testing Laboratory

**Digital EMC Co., Ltd.**

683-3, Yubang-Dong, Cheoin-Gu, Yongin-Si, Gyeonggi-Do, 449-080, Korea

[www.digitalemc.com](http://www.digitalemc.com)

Telephone : + 82-31-321-2664

FAX : + 82-31-321-1664

### 1.2 Details of Applicant

Applicant : HYUNDAI MOBIS CO., LTD.

Address : 80-9, Mabook-Dong, Giheung-Gu, Yongin-shi, Gyunggi-Do, 446-912, South Korea

Contact person : JongTae Kim

Phone No. : +82-31-260-0092

### 1.3 Description of EUT

<b>Product</b>	DIGITAL CAR AVN SYSTEM
<b>Model Name</b>	AN243DKAN, AN243DKKN Two models are same electrical and mechanical except following information - FCC Model name: AN243DKAN (FCC ID: TQ8-AN243DKAN) - IC Model name: AN243DKKN (IC: 5074A-AN243DKKN)
<b>Serial Number</b>	Identical prototype
<b>Power Supply</b>	DC 14.4 V
<b>Frequency Range</b>	2402 MHz ~ 2480 MHz
<b>Modulation Technique</b>	GFSK, $\pi/4$ -DQPSK, 8DPSK
<b>Number of Channels</b>	79
<b>Antenna Type</b>	PCB Antenna
<b>Antenna Gain</b>	PK : 1.0 dBi

### 1.4. Declaration by the manufacturer

- N/A

## 1.5. Information about the FHSS characteristics:

- This Bluetooth module has been tested by a Bluetooth Qualification Lab, and we confirm the following:
  - A) The hopping sequence is pseudorandom
  - B) All channels are used equally on average
  - C) The receiver input bandwidth equals the transmit bandwidth
  - D) The receiver hops in sequence with the transmit signal
- 15.247(g): In accordance with the Bluetooth Industry Standard, the system is designed to comply with all of the regulations in Section 15.247 when the transmitter is presented with a continuous data (or information) system.
- 15.247(h): In accordance with the Bluetooth Industry Standard, the system does not coordinate its channels selection/ hopping sequence with other frequency hopping systems for the express purpose of avoiding the simultaneous occupancy of individual hopping frequencies by multiple transmitters.
- 15.247(h): The EUT employs Adaptive Frequency Hopping (AFH) which identifies sources of interference namely devices operating in 802.11 WLAN and excludes them from the list of available channels. The process of re-mapping reduces the number of test channels from 79 channels to a minimum number of 20 channels.

### 1.6. Test Equipment List

Type	Manufacturer	Model	Cal.Date (yy/mm/dd)	Next.Cal.Date (yy/mm/dd)	S/N
Horn Antenna	ETS	3115	13/02/28	15/02/28	00021097
Multimeter	HP	34401A	13/02/27	14/02/27	3146A13475
System DC Power Supply	HP	6633A	13/02/27	14/02/27	3524A06634
Vector Signal Generator	Rohde Schwarz	SMBV100A	13/01/08	14/01/08	255571
Horn Antenna	A.H.Systems Inc.	SAS-574	13/03/20	15/03/20	154
Thermohygrometer	BODYCOM	BJ5478	13/01/14	14/01/14	090205-4
High-pass Filter	Wainwright Instruments	WHKX3.0	12/09/17	13/09/17	9
PreAmplifier	Agilent	8449B	13/02/27	14/02/27	3008A00370
3dB Attenuator	Aeroflex/Weinschel	56-3	12/09/17	13/09/17	Y2342
Spectrum Analyzer	Agilent Technologies	E4440A	12/10/22	13/10/22	US45303051
Loop Antenna	Schwarzbeck	FMZB1513	12/09/24	13/09/24	1513-128
Signal Generator	Rohde Schwarz	SMR40	12/09/19	13/09/19	100546
MXA Signal Analyzer	Agilent	N9020A	13/04/10	14/04/10	MY50200816
BILOG ANTENNA	SCHAFFNER	CBL6112B	12/11/06	14/11/06	2737
Amplifier	HP	8447E	13/01/08	14/01/08	2945A02865
EMI TEST RECEIVER	Rohde Schwarz	ESU	13/01/08	14/01/08	100014

### 1.7. Summary of Test Results

FCC Part RSS-210 & GEN	Parameter	Limit (Using in 2400~ 2483.5MHz)	Test Condition	Status Note 1
15.247(a) RSS-210(A8.1)	Carrier Frequency Separation	>= 20dB BW or >= Two-Thirds of the 20dB BW	Conducted	<b>C</b>
	Number of Hopping Frequencies	>= 15 hops		<b>C</b>
	20 dB Bandwidth	None		<b>C</b>
	Dwell Time	=< 0.4 seconds		<b>C</b>
15.247(b) RSS-210(A8.4)	Transmitter Output Power	=< 1Watt , if CHs >= 75 Others =<0.125W		<b>C</b>
15.247(d) RSS-210(A8.5)	Band-edge	The radiated emission to any 100 kHz of out-band shall be at least 20dB below the highest in-band spectral density.	<b>C</b>	
	Conducted Spurious Emissions		<b>C</b>	
15.205 15.209 RSS-210(A8.5)	RadiatedEmissions	FCC 15.209 Limits	Radiated	<b>C</b> Note.2
15.207 RSS-Gen(7.2.4)	AC Conducted Emissions	FCC 15.207 Limits	AC Line Conducted	<b>NA</b> Note. 3
15.203 RSS-Gen(7.1.2)	Antenna Requirements	FCC 15.203	-	<b>C</b>
<p>Note 1: C=Comply NC=Not Comply NT=Not Tested NA=Not Applicable</p> <p>Note 2:The sample was tested according to the following specification:                      ANSI C63.4-2009, DA00-705, RSS-Gen Issue 3: 2010</p> <p>Note 3: This device is installed in a car. Therefore the power source is a battery of car.</p>				



### 1.8 Conclusion of worst-case and operation mode

The EUT has three type of modulation (GFSK,  $\pi/4$ DQPSK and 8DPSK).

Therefore all applicable requirements were tested with all the modulations.

The field strength of spurious emission was measured in three orthogonal EUT positions(X-axis, Y-axis and Z-axis).

Tested frequency information,

- Hopping Function: Enable

	TX Frequency(MHz)	RX Frequency(MHz)
<b>Hopping Band</b>	2402 ~ 2480	2402 ~ 2480

- Hopping Function: Disable

	TX Frequency(MHz)	RX Frequency(MHz)
<b>Lowest Channel</b>	2402	2402
<b>Middle Channel</b>	2441	2441
<b>Highest Channel</b>	2480	2480

## 2. Transmitter Radiated Spurious Emissions and Conducted Spurious Emission

### 2.1. Test Setup

Refer to the APPENDIX I.

### 2.2. Limit

According to §15.247(d), in any 100 kHz bandwidth outside the frequency band in which the spread spectrum or digitally modulated intentional radiator is operating, the radio frequency power that is produced by the intentional radiator shall be at least 20 dB below that in the 100 kHz bandwidth within the band that contains the highest level of the desired power, based on either an RF conducted or a radiated measurement, provided the transmitter demonstrates compliance with the peak conducted power limits. If the transmitter complies with the conducted power limits based on the use of RMS averaging over a time interval, as permitted under paragraph(b)(3) of this section, the attenuation required under this paragraph shall be 30 dB instead of 20 dB. Attenuation below the general limits specified in section §15.209(a) is not required. In addition, radiated emission which in the restricted band, as define in section §15.205(a), must also comply the radiated emission limits specified in section §15.209(a) (see section §15.205(c))

According to § 15.209(a), except as provided elsewhere in this Subpart, the emissions from an intentional radiator shall not exceed the field strength levels specified in the following table

Frequency (MHz)	Limit (uV/m)	Measurement Distance (meter)
0.009 – 0.490	2400/F(KHz)	300
0.490 – 1.705	24000/F(KHz)	30
1.705 – 30.0	30	30
30 ~ 88	100 **	3
88 ~ 216	150 **	3
216 ~ 960	200 **	3
Above 960	500	3

\*\* Except as provided in 15.209(g), fundamental emissions from intentional radiators operating under this Section shall not be located in the frequency bands 54-72 MHz, 76-88MHz, 174-216MHz or 470-806MHz. However, operation within these frequency bands is permitted under other sections of this Part, e.g. 15.231 and 15.241.

According to § 15.205(a) and (b), only spurious emissions are permitted in any of the frequency bands listed below:

MHz	MHz	MHz	MHz	GHz	GHz
0.009 ~ 0.110	8.41425 ~ 8.41475	108 ~ 121.94	1300 ~ 1427	3600 ~ 4400	14.47 ~ 14.5
0.495 ~ 0.505	12.29 ~ 12.293	123 ~ 138	1435 ~ 1626.5	4.5 ~ 5.15	15.35 ~ 16.2
2.1735 ~ 2.1905	12.51975 ~ 12.52025	149.9 ~ 150.05	1645.5 ~ 1646.5	5.35 ~ 5.46	17.7 ~ 21.4
4.125 ~ 4.128	12.57675 ~ 12.57725	156.52475 ~	1660 ~ 1710	7.25 ~ 7.75	22.01 ~ 23.12
4.17725 ~ 4.17775	13.36 ~ 13.41	156.52525	1718.8 ~ 1722.2	8.025 ~ 8.5	23.6 ~ 24.0
4.20725 ~ 4.20775	16.42 ~ 16.423	156.7 ~ 156.9	2200 ~ 2300	9.0 ~ 9.2	31.2 ~ 31.8
6.215 ~ 6.218	16.69475 ~ 16.69525	162.0125 ~ 167.17	2310 ~ 2390	9.3 ~ 9.5	36.43 ~ 36.5
6.26775 ~ 6.26825	16.80425 ~ 16.80475	167.72 ~ 173.2	2483.5 ~ 2500	10.6 ~ 12.7	Above 38.6
6.31175 ~ 6.31225	25.5 ~ 25.67	240 ~ 285	2655 ~ 2900	13.25 ~ 13.4	
8.291 ~ 8.294	37.5 ~ 38.25	322 ~ 335.4	3260 ~ 3267		
8.362 ~ 8.366	73 ~ 74.6	399.90 ~ 410	3332 ~ 3339		
8.37625 ~ 8.38675	74.8 ~ 75.2	608 ~ 614	3345.8 ~ 3358		
		960 ~ 1240			

The field strength of emissions appearing within these frequency bands shall not exceed the limits shown in §15.209. At frequencies equal to or less than 1000 MHz, compliance with the limits in §15.209 shall be demonstrated using measurement instrumentation employing a CISPR quasi-peak detector. Above 1000 MHz, compliance with the emission limits in §15.209 shall be demonstrated based on the average value of the measured emissions. The provisions in §15.35 apply to these measurements.

## 2.3. Test Procedures

Radiated emissions from the EUT were measured according to the DA 00-705 and ANSI C63.4:2009

### 2.3.1. Test Procedures for Radiated Spurious Emissions

1. The EUT was placed on the top of a rotating table 0.8 meters above the ground at a 3 meter anechoic chamber test site. The table was rotated 360 degrees to determine the position of the highest radiation.
2. During performing radiated emission below 1 GHz, the EUT was set 3 meters away from the interference receiving antenna, which was mounted on the top of a variable-height antenna tower. During performing radiated emission above 1 GHz, the EUT was set 3 meter away from the interference-receiving antenna.
3. The antenna is a broadband antenna, and its height is varied from one meter to four meters above the ground to determine the maximum value of the field strength. Both horizontal and vertical polarizations of the antenna are set to make the measurement.
4. For each suspected emission, the EUT was arranged to its worst case and then the antenna was tuned to heights from 1 meter to 4 meters and the table was turned from 0 degrees to 360 degrees to find the maximum reading.
5. The test-receiver system was set to Peak Detect Function and Specified Bandwidth with Maximum Hold Mode.
6. If the emission level of the EUT in peak mode was 10 dB lower than the limit specified, then testing could be stopped and the peak values of the EUT would be reported. Otherwise the emissions that did not have 10 dB margin would be re-tested one by one using peak, quasi-peak or average method as specified and then reported in a data sheet.

NOTE ;

1. The resolution bandwidth and video bandwidth of test receiver/spectrum analyzer is 120 kHz for Quasi-peak detection (QP) at frequency below 1 GHz.
2. The resolution bandwidth and video bandwidth of test receiver/spectrum analyzer is 1 MHz for Peak detection and frequency above 1 GHz.
3. The resolution bandwidth of test receiver/spectrum analyzer is 1 MHz and the video bandwidth is 1 kHz for Average detection (AV) at frequency above 1 GHz.

### 2.3.2. Test Procedures for Conducted Spurious Emissions

1. The transmitter output was connected to the spectrum analyzer.
2. The **reference level** of the fundamental frequency was measured with the spectrum analyzer using RBW=100 kHz, VBW=300 kHz.
3. The conducted spurious emission was tested each ranges were set as below.

**Frequency range : 9KHz ~ 30MHz**

**RBW= 100kHz, VBW= 300kHz, SWEEP TIME = AUTO, DETECTOR = PEAK, TRACE = MAX HOLD, Sweep point : 5001**

**Frequency range : 30MHz~10GHz, 10GHz~25GHz**

**RBW= 1 MHz, VBW= 3 MHz, SWEEP TIME = AUTO, DETECTOR = PEAK, TRACE = MAX HOLD, SPAN = MAX 3 GHz (Below 10 GHz) and MAX 5 GHz (Above 10 GHz) , BINS = at least 2001 (Each 1GHz range)**

If the emission level with above setting was close to the limit (i.e., less than 3 dB margin) then zoom scan is required using RBW = 100 KHz, VBW = 300KHz, SAPN = 100 MHz and BINS = 1001 to get accurate emission level within 100 KHz BW.

## 2.4. Test Results

Ambient temperature : 21°C  
 Relative humidity : 54%

### 2.4.1. Radiated Emission

#### 9KHz ~ 25GHz Data(Modulation: GFSK)

##### ▪ Lowest Channel

Frequency (MHz)	ANT Pol	The worst case EUT Position (Axis)	Detect or Mode	Reading (dBuV)	T.F (dB/m)	D.C.F. (dB)	Distance Factor(dB)	Result (dBuV/m)	Limit (dBuV/m)	Margin (dB)
2388.72	H	X	PK	47.56	-3.38	N/A	N/A	44.18	74.00	29.82
2388.84	H	X	AV	37.09	-3.38	N/A	N/A	33.71	54.00	20.29
4804.10	H	X	PK	45.73	5.39	N/A	N/A	51.12	74.00	22.88
4803.90	H	X	AV	33.66	5.39	N/A	N/A	39.05	54.00	14.95

##### ▪ Middle Channel

Frequency (MHz)	ANT Pol	The worst case EUT Position (Axis)	Detect or Mode	Reading (dBuV)	T.F (dB/m)	D.C.F. (dB)	Distance Factor(dB)	Result (dBuV/m)	Limit (dBuV/m)	Margin (dB)
4881.84	H	X	PK	44.31	5.67	N/A	N/A	49.98	74.00	24.02
4882.01	H	X	AV	32.94	5.67	N/A	N/A	38.61	54.00	15.39

##### ▪ Highest Channel

Frequency (MHz)	ANT Pol	The worst case EUT Position (Axis)	Detect or Mode	Reading (dBuV)	T.F (dB/m)	D.C.F. (dB)	Distance Factor(dB)	Result (dBuV/m)	Limit (dBuV/m)	Margin (dB)
2483.52	H	X	PK	65.46	-2.79	N/A	N/A	62.67	74.00	11.33
2483.80	H	X	AV	39.07	-2.79	N/A	N/A	36.28	54.00	17.72
4959.63	H	X	PK	45.57	6.04	N/A	N/A	51.61	74.00	22.39
4959.88	H	X	AV	33.20	6.04	N/A	N/A	39.24	54.00	14.76

#### Note.

1. No other spurious and harmonic emissions were found greater than listed emissions on above table.
2. Above listed point data is the worst case data.
3. Sample Calculation.

$$\text{Margin} = \text{Limit} - \text{Result} \quad / \quad \text{Result} = \text{Reading} + \text{T.F} + \text{D.C.F.} \quad / \quad \text{T.F} = \text{AF} + \text{CL} - \text{AG}$$

Where, T.F = Total Factor, AF = Antenna Factor, CL = Cable Loss, AG = Amplifier Gain,

4. D.C.F Calculation. (D.C.F. = Duty Cycle Correction Factor)

- Time to cycle through all channels=  $\Delta t = \tau_{[ms]} \times 79$  channels, where  $\tau$  = pulse width

-  $100ms / \Delta t_{[ms]} = H$  -> Round up to next highest integer, to account for worst case, H'

- The Worst Case Dwell Time =  $\tau_{[ms]} \times H'$  (For this case, H' = 1,  $\tau = 2.89$  ms,  $1 \times 2.89 = 2.89$ )

- D.C.F =  $20 \times \text{Log}(\text{The Worst Case Dwell Time} / 100ms)$  dB =  $20 \times \text{Log}(2.89/100) = -30.78$  dB

**9KHz ~ 25GHz Data(Modulation:  $\pi/4$ DQPSK)**

▪ **Lowest Channel**

Frequency (MHz)	ANT Pol	The worst case EUT Position (Axis)	Detect or Mode	Reading (dBuV)	T.F (dB/m)	D.C.F. (dB)	Distance Factor(dB)	Result (dBuV/m)	Limit (dBuV/m)	Margin (dB)
2375.92	H	X	PK	48.27	-3.38	N/A	N/A	44.89	74.00	29.11
2375.84	H	X	AV	36.84	-3.38	N/A	N/A	33.46	54.00	20.54
4803.45	H	X	PK	44.90	5.39	N/A	N/A	50.29	74.00	23.71
4803.52	H	X	AV	31.29	5.39	N/A	N/A	36.68	54.00	17.32

▪ **Middle Channel**

Frequency (MHz)	ANT Pol	The worst case EUT Position (Axis)	Detect or Mode	Reading (dBuV)	T.F (dB/m)	D.C.F. (dB)	Distance Factor(dB)	Result (dBuV/m)	Limit (dBuV/m)	Margin (dB)
4881.86	H	X	PK	43.94	5.67	N/A	N/A	49.61	74.00	24.39
4882.22	H	X	AV	31.21	5.67	N/A	N/A	36.88	54.00	17.12

▪ **Highest Channel**

Frequency (MHz)	ANT Pol	The worst case EUT Position (Axis)	Detect or Mode	Reading (dBuV)	T.F (dB/m)	D.C.F. (dB)	Distance Factor(dB)	Result (dBuV/m)	Limit (dBuV/m)	Margin (dB)
2483.53	H	X	PK	65.10	-2.79	N/A	N/A	62.31	74.00	11.69
2483.72	H	X	AV	39.02	-2.79	N/A	N/A	36.23	54.00	17.77
4959.45	H	X	PK	44.46	6.04	N/A	N/A	50.50	74.00	23.50
4960.07	H	X	AV	31.59	6.04	N/A	N/A	37.63	54.00	16.37

**Note.**

1. No other spurious and harmonic emissions were found greater than listed emissions on above table.
2. Above listed point data is the worst case data.
3. Sample Calculation.

$$\text{Margin} = \text{Limit} - \text{Result} \quad / \quad \text{Result} = \text{Reading} + \text{T.F} + \text{D.C.F.} \quad / \quad \text{T.F} = \text{AF} + \text{CL} - \text{AG}$$

Where, T.F = Total Factor, AF = Antenna Factor, CL = Cable Loss, AG = Amplifier Gain,

4. D.C.F Calculation. (D.C.F. = Duty Cycle Correction Factor)

- Time to cycle through all channels=  $\Delta t = \tau_{[ms]} \times 79$  channels, where  $\tau$  = pulse width
- $100ms / \Delta t_{[ms]} = H$  -> Round up to next highest integer, to account for worst case, H'
- The Worst Case Dwell Time =  $\tau_{[ms]} \times H'$  (For this case,  $H' = 1$ ,  $\tau = 2.89$  ms,  $1 \times 2.89 = 2.89$ )
- D.C.F =  $20 \times \text{Log}(\text{The Worst Case Dwell Time} / 100ms)$  dB =  $20 \times \text{Log}(2.89/100) = -30.78$  dB

**9KHz ~ 25GHz Data(Modulation: 8DPSK)**

▪ **Lowest Channel**

Frequency (MHz)	ANT Pol	The worst case EUT Position (Axis)	Detect or Mode	Reading (dBuV)	T.F (dB/m)	D.C.F. (dB)	Distance Factor(dB)	Result (dBuV/m)	Limit (dBuV/m)	Margin (dB)
2375.84	H	X	PK	48.25	-3.38	N/A	N/A	44.87	74.00	29.13
2376.40	H	X	AV	36.29	-3.38	N/A	N/A	32.91	54.00	21.09
4803.72	H	X	PK	43.90	5.39	N/A	N/A	49.29	74.00	24.71
4803.64	H	X	AV	31.35	5.39	N/A	N/A	36.74	54.00	17.26

▪ **Middle Channel**

Frequency (MHz)	ANT Pol	The worst case EUT Position (Axis)	Detect or Mode	Reading (dBuV)	T.F (dB/m)	D.C.F. (dB)	Distance Factor(dB)	Result (dBuV/m)	Limit (dBuV/m)	Margin (dB)
4882.16	H	X	PK	43.86	5.67	N/A	N/A	49.53	74.00	24.47
4881.97	H	X	AV	31.14	5.67	N/A	N/A	36.81	54.00	17.19

▪ **Highest Channel**

Frequency (MHz)	ANT Pol	The worst case EUT Position (Axis)	Detect or Mode	Reading (dBuV)	T.F (dB/m)	D.C.F. (dB)	Distance Factor(dB)	Result (dBuV/m)	Limit (dBuV/m)	Margin (dB)
2483.53	H	X	PK	65.17	-2.79	N/A	N/A	62.38	74.00	11.62
2483.98	H	X	AV	39.17	-2.79	N/A	N/A	36.38	54.00	17.62
4959.85	H	X	PK	44.22	6.04	N/A	N/A	50.26	74.00	23.74
4959.70	H	X	AV	31.60	6.04	N/A	N/A	37.64	54.00	16.36

**Note.**

1. No other spurious and harmonic emissions were found greater than listed emissions on above table.
2. Above listed point data is the worst case data.
3. Sample Calculation.

$$\text{Margin} = \text{Limit} - \text{Result} \quad / \quad \text{Result} = \text{Reading} + \text{T.F} + \text{D.C.F.} \quad / \quad \text{T.F} = \text{AF} + \text{CL} - \text{AG}$$

Where, T.F = Total Factor, AF = Antenna Factor, CL = Cable Loss, AG = Amplifier Gain,

4. D.C.F Calculation. (D.C.F. = Duty Cycle Correction Factor)

- Time to cycle through all channels=  $\Delta t = \tau_{[ms]} \times 79$  channels , where  $\tau$  = pulse width
- $100ms / \Delta t_{[ms]} = H \rightarrow$  Round up to next highest integer, to account for worst case, H'
- The Worst Case Dwell Time =  $\tau_{[ms]} \times H'$  (For this case,  $H' = 1, \tau = 2.89$  ms,  $1 \times 2.89 = 2.89$ )
- D.C.F =  $20 \times \text{Log}(\text{The Worst Case Dwell Time} / 100ms)$  dB =  $20 \times \text{Log}(2.89/100) = -30.78$  dB

## 2.4.2. Conducted Spurious Emissions

### Low Band-edge

### Lowest Channel & Modulation: GFSK



### Low Band-edge

### Hopping mode & Modulation: GFSK



**Conducted Spurious Emissions**

**Lowest Channel** & Modulation: **GFSK**

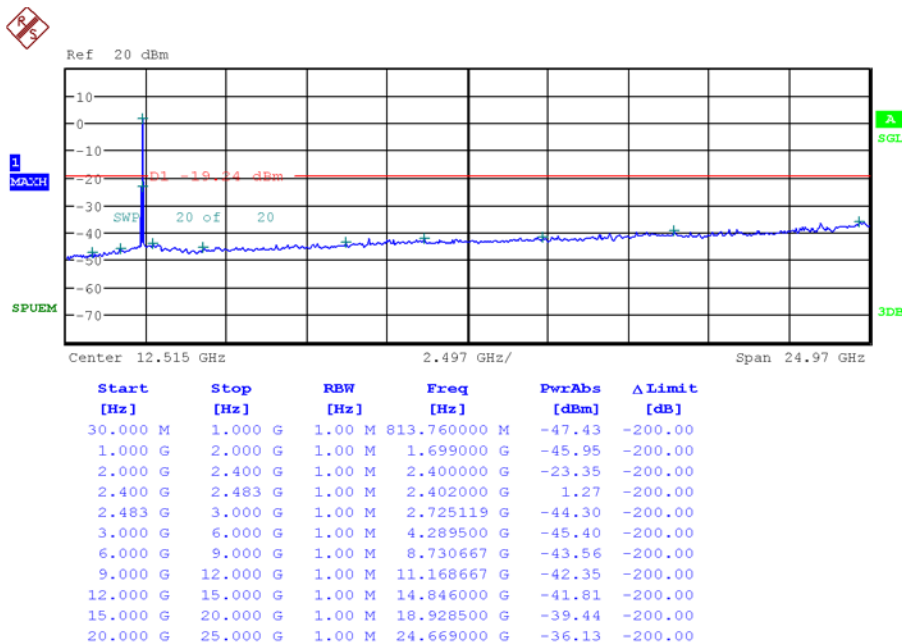
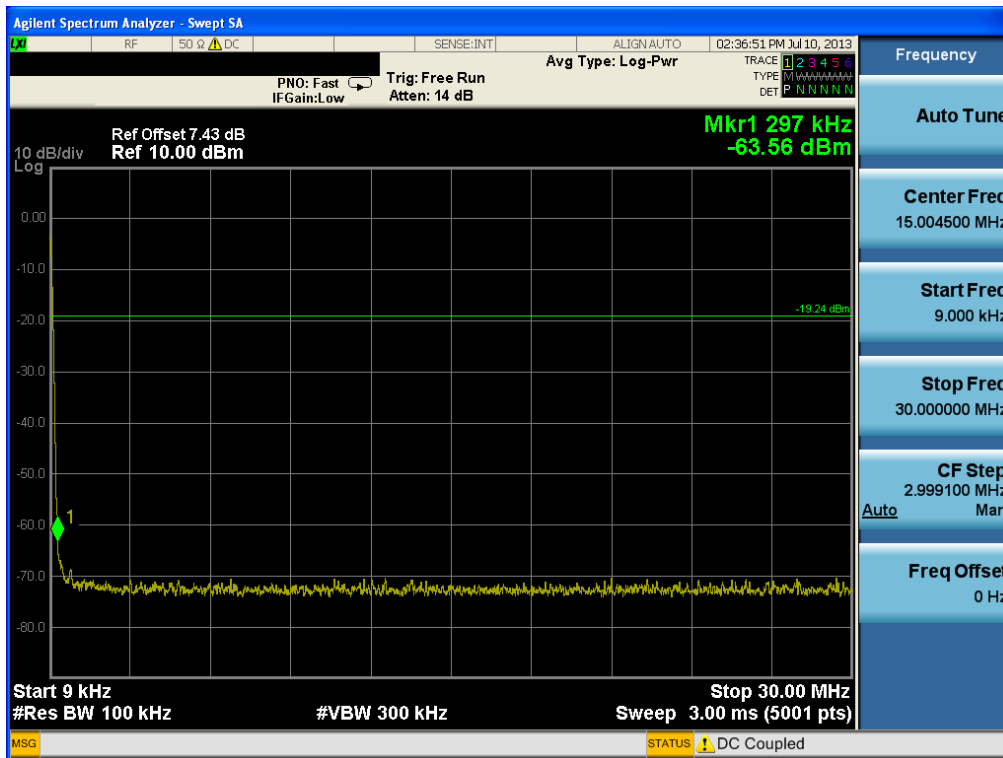



**Reference for limit**

**Middle Channel & Modulation: GFSK**

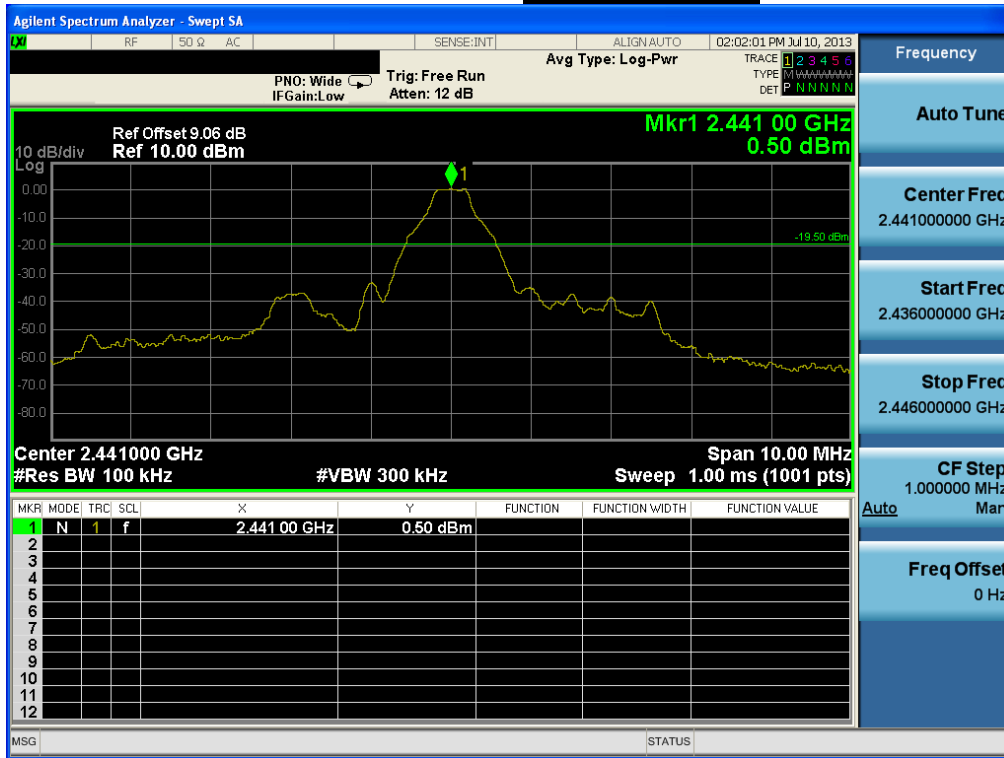

**Conducted Spurious Emissions**

**Middle Channel & Modulation: GFSK**

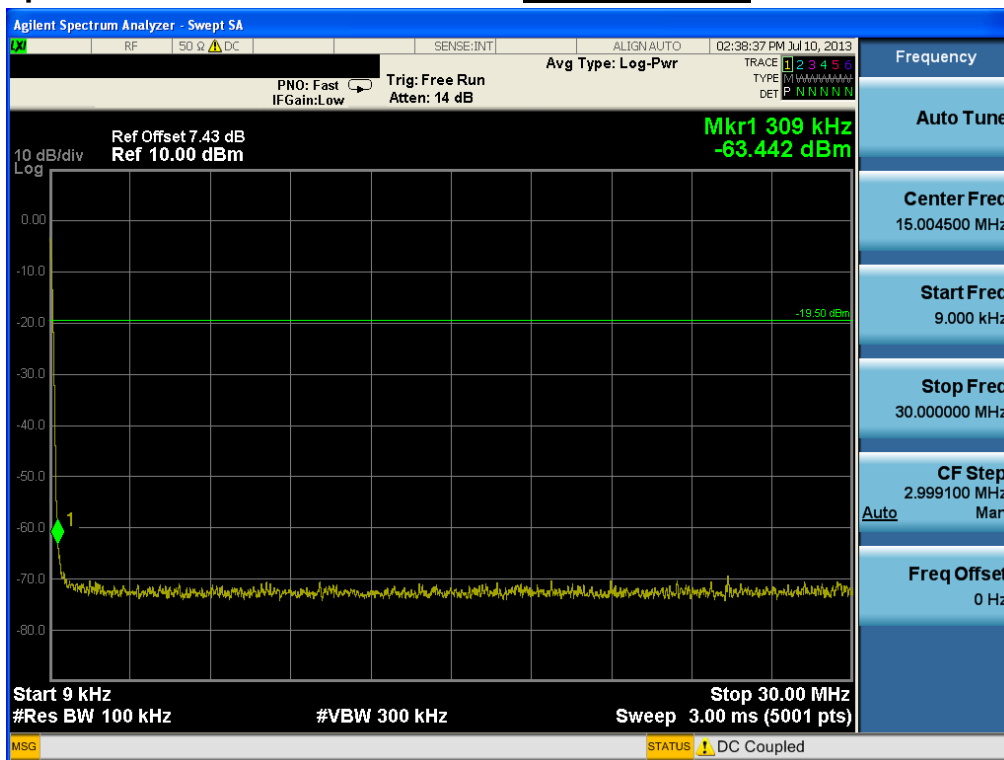

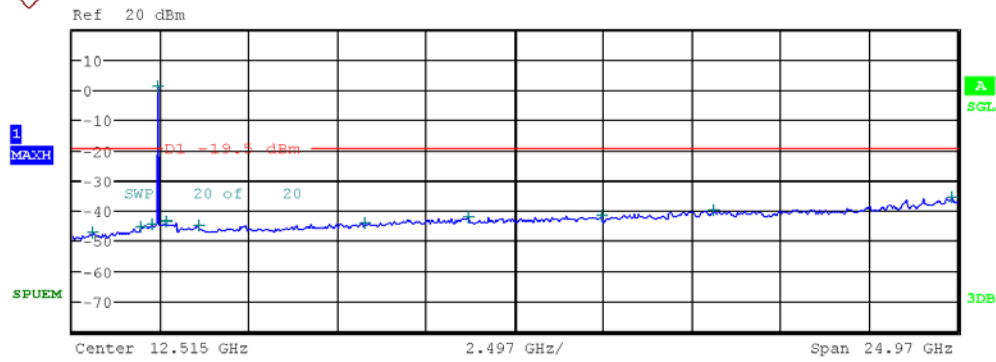

Start [Hz]	Stop [Hz]	RBW [Hz]	Freq [Hz]	PwrAbs [dBm]	ΔLimit [dB]
30.000 M	1.000 G	1.00 M	578.535000 M	-47.54	-200.00
1.000 G	2.000 G	1.00 M	1.940000 G	-45.30	-200.00
2.000 G	2.400 G	1.00 M	2.283200 G	-44.55	-200.00
2.400 G	2.483 G	1.00 M	2.440898 G	0.87	-200.00
2.483 G	3.000 G	1.00 M	2.659265 G	-43.68	-200.00
3.000 G	6.000 G	1.00 M	3.592500 G	-45.18	-200.00
6.000 G	9.000 G	1.00 M	8.265000 G	-44.04	-200.00
9.000 G	12.000 G	1.00 M	11.181333 G	-42.18	-200.00
12.000 G	15.000 G	1.00 M	14.947667 G	-41.81	-200.00
15.000 G	20.000 G	1.00 M	18.100000 G	-40.02	-200.00
20.000 G	25.000 G	1.00 M	24.845500 G	-35.83	-200.00

**High Band-edge**

**Highest Channel** & Modulation: **GFSK**



**High Band-edge**

**Hopping mode** & Modulation: **GFSK**



**Conducted Spurious Emissions**

**Highest Channel** & Modulation: **GFSK**

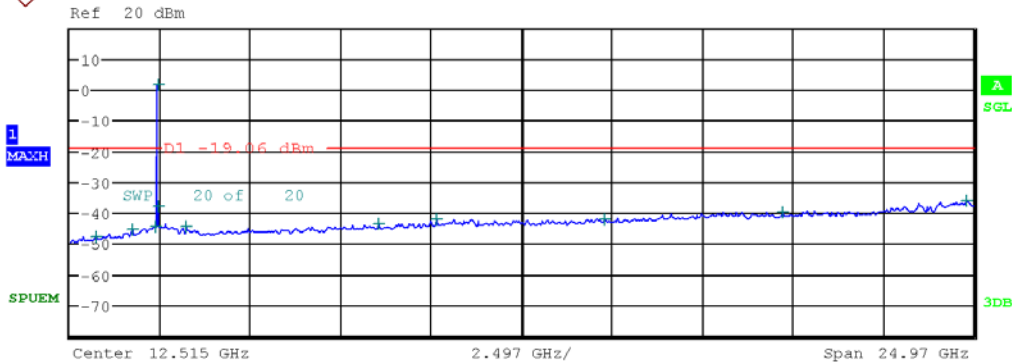
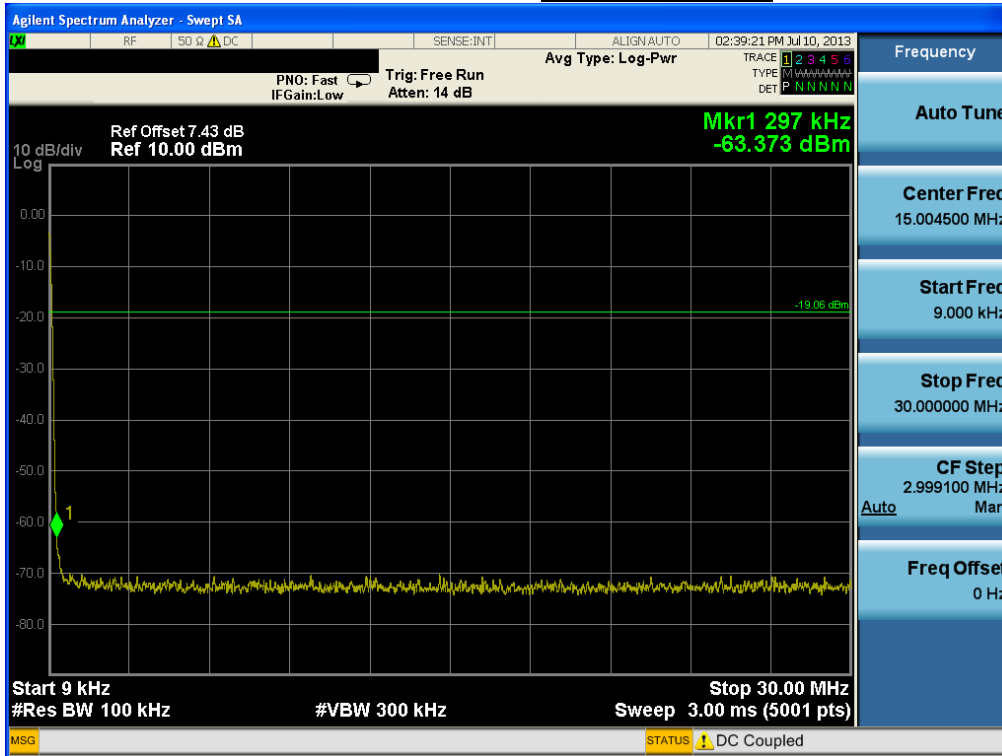

Start [Hz]	Stop [Hz]	RBW [Hz]	Freq [Hz]	PwrAbs [dBm]	Δ Limit [dB]
30.000 M	1.000 G	1.00 M	742.950000 M	-47.62	-200.00
1.000 G	2.000 G	1.00 M	1.735000 G	-45.63	-200.00
2.000 G	2.400 G	1.00 M	2.375120 G	-44.60	-200.00
2.400 G	2.483 G	1.00 M	2.479993 G	1.38	-200.00
2.483 G	3.000 G	1.00 M	2.483500 G	-37.89	-200.00
3.000 G	6.000 G	1.00 M	3.235500 G	-44.72	-200.00
6.000 G	9.000 G	1.00 M	8.553000 G	-43.48	-200.00
9.000 G	12.000 G	1.00 M	10.145333 G	-42.12	-200.00
12.000 G	15.000 G	1.00 M	14.787000 G	-42.19	-200.00
15.000 G	20.000 G	1.00 M	19.737000 G	-39.93	-200.00
20.000 G	25.000 G	1.00 M	24.786000 G	-36.00	-200.00

**Low Band-edge**

**Lowest Channel & Modulation:  $\pi/4$ QPSK**



**Low Band-edge**

**Hopping mode & Modulation:  $\pi/4$ QPSK**

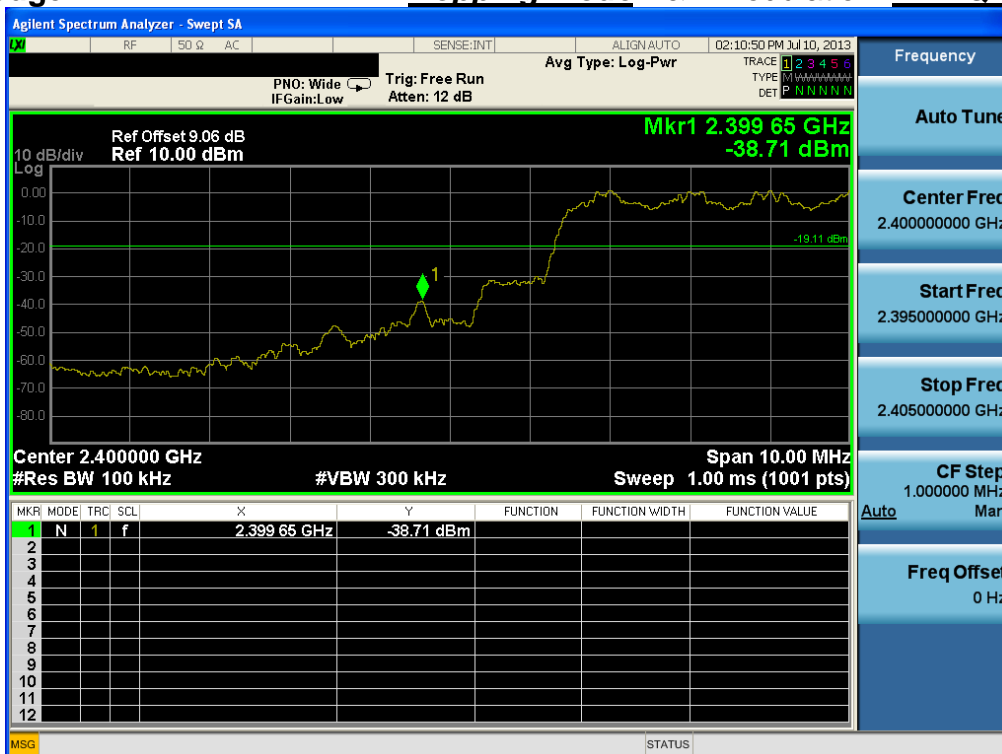

### Conducted Spurious Emissions

### Lowest Channel & Modulation: $\pi/4$ DQPSK

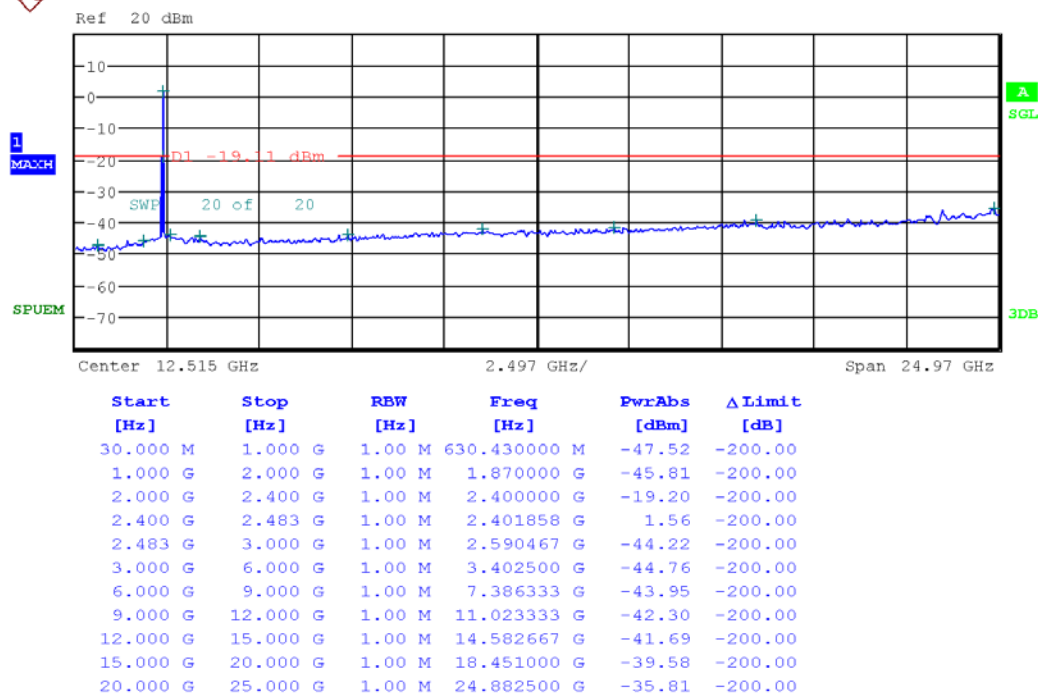
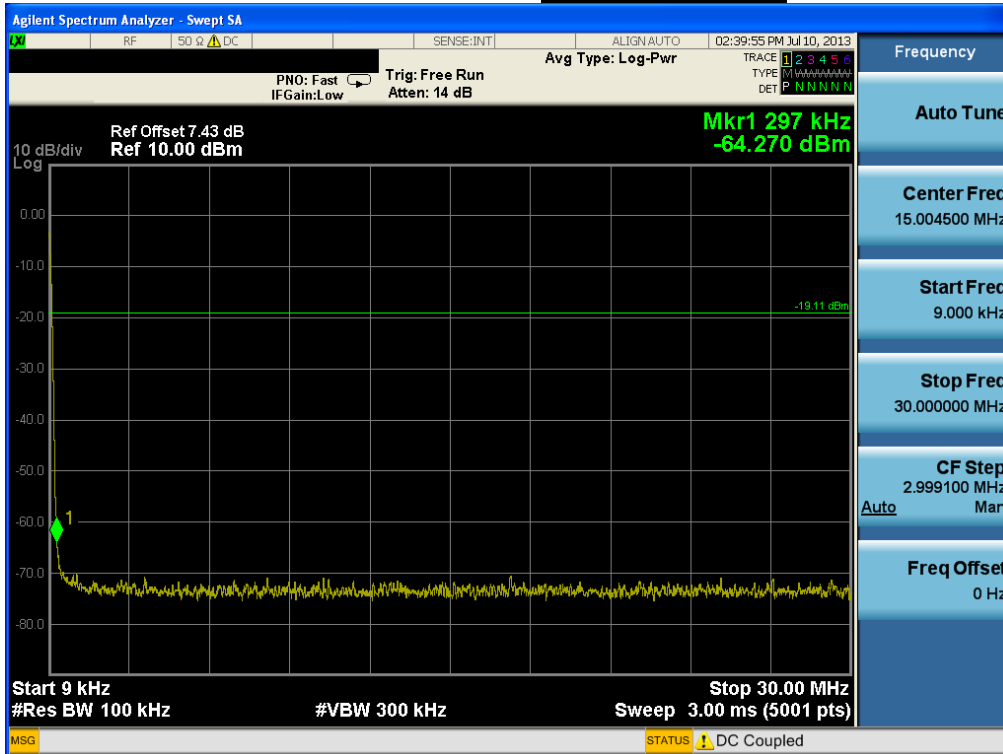

**Reference for limit**

**Middle Channel & Modulation:  $\pi/4$ DQPSK**

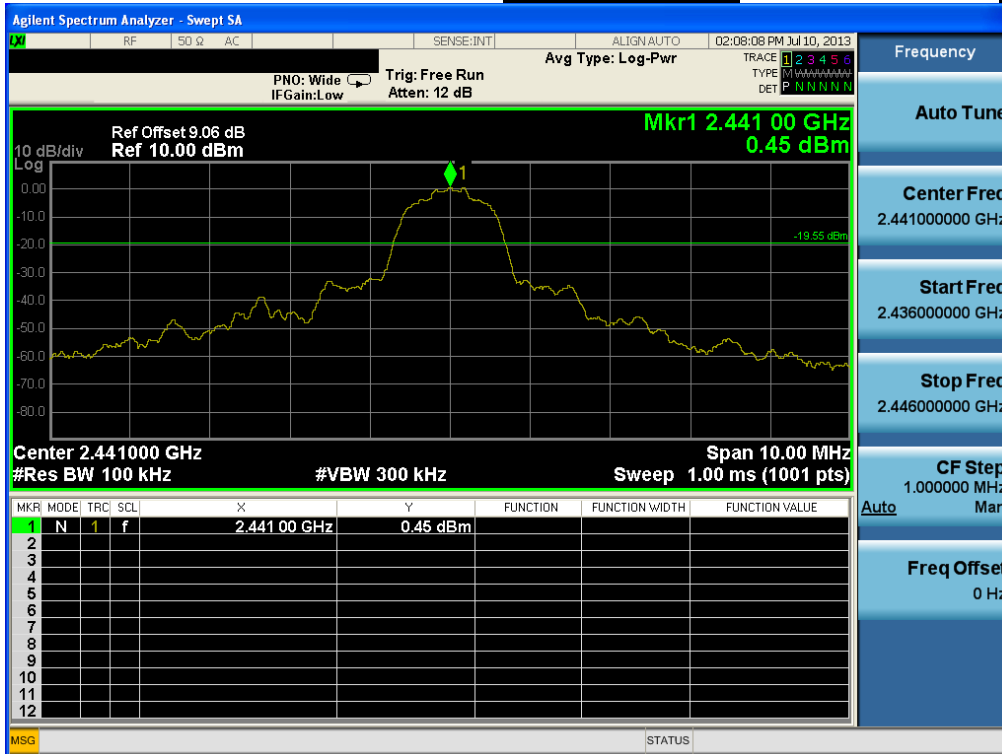

**Conducted Spurious Emissions**

**Middle Channel & Modulation:  $\pi/4$ DQPSK**

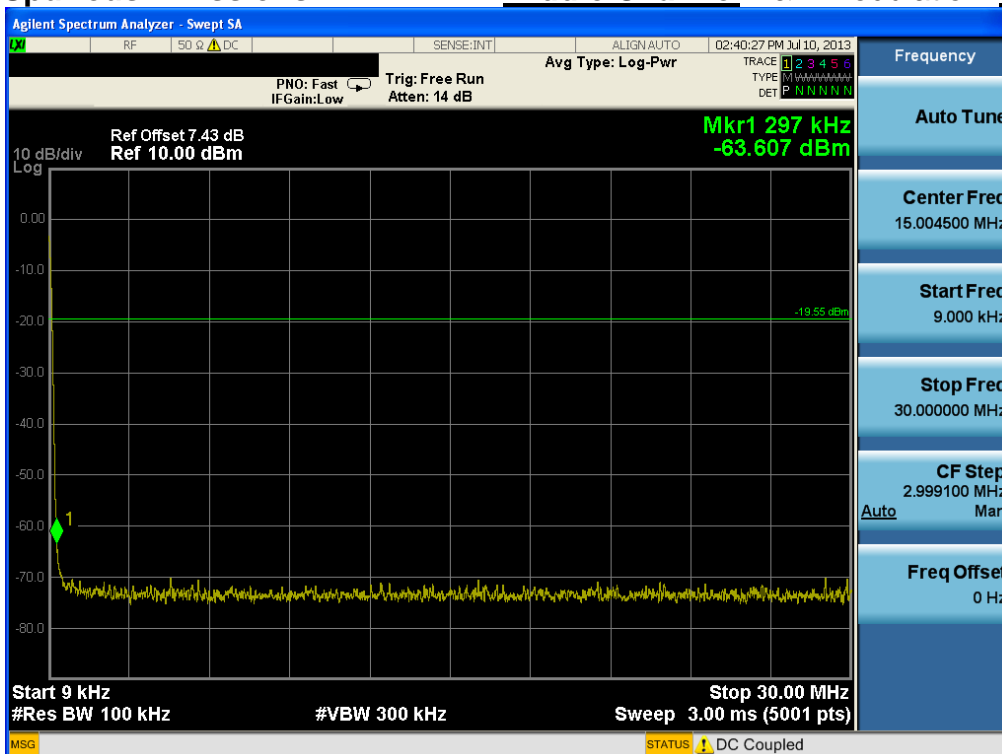

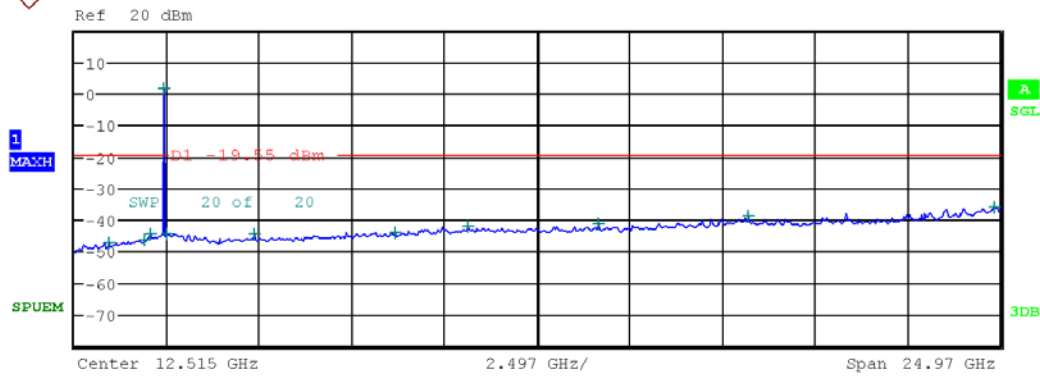

Start [Hz]	Stop [Hz]	RBW [Hz]	Freq [Hz]	PwrAbs [dBm]	Δ Limit [dB]
30.000 M	1.000 G	1.00 M	936.950000 M	-47.58	-200.00
1.000 G	2.000 G	1.00 M	1.911500 G	-46.54	-200.00
2.000 G	2.400 G	1.00 M	2.070880 G	-44.71	-200.00
2.400 G	2.483 G	1.00 M	2.441111 G	1.25	-200.00
2.483 G	3.000 G	1.00 M	2.528229 G	-44.51	-200.00
3.000 G	6.000 G	1.00 M	4.882500 G	-44.68	-200.00
6.000 G	9.000 G	1.00 M	8.670667 G	-44.19	-200.00
9.000 G	12.000 G	1.00 M	10.624000 G	-42.26	-200.00
12.000 G	15.000 G	1.00 M	14.137000 G	-41.25	-200.00
15.000 G	20.000 G	1.00 M	18.192500 G	-38.95	-200.00
20.000 G	25.000 G	1.00 M	24.853000 G	-36.10	-200.00



**High Band-edge**

**Highest Channel & Modulation:  $\pi/4$ DQPSK**



Frequency
Auto Tune
Center Freq 2.48350000 GHz
Start Freq 2.47850000 GHz
Stop Freq 2.48850000 GHz
CF Step 1.000000 MHz Man
Freq Offset 0 Hz

**High Band-edge**

**Hopping mode & Modulation:  $\pi/4$ DQPSK**



Frequency
Auto Tune
Center Freq 2.48350000 GHz
Start Freq 2.47850000 GHz
Stop Freq 2.48850000 GHz
CF Step 1.000000 MHz Man
Freq Offset 0 Hz

**Conducted Spurious Emissions**

**Highest Channel & Modulation:  $\pi/4$ DQPSK**

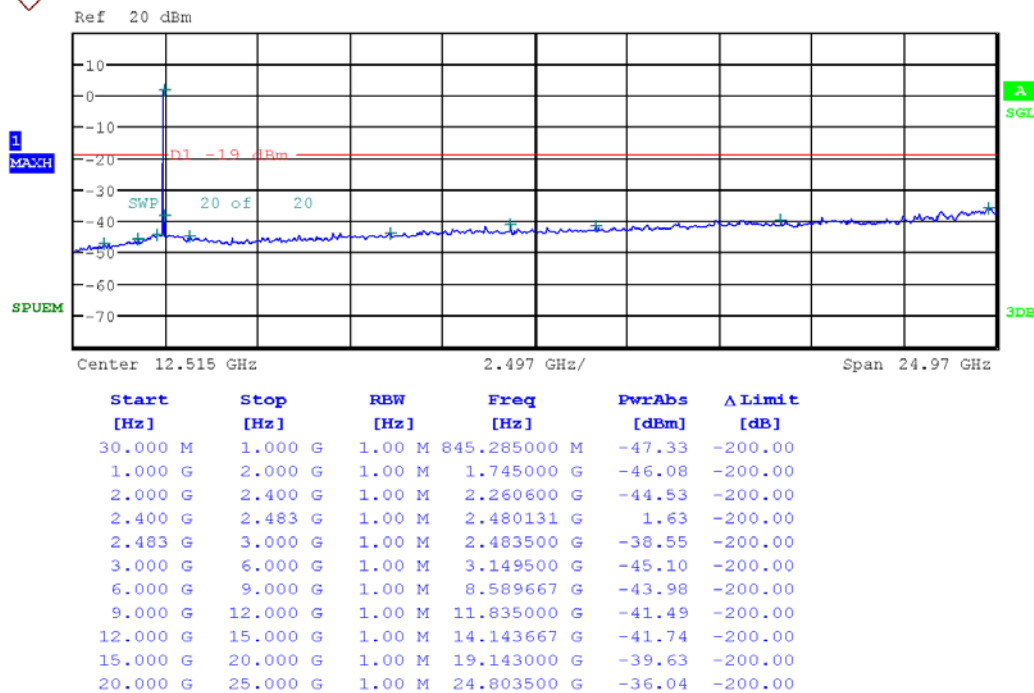
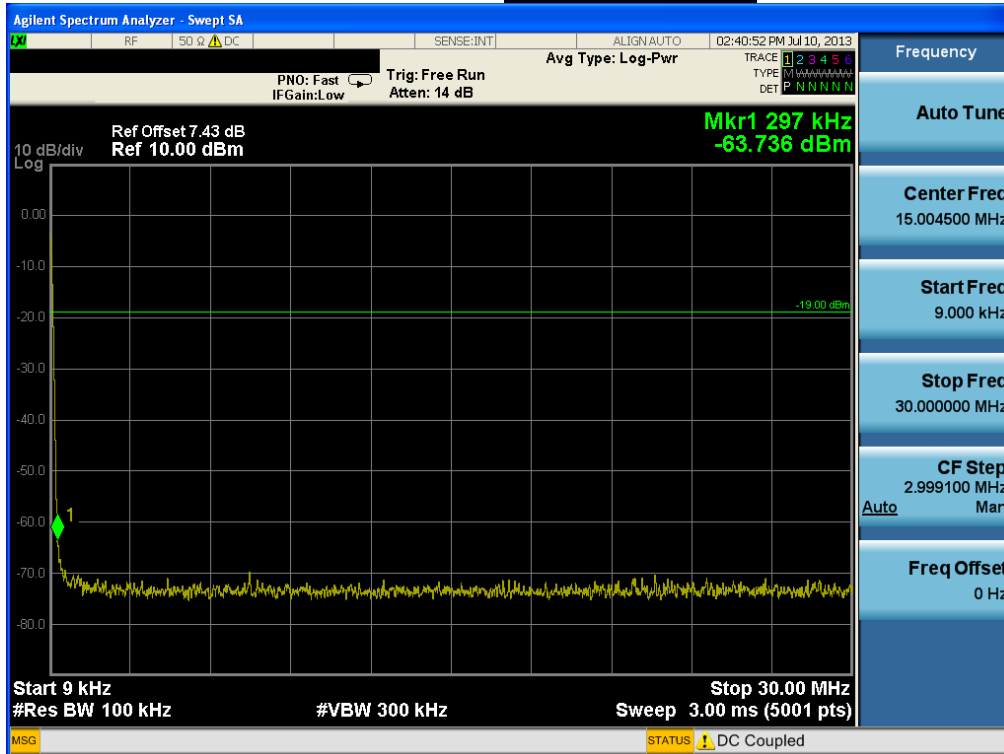

**Low Band-edge**

***Lowest Channel* & Modulation: *8DPSK***

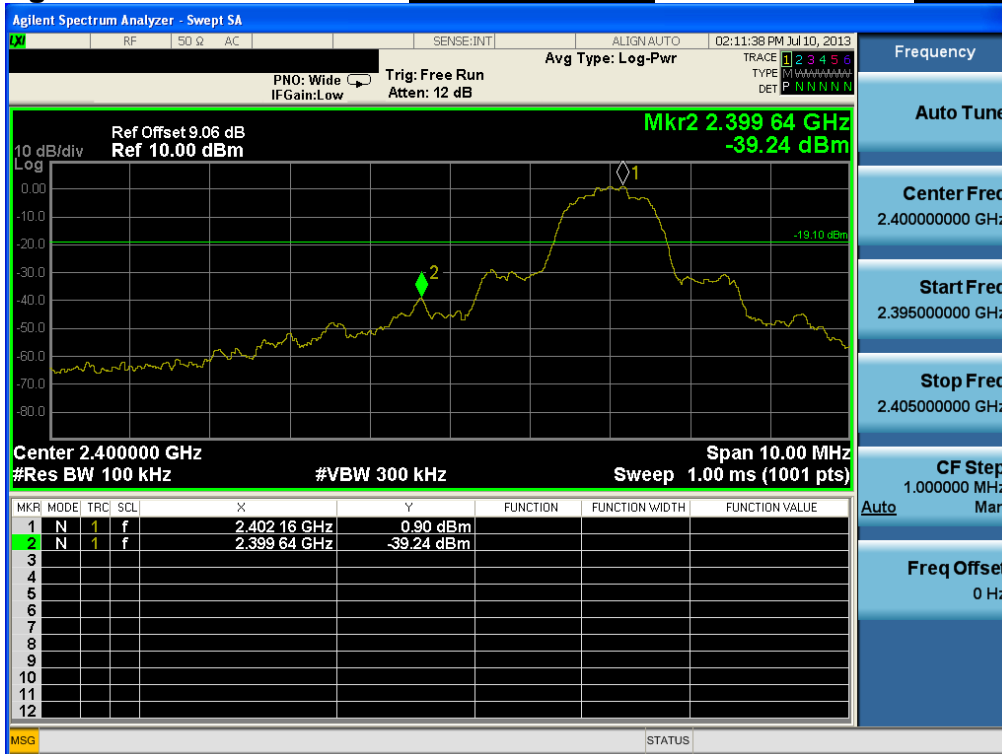

**Low Band-edge**

***Hopping mode* & Modulation: *8DPSK***



**Conducted Spurious Emissions**

**Lowest Channel** & Modulation: **8DPSK**

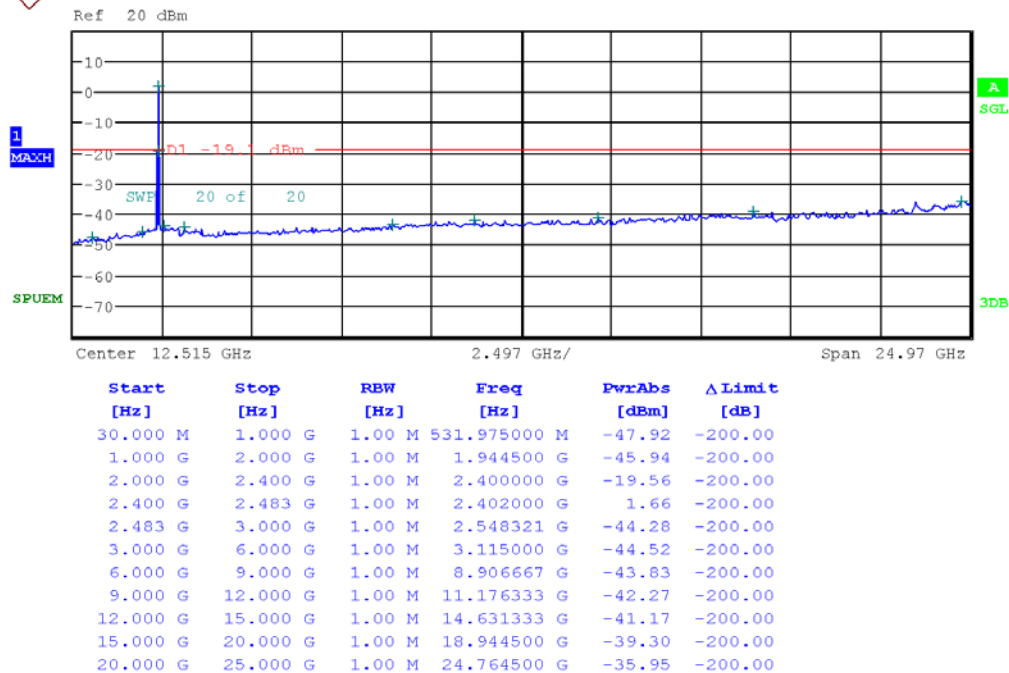
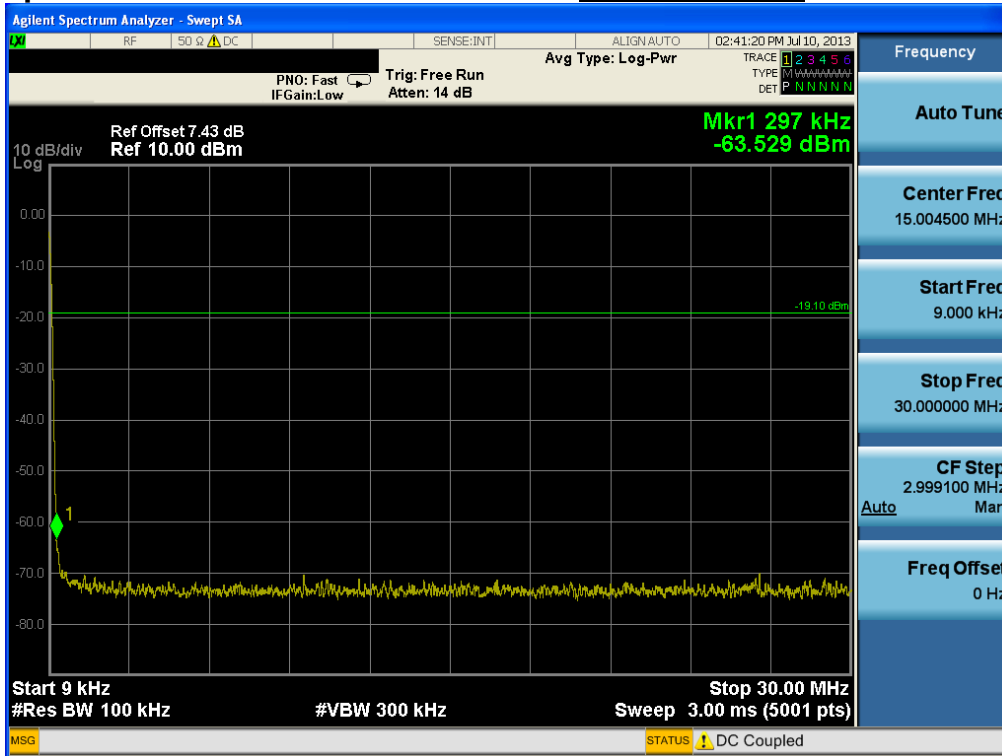

**Reference for limit**

**Middle Channel & Modulation: 8DPSK**

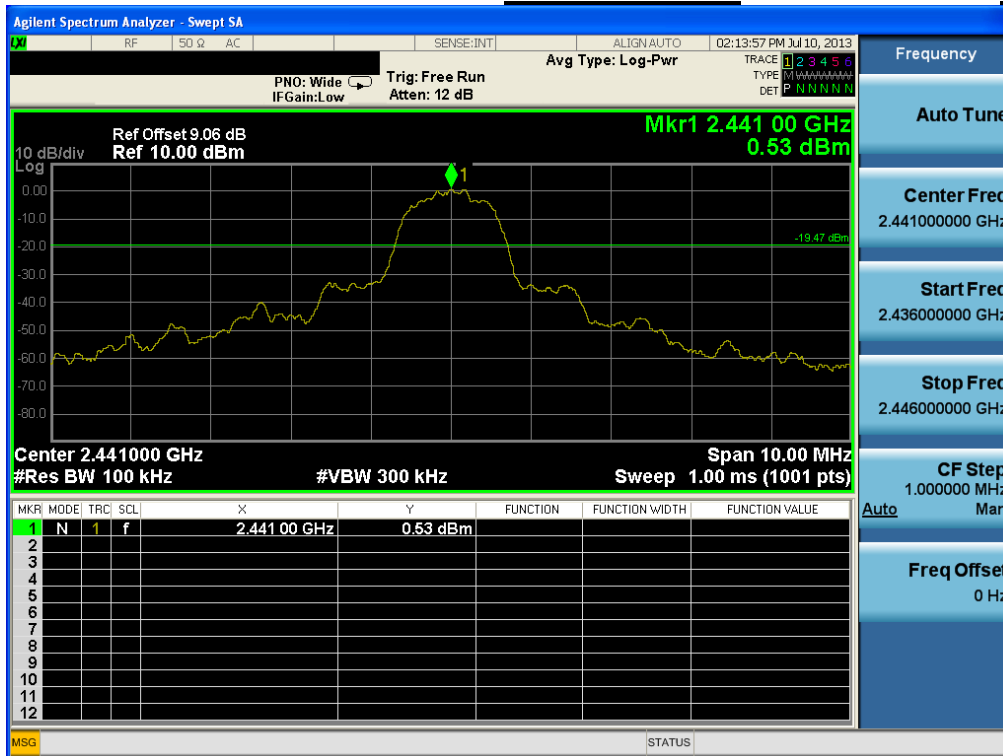

**Conducted Spurious Emissions**

**Middle Channel & Modulation: 8DPSK**

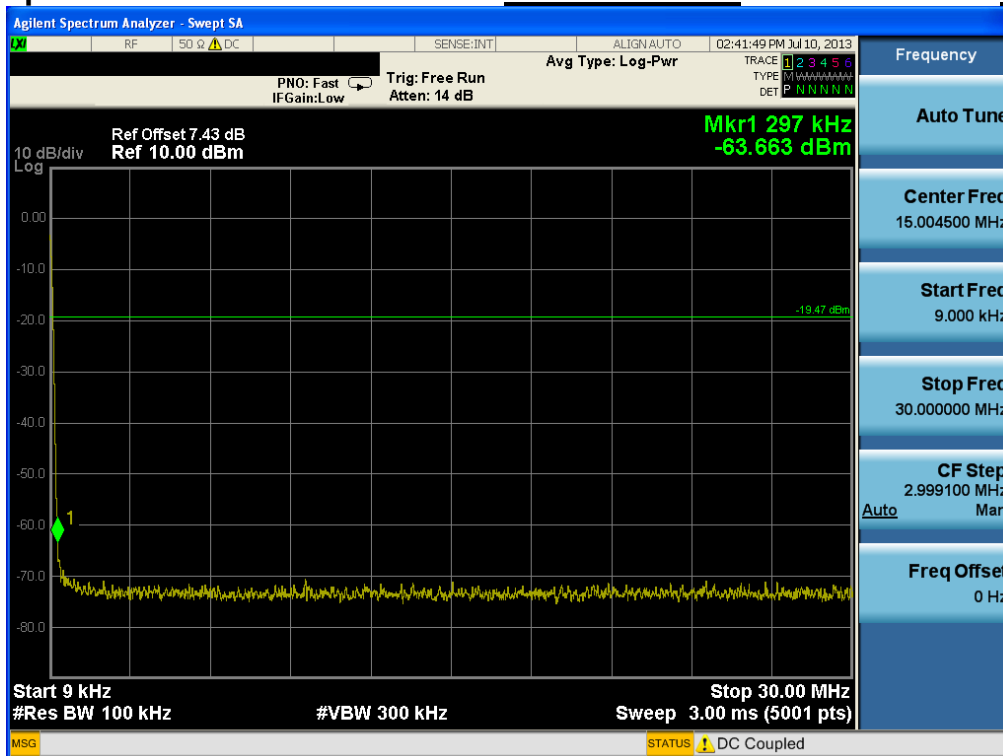

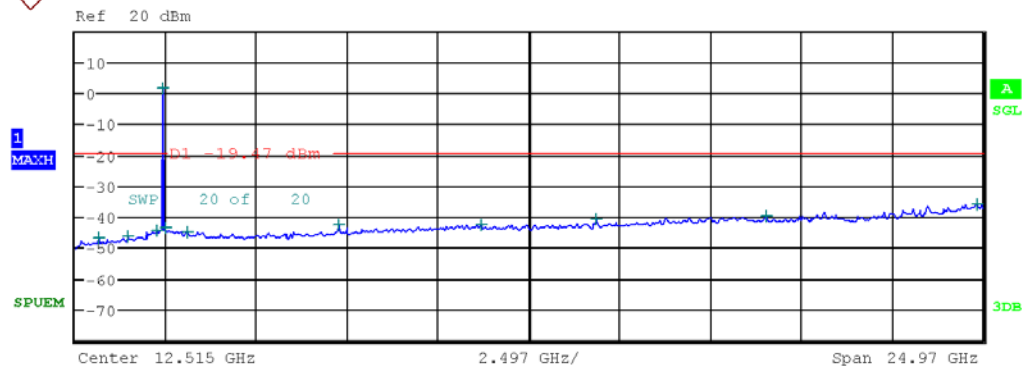

Center 12.515 GHz      2.497 GHz/      Span 24.97 GHz

Start [Hz]	Stop [Hz]	RBW [Hz]	Freq [Hz]	PwrAbs [dBm]	Δ Limit [dB]
30.000 M	1.000 G	1.00 M	662.440000 M	-47.13	-200.00
1.000 G	2.000 G	1.00 M	1.461000 G	-46.37	-200.00
2.000 G	2.400 G	1.00 M	2.282600 G	-44.45	-200.00
2.400 G	2.483 G	1.00 M	2.441036 G	1.37	-200.00
2.483 G	3.000 G	1.00 M	2.522031 G	-43.53	-200.00
3.000 G	6.000 G	1.00 M	3.097000 G	-45.16	-200.00
6.000 G	9.000 G	1.00 M	7.280000 G	-42.52	-200.00
9.000 G	12.000 G	1.00 M	11.188667 G	-42.56	-200.00
12.000 G	15.000 G	1.00 M	14.357333 G	-40.94	-200.00
15.000 G	20.000 G	1.00 M	19.029000 G	-39.69	-200.00
20.000 G	25.000 G	1.00 M	24.821500 G	-35.89	-200.00

**High Band-edge**

***Highest Channel*** & Modulation: **8DPSK**



**High Band-edge**

***Hopping mode*** & Modulation: **8DPSK**



### Conducted Spurious Emissions

**Highest Channel** & Modulation: **8DPSK**

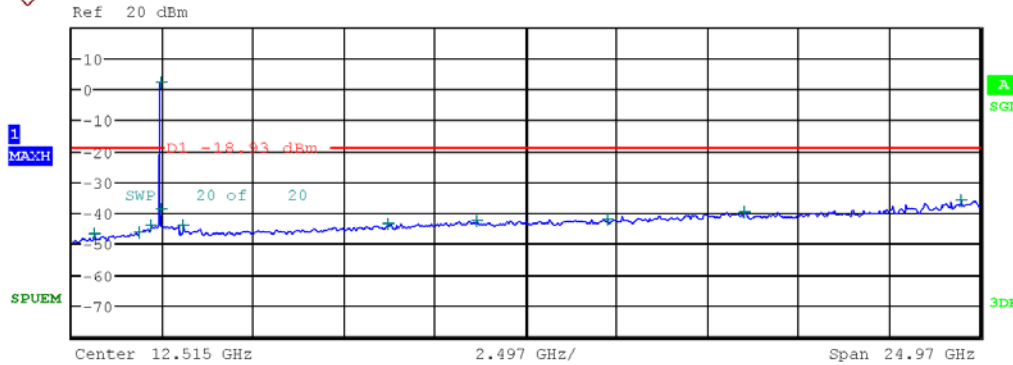
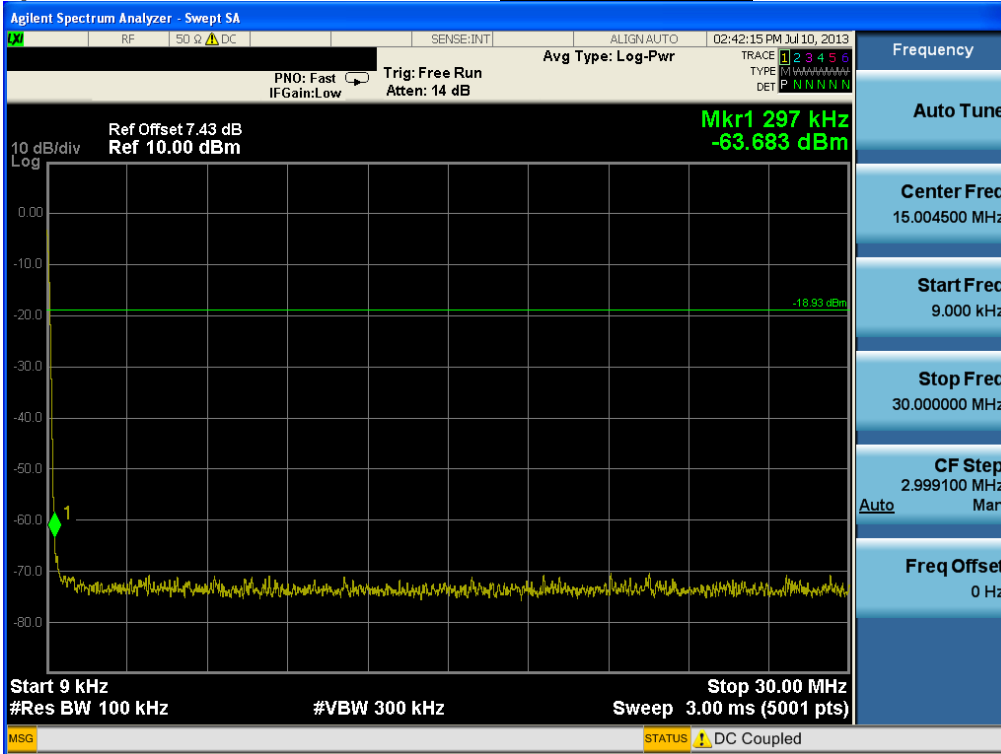

Start [Hz]	Stop [Hz]	RBW [Hz]	Freq [Hz]	PwrAbs [dBm]	Δ Limit [dB]
30.000 M	1.000 G	1.00 M	649.345000 M	-47.13	-200.00
1.000 G	2.000 G	1.00 M	1.858500 G	-46.33	-200.00
2.000 G	2.400 G	1.00 M	2.175200 G	-43.96	-200.00
2.400 G	2.483 G	1.00 M	2.480006 G	1.78	-200.00
2.483 G	3.000 G	1.00 M	2.483552 G	-38.72	-200.00
3.000 G	6.000 G	1.00 M	3.079500 G	-44.03	-200.00
6.000 G	9.000 G	1.00 M	8.723667 G	-43.54	-200.00
9.000 G	12.000 G	1.00 M	11.141333 G	-42.73	-200.00
12.000 G	15.000 G	1.00 M	14.761333 G	-42.10	-200.00
15.000 G	20.000 G	1.00 M	18.508500 G	-39.71	-200.00
20.000 G	25.000 G	1.00 M	24.493000 G	-35.95	-200.00



### 3. Carrier Frequency Separation

#### 3.1. Test Setup

Refer to the APPENDIX I.

#### 3.2. Limit

Limit:  $\geq 20\text{dB BW}$  or  $\geq \text{Two-Thirds of the } 20\text{dB BW}$

**- Procedure:**

The carrier frequency separation was measured with a spectrum analyzer connected to the antenna terminal, while EUT had its hopping function enabled.

After the trace being stable, the reading value between the peaks of the adjacent channels using the marker-delta function was recorded as the measurement results.

The spectrum analyzer is set to:

- Span = wide enough to capture the peaks of two adjacent channels
- RBW = 1% of the span
- VBW =  $\geq$  RBW
- Trace = max hold
- Sweep = auto
- Detector function = peak

**- Measurement Data: Comply**

**- FH mode**

Hopping Mode	Test Mode	Peak of adjacent Channel (MHz)	Peak of center channel (MHz)	Test Result (MHz)
Enable	GFSK	2441.000	2442.002	1.002
	$\pi/4$ DQPSK	2440.994	2441.999	1.005
	8DPSK	2440.994	2441.996	1.002

**- AFH mode**

Hopping Mode	Test Mode	Peak of adjacent Channel (MHz)	Peak of center channel (MHz)	Test Result (MHz)
Enable	GFSK	2409.992	2401.000	1.008
	$\pi/4$ DQPSK	2409.998	2411.000	1.002
	8DPSK	2410.991	2411.993	1.002

Note 1: See next pages for actual measured spectrum plots.

**- Minimum Standard:**

Frequency hopping systems shall have hopping channel carrier frequencies separated by a minimum of 25 kHz or the 20 dB bandwidth of the hopping channel, whichever is greater.  
 Alternatively, frequency hopping systems operating in the 2400-2483.5 MHz band may have hopping channel carrier frequencies that are separated by 25 kHz or two-thirds of the 20 dB bandwidth of the hopping channel, whichever is greater, provided the systems operate with an output power no greater than 125 mW

**Carrier Frequency Separation (FH) Hopping mode: Enable & Modulation: GFSK**



**Carrier Frequency Separation (FH) Hopping mode: Enable & Modulation:  $\pi/4$ DQPSK**



**Carrier Frequency Separation (FH)**

Hopping mode: Enable & Modulation: 8DPSK



**Carrier Frequency Separation (AFH) Hopping mode: Enable & Modulation: GFSK**

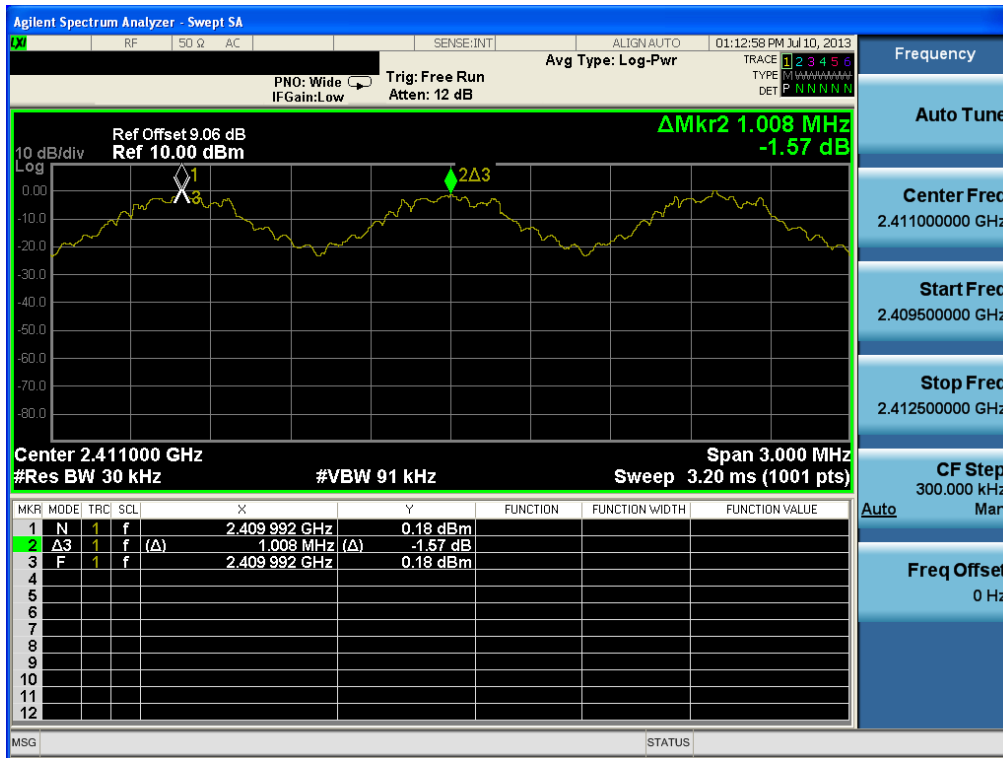

**Carrier Frequency Separation (AFH) Hopping mode: Enable & Modulation:  $\pi/4$ DQPSK**

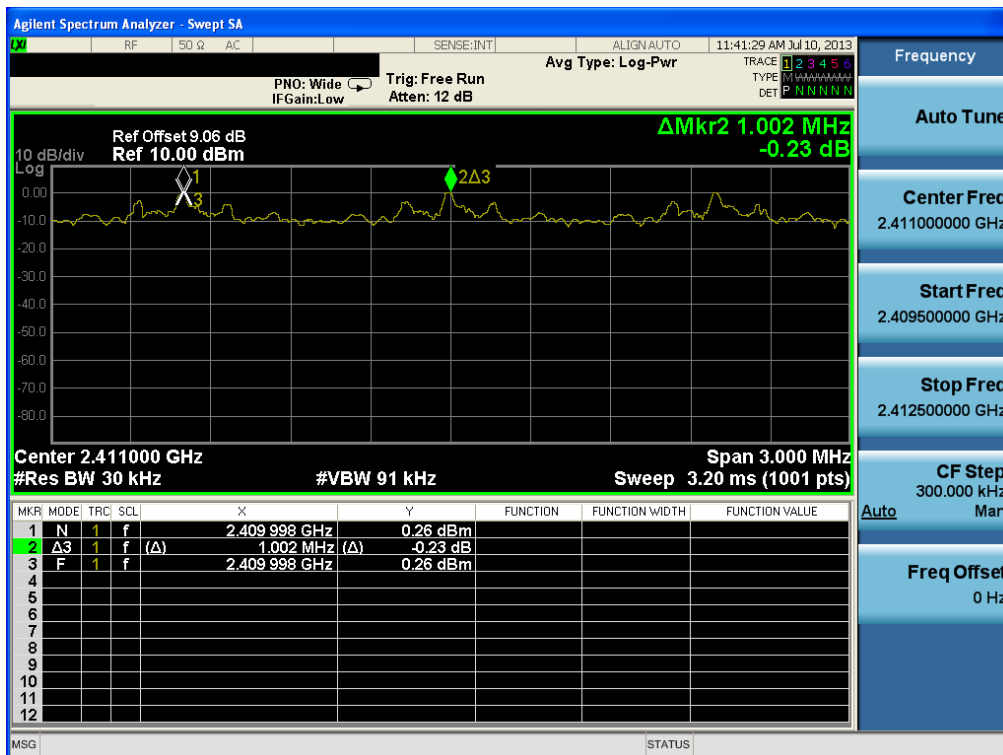

**Carrier Frequency Separation (AFH) Hopping mode: Enable & Modulation: 8DPSK**

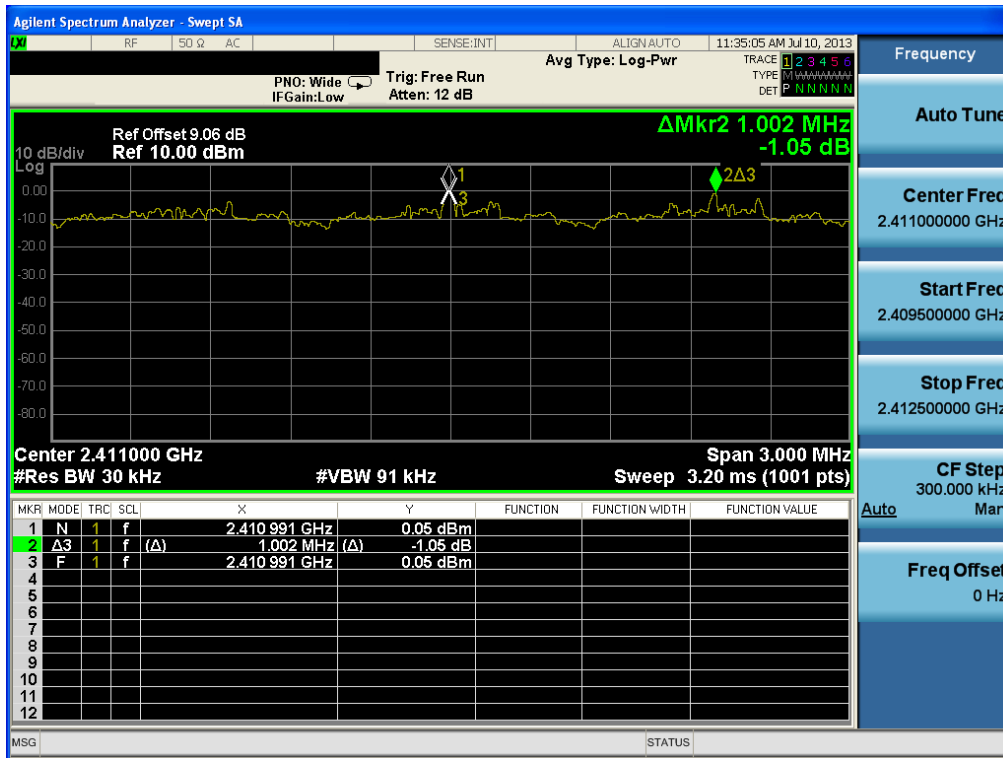

## 4. Number of Hopping Frequencies

### 4.1. Test Setup

Refer to the APPENDIX I.

### 4.2. Limit

Limit: >= 15 hops

#### - Procedure:

The number of hopping frequencies was measured with a spectrum analyzer connected to the antenna terminal, while EUT had its hopping function enabled.

To get higher resolution, four frequency ranges within the 2400 ~ 2483.5 MHz FH band were examined.

The spectrum analyzer is set to:

Span = 25MHz      Plot 1: Start Frequency = 2389.5MHz,    Stop Frequency = 2414.5 MHz

Plot 2: Start Frequency = 2414.5MHz,    Stop Frequency = 2439.5 MHz

Plot 3: Start Frequency = 2439.5MHz,    Stop Frequency = 2464.5 MHz

Plot 4: Start Frequency = 2464.5MHz,    Stop Frequency = 2489.5 MHz

RBW = 1% of the span or more

Sweep = auto

VBW = ≥ RBW

Detector function = peak

Trace = max hold

#### - Measurement Data: **Comply**

#### - FH mode

Hopping mode	Test mode	Test Result (Total Hops)
Enable	GFSK	79
	$\pi/4$ DQPSK	79
	8DPSK	79

#### - AFH mode

Hopping mode	Test mode	Test Result (Total Hops)
Enable	GFSK	20
	$\pi/4$ DQPSK	20
	8DPSK	20

Note 1: See next pages for actual measured spectrum plots.

#### - Minimum Standard:

At least 15 hops

**Number of Hopping Frequencies 1(FH)** Hopping mode: Enable & Modulation: GFSK

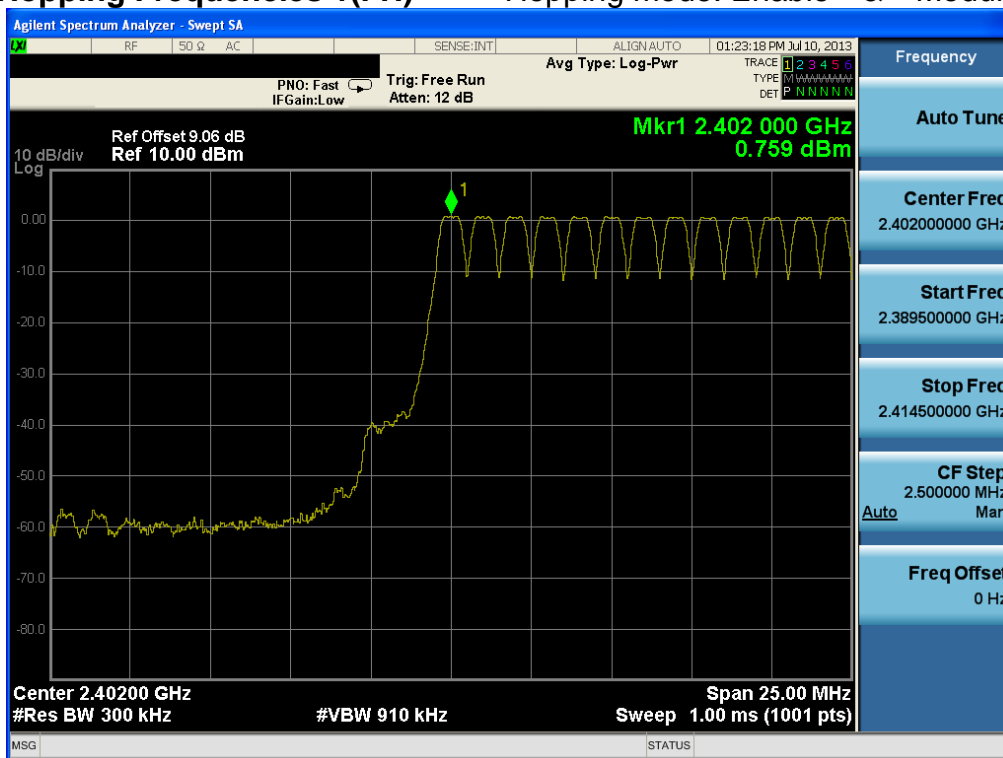

**Number of Hopping Frequencies 2(FH)** Hopping mode: Enable & Modulation: GFSK

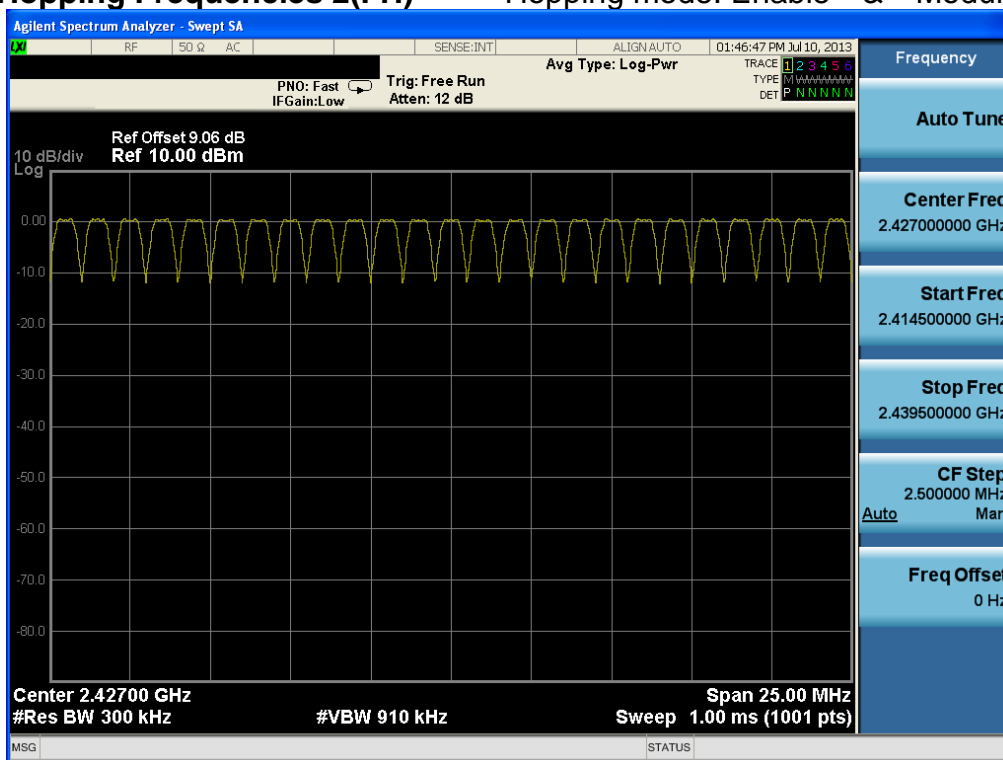

**Number of Hopping Frequencies 3(FH)** Hopping mode: Enable & Modulation: GFSK

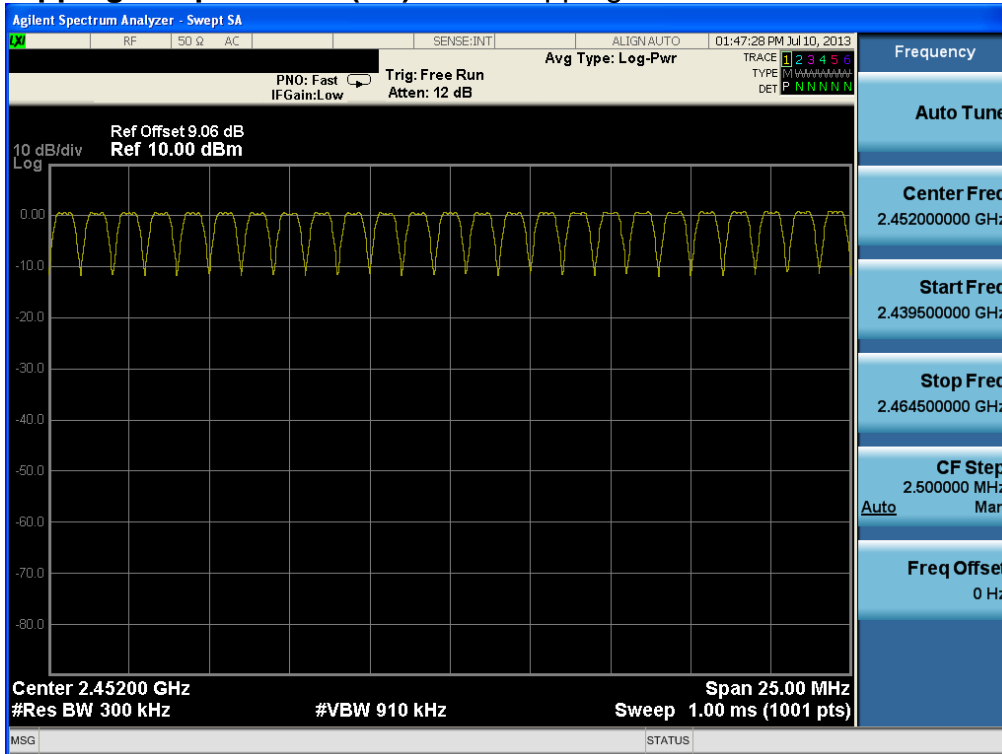

**Number of Hopping Frequencies 4(FH)** Hopping mode: Enable & Modulation: GFSK

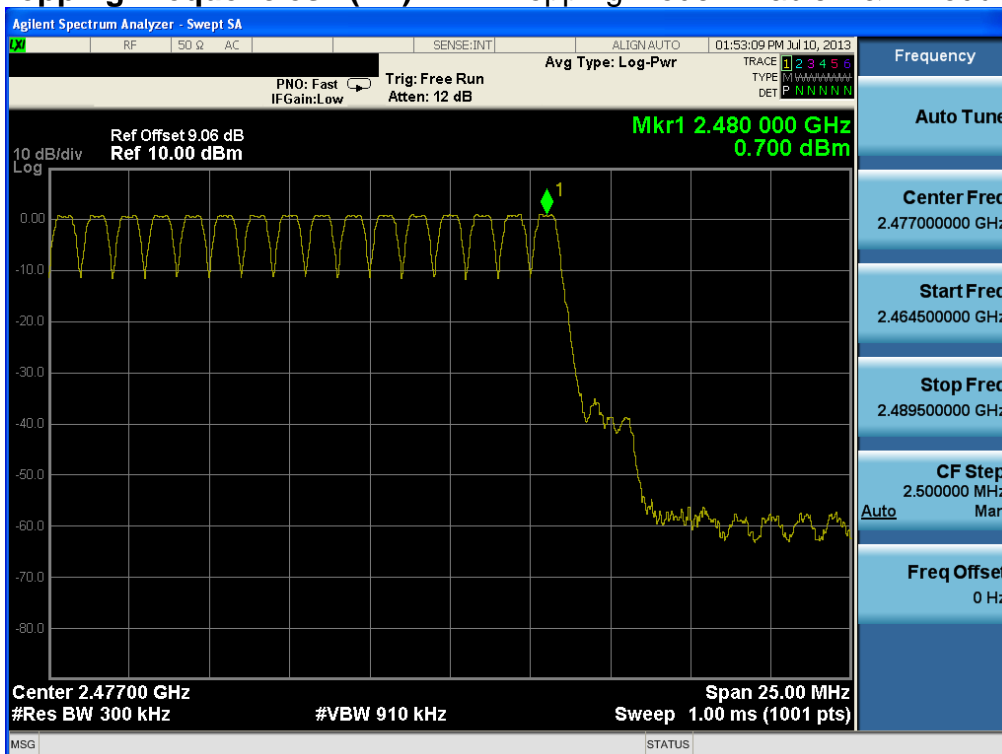



**Number of Hopping Frequencies 1(FH)** Hopping mode: Enable & Modulation:  $\pi/4$ DQPSK

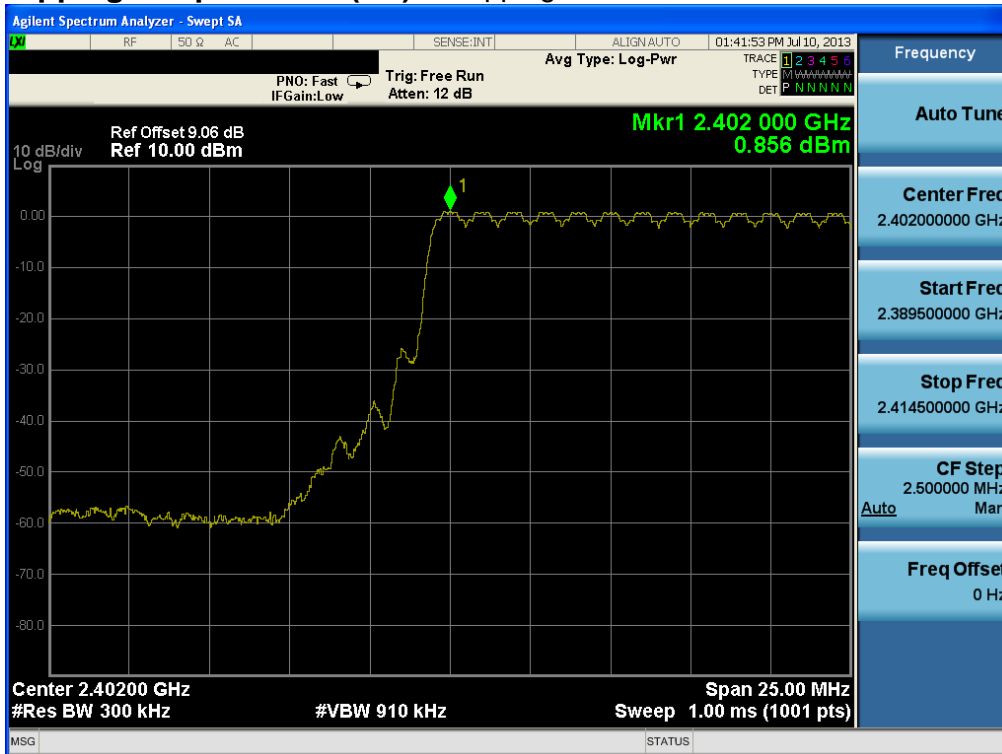

**Number of Hopping Frequencies 2(FH)** Hopping mode: Enable & Modulation:  $\pi/4$ DQPSK

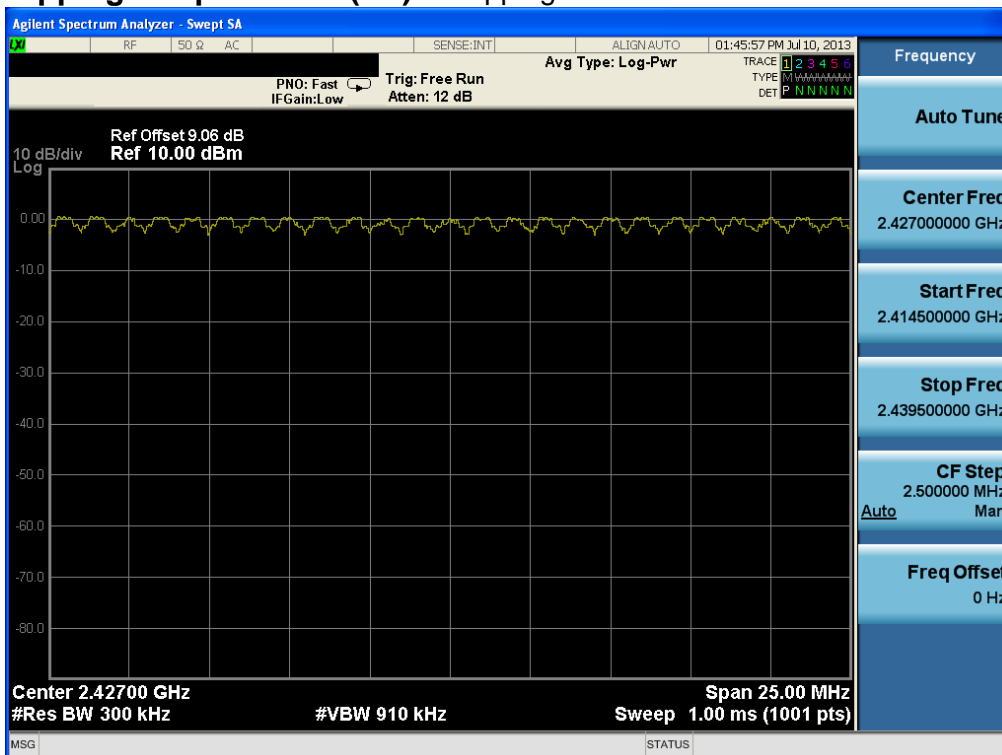

**Number of Hopping Frequencies 3(FH)** Hopping mode: Enable & Modulation:  $\pi/4$ DQPSK

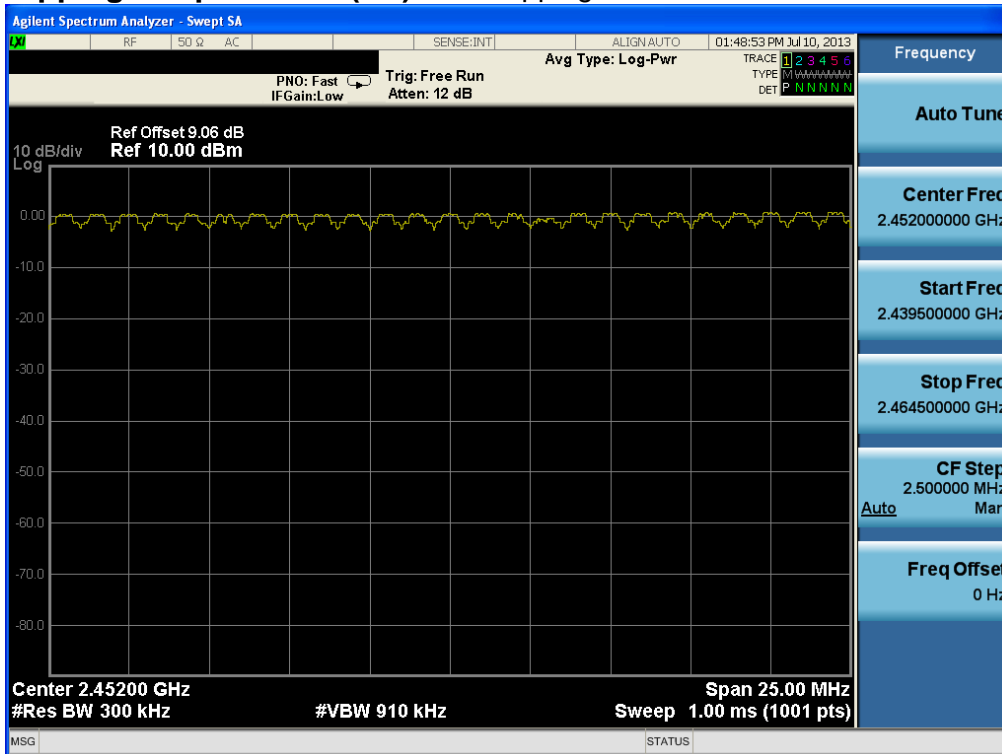

**Number of Hopping Frequencies 4(FH)** Hopping mode: Enable & Modulation:  $\pi/4$ DQPSK

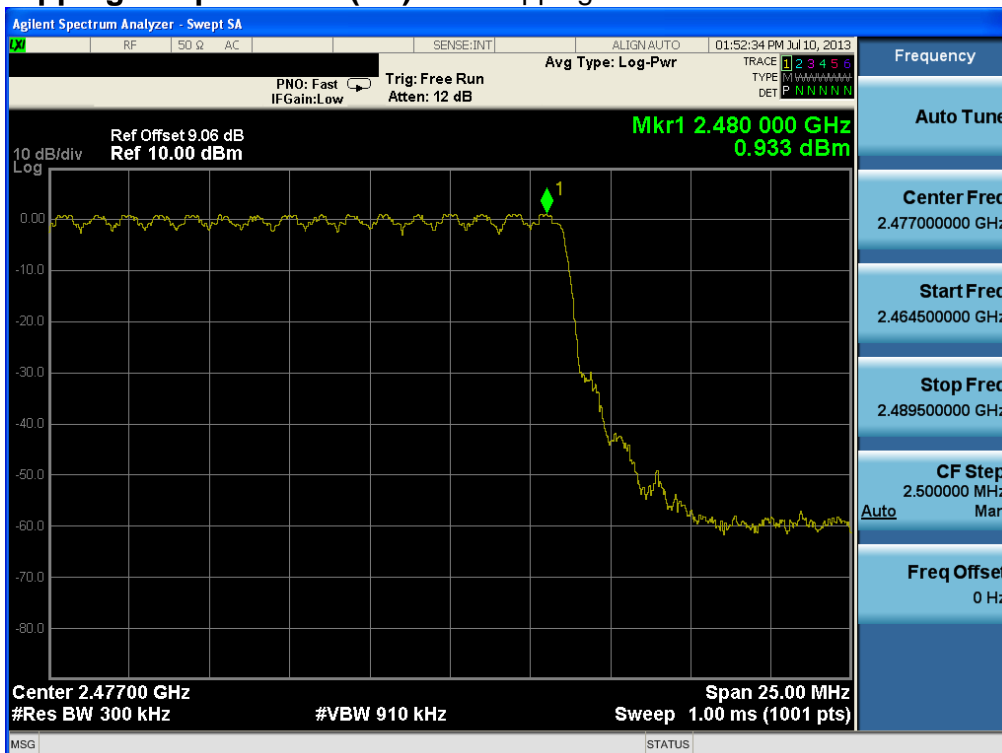

**Number of Hopping Frequencies 1(FH)** Hopping mode: Enable & Modulation: 8DPSK



**Number of Hopping Frequencies 2(FH)** Hopping mode: Enable & Modulation: 8DPSK

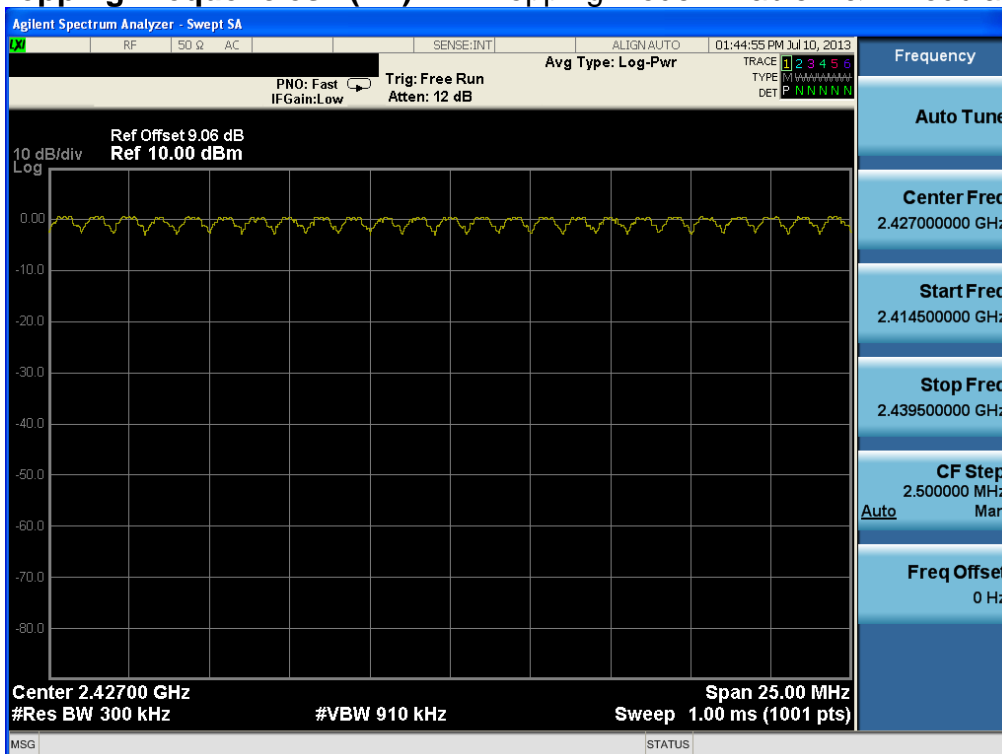

**Number of Hopping Frequencies 3(FH)      Hopping mode: Enable & Modulation: 8DPSK**

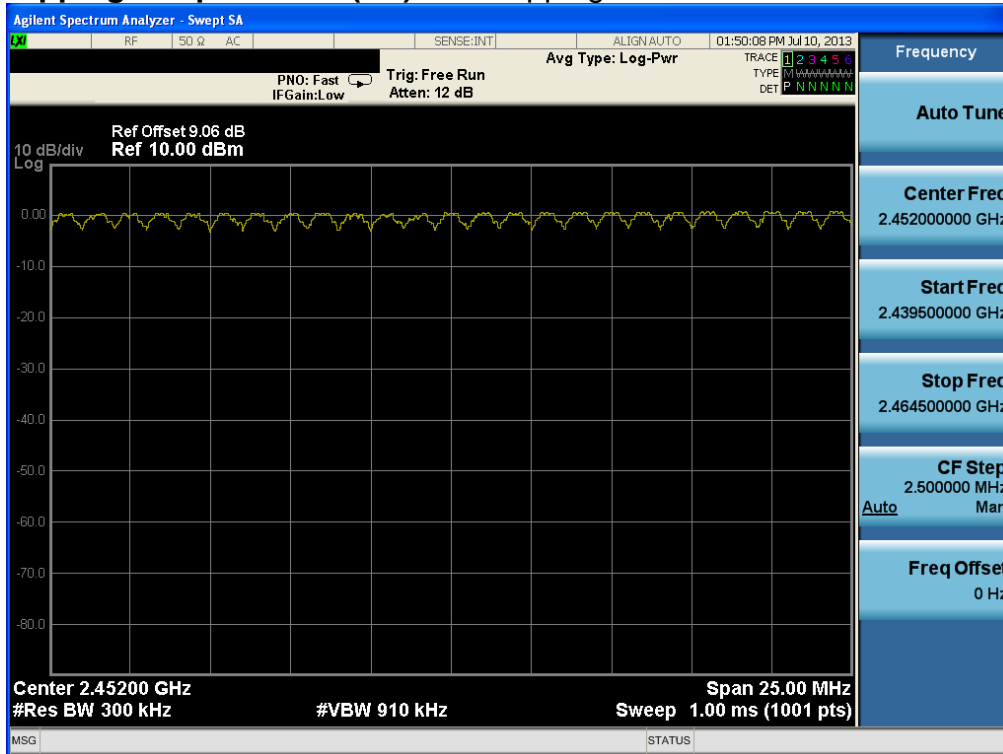

**Number of Hopping Frequencies 4(FH)      Hopping mode: Enable & Modulation: 8DPSK**

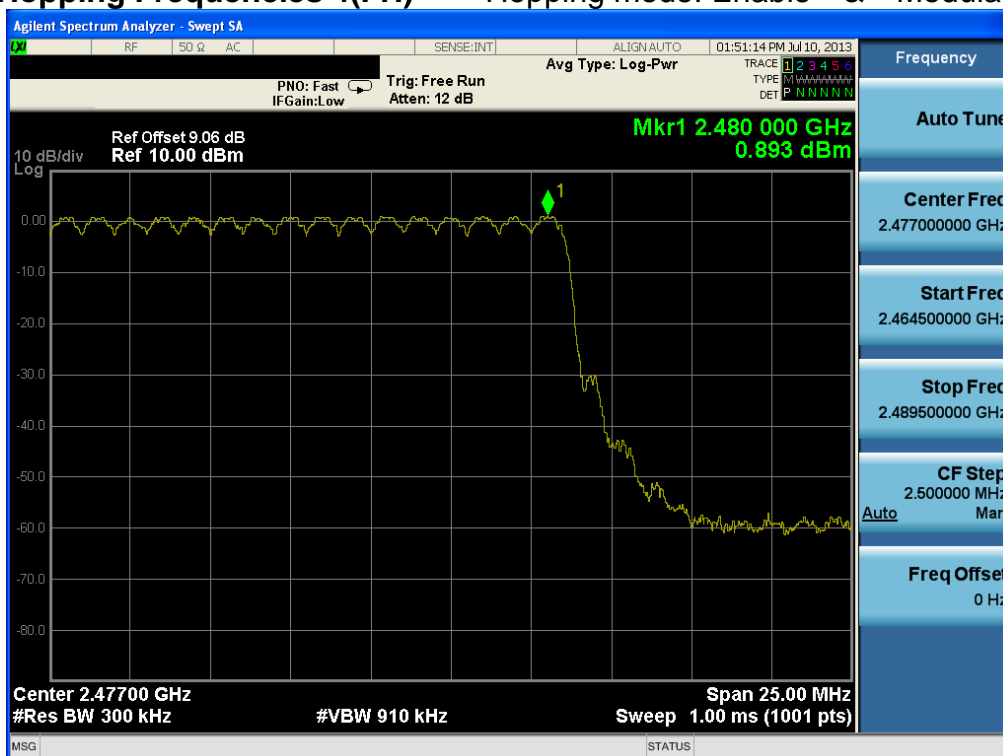

**Number of Hopping Frequencies 1(AFH) Hopping mode: Enable & Modulation: GFSK**

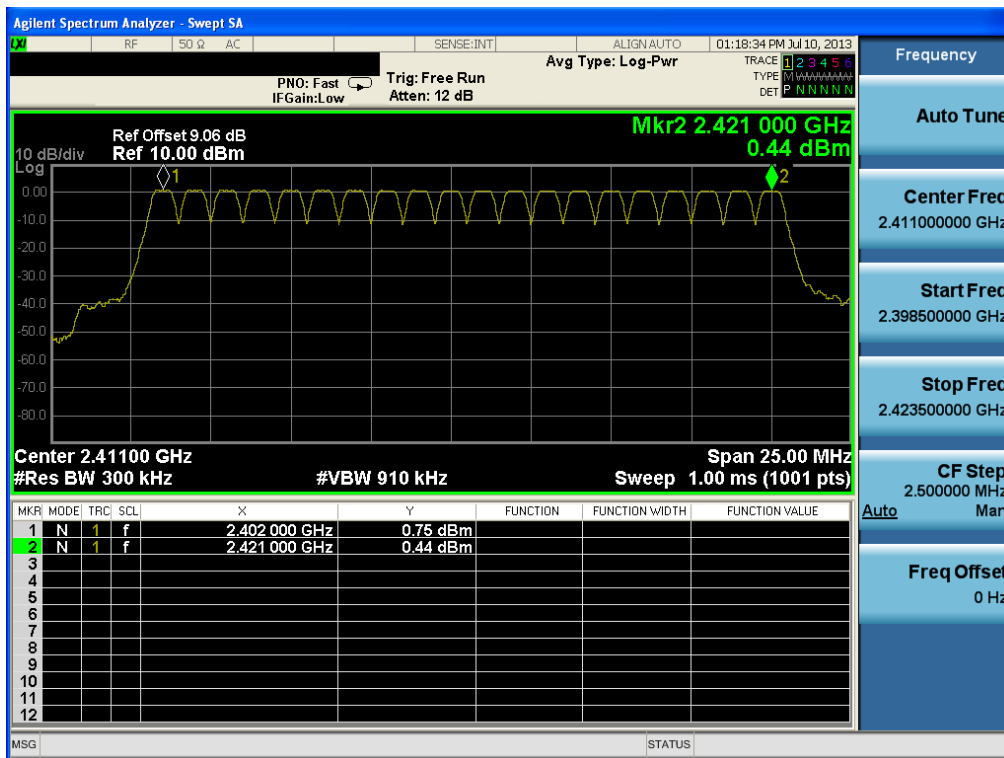

**Number of Hopping Frequencies 1(AFH) Hopping mode: Enable & Modulation:  $\pi/4$ DQPSK**

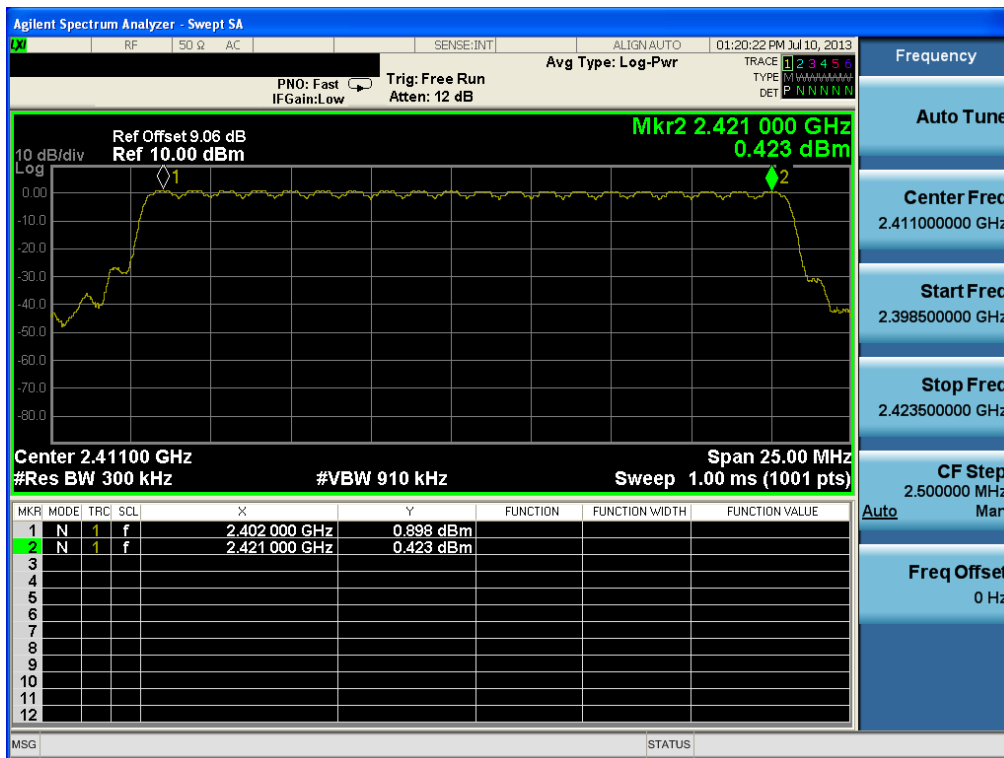

**Number of Hopping Frequencies 1(AFH) Hopping mode: Enable & Modulation: 8DPSK**

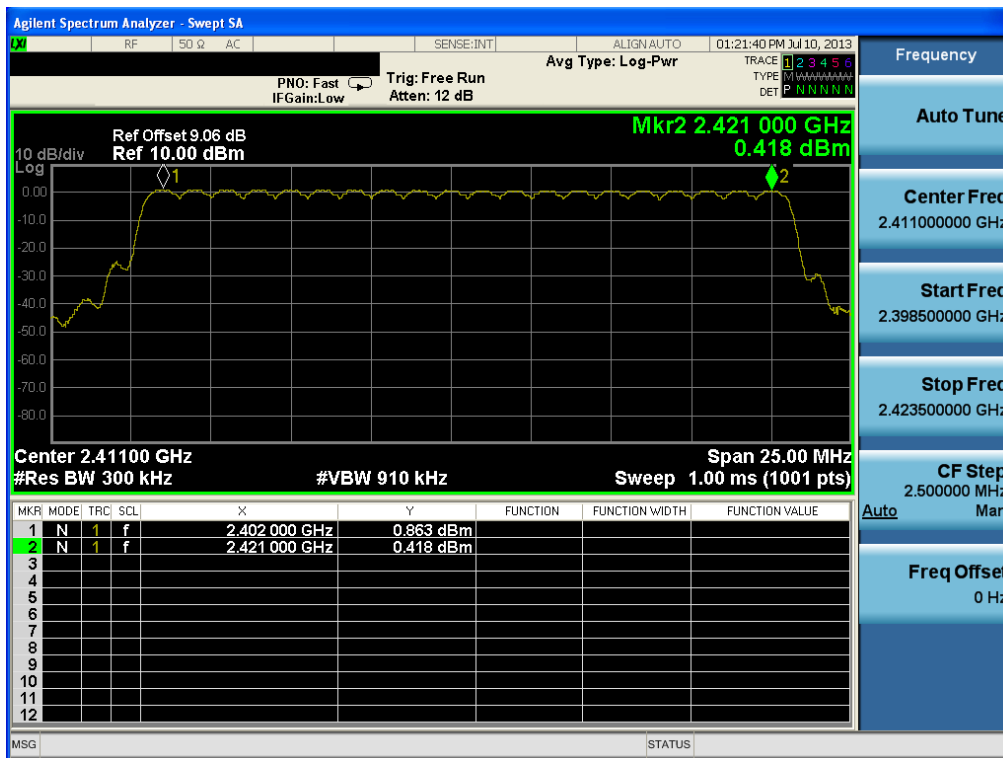

## 5. 20dBc BW

### 5.1. Test Setup

Refer to the APPENDIX I.

### 5.2. Limit

Limit: Not Applicable

### 5.3. Test Procedure

1. The 20dBc bandwidth were measured with a spectrum analyzer connected to RF antenna connector(conducted measurement) while EUT was operating in transmit mode. The analyzer center frequency was set to the EUT carrier frequency, using the analyzer.
2. The bandwidth of the fundamental frequency was measured with the spectrum analyzer using RBW  $\geq$  1% of the 20 dB bandwidth, VBW  $\geq$  RBW, Span = 3MHz.

### 5.4. Test Results

Ambient temperature : 24°C  
 Relative humidity : 56%

Modulation	Tested Channel	20dBc BW (MHz)
<b><u>GFSK</u></b>	Lowest	0.927
	Middle	0.930
	Highest	0.945
<b><u><math>\pi/4</math>DQPSK</u></b>	Lowest	1.308
	Middle	1.308
	Highest	1.308
<b><u>8DPSK</u></b>	Lowest	1.269
	Middle	1.257
	Highest	1.260

Note 1: See next pages for actual measured spectrum plots.

**20dBc Bandwidth**

**Lowest Channel & Modulation: GFSK**



**20dBc Bandwidth**

**Middle Channel & Modulation: GFSK**





**20dBc Bandwidth**

**Highest Channel & Modulation: GFSK**



**20dBc Bandwidth**

**Lowest Channel & Modulation:  $\pi/4$ DQPSK**



**20dBc Bandwidth**

**Middle Channel & Modulation:  $\pi/4$ QPSK**



**20dBc Bandwidth**

**Highest Channel & Modulation:  $\pi/4$ QPSK**



**20dBc Bandwidth**

**Lowest Channel & Modulation: 8DPSK**



**20dBc Bandwidth**

**Middle Channel & Modulation: 8DPSK**



**20dBc Bandwidth**

**Highest Channel & Modulation: 8DPSK**



## 6. Time of Occupancy (Dwell Time)

### 6.1. Test Setup

Refer to the APPENDIX I.

### 6.2. Limit

Limit: Not Applicable

### 6.3. Test Procedure

The dwell time was measured with a spectrum analyzer connected to the antenna terminal, while EUT had its hopping function enabled.

The spectrum analyzer is set to:

Center frequency = 2441 MHz

RBW = 1 MHz

Trace = max hold

Span = zero

VBW = ≥ RBW

Detector function = peak

### 6.4. Test Results

Ambient temperature : 24°C

Relative humidity : 53 %

#### - FH mode

Hopping mode	Packet Type	Number of hopping Channels	Burst On Time (ms)	Period (ms)	Test Result (sec)
Enable	DH 5	79	2.89	3.75	0.308
	2 DH 5	79	2.89	3.75	0.308
	3 DH 5	79	2.89	3.75	0.308

#### - AFH mode

Hopping mode	Packet Type	Number of hopping Channels	Burst On Time (ms)	Period (ms)	Test Result (sec)
Enable	DH 5	20	2.89	3.75	0.154
	2 DH 5	20	2.89	3.75	0.154
	3 DH 5	20	2.89	3.75	0.154

Note 1: Dwell Time =  $0.4 \times \text{Hopping channel} \times \text{Burst ON time} \times ((\text{Hopping rate} \div \text{Time slots}) \div \text{Hopping channel})$

- Time slots for DH5 = 6 slots(TX = 5 slot / RX = 1 slot)

- Hopping Rate = 1600 for FH mode & 800 for AFH mode

Note 2: See next pages for actual measured spectrum plots.

Time of Occupancy (FH)

Hopping mode: Enable & Modulation: GFSK

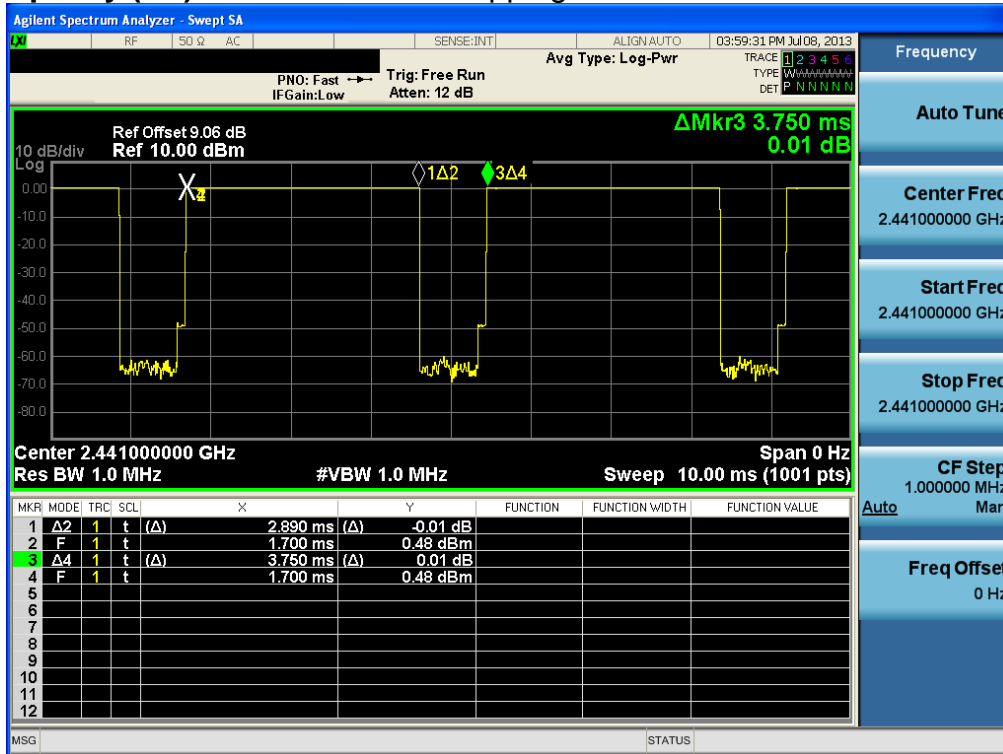

Time of Occupancy (FH)

Hopping mode: Enable & Modulation: π/4DQPSK

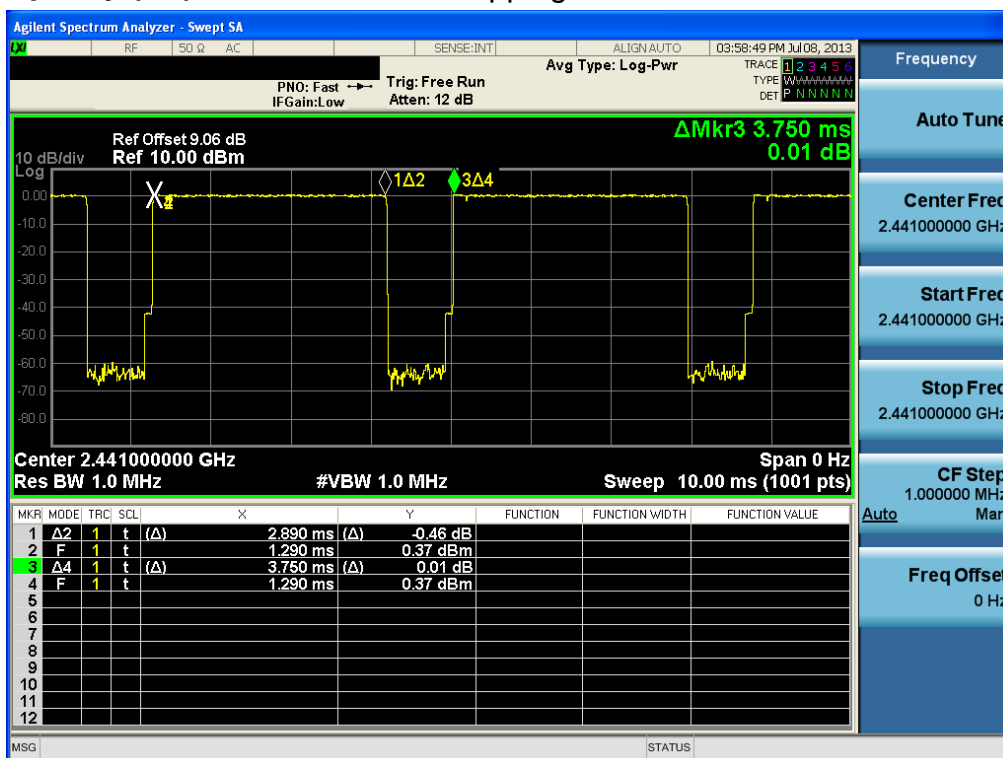

**Time of Occupancy (FH)**

Hopping mode: Enable & Modulation: 8DPSK

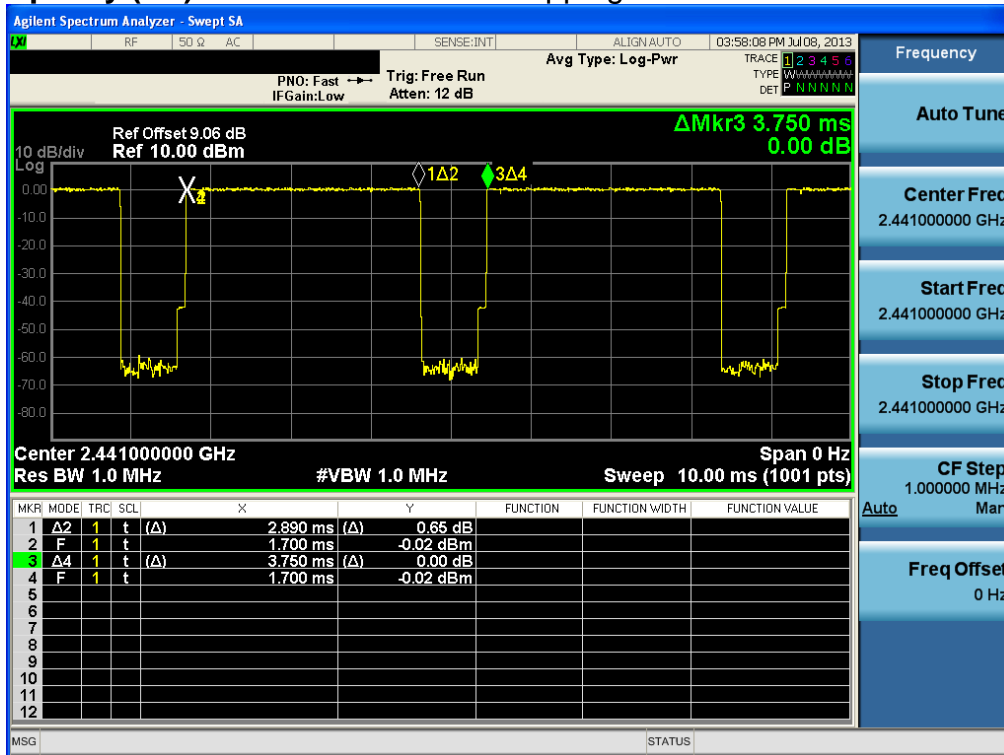

Time of Occupancy (AFH)

Hopping mode: Enable & Modulation: GFSK

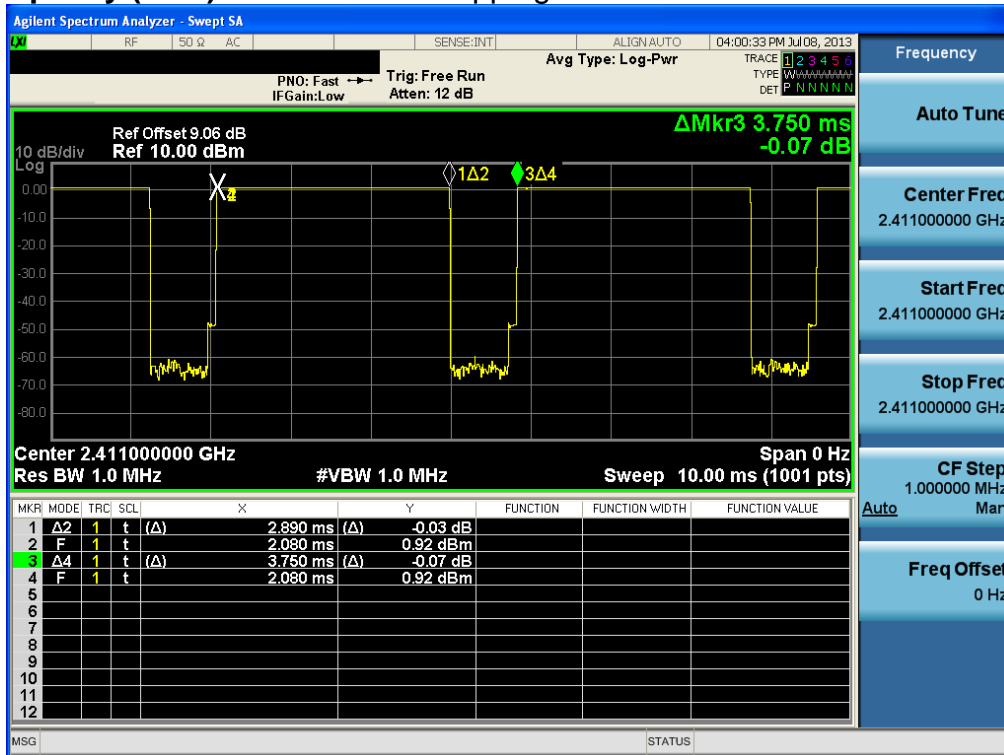

Time of Occupancy (AFH)

Hopping mode: Enable & Modulation:  $\pi/4$ DQPSK

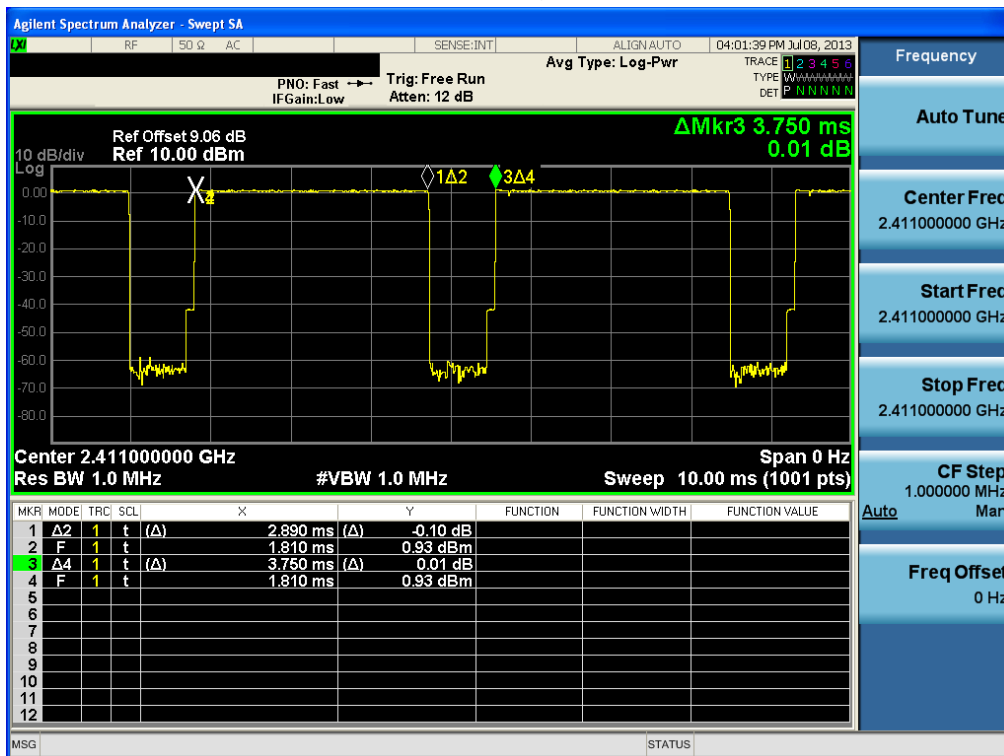



**Time of Occupancy (AFH)**

Hopping mode: Enable & Modulation: 8DPSK

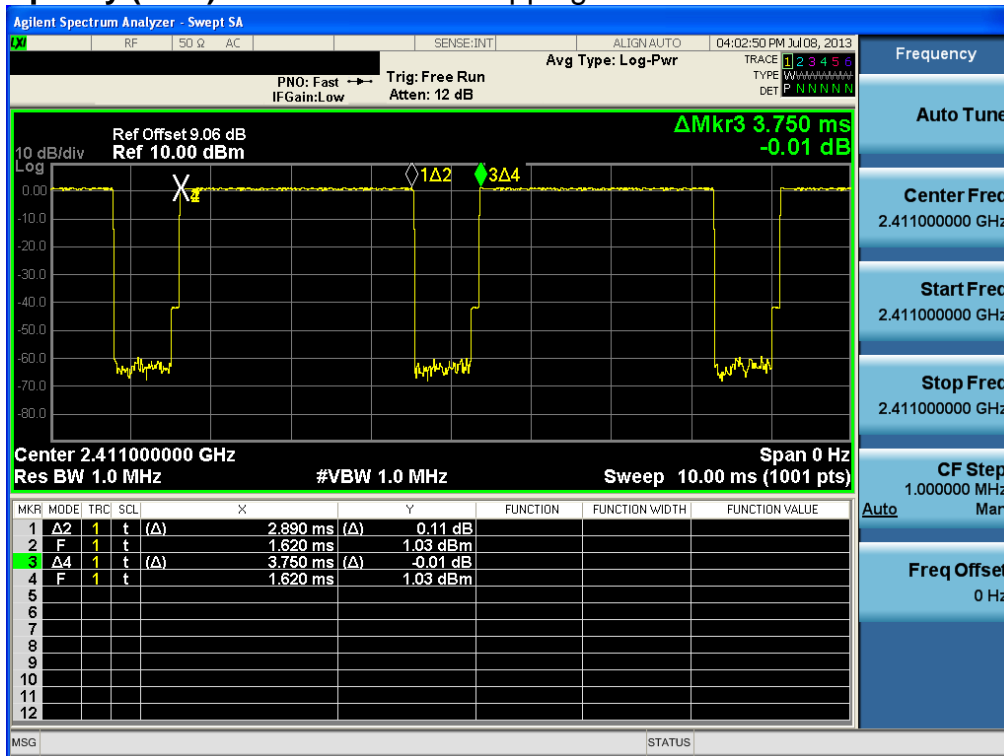

## 7. Maximum Peak Output Power Measurement

### 7.1. Test Setup

Refer to the APPENDIX I.

### 7.2. Limit

The maximum peak output power of the intentional radiator shall not exceed the following :

1. §15.247(a)(1), Frequency hopping systems shall have hopping channel carrier frequencies separated by a minimum of 25 kHz or the 20 dB bandwidth of the hopping channel, whichever is greater, provided the systems operate with an output power no greater than 125 mW.
2. §15.247(b)(1), For frequency hopping systems operating in the 2 400 – 2 483.5 MHz employing at least 75 non-overlapping hopping channels, and all frequency hopping systems in the 5 725 – 5 805 MHz band: 1 Watt.

### 7.3. Test Procedure

1. The RF power output was measured with a Spectrum analyzer connected to the RF Antenna connector (conducted measurement) while EUT was operating in transmit mode at the appropriate center frequency, A spectrum analyzer was used to record the shape of the transmit signal.
2. The bandwidth of the fundamental frequency was measured with the spectrum analyzer using ;  
Span = approximately 5 times the 20 dB bandwidth, centered on a hopping channel  
RBW ≥ 20dB BW  
VBW ≥ RBW  
Sweep = auto  
Detector function = peak  
Trace = max hold

### 7.4. Test Results

Ambient temperature : 24°C  
 Relative humidity : 53 %

Modulation	Tested Channel	Peak Output Power	
		dBm	mW
<b><u>GFSK</u></b>	Lowest	1.18	1.312
	Middle	0.65	1.161
	Highest	0.46	1.112
<b><u>1π/4DQPSK</u></b>	Lowest	1.70	1.479
	Middle	1.23	1.327
	Highest	1.14	1.300
<b><u>8DPSK</u></b>	Lowest	1.85	1.531
	Middle	1.42	1.387
	Highest	1.28	1.343

Note 1: See next pages for actual measured spectrum plots.

**Peak Output Power** Lowest Channel & Modulation: GFSK

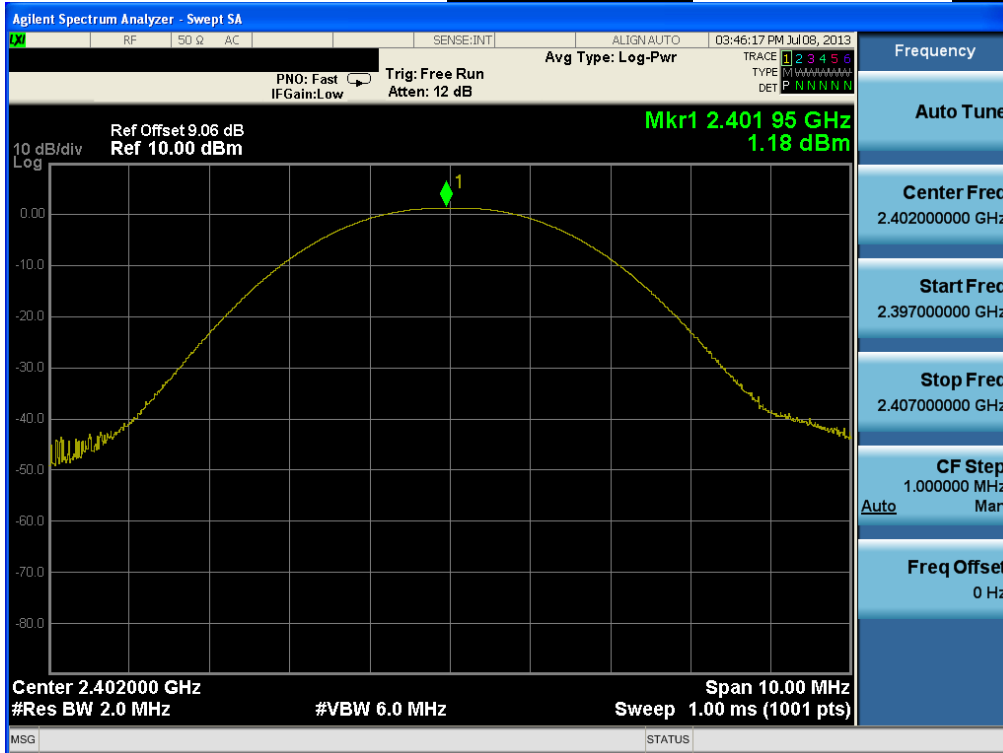

**Peak Output Power** Middle Channel & Modulation: GFSK

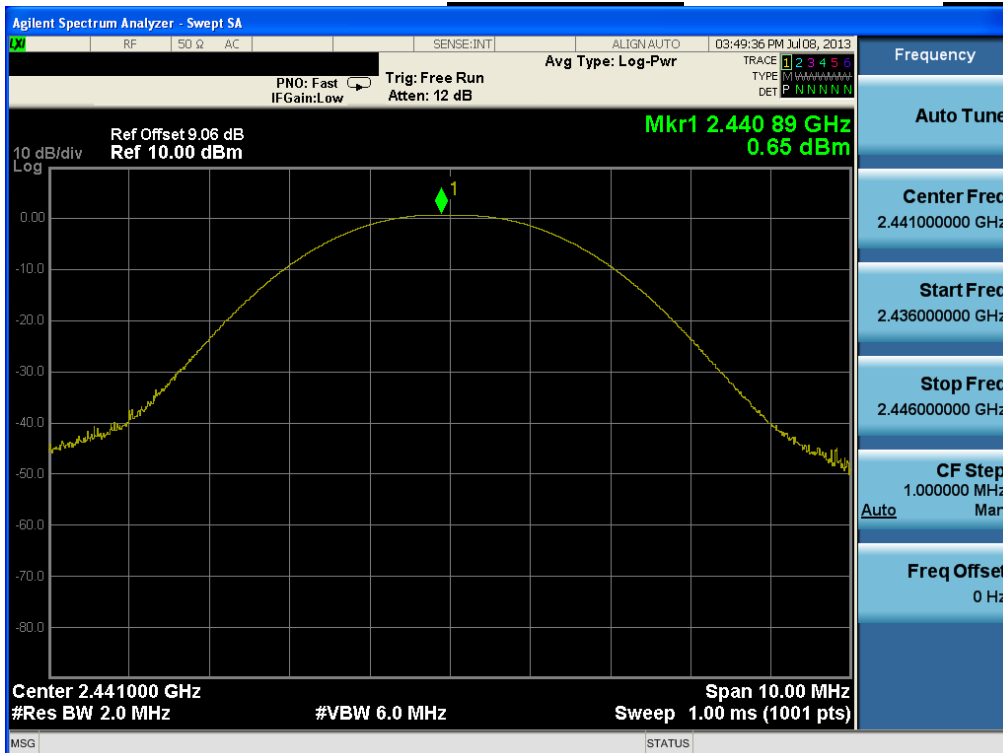

**Peak Output Power**

**Highest Channel & Modulation: GFSK**

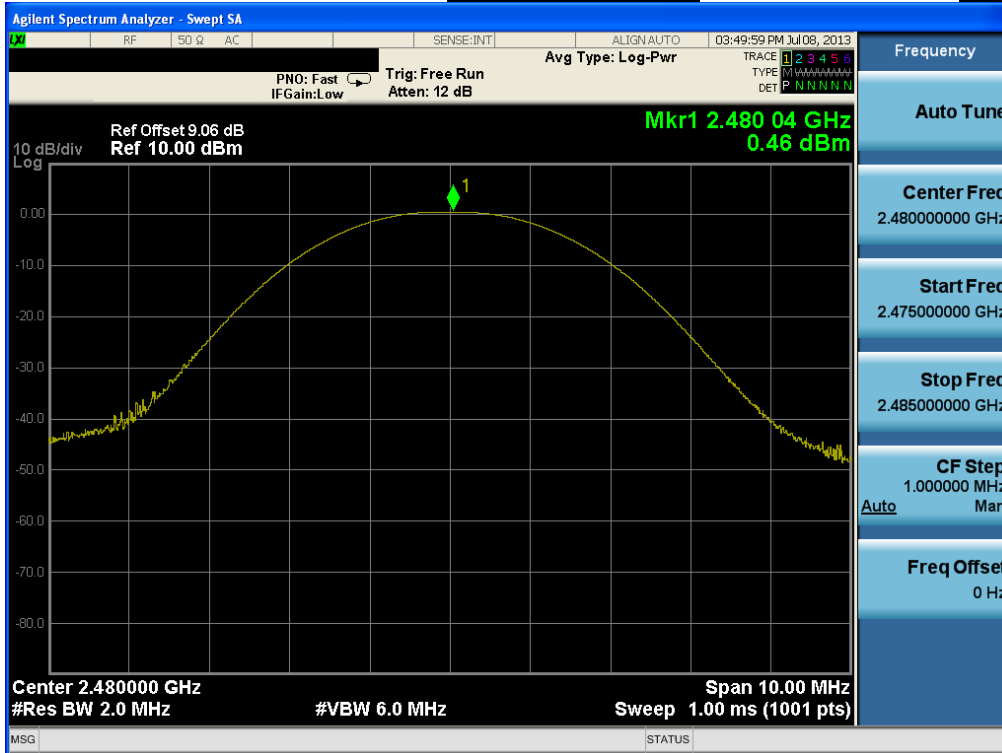

**Peak Output Power**

**Lowest Channel & Modulation:  $\pi/4$ DQPSK**

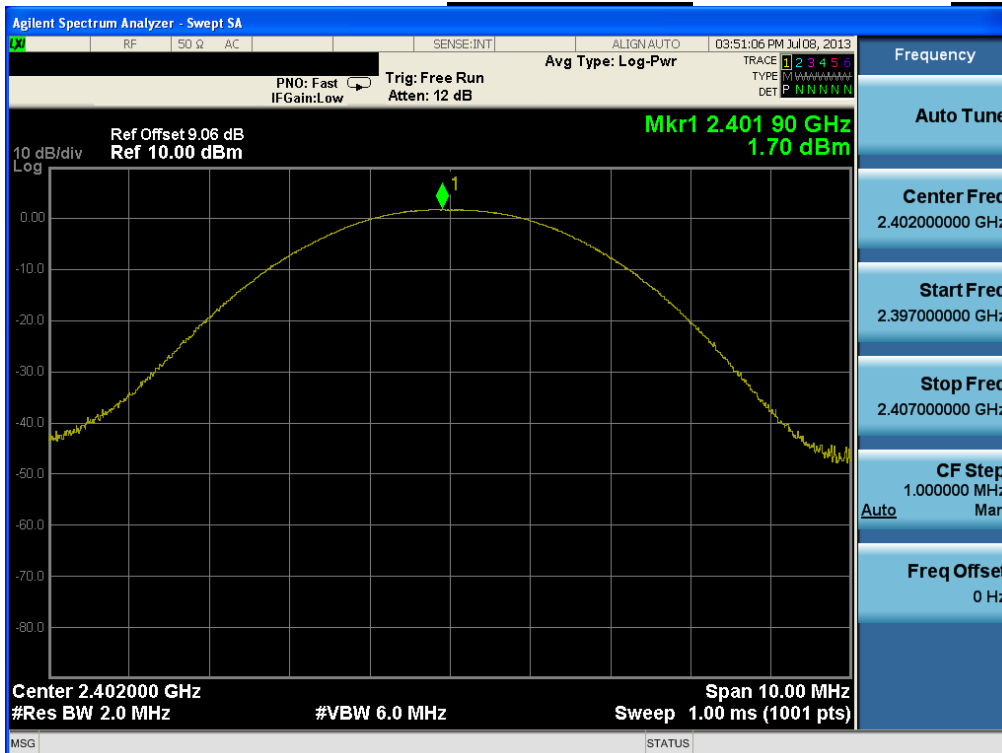

**Peak Output Power**

***Middle Channel*** & Modulation:  **$\pi/4$ QPSK**

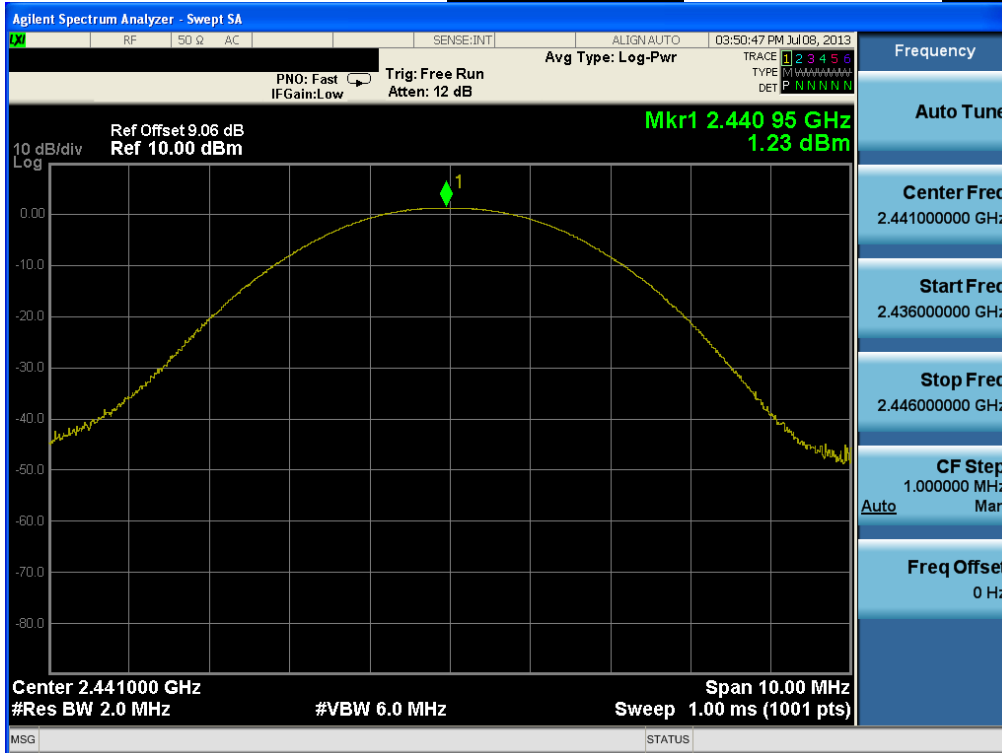

**Peak Output Power**

***Highest Channel*** & Modulation:  **$\pi/4$ QPSK**

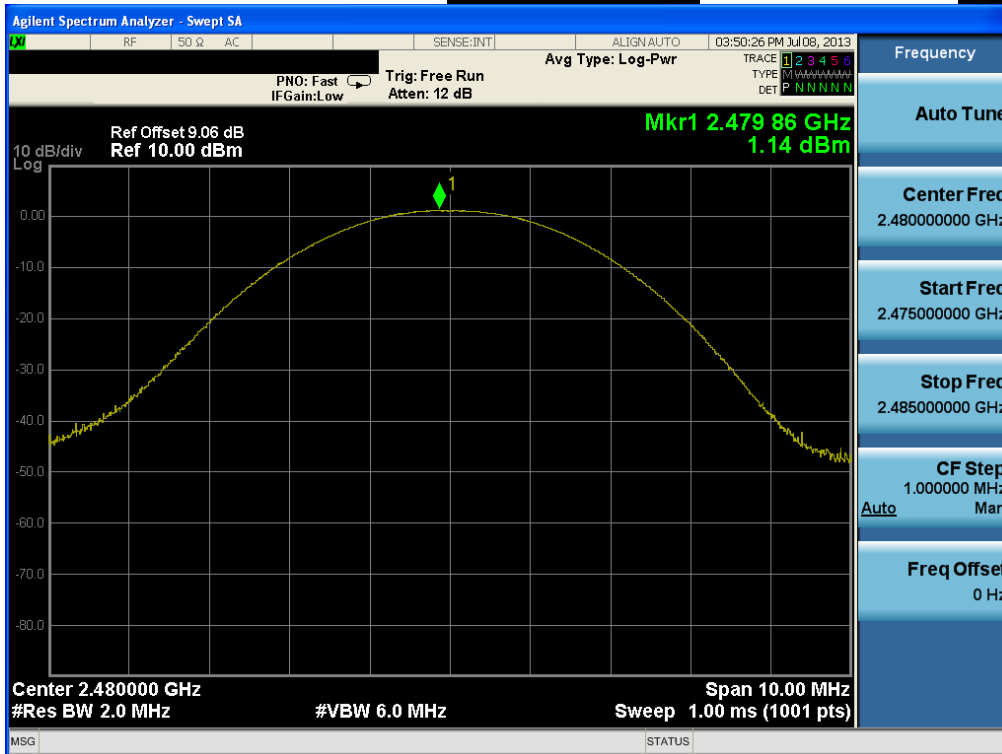

### Peak Output Power

### Lowest Channel & Modulation: 8DPSK

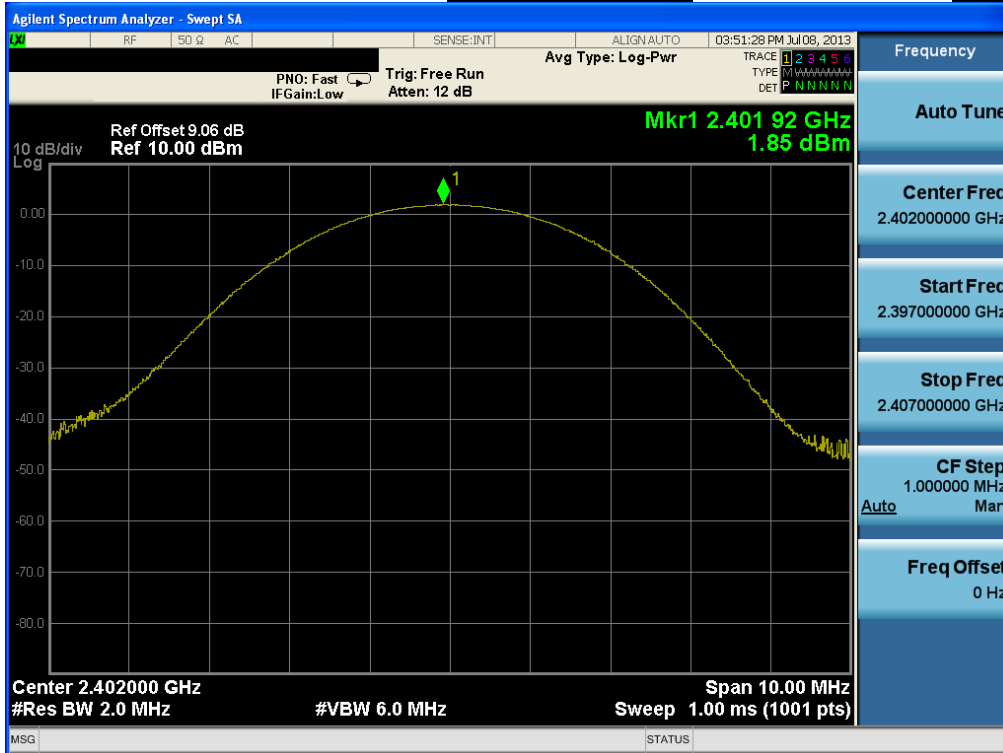

### Peak Output Power

### Middle Channel & Modulation: 8DPSK

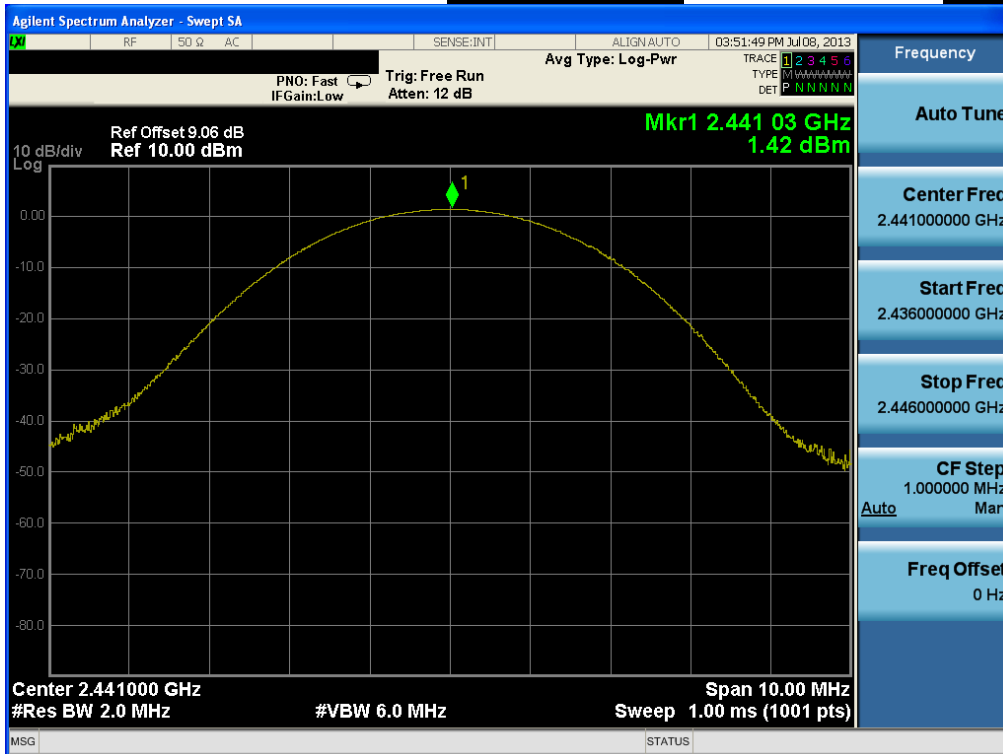

**Peak Output Power**

**Highest Channel & Modulation: 8DPSK**

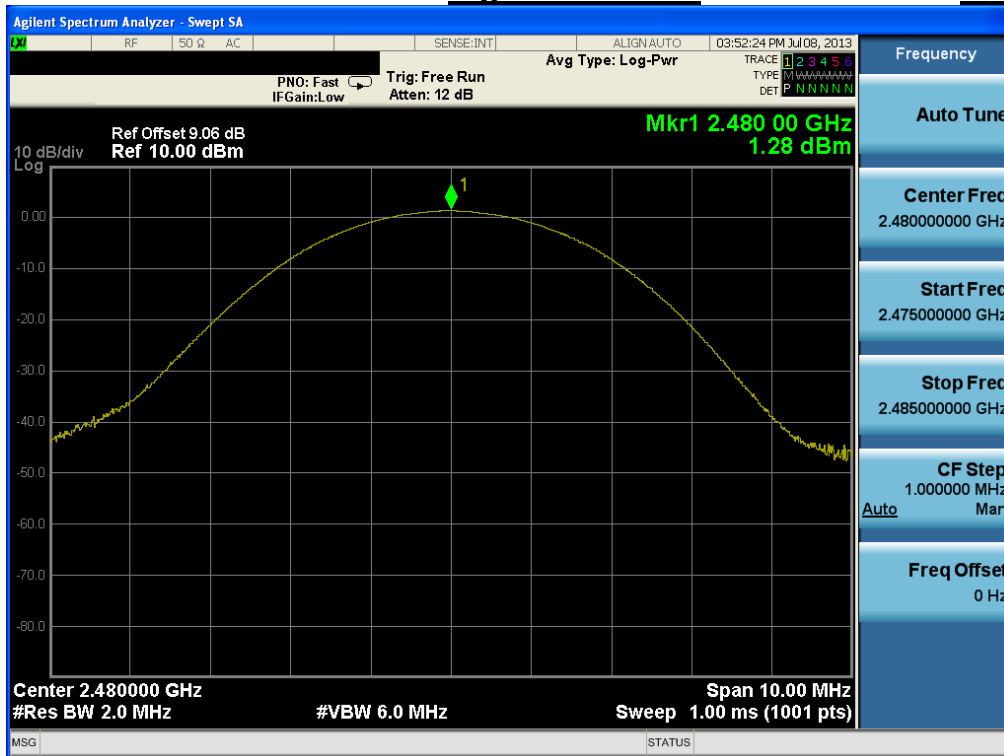



## 8. Transmitter AC Power Line Conducted Emission

### 8.1. Test Setup

**N/A**

### 8.2. Limit

According to §15.207(a) for an intentional radiator that is designed to be connected to the public utility (AC) power line, the radio frequency voltage that is conducted back onto the AC power line on any frequency or frequencies, within the band 150 kHz to 30 MHz, shall not exceed the limits in the following table, as measured using a 50 uH/50 ohm line impedance stabilization network(LISN).

Compliance with the provision of this paragraph shall on the measurement of the radio frequency voltage between each power line and ground at the power terminal. The lower applies at the boundary between the frequency ranges.

Frequency Range (MHz)	Conducted Limit (dBuV)	
	Quasi-Peak	Average
0.15 ~ 0.5	66 to 56 *	56 to 46 *
0.5 ~ 5	56	46
5 ~ 30	60	50

\* Decreases with the logarithm of the frequency

### 8.3. Test Procedures

Conducted emissions from the EUT were measured according to the dictates of ANSI C63.4-2009

1. The test procedure is performed in a 6.5 m × 3.5 m × 3.5 m (L × W × H) shielded room. The EUT along with its peripherals were placed on a 1.0 m (W) × 1.5 m (L) and 0.8 m in height wooden table and the EUT was adjusted to maintain a 0.4 meter space from a vertical reference plane.
2. The EUT was connected to power mains through a line impedance stabilization network (LISN) which provides 50 ohm coupling impedance for measuring instrument and the chassis ground was bounded to the horizontal ground plane of shielded room.
3. All peripherals were connected to the second LISN and the chassis ground also bounded to the horizontal ground plane of shielded room.
4. The excess power cable between the EUT and the LISN was bundled. The power cables of peripherals were unbundled. All connecting cables of EUT and peripherals were moved to find the maximum emission.

### 8.4. Test Results: **N/A**

This device is installed in a car. Therefore the power source is a battery of car.

## 9. Antenna Requirement

■ **Procedure:**

Describe how the EUT complies with the requirement that either its antenna is permanently attached, or that it employs a unique antenna connector, for every antenna proposed for use with the EUT.

■ **Conclusion: Comply**

\* The internal antenna of this E.U.T is permanently attached using the soldering.

\*Therefore this E.U.T Complies with the requirement of §15.203

■ **Minimum Standard:**

An intentional radiator shall be designed to ensure that no antenna other than that furnished by the responsible party shall be used with the device. The use of a permanently attached antenna or of an antenna that uses a unique coupling to the intentional radiator shall be considered sufficient to comply with the provisions.

## 10. Occupied Bandwidth(99%)

- **Procedure: (RSS-Gen Issue 3)**
- The 99% power bandwidth was measured with a calibrated spectrum analyzer.
- Spectrum analyzer plots are included on the following pages.

- **Measurement Data: Comply**

Test Mode	Tested Channel	Test Results (MHz)
<b><u>GFSK</u></b>	Lowest	0.873
	Middle	<b>0.881</b>
	Highest	0.877
<b><u><math>\pi/4</math>DQPSK</u></b>	Lowest	<b>1.202</b>
	Middle	1.196
	Highest	1.194
<b><u>8DPSK</u></b>	Lowest	<b>1.217</b>
	Middle	1.209
	Highest	1.211

Note 1: See next pages for actual measured spectrum plots.

- **Minimum Standard:**

N/A
-----

**Occupied Bandwidth (99%)**

**Lowest Channel** & Modulation: **GFSK**

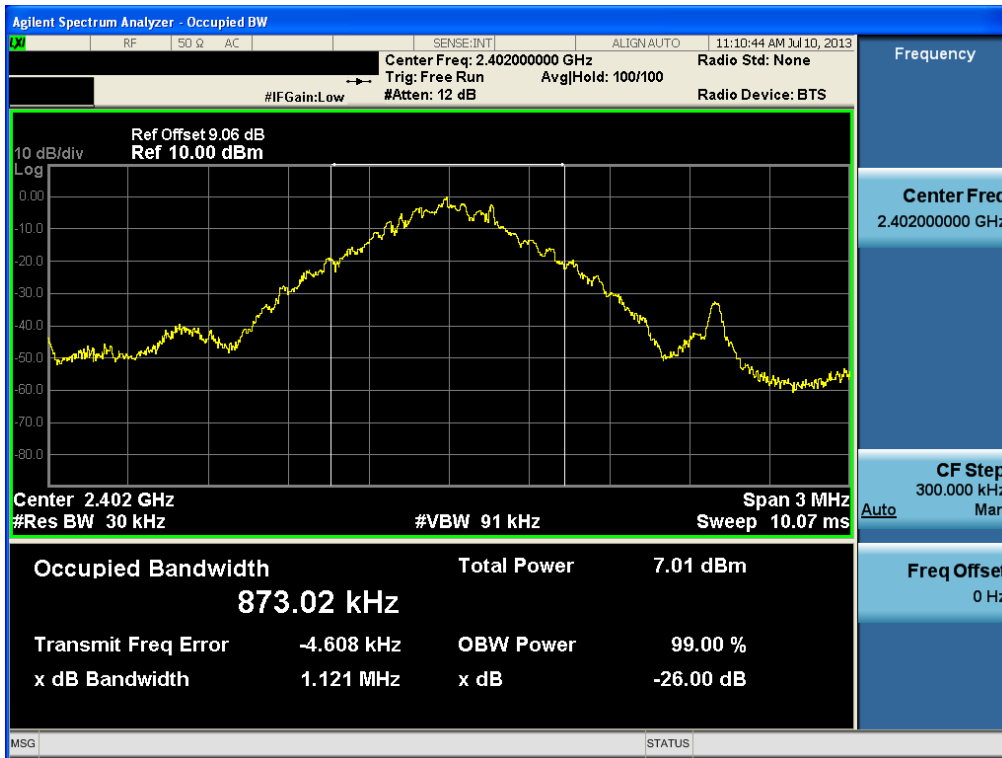

**Occupied Bandwidth (99%)**

**Middle Channel** & Modulation: **GFSK**

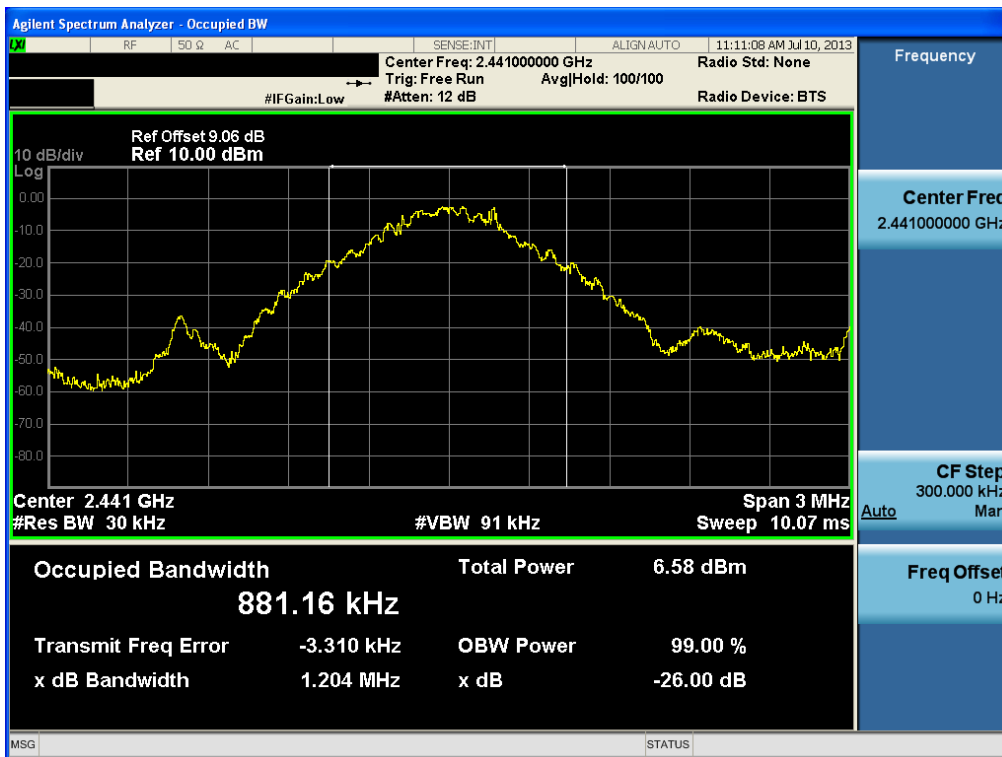

**Occupied Bandwidth (99%)**

***Highest Channel*** & Modulation: ***GFSK***

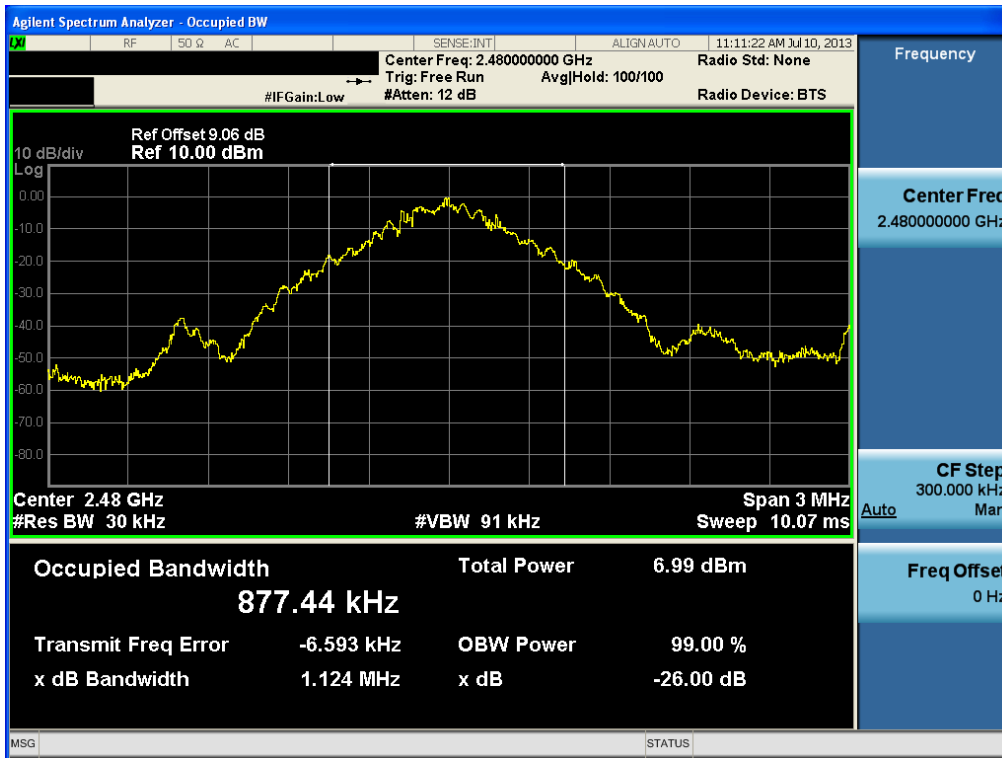

**Occupied Bandwidth (99%)**

**Lowest Channel** & Modulation:  **$\pi/4$ DQPSK**

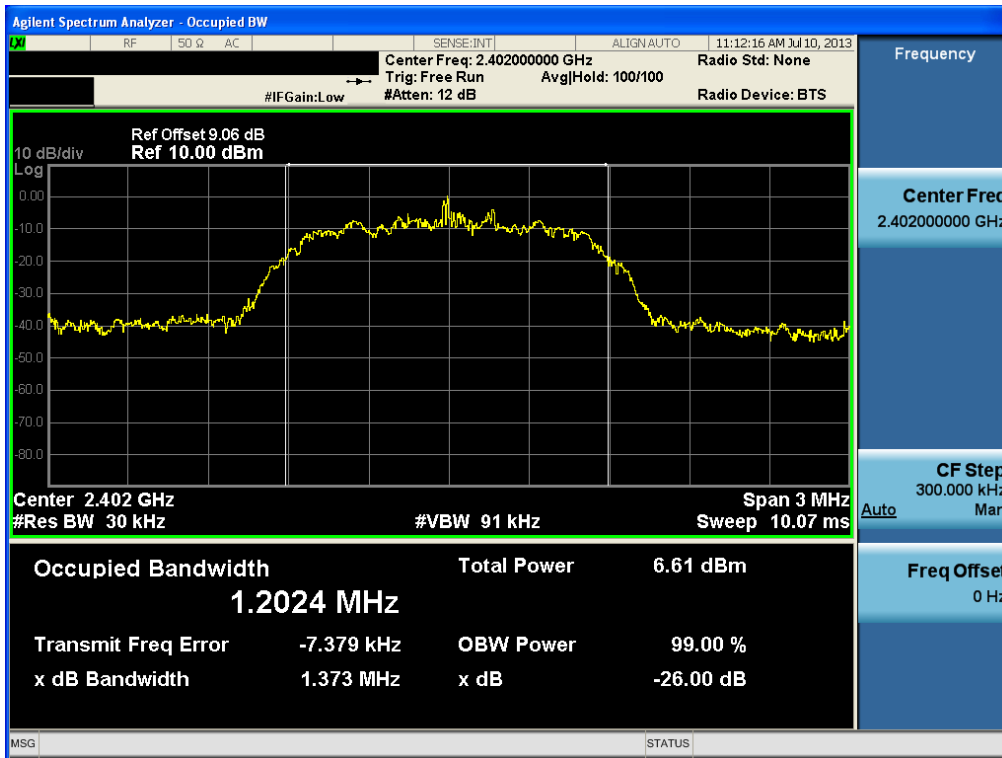

**Occupied Bandwidth (99%)**

**Middle Channel** & Modulation:  **$\pi/4$ DQPSK**

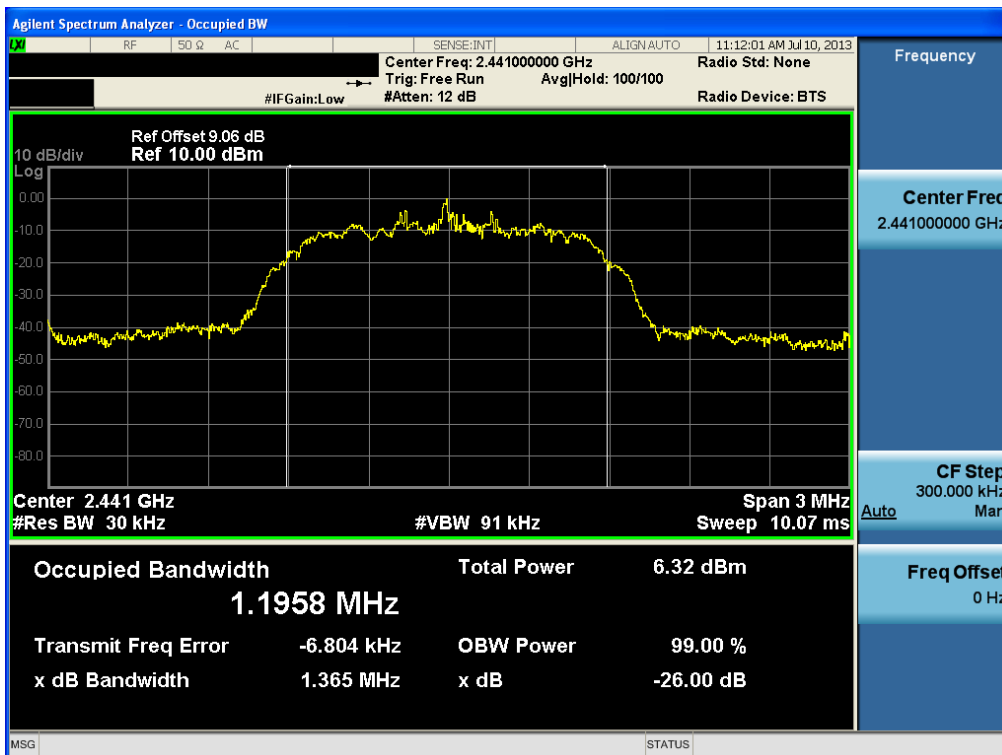

**Occupied Bandwidth (99%)**

***Highest Channel*** & Modulation:  **$\pi/4$ DQPSK**

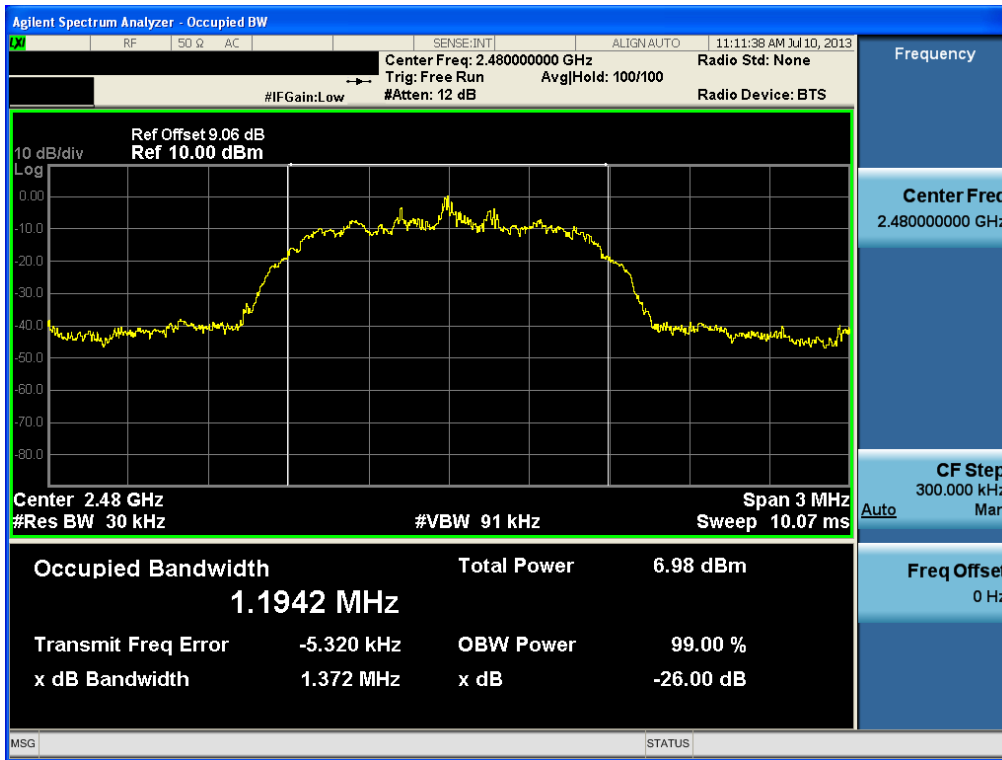

**Occupied Bandwidth (99%)**

**Lowest Channel** & Modulation: **8DPSK**

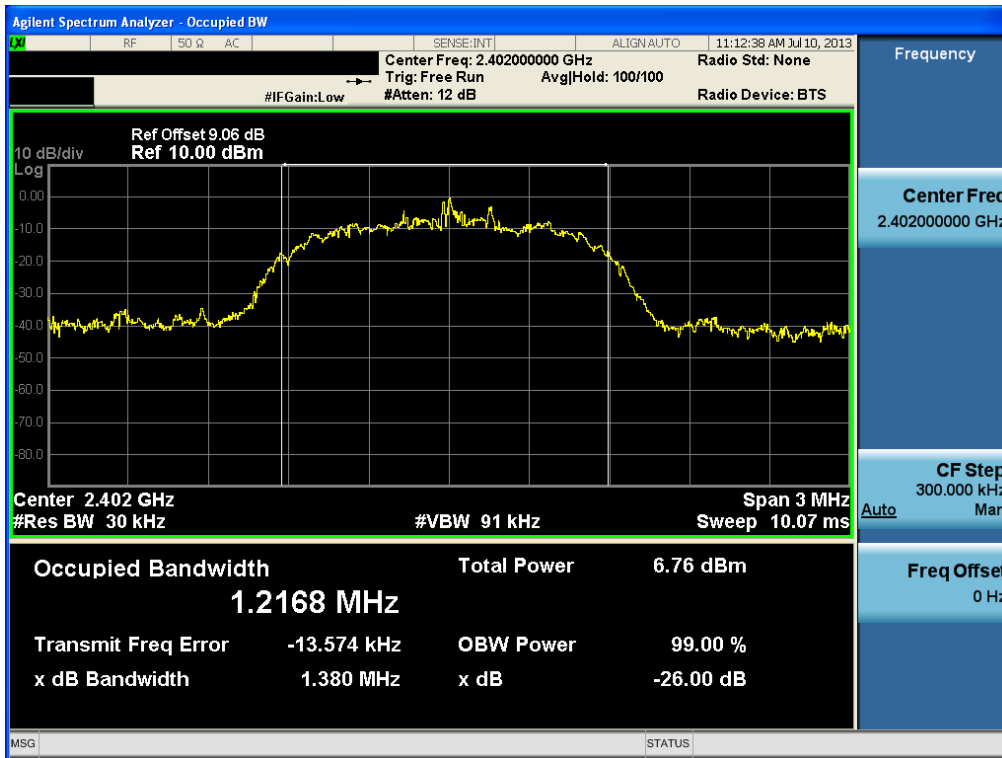

**Occupied Bandwidth (99%)**

**Middle Channel** & Modulation: **8DPSK**

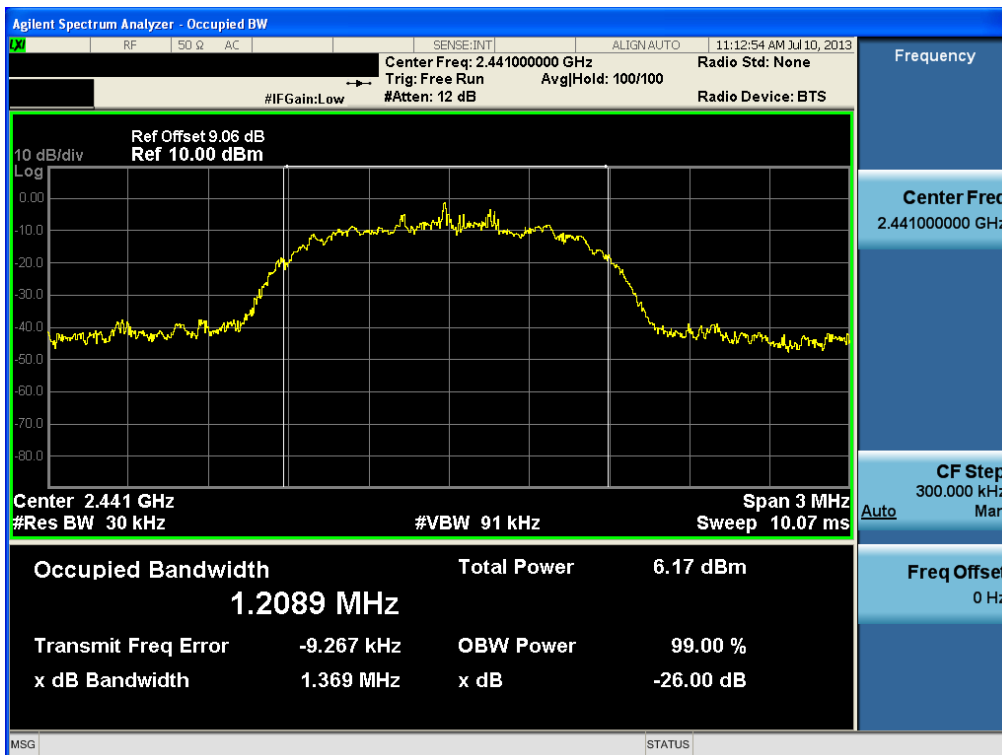



**Occupied Bandwidth (99%)**

***Highest Channel*** & Modulation: ***8DPSK***

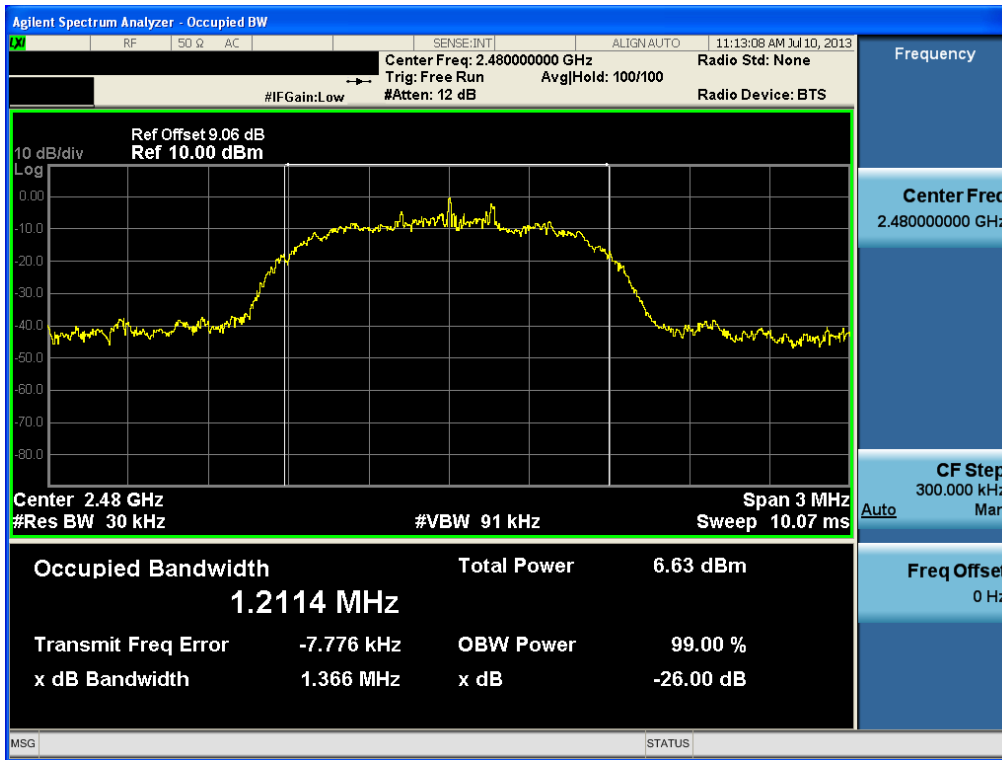

## APPENDIX I

### Test set up Diagrams & Path loss Information

#### ▪ Radiated Measurement

The diagram below shows the test setup that is utilized to make the measurements for emission from 30 MHz to 25 GHz Emissions.

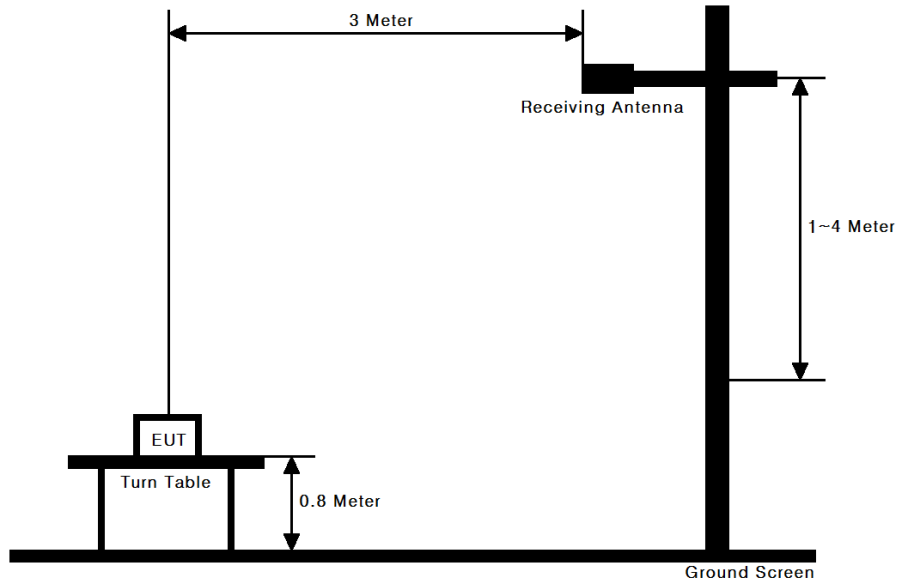

#### ▪ Conducted Measurement

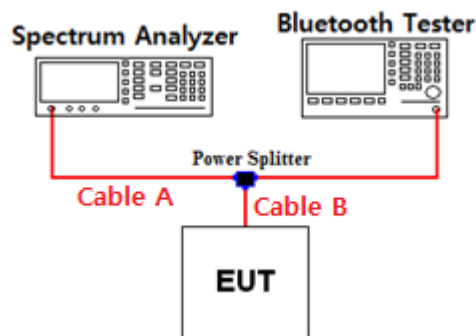

#### Offset value information

Frequency (GHz)	Path Loss (dB)	Frequency (GHz)	Path Loss (dB)
0.03	7.73	15	12.57
1	8.21	20	13.46
2.402 & 2.441 & 2.480	9.06	26.5	14.28
5	9.99	-	-
10	11.2	-	-

Note. 1: The path loss from EUT to Spectrum analyzer were measured and used for test.

Path loss ( = S/A's Offset value) = Cable A + Power Splitter + Cable B

Note. 2: For conducted spurious emissions, the offset values were saved as the transducer factors on the spurious measurement function of the spectrum analyzer and the transducer factor of tested frequency is calculated and corrected automatically by the spectrum analyzer's measurement function.