

## FCC Test Report (Co-Located)

**Report No.:** RF190618D07C

**FCC ID:** TK4WLE900VX (For WiFi)  
N7NEM7455 (For LTE)

**Test Model:** WLE900VX (For WiFi)  
EM7455 (For LTE)

**Received Date:** Mar. 18, 2020

**Test Date:** Mar. 26, 2020

**Issued Date:** Mar. 27, 2020

**Applicant:** Compex Systems Pte Ltd

**Address:** No 9 Harrison Road, Harrison Industrial Building, #05-01, 369651,  
Singapore

**Issued By:** Bureau Veritas Consumer Products Services (H.K.) Ltd., Taoyuan Branch  
Lin Kou Laboratories

**Lab Address:** No. 47-2, 14th Ling, Chia Pau Vil., Lin Kou Dist., New Taipei City, Taiwan

**FCC Registration /  
Designation Number:** 198487 / TW2021



This report is for your exclusive use. Any copying or replication of this report to or for any other person or entity, or use of our name or trademark, is permitted only with our prior written permission. This report sets forth our findings solely with respect to the test samples identified herein. The results set forth in this report are not indicative or representative of the quality or characteristics of the lot from which a test sample was taken or any similar or identical product unless specifically and expressly noted. Our report includes all of the tests requested by you and the results thereof based upon the information that you provided to us. You have 60 days from date of issuance of this report to notify us of any material error or omission caused by our negligence, provided, however, that such notice shall be in writing and shall specifically address the issue you wish to raise. A failure to raise such issue within the prescribed time shall constitute your unqualified acceptance of the completeness of this report, the tests conducted and the correctness of the report contents. Unless specific mention, the uncertainty of measurement has been explicitly taken into account to declare the compliance or non-compliance to the specification. The report must not be used by the client to claim product certification, approval, or endorsement by TAF or any government agencies.

## Table of Contents

<b>Release Control Record</b> .....	<b>3</b>
<b>1 Certificate of Conformity</b> .....	<b>4</b>
<b>2 Summary of Test Results</b> .....	<b>5</b>
2.1 Measurement Uncertainty .....	5
2.2 Modification Record .....	5
<b>3 General Information</b> .....	<b>6</b>
3.1 General Description of EUT .....	6
3.2 Test Mode Applicability and Tested Channel Detail .....	10
3.3 Description of Support Units .....	11
3.3.1 Configuration of System under Test .....	11
3.4 General Description of Applied Standard and references .....	12
<b>4 Test Types and Results</b> .....	<b>14</b>
4.1 Radiated Emission and Bandedge Measurement .....	14
4.1.1 Limits of Radiated Emission and Bandedge Measurement .....	14
4.1.2 Test Instruments .....	15
4.1.3 Test Procedure .....	16
4.1.4 Deviation from Test Standard .....	16
4.1.5 Test Setup .....	17
4.1.6 EUT Operating Condition .....	18
4.1.7 Test Results .....	19
<b>5 Pictures of Test Arrangements</b> .....	<b>21</b>
<b>Appendix – Information of the Testing Laboratories</b> .....	<b>22</b>

### Release Control Record

Issue No.	Description	Date Issued
RF190618D07C	Original release.	Mar. 27, 2020

## 1 Certificate of Conformity

**Product:** 802.11ac Dual Band Module (For WiFi)  
Wireless Modules (For LTE)

**Brand:** COMPEX (For WiFi)  
Sierra Wireless Inc. (For LTE)

**Test Model:** WLE900VX (For WiFi)  
EM7455 (For LTE)

**Sample Status:** Engineering sample

**Applicant:** Compex Systems Pte Ltd

**Test Date:** Mar. 26, 2020

**Standard:** 47 CFR FCC Part 15, Subpart C (Section 15.247)  
47 CFR FCC Part 15, Subpart E (Section 15.407)  
FCC Part 22, Subpart H  
FCC Part 24, Subpart E  
FCC Part 27, Subpart C, H, F, L, M, D  
FCC Part 90, Subpart I, S  
FCC Part 2  
ANSI C63.10: 2013

The above equipment has been tested by **Bureau Veritas Consumer Products Services (H.K.) Ltd., Taoyuan Branch**, and found compliance with the requirement of the above standards. The test record, data evaluation & Equipment Under Test (EUT) configurations represented herein are true and accurate accounts of the measurements of the sample's RF characteristics under the conditions specified in this report.

**Prepared by :** Annie Chang, **Date:** Mar. 27, 2020  
Annie Chang / Senior Specialist

**Approved by :** Rex Lai, **Date:** Mar. 27, 2020  
Rex Lai / Associate Technical Manager

## 2 Summary of Test Results

47 CFR FCC Part 15, Subpart C (Section 15.247), 47 CFR FCC Part 15, Subpart E (Section 15.407), 47 CFR FCC Part 22, 47 CFR FCC Part 24, 47 CFR FCC Part 27, FCC Part 90, Subpart I, S, 47 CFR FCC Part 2			
FCC Clause	Test Item	Result	Remarks
15.247(d) 15.407(b) (1/2/3/4(i/ii)/6) 2.1053 22.917 24.238 27.53(h) 27.53(g) 27.53(c)(2)&(f) 27.53(m)(4)(6) 27.53(a)(4) 90.691	Radiated Emissions Measurement	Pass	Meet the requirement of limit. Minimum passing margin is -4.59dB at 5350.00MHz.

Note: Determining compliance based on the results of the compliance measurement, not taking into account measurement instrumentation uncertainty.

### 2.1 Measurement Uncertainty

Where relevant, the following measurement uncertainty levels have been estimated for tests performed on the EUT as specified in CISPR 16-4-2:

Measurement	Frequency	Expanded Uncertainty (k=2) ( $\pm$ )
Radiated Emissions above 1 GHz	Above 1GHz	5.14 dB

### 2.2 Modification Record

There were no modifications required for compliance.

### 3 General Information

#### 3.1 General Description of EUT

##### WiFi Module (FCC ID: TK4WLE900VX)

Product	802.11ac Dual Band Module
Brand	COMPEX
Test Model	WLE900VX
Status of EUT	Engineering sample
Modulation Type	CCK, DQPSK, DBPSK for DSSS 64QAM, 16QAM, QPSK, BPSK for OFDM 256QAM for OFDM in 11ac mode only.
Modulation Technology	DSSS, OFDM
Transfer Rate	802.11b: up to 11Mbps 802.11g: up to 54Mbps 802.11a: up to 54Mbps 802.11n: up to 450Mbps 802.11ac: up to 1299.9Mbps
Operating Frequency	2412 ~ 2462MHz, 5180 ~ 5240MHz, 5745 ~ 5825MHz
Number of Channel	<b>2412~2462MHz</b> 11 for 802.11b, 802.11g, 802.11n (20MHz) 7 for 802.11n (40MHz) <b>5180~5240MHz</b> 4 for 802.11a, 802.11n (20MHz), 802.11ac (20MHz) 2 for 802.11n (40MHz), 802.11ac (40MHz) 1 for 802.11ac (80MHz) <b>5745~5825MHz</b> 5 for 802.11a, 802.11n (20MHz) 802.11ac (20MHz) 2 for 802.11n (40MHz) 802.11ac (40MHz) 1 for 802.11ac (80MHz)
Output Power	<b>2412~2462MHz:</b> 209.152mW <b>5180~5240MHz:</b> 139.657mW <b>5745~5825MHz:</b> 254.153mW
Antenna Type	Refer to note as below
Antenna Connector	Reverse SMA
Accessory Device	N/A
Data Cable Supplied	N/A

**LTE Module (FCC ID: N7NEM7455)**

Product	Wireless Modules	
Brand	Sierra Wireless Inc.	
Test Model	EM7455	
Status of EUT	MASS-PRODUCTION	
Power Supply Rating	3.3 Vdc (Host equipment)	
Modulation Type	WCDMA	QPSK
	LTE	QPSK, 16QAM
Frequency Range <WCDMA>	WCDMA	826.4 ~ 846.6 MHz, 1852.4 ~ 1907.6 MHz, 1712.4 ~ 1752.6 MHz
Frequency Range <LTE Band 4>	LTE Band 4 (Channel Bandwidth: 1.4 MHz)	1710.7 ~ 1754.3 MHz
	LTE Band 4 (Channel Bandwidth: 3 MHz)	1711.5 ~ 1753.5 MHz
	LTE Band 4 (Channel Bandwidth: 5 MHz)	1712.5 ~ 1752.5 MHz
	LTE Band 4 (Channel Bandwidth: 10 MHz)	1715.0 ~ 1750.0 MHz
	LTE Band 4 (Channel Bandwidth: 15 MHz)	1717.5 ~ 1747.5 MHz
	LTE Band 4 (Channel Bandwidth: 20 MHz)	1720.0 ~ 1745.0 MHz
Frequency Range <LTE Band 5>	LTE Band 5 (Channel Bandwidth: 1.4 MHz)	824.7 ~ 848.3 MHz
	LTE Band 5 (Channel Bandwidth: 3 MHz)	825.5 ~ 847.5 MHz
	LTE Band 5 (Channel Bandwidth: 5 MHz)	826.5 ~ 846.5 MHz
	LTE Band 5 (Channel Bandwidth: 10 MHz)	829 ~ 844 MHz
Frequency Range <LTE Band 7>	LTE Band 7 (Channel Bandwidth: 5 MHz)	2502.5 ~ 2567.5 MHz
	LTE Band 7 (Channel Bandwidth: 10 MHz)	2505 ~ 2565 MHz
	LTE Band 7 (Channel Bandwidth: 15 MHz)	2507.5 ~ 2562.5 MHz
	LTE Band 7 (Channel Bandwidth: 20 MHz)	2510 ~ 2560 MHz
Frequency Range <LTE Band 12>	LTE Band 12 (Channel Bandwidth: 1.4 MHz)	699.7 ~ 715.3 MHz
	LTE Band 12 (Channel Bandwidth: 3 MHz)	700.5 ~ 714.5 MHz
	LTE Band 12 (Channel Bandwidth: 5 MHz)	701.5 ~ 713.5 MHz
	LTE Band 12 (Channel Bandwidth: 10 MHz)	704.0 ~ 711.0 MHz
Frequency Range <LTE Band 13>	LTE Band 13 (Channel Bandwidth: 5 MHz)	779.5 ~ 784.5 MHz
	LTE Band 13 (Channel Bandwidth: 10 MHz)	782.0 MHz
Frequency Range <LTE Band 25>	LTE Band 25 (Channel Bandwidth: 1.4 MHz)	1850.7 ~ 1914.3 MHz
	LTE Band 25 (Channel Bandwidth: 3 MHz)	1851.5 ~ 1913.5 MHz
	LTE Band 25 (Channel Bandwidth: 5 MHz)	1852.5 ~ 1912.5 MHz
	LTE Band 25 (Channel Bandwidth: 10 MHz)	1855.0 ~ 1910.0 MHz
	LTE Band 25 (Channel Bandwidth: 15 MHz)	1857.5 ~ 1907.5 MHz
	LTE Band 25 (Channel Bandwidth: 20 MHz)	1860.0 ~ 1905.0 MHz
Frequency Range <LTE Band 26_Part 22>	LTE Band 26 (Channel Bandwidth: 1.4 MHz)	824.7 ~ 848.3 MHz
	LTE Band 26 (Channel Bandwidth: 3 MHz)	825.5 ~ 847.5 MHz
	LTE Band 26 (Channel Bandwidth: 5 MHz)	826.5 ~ 846.5 MHz
	LTE Band 26 (Channel Bandwidth: 10 MHz)	829 ~ 844 MHz
	LTE Band 26 (Channel Bandwidth: 15 MHz)	831.5 ~ 841.5 MHz

Frequency Range <LTE Band 26_Part 90S>	LTE Band 26 (Channel Bandwidth: 1.4 MHz)	814.7 ~ 823.3 MHz
	LTE Band 26 (Channel Bandwidth: 3 MHz)	815.5 ~ 822.5 MHz
	LTE Band 26 (Channel Bandwidth: 5 MHz)	816.5 ~ 821.5 MHz
	LTE Band 26 (Channel Bandwidth: 10 MHz)	819 MHz
Frequency Range <LTE Band 30>	LTE Band 30 (Channel Bandwidth: 5 MHz)	2307.5 ~ 2312.5 MHz
	LTE Band 30 (Channel Bandwidth: 10 MHz)	2310 MHz
Frequency Range <LTE Band 41>	LTE Band 41 (Channel Bandwidth: 5 MHz)	2498.5 ~ 2687.5 MHz
	LTE Band 41 (Channel Bandwidth: 10 MHz)	2501.0 ~ 2685.0 MHz
	LTE Band 41 (Channel Bandwidth: 15 MHz)	2503.5 ~ 2682.5 MHz
	LTE Band 41 (Channel Bandwidth: 20 MHz)	2506.0 ~ 2680.0 MHz
Antenna Type	LTE Band 5 & 26	Dipole Antenna with 3.2 dBi gain
	LTE Band 25	Dipole Antenna with 1.56 dBi gain
	LTE Band 4	Dipole Antenna with 1.62 dBi gain
	LTE Band 12	Dipole Antenna with 1.49 dBi gain
	LTE Band 13	Dipole Antenna with 1.66 dBi gain
	LTE Band 7 & 41	Dipole Antenna with 0.86 dBi gain
	LTE Band 30	Dipole Antenna with 2.27 dBi gain
	WCDMA_ 826.4 ~ 846.6 MHz	Dipole Antenna with 3.2 dBi gain
	WCDMA_ 1852.4 ~ 1907.6 MHz	Dipole Antenna with 1.56 dBi gain
WCDMA_ 1712.4 ~ 1752.6 MHz	Dipole Antenna with 1.62 dBi gain	
Accessory Device	N/A	
Data Cable Supplied	N/A	

Note:

1. The EUT provides 3 completed transmitter and 3 receiver.

Modulation Mode	TX Function
802.11a	1TX
802.11b	1TX
802.11g	1TX
802.11n (20MHz)	3TX
802.11n (40MHz)	3TX
802.11ac (20MHz)	3TX
802.11ac (40MHz)	3TX
802.11ac (80MHz)	3TX

2. This report is prepared for FCC class II permissive change.
3. 2.4GHz and 5GHz modes cannot transmit simultaneously.
4. WiFi & LTE technologies can transmit at same time.
5. The emission of the simultaneous operation has been evaluated and no non-compliance was found.



6. The antenna information is listed as below:

Description	Platform: Network Security Appliance (Brand: Check Point / Model: V-81WLR)
Antenna Model	RFDPA171300SBLB801
Antenna Type	Dipole Antenna
Maximum Gain (dBi)	2412-2462MHz: 2.22 5180-5825MHz: 4.29

The Platform is authorized for use frequency bands: 2412-2462MHz, 5180-5240MHz and 5745-5825MHz only.

7. Accessory device of Platform as follows.

Brand	Model	Rating
FSP	FSP120-AHAN3	AC I/P : 100-240V ~ 2.0A 50-60Hz DC O/P: 12.0V ===10.0A 120.0W Power cord: Non-shielded AC 3 Pin (1.8m) Non-shielded DC cable (1.45m) with one ferrite core

8. The above EUT information is declared by manufacturer and for more detailed features description, please refer to the manufacturer's specifications or user's manual.

### 3.2 Test Mode Applicability and Tested Channel Detail

EUT Configure Mode	Applicable To	Description
	RE $\geq$ 1G	
-	√	-

Where **RE $\geq$ 1G**: Radiated Emission above 1GHz

**NOTE:** The EUT had been pre-tested on the positioned of each 3 axis. The worst case was found when positioned on **X-plane**.

#### **Radiated Emission Test (Above 1GHz):**

- Pre-Scan has been conducted to determine the worst-case mode from all possible combinations between available modulations, data rates and antenna ports (if EUT with antenna diversity architecture).
- Following channel(s) was (were) selected for the final test as listed below.

EUT Configure Mode	Mode
-	WCDMA B5_QPSK: CH4182 + WiFi 5GHz_802.11ac (20MHz) : CH 48
-	LTE B12_QPSK: CH23130 (Bandwidth: 10MHz) + WiFi 5GHz_802.11ac (20MHz) : CH 48

#### **Test Condition:**

Applicable To	Environmental Conditions	Input Power	Tested By
RE $\geq$ 1G	22deg. C, 75%RH	120Vac, 60Hz	Ian Chang

### 3.3 Description of Support Units

The EUT has been tested as an independent unit together with other necessary accessories or support units. The following support units or accessories were used to form a representative test configuration during the tests.

ID	Product	Brand	Model No.	Serial No.	FCC ID	Remarks
A.	GPS Antenna	GNS	N/A	N/A	N/A	Supplied by client

Note: All power cords of the above support units are non-shielded (1.8m).

ID	Cable Descriptions	Qty.	Length (m)	Shielding (Yes/No)	Cores (Qty.)	Remarks
1.	DC cable	1	1.45	N	1	Supplied by client
2.	AC power cord	1	1.8	N	0	Supplied by client
3.	Coaxial cable	1	3.0	Y	0	Supplied by client

Note: The core(s) is(are) originally attached to the cable(s).

#### 3.3.1 Configuration of System under Test

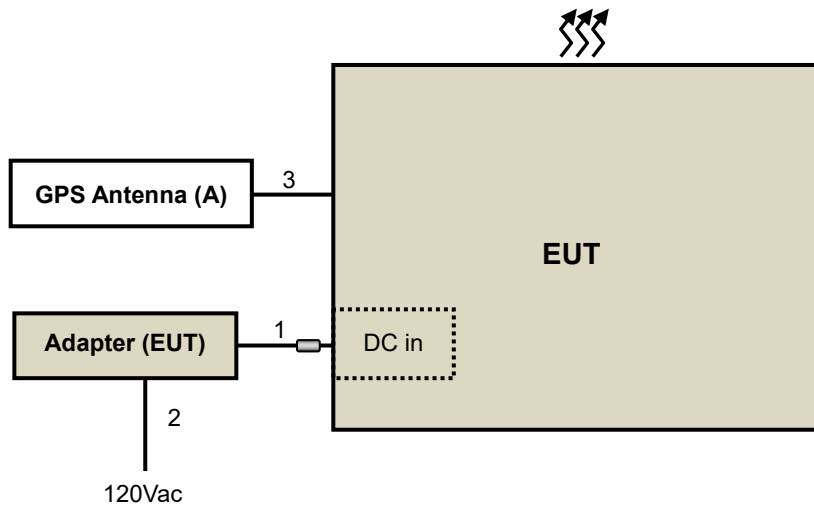

### 3.4 General Description of Applied Standard and references

The EUT is a RF Product. According to the specifications of the manufacturer, it must comply with the requirements of the following standards and references:

**Test standard:**

**FCC Part 15, Subpart C (15.247)**

**ANSI C63.10-2013**

All test items have been performed and recorded as per the above standards.

**References Test Guidance:**

**KDB 558074 D01 15.247 Meas Guidance v05r02**

**KDB 662911 D01 Multiple Transmitter Output v02r01**

All test items have been performed as a reference to the above KDB test guidance.

**Test standard:**

**FCC Part 15, Subpart E (15.407)**

**ANSI C63.10-2013**

All test items have been performed and recorded as per the above standards.

**References Test Guidance:**

**KDB 789033 D02 General UNII Test Procedure New Rules v02r01**

**KDB 662911 D01 Multiple Transmitter Output v02r01**

All test items have been performed as a reference to the above KDB test guidance.

**Test Standard:**

**FCC 47 CFR Part 2**

**FCC 47 CFR Part 22**

**ANSI 63.26-2015**

All test items have been performed and recorded as per the above standards.

**References Test Guidance:**

**KDB 971168 D01 Power Meas License Digital Systems v03r01**

**ANSI/TIA/EIA-603-E 2016**

All test items have been performed as a reference to the above KDB test guidance.

**Test Standard:**

**FCC 47 CFR Part 2**

**FCC 47 CFR Part 24**

**ANSI 63.26-2015**

All test items have been performed and recorded as per the above standards.

**References Test Guidance:**

**KDB 971168 D01 Power Meas License Digital Systems v03r01**

**ANSI/TIA/EIA-603-E 2016**

All test items have been performed as a reference to the above KDB test guidance.

**Test Standard:**

**CC 47 CFR Part 2**

**FCC 47 CFR Part 27**

**ANSI 63.26-2015**

All test items have been performed and recorded as per the above standards.

**References Test Guidance:**

**KDB 971168 D01 Power Meas License Digital Systems v03r01**

**ANSI/TIA/EIA-603-E 2016**

All test items have been performed as a reference to the above KDB test guidance.

**Test Standard:**

**FCC 47 CFR Part 2**

**FCC 47 CFR Part 90**

**ANSI 63.26-2015**

All test items have been performed and recorded as per the above standards.

**References Test Guidance:**

**KDB 971168 D01 Power Meas License Digital Systems v03r01**

**KDB 971168 D02 Misc Rev Approv License Devices v02r01**

**ANSI/TIA/EIA-603-E 2016**

All test items have been performed as a reference to the above KDB test guidance.

## 4 Test Types and Results

### 4.1 Radiated Emission and Bandedge Measurement

#### 4.1.1 Limits of Radiated Emission and Bandedge Measurement

Radiated emissions which fall in the restricted bands must comply with the radiated emission limits specified as below table.

Frequencies (MHz)	Field Strength (microvolts/meter)	Measurement Distance (meters)
0.009 ~ 0.490	2400/F(kHz)	300
0.490 ~ 1.705	24000/F(kHz)	30
1.705 ~ 30.0	30	30
30 ~ 88	100	3
88 ~ 216	150	3
216 ~ 960	200	3
Above 960	500	3

**NOTE:**

1. The lower limit shall apply at the transition frequencies.
2. Emission level (dBuV/m) = 20 log Emission level (uV/m).
3. For frequencies above 1000MHz, the field strength limits are based on average detector, however, the peak field strength of any emission shall not exceed the maximum permitted average limits, specified above by more than 20dB under any condition of modulation.

## 4.1.2 Test Instruments

DESCRIPTION & MANUFACTURER	MODEL NO.	SERIAL NO.	CALIBRATED DATE	CALIBRATED UNTIL
HP Preamplifier	8447D	2432A03504	Feb. 19, 2020	Feb. 18, 2021
HP Preamplifier	8449B	3008A01201	Feb. 20, 2020	Feb. 19, 2021
MITEQ Preamplifier	AMF-6F-260400-33-8P	892164	Feb. 19, 2020	Feb. 18, 2021
Agilent TEST RECEIVER	N9038A	MY51210129	Mar. 18, 2020	Mar. 17, 2021
Schwarzbeck Antenna	VULB 9168	139	Nov. 7, 2019	Nov. 6, 2020
Schwarzbeck Antenna	VHBA 9123	480	Jun. 3, 2019	Jun. 2, 2021
Schwarzbeck Horn Antenna	BBHA-9170	212	Nov. 24, 2019	Nov. 23, 2020
Schwarzbeck Horn Antenna	BBHA 9120-D1	D130	Nov. 24, 2019	Nov. 23, 2020
ADT. Turn Table	TT100	0306	NA	NA
ADT. Tower	AT100	0306	NA	NA
Software	Radiated_V7.6.15.9.5	NA	NA	NA
SUHNER RF cable With 4dB PAD	SF102	Cable-CH6-01	Jul. 10, 2019	Jul. 9, 2020
SUHNER RF cable With 3/4dB PAD	SF102	Cable-CH8-3.6m	Jul. 10, 2019	Jul. 9, 2020
KEYSIGHT MIMO Powermeasurement Test set	U2021XA	U2021XA-001	Jun. 11, 2019	Jun. 10, 2020
KEYSIGHT Spectrum Analyzer	N9030A	MY54490260	Jul. 30, 2019	Jul. 29, 2020
Loop Antenna EMCI	LPA600	270	Aug. 23, 2019	Aug. 22, 2021
EMCO Horn Antenna	3115	00028257	Nov. 24, 2019	Nov. 23, 2020
Highpass filter Wainwright Instruments	WHK 3.1/18G-10SS	SN 8	NA	NA
ROHDE & SCHWARZ Spectrum Analyzer	FSV40	101042	Sep. 23, 2019	Sep. 22, 2020
Anritsu Power Sensor	MA2411B	0738404	Apr. 16, 2019	Apr. 15, 2020
Anritsu Power Meter	ML2495A	0842014	Apr. 16, 2019	Apr. 15, 2020

- NOTE:**
1. The calibration interval of the above test instruments is 12/24 months. And the calibrations are traceable to NML/ROC and NIST/USA.
  2. The horn antenna and HP preamplifier (model: 8449B) are used only for the measurement of emission frequency above 1GHz if tested.
  3. The test was performed in Chamber No. 6.

#### 4.1.3 Test Procedure

##### **For Radiated emission below 30MHz**

- a. The EUT was placed on the top of a rotating table 0.8 meters above the ground at a 3 meter chamber room. The table was rotated 360 degrees to determine the position of the highest radiation.
- b. The EUT was set 3 meters away from the interference-receiving antenna, which was mounted on the top of a variable-height antenna tower.
- c. Parallel, Perpendicular and Ground-parallel of the antenna are set to make the measurement.
- d. For each suspected emission, the EUT was arranged to its worst case and the rotatable table was turned from 0 degrees to 360 degrees to find the maximum reading.
- e. The test-receiver system was set to Quasi-Peak Detect Function and Specified Bandwidth with Maximum Hold Mode.

##### **NOTE:**

1. The resolution bandwidth and video bandwidth of test receiver/spectrum analyzer is 9kHz at frequency below 30MHz.

##### **For Radiated emission above 30MHz**

- a. The EUT was placed on the top of a rotating table 0.8 meters (for 30MHz ~ 1GHz) / 1.5 meters (for above 1GHz) above the ground at 3 meter chamber room for test. The table was rotated 360 degrees to determine the position of the highest radiation.
- b. The EUT was set 3 meters away from the interference-receiving antenna, which was mounted on the top of a variable-height antenna tower.
- c. The height of antenna is varied from one meter to four meters above the ground to determine the maximum value of the field strength. Both horizontal and vertical polarizations of the antenna are set to make the measurement.
- d. For each suspected emission, the EUT was arranged to its worst case and then the antenna was tuned to heights from 1 meter to 4 meters and the rotatable table was turned from 0 degrees to 360 degrees to find the maximum reading.
- e. The test-receiver system was set to quasi-peak detect function and specified bandwidth with maximum hold mode when the test frequency is below 1 GHz.
- f. The test-receiver system was set to peak and average detect function and specified bandwidth with maximum hold mode when the test frequency is above 1 GHz. If the peak reading value also meets average limit, measurement with the average detector is unnecessary.

##### **Note:**

1. The resolution bandwidth and video bandwidth of test receiver/spectrum analyzer is 120kHz for Quasi-peak detection (QP) at frequency below 1GHz.
2. The resolution bandwidth of test receiver/spectrum analyzer is 1 MHz and the video bandwidth is 3 MHz for Peak detection (PK) at frequency above 1GHz.
3. The resolution bandwidth of test receiver/spectrum analyzer is 1MHz and the video bandwidth is  $\geq 1/T$  (Duty cycle < 98%) or 10Hz (Duty cycle  $\geq 98\%$ ) for Average detection (AV) at frequency above 1GHz.
4. All modes of operation were investigated and the worst-case emissions are reported.

#### 4.1.4 Deviation from Test Standard

No deviation.



#### 4.1.5 Test Setup

##### For Radiated emission below 30MHz

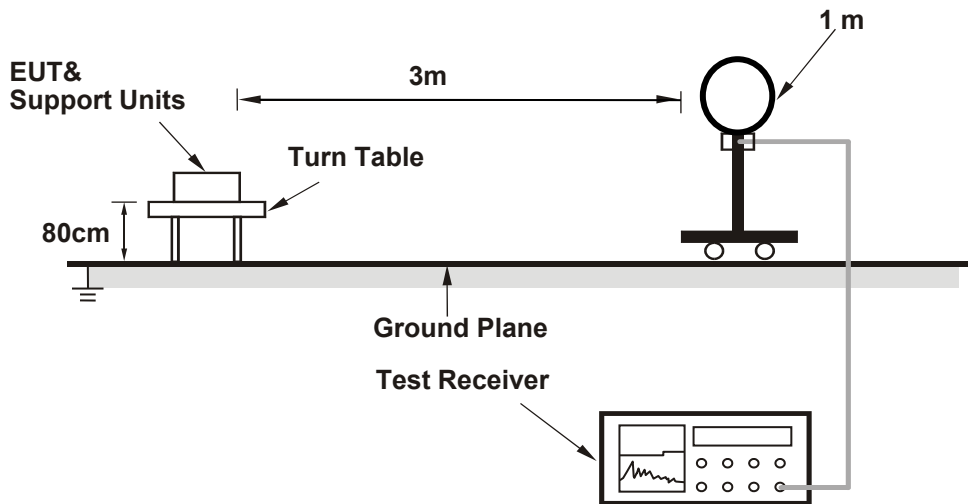

##### For Radiated emission 30MHz to 1GHz

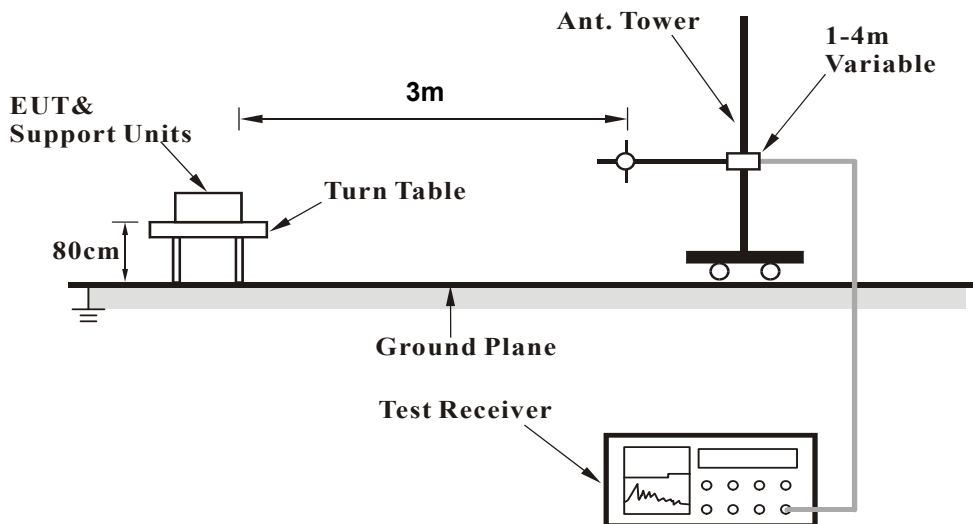

**For Radiated emission above 1GHz**

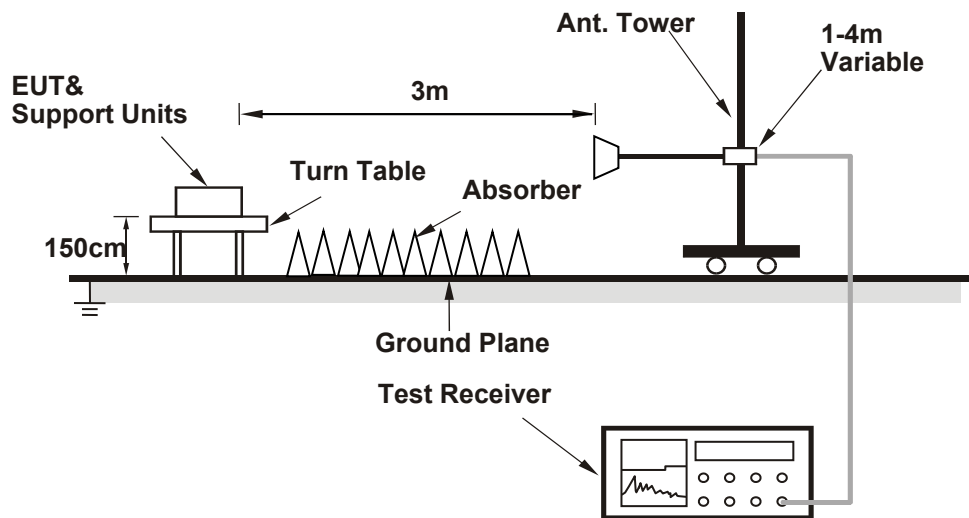

For the actual test configuration, please refer to the attached file (Test Setup Photo).

**4.1.6 EUT Operating Condition**

Set the EUT under transmission condition continuously at specific channel frequency.

## 4.1.7 Test Results

## WCDMA B5 + WiFi 5GHz

<b>FREQUENCY RANGE</b>	1GHz ~ 40GHz	<b>DETECTOR FUNCTION</b>	Peak (PK) Average (AV)
------------------------	--------------	--------------------------	---------------------------

ANTENNA POLARITY & TEST DISTANCE: HORIZONTAL AT 3 M								
NO.	FREQ. (MHz)	EMISSION LEVEL (dBuV/m)	LIMIT (dBuV/m)	MARGIN (dB)	ANTENNA HEIGHT (m)	TABLE ANGLE (Degree)	RAW VALUE (dBuV)	CORRECTION FACTOR (dB/m)
1	1672.80	44.86 PK	74.00	-29.14	1.28 H	49	46.98	-2.12
2	1672.80	34.61 AV	54.00	-19.39	1.28 H	49	36.73	-2.12
3	5350.00	61.68 PK	74.00	-12.32	1.58 H	169	51.43	10.25
4	5350.00	49.28 AV	54.00	-4.72	1.58 H	169	39.03	10.25
5	#10480.00	59.41 PK	68.20	-8.79	1.45 H	218	43.19	16.22
ANTENNA POLARITY & TEST DISTANCE: VERTICAL AT 3 M								
NO.	FREQ. (MHz)	EMISSION LEVEL (dBuV/m)	LIMIT (dBuV/m)	MARGIN (dB)	ANTENNA HEIGHT (m)	TABLE ANGLE (Degree)	RAW VALUE (dBuV)	CORRECTION FACTOR (dB/m)
1	1672.80	46.17 PK	74.00	-27.83	2.03 V	138	48.29	-2.12
2	1672.80	35.32 AV	54.00	-18.68	2.03 V	138	37.44	-2.12
3	5350.00	62.89 PK	74.00	-11.11	1.10 V	317	52.64	10.25
4	5350.00	49.32 AV	54.00	-4.68	1.10 V	317	39.07	10.25
5	#10480.00	61.41 PK	68.20	-6.79	1.88 V	308	45.19	16.22

## REMARKS:

1. Emission Level(dBuV/m) = Raw Value(dBuV) + Correction Factor(dB/m)
2. Correction Factor(dB/m) = Antenna Factor(dB/m) + Cable Factor(dB) – Pre-Amplifier Factor(dB)
3. Margin value = Emission Level – Limit value
4. The other emission levels were very low against the limit.
5. "#": The radiated frequency is out of the restricted band.

### LTE B12 + WiFi 5GHz

<b>FREQUENCY RANGE</b>	1GHz ~ 40GHz	<b>DETECTOR FUNCTION</b>	Peak (PK) Average (AV)
------------------------	--------------	--------------------------	---------------------------

#### ANTENNA POLARITY & TEST DISTANCE: HORIZONTAL AT 3 M

NO.	FREQ. (MHz)	EMISSION LEVEL (dBuV/m)	LIMIT (dBuV/m)	MARGIN (dB)	ANTENNA HEIGHT (m)	TABLE ANGLE (Degree)	RAW VALUE (dBuV)	CORRECTION FACTOR (dB/m)
1	1422.00	43.84 PK	74.00	-30.16	1.27 H	46	47.65	-3.81
2	1422.00	33.59 AV	54.00	-20.41	1.27 H	46	37.40	-3.81
3	5350.00	61.77 PK	74.00	-12.23	1.62 H	165	51.52	10.25
<b>4</b>	<b>5350.00</b>	<b>49.41 AV</b>	<b>54.00</b>	<b>-4.59</b>	<b>1.62 H</b>	<b>165</b>	<b>39.16</b>	<b>10.25</b>
5	#10480.00	59.38 PK	68.20	-8.82	1.42 H	220	43.16	16.22

#### ANTENNA POLARITY & TEST DISTANCE: VERTICAL AT 3 M

NO.	FREQ. (MHz)	EMISSION LEVEL (dBuV/m)	LIMIT (dBuV/m)	MARGIN (dB)	ANTENNA HEIGHT (m)	TABLE ANGLE (Degree)	RAW VALUE (dBuV)	CORRECTION FACTOR (dB/m)
1	1422.00	41.14 PK	74.00	-32.86	2.06 V	141	44.95	-3.81
2	1422.00	35.06 AV	54.00	-18.94	2.06 V	141	38.87	-3.81
3	5350.00	62.74 PK	74.00	-11.26	1.16 V	303	52.49	10.25
4	5350.00	48.96 AV	54.00	-5.04	1.16 V	303	38.71	10.25
5	#10480.00	61.53 PK	68.20	-6.67	1.81 V	310	45.31	16.22

#### REMARKS:

1. Emission Level(dBuV/m) = Raw Value(dBuV) + Correction Factor(dB/m)
2. Correction Factor(dB/m) = Antenna Factor(dB/m) + Cable Factor(dB) – Pre-Amplifier Factor(dB)
3. Margin value = Emission Level – Limit value
4. The other emission levels were very low against the limit.
5. "#": The radiated frequency is out of the restricted band.

## 5 Pictures of Test Arrangements

Please refer to the attached file (Test Setup Photo).

## Appendix – Information of the Testing Laboratories

We, Bureau Veritas Consumer Products Services (H.K.) Ltd., Taoyuan Branch, were founded in 1988 to provide our best service in EMC, Radio, Telecom and Safety consultation. Our laboratories are FCC recognized accredited test firms and accredited according to ISO/IEC 17025.

If you have any comments, please feel free to contact us at the following:

**Lin Kou EMC/RF Lab**

Tel: 886-2-26052180

Fax: 886-2-26051924

**Hsin Chu EMC/RF/Telecom Lab**

Tel: 886-3-6668565

Fax: 886-3-6668323

**Hwa Ya EMC/RF/Safety**

Tel: 886-3-3183232

Fax: 886-3-3270892

**Email:** [service.adt@tw.bureauveritas.com](mailto:service.adt@tw.bureauveritas.com)

**Web Site:** [www.bureauveritas-adt.com](http://www.bureauveritas-adt.com)

The address and road map of all our labs can be found in our web site also.

--- END ---