



REPORT

Issued by an FCC listed Laboratory Reg. no. 93866.
The test site complies with RSS-Gen, IC file no. 3482A-1



Contact person

Andreas Johnson
Electronics
+46 10 516 57 86
andreas.johnson@sp.se

Date

2014-06-09

Reference

4P00903-03-F27

Page

1 (2)

Ericsson AB
Klaes Holm
PDU HW
164 80 Stockholm

Radio measurements on AIR 21 B4A B12P B8P 1700/2100 MHz radio equipment with FCC ID: TA8AKRC118057-1 and IC: 287AB-AS1180571

(5 appendices)

Test object

Product name: AIR 21 B4A B12P B8P
Product number: KRC 118 057/1, R1A

Summary

See appendix 1 for general information and appendix 5 for external photos.

Standard	Compliant	Appendix
FCC CFR 47 / IC RSS-139 Issue 2		
2.1046 / RSS-139 6.4 RF power output	Yes	2
2.1051 / RSS-139 6.5 Spurious emission at antenna terminals	Yes	3
2.1053 / RSS-139 6.5 Field strength of spurious radiation	Yes	4

Note: Above RSS-139 items are given as cross-reference only. Measurements were performed according to ANSI procedures referenced by FCC and covered by SP's accreditation.

SP Technical Research Institute of Sweden Electronics - EMC

Performed by

Examined by

Jörgen Wassholm

Krister Kilbrandt

SP Technical Research Institute of Sweden

Postal address

SP
Box 857
SE-501 15 BORÅS
Sweden

Office location

Västeråsen
Brinellgatan 4
SE-504 62 BORÅS

Phone / Fax / E-mail

+46 10 516 50 00
+46 33 13 55 02
info@sp.se

Laboratories are accredited by the Swedish Board for Accreditation and Conformity Assessment (SWEDAC) under the terms of Swedish legislation. This report may not be reproduced other than in full, except with the prior written approval of the issuing laboratory.

Table of contents

Description of the test object	Appendix 1
Operation mode during measurements	Appendix 1
Test setups	Appendix 1
Purpose of test	Appendix 1
RF power output	Appendix 2
Spurious emission at antenna terminals	Appendix 3
Field strength of spurious radiation	Appendix 4
External photos	Appendix 5

Appendix 1

Description of the test object

Equipment:	Product name: AIR 21 B4A B12P B8P Product number: KRC 118 057/1, R1A FCC ID TA8AKRC118057-1 IC 287AB-AS1180571 IC MODEL NO: AS1180571
Tested configuration:	Multi RAT (MR) WCDMA + LTE
Frequency bands:	TX: 2110 – 2155 MHz RX: 1710 – 1755 MHz
Antenna ports:	2 TX/RX ports, (internally connected to integrated Cross-Polarized antenna elements).
RF configurations Multi RAT:	WCDMA + LTE, MIMO 2x2
Maximum nominal RF output power:	RF port A: 1-3 carriers WCDMA or 1-2 carriers LTE (total power 41.8 dBm, 15W) RF port B: A maximum of four carriers at port B allocated according to 1-3 carriers WCDMA + 1-2 carriers LTE (total power 44.8 dBm, 30W)
Antenna type:	Cross- polarized antenna
Antenna gain:	17 dBi
WCDMA modulations:	QPSK, 16QAM and 64QAM
WCDMA channel bandwidths:	4.2 to 5 MHz (configurable in steps of 100/200 kHz)
WCDMA channel spacing:	4.4 to 5 MHz (configurable in steps of 100/200 kHz)
LTE Modulations:	QPSK, 16QAM and 64QAM
LTE Channel bandwidths:	1.4 MHz, 3 MHz, 5 MHz, 10 MHz and 15 MHz.
Nominal supply voltage:	-48VDC

Appendix 1

Operation mode during measurements

MR, WCDMA + LTE

WCDMA measurements were performed with the test object transmitting test models as defined in 3GPP TS 25.141. Test model 1 (TM1) represent QPSK modulation. Test model 5 (TM5) represent 16QAM modulation and Test model 6 (TM6) represent 64QAM modulation.

LTE measurements were performed with the test object transmitting test models as defined in 3GPP TS 36.141. Test model E-TM1.1 represent QPSK modulation, test model E-TM3.2 represent 16QAM modulation and test model E-TM3.1 represent 64QAM modulation.

The settings below were deemed representative for all traffic scenarios when settings with different modulations, channel bandwidths, number of carriers and RF configurations has been tested to find the worst case setting. All measurements were performed with the test object configured for maximum transmit power. The settings below were used for all measurements if not otherwise noted.

WCDMA MIMO mode

TM5:8 HS-PDSCH at 240ksps + 30 DPCH:s at 30 ksps (SF=128)

1 carrier with channel bandwidth 5 MHz

LTE

E-TM1.1

1 carrier with channel bandwidth 1.4MHz.

Measurements were performed with the test object configured for the maximum transmit power applicable for the tested configuration.

Conducted measurements

The conducted measurements were performed on AIR 21 B4A B12P B8P with product number KRC 118 056/1 including the radio unit ARUS B4 1/KRC 118 046 which is identical for AIR 21 B4 B12P B8P with product number KRC 118 057/1 and is representative for conducted TX performance measurements.

The test object was pole mounted and powered with -48 VDC by an external power supply, unless noted otherwise. All TX parameters were measured at port RF A with port RF B terminated into 50 ohm. Complete measurements were made on RF A with additional measurements on RF B to verify that the ports are identical.

Radiated measurements

The test object was pole mounted and powered with -48 VDC by an external power supply. Both RF ports were terminated into 50 ohm.

Purpose of test

The purpose of the tests is to verify compliance to the performance characteristics specified in applicable items of FCC CFR 47 and Industry Canada RSS-139 and RSS-Gen.

Appendix 1

References

Measurements were done according to relevant parts of the following standards:

ANSI 63.4-2009
ANSI/TIA/EIA-603-C-2004
CFR 47 part 2, October 1st, 2012
CFR 47 part 27, October 1st, 2012
3GPP TS 25.141, version 11.4.0
3GPP TS 36.141, version 11.4.0
3GPP TS 37.141, version 11.3.0
RSS-Gen Issue 3
RSS-139 Issue 2

Uncertainties

Measurement and test instrument uncertainties are described in the quality assurance documentation "SP-QD 10885". The uncertainties are calculated with a coverage factor $k=2$ (95% level of confidence).

Compliance evaluation is based on a shared risk principle with respect to the measurement uncertainty.

Reservation

The test results in this report apply only to the particular test object as declared in the report.

Delivery of test object

The test object was delivered 2013-10-18 and 2014-04-14.

Manufacturer's representative

Christer Gustavsson, Ericsson AB.

Test engineers

Andreas Johnson, Tomas Isbring, Tomas Lennhager, Kexin Chen and Jörgen Wassholm, SP.

Test participant

None

Appendix 1

Measurement equipment

	Calibration Due	SP number
Test site Tesla	2017-01	503 881
R&S FSIQ 40	2014-07	503 738
R&S ESU 26	2015-05	901 553
R&S FSQ 40	2014-07	504 143
R&S ESI 26	2014-07	503 292
Control computer with R&S software EMC32 version 8.52.0	-	503 899
High pass filter	2014-07	901 501
High pass filter	2014-07	901 502
High pass filter	2014-07	504 199
High pass filter	2014-09	901 373
High pass filter	2014-09	503 739
High pass filter	2014-07	503 740
RF attenuator	2014-07	504 159
RF attenuator	2014-07	900 233
RF attenuator	2014-07	900 691
RF attenuator	2014-07	901 384
RF attenuator	2014-11	901 508
Chase Bilog Antenna CBL 6111A	2014-10	503 182
EMCO Horn Antenna 3115	2015-09	502 175
Std.gain horn FLANN model 20240-20	-	503 674
µComp Nordic, Low Noise Amplifier	2015-01	901 545
Miteq Low Noise Amplifier	2014-09	503 285
Schwartzbeck preamplifier BBV 9742	2014-14	504 085
Temperature and humidity meter, Testo 635	2014-06	504 203
Temperature and humidity meter, Testo 625	2014-06	504 188
Temperature Chamber	-	501 031
Multimeter Fluke 87	2014-08	502 190

Appendix 1

Test frequencies during radiated and conducted measurements

MR WCDMA+ LTE TX test frequencies

RF A + RF B		RF B		Test configuration with symbolic name	Comment
WCDMA		LTE			
UARFCN (Frequency) Downlink	BW [MHz]	EARFCN (Frequency) Downlink	BW [MHz]		
1537 (2112.4 MHz)	5	2124 (2127.4 MHz)	1.4	B1.4	TX bottom constellation per LTE BW
1600 (2125 MHz)	5	2268 (2141.8 MHz)	1.4	M1.4	TX mid constellation per LTE BW
		2260 (2141 MHz)	3	M3	
		2250 (2140 MHz)	5	M5	
		2225 (2137.5 MHz)	10	M10	
		2200 (2135 MHz)	15	M15	
1670 (2139.0 MHz)	5	2393 (2154.3 MHz)	1.4	T1.4	TX top constellation per LTE BW

All RX frequencies were configured 400 MHz below the corresponding TX frequency according the applicable duplex offset for the operating band.

Appendix 1

Test setup conducted measurements

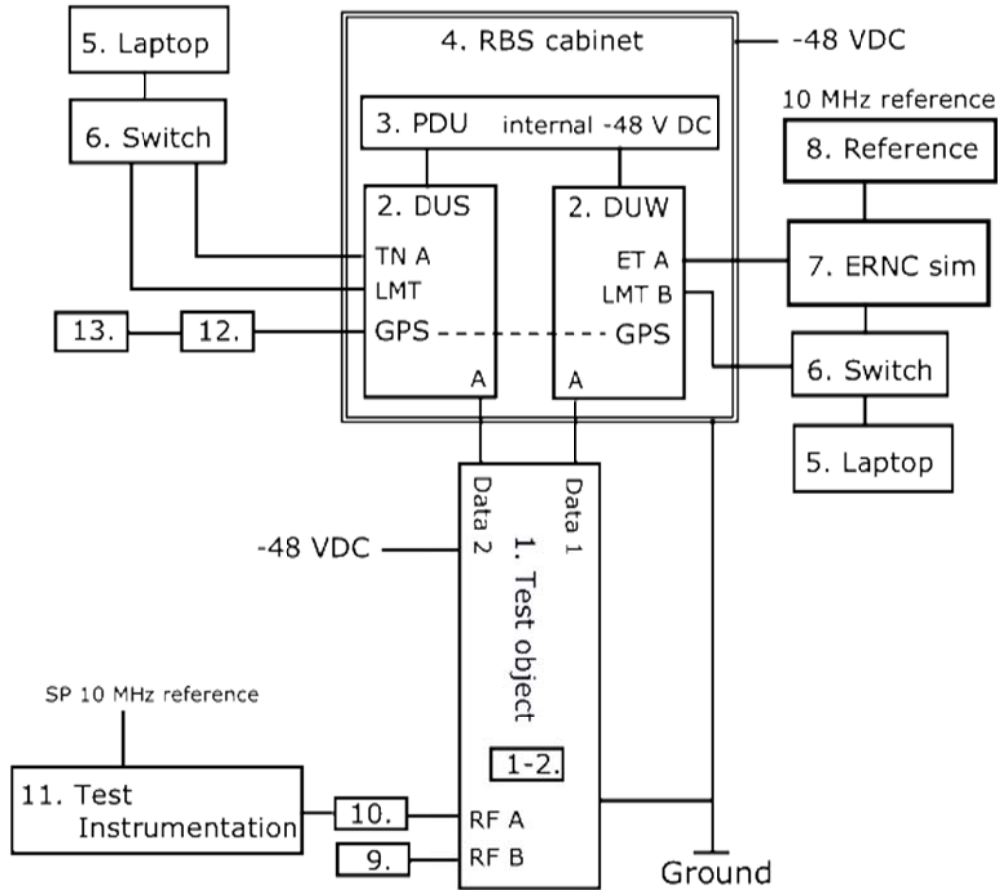

Test object:

1.	AIR 21 B4A B12P B8P, KRC 118 056/1, revision R1A, s/n: CQ30112763 (FCC ID TA8AKRC118056-1 and IC 287AB-AS1180561) with software: CXP 901 3268/6, revision R51NE 1-2. Transciever, ARUS B4 1/KRC 118 046, revision R1C
----	--

Functional test equipment

2.	DUW 30 01, KDU 127 161/3, revision R4F, s/n: TU8XB20902 DUS 41 01, KDU 137 624/1, revision R6A, s/n: A401981869
3.	PDU 02 01, BMG 980 336/4, revision R2A, s/n: BJ31528316
4.	RBS 6201 cabinet, BAMS – 1000778792
5.	Controlling laptop HP EliteBook 8560 w, BAMS – 1001236858
6.	Fast Ethernet switch, Netgear FS726T
7.	ERNC Sim 130, BAMS – 100066091
8.	Symmetricon 8040 reference, BAMS – 1000714189
9.	Terminator, 50 ohm
10.	Attenuator, according respective appendix
11.	SP Test Instrumentation according to measurement equipment list
12.	GPS 02 01, NCD 901 41/1, revision R1D, s/n: TU8K474887
13.	GPS Active Antenna, KRE 101 2082/1

Appendix 1

Test setup radiated measurements

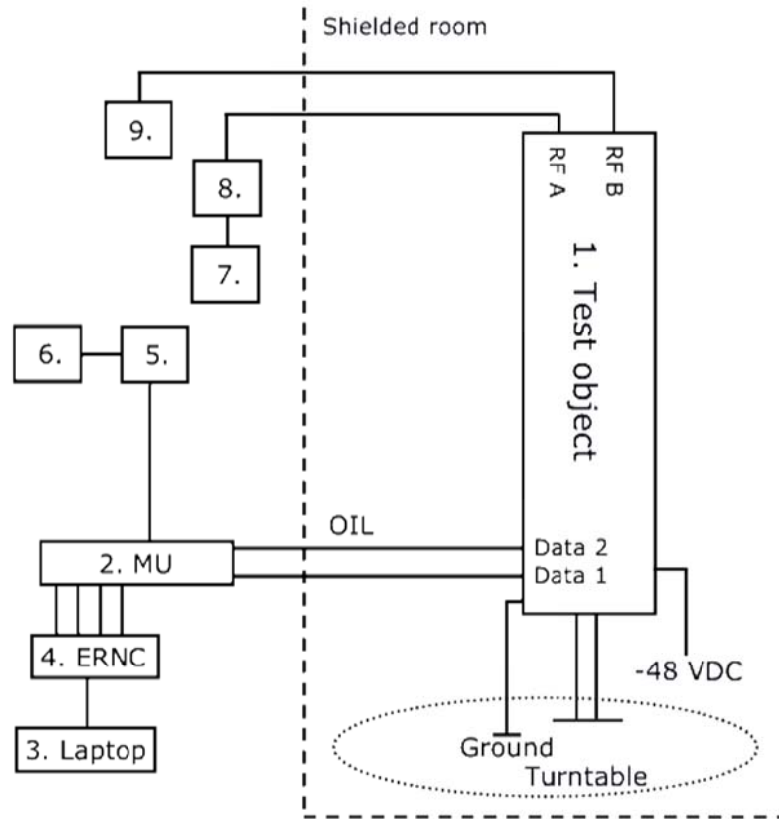

Test object:

1.	AIR 21 B4A B12P B8P, KRC 118 057/1, revision R1A, S/N: TM30005097 (FCC ID TA8AKRC118057-1 and IC 287AB-AS1180571) with software: CXP 901 3268/6, revision R51NL Transceiver, ARUS B4 1/KRC 118 046, revision R1C
----	--

Functional test equipment:

2.	Main Unit SUP 6601, 1/BFL 901 009/4, revision R3B, s/n: BR81174249 DUS 41 01, KDU 137 624/1, revision R3C, s/n: C826152207 SUP 6601, 1/BFL 901 009/1, revision R3B, s/n: BR81174249 DUW 41 01, KDU 127 174/4, revision R2D/A, s/n: TU8XH35179
3.	Laptop, EliteBook 8560w, BAMS – 1001236854
4.	Symmetricom SyncServer S250, BAMS – 1000714182 Switch Netgear FS726T Switch Netgear GSM 7212 10 MHz reference Symmetricom 8040, BAMS – 1000714190
5.	GPS 02 01, NCD 901 41/1, revision R1D, s/n: TU8K388084
6.	GPS Active Antenna, KRE 101 2082/1
7.	FSIQ 40, SP number: 503 738, for supervision purpose only
8.	Attenuator
9.	Terminator 50 ohm

Appendix 1

Interfaces:	Type of port:
Power: -48 VDC	DC Power
Antenna port (A), (passive antenna), 7/16-connector	Antenna
Antenna port (B), (passive antenna), 7/16-connector	Antenna
Data 1, Optical Interface Link, single mode opto fibre	Signal
Data 2, Optical Interface Link, single mode opto fibre	Signal
Ground wire	Ground

RBS software:

RAT	Software	Revision
WCDMA	CXP 902 1719	R5D09
LTE	CXP 102 051/19	R51NF

Appendix 2

RF power output measurements according to CFR 47 §27.50 / IC RSS-139 6.4

Date	Temperature	Humidity
2013-11-13	22 °C ± 3 °C	28 % ± 5 %
2013-11-14	22 °C ± 3 °C	30 % ± 5 %

Test set-up and procedure

The test object was connected to a signal analyzer measuring peak and RMS output power in CDF mode. A resolution bandwidth of 50 MHz was used.

Measurement equipment	SP number
R&S FSQ 40	504 143
RF attenuator	901 508
Testo 635, temperature and humidity meter	504 203

Measurement uncertainty: 1.1 dB

Results

Measured total output power.

Nominal output power at RF A: 41.8 dBm.

Nominal output power at RF B: 44.8 dBm.

Tested configuration With symbolic name	RF A	RF B
	W	L+W
	[RMS dBm/ dB PAR]	[RMS dBm/ dB PAR]
B1.4	41.65/ 8.10	44.47/ 6.90
M1.4	41.75/ 8.10	44.45/ 6.90
M3	41.75/ 8.10	44.59/ 6.92
M5	41.75/ 8.10	44.57/ 7.00
M10	41.75/ 8.10	44.55/ 7.00
M15	41.76/ 8.10	44.52/ 6.97
T1.4	41.68/ 8.10	44.38/ 6.90

Note: The PAR value is the 0.1 % Peak to Average Ratio.

Appendix 2

Measured output power per 1 MHz

Tested configuration with symbolic name	RF A W [RMS dBm]	RF B L+W [RMS dBm]	Total power of WCDMA ¹⁾ [RMS dBm]
B1.4	W=36.59	W=36.45, L=40.70	39.59
M1.4	W=36.67	W=36.36, L=40.54	39.67
M3	W=36.76	W=36.37, L=37.81	39.76
M5	W=36.71	W=36.60, L=36.67	39.71
M10	W=36.72	W=36.47, L=32.87	39.72
M15	W=36.71	W=36.63, L=31.08	39.71
T1.4	W=36.59	W=36.24, L=40.14	36.59

¹⁾: Measured according to FCC KDB662911 D01 Multiple Transmitter Output v02r01. Method E), 2), c). “Measure and add $10 \log(N_{Ant})$ ”.

Limits

§27.50:

There is no maximum output power specified for base stations transmitting in the 2110-2155 MHz band. However, a licensee operating a base or fixed station in the 2110-2155 MHz band utilizing a power greater than 1640 watts EIRP and greater than 1640 watts/MHz EIRP must coordinate such operations in advance with the parties addressed in the rules.

In measuring transmissions in this band using an average power technique, the peak-to-average ratio (PAR) of the transmission may not exceed 13 dB.

RSS-139 6.4:

There is no power limit specified for base station equipment in the RSS-139.

EIRP compliance is addressed at the time of licensing, as required by the responsible IC Bureau. Licensee’s are required to take into account the antenna gain to get the maximum usable power settings to prevent the radiated output power to exceed the ERP/EIRP limits specified in SRSP-513

When the transmitter power is measured in terms of average value, the peak-to-average ratio of the power shall not exceed 13 dB.

Complies?	Yes
-----------	-----

Appendix 3

Conducted spurious emission measurements according to CFR 47 §27.53(h)/ IC RSS-139 6.5

Date	Temperature	Humidity
2013-11-12	21 °C ± 3 °C	35 % ± 5 %
2013-11-13	22 °C ± 3 °C	28 % ± 5 %

Test set-up and procedure

The measurements were made per definition in §27.53(h). The output was connected to a spectrum analyzer with a RBW setting of 1 MHz and RMS detector activated. The spectrum analyzer was connected to an external 10 MHz reference standard during the measurements.

Before comparing the results to the limit, 3 dB [10 log (2)] should be added according to method E), 3), (iii) “measure and add 10 log(N_{ANT})” of FCC KDB662911 D01 Multiple Transmitter Output v02r01.

Measurement equipment	SP number
R&S FSW 43	902 073
RF attenuator	902 282
HP filter	901 502
Testo 635, temperature and humidity meter	504 203

Measurement uncertainty: 3.7 dB

Results

Diagram	Tested configuration with symbolic name	Tested Port
1 a-e	B1.4	RF B
2 a-e	M1.4	RF B
3 a-e	M3	RF B
4 a-e	M5	RF B
5 a-e	M10	RF B
6 a-e	M15	RF B
7 a-e	T1.4	RF B

Appendix 3

Remark

The emission at 9 kHz on the plots was not generated by the test object. A complementary measurement with a smaller RBW showed that it was related to the LO feed-through.

The highest fundamental frequency is 2.155 GHz. The measurements were made up to 22 GHz ($10 \times 2.155 \text{ GHz} = 21.55 \text{ GHz}$).

Limits

§27.53(h) and RSS-139 6.5

Outside a licensee's frequency band(s) of operation the power of any emission shall be attenuated below the transmitter power (P) by at least $43 + 10 \log (P)$ dB, resulting in a limit of -13 dBm per 1 MHz RBW.

Complies?	Yes
-----------	-----

Appendix 3

Diagram 1 a:

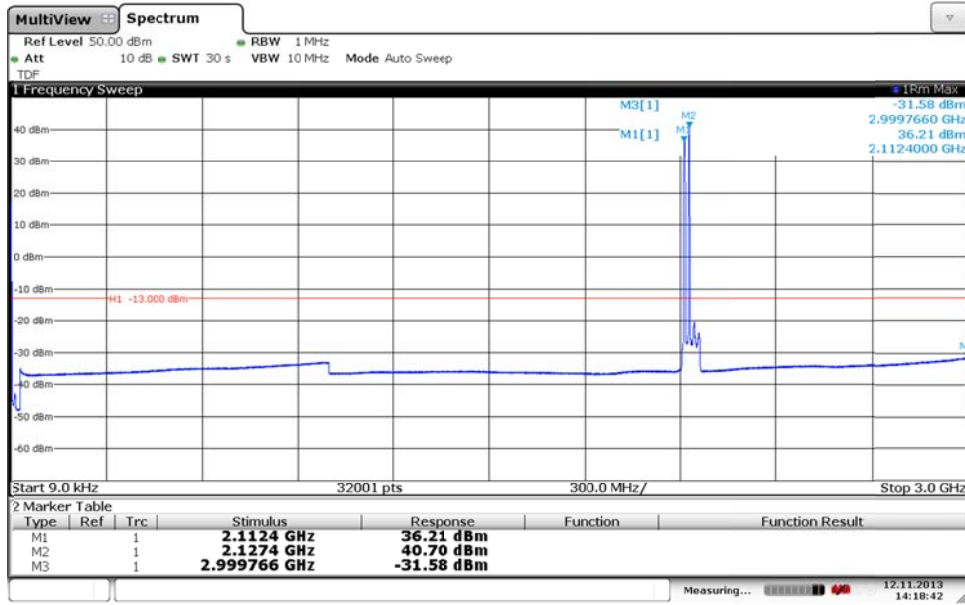

Date: 12 NOV.2013 14:18:41

Diagram 1 b:

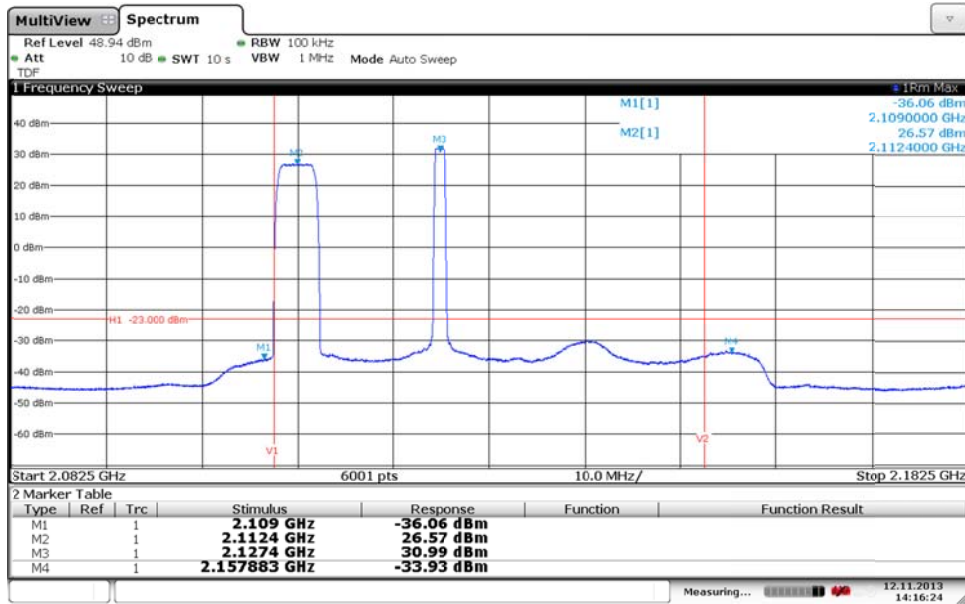

Date: 12 NOV.2013 14:16:24

Appendix 3

Diagram 1 c:

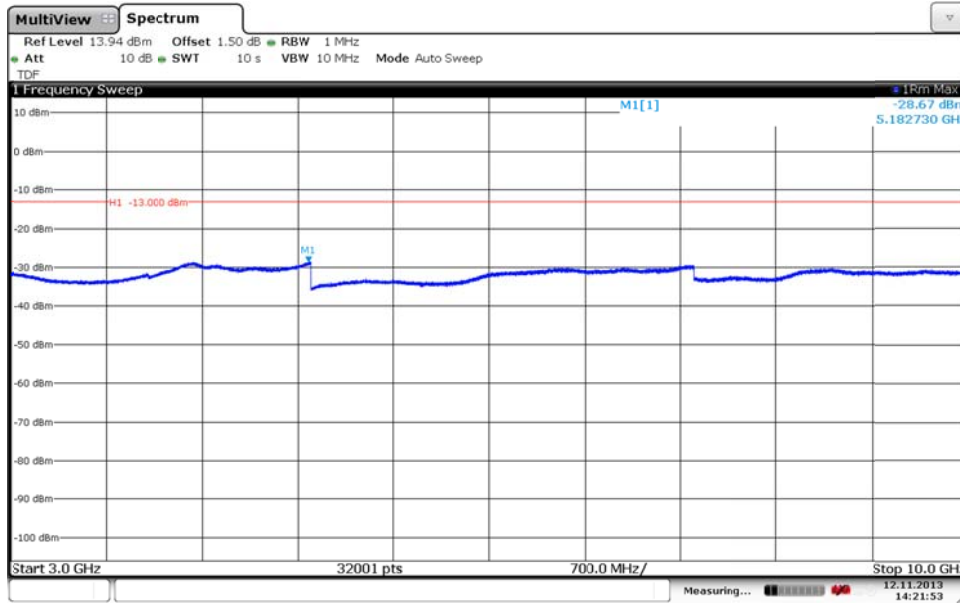

Date: 12.NOV.2013 14:21:52

Diagram 1 d:

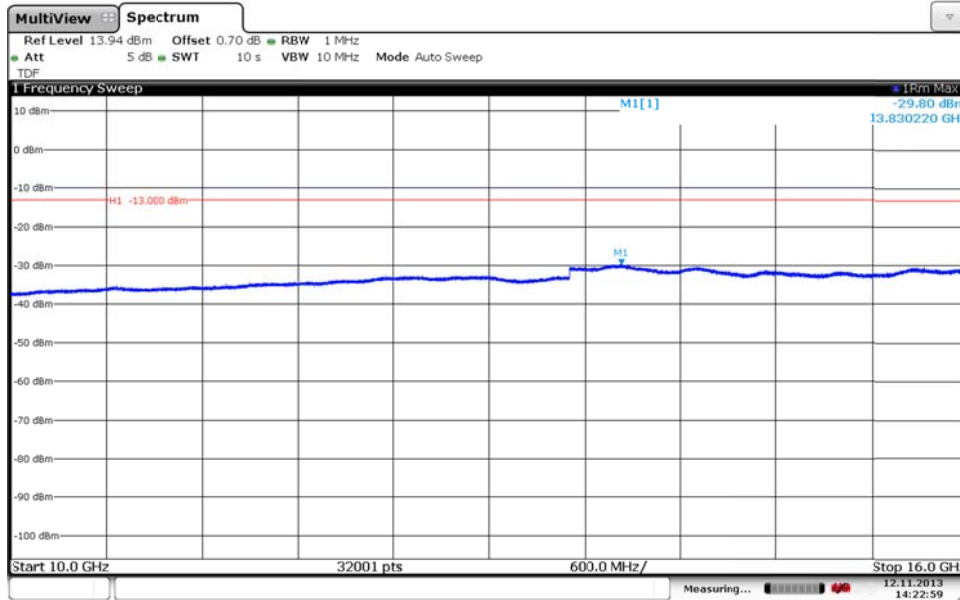

Date: 12.NOV.2013 14:23:00

Appendix 3

Diagram 1 e:

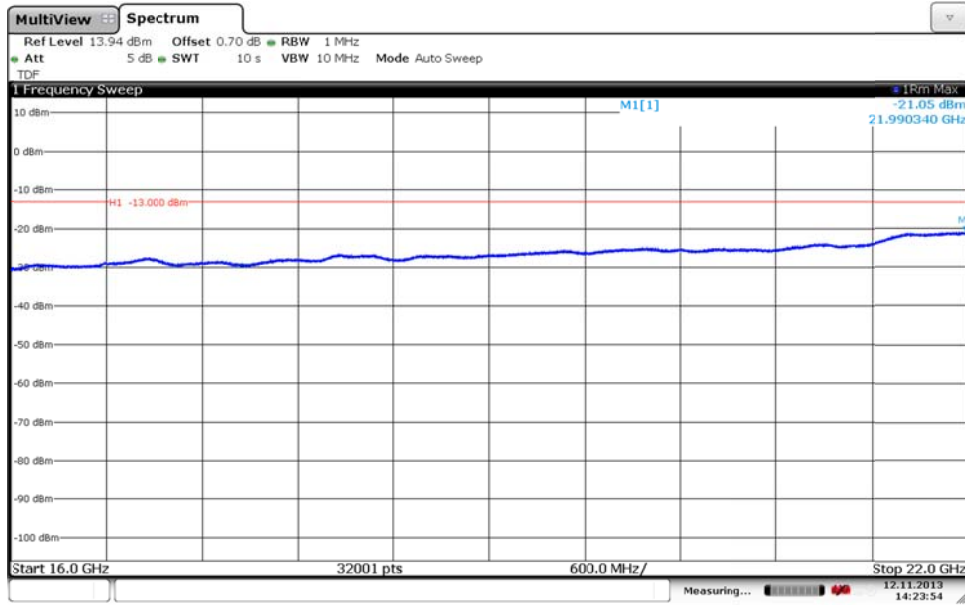

Date: 12 NOV. 2013 14:23:54

Appendix 3

Diagram 2 a:

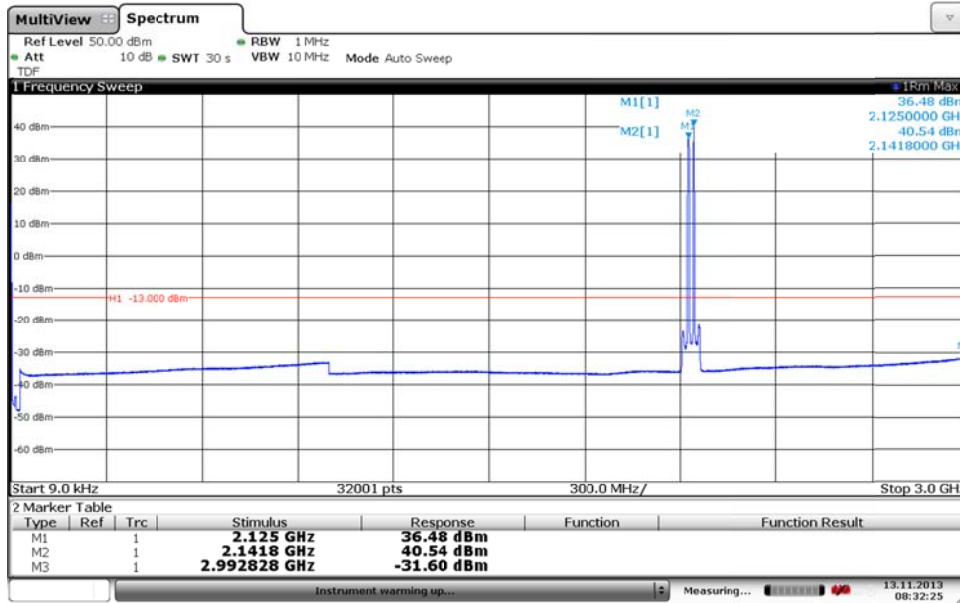

Date: 13.NOV.2013 08:32:25

Diagram 2 b:

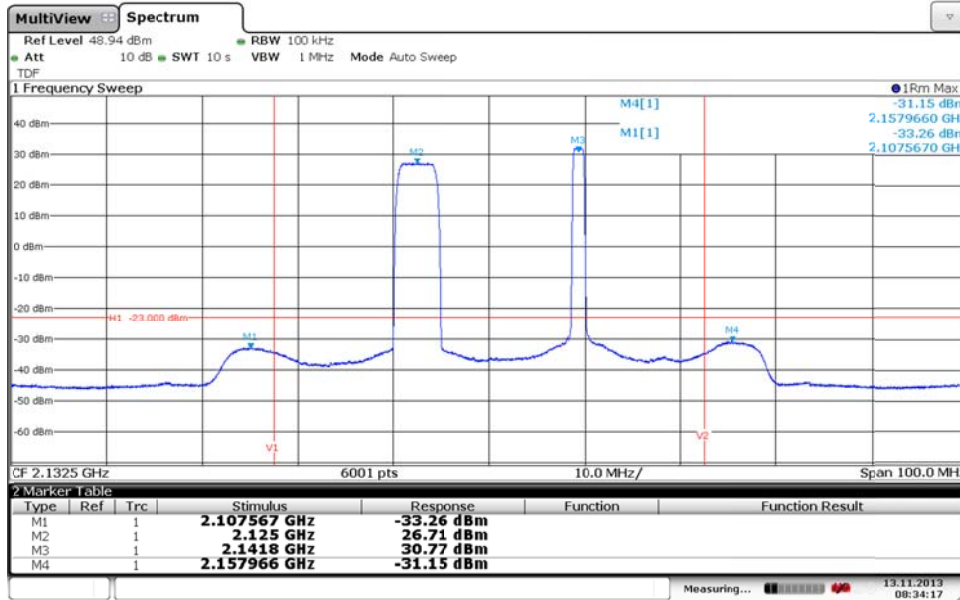

Date: 13.NOV.2013 08:34:18

Appendix 3

Diagram 2 c:

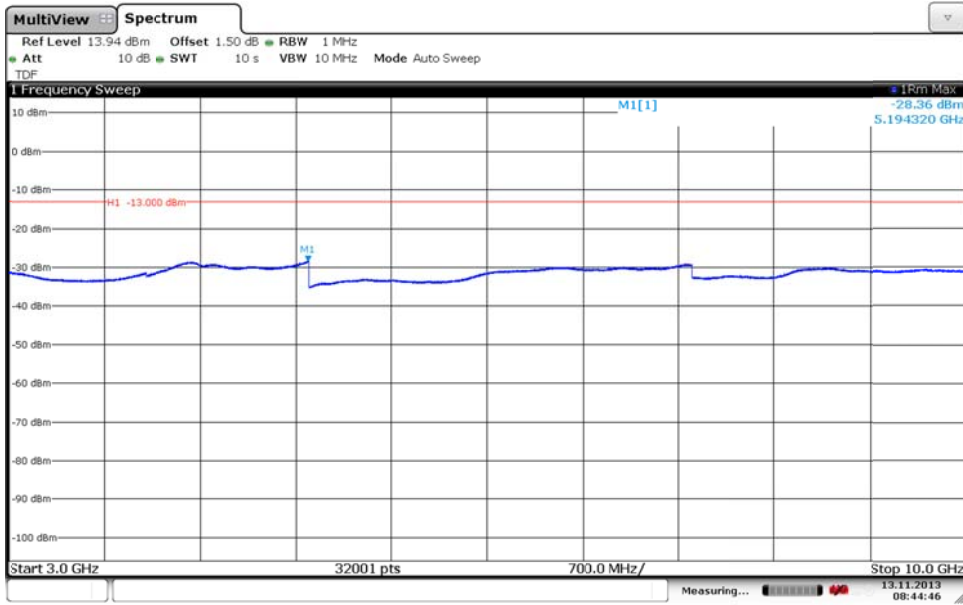

Date: 13.NOV.2013 08:44:46

Diagram 2 d:

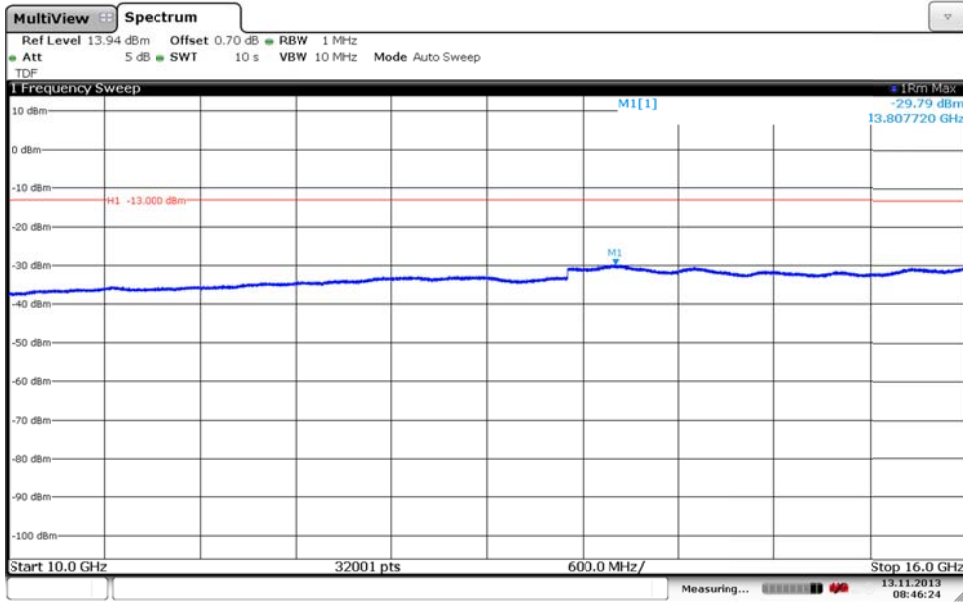

Date: 13.NOV.2013 08:46:24

Appendix 3

Diagram 2 e:

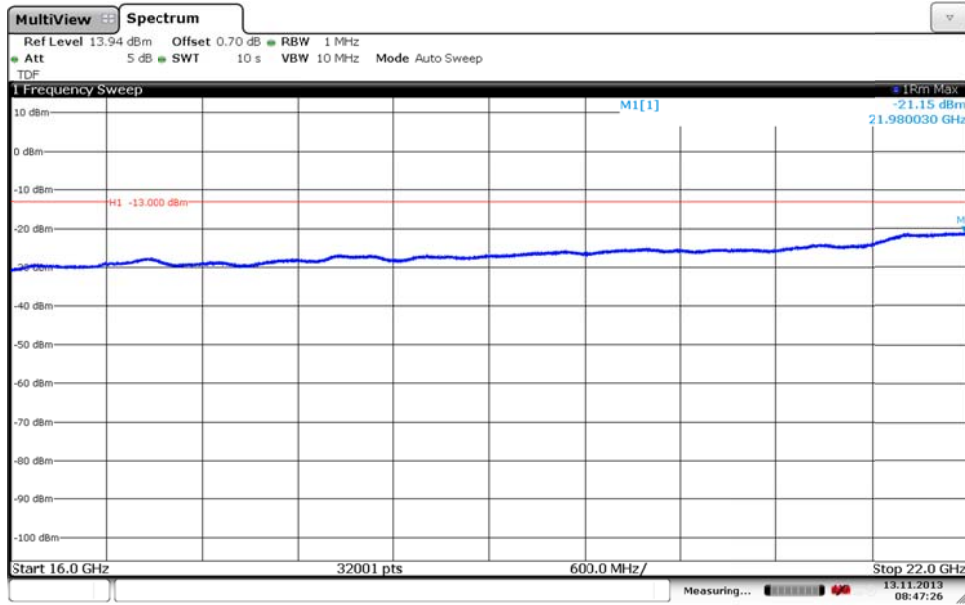

Date: 13.NOV.2013 08:47:26

Appendix 3

Diagram 3 a:

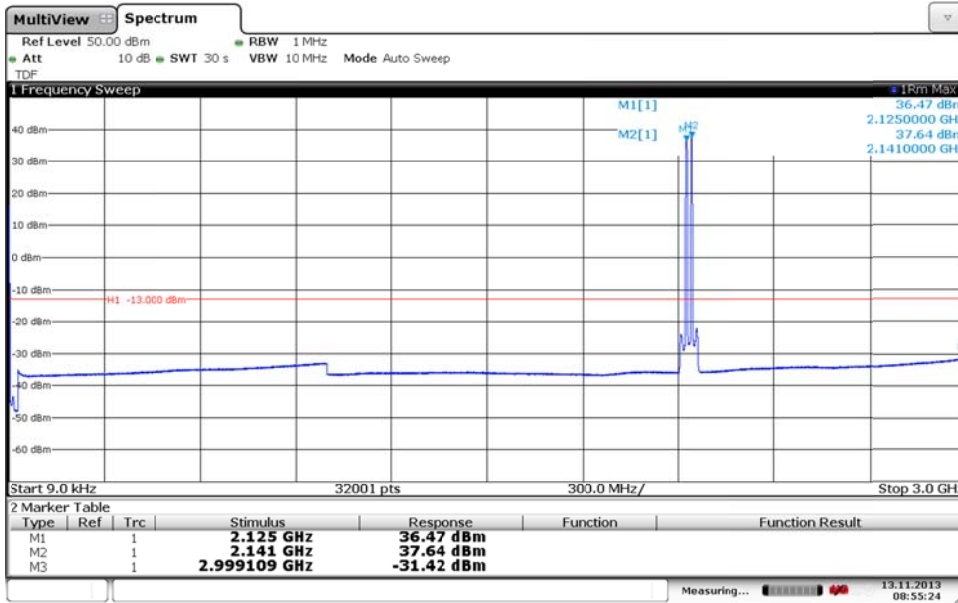

Date: 13.NOV.2013 08:55:24

Diagram 3 b:

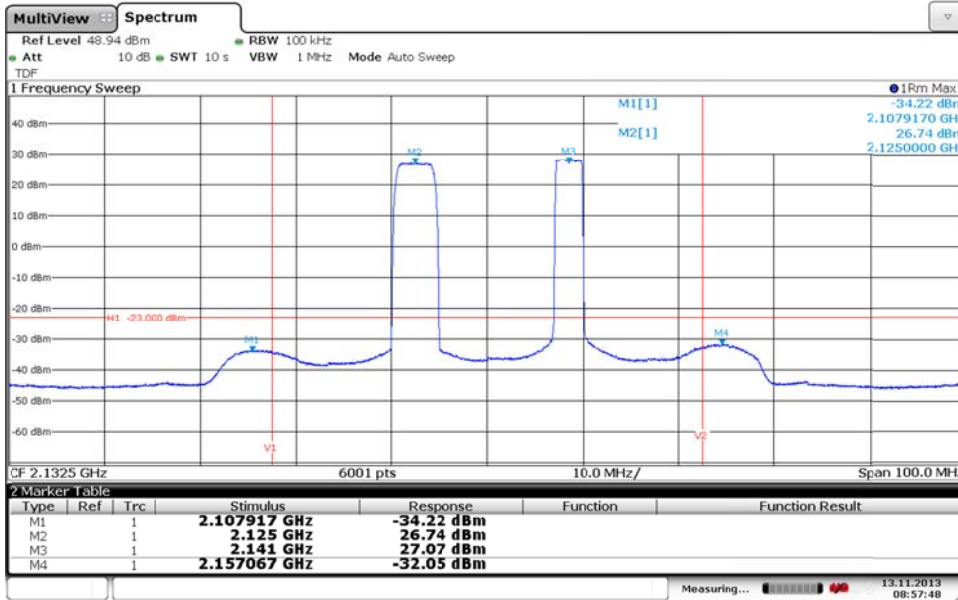

Date: 13.NOV.2013 08:57:48

Appendix 3

Diagram 3 c:

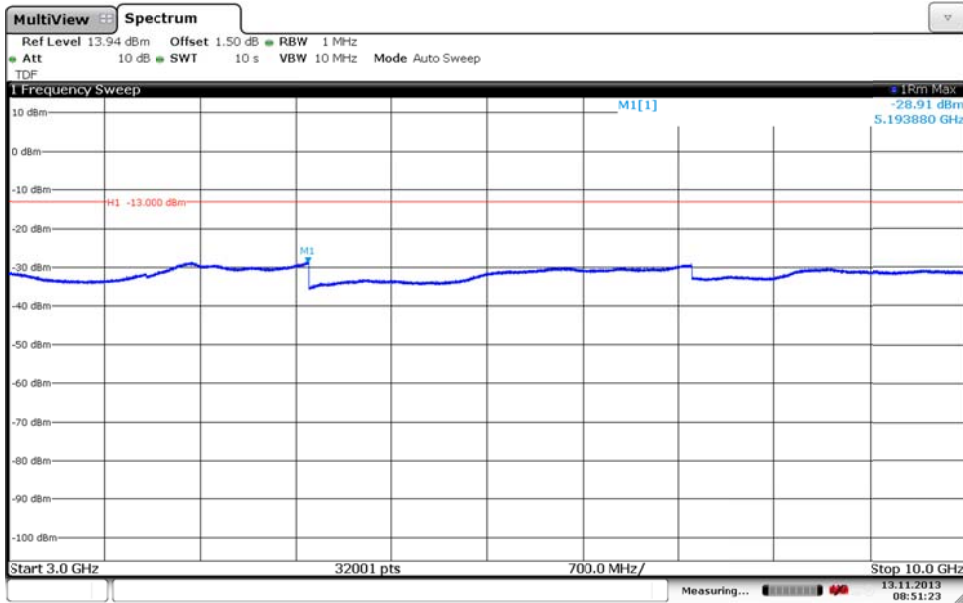

Date: 13.NOV.2013 08:51:22

Diagram 3 d:

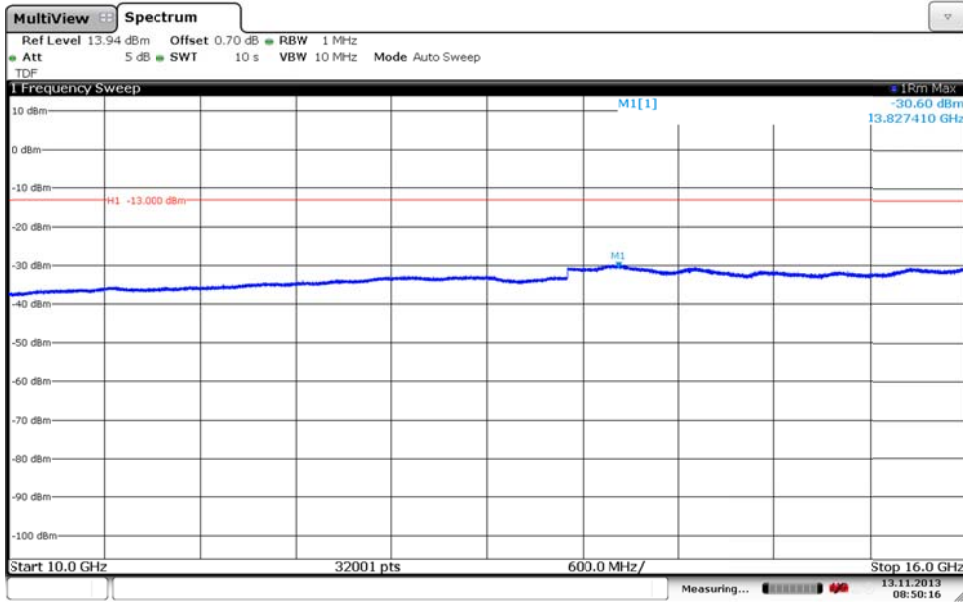

Date: 13.NOV.2013 08:50:16

Appendix 3

Diagram 3 e:

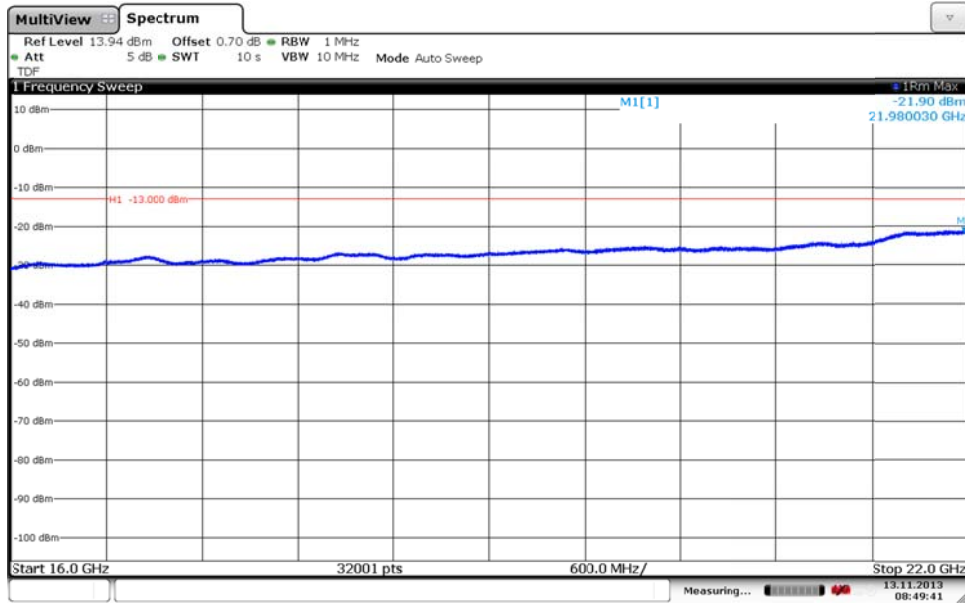

Date: 13.NOV.2013 08:49:41

Appendix 3

Diagram 4 a:

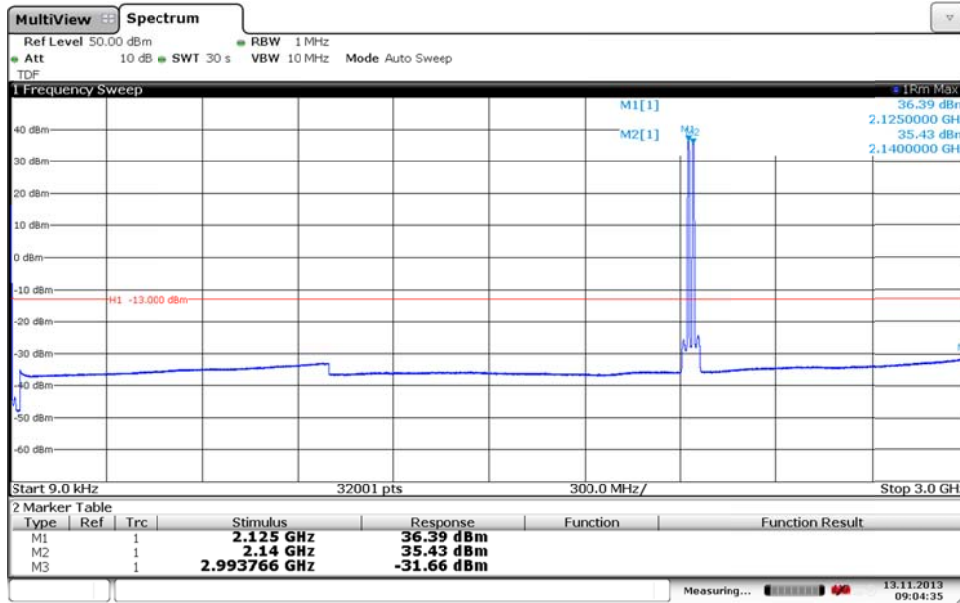

Date: 13.NOV.2013 09:04:35

Diagram 4b:

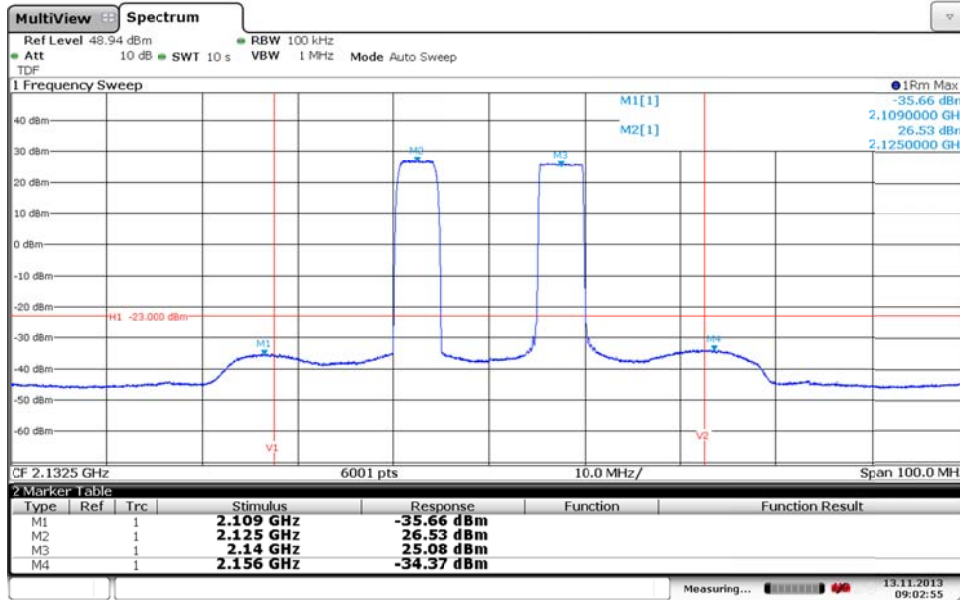

Date: 13.NOV.2013 09:02:55

Appendix 3

Diagram 4 c:

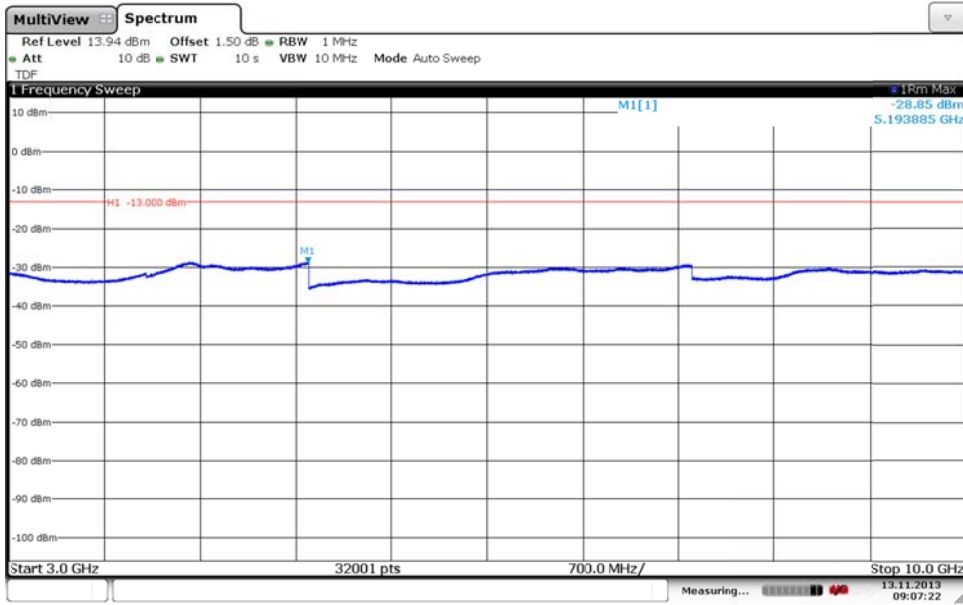

Date: 13.NOV.2013 09:07:22

Diagram 4 d:

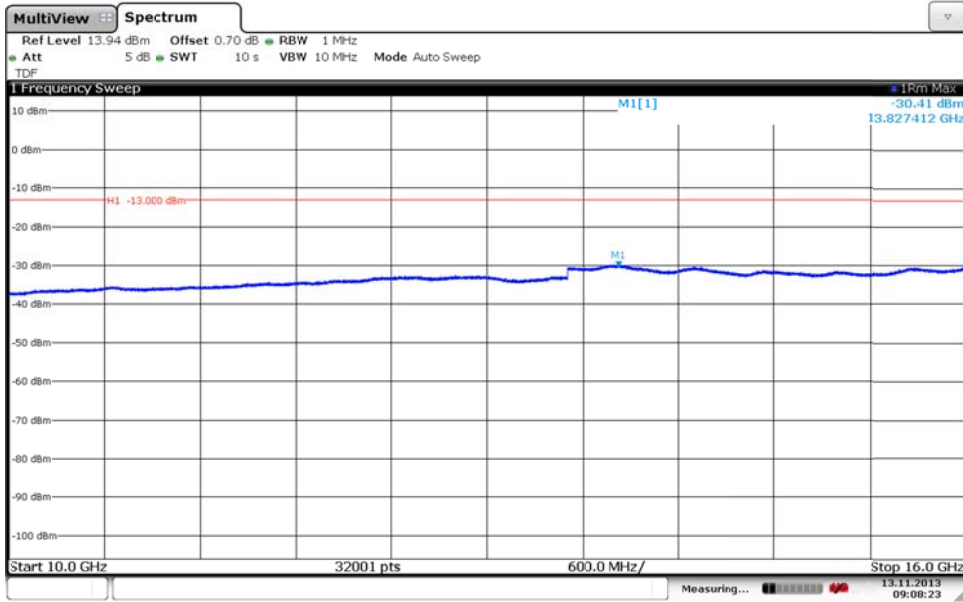

Date: 13.NOV.2013 09:08:23

Appendix 3

Diagram 4 e:

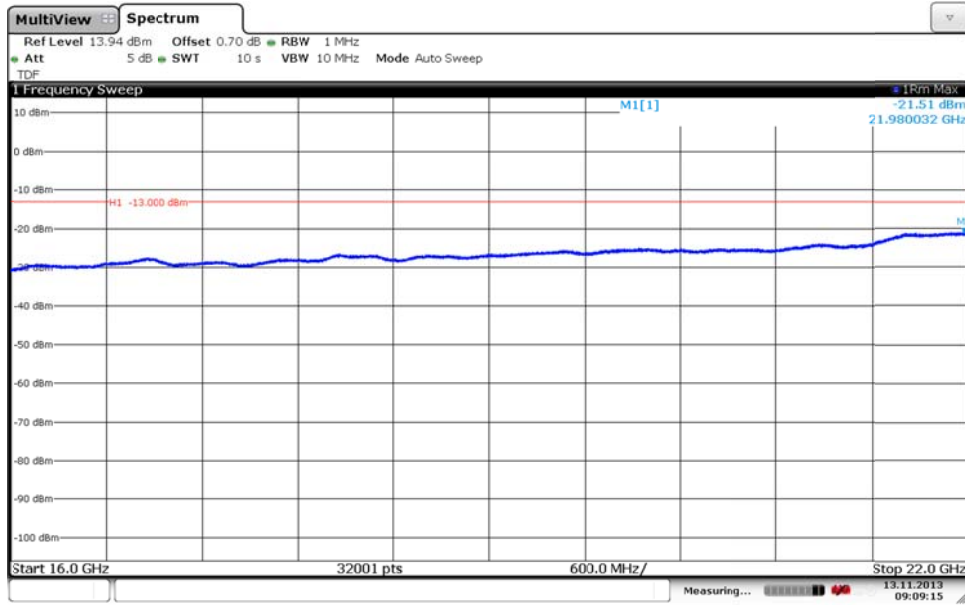

Date: 13.NOV.2013 09:09:16

Appendix 3

Diagram 5 a:

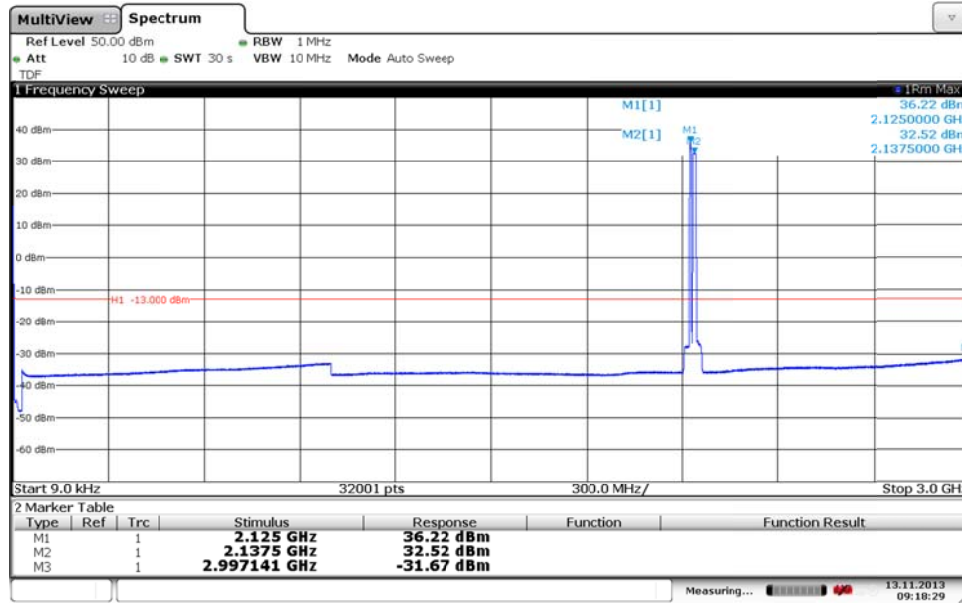

Date: 13.NOV.2013 09:18:29

Diagram 5 b:



Date: 13.NOV.2013 09:19:35

Appendix 3

Diagram 5 c:

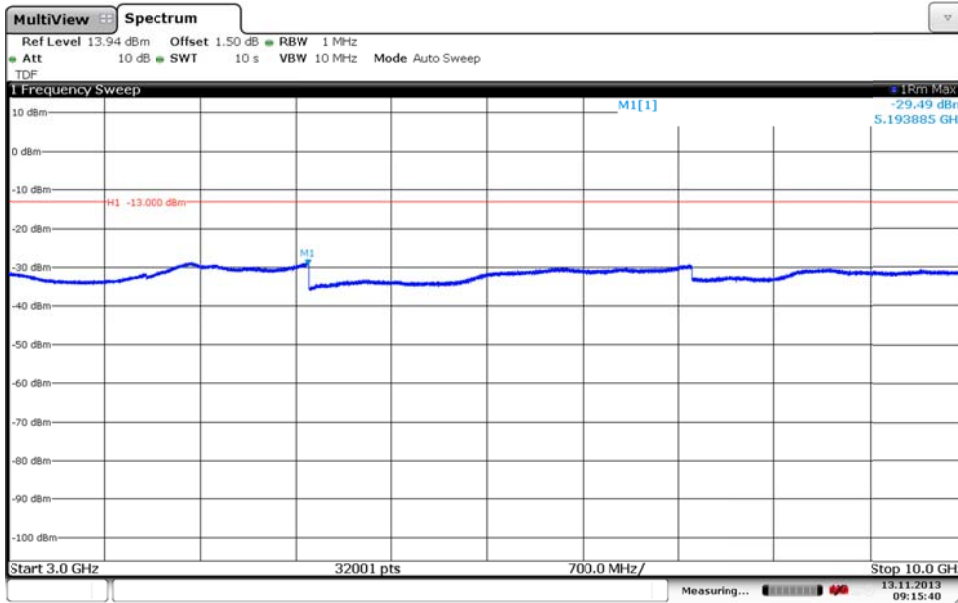

Date: 13.NOV.2013 09:15:40

Diagram 5 d:

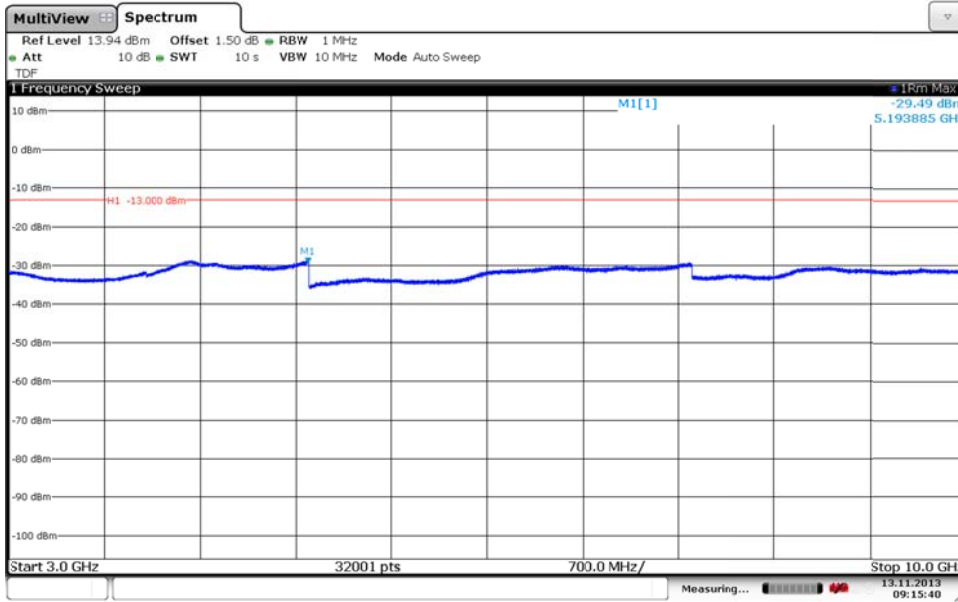

Date: 13.NOV.2013 09:15:40

Appendix 3

Diagram 5 e:

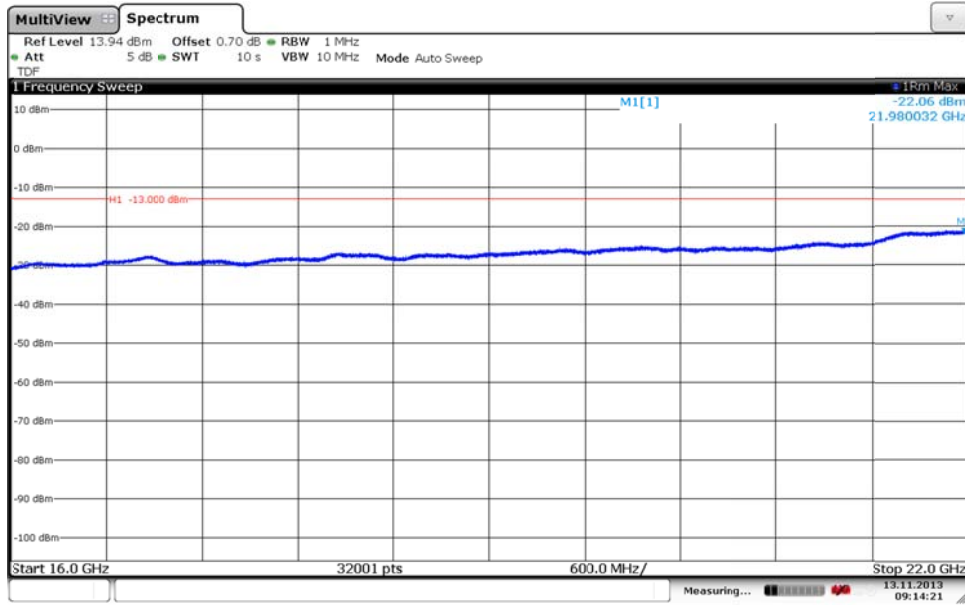

Date: 13.NOV.2013 09:14:20

Appendix 3

Diagram 6 a:



Date: 13.NOV.2013 09:25:26

Diagram 6 b:

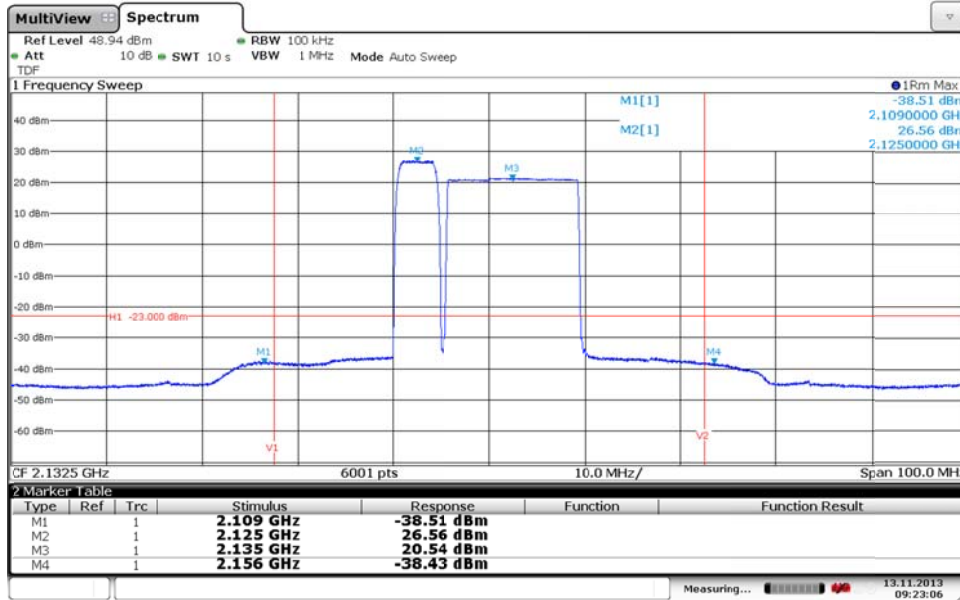

Date: 13.NOV.2013 09:23:06

Appendix 3

Diagram 6 c:

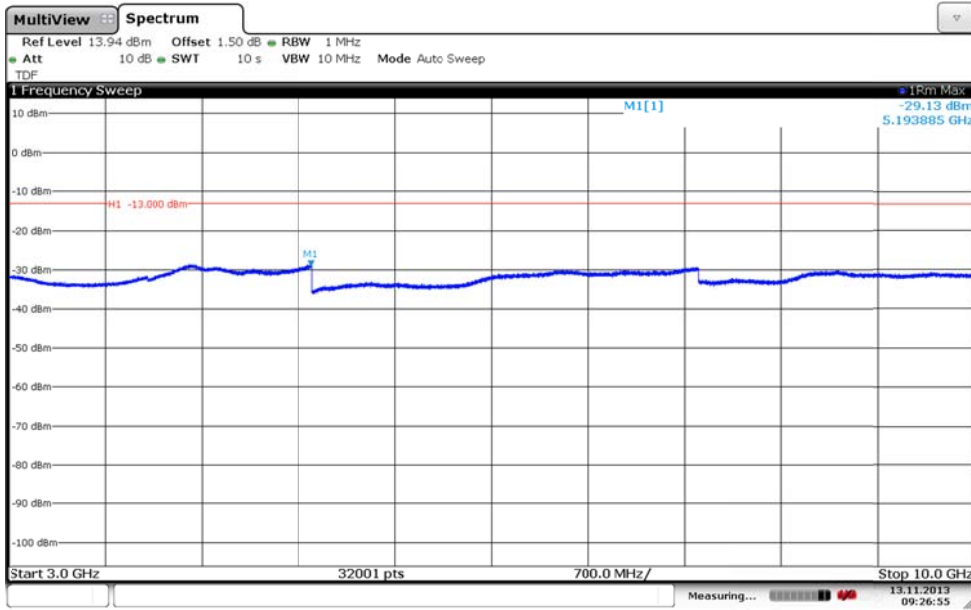
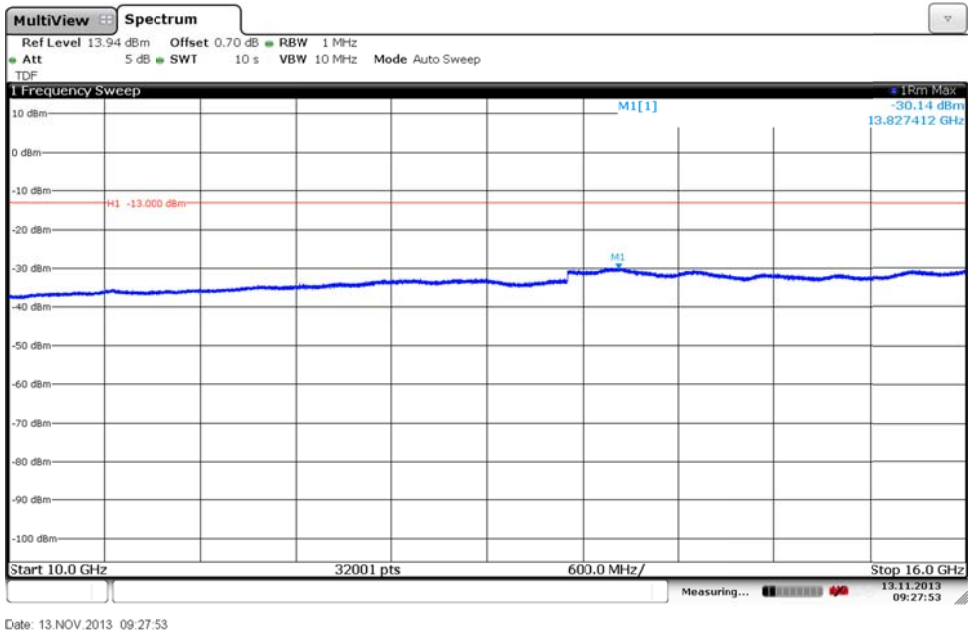
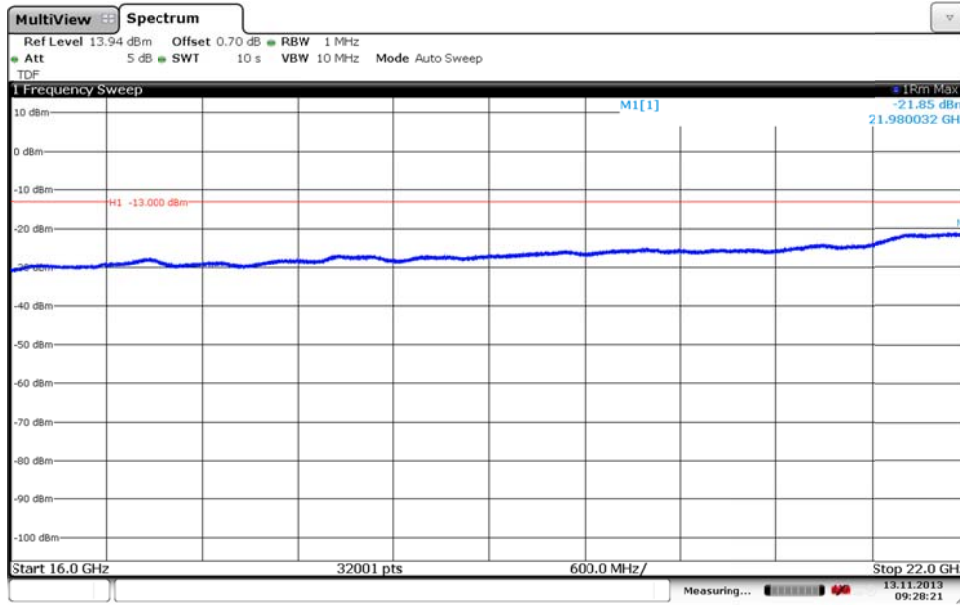

Diagram 6 d:



Appendix 3

Diagram 6 e:



Date: 13.NOV.2013 09:28:21

Appendix 3

Diagram 7 a:

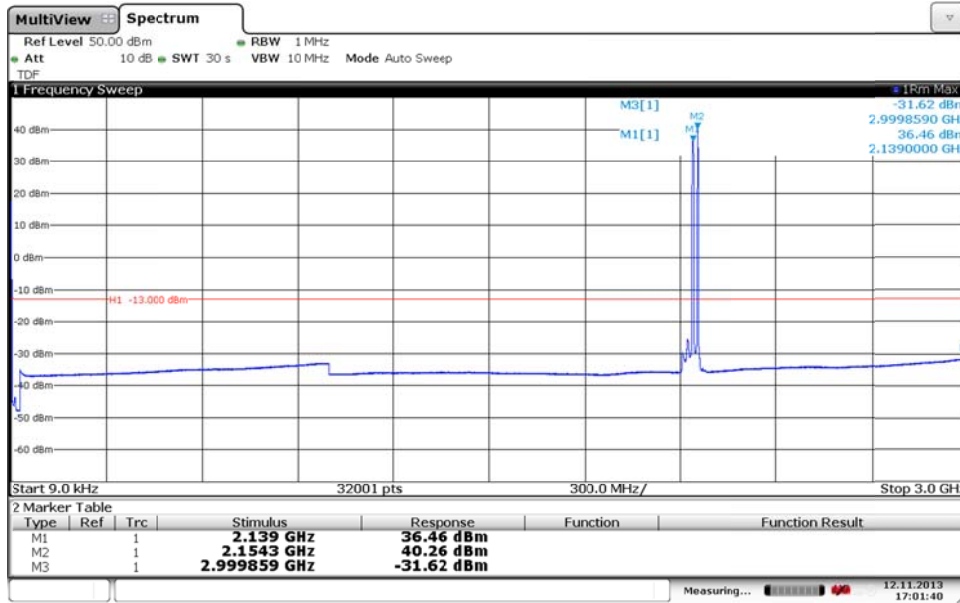

Date: 12 NOV.2013 17:01:40

Diagram 7 b:

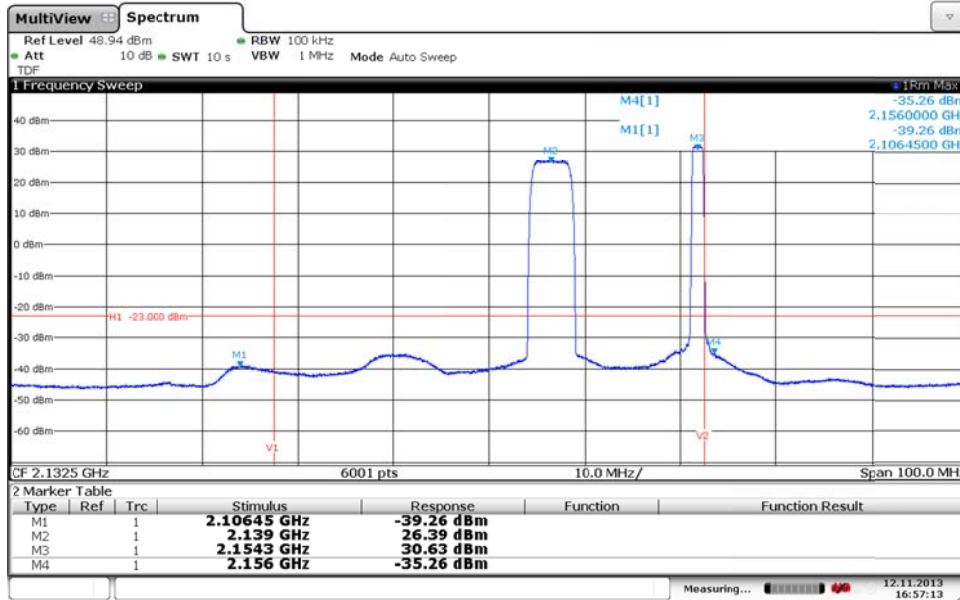

Date: 12 NOV.2013 16:57:13

Appendix 3

Diagram 7 c:

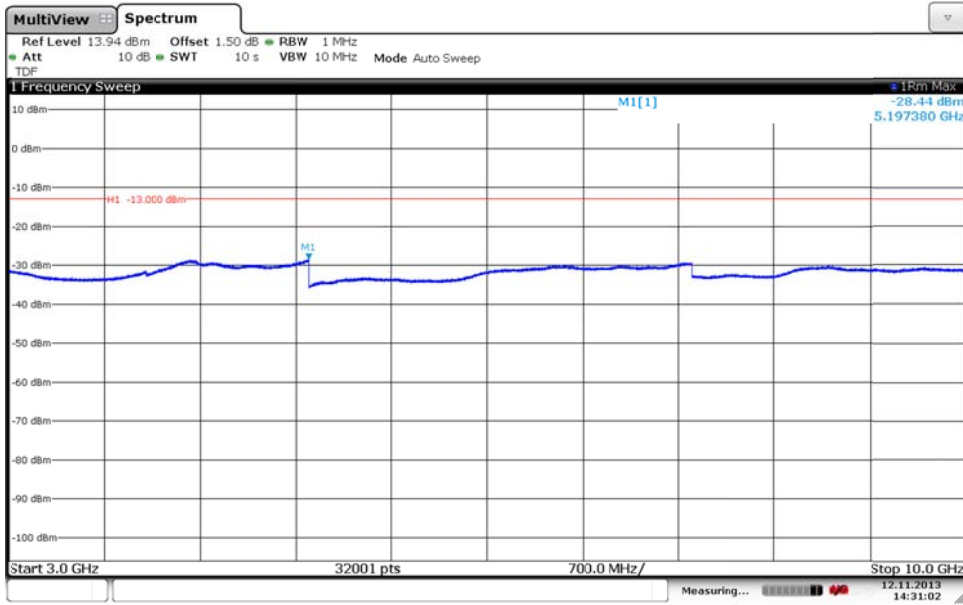

Date: 12 NOV. 2013 14:31:02

Diagram 7 d:

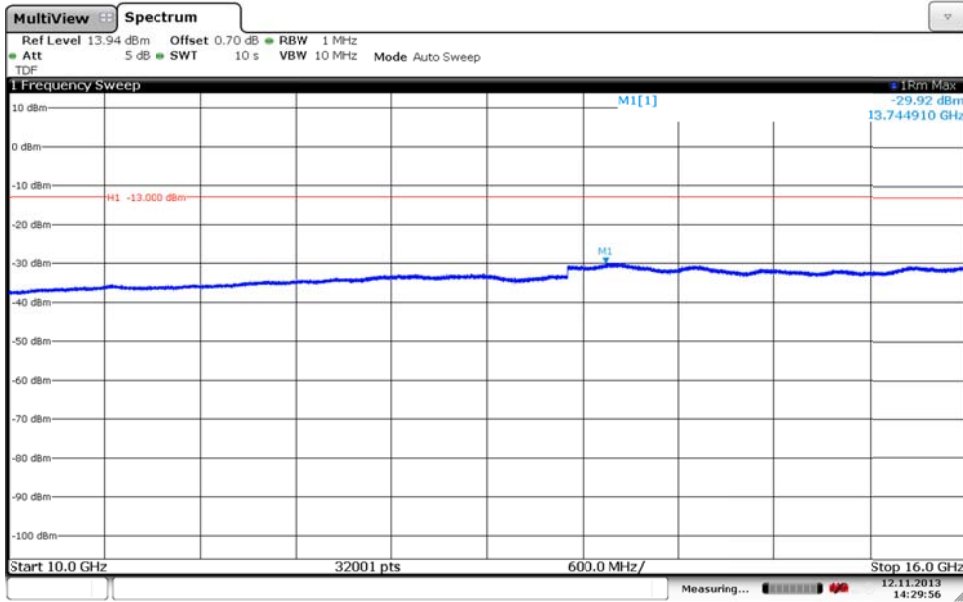

Date: 12 NOV. 2013 14:29:56

Appendix 3

Diagram 7 e:

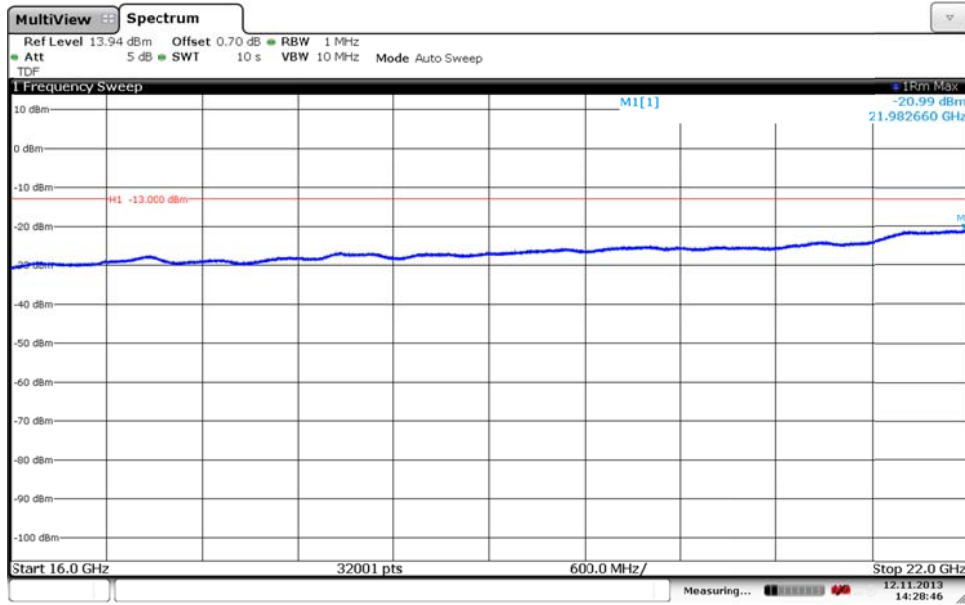

Date: 12 NOV. 2013 14:28:46

Appendix 4

Field strength of spurious radiation measurements according to 47 CFR 27.53 (h) / IC RSS-139 6.5

Date	Temperature	Humidity
2014-04-22	23°C ± 3°C	27 % ± 5 %

Test set-up and procedure

The test sites are listed at FCC, Columbia with registration number: 93866. The test site complies with RSS-Gen, Industry Canada file no. 3482A-1.

The measurements were performed with both horizontal and vertical polarization of the antenna. The antenna distance was 3 m in the frequency range 30 MHz – 18 GHz and 1m in the frequency range 18 - 22 GHz.

In the frequency range 30 MHz – 22 GHz the measurement was performed in power with a RBW of 1 MHz. A propagation loss in free space was calculated. The used formula was

$$\gamma = 20 \log \left(\frac{4\pi D}{\lambda} \right), \gamma \text{ is the propagation loss and } D \text{ is the antenna distance.}$$

The measurement procedure was as the following:

1. The pre-measurement was first performed with peak detector. The EUT was measured in eight directions and with the antenna at three heights, 1.0 m, 1.5 m and 2.0 m.
2. Spurious radiation on frequencies closer than 20 dB to the limit in the pre-measurement is scanned 0-360 degrees and the antenna is scanned 1- 4 m for maximum response. The emission is then measured with the RMS detector and the RMS value is reported. Frequencies closer than 10 dB to the limit when measured with the RMS detector were measured with the substitution method according to the standard.

Appendix 4

Representative test set-up during the spurious radiation measurements is shown in the picture below:

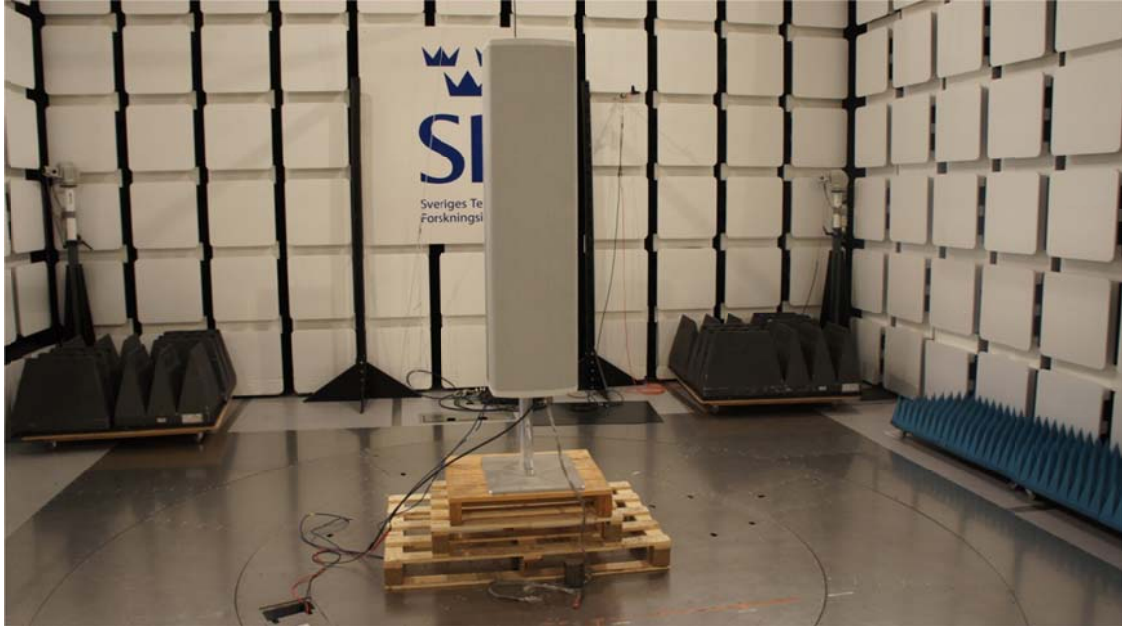

Measurement equipment

Measurement equipment	SP number
Semi anechoic chamber	503 881
R&S ESI 26	503 292
EMC 32 ver. 8.52.0	503 899
Chase Bilog Antenna CBL 6111A	502 182
EMCO Horn Antenna 3115	502 175
Flann STD Gain Horn Antenna 20240-20	503 674
High pass filter, RLC Electronics, 3-18 GHz	503 739
Miteq, Low Noise Amplifier	503 285
Schwartzbeck preamplifier BBV 9742	504 085
µComp Nordic, Low Noise Amplifier	901 545
Temperature and humidity meter, Testo 625	504 188

Tested configurations

Symbolic name
M1.4
M5

Appendix 4

Results, representing worst case

Diagram	Symbolic name
1 a-d	M1.4

Frequency (MHz)	Spurious emission level (dBm)	
	Vertical	Horizontal
30-22 000	All emission > 20 dB below limit	All emission > 20 dB below limit

Measurement uncertainty:

3.2 dB up to 18 GHz, 3.6 dB above 18 GHz

Limits

§27.53(h) and RSS-139 6.5

Outside a licensee's frequency band(s) of operation the power of any emission shall be attenuated below the transmitter power (P) by at least $43 + 10 \log (P)$ dB, resulting in a limit of -13 dBm per 1 MHz RBW.

Complies?	Yes
-----------	-----

Appendix 4

Diagram 1a:

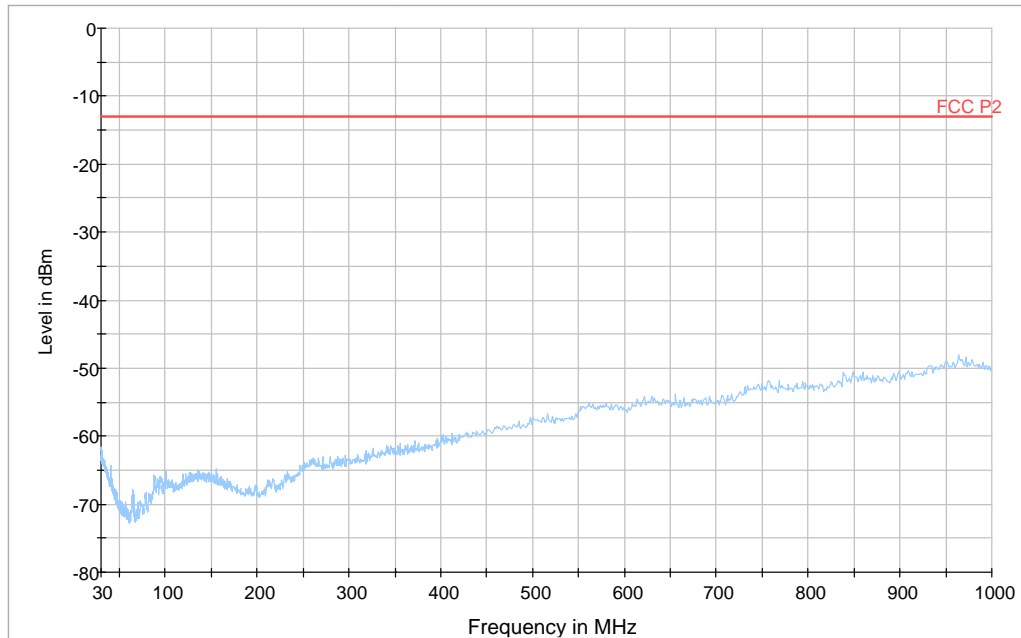
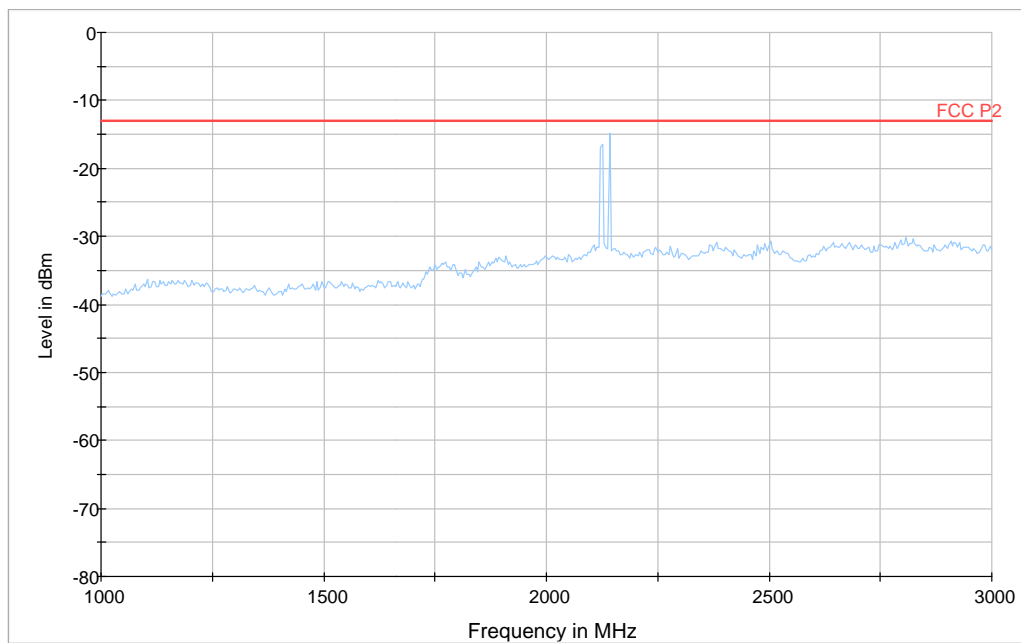

Diagram 1b:



Note: The emission between 2125 and 2141.8 MHz are the carrier frequencies and shall be ignored in the context.

Appendix 4

Diagram 1c:

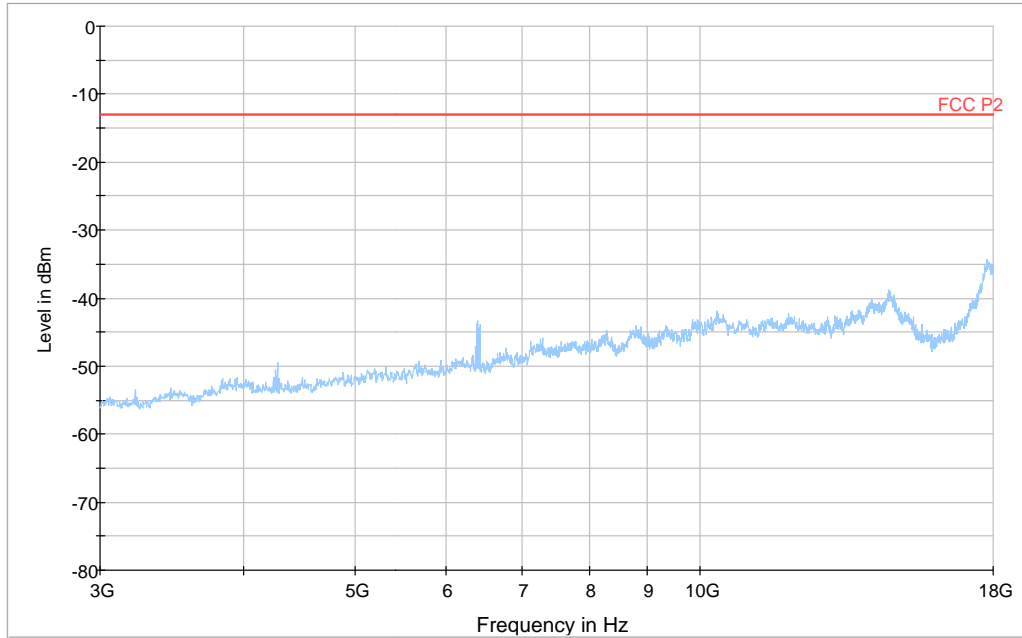
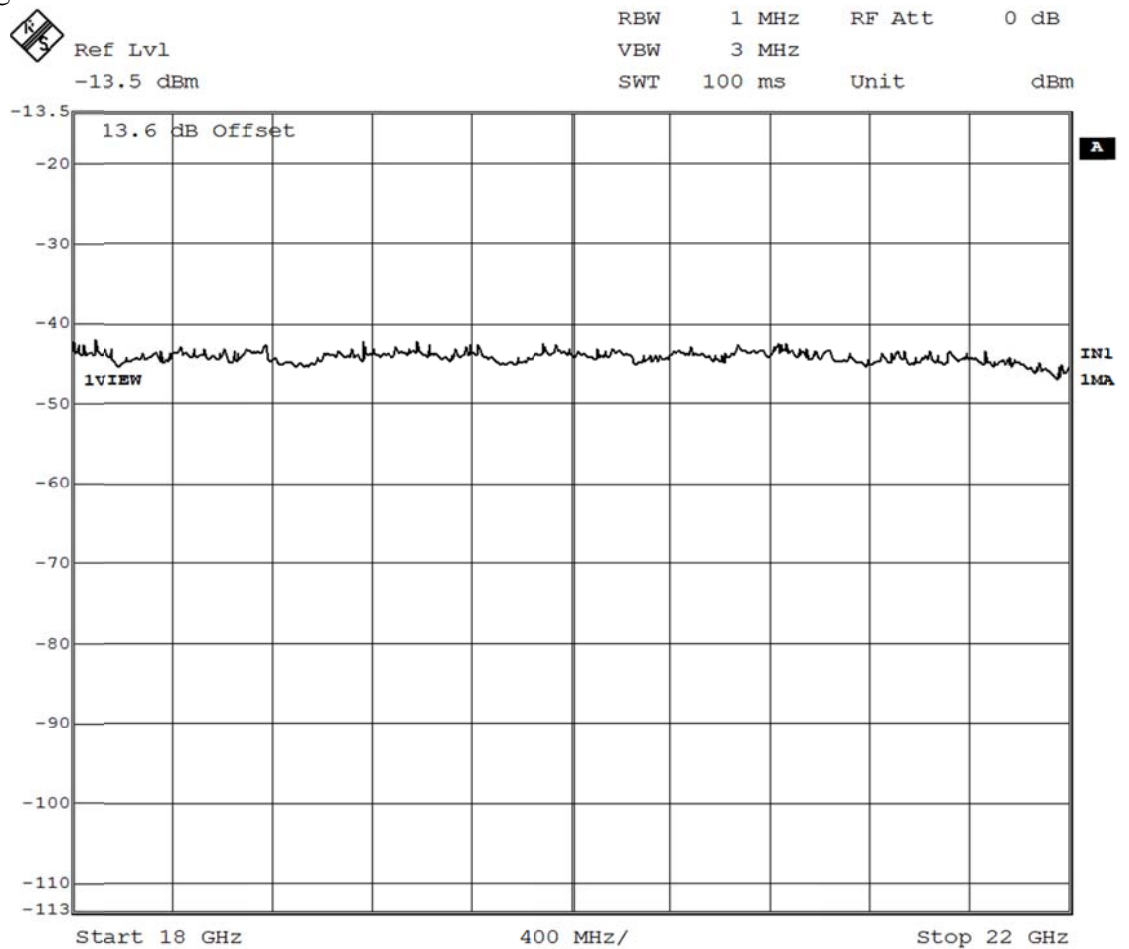

Diagram 1d:



Appendix 5

External photos

Front side



Rear side

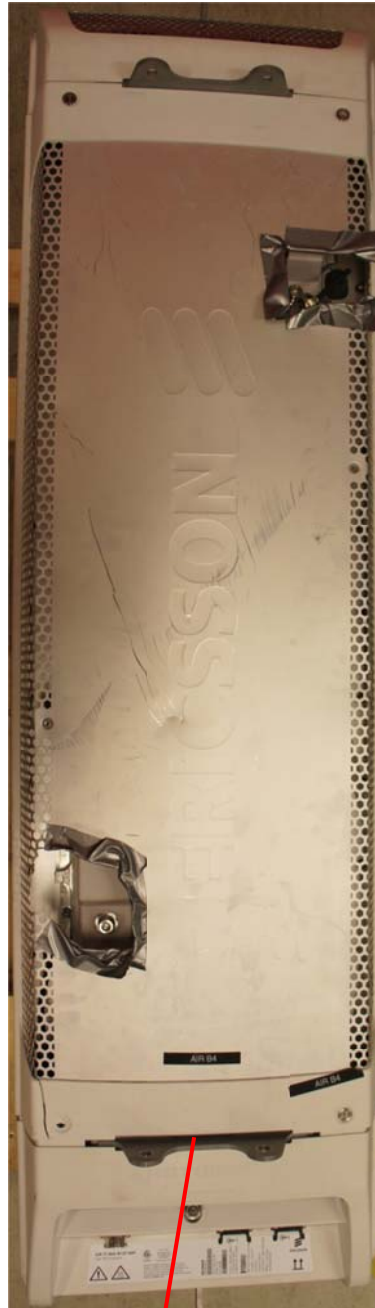

Appendix 5

Left side



Right side



Appendix 5

Top side



Bottom side

