

OPERATING INSTRUCTIONS

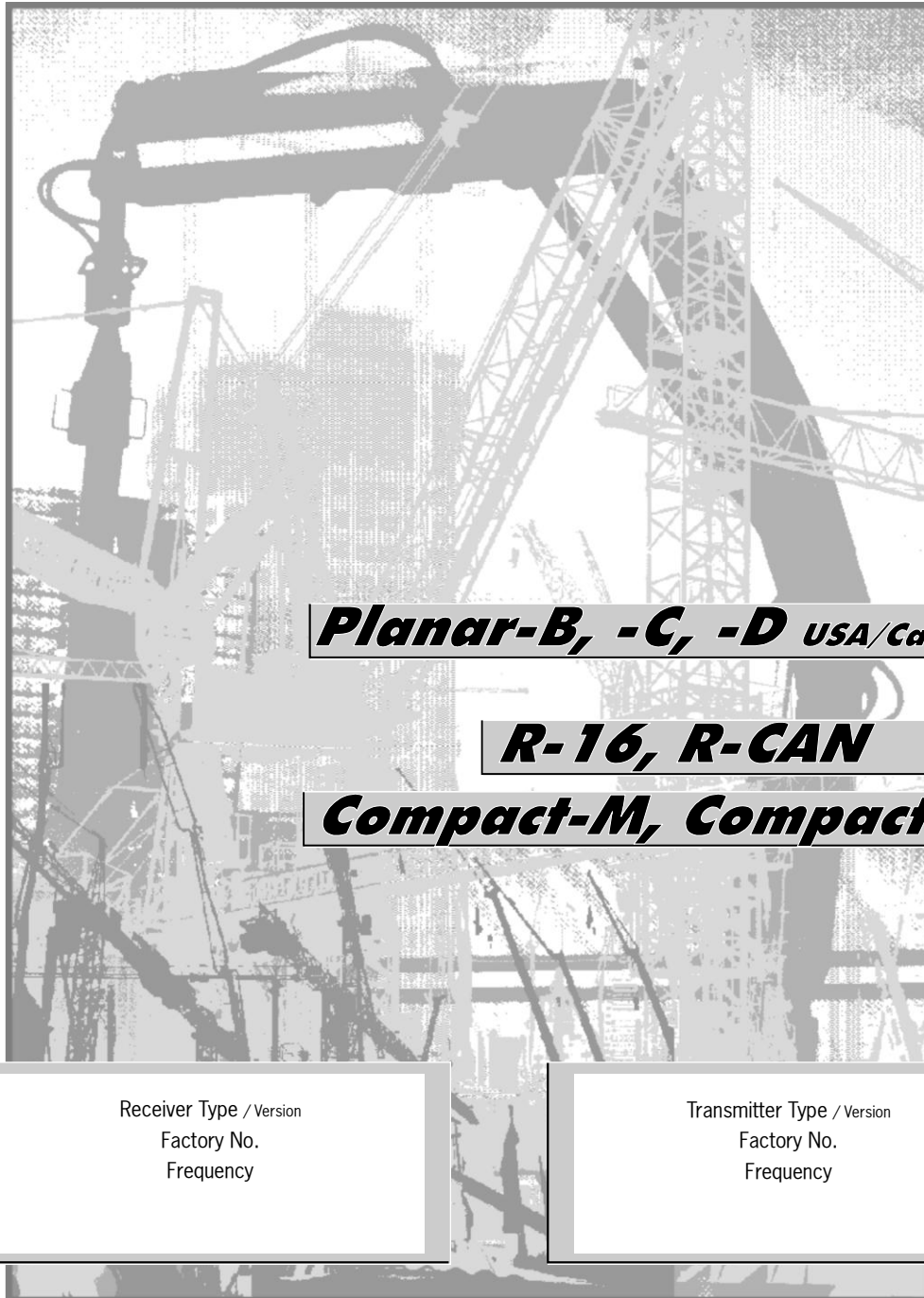

Planar-B, -C, -D USA/Canada

R-16, R-CAN

Compact-M, Compact-V

Receiver Type /Version
Factory No.
Frequency

Transmitter Type /Version
Factory No.
Frequency

1. STANDARD SPECIFICATION

- Portable transmitter.
- Receiver with integrated mounting holes.
- Multi-pin connecting cable for the receiver according to your specifications.

The actual delivery specification is as detailed on the confirmation of order or the delivery note accompanying the goods!

2. SAFETY PRECAUTIONS

Even if you are accustomed to working with radio control systems, read these operating instructions carefully before using this equipment. Only this document contains the latest information relating to your NBB radio control system.

For explanatory notes on obtaining an operating permit please refer to registration documents enclosed in the appendix of this operating instruction. Observe all applicable work-safety and accident prevention regulations carefully. Only fully trained, authorized personnel may use the NBB radio control equipment. Components, etc. built into the NBB equipment for safety purposes must be regularly inspected.



If the NBB radio control unit develops a fault, it must be shut down immediately. The transmitter should be switched off with the STOP key. The connecting cable must be disconnected at the receiver from the connecting socket (terminal) of the unit to be controlled. The repair of the equipment must not be carried out other than by NBB or an NBB authorized technician.

Failure to observe these recommendations will put both you yourself and others at risk. Under these circumstances, NBB rescinds the guarantee and any other form of liability. This radio control unit is designed exclusively for the control of construction machines and industrial plants. Only under these conditions are the safety systems (STOP and zero setting) fully effective. No other form of use is permitted. Any non-observance of this condition will relieve NBB of all liability.

3. TRANSMITTER

Switching on: To make the unit ready for use, unscrew the screw plug of the battery compartment on the back of the transmitter and remove the cover. Insert 2 charged AA Mignon batteries 1,2V NiMH (or batteries 1,5V - not rechargeable) into the battery compartment, close the cover and tighten the screw plug again.

Rechargeable batteries (NiMH or NiCd) must be fully charged before first use!
Never attempt to charge standard non rechargeable 1,5V AA batteries!

	Operation: The red dot flashes.
	Slowly flashing: Batteries are to low, to operate the transmitter.

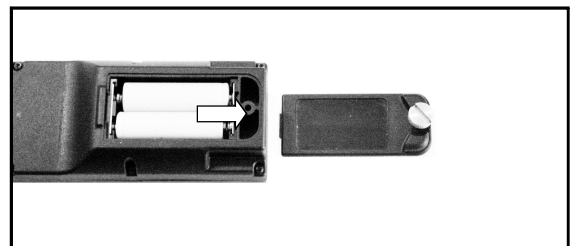
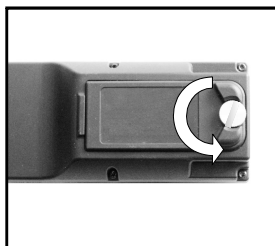

The functions of the receiver are released with the "ON/HORN" key.
The receiver has to be switched off with the "STOP" key when work is finished.
A red dot flashes on the Planar display during operation.

Energy saving function: The transmitter switches off automatically, if the keys are not pressed within a specified time. The red dot goes out.

Optional: Transmitter for continuous operation possible.

*The duration of this stand-by can be specified when ordering.



Operation:
The red dot flashes.



Quickly flashing:
Batteries are nearly empty.
Transmitter can be operated
for appr. 30 minutes more.

When the letter "L" flashes quickly on the Planar display, the batteries (rechargeable or not rechargeable) are nearly empty.

The transmitter can be operated for approximately 30 minutes more in this condition.

During this time, bring the unit to a safe position, switch off the transmitter and install 2 charged AA Mignon batteries 1,2V NiMH (or batteries 1,5V - not rechargeable).

Examples:

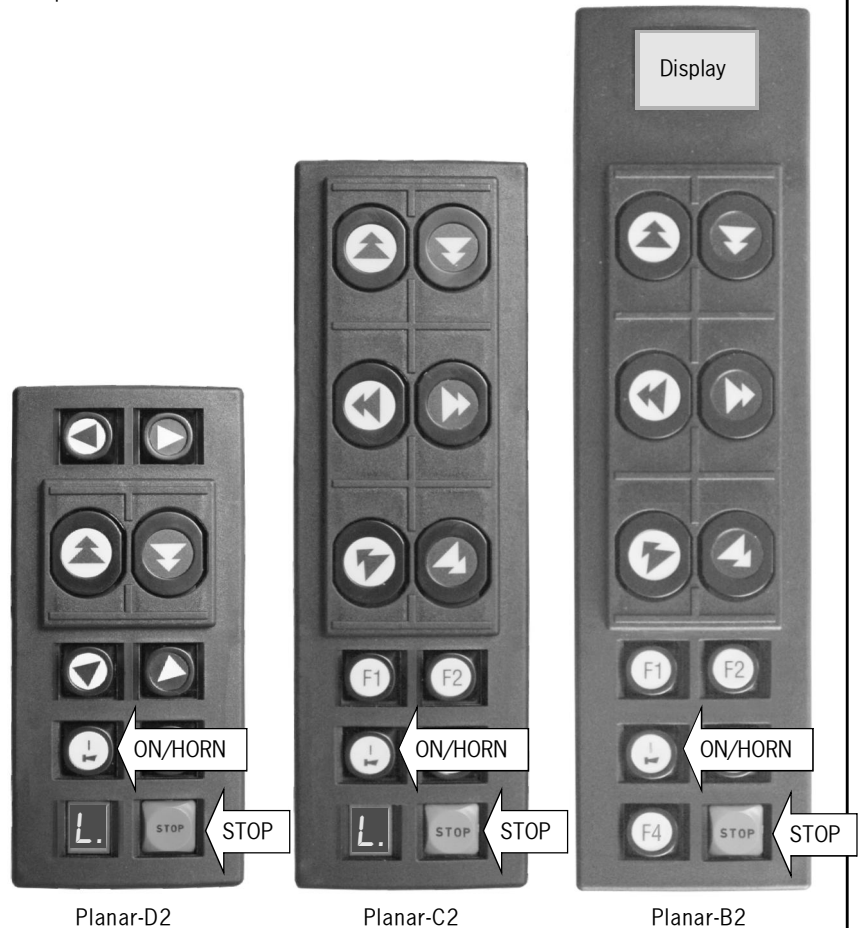

Available Planar-B, -C, -D upper housings:

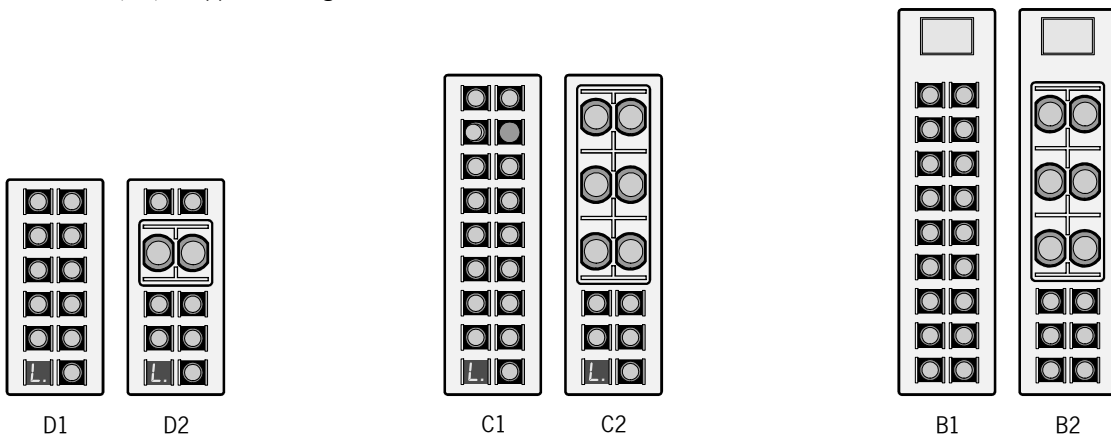

4. Base Unit for Planar-B, Planar-C and Planar-D

When a transmitter is operated with AA Mignon 1,2 V NiMH rechargeable batteries, these batteries automatically charge inside the transmitter in the optional base unit. To start the charging process simply slide the transmitter into base unit (see image 1). An automatically controlled charging process keeps batteries from over-charging. Base unit has to be connected to a power supply (optional also with dc-charger) – (see image 2).



WARNING: Never try to charge regular AA batteries (non-rechargeable batteries) – danger of explosion!



WARNING: Charge 8 hours (2000 mA/h) after total discharge of batteries or before first use.

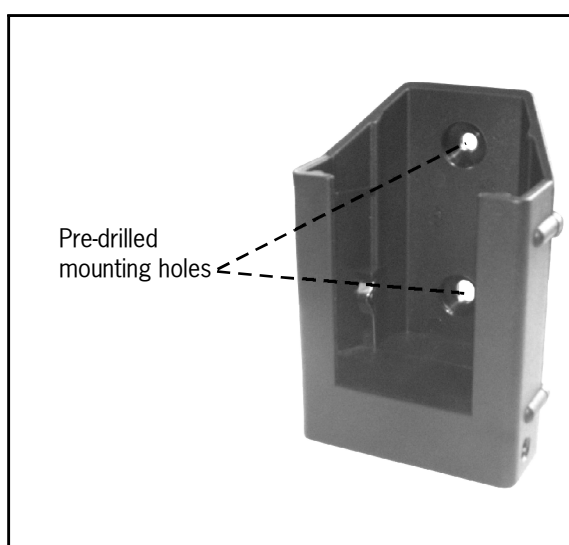
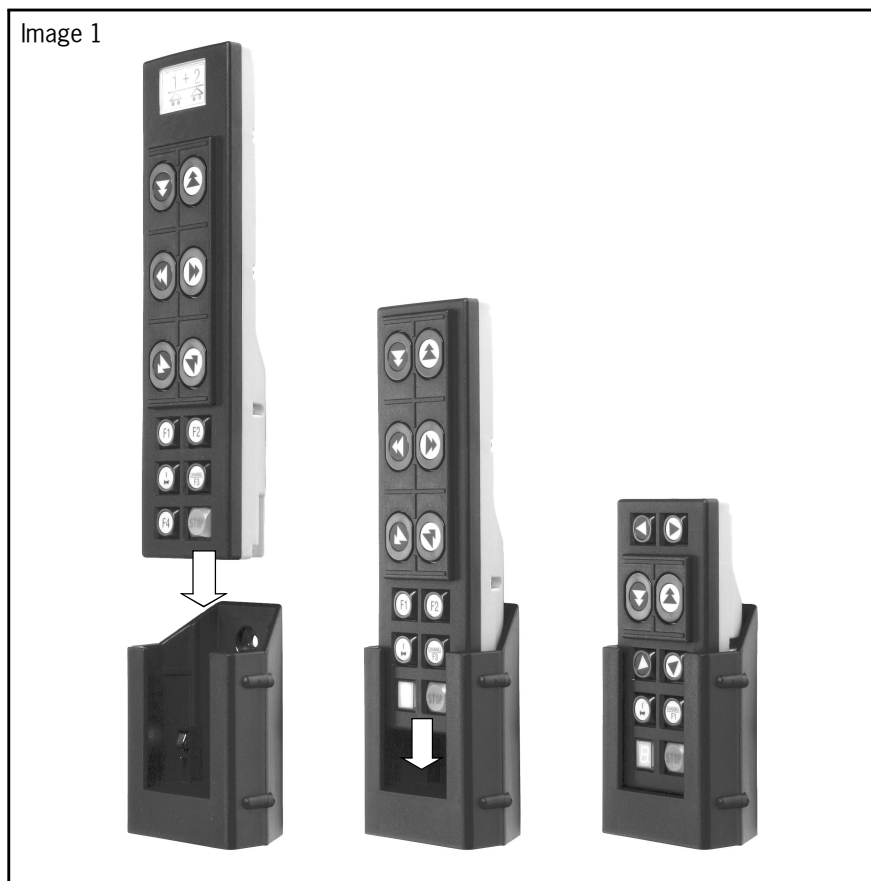

4. RECEIVER
 R-16, R-CAN
 Compact-M, Compact-V

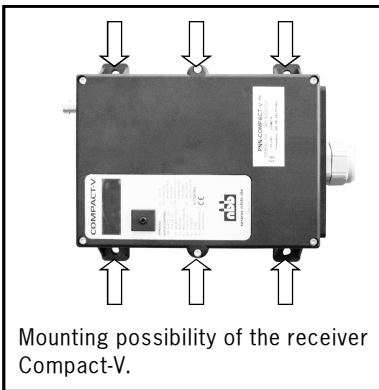
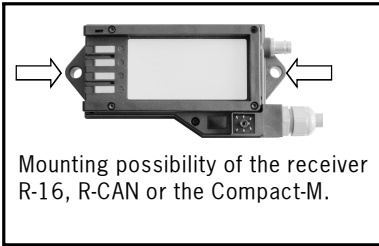
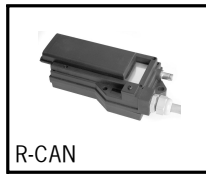

The receiver is connected to the unit to be controlled with the multi-pin connecting cable supplied. Please observe the instructions issued by the manufacturer of the unit to be controlled! We recommend urgently to realize this connection via a central, well accessible, multi-pin plug connector (for example HTS-plug connector series HE/HB/HN/HA or comparable ones of other manufacturers) to make possible a quick and clear fault diagnosis in the service case and to take off the receiver without an expenditure of assembly.

The power supply of the receiver is generally effected by the connecting cable.

- In general, an earth lead is required in case the units to be controlled have not previously been operated by radio control. Failing this, the receiver electronic circuit will not receive any power supply. Ensure that the operating voltage of the receiver complies with the electrical specifications of the unit to be controlled. The applicable operating voltage is specified in the supplement.
- Never expose the receiver to a high pressure cleaning jet. This applies to the transmitter also.
- The receiver should always be fixed vertically at the outside panel of the switching cabinet. (The antenna should always reach over the top of the panel.)
- You have to make sure that the antenna is not shielded by metal parts totally or partly.
- Mounting the receiver in a cabine or in a switching cabinet the antenna should be layed with an extension cable to the outside and be attached with the fastening strapping as horizontally as possible with distance to the shielding metal parts.
- In general the antenna should always be mounted in such a way so that the antenna is still visible with each change of position of the transmitter.

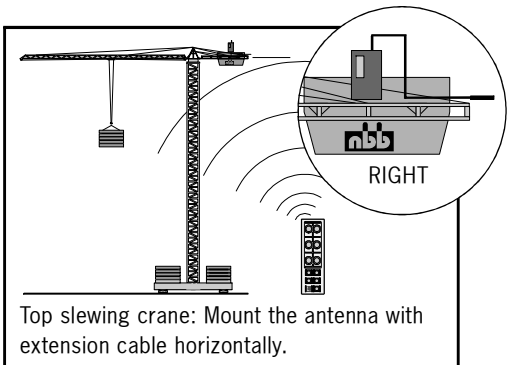
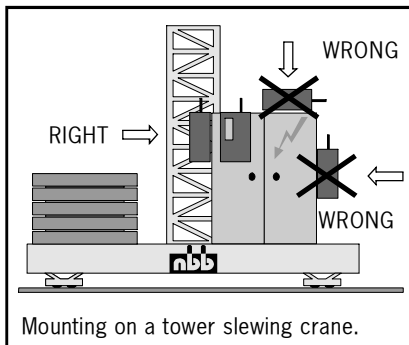

5. OPERATING THE UNIT

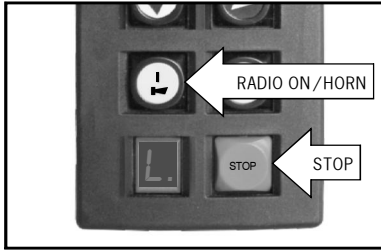

Safety equipment in the NBB-radio remote control:

In the transmitter, this comprises mainly:

- STOP (transmitter ON/OFF) with automatic disconnection of the power supply.
- Automatic zero positioning.

In the receiver:

- Automatic zero setting when switching back on after radio interruption.
- Locking of the radio commands at relay level in the event of a defective STOP circuit.

To ensure fault-free operation, please follow precisely the following rules for operation: The unit to be controlled can only be switched on - it is assumed that the transmitter is ready to operate - when no command unit is actuated. The command necessary to do so is triggered by the key "ON/HORN". This triggers a horn signal in the unit to be controlled. After switch-on of the facility to be controlled, this key is used for repeated emission of the horn signal in accordance with working regulations.

If the NBB radio remote control is not used for a long period, it is urgently recommended - if you use rechargeable batteries - that they should be charged now and again (about every 4 weeks). This prevents deep discharges of the batteries and prolongs their useful life. If you shut down the NBB radio remote control for a long period, we recommend you take the batteries out of the transmitter.

Frequency change Planar-B, -C, -D:

To change the frequency, keep the "ON/HORN" key pressed down. Then operate the "CHANNEL / FREQUENCY CHANGE" key. If the receiver locks into the new frequency, a horn signal is given (if present) and the unit to be controlled is ready for operation. Please observe the particular postal approval regulations of the concerned country.

Channel number: When changing the frequency the channel number lights up shortly in the display: First the decimal place, then the digit.

During operation the chosen channel can be shown by pressing the "CHANNEL / FREQUENCY CHANGE" key.

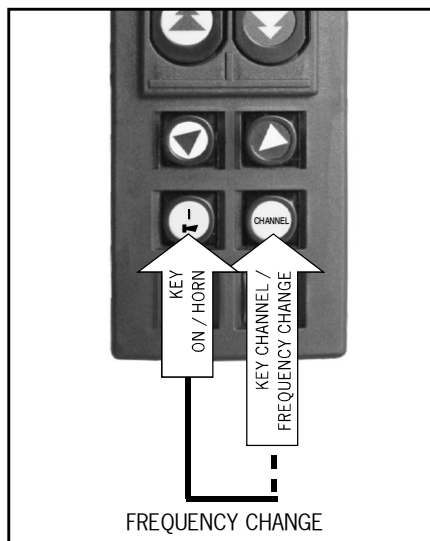

Channel number: f.e. Channel 53

5

First the decimal place is shown.

3.

Then the digit is shown.

6. FUNCTION CHECK

To maintain operational safety, a regular function check of the NBB radio remote control is necessary. In single-shift day-to-day operation, we recommend performing this check at least once a week. Checking is possible using the display lights provided on the receiver. To do so, the transmitter must be set to the ready-to-operate state.

- First connect just the receiver - the transmitter remains switched off.
- Activate the transmitter by pressing the key "START/ON/HORN" at the Planar transmitter.
- Now check the commands (always start with the lowest stage) and check for correct reaction of the unit to be controlled.
- Ensure in particular that there is nobody in the danger area.
ACCIDENT RISK!
- STOP check. Press the STOP key at the transmitter. Then observe if the unit to be controlled is switched off (time to switch off according to the application).

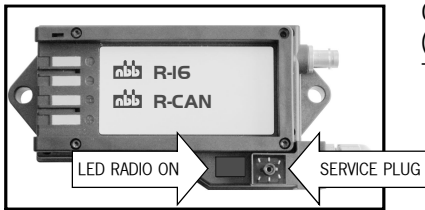

Checking the LED at the receiver R-16 and R-CAN:
(Optional with integrated charger)

- The Green LED flashes: RADIO PRESENT.
If the LED fails to come on:
1. Check that the transmitter is on.
 2. Check the power supply of the receiver.
 3. (Optional) Irregular flashing of the LED:
Check or change the current radio channel.

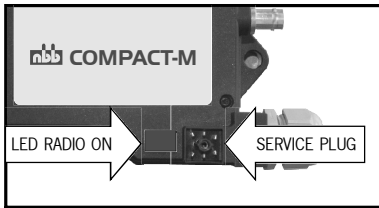

Checking the LED at the receiver Compact-M:
(Without charger)

- The Green LED flashes: RADIO PRESENT.
If the LED fails to come on:
1. Check that the transmitter is on.
 2. Check the power supply of the receiver.
 3. (Optional) Irregular flashing of the LED:
Check or change the current radio channel.

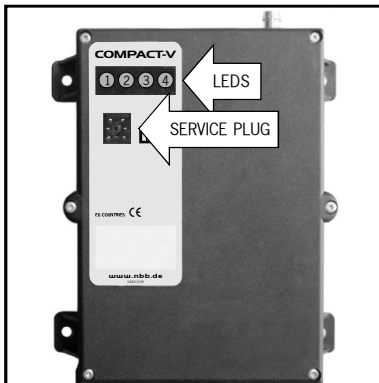

Checking the LED's at the receiver Compact-V:

- LED 1 green: POWER ON. If LED fails to come on, check the power supply. If the power lead is OK, call in the after-sales service.
- LED 2 yellow: HF PRESENT. Steady light when transmitter is switched on (insignificant for scanner operation).
- LED 3 green: Flashes evenly during fault-free operation. Irregular flashing means that the HF channel is probably at fault - please set another channel.
- LED 4 red: If this LED flashes, the HF channel is at fault (not for scanner operation). Steady light notifies the operator that an output function is critical due to high current.

Service plug: For NBB service only.

7. RATING PLATES

The rating plates state the type of transmitter or receiver, the factory number, the frequency range and the approval number for non EU countries.
Always state the factory number in all your queries.

Example:

Transmitter Type / Version: Planar-B (or C or D) Factory No.: 999 899 4990 Frequency: 915 -916.65 Mhz	Receiver Type / Version: Compact-V Factory No.: 999 899 4990 Frequency: 915 -916.65 Mhz
---	---

8. MAINTENANCE

Your NBB radio remote control is largely maintenance-free. Nevertheless, please bear in mind the following points:

- The STOP key must be easy to move.
- Remove any leftover building materials!
- During electro-welding work on the unit to be controlled, disconnect the receiver from the current supply! Otherwise there is a risk of damage to the receiver's electronic system!
- Check wear and tear parts like dust shield tops regular!

9. WARRANTY

We grant a function warranty for 12 months after the sale date for all NBB radio remote controls (transmitter, receiver, charger). The warranty covers working time and material used. Shipping costs shall be charged to the customer. The warranty shall not cover: wear and tear parts, relays and batteries. The function warranty shall be invalidated in the case of damage, accident damage, negligence, incorrect use, non-compliance with operating conditions, non-compliance with operating, testing and maintenance instructions, and repairs or unit modifications not authorised by NBB. NBB shall not be liable for indirect damage and reserves the right to decide on repair or replacement.

10. IN CASE OF DEFECTS

Do not attempt to continue working with a defective NBB radio remote control. Even initially minor defects might be the start of a more extensive defect.
Do not try to repair the NBB radio remote control yourself. If there is any fault please contact your dealer or our company.

11. US-FCC and CANADA IC



USA:

NOTE: This equipment has been tested and found to comply with the limits for a Class A digital device, pursuant to Part 15 of the FCC Rules. These limits are designed to provide reasonable protection against harmful interference when the equipment is operated in a commercial environment. This equipment generates, uses, and can radiate radio frequency energy and, if not installed and used in accordance with the instruction manual, may cause harmful interference to radio communications. Operation of this equipment in a residential area is likely to cause harmful interference in which case the user will be required to correct the interference at his own expense.



ATTENTION:

Changes or modifications not expressly approved by the manufacturer could void the user's authority to operate the equipment!

IC CANADA:



The installer of this radio equipment must ensure that the antenna is located or pointed such that it does not emit RF field in excess of Health Canada limits for the general population; consult Safety Code 6, obtainable from Health Canada's website www.hc-sc.gc.ca/rpb

This device complies with Industry Canada license-exempt RSS standard(s).

Operation is subject to the following two conditions:

- (1) this device may not cause interference, and
- (2) this device must accept any interference, including interference that may cause undesired operation of the device.

Cet appareil est conforme avec Industrie Canada exempt de licence Rss standard(s).

Son fonctionnement est soumis aux deux conditions suivantes :

- (1) cet appareil ne peut causer d'interférences, et
- (2) cet appareil doit accepter toute interférence, y compris des interférences qui peuvent provoquer un fonctionnement indésirable du périphérique.

Operating ambient temperature -20 to +70 °C
 Insulation class - Protection IP 65

TRANSMITTER Planar-B, Planar-C, Planar-D
 Transmission frequency range see product label

The use of synthesizer technology permits frequencies to be selected in accordance with the appropriate waveband for the country of use.

Low frequency modulation GFSK
 Data repetition rate about 15 ms / 60 ms
 Baud rate 1200 - 9600 Baud (Bit / sec.)
 Range about 100 m
 Power input about 60 mA
 RF output (Fieldstrength) < 50mV/m (3 Meter measuring distance acc. 47 CFR Part 15.249)

	Weight (without battery)	Size (L x W x H)
Planar-B	210 g	21,5 x 5,6 x 3,7 cm
Planar-C	205 g	18,0 x 5,6 x 3,7 cm
Planar-D	190 g	12,3 x 5,6 x 3,7 cm

Power supply 2 x rechargeable batteries 1,2V AA NiMH
 (or 2 x batteries 1,5V - not rechargeable)
 Operating duration >30h (2000mA/h NiMH batteries)

RECEIVER R-16, R-CAN, Compact-M, Compact-V

Reception frequency range see product label

Data security:
 Generates a CRC code with a Hamming distance = 4. Generates a neutral position.
 Addressing of each transmitter with its own, unique combination (max. 2¹⁶ possible combinations).

Security EMERGENCY STOP with self test.
 max. switching voltage 250V AC (12V / 24V DC - R-16, R-CAN, Compact-M, Compact-V)
 max. switching current 4A AC (3A DC at 12V / 24V - R-16, R-CAN, Compact-M, Compact-V)
 max. switching power 1000 VA

	Weight	Size (L x W x H)
R-16, R-CAN	640 g	18 x 9,7 x 4,4 cm
(potted)	800 g	
Compact-M	640 g	18 x 9 x 7 cm
(potted)	800 g	
Compact-V (potted)	1,5 kg	21,5 x 16 x 6,5 cm

APPROVALS AND CERTIFICATES



USA FCC ID: SJ7BCD915
CANADA IC: 2634B-BCD915

© NBB Controls + Components AG
Otto-Hahn-Straße 3-5
DE-75248 Ölbronn-Dürrn
Tel.: 0 72 37 / 9 99 - 0
Fax: 0 72 37 / 9 99 - 1 99
eMail: sales@nbb.de
<http://www.nbb.de>

We reserve the right to alter specifications without notice.



Bedienungsanleitung Planar-B, -C, -D, USA, Kanada, 915 Mhz,
englisch, Teile-Nr. 3.150.1340, Stand 06.09