

TEST REPORT

Report No.: 17080223HKG-001

Hong Kong Modern Marketing Manufacturing Limited

Application For Certification
(Original Grant)

FCC ID: S4WAUSCR66

Transceiver

PREPARED AND CHECKED BY:

APPROVED BY:

Signed On File
Leung Sung Tak, Andy
Engineer

Koo Wai Ip
Technical Supervisor
Date: November 20, 2017

Intertek's standard Terms and Conditions can be obtained at our website <http://www.intertek.com/terms/>.

The test report only allows to be revised within the retention period unless further standard or the requirement was noticed

This report is for the exclusive use of Intertek's Client and is provided pursuant to the agreement between Intertek and its Client. Intertek's responsibility and liability are limited to the terms and conditions of the agreement. Intertek assumes no liability to any party, other than to the Client in accordance with the agreement, for any loss, expense or damage occasioned by the use of this report. Only the Client is authorized to permit copying or distribution of this report and then only in its entirety. Any use of the Intertek name or one of its marks for the sale or advertisement of the tested material, product or service must first be approved in writing by Intertek. The observations and test results in this report are relevant only to the sample tested. This report by itself does not imply that the material, product, or service is or has ever been under an Intertek certification program.

© 2017 Intertek

TEST REPORT**GENERAL INFORMATION**

Grantee:	Hong Kong Modern Marketing Manufacturing Limited
Grantee Address:	Unit A, 10/F., Capital Commercial Building, No. 446-448 Shanghai Street, Mongkok, Kowloon, Hong Kong.
Contact Person:	Andy Leung
Tel:	852 2736 0201
Fax:	852 2736 0201
e-mail:	andyleung@daklin.com
Manufacturer:	Modern Marketing Manufacturing Limited
Manufacturer Address:	Ha Bin Industrial District, Lai Lu Shan Chong, Hau Kai, Dongguan, China.
Brand Name:	Crosley
Model:	CR66D
Type of EUT:	Transceiver
Description of EUT:	Rochester Entertainment Center With Bluetooth
Serial Number:	N/A
FCC ID:	S4WAUSCR66
Date of Sample Submitted:	August 03, 2017
Date of Test:	August 03, 2017 to October 18, 2017
Report No.:	17080223HKG-001
Report Date:	November 20, 2017
Environmental Conditions:	Temperature: +10 to 40°C Humidity: 10 to 90%

TEST REPORT

SUMMARY OF TEST RESULT

TEST SPECIFICATION	REFERENCE	RESULTS
Transmitter Power Line Conducted Emissions	15.207	Pass
Radiated Emission Radiated Emission on the Bandedge	15.249, 15.209	Pass
Radiated Emission in Restricted Bands	15.205	Pass

The equipment under test is found to be complying with the following standards:

FCC Part 15, October 1, 2016 Edition

- Note:
1. The EUT uses a permanently attached antenna which, in accordance to section 15.203, is considered sufficient to comply with the provisions of this section.
 2. Pursuant to FCC part 15 Section 15.215(c), the 20 dB bandwidth of the emission was contained within the frequency band designated (mentioned as above) which the EUT operated. The effects, if any, from frequency sweeping, frequency hopping, other modulation techniques and frequency stability over expected variations in temperature and supply voltage were considered.

TEST REPORT

TABLE OF CONTENTS

1.0	GENERAL DESCRIPTION	5
1.1	Product Description	5
1.2	Related Submittal(s) Grants	5
1.3	Test Methodology	5
1.4	Test Facility	5
2.0	SYSTEM TEST CONFIGURATION	6
2.1	Justification	6
2.2	EUT Exercising Software	6
2.3	Special Accessories	6
2.4	Measurement Uncertainty	6
2.5	Support Equipment List and Description	6
3.0	EMISSION RESULTS	7
3.1	Field Strength Calculation	7
3.2	Radiated Emission Configuration Photograph	8
3.3	Radiated Emission Data	8
3.4	Conducted Emission Configuration Photograph	8
3.5	Conducted Emission Data	8
4.0	EQUIPMENT PHOTOGRAPHS	14
5.0	PRODUCT LABELLING	14
6.0	TECHNICAL SPECIFICATIONS	14
7.0	INSTRUCTION MANUAL	14
8.0	MISCELLANEOUS INFORMATION	15
8.1	Radiated Emission on the Bandedge	15
8.2	Discussion of Pulse Desensitization	18
8.3	Calculation of Average Factor	18
8.4	Emissions Test Procedures	19
9.0	CONFIDENTIALITY REQUEST	23
10.0	EQUIPMENT LIST	23

TEST REPORT

1.0 GENERAL DESCRIPTION

1.1 Product Description

The Equipment Under Test (EUT) is a CD Audio System that can accept audio sources including CD, AM/FM Tuner, analog line-in, tape, phono and Bluetooth devices. The Bluetooth 3.0 module in the EUT is operating in the frequency range from 2402MHz to 2480MHz (79 channels with 1MHz channel spacing). The audio signal is amplified and fed to the supplied passive external stereo loudspeakers. The EUT is powered by 120VAC.

Antenna Type: Internal, Integral

For electronic filing, the brief circuit description is saved with filename: descri.pdf.

1.2 Related Submittal(s) Grants

This is a single application for certification of a transceiver.

1.3 Test Methodology

Radiated emission measurements were performed according to the procedures in ANSI C63.10 (2013). All radiated measurements were performed in an 3m Chamber. Preliminary scans were performed in the 3m Chamber only to determine worst case modes. All radiated tests were performed at an antenna to EUT distance of 3 meters, unless stated otherwise in the “**Justification Section**” of this Application.

1.4 Test Facility

The 3m Chamber used to collect the radiated data is located at Workshop No. 3, G/F., World-Wide Industrial Centre, 43-47 Shan Mei Street, Fo Tan, Sha Tin, N.T., Hong Kong. This test facility and site measurement data have been placed on file with the FCC.

TEST REPORT

2.0 SYSTEM TEST CONFIGURATION

2.1 Justification

The system was configured for testing in a typical fashion (as a customer would normally use it), and in the confines as outlined in ANSI C63.10 (2013).

The device was powered by 110VAC 50/60Hz.

For maximizing emissions, the EUT was rotated through 360°, the antenna height was varied from 1 meter to 4 meters above the ground plane, and the antenna polarization was changed. This step by step procedure for maximizing emissions led to the data reported in Exhibit 3.0.

The unit was operated standalone and placed in the center of the turntable.

The equipment under test (EUT) was configured for testing in a typical fashion (as a customer would normally use it). The EUT was mounted to a plastic stand if necessary and placed on the wooden turntable, which enabled the engineer to maximize emissions through its placement in the three orthogonal axes.

2.2 EUT Exercising Software

There was no special software to exercise the device. Once the unit is powered up, it transmits the RF signal continuously.

2.3 Special Accessories

There are no special accessories necessary for compliance of this product.

2.4 Measurement Uncertainty

When determining of the test conclusion, the Measurement Uncertainty of test has been considered.

2.5 Support Equipment List and Description

N/A.

TEST REPORT

3.0 EMISSION RESULTS

Data is included of the worst case configuration (the configuration which resulted in the highest emission levels). A sample calculation, configuration photographs and data tables of the emissions are included.

3.1 Field Strength Calculation

The field strength is calculated by adding the Antenna Factor and Cable Factor, and subtracting the Amplifier Gain (if any), Average Factor (optional) from the measured reading. The basic equation with a sample calculation is as follows:

$$FS = RA + AF + CF - AG - AV$$

where FS = Field Strength in dB μ V/m

RA = Receiver Amplitude (including preamplifier) in dB μ V

CF = Cable Attenuation Factor in dB

AF = Antenna Factor in dB

AG = Amplifier Gain in dB

AV = Average Factor in dB

In the following table(s), the reading shown on the data table reflects the preamplifier gain. An example for the calculations in the following table is as follows:

$$FS = RR + LF$$

where

FS = Field Strength in dB μ V/m

RR = RA - AG - AV in dB μ V

LF = CF + AF in dB

Assume a receiver reading of 52.0 dB μ V is obtained. The antenna factor of 7.4 dB and cable factor of 1.6 dB are added. The amplifier gain of 29 dB and average factor of 5 dB are subtracted, giving a field strength of 32 dB μ V/m. This value in dB μ V/m was converted to its corresponding level in μ V/m.

$$RA = 52.0 \text{ dB}\mu\text{V/m}$$

$$AF = 7.4 \text{ dB}$$

$$CF = 1.6 \text{ dB}$$

$$AG = 29.0 \text{ dB}$$

$$AV = 5.0 \text{ dB}$$

$$FS = RR + LF$$

$$FS = 18 + 9 = 27 \text{ dB}\mu\text{V/m}$$

$$RR = 18.0 \text{ dB}\mu\text{V}$$

$$LF = 9.0 \text{ dB}$$

$$\text{Level in } \mu\text{V/m} = \text{Common Antilogarithm} [(27 \text{ dB}\mu\text{V/m})/20] = 22.4 \mu\text{V/m}$$

TEST REPORT

3.2 Radiated Emission Configuration Photograph

The worst case in radiated emission was found at 31.360 MHz

For electronic filing, the worst case radiated emission configuration photographs are saved with filename: radiated photos.pdf.

3.3 Radiated Emission Data

The data on the following page lists the significant emission frequencies, the limit and the margin of compliance. Numbers with a minus sign are below the limit.

Judgment: Passed by 9.6 dB

3.4 Conducted Emission Configuration Photograph

For electronic filing, the worst case line-conducted configuration photographs are saved with filename: conducted photo.pdf.

3.5 Conducted Emission Data

For electronic filing, the graph and data table of conducted emission is saved with filename: conducted.pdf.

Judgment: Pass by >20 dB

TEST REPORT

CONDUCTED EMISSION

Model: CR66D

Date of Test: November 20, 2017

Worst-Case Operating Mode: Bluetooth Playing

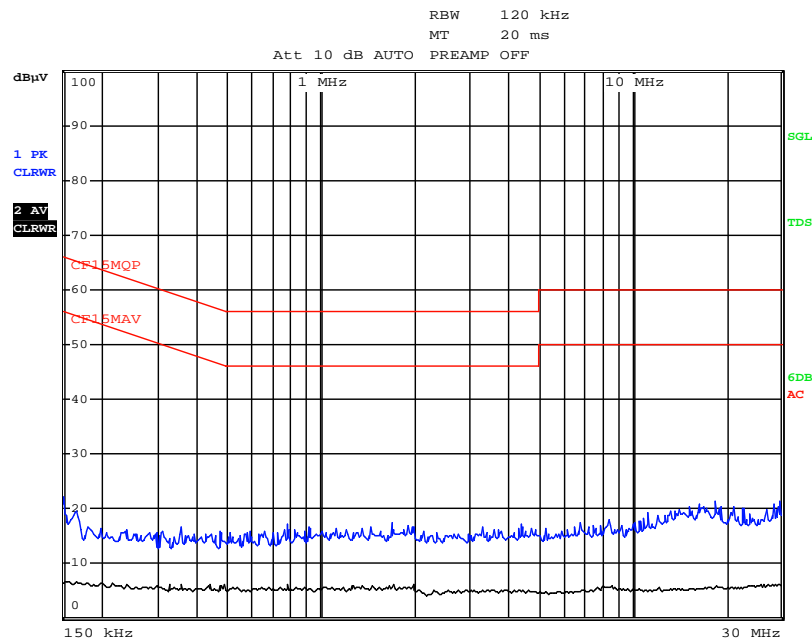

Note: Measurement Uncertainty is ± 4.2 dB at a level of confidence of 95%.

TEST REPORT

RADIATED EMISSIONS

Model: CR66D

Date of Test: October 18, 2017

Worst-Case Operating Mode: Transmitting

Table 1
Pursuant to FCC Part 15 Section 15.249 Requirement

Lowest Channel

Polarization	Frequency (MHz)	Reading (dB μ V)	Pre-Amp Gain (dB)	Antenna Factor (dB)	Net at 3m - Peak (dB μ V/m)	Average Factor (dB)	Calculated at 3m (dB μ V/m)	Average Limit at 3m (dB μ V/m)	Margin (dB)
H	2402.000	94.4	33	29.4	90.8	24	66.8	94.0	-27.2
V	4804.000	44.9	33	34.9	46.8	24	22.8	54.0	-31.2
V	7206.000	39.6	33	37.9	44.5	24	20.5	54.0	-33.5
V	9608.000	39.7	33	40.4	47.1	24	23.1	54.0	-30.9
H	12010.000	43.2	33	40.5	50.7	24	26.7	54.0	-27.3
H	14412.000	45.1	33	40.0	52.1	24	28.1	54.0	-25.9

Polarization	Frequency (MHz)	Reading (dB μ V)	Pre-Amp Gain (dB)	Antenna Factor (dB)	Net at 3m - Peak (dB μ V/m)	Peak Limit at 3m (dB μ V/m)	Margin (dB)
H	2402.000	94.4	33	29.4	90.8	114.0	-23.2
V	4804.000	44.9	33	34.9	46.8	74.0	-27.2
V	7206.000	39.6	33	37.9	44.5	74.0	-29.5
V	9608.000	39.7	33	40.4	47.1	74.0	-26.9
H	12010.000	43.2	33	40.5	50.7	74.0	-23.3
H	14412.000	45.1	33	40.0	52.1	74.0	-21.9

- NOTES:
1. Peak Detector Data unless otherwise stated.
 2. All measurements were made at 3 meters. Harmonic emissions not detected at the 3-meter distances were measured at 0.3-meter and an inverse proportional extrapolation was performed to compare the signal level to the 3-meter limit. No other harmonic emissions than those reported were detected at a test distance of 0.3-meter.
 3. Negative sign in the column shows value below limit.
 4. Horn antenna is used for the emission over 1000MHz.
 5. Emission (the row indicated by **bold italic**) within the restricted band meets the requirement of FCC Part 15 Section 15.205.
 6. Measurement Uncertainty is ± 5.3 dB at a level of confidence of 95%.

TEST REPORT

Model: CR66D

Date of Test: October 18, 2017

Worst-Case Operating Mode: Transmitting

Table 2
Pursuant to FCC Part 15 Section 15.249 Requirement

Middle Channel

Polarization	Frequency (MHz)	Reading (dBμV)	Pre-Amp Gain (dB)	Antenna Factor (dB)	Net at 3m - Peak (dBμV/m)	Average Factor (dB)	Calculated at 3m (dBμV/m)	Average Limit at 3m (dBμV/m)	Margin (dB)
V	2442.000	94.0	33	29.4	90.4	24	66.4	94.0	-27.6
H	4884.000	44.2	33	34.9	46.1	24	22.1	54.0	-31.9
H	7326.000	39.9	33	37.9	44.8	24	20.8	54.0	-33.2
V	9768.000	40.5	33	40.4	47.9	24	23.9	54.0	-30.1
H	12210.000	43.2	33	40.5	50.7	24	26.7	54.0	-27.3
V	14652.000	46.6	33	38.4	52.0	24	28.0	54.0	-26.0

Polarization	Frequency (MHz)	Reading (dBμV)	Pre-Amp Gain (dB)	Antenna Factor (dB)	Net at 3m - Peak (dBμV/m)	Peak Limit at 3m (dBμV/m)	Margin (dB)
V	2442.000	94.0	33	29.4	90.4	114.0	-23.6
H	4884.000	44.2	33	34.9	46.1	74.0	-27.9
H	7326.000	39.9	33	37.9	44.8	74.0	-29.2
V	9768.000	40.5	33	40.4	47.9	74.0	-26.1
H	12210.000	43.2	33	40.5	50.7	74.0	-23.3
V	14652.000	46.6	33	38.4	52.0	74.0	-22.0

- NOTES:
1. Peak Detector Data unless otherwise stated.
 2. All measurements were made at 3 meters. Harmonic emissions not detected at the 3-meter distances were measured at 0.3-meter and an inverse proportional extrapolation was performed to compare the signal level to the 3-meter limit. No other harmonic emissions than those reported were detected at a test distance of 0.3-meter.
 3. Negative sign in the column shows value below limit.
 4. Horn antenna is used for the emission over 1000MHz.
 5. Emission (the row indicated by **bold italic**) within the restricted band meets the requirement of FCC Part 15 Section 15.205.
 6. Measurement Uncertainty is ±5.3dB at a level of confidence of 95%.

TEST REPORT

Model: CR66D

Date of Test: October 18, 2017

Worst-Case Operating Mode: Transmitting

Table 3
Pursuant to FCC Part 15 Section 15.249 Requirement

Highest Channel

Polarization	Frequency (MHz)	Reading (dBμV)	Pre-Amp Gain (dB)	Antenna Factor (dB)	Net at 3m - Peak (dBμV/m)	Average Factor (dB)	Calculated at 3m (dBμV/m)	Average Limit at 3m (dBμV/m)	Margin (dB)
H	2480.000	94.7	33	29.4	91.1	24	67.1	94.0	-26.9
H	4960.000	46.6	33	34.9	48.5	24	24.5	54.0	-29.5
H	7440.000	39.9	33	37.9	44.8	24	20.8	54.0	-33.2
H	9920.000	39.9	33	40.4	47.3	24	23.3	54.0	-30.7
V	12400.000	42.8	33	40.5	50.3	24	26.3	54.0	-27.7
H	14880.000	46.9	33	38.4	52.3	24	28.3	54.0	-25.7

Polarization	Frequency (MHz)	Reading (dBμV)	Pre-Amp Gain (dB)	Antenna Factor (dB)	Net at 3m - Peak (dBμV/m)	Peak Limit at 3m (dBμV/m)	Margin (dB)
H	2480.000	94.7	33	29.4	91.1	114.0	-22.9
H	4960.000	46.6	33	34.9	48.5	74.0	-25.5
H	7440.000	39.9	33	37.9	44.8	74.0	-29.2
H	9920.000	39.9	33	40.4	47.3	74.0	-26.7
V	12400.000	42.8	33	40.5	50.3	74.0	-23.7
H	14880.000	46.9	33	38.4	52.3	74.0	-21.7

- NOTES:
1. Peak Detector Data unless otherwise stated.
 2. All measurements were made at 3 meters. Harmonic emissions not detected at the 3-meter distances were measured at 0.3-meter and an inverse proportional extrapolation was performed to compare the signal level to the 3-meter limit. No other harmonic emissions than those reported were detected at a test distance of 0.3-meter.
 3. Negative sign in the column shows value below limit.
 4. Horn antenna is used for the emission over 1000MHz.
 5. Emission (the row indicated by **bold italic**) within the restricted band meets the requirement of FCC Part 15 Section 15.205.
 6. Measurement Uncertainty is ±5.3dB at a level of confidence of 95%.

TEST REPORT

Model: CR66D

Date of Test: October 18, 2017

Worst-Case Operating Mode: Bluetooth Play

Table 4
Pursuant to FCC Part 15 Section 15.109 Requirement

Polarization	Frequency (MHz)	Reading (dBμV)	Pre-amp (dB)	Antenna Factor (dB)	Net at 3m (dBμV/m)	Limit at 3m (dBμV/m)	Margin (dB)
V	31.360	36.4	16	10.0	30.4	40.0	-9.6
V	95.960	24.3	16	12.0	20.3	43.5	-23.2
V	112.960	29.7	16	14.0	27.7	43.5	-15.8
H	156.140	20.2	16	16.0	20.2	43.5	-23.3
V	208.000	23.3	16	17.0	24.3	43.5	-19.2
H	276.000	18.9	16	22.0	24.9	46.0	-21.1
H	286.000	19.4	16	22.0	25.4	46.0	-20.6
H	324.000	18.8	16	24.0	26.8	46.0	-19.2
H	372.000	16.2	16	24.0	24.2	46.0	-21.8
V	444.000	12.3	16	26.0	22.3	46.0	-23.7
H	780.000	11.0	16	31.0	26.0	46.0	-20.0
H	876.000	12.8	16	32.0	28.8	46.0	-17.2

- NOTES:
1. Peak Detector Data unless otherwise stated.
 2. All measurements were made at 3 meters. Harmonic emissions not detected at the 3-meter distances were measured at 0.3-meter and an inverse proportional extrapolation was performed to compare the signal level to the 3-meter limit. No other harmonic emissions than those reported were detected at a test distance of 0.3-meter.
 3. Negative sign in the column shows value below limit.
 4. Horn antenna is used for the emission over 1000MHz.
 5. Emission (the row indicated by **bold italic**) within the restricted band meets the requirement of FCC Part 15 Section 15.205.
 6. Measurement Uncertainty is ±5.3dB at a level of confidence of 95%.

TEST REPORT**4.0 EQUIPMENT PHOTOGRAPHS**

For electronic filing, the photographs are saved with filename: external photos.pdf and internal photos.pdf.

5.0 PRODUCT LABELLING

For electronics filing, the FCC ID label artwork and the label location are saved with filename: label.pdf.

6.0 TECHNICAL SPECIFICATIONS

For electronic filing, the block diagram and schematic of the tested EUT are saved with filename: block.pdf and circuit.pdf respectively.

7.0 INSTRUCTION MANUAL

For electronic filing, a preliminary copy of the Instruction Manual is saved with filename: manual.pdf.

This manual will be provided to the end-user with each unit sold/leased in the United States.

TEST REPORT

8.0 MISCELLANEOUS INFORMATION

The miscellaneous information includes details of the test procedure and measured bandwidth / calculation of factor such as pulse desensitization and averaging factor (calculation and timing diagram).

8.1 Radiated Emission on the Bandedge

From the following plots, they show that the fundamental emissions are confined in the specified band (2400MHz to 2483.5MHz). In case of the fundamental emissions are within two standard bandwidths from the bandedge, the delta measurement technique is used for determining bandedge compliance. Standard bandwidth is the bandwidth specified by ANSI C63.10 (2013) for frequency being measured.

Emissions radiated outside of the specified frequency bands, except harmonics, are attenuated by 50dB below the level of the fundamental or to the general radiated emissions limits in Section 15.209, whichever is the lesser attenuation, which meet the requirement of part 15.249(d).

TEST REPORT

Peak Measurement

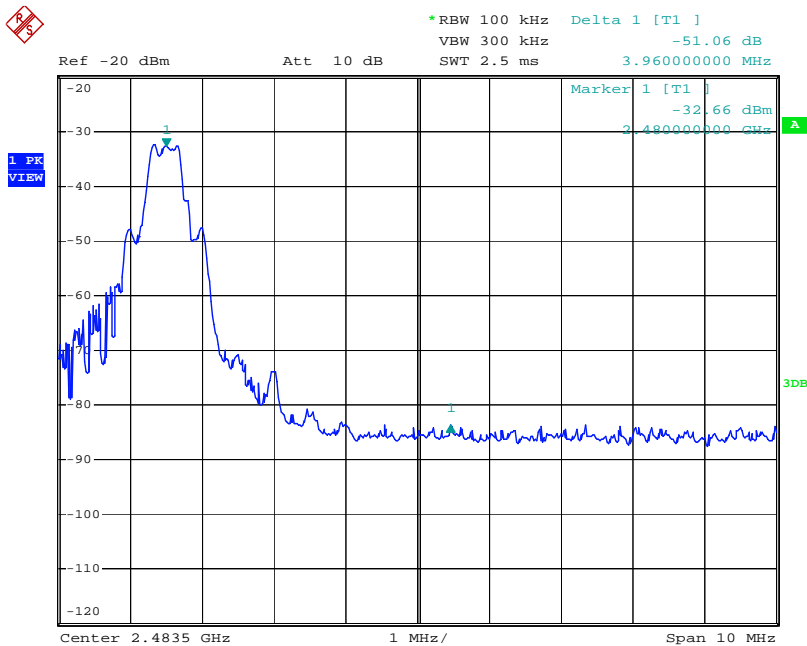
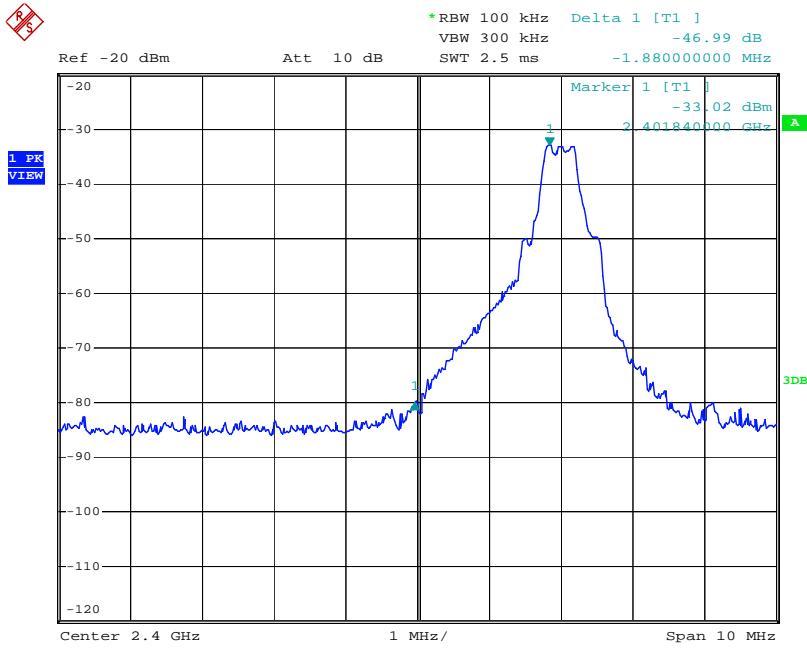

TEST REPORT

Peak Measurement

Bandedge compliance is determined by applying marker-delta method, i.e. (Bandedge Plot).

Lower bandedge

Peak Resultant field strength = Fundamental emissions (peak value) – delta from the plot

=90.8 dB μ V/m - 47.0 dB

=43.8 dB μ V/m

Average Resultant field strength = Fundamental emissions (average value) – delta from the plot

=66.8 dB μ V/m - 47.0 dB

=19.8 dB μ V/m

Upper bandedge

Peak Resultant field strength = Fundamental emissions (peak value) – delta from the plot

=91.1 dB μ V/m - 51.1 dB

=40.0 dB μ V/m

Average Resultant field strength = Fundamental emissions (average value) – delta from the plot

=67.1 dB μ V/m - 51.1 dB

=16.0 dB μ V/m

The resultant field strength meets the general radiated emission limit in Section 15.209, which does not exceed 74 dB μ V/m (Peak Limit) and 54 dB μ V/m (Average Limit).

TEST REPORT

8.2 Discussion of Pulse Desensitization

Pulse desensitivity is not applicable for this device. The effective period (Teff) is approximately 0.625ms for a digital "1" bit which illustrated on technical specification, with a resolution bandwidth (3dB) of 1MHz, so the pulse desensitivity factor is 0dB.

8.3 Calculation of Average Factor

Based on the Bluetooth Specification Version 3.0 + EDR, the transmitter ON time for each timeslot of Bluetooth is 625µs. DH5 has the maximum duty cycle, which consists of 5 continuous Tx slots and 1 Rx slot. Therefore one hopset take $(5+1) \times 625\mu\text{s} = 3.75\text{ms}$. For one period for a pseudo-random hopping through at least 20 RF channels in adaptive mode (worse case), it take: $20 \times 3.75\text{ms} = 75\text{ms}$.

The dwell time for DH5 is $5 \times 625\mu\text{s} = 3.125\text{ms}$.

For the worst case calculation, there are two transmissions might occur in 100ms. Therefore,

$$\begin{aligned}\text{Duty Cycle (DC)} &= \text{Maximum On time in 100ms}/100\text{ms} \\ &= 3.125\text{ms} \times 2/100\text{ms} \\ &= 0.0625\end{aligned}$$

$$\begin{aligned}\text{Average Factor (AF) of Bluetooth in dB} &= 20 \log_{10} (0.0625) \\ &= -24 \text{ dB}\end{aligned}$$

TEST REPORT

8.4 Emissions Test Procedures

The following is a description of the test procedure used by Intertek Testing Services Hong Kong Ltd. in the measurements of transmitter operating under the Part 15, Subpart C rules.

The transmitting equipment under test (EUT) is placed on a wooden turntable which is four feet in diameter and approximately 0.8m in height above the ground plane for emission measurement at or below 1GHz and 1.5m in height above the ground plane for emission measurement above 1GHz. During the radiated emissions test, the turntable is rotated and any cables leaving the EUT are manipulated to find the configuration resulting in maximum emissions. The EUT is adjusted through all three orthogonal axis to obtain maximum emission levels. The antenna height and polarization are also varied during the testing to search for maximum signal levels. The height of the antenna is varied from one to four meters.

Detector function for radiated emissions is in peak mode. Average readings, when required, are taken by measuring the duty cycle of the equipment under test and subtracting the corresponding amount in dB from the measured peak readings. A detailed description for the calculation of the average factor can be found in Exhibit 8.3.

The frequency range scanned is from the lowest radio frequency signal generated in the device which is greater than 9 kHz to the tenth harmonic of the highest fundamental frequency or 40 GHz, whichever is lower. For line conducted emissions, the range scanned is 150 kHz to 30 MHz.

TEST REPORT

8.4 Emissions Test Procedures (cont'd)

The EUT is warmed up for 15 minutes prior to the test.

AC power to the unit is varied from 85% to 115% nominal and variation in the fundamental emission field strength is recorded. If battery powered, a new, fully charged battery is used.

Conducted measurements were made as described in ANSI C63.10 (2013).

The IF bandwidth used for measurement of radiated signal strength was 100 kHz or greater when frequency is below 1000 MHz. Where pulsed transmissions of short enough pulse duration warrant, a greater bandwidth is selected according to the recommendations of Hewlett Packard Application Note 150-2. A discussion of whether pulse desensitization is applicable to this unit is included in this report (See Exhibit 8.1). Above 1000 MHz, a resolution bandwidth of 3 MHz is used.

Transmitter measurements are normally conducted at a measurement distance of three meters. However, to assure low enough noise floor in the forbidden bands and above 1 GHz, signals are acquired at a distance of one meter or less. All measurements are extrapolated to three meters using inverse scaling, unless otherwise reported. Measurements taken at a closer distance are so marked.

TEST REPORT

8.4.1 Radiated Emission Test Setup

The figure below shows the test setup, which is utilized to make these measurements.

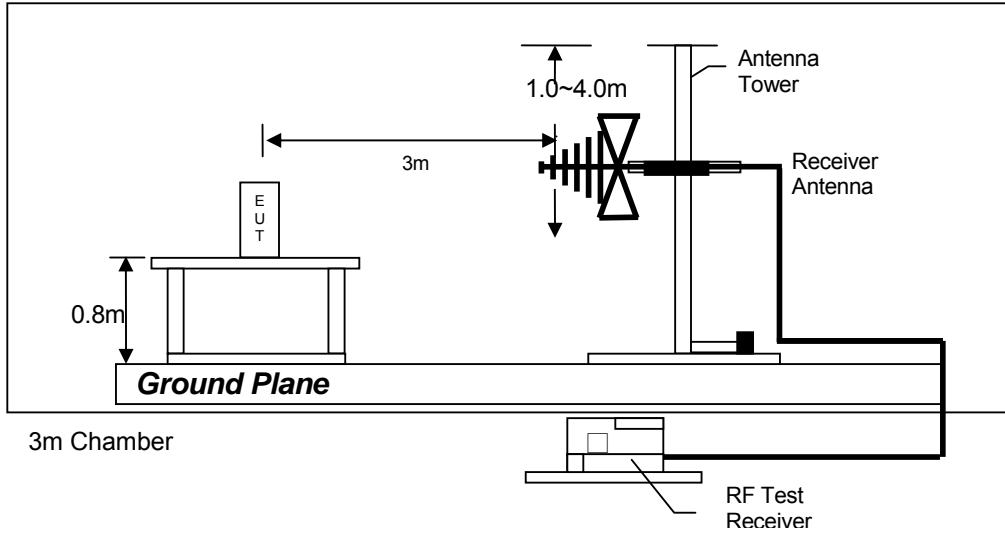

Test setup of radiated emissions up to 1GHz

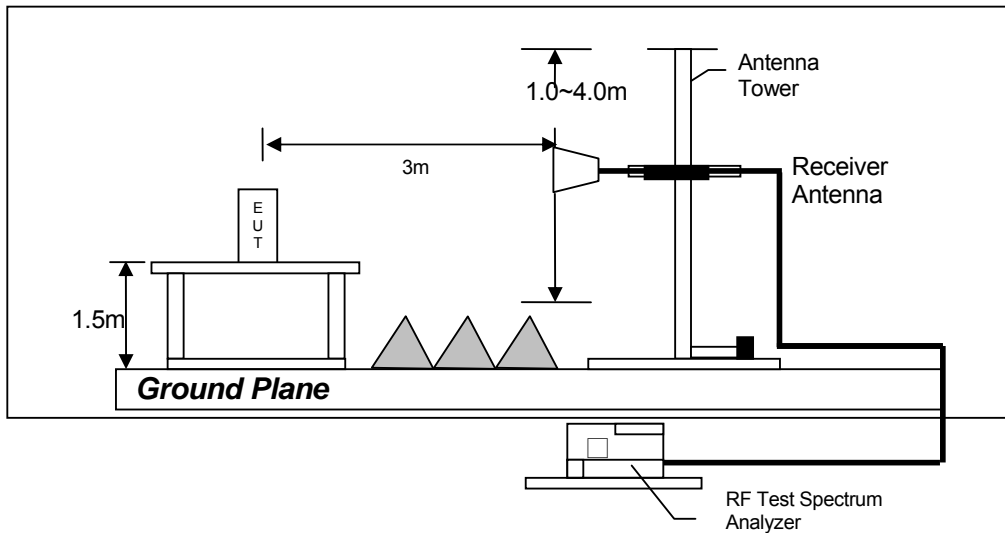

Test setup of radiated emissions above 1GHz

TEST REPORT

8.4.2 Conducted Emission Test Procedures

For tabletop equipment, the EUT along with its peripherals were placed on a 1.0m(W)×1.5m(L) and 0.8m in height wooden table. For floor-standing equipment, the EUT and all cables were insulated, if required, from the ground plane by up to 12 mm of insulating material. The EUT was adjusted to maintain a 0.4 meter space from a vertical reference plane. The EUT was connected to power mains through a line impedance stabilization network (LISN), which provided 50 ohm coupling impedance for measuring instrument and the chassis ground was bounded to the horizontal ground plane of shielded room. The excess power cable between the EUT and the LISN was bundled.

All connecting cables of EUT and peripherals were moved to find the maximum emission.

8.4.3 Conducted Emission Test Setup

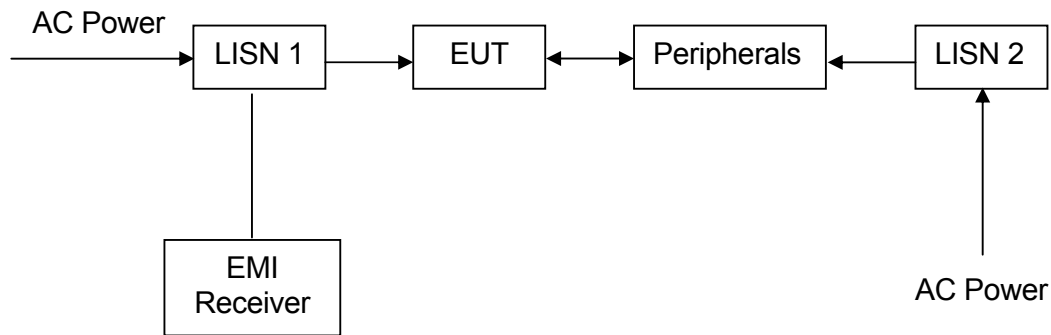

TEST REPORT

9.0 CONFIDENTIALITY REQUEST

For electronic filing, a preliminary copy of the confidentiality request is saved with filename: request.pdf.

10.0 EQUIPMENT LIST

1) Radiated Emissions Test

Equipment	EMI Test Receiver	Spectrum Analyzer	Log Periodic Antenna
Registration No.	EW-3156	EW-3281	EW-1042
Manufacturer	R&S	ROHDESCHWARZ	EMCO
Model No.	ESR26	FSV40	3148
Calibration Date	Dec. 06, 2016	Dec. 19, 2016	Jun. 19, 2017
Calibration Due Date	Dec. 06, 2017	Dec. 19, 2017	Dec. 19, 2018

Equipment	Biconical Antenna	Notch Filter (cutoff frequency 2.4GHz to 2.5GHz) 2 pieces	Double Ridged Guide Antenna
Registration No.	EW-2512	EW-2213	EW-0194
Manufacturer	EMCO	MICROTRONICS	EMCO
Model No.	3104C	BRM50701-02	3115
Calibration Date	Nov. 16, 2016	May 26, 2017	Aug. 10, 2016
Calibration Due Date	May. 16, 2018	May 26, 2018	Feb. 10, 2018

Equipment	RF Cable (up to 40GHz)	RF Pre-amplifier 3 pcs (9kHz to 40GHz)	12 metre RF Cable 40GHz
Registration No.	EW-3155	EW-3006	EW-2774
Manufacturer	N/A	SCHWARZBECK	GREATBILLION
Model No.	1-40 GHz	BBV 9718 BBV9744 BBV 9721	SMA m-m ra 12m 40G outdoor
Calibration Date	Dec. 05, 2016	Mar. 23, 2017	Nov. 24, 2016
Calibration Due Date	Dec. 05, 2017	Mar. 23, 2018	Nov. 24, 2017

Equipment	High Pass Filter 3GHz to 12GHz (2 Pieces)
Registration No.	EW-1835
Manufacturer	KLMICROWAVE
Model No.	11SH10-3000/T12000-0/OP
Calibration Date	Mar. 22, 2017
Calibration Due Date	Mar. 22, 2018

TEST REPORT

2) Conducted Emissions Test

EQUIPMENT	EMI TEST RECEIVER	LISN
Registration No.	EW-2251	EW-2874
Manufacturer	R&S	R&S
Model No.	ESCI	ENV-216
Calibration Date	Mar. 03, 2017	Mar. 16, 2017
Calibration Due Date	Mar. 03, 2018	Mar. 16, 2018

3) Bandedge Measurement

EQUIPMENT	SPECTRUM ANALYZER
Registration No.	EW-2249
Manufacturer	R&S
Model No.	FSP30
Calibration Date	Dec. 23, 2016
Calibration Due Date	Nov. 27, 2017

END OF TEST REPORT