

The Technical Description of GH5810US

1. RF Module

1-1. 2.4 Ghz

<TX part>

The TX VCO generates the transmitting frequency, and it is controlled by the MPU in the base-band through the Phase Local Loop IC (SIT8825). The out put signal is doubled by the TX-BUF and amplified by power amplifier Q304 and Q303, then fed to the antenna.

The audio signal is fed to the MIC-AMP from the base band part and then modulated to the RF signal in TX VCO through the compressor.

The data is used to transfer the commends between the base unit and the handset

<RX part>

The received signal from the antenna is fed to the mixer (Q307) after amplified by LNA-1 and LNA-2 (Q306 and Q307). In the mixer it is mixed with the local frequency generated by the RX VCO (Q302) and doubled by doubler converted to the IF (10.7MHz) signal, the RX VCO (Q302) is controlled by the MPU in the base-band part.

After amplified by IF-Amp IC302 (KA3361BD) the IF signal is fed to the FM-demodulator in which the audio signal is picked up. The audio signal is fed to the base-band part through the expander and the speaker amplifier Q2 .

1-2. 5.8Ghz

<TX part>

The TX VCO generates the transmitting frequency, and it is controlled by the MPU in the base-band through the Phase Local Loop IC (SIT8825). The out put signal is doubled by the TX-BUF and amplified by power amplifier Q304 and Q303, then fed to the antenna.

The audio signal is fed to the MIC-AMP from the base band part and then modulated to the RF signal in TX VCO through the compressor.

The data is used to transfer the commends between the base unit and the handset

<RX part>

The received signal from the antenna is fed to the mixer (Q307) after amplified by LNA-1 and LNA-2 (Q306 and Q307). In the mixer it is mixed with the local frequency generated by the RX VCO (Q302) and doubled by multiplied by 5mutiple converted to the IF (10.7MHz) signal, the RX VCO (Q302) is controlled by the MPU in the base-band part.

After amplified by IF-Amp IC302 (KA3361BD) the IF signal is fed to the FM-demodulator in which the audio signal is picked up. The audio signal is fed to the base-band part through the expander and the speaker amplifier Q2.

9. BASE RF MODULE

9-1. RX PART

THE RECEIVER FRONT-END CONTAINS A BPF FILTER, AN RF LOW NOISE AMPLIFIER, A ACTIVE TRANSISTOR MIXER, A MONOLITHIC CRYSTAL FILTER AND 10.7MHz IF AMPLIFIER. ALSO IT INCLUDES BUFFER AMPLIFIERS FOR THE GENERATION OF LOCAL OSCILLATOR POWER.

THIS FRONT-END RECEIVER RECEIVES AN RF SIGNAL FROM THE ANTENNA. AND RF SIGNALS WITHIN THIS FREQUENCY RANGE IS: 2461.300MHz~2467.15MHz PASS THROUGH RF AMP (Q306) AND BPF FILTER.

AFTER PASSING THROUGH THE BPF FILTER, THE SIGNAL IS MIXED WITHIN 1'ST LOCAL FREQUENCY FROM VOLTAGE CONTROLLED OSCILLATOR.

THE SIGNAL IS AMPLIFIED ON THE IF AMP TRANSISTOR (Q308,Q310) AND THE SIGNAL PASS THROUGH THE CERAMIC FILTER (10.7MHz).

AFTER THE IF SIGNAL PASS THE CERAMIC FILTER, THE SIGNAL ENTER BY THE FM IF (INTERMEDIATE FREQUENCY) IC.

AND THE SIGNAL IS MIXED IN THE FM IF IC (KA8531).

THE OUTPUT SIGNAL IN THE FM IF IC STREAMS FROM THE AF-OUT TERMINAL OF THE CONNECTOR 1 TO THE BASE.

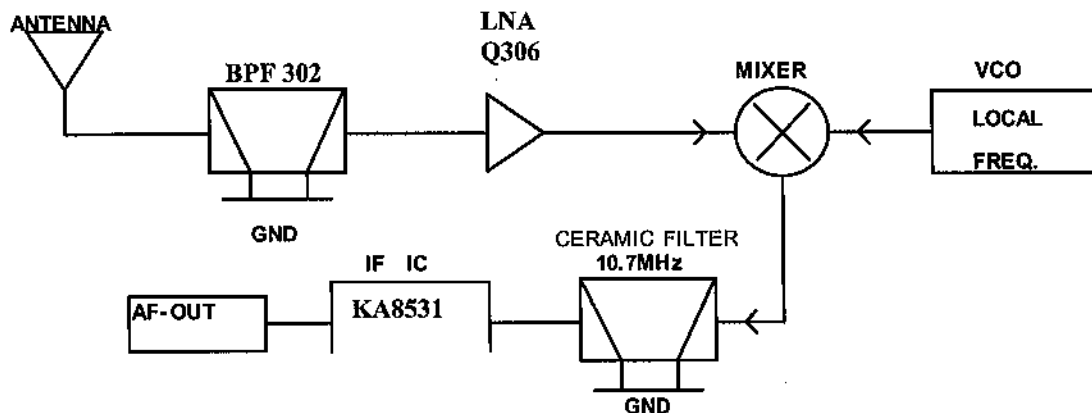

FIG.11

9-2. TX PART

THE SIGNAL IS MADE TO THE BASE, ENTER BY THE AF-IN TERMINAL OF THE CONNECTOR 1.

THE SIGNAL SEND THE MOD TERMINAL OF THE TX VCO.

THE SIGNAL IS MIXED IN THE TX VCO MIXING THE RF SIGNAL.

THE RF SIGNAL ENTER BY THE TRANSMISSION POWER AMP TRANSISTOR (Q304,303,311)
ENTER BY THE BPF FILTER.

THE RF SIGNAL PASS THROUGH THE BPF FILTER, TOWARDS THE ANT.

THE LAST TRANSMISSION RF SIGNAL IS 5792.050MHz ~ 5802.900MHz

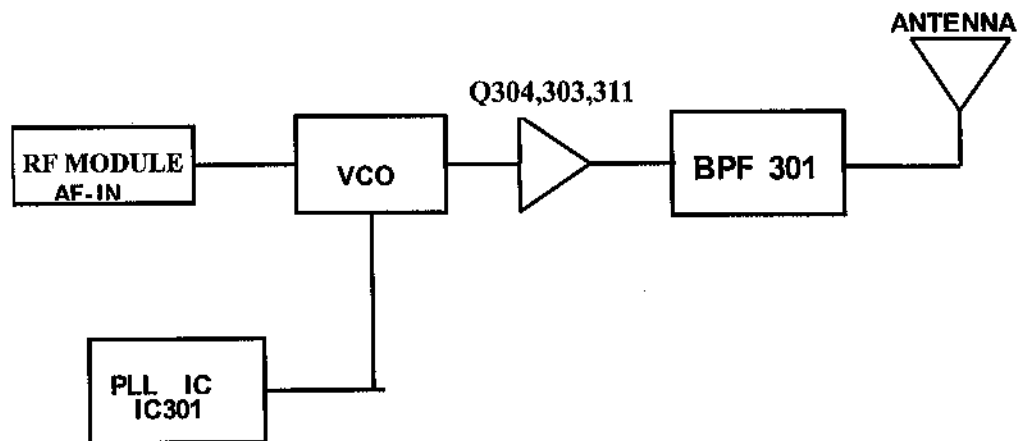

FIG. 12

2. The Base-Band Part of The Base Unit

Tel-line Interface,

Separate the incoming and outgoing audio signals and make the sidetone cancellation. Make the tel-line on-hook and off-hook.

Ring Detect and Branch Phone Detect,

Detects the ring signal from the telephone line in on-hook status and informs the MPU, and detects if the branch phone is in the off-hook mode or on-hook mode and then informs to the MPU.

Audio Path Switch Circuitry,

This circuitry can set up the path to implement the functions of talking with the telephone line, inter-communication, 3 way conference between the two handsets and telephone line. This circuitry is controlled by the MPU.

Power Control Circuitry,

Switch on or off the power of TX part and RX part of the RF module. It is controlled by the MPU.

REF. OSC (11.15MHz),

Provide the standard frequency to the Phase Local Loop IC of the RF module as the reference frequency

The MPU,

It is the central controller. It manages the all parts including the audio path switch circuitry to work properly and makes the communication with the handset through the RF link. The frequency of the clock is 32.768KHz.

3. The Base-Band Part of The Handset Unit

Key Board,

The user interface.

Power Control Circuitry,

Switch on or off the power of TX part and RX part of the RF module. It is controlled by the MPU.

Charge Circuitry and Charge Detector,

Charge the battery in the handset when the handset is in the base cradle and detect if the handset is charging or not, and then informs to the MPU.

REF. OSC (11.15MHz),

Provide the standard frequency to the Phase Local Loop IC of the RF module as the reference frequency.

The MPU,

It is the central controller. It manages the operation of the handset and communicates With the base unit through the RF link.

4. The Antennas

It is single pole type and soldered permanently on the RF module of both base and Handset.

The End.

GH5810 FREQUENCY LIST(SAMSUNG PLL)

1. 5.8GHz BAND

CHANNEL SPACE : 125KHz
 1st IF FREQUENCY : 10.5 MHz ,125KHz
 REFERENCE FREQUENCY : 11.15 MHz (10 PPM)
 CHANNEL : 40 CH

1. 2.4GHz BAND

CHANNEL SPACE : 100 KHz
 1st IF FREQUENCY : 10.7 MHz ,100KHz
 REFERENCE FREQUENCY : 11.15 MHz (10 PPM)
 CHANNEL : 40 CH

2003.5.14-1

CH	VCO FREQUENCY				CARRIER FREQUENCY			
	BASE				BASE			
	TX	LOCAL	TX	LOCAL	TX	LOCAL	TX	LOCAL
	B V fo	B V LO	H V fo	H V LO	B V fo * 5	B V LO *2	H V fo *2	H V LO *5
1	1159.525	1231.20	1236.55	1157.425	5797.625	2462.4	2473.1	5787.125
2	1159.550	1231.25	1236.60	1157.450	5797.750	2462.5	2473.2	5787.250
3	1159.575	1231.30	1236.65	1157.475	5797.875	2462.6	2473.3	5787.375
4	1159.600	1231.35	1236.70	1157.500	5798.000	2462.7	2473.4	5787.500
5	1159.625	1231.40	1236.75	1157.525	5798.125	2462.8	2473.5	5787.625
6	1159.650	1231.45	1236.80	1157.550	5798.250	2462.9	2473.6	5787.750
7	1159.675	1231.50	1236.85	1157.575	5798.375	2463.0	2473.7	5787.875
8	1159.700	1231.55	1236.90	1157.600	5798.500	2463.1	2473.8	5788.000
9	1159.725	1231.60	1236.95	1157.625	5798.625	2463.2	2473.9	5788.125
10	1159.750	1231.65	1237.00	1157.650	5798.750	2463.3	2474.0	5788.250
11	1159.775	1231.70	1237.05	1157.675	5798.875	2463.4	2474.1	5788.375
12	1159.800	1231.75	1237.10	1157.700	5799.000	2463.5	2474.2	5788.500
13	1159.825	1231.80	1237.15	1157.725	5799.125	2463.6	2474.3	5788.625
14	1159.850	1231.85	1237.20	1157.750	5799.250	2463.7	2474.4	5788.750
15	1159.875	1231.90	1237.25	1157.775	5799.375	2463.8	2474.5	5788.875
16	1159.900	1231.95	1237.30	1157.800	5799.500	2463.9	2474.6	5789.000
17	1159.925	1232.00	1237.35	1157.825	5799.625	2464.0	2474.7	5789.125
18	1159.950	1232.05	1237.40	1157.850	5799.750	2464.1	2474.8	5789.250
19	1159.975	1232.10	1237.45	1157.875	5799.875	2464.2	2474.9	5789.375
20	1160.000	1232.15	1237.50	1157.900	5800.000	2464.3	2475.0	5789.500
21	1160.025	1232.20	1237.55	1157.925	5800.125	2464.4	2475.1	5789.625
22	1160.050	1232.25	1237.60	1157.950	5800.250	2464.5	2475.2	5789.750
23	1160.075	1232.30	1237.65	1157.975	5800.375	2464.6	2475.3	5789.875
24	1160.100	1232.35	1237.70	1158.000	5800.500	2464.7	2475.4	5790.000
25	1160.125	1232.40	1237.75	1158.025	5800.625	2464.8	2475.5	5790.125
26	1160.150	1232.45	1237.80	1158.050	5800.750	2464.9	2475.6	5790.250
27	1160.175	1232.50	1237.85	1158.075	5800.875	2465.0	2475.7	5790.375
28	1160.200	1232.55	1237.90	1158.100	5801.000	2465.1	2475.8	5790.500
29	1160.225	1232.60	1237.95	1158.125	5801.125	2465.2	2475.9	5790.625
30	1160.250	1232.65	1238.00	1158.150	5801.250	2465.3	2476.0	5790.750
31	1160.275	1232.70	1238.05	1158.175	5801.375	2465.4	2476.1	5790.875
32	1160.300	1232.75	1238.10	1158.200	5801.500	2465.5	2476.2	5791.000
33	1160.325	1232.80	1238.15	1158.225	5801.625	2465.6	2476.3	5791.125
34	1160.350	1232.85	1238.20	1158.250	5801.750	2465.7	2476.4	5791.250
35	1160.375	1232.90	1238.25	1158.275	5801.875	2465.8	2476.5	5791.375
36	1160.400	1232.95	1238.30	1158.300	5802.000	2465.9	2476.6	5791.500
37	1160.425	1233.00	1238.35	1158.325	5802.125	2466.0	2476.7	5791.625
38	1160.450	1233.05	1238.40	1158.350	5802.250	2466.1	2476.8	5791.750
39	1160.475	1233.10	1238.45	1158.375	5802.375	2466.2	2476.9	5791.875
40	1160.500	1233.15	1238.50	1158.400	5802.500	2466.3	2477.0	5792.000