

www.tuv.com

1.6 User Manual

EC - Declaration of Conformity

We, ModeLabs Technologies Ltd of
31/F China Online Centre,
333 Lockhart Road,
Wan Chai, Hong Kong

declare under our sole responsibility that our product

BLUETREK UFO

to which this declaration refers is in conformity with the appropriate standards

EN300 328-02
EN301 489-17
EN301 489-01
EN50371
EN60950

Following the provisions of Radio and Telecommunications Terminal Equipment directive
1999/5/EC.

June 2007



Guillaume Ponticelli, Director of Development

FCC/ Industry Canada Notice

This device complies with Part 15 of the FCC rules. Operation is subject to the following two conditions: (1) This device may not cause harmful interference. (2) This device must accept any interference received, including interference that may cause undesired operation.

Caution: Changes or modifications to this Bluetooth® headset not expressly approved by the party responsible for compliance could void the user's authority to operate it.

This Class B digital apparatus complies with Canadian ICES-003.

Bluetooth® is a trademark owned by Bluetooth SIG, Inc. and is used by the manufacturer under license.

English

Before using your headset for the first time, you must charge it continuously for about 4 hours, until the red indicator light turns off. Please refer to the "Charging the BLUETREK® UFO" section of this manual. You also have to pair the headset with a mobile phone. Please refer to the "Pairing the BLUETREK® UFO" section of this manual.

A built-in voice alert is an advanced feature that is now available on your headset. A recorded voice reminds you of the actions in your headset, such as: redial the last number, reject a call, call your favourite number, when your headset needs to be charged and if your headset is connected/disconnected from the handset. You may choose to activate /inactivate this function by pressing both talk button and Vol+ for 3 seconds then switch on your headset again.

Introduction

The BLUETREK® UFO headset is a wireless headset based on the Bluetooth® technology. It complies with Bluetooth® 1.2 protocol, supporting Headset and Hands-free profile.

- 1 TALK button
- 2 VOL+ button
- 3 Pre-registered number 1
- 4 Indicator light
- 5 Pre-registered number 2
- 6 VOL- button
- 7 Charging socket

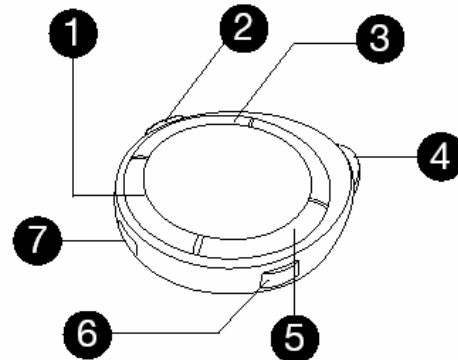

1 | BLUETREK UFO

Charging the BLUETREK® UFO

Please connect the charger to the headset and to the main. During the charge, the indicator light is red. The indicator light will turn off when the charge is complete. During subsequent charges, the charging should take approximately 3 hours.

When you hear a low-tone beep (or the voice alert if activated) in your headset at regular intervals, and the indicator light flashes in red, your headset needs to be recharged.

Important:

- If your headset is fully charged, the red indicator light will not turn on when plugging into the charger.
(To check whether your headset is fully charged, press the talk button for approx. 2 seconds, once released, the red indicator light will turn on for approx. 3 seconds.)
- To maximize battery lifetime, it is recommended to recharge your headset to full capacity only when the battery is low, since a battery has a lifetime of about 500 charging cycles.
- If you leave your headset battery empty for an extended period of time, it could excessively discharge the battery. In this case, charge your headset for 3 hours or more until the battery recovers and recharges completely. When you first charge the headset after prolonged storage, it may take few minutes for the red indicator light to turn on.
- Do not charge your headset for more than 10 hours.
- The use of any other charger will automatically suspend the warranty. It is strictly forbidden and can be very dangerous.

BLUETREK UFO I 2

Pairing the BLUETREK® UFO

Before using the BLUETREK® UFO headset, you must pair it with your Bluetooth® mobile phone. Pairing is the process of linking 2 Bluetooth® devices, so that they can communicate.

To initiate pairing:

- 1 Place the BLUETREK® UFO and your mobile phone within 0.3 meter (1 foot) from each other.
- 2 Switch on your phone and select its Bluetooth® discover mode (refer to the Bluetooth® mobile phone user manual).
- 3 When the BLUETREK® UFO is switched off, press and hold the TALK button for about 7 seconds until the indicator light flashes red and blue alternately. And a sound can be heard in the speaker.
- 4 Once the mobile phone detects the headset, a "BLUETREK UFO" message will be displayed. Follow the phone instructions to accept the pairing. The PIN code (or passkey) is 0000, then press "yes" or "ok".

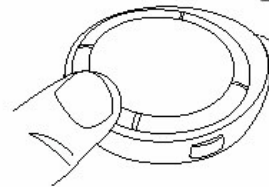
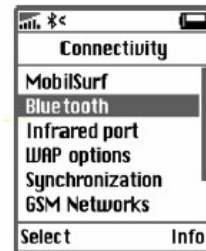

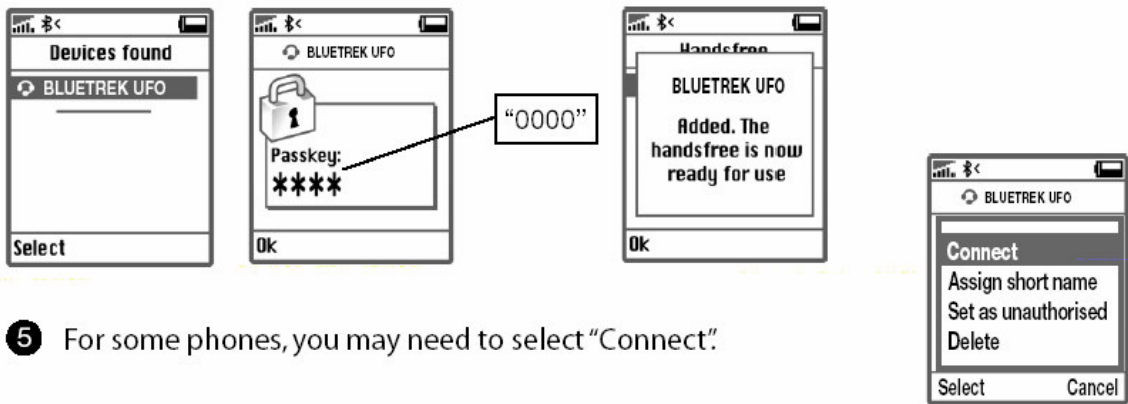

- 5 For some phones, you may need to select “Connect”.

If pairing was successful, the indicator light will switch to blue and flashes slowly. If you haven't started the discovery mode within 5 minutes, the headset will go to the standby mode. You must then switch off your headset and start the pairing again.

BLUETREK UFO I 4

English

Wearing the BLUETREK® UFO

Two different sizes of metal ear hooks and plastic ear hooks are included in the pack to suit your ear size. (Note: The ear hook is non-adjustable and non-rotatable. The warranty will be suspended if the ear hook hinge is damaged.)

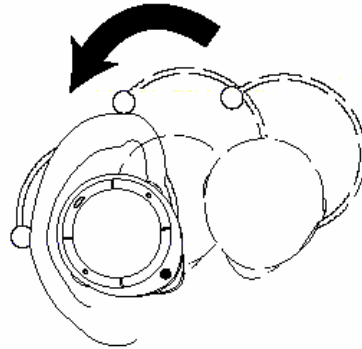

To attach the ear hook, simply insert the ear hook ring to the back of the headset gently as shown in the diagram.

For left ear wearing, the ear hook should be inserted from the right hand side.

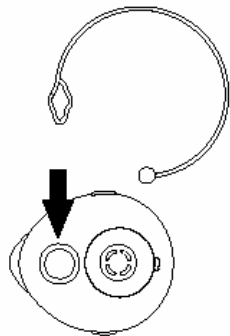

R

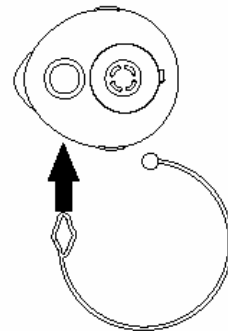

L

5 | BLUETREK UFO

Switching the BLUETREK® UFO ON and OFF

Switching BLUETREK® UFO ON

When your headset is off, press and hold the TALK button for about 3 seconds until the blue indicator light is on. A beep (2 tones) can be heard in the speaker. Release the TALK button.

Switching BLUETREK® UFO OFF

When your headset is on, press and hold the TALK button for about 7 seconds until the red indicator light is on. A beep (2 tones) can be heard in the speaker then release the TALK button.

Making a call

Mobile phone with voice recognition

- . Make sure the voice recognition function on your mobile is activated and your voice tags have been recorded with the phone. To enter these, please refer to your phone's manual.
- . When there is no incoming or active call, press once on the TALK button
- . Wait for the audio signal sent by the mobile phone (generally a short tone).
- . Speak the name of person you wish to call.

Mobile without voice recognition

- . Make sure both the headset and the mobile phone are ON and in stand-by mode.
- . Dial the number on the phone keypad, after approximately 2 seconds the audio connection will be established.

This function may not be available on some phones, please refer to the trouble shooting frequent asked questions in our website: www.bluetrek.com. to find out more.

BLUETREK UFO I 6

Answering a call

When the headset rings, press once on the TALK button to take the call.

Ending a call

Press once on the TALK button to end an active call.

Adjusting the volume

To increase the volume during an active call, press the "VOL+" button on the headset.

To decrease the volume during an active call, press the "VOL-" button on the headset.

7 | BLUETREK UFO

Muting the microphone

To mute the microphone during an active call

During an active call, press and hold the VOL+ button for approximately 3 seconds. A periodic tone can be heard in the speaker when the microphone is muted.

To end the mute function

When the microphone is muted, press and hold the VOL+ button on the BLUETREK® UFO for approx. 3 seconds. The periodic tone will end.

Transferring a call from BLUETREK® UFO to the mobile phone

During an active call, double click on the TALK button.

This function only works in the Hands-Free Profile.

In the Headset profile, you can simply turn off your headset.

Transferring a call from the mobile phone to the BLUETREK® UFO

During an active call on the mobile phone, press once on the TALK button to transfer the call.

This function may not be available depending on your phone.

BLUETREK UFO I 8

Pre-registered numbers feature

-This feature allows you to store your 2 favourite numbers in your BLUETREK® UFO headset and to dial these numbers directly from your headset.

(Important: This feature is only available in the Hands-free profile).

Storing your favourite numbers

- 1) Ensure your BLUETREK® UFO headset is paired and connected with your phone.
- 2) Enter numbers following the syntax describe below as your mobile phone name

(Please refer to your mobile phone manual to change your phone name. In most phones, the mobile phone name is under the "Bluetooth" menu)

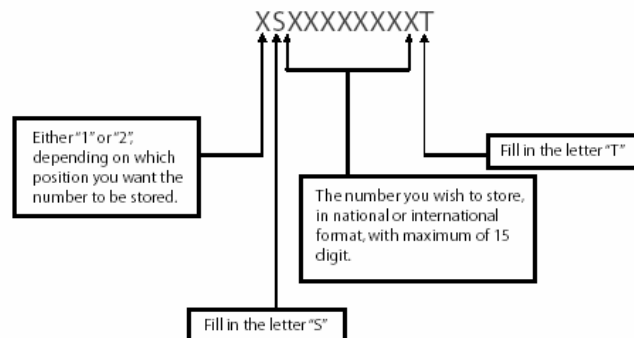

Example 1: To store "0123456789" in position 1 = 1S0123456789T

Example 2: To store "+44123456789" in position 2 = 2S+44123456789T

- 3) Press and hold the "Vol-" button on your BLUETREK® UFO headset for approx. 3 seconds, until the purple indicator light is on. (A beep can be heard in the speaker).
- 4) If the number is correct and have stored in the headset, you will hear:

1 beep in the speaker and the blue indicator light will flash once if the number has been stored in position 1.

OR

2 beeps in the speaker and the blue indicator light will flash twice if the number has been stored in position 2.

If the number is incorrect, it will not store in the headset. You will hear a long low-tone beep in the speaker and the red indicator light will flash twice.

Note:

- Only 1 telephone number can be stored at one time. To store the second number, simply repeat from Step 2.
- Maximum of 2 favourite numbers can be stored and can be replaced by repeating the above steps.
- Remember to change back your mobile phone name once you have stored the numbers.

Making a call to one of the stored numbers

- 1) Ensure your BLUETREK® UFO headset is paired and connected with your phone.
- 2) Press once on the pre-registered number 1 or pre-registered number 2 to call one of the stored numbers on your BLUETREK® UFO headset:
 - 1 beep (or the voice alert if activated) to call your number stored in position 1;
 - 1 beep (or the voice alert if activated) to call your number stored in position 2.

BLUETREK UFO I 10

Additional features with some phones

Rejecting a call

Press the TALK button for about 2 seconds to reject a call.

Redial the last number

When there is no incoming or active call, press the TALK button for about 3 seconds until you hear a beep (or the voice alert if activated).

Troubleshooting guide

The first thing you should do when encountering a problem that you cannot solve with this manual, is to switch off your headset and your mobile phone, and switch them on again.

To find out more, please refer to the trouble shooting frequent asked questions in our website: www.bluetrek.com.

Guidelines for safe use

Read those guidelines before using your headset.

- The volume level of the Bluetooth® headset may vary, depending on your mobile phone. Before using your headset for the first time, adjust the headset volume to the lowest, then increase the volume gradually until you reach to an acceptable level.
High levels of volume may result in hearing loss, avoid using the headset at high volume continuously. If you experience ringing in your ears or muffled speech, consult your doctor immediately and stop using the headset.
- Do not drop or try to alter the shape of your headset.
- Do not expose your headset to liquid or moisture.
- Do not expose your headset to extreme temperatures. Temperature range : 0-40°C.
- Do not expose your headset to fire or open flames.
- Do not try to disassemble your headset. Service and Maintenance can only be performed by authorized BLUETREK® dealers.
- Keep your headset away from dust and dirt.
- Do not let children play with your headset, since it contains small parts that could become detached and create a choking hazard.
- Check the regulation in your area if you plan to use your headset while driving.
- Turn off your headset before boarding an airplane.

CAUTION : The built-in battery is non-replaceable. Do not attempt to replace it. Danger of explosion if battery is incorrectly replaced. Dispose of batteries according to local regulations. Do not dispose as household waste.

BLUETREK UFO I 12