

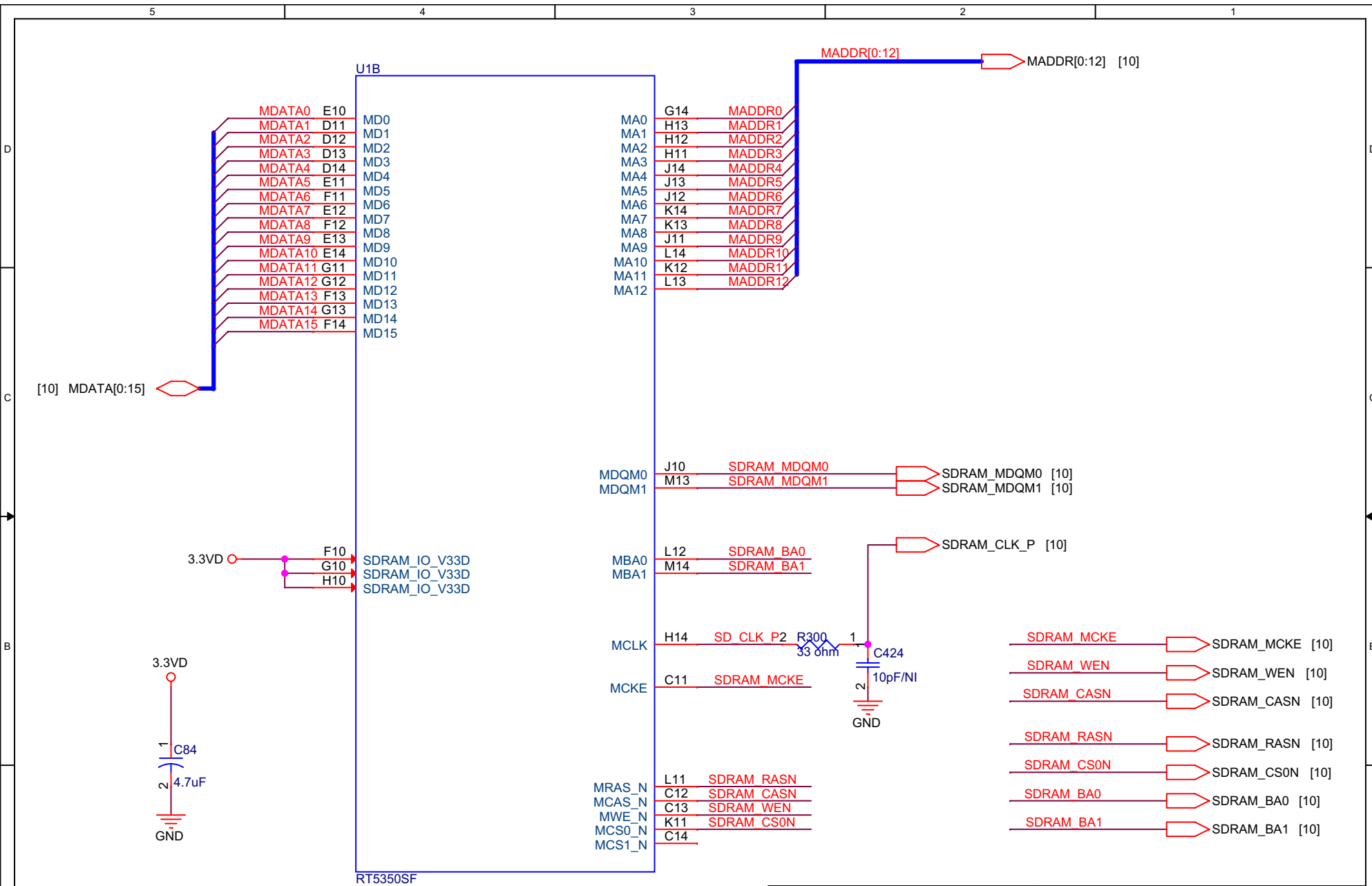

		<b>Title:</b> <b>RT5350 RF Power</b>	
		<b>Document Number:</b> <b>B10 Reader</b>	<b>Rev:</b> <b>0.10</b>
<b>Date:</b> Tuesday, October 23, 2012		<b>Sheet:</b> 1 Of 20	



		Title: <b>RT5350 SDRAM</b>	
		Document Number:	Rev: 0.10
		<b>B10 Reader</b>	
Date: Tuesday, October 23, 2012		Sheet: 2 of 20	

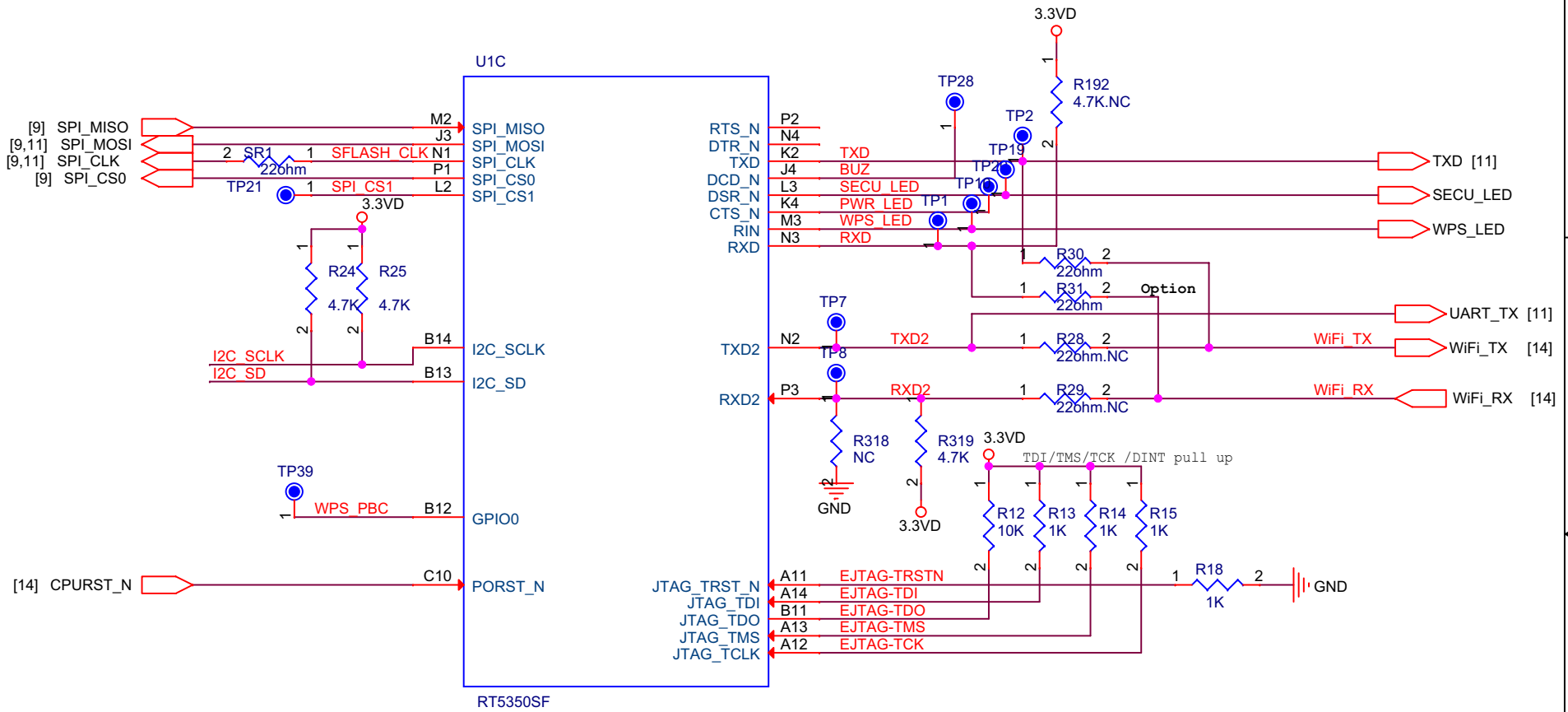

		Title: <b>RT5350 Peripheral-C</b>	
		Document Number:	Rev: 0.10
		<b>B10 Reader</b>	
Date: Tuesday, October 23, 2012		Sheet: 3 of 20	

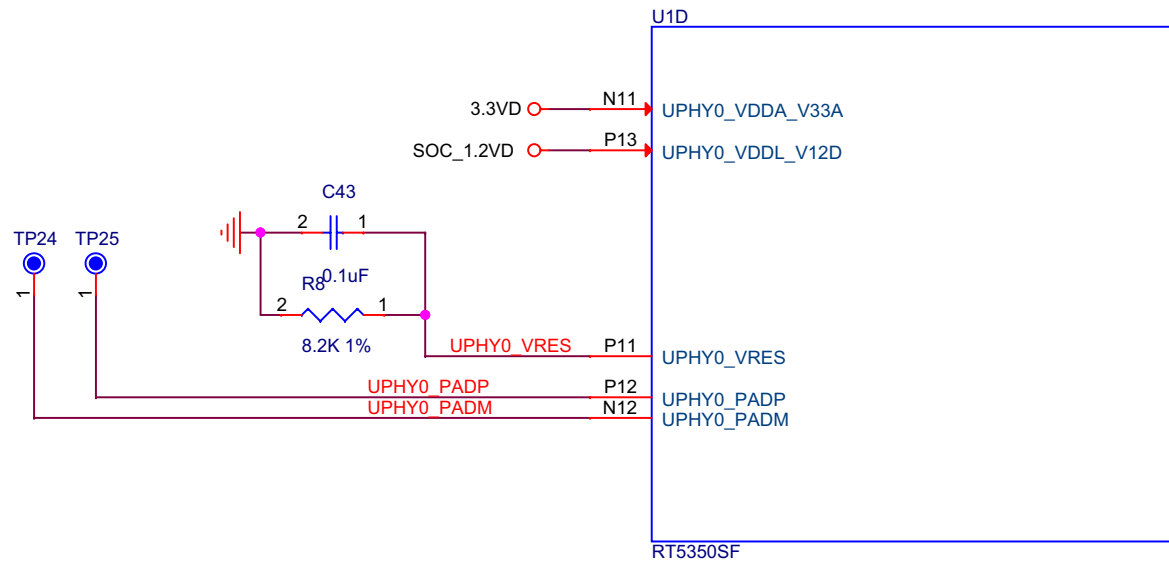

	Title: <b>RT5350 USB</b>	
	Document Number:	Rev: 0.10
	<b>B10 Reader</b>	
Date: Tuesday, October 23, 2012	Sheet: 4 of 20	

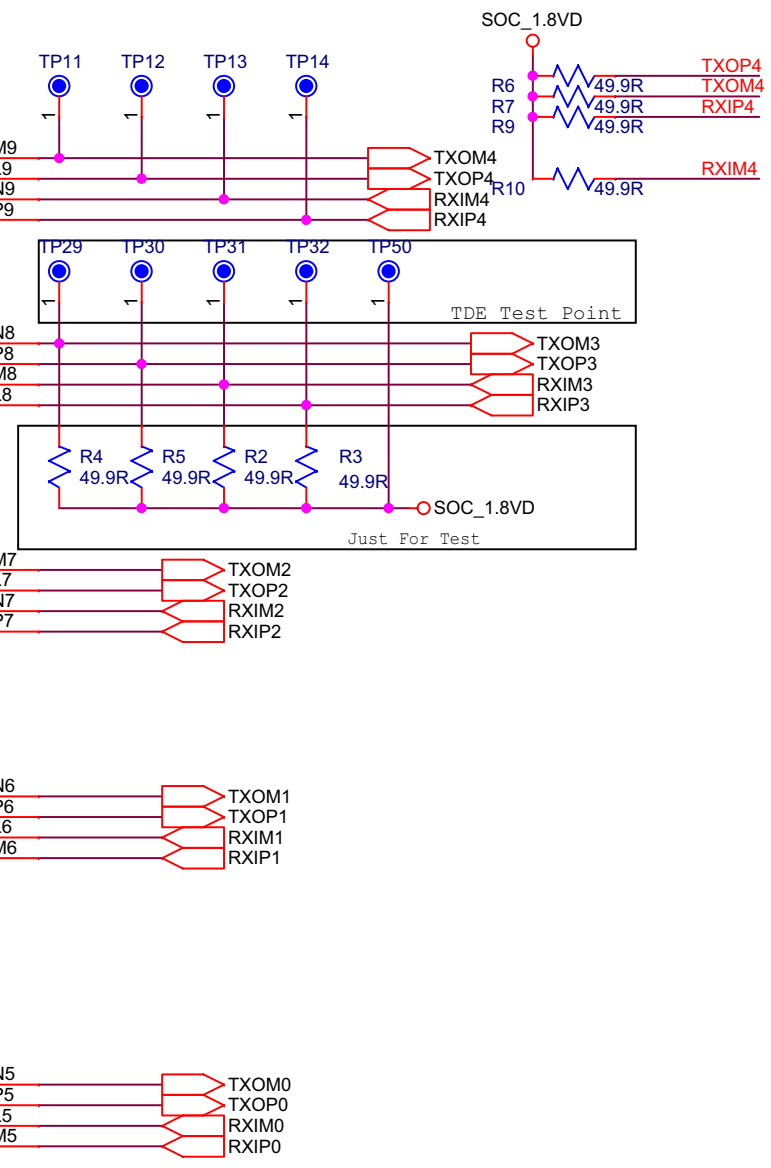
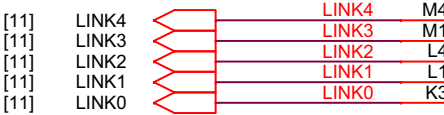
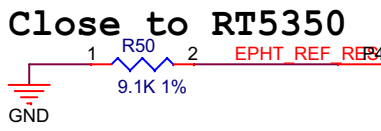
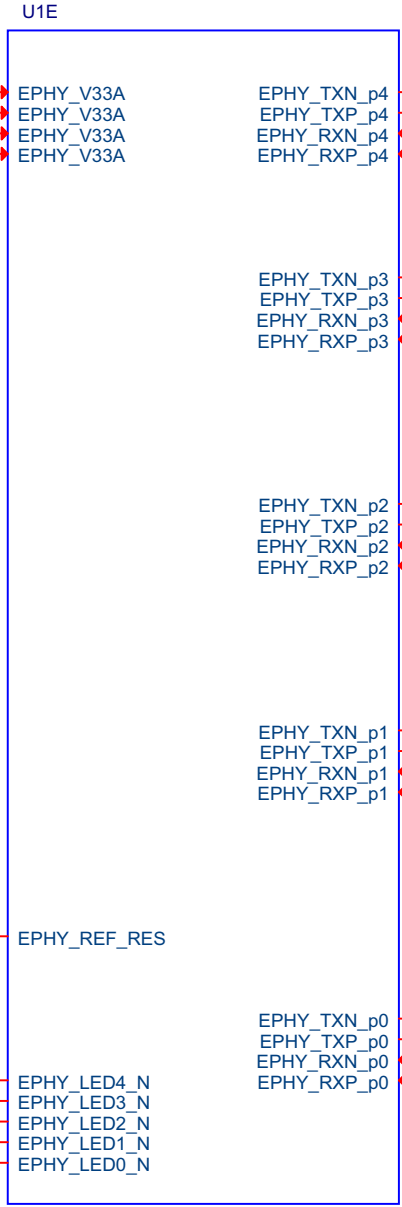
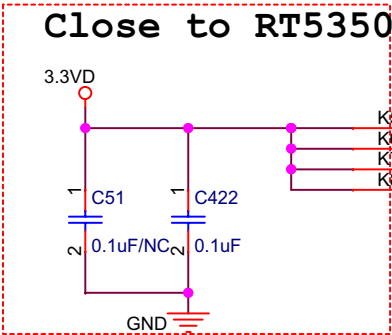

Title: <b>RT5350 ETH</b>	
Document Number:	Rev: 0.10
<b>B10 Reader</b>	
Date: Tuesday, October 23, 2012	Sheet: 5 of 20

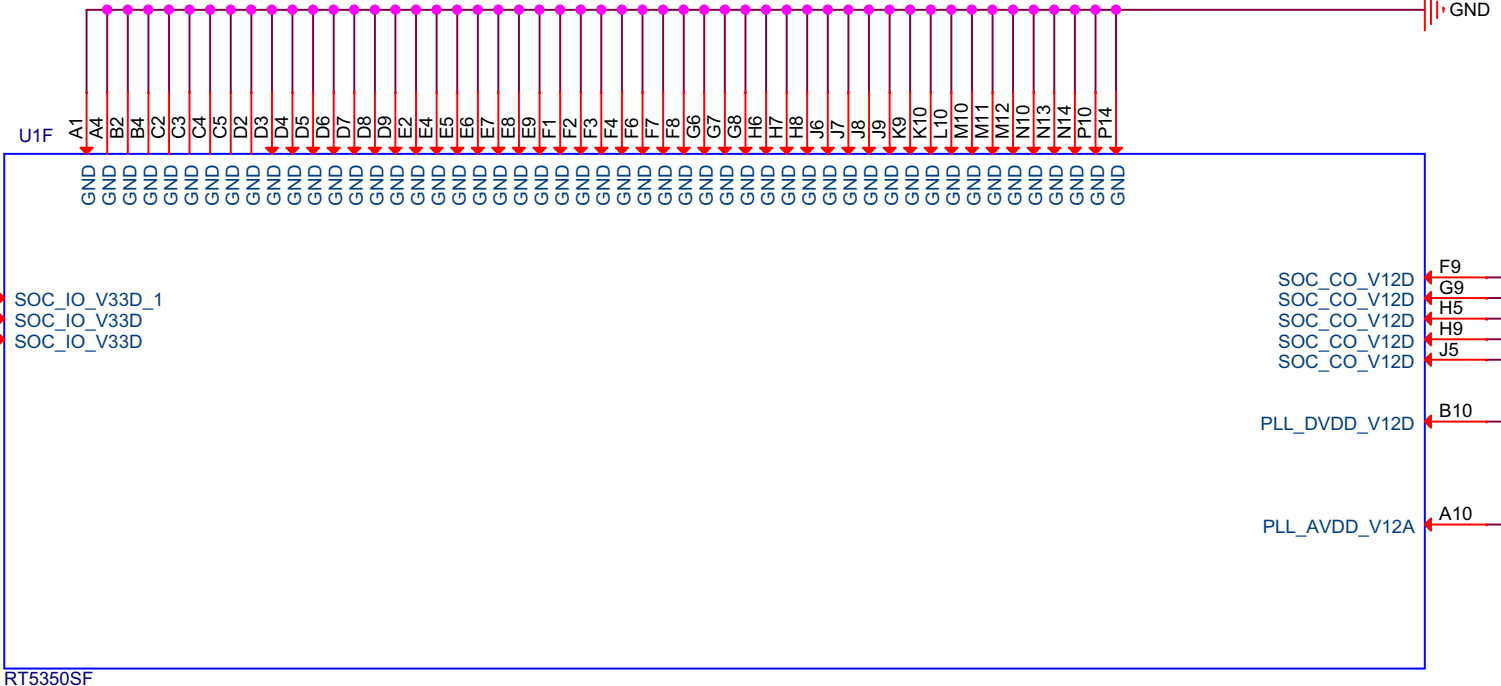

RT5350SF

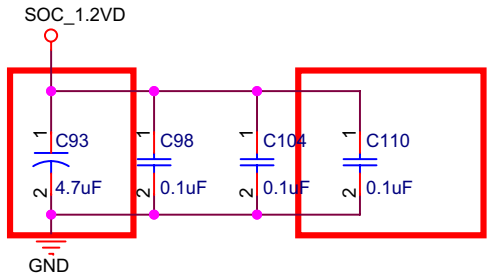

Title: <b>RT5350 Power</b>	
Document Number:	Rev: 0.10
<b>B10 Reader</b>	
Date: Tuesday, October 23, 2012	Sheet: 6 of 20

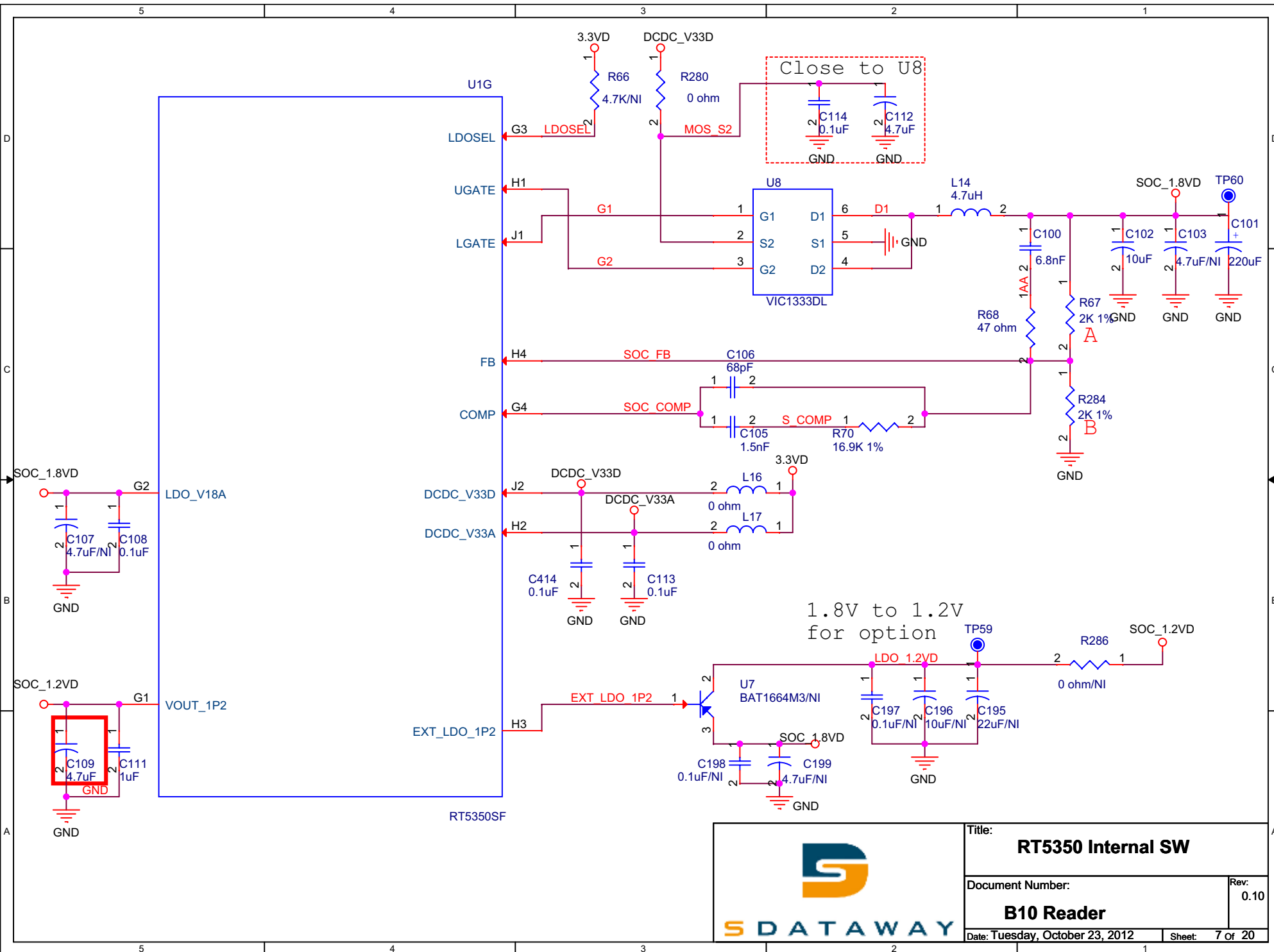

Title:		<b>RT5350 Internal SW</b>	
Document Number:		Rev: 0.10	
<b>B10 Reader</b>			
Date: Tuesday, October 23, 2012	Sheet: 7 of 20		

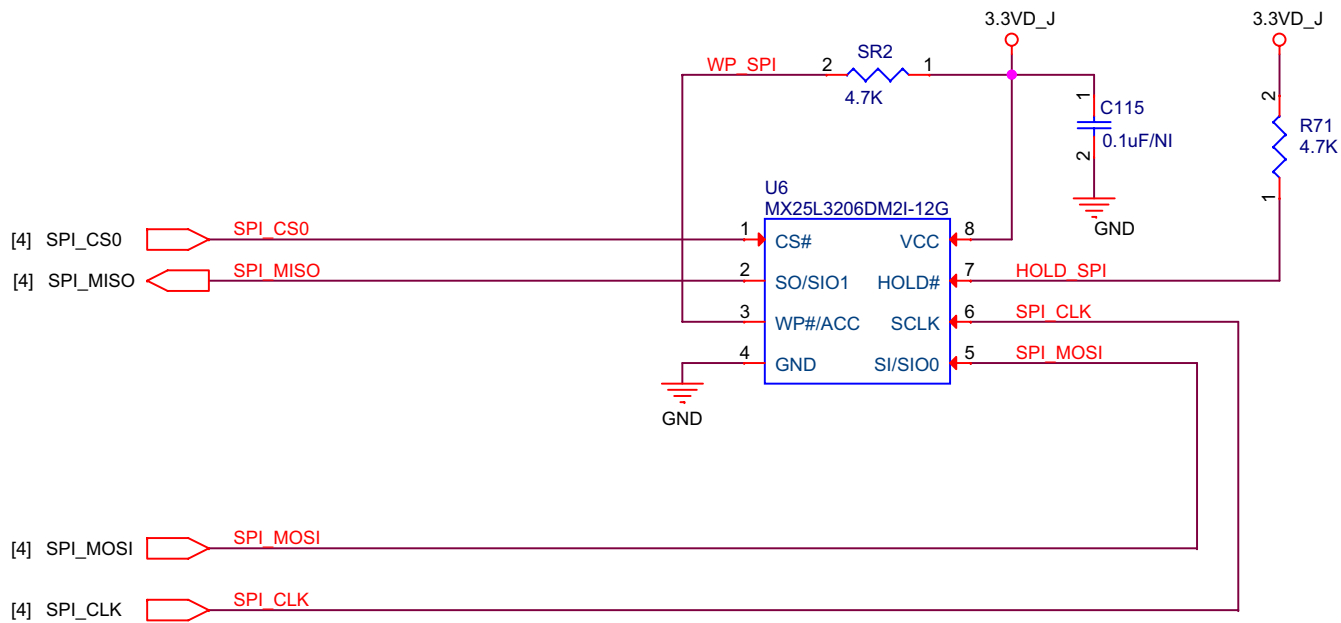

Title:		<b>SPI Flash</b>
Document Number:		
<b>B10 Reader</b>		Rev: 0.10
Date: Tuesday, October 23, 2012	Sheet:	8 of 20



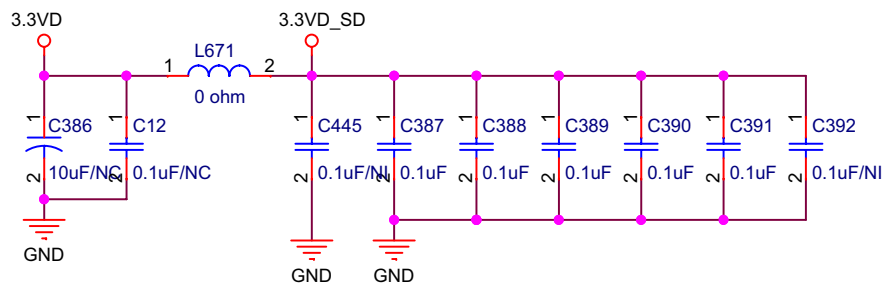
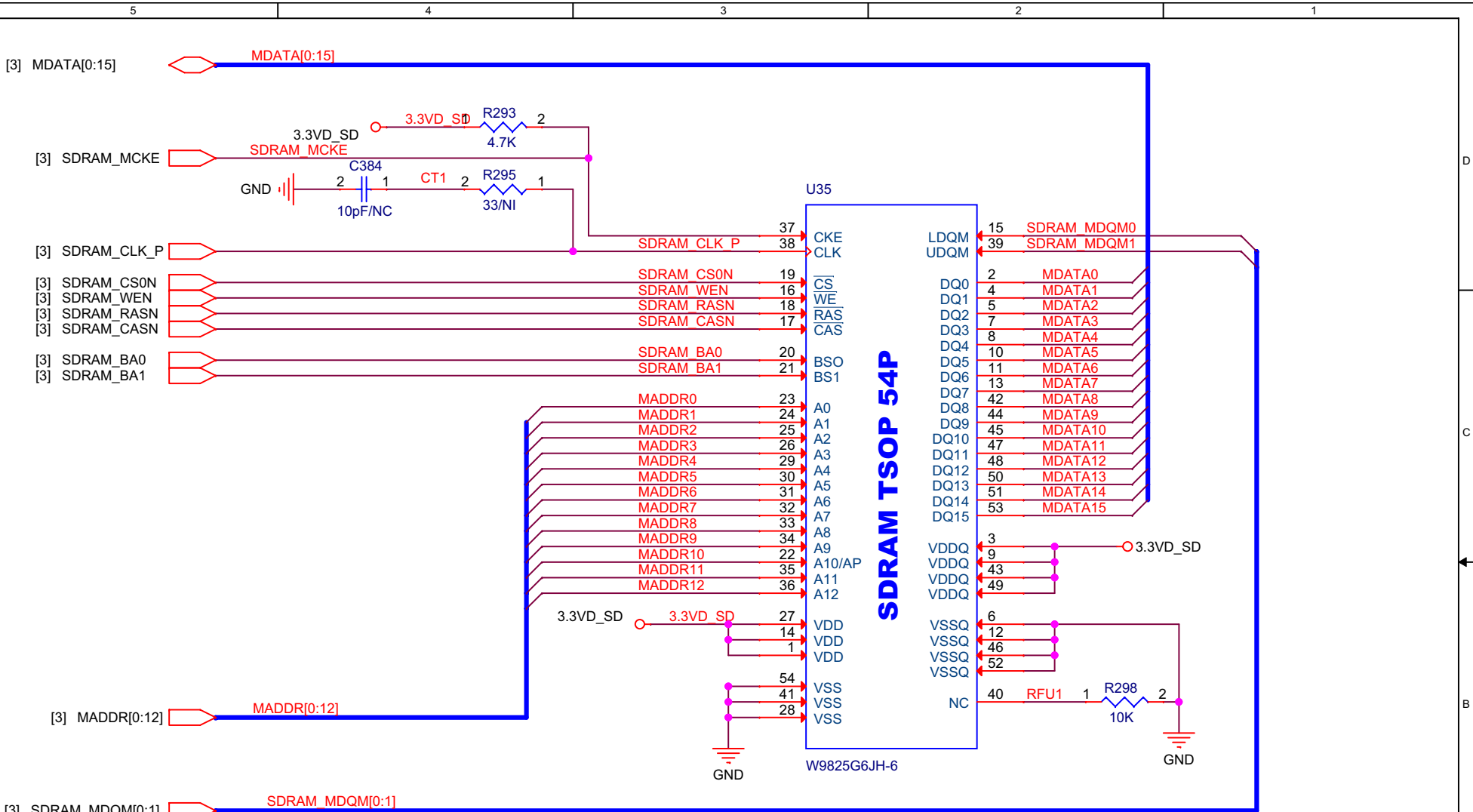

Title: <b>SDRAM</b>	
Document Number:	Rev: 0.10
<b>B10 Reader</b>	
Date: Tuesday, October 23, 2012	Sheet: 9 of 20

# RT5350 Boot Up Strapping

Pin Name	Description	Value=0	Value=1
SPI_CLK	XTAL_FREQ_HI	20MHz	40MHz
WLAN_LED_N	Big Endian	Little Endian	Big Endian
EPHY_LED4_N	DRAM_FROM_EE	from boot strapping	from EEPROM
{EPHY_LED3_N, EPHT_LED2_N}	DRAM_SIZE	INIC/AP(SDR) 0: 2MB/8MB 1: 8MB/16MB 2: 16MB/32MB 3: 32MB/64MB	
{EPHY_LED1_N, EPHT_LED0_N}	CPU_CLK_SEL	CPU clock select 0: 360MHz 1: Reserved 2: 320MHz 3: 300MHz	
{SPI_MOSI, TXD2, TXD}	CHIP_MODE[2:0]	A vector to set chip function/test/debug modes 0 : Normal mode(boot fromSPI serial flash) 1 : iNIC-USB mode 2 : Reserved 3 : Reserved 4 : Reserved 5 : iNIC-PHY mode 6 : SCAN mode 7 : TEST/DEBUG mode	

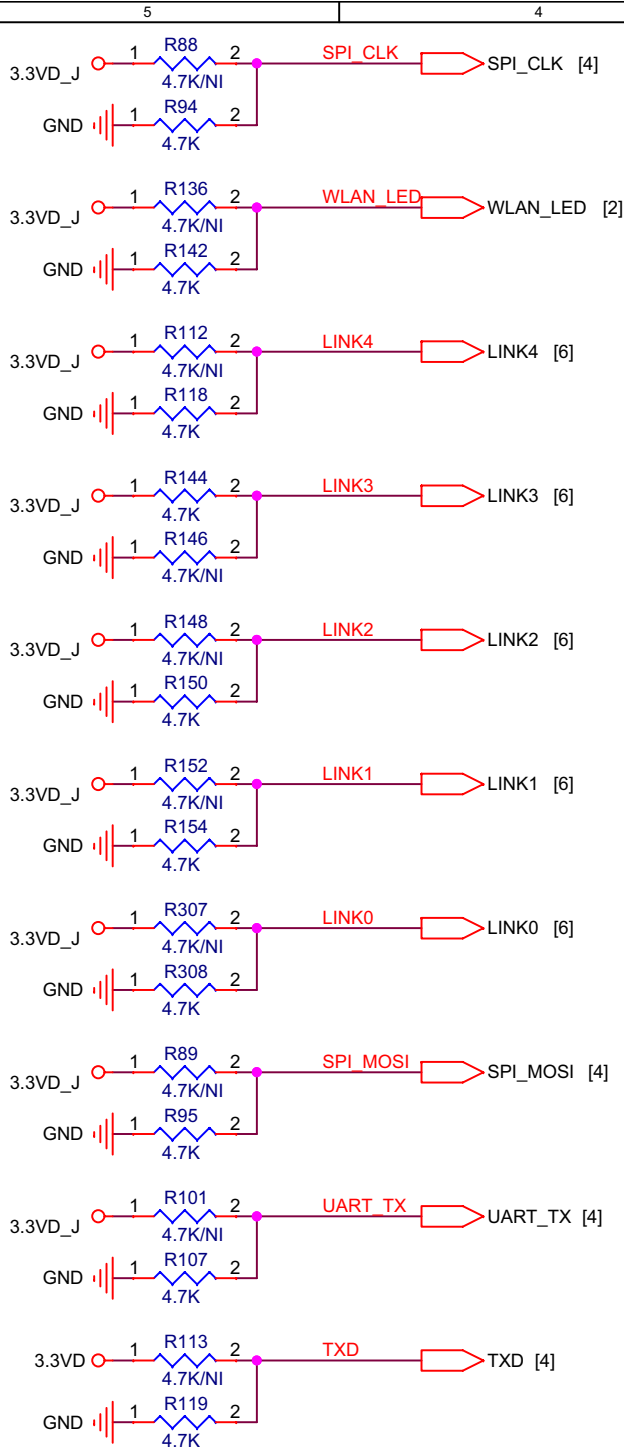

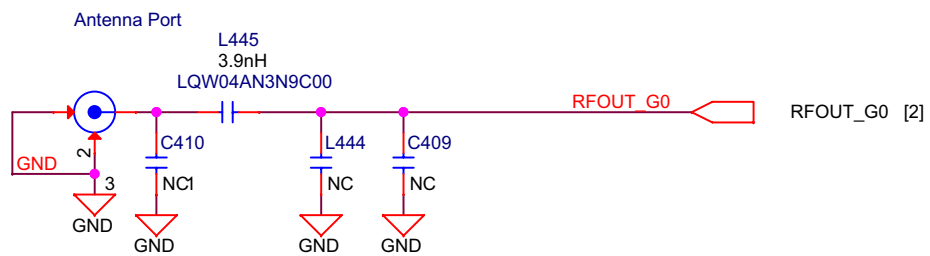

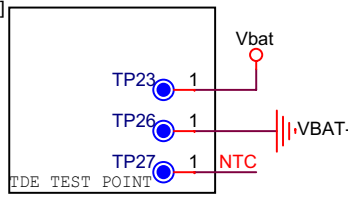
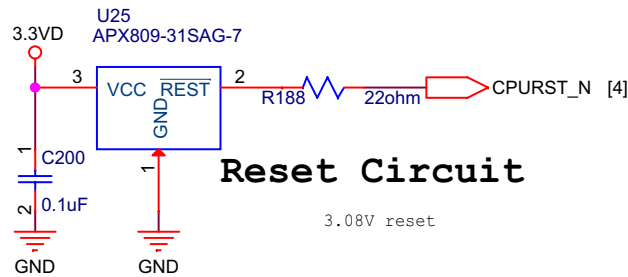
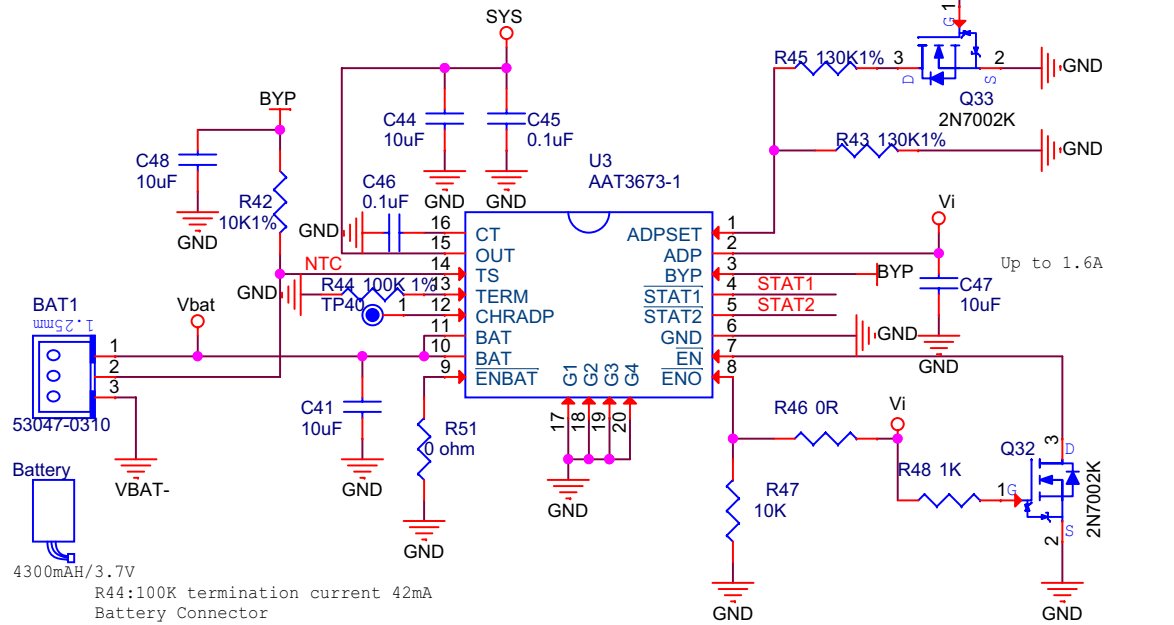
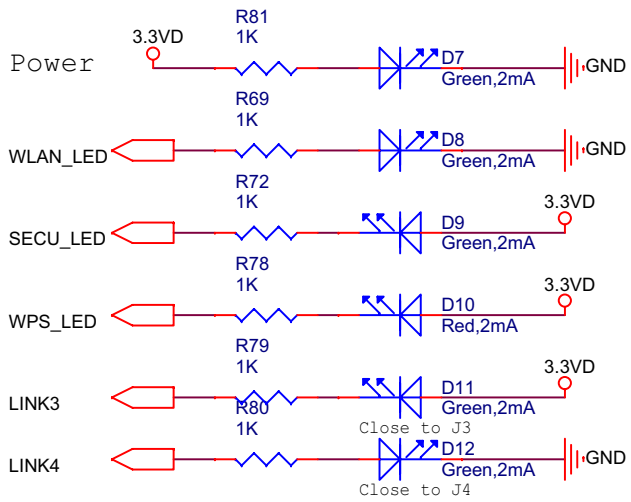
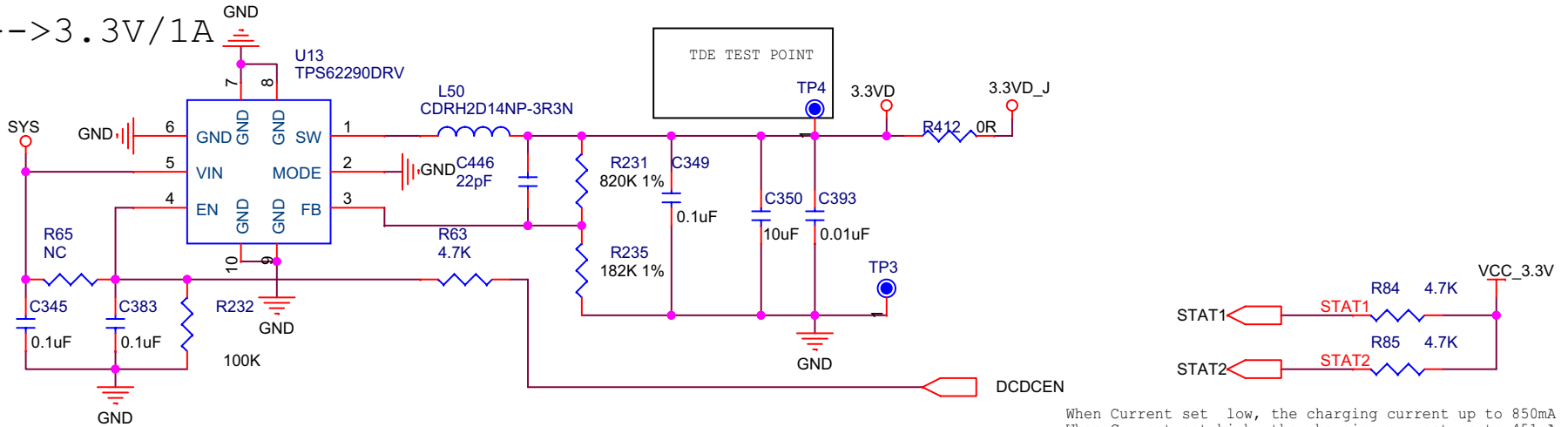

Title:		<b>Front END</b>
Document Number:		Rev: 0.10
<b>B10 Reader</b>		
Date: Tuesday, October 23, 2012	Sheet: 11 of 20	

Vi-->3.3V/1A

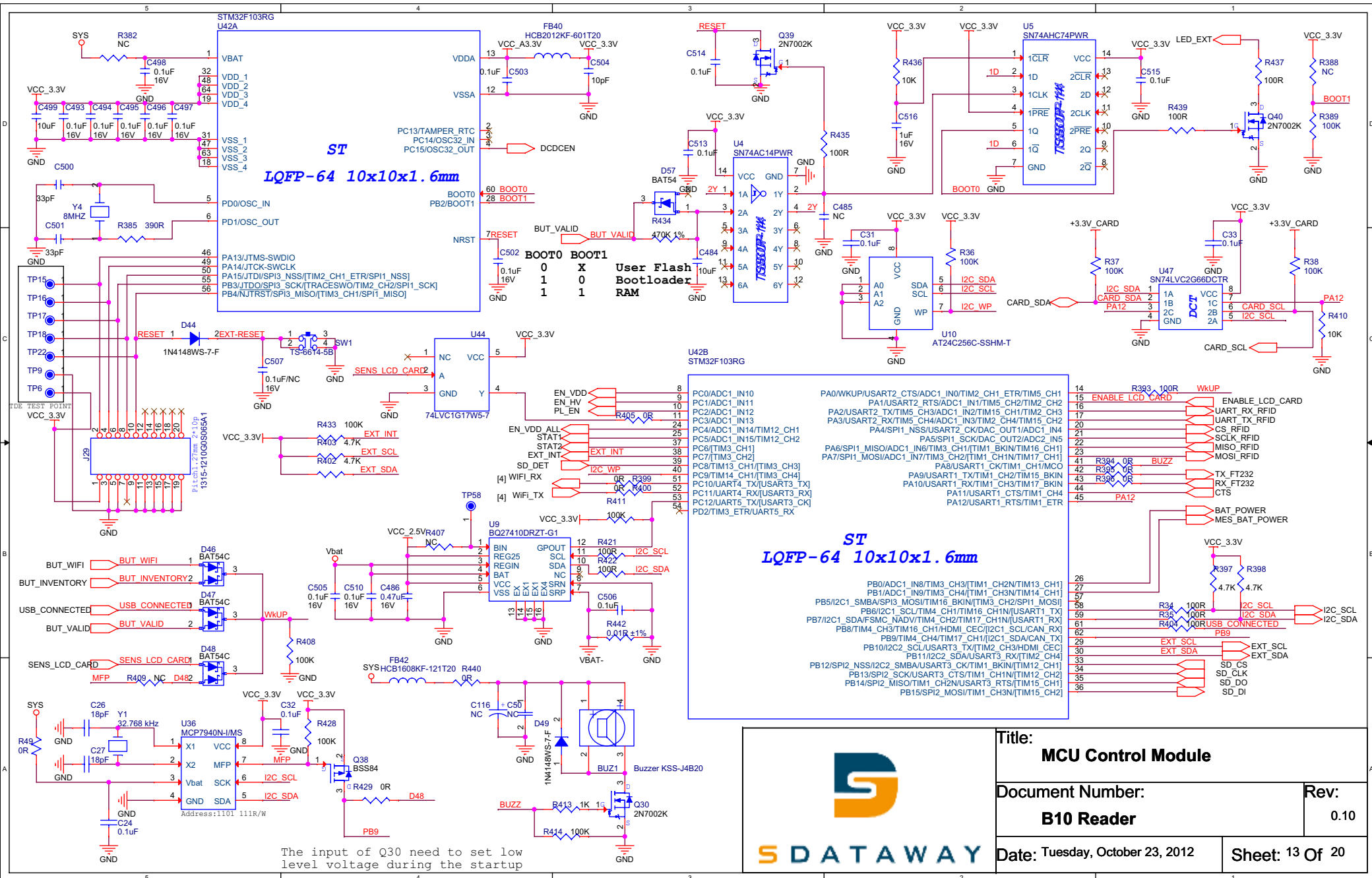

Title: <b>Power and Reset</b>	
Document Number:	Rev: 0.10
<b>B10 READER</b>	
Date: Tuesday, October 23, 2012	Sheet: 12 of 20





**Title:**  
MCU Control Module

**Document Number:**  
B10 Reader

**Date:** Tuesday, October 23, 2012

**Rev:**  
0.10

**Sheet:** 13 Of 20

Vi-->3.3V/1A

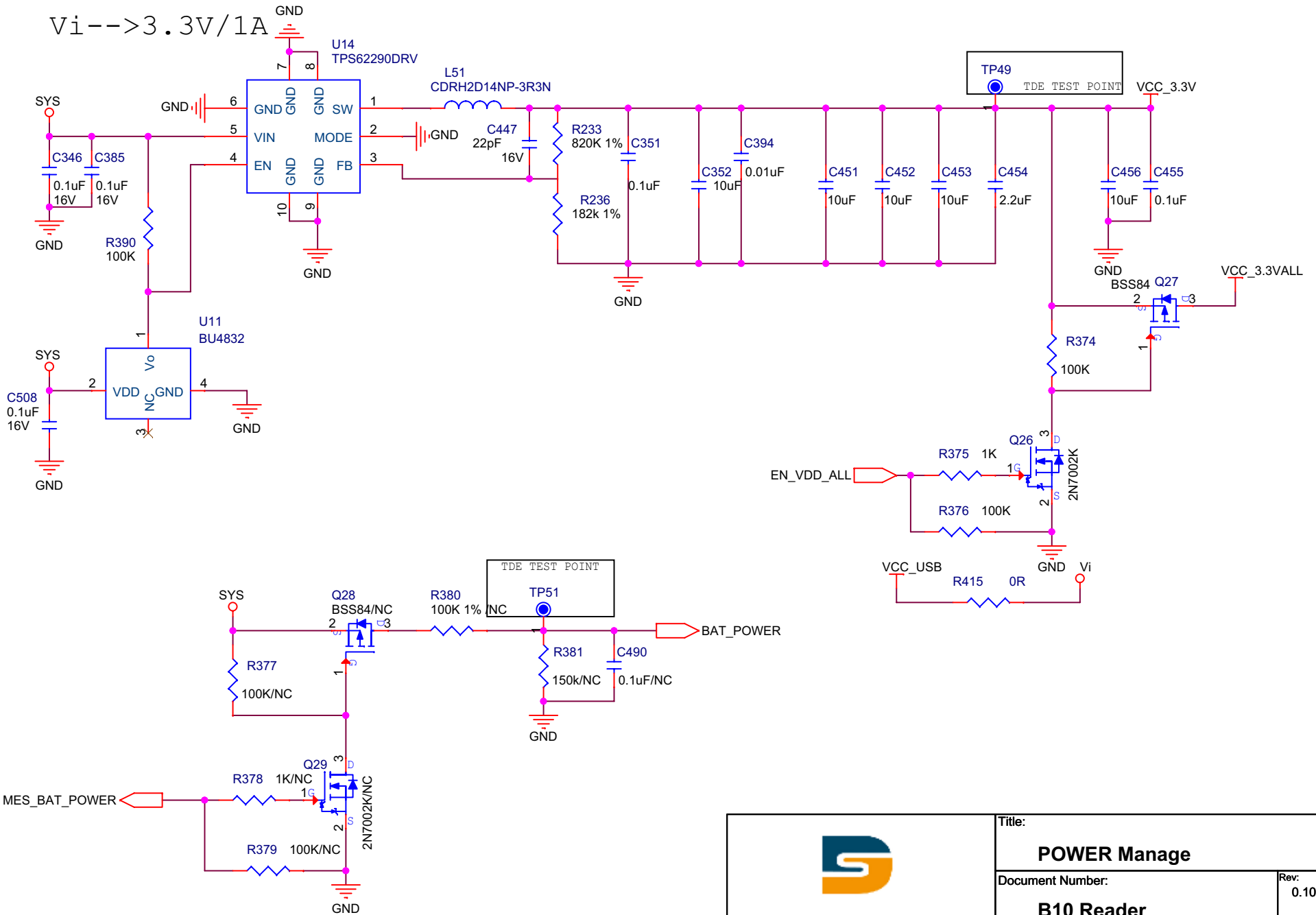

Title: <b>POWER Manage</b>	
Document Number:	Rev: 0.10
<b>B10 Reader</b>	
Date: Tuesday, October 23, 2012	Sheet: 14 of 20

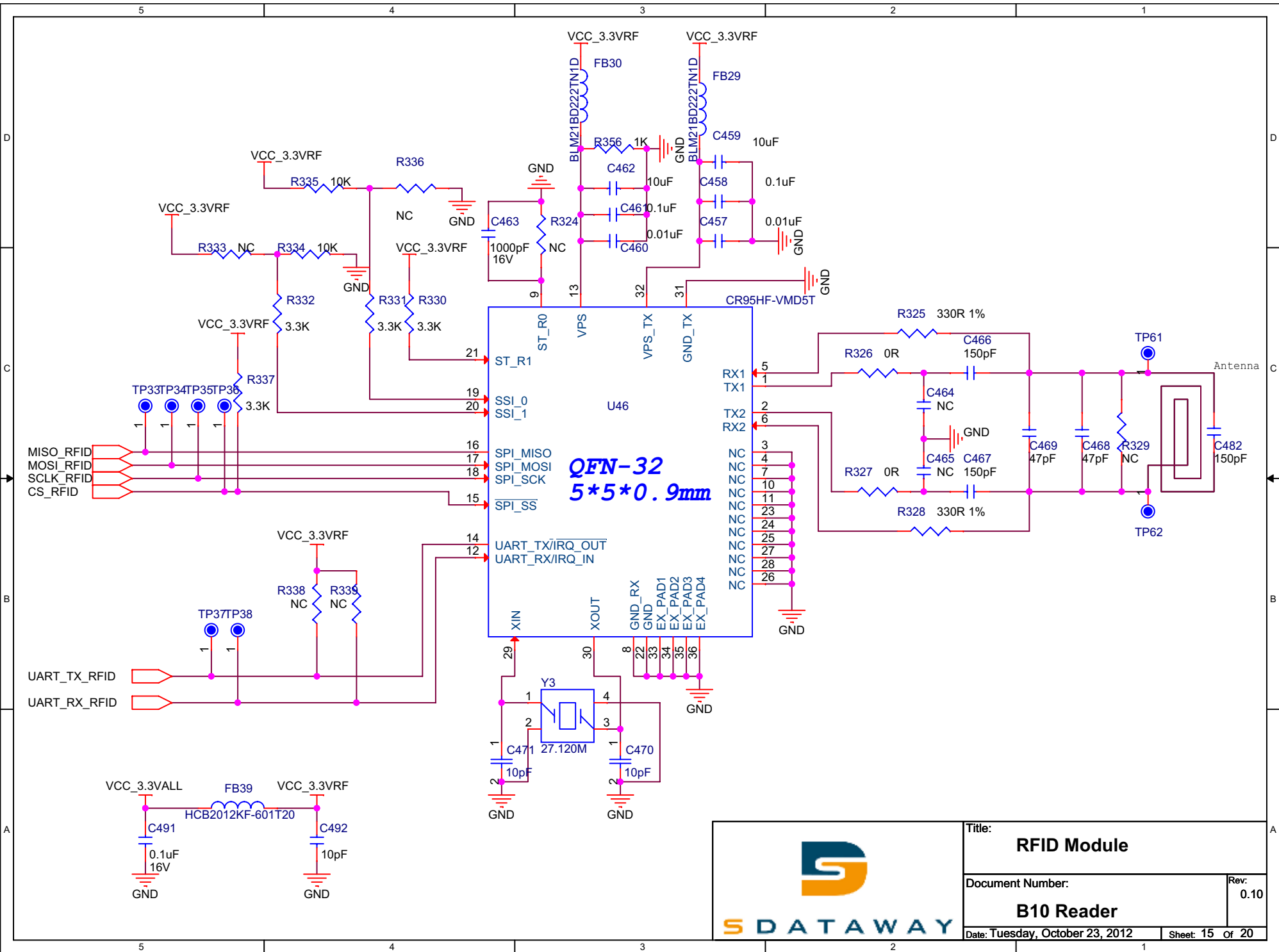

Title:		<b>RFID Module</b>
Document Number:		<b>B10 Reader</b>
Date: Tuesday, October 23, 2012		Rev: 0.10
Sheet: 15		of 20

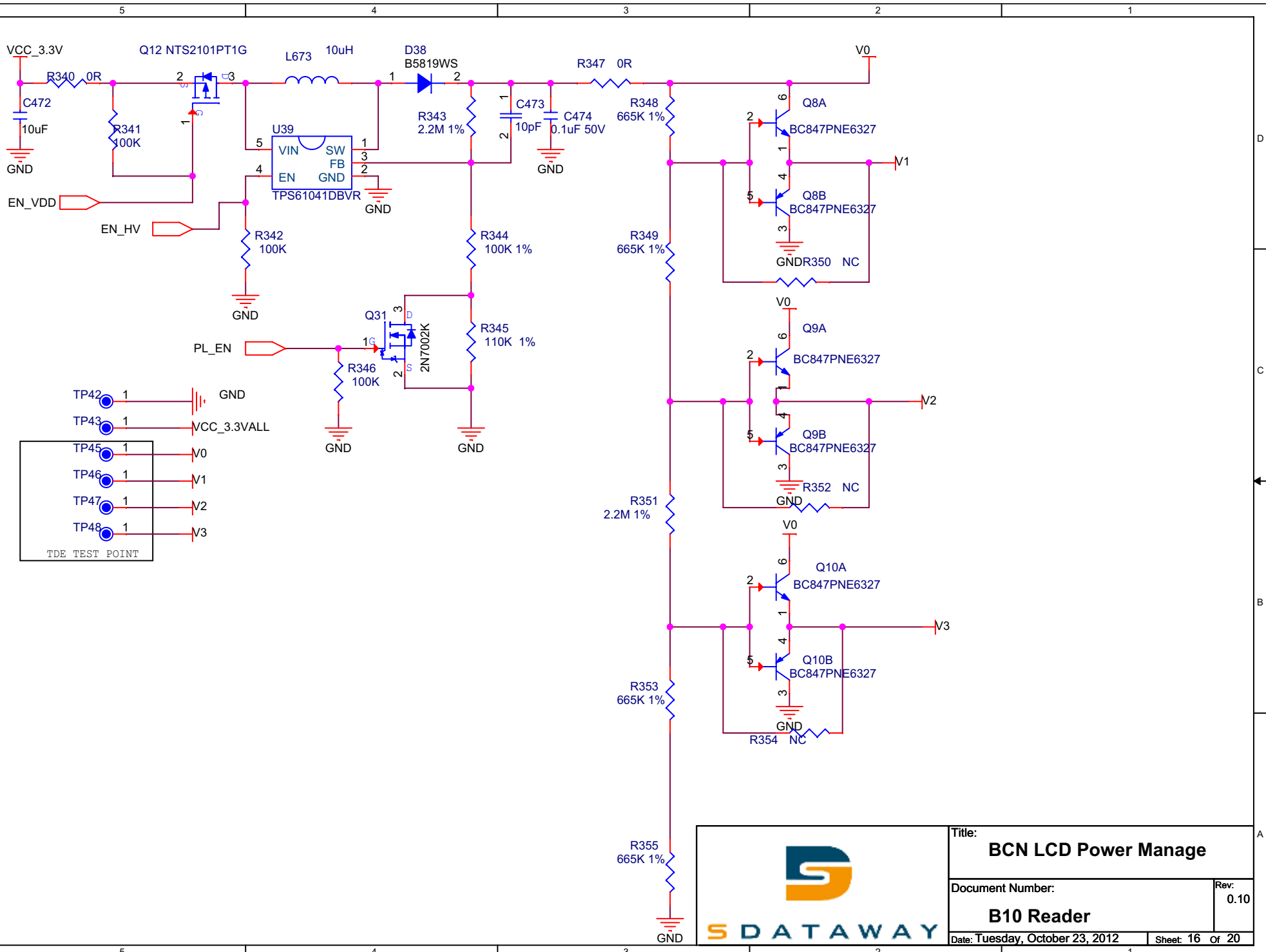

Title: <b>BCN LCD Power Manage</b>	
Document Number:	Rev: 0.10
<b>B10 Reader</b>	
Date: Tuesday, October 23, 2012	Sheet: 16 of 20



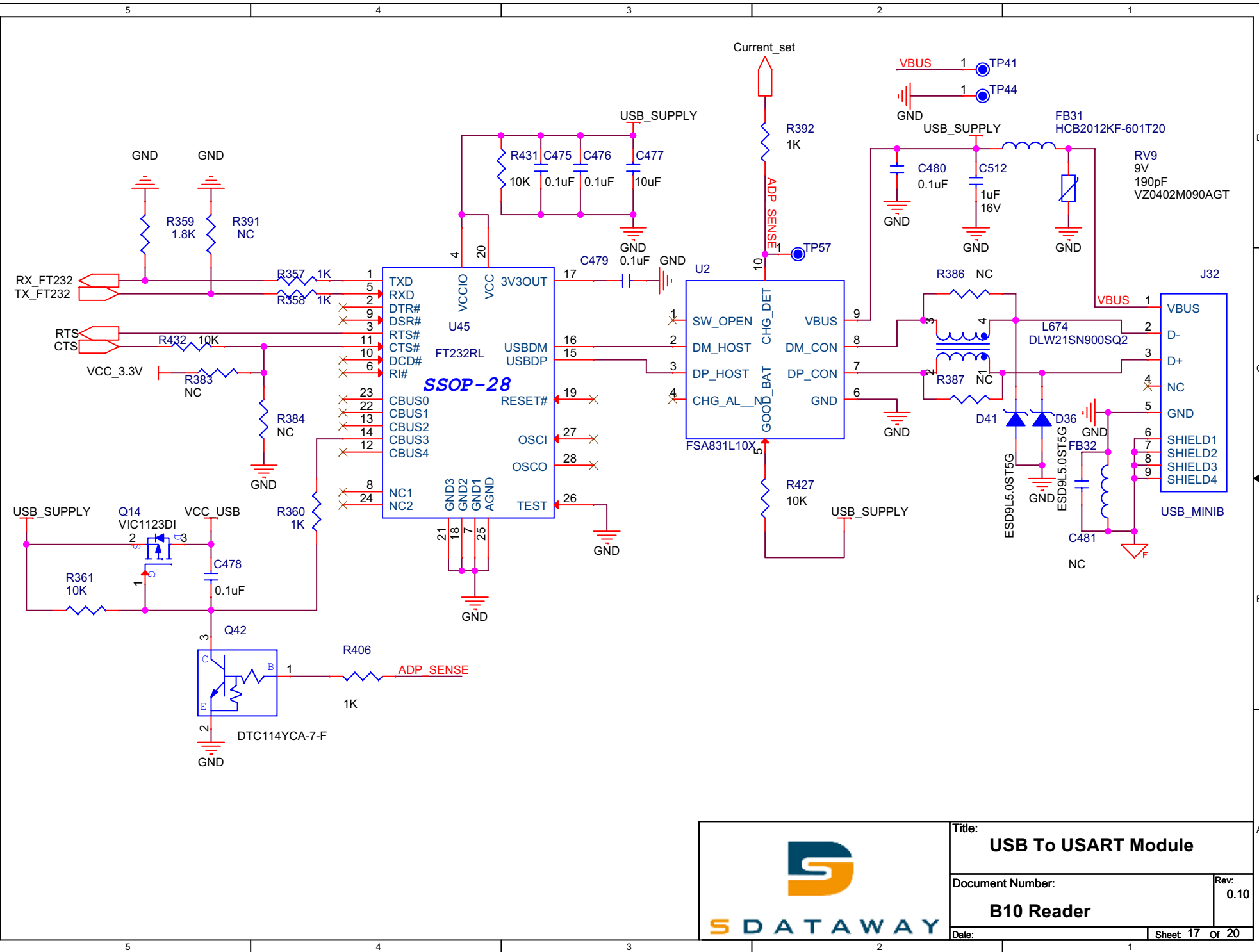

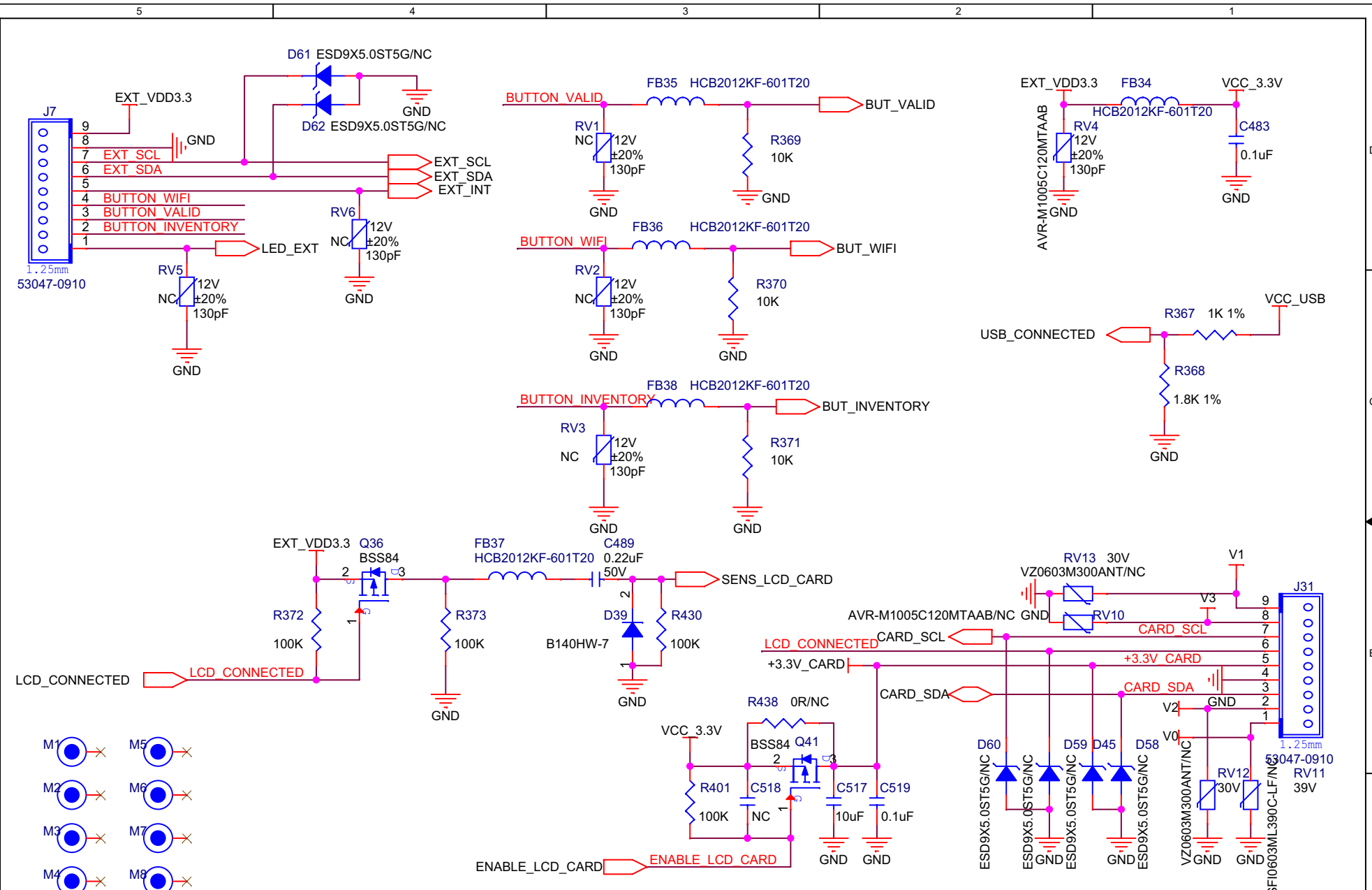

Title: <b>USB To USART Module</b>	
Document Number: <b>B10 Reader</b>	Rev: 0.10
Date:	Sheet: 17 of 20

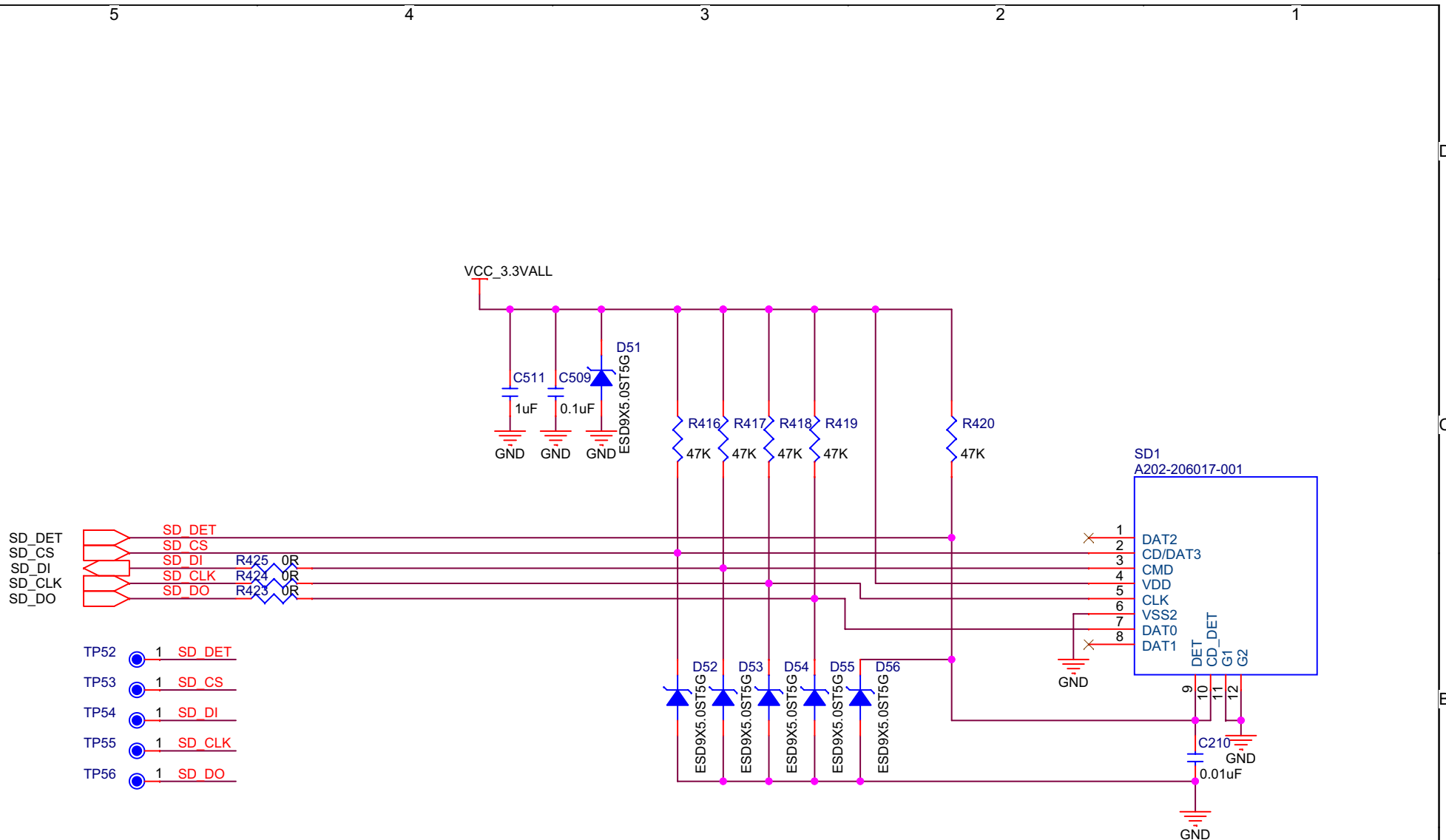

Title: <b>Key Press Control Module</b>	
Document Number: <b>B10 Reader</b>	Rev: 0.10
Date: Tuesday, October 23, 2012	Sheet: 18 of 20



	Title: TF CARD MODULE	
	Document Number: B10 Reader	Rev: 0.10
Date: Tuesday, October 23, 2012		Sheet: 19 of 20