



MET Laboratories, Inc. *Safety Certification - EMI - Telecom Environmental Simulation*

914 WEST PATAPSCO AVENUE ● BALTIMORE, MARYLAND 21230-3432 ● PHONE (410) 354-3300 ● FAX (410) 354-3313

March 23, 2011

Fiber-Span
3434 Rt. 22 W. Suite 140
Branchburg, New Jersey 08876

Dear David Thomson,

Enclosed is the EMC Wireless test report for compliance testing of the Fiber-Span, FS42R-PCS-5 as tested to the requirements of the FCC Certification rules under Title 47 of the CFR Part 24 Subpart E and RSS-133, Issue 5, February 2009 for Broadband PCS Devices and Part 15 Subpart B and ICES-003, Issue 4 February 2004 for Class A Digital Devices.

Thank you for using the services of MET Laboratories, Inc. If you have any questions regarding these results or if MET can be of further service to you, please contact me.

Sincerely yours,
MET LABORATORIES, INC.

Jennifer Warnell
Documentation Department

Reference: (\Fiber-Span\EMC30864F-FCC24 Rev. 1)

Certificates and reports shall not be reproduced except in full, without the written permission of MET Laboratories, Inc.



MET Laboratories, Inc. *Safety Certification - EMI - Telecom Environmental Simulation*

914 WEST PATAPSCO AVENUE ● BALTIMORE, MARYLAND 21230-3432 ● PHONE (410) 354-3300 ● FAX (410) 354-3313

Electromagnetic Compatibility Criteria Test Report

for the

**Fiber-Span
Model FS42R-PCS-5**

**Tested under
FCC Certification Rules
Title 47 of the CFR, Part 24 Subpart E & RSS-133, Issue 5, February 2009
for Broadband PCS Devices
and Part 15 Subpart B & ICES-003 for Class A Digital Devices**

MET Report: EMC30864F-FCC24 Rev. 1

March 23, 2011

Prepared For:

**Fiber-Span
3434 Rt. 22 W. Suite 140
Branchburg, New Jersey 08876**

**Prepared By:
MET Laboratories, Inc.
914 W. Patapsco Ave
Baltimore, MD 21230**

**Electromagnetic Compatibility Criteria
Test Report**

for the

**Fiber-Span
Model FS42R-PCS-5**

Tested Under

**FCC Certification Rules
Title 47 of the CFR, Part 24 Subpart E & RSS-133, Issue 5, February 2009
for Broadband PCS Devices
and Part 15 Subpart B & ICES-003 for Class A Digital Devices**

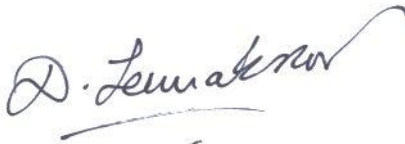

Dusmantha Tennakoon
Electromagnetic Compatibility Lab



Jennifer Warnell
Documentation Department

Engineering Statement: The measurements shown in this report were made in accordance with the procedures indicated, and the emissions from this equipment were found to be within the limits applicable. I assume full responsibility for the accuracy and completeness of these measurements, and for the qualifications of all persons taking them. It is further stated that upon the basis of the measurements made, the equipment tested is capable of operation in accordance with the requirements of Part 24 Subpart E and Part 15 Subpart B of the FCC Rules and Industry Canada standards ICES-003, Issue 4 February 2004, RSS-133, Issue 5, February 2009 under normal use and maintenance.



Shawn McMillen, Wireless Manager
Electromagnetic Compatibility Lab

Report Status Sheet

Revision	Report Date	Reason for Revision
∅	March 7, 2011	Initial Issue.
1	March 23, 2011	Revised to reflect correct EUT name and add FCC ID.

Table of Contents

I.	Executive Summary	1
A.	Purpose of Test	2
B.	Executive Summary	2
II.	Equipment Configuration	3
A.	Overview.....	4
B.	References.....	5
C.	Test Site	5
D.	Description of Test Sample.....	5
E.	Equipment Configuration.....	6
F.	Support Equipment	6
G.	Ports and Cabling Information.....	7
H.	Mode of Operation.....	7
I.	Modifications	7
	Modifications to EUT	7
	Modifications to Test Standard.....	7
J.	Disposition of EUT.....	7
III.	Electromagnetic Compatibility Criteria for Unintentional Radiators	8
	§ 15.107(a) Conducted Emissions Limits.....	9
	§ 15.109(a) Radiated Emission Limits	13
IV.	Electromagnetic Compatibility Criteria for Intentional Radiators.....	17
	§ 2.1046 RF Power Output.....	18
	§ 2.1049 Occupied Bandwidth	33
	§ 2.1053 Radiated Spurious Emissions	47
	§ 2.1051 Spurious Emissions at Antenna Terminals	51
	Frequency Stability.....	64
	RSS-GEN Receiver Spurious Emissions.....	65
	Intermodulation	66
	Filter Response	70
V.	Test Equipment	71
VI.	Certification & User’s Manual Information.....	73
A.	Certification Information	74
B.	Label and User’s Manual Information	78
VII.	ICES-003 Procedural & Labeling Requirements.....	80

List of Tables

Table 1. Executive Summary of EMC Compliance Testing	2
Table 2. EUT Summary Table.....	4
Table 3. Standard References	5
Table 4. Equipment Configuration	6
Table 5. Support Equipment (Radiated Emissions).....	6
Table 6. Ports and Cabling Information	7
Table 7. Conducted Limits for Radio Frequency Devices calculated from FCC Part 15 Section 15.107(a) (b)	9
Table 8. Conducted Emissions - Voltage, AC Power, Phase Line (120 VAC, 60 Hz).....	10
Table 9. Conducted Emissions - Voltage, AC Power, Neutral Line (120 VAC, 60 Hz)	11
Table 10. Radiated Emissions Limits calculated from FCC Part 15, §15.109 (a) (b)	13
Table 11. Radiated Emissions Limits, Test Results, FCC Limits.....	14
Table 12. Radiated Emissions Limits, Test Results, ICES-003 Limits	15
Table 13. RF Output Power, Test Results	19
Table 14. Spurious Emission Limits for Receivers	65
Table 15. Test Equipment List	72

List of Figures

Figure 1. Block Diagram of Test Configuration.....	6
--	---

List of Plots

Plot 1. Conducted Emissions, Phase Line	10
Plot 2. Conducted Emissions, Neutral Line.....	11
Plot 3. Radiated Emissions, Pre-Scan, FCC Limits	14
Plot 4. Radiated Emissions, Pre-Scan, ICES-003 Limits	15
Plot 5. 1930.67 MHz, RF Power Output, Downlink, EVDO, Average	20
Plot 6. 1930.67 MHz, RF Power Output, Downlink, EVDO, Peak	20
Plot 7. 1962 MHz, RF Power Output, Downlink, EVDO, Average	20
Plot 8. 1962 MHz, RF Power Output, Downlink, EVDO, Peak	21
Plot 9. 1994.33 MHz, RF Power Output, Downlink, EVDO, Average	21
Plot 10. 1994.33 MHz, RF Power Output, Downlink, EVDO, Peak	21
Plot 11. 1930.7 MHz, RF Power Output, Downlink, LTE, Average	22
Plot 12. 1930.7 MHz, RF Power Output, Downlink, LTE, Peak	22
Plot 13. 1962 MHz, RF Power Output, Downlink, LTE, Average	22
Plot 14. 1962 MHz, RF Power Output, Downlink, LTE, Peak	23
Plot 15. 1994.3 MHz, RF Power Output, Downlink, LTE, Average	23
Plot 16. 1994.3 MHz, RF Power Output, Downlink, LTE, Peak	23
Plot 17. 1930.125 MHz, RF Power Output, Downlink, GSM, Average	24
Plot 18. 1930.125 MHz, RF Power Output, Downlink, GSM, Peak	24
Plot 19. 1962 MHz, RF Power Output, Downlink, GSM, Average	24
Plot 20. 1962 MHz, RF Power Output, Downlink, GSM, Peak	25
Plot 21. 1994.875 MHz, RF Power Output, Downlink, GSM, Average	25
Plot 22. 1994.875 MHz, RF Power Output, Downlink, GSM, Peak	25
Plot 23. 1850.67 MHz, RF Power Output, Uplink, EVDO, Average	26
Plot 24. 1850.67 MHz, RF Power Output, Uplink, EVDO, Peak	26
Plot 25. 1885 MHz, RF Power Output, Uplink, EVDO, Average	26
Plot 26. 1885 MHz, RF Power Output, Uplink, EVDO, Peak	27
Plot 27. 1944.33 MHz, RF Power Output, Uplink, EVDO, Average	27
Plot 28. 1944.33 MHz, RF Power Output, Uplink, EVDO, Peak	27
Plot 29. 1850.7 MHz, RF Power Output, Uplink, LTE, Average	28
Plot 30. 1850.7 MHz, RF Power Output, Uplink, LTE, Peak	28

Plot 31. 1885 MHz, RF Power Output, Uplink, LTE, Average.....	28
Plot 32. 1885 MHz, RF Power Output, Uplink, LTE, Peak	29
Plot 33. 1914.3 MHz, RF Power Output, Uplink, LTE, Average.....	29
Plot 34. 1914.3 MHz, RF Power Output, Uplink, LTE, Peak	29
Plot 35. 1950.125 MHz, RF Power Output, Uplink, GSM, Average	30
Plot 36. 1950.125 MHz, RF Power Output, Uplink, GSM, Peak	30
Plot 37. 1885 MHz, RF Power Output, Uplink, GSM, Average	30
Plot 38. 1885 MHz, RF Power Output, Uplink, GSM, Peak	31
Plot 39. 1914.875 MHz, RF Power Output, Uplink, GSM, Average	31
Plot 40. 1914.875 MHz, RF Power Output, Uplink, GSM, Peak	31
Plot 41. 1930.67 MHz, Occupied Bandwidth, Downlink, EVDO, In.....	34
Plot 42. 1930.67 MHz, Occupied Bandwidth, Downlink, EVDO, Out.....	34
Plot 43. 1962 MHz, Occupied Bandwidth, Downlink, EVDO, In	34
Plot 44. 1962 MHz, Occupied Bandwidth, Downlink, EVDO, Out.....	35
Plot 45. 1994.33 MHz, Occupied Bandwidth, Downlink, EVDO, In.....	35
Plot 46. 1994.33 MHz, Occupied Bandwidth, Downlink, EVDO, Out.....	35
Plot 47. 1930.7 MHz, Occupied Bandwidth, Downlink, LTE, In	36
Plot 48. 1930.7 MHz, Occupied Bandwidth, Downlink, LTE, Out.....	36
Plot 49. 1962 MHz, Occupied Bandwidth, Downlink, LTE, In	36
Plot 50. 1962 MHz, Occupied Bandwidth, Downlink, LTE, Out.....	37
Plot 51. 1994.3 MHz, Occupied Bandwidth, Downlink, LTE, In	37
Plot 52. 1994.3 MHz, Occupied Bandwidth, Downlink, LTE, Out.....	37
Plot 53. 1930.125 MHz, Occupied Bandwidth, Downlink, GSM, In.....	38
Plot 54. 1930.125 MHz, Occupied Bandwidth, Downlink, GSM, Out	38
Plot 55. 1962 MHz, Occupied Bandwidth, Downlink, GSM, In.....	38
Plot 56. 1962 MHz, Occupied Bandwidth, Downlink, GSM, Out	39
Plot 57. 1994.875 MHz, Occupied Bandwidth, Downlink, GSM, In.....	39
Plot 58. 1994.875 MHz, Occupied Bandwidth, Downlink, GSM, Out	39
Plot 59. 1850.67 MHz, Occupied Bandwidth, Uplink, EVDO, In	40
Plot 60. 1850.67 MHz, Occupied Bandwidth, Uplink, EVDO, Out.....	40
Plot 61. 1885 MHz, Occupied Bandwidth, Uplink, EVDO, In	40
Plot 62. 1885 MHz, Occupied Bandwidth, Uplink, EVDO, Out.....	41
Plot 63. 1914.33 MHz, Occupied Bandwidth, Uplink, EVDO, In	41
Plot 64. 1914.33 MHz, Occupied Bandwidth, Uplink, EVDO, Out.....	41
Plot 65. 1850.7 MHz, Occupied Bandwidth, Uplink, LTE, In	42
Plot 66. 1850.7 MHz, Occupied Bandwidth, Uplink, LTE, Out	42
Plot 67. 1885 MHz, Occupied Bandwidth, Uplink, LTE, In	42
Plot 68. 1885 MHz, Occupied Bandwidth, Uplink, LTE, Out	43
Plot 69. 1914.3 MHz, Occupied Bandwidth, Uplink, LTE, In	43
Plot 70. 1914.3 MHz, Occupied Bandwidth, Uplink, LTE, Out	43
Plot 71. 1850.125 MHz, Occupied Bandwidth, Uplink, GSM, In.....	44
Plot 72. 1850.125 MHz, Occupied Bandwidth, Uplink, GSM, Out	44
Plot 73. 1885 MHz, Occupied Bandwidth, Uplink, GSM, In.....	44
Plot 74. 1885 MHz, Occupied Bandwidth, Uplink, GSM, Out	45
Plot 75. 1914.875 MHz, Occupied Bandwidth, Uplink, GSM, In.....	45
Plot 76. 1914.875 MHz, Occupied Bandwidth, Uplink, GSM, Out	45
Plot 77. 1930.67 MHz, Radiated Spurious Emissions, Downlink, 30 MHz – 1 GHz	48
Plot 78. 1930.67 MHz, Radiated Spurious Emissions, Downlink, 1 GHz – 18 GHz.....	48
Plot 79. 1962 MHz, Radiated Spurious Emissions, Downlink, 30 MHz – 1 GHz	48
Plot 80. 1962 MHz, Radiated Spurious Emissions, Downlink, 1 GHz – 18 GHz.....	49
Plot 81. 1994.33 MHz, Radiated Spurious Emissions, Downlink, 30 MHz – 1 GHz	49
Plot 82. 1994.33 MHz, Radiated Spurious Emissions, Downlink, 1 GHz – 18 GHz	49
Plot 83. 1930.67 MHz, Conducted Spurious Emissions, Downlink, EVDO, 30 MHz – 1 GHz	52
Plot 84. 1930.67 MHz, Conducted Spurious Emissions, Downlink, EVDO, 1 GHz – 2.5 GHz.....	52
Plot 85. 1930.67 MHz, Conducted Spurious Emissions, Downlink, EVDO, 2.5 GHz – 20 GHz.....	52

Plot 86. 1962 MHz, Conducted Spurious Emissions, Downlink, EVDO, 30 MHz – 1 GHz	53
Plot 87. 1962 MHz, Conducted Spurious Emissions, Downlink, EVDO, 1 GHz – 2.5 GHz	53
Plot 88. 1962 MHz, Conducted Spurious Emissions, Downlink, EVDO, 2.5 GHz – 20 GHz	53
Plot 89. 1994.33 MHz, Conducted Spurious Emissions, Downlink, EVDO, 30 MHz – 1 GHz	54
Plot 90. 1994.33 MHz, Conducted Spurious Emissions, Downlink, EVDO, 1 GHz – 2.5 GHz	54
Plot 91. 1994.33 MHz, Conducted Spurious Emissions, Downlink, EVDO, 2.5 GHz – 20 GHz	54
Plot 92. 1930.7 MHz, Conducted Spurious Emissions, Downlink, LTE, 30 MHz – 1 GHz	55
Plot 93. 1930.7 MHz, Conducted Spurious Emissions, Downlink, LTE, 1 GHz – 2.5 GHz	55
Plot 94. 1930.7 MHz, Conducted Spurious Emissions, Downlink, LTE, 2.5 GHz – 20 GHz	55
Plot 95. 1962 MHz, Conducted Spurious Emissions, Downlink, LTE, 30 MHz – 1 GHz	56
Plot 96. 1962 MHz, Conducted Spurious Emissions, Downlink, LTE, 1 GHz – 2.5 GHz	56
Plot 97. 1962 MHz, Conducted Spurious Emissions, Downlink, LTE, 2.5 GHz – 20 GHz	56
Plot 98. 1994.3 MHz, Conducted Spurious Emissions, Downlink, LTE, 30 MHz – 1 GHz	57
Plot 99. 1994.3 MHz, Conducted Spurious Emissions, Downlink, LTE, 1 GHz – 2.5 GHz	57
Plot 100. 1994.3 MHz, Conducted Spurious Emissions, Downlink, LTE, 2.5 GHz – 20 GHz	57
Plot 101. 1930.125 MHz, Conducted Spurious Emissions, Downlink, GSM, 30 MHz – 1 GHz	58
Plot 102. 1930.125 MHz, Conducted Spurious Emissions, Downlink, GSM, 1 GHz – 2.5 GHz	58
Plot 103. 1930.125 MHz, Conducted Spurious Emissions, Downlink, GSM, 2.5 GHz – 20 GHz	58
Plot 104. 1962 MHz, Conducted Spurious Emissions, Downlink, GSM, 30 MHz – 1 GHz	59
Plot 105. 1962 MHz, Conducted Spurious Emissions, Downlink, GSM, 1 GHz – 2.5 GHz	59
Plot 106. 1962 MHz, Conducted Spurious Emissions, Downlink, GSM, 2.5 GHz – 20 GHz	59
Plot 107. 1994.875 MHz, Conducted Spurious Emissions, Downlink, GSM, 30 MHz – 1 GHz	60
Plot 108. 1994.875 MHz, Conducted Spurious Emissions, Downlink, GSM, 1 GHz – 2.5 GHz	60
Plot 109. 1994.875 MHz, Conducted Spurious Emissions, Downlink, GSM, 2.5 GHz – 20 GHz	60
Plot 110. 1950.67 MHz, Conducted Spurious Emissions, Uplink, EVDO, 30 MHz – 20 GHz	61
Plot 111. 1885 MHz, Conducted Spurious Emissions, Uplink, EVDO, 30 MHz – 20 GHz	61
Plot 112. 1914.33 MHz, Conducted Spurious Emissions, Uplink, EVDO, 30 MHz – 20 GHz	61
Plot 113. 1950.7 MHz, Conducted Spurious Emissions, Uplink, LTE, 30 MHz – 20 GHz	62
Plot 114. 1885 MHz, Conducted Spurious Emissions, Uplink, LTE, 30 MHz – 20 GHz	62
Plot 115. 1914.3 MHz, Conducted Spurious Emissions, Uplink, LTE, 30 MHz – 20 GHz	62
Plot 116. 1950.125 MHz, Conducted Spurious Emissions, Uplink, GSM, 30 MHz – 20 GHz	63
Plot 117. 1885 MHz, Conducted Spurious Emissions, Uplink, GSM, 30 MHz – 20 GHz	63
Plot 118. 1914.875 MHz, Conducted Spurious Emissions, Uplink, GSM, 30 MHz – 20 GHz	63
Plot 119. Intermodulation, Downlink, EVDO, Low Channel	66
Plot 120. Intermodulation, Downlink, EVDO, High Channel	66
Plot 121. Intermodulation, Downlink, LTE, Low Channel	66
Plot 122. Intermodulation, Downlink, LTE, High Channel	67
Plot 123. Intermodulation, Downlink, GSM, Low Channel	67
Plot 124. Intermodulation, Downlink, GSM, High Channel	67
Plot 125. Intermodulation, Uplink, EVDO, Low Channel	68
Plot 126. Intermodulation, Uplink, EVDO, High Channel	68
Plot 127. Intermodulation, Uplink, LTE, Low Channel	68
Plot 128. Intermodulation, Uplink, LTE, High Channel	69
Plot 129. Intermodulation, Uplink, GSM, Low Channel	69
Plot 130. Intermodulation, Uplink, GSM, High Channel	69
Plot 131. Filter Response, Downlink	70
Plot 132. Filter Response, Uplink	70

List of Photographs

Photograph 1. Conducted Emissions, Test Setup	12
Photograph 2. Radiated Emission Limits, Test Setup	16
Photograph 3. RF Power, Test Setup.....	32
Photograph 4. Occupied Bandwidth, Test Setup.....	46
Photograph 5. Radiated Spurious, Test Setup, Above 1 GHz	50

List of Terms and Abbreviations

AC	Alternating Current
ACF	Antenna Correction Factor
Cal	Calibration
<i>d</i>	Measurement Distance
dB	Decibels
dB μ A	Decibels above one microamp
dB μ V	Decibels above one microvolt
dB μ A/m	Decibels above one microamp per meter
dB μ V/m	Decibels above one microvolt per meter
DC	Direct Current
E	Electric Field
DSL	Digital Subscriber Line
ESD	Electrostatic Discharge
EUT	Equipment Under Test
<i>f</i>	Frequency
FCC	Federal Communications Commission
GRP	Ground Reference Plane
H	Magnetic Field
HCP	Horizontal Coupling Plane
Hz	Hertz
IEC	International Electrotechnical Commission
kHz	kilohertz
kPa	kilopascal
kV	kilovolt
LISN	Line Impedance Stabilization Network
MHz	Megahertz
μ H	microhenry
μ F	microfarad
μ s	microseconds
NEBS	Network Equipment-Building System
PRF	Pulse Repetition Frequency
RF	Radio Frequency
RMS	Root-Mean-Square
TWT	Traveling Wave Tube
V/m	Volts per meter
VCP	Vertical Coupling Plane

I. Executive Summary

A. Purpose of Test

An EMC evaluation was performed to determine compliance of the Fiber-Span FS42R-PCS-5, with the requirements of Part 24 Subpart E and Part 15 Subpart B. All references are to the most current version of Title 47 of the Code of Federal Regulations in effect. In accordance with §2.1033, the following data is presented in support of the Certification of the FS42R-PCS-5. Fiber-Span should retain a copy of this document which should be kept on file for at least two years after the manufacturing of the FS42R-PCS-5, has been **permanently** discontinued.

B. Executive Summary

The following tests were conducted on a sample of the equipment for the purpose of demonstrating compliance with Part 24 Subpart E and Part 15 Subpart B, in accordance with Fiber-Span, purchase order number 5861.

FCC Reference	IC Reference	Description	Compliance
Part 15 Subpart B §15.109(a)	ICES-003 Issue 4 February 2004	Conducted Emissions	Compliant
Part 15 Subpart B §15.107(a)	ICES-003 Issue 4 February 2004	Radiated Emissions	Compliant
§2.1046; §24.232	RSS-133, Section 6.4	RF Power Output	Compliant
§2.1047	RSS-133, Section 6.2	Modulation Characteristics	Not Applicable
§2.1049	RSS-GEN, Section 4.6.1	Occupied Bandwidth	Compliant
§2.1051; §24.238	RSS-133, Section 6.5	Conducted Spurious Emissions at Antenna Terminals	Compliant
§2.1053; §24.238	RSS-133, Section 6.5	Radiated Spurious Emissions from the Cabinet	Compliant
§2.1055; §24.135	RSS-133, Section 6.3	Frequency Stability	Not Applicable
N/A	RSS-GEN, Section 6	Receiver Spurious Emissions	Compliant
		Filter Response	Compliant
		Intermodulation	Compliant

Table 1. Executive Summary of EMC Compliance Testing

II. Equipment Configuration

A. Overview

MET Laboratories, Inc. was contracted by Fiber-Span to perform testing on the FS42R-PCS-5, under Fiber-Span's purchase order number 5861.

This document describes the test setups, test methods, required test equipment, and the test limit criteria used to perform compliance testing of the Fiber-Span, FS42R-PCS-5.

The results obtained relate only to the item(s) tested.

Model(s) Tested:	FS42R-PCS-5				
EUT Specifications:	Primary Power: 120 VAC, 60 Hz				
	FCC ID: Q4VFS42R-PCS-5				
	Type of Modulations:	EVDO, LTE, GSM			
	Equipment Code:	TNB			
	Avg. RF Output Power:	Down Link		Up Link	
		EVDO	0.789 W	EVDO	0.000042 W
		LTE	0.740 W	LTE	0.00010 W
	EUT Frequency Range:	GSM	0.552 W	GSM	0.00012 W
		Down Link (MHz)		Up Link (MHz)	
		EVDO	1930.67-1994.33	EVDO	1850.67-1914.33
LTE	1930.70-1994.30	LTE	1850.7-1914.3		
GSM	1930.125-1994.875	GSM	1850.125-1914.875		
Analysis:	The results obtained relate only to the item(s) tested.				
Environmental Test Conditions:	Temperature: 15-35° C				
	Relative Humidity: 30-60%				
	Barometric Pressure: 860-1060 mbar				
Evaluated by:	Dusmantha Tennakoon				
Date(s):	March 23, 2011				

Table 2. EUT Summary Table

B. References

CFR 47, Part 24, Subpart E	Federal Communication Commission, Code of Federal Regulations, Title 47, Part 24: Rules and Regulations for Personal Communications Services
CFR 47, Part 15, Subpart B	Electromagnetic Compatibility: Criteria for Radio Frequency Devices
RSS-133, Issue 5, February 2009	2 GHz Personal Communications Services
ANSI C63.4:2003	Methods and Measurements of Radio-Noise Emissions from Low-Voltage Electrical And Electronic Equipment in the Range of 9 kHz to 40 GHz
ANSI/NCSL Z540-1-1994	Calibration Laboratories and Measuring and Test Equipment - General Requirements
ANSI/ISO/IEC 17025:2000	General Requirements for the Competence of Testing and Calibration Laboratories
EIA/TIA-603-A-2001	Land Mobile FM or PM Communication Equipment Measurement and Performance Standards

Table 3. Standard References

C. Test Site

All testing was performed at MET Laboratories, Inc., 914 West Patapsco Ave, Baltimore, MD 21230. All equipment used in making physical determinations is accurate and bears recent traceability to the National Institute of Standards and Technology.

Radiated Emissions measurements were performed in a 3 meter semi-anechoic chamber (equivalent to an Open Area Test Site).

D. Description of Test Sample

The EUT is a FS42R-PCS-5. This module is part of the RFN system. The RFN has three (3) antenna ports. The RF from the iDEN module is split between the 3 ports as follows:

1. Antenna port 1: full power
2. Antenna port 2: full power – 6 dB
3. Antenna port 3: full power

The Fiber-Span Remote Fiber Node (RFN), model FS47R consists of a chassis mainframe with up to six (6) optional plug-in service modules. Each Service Module provides dedicated support for one of the following wireless services:

- 700 MHz commercial band
- 800/900 MHz iDEN
- 850 MHz Cellular
- 1.9GHz PCS
- 2.1GHz AWS
- GHz WiFi

A seventh module (shown in the attached block diagram) will be available for future WiMAX support.

The RFN is intended for use with associated Headend equipment, including the FTU-RF, and RIS units which provide the necessary signal feed for all wireless services via optical fiber.

The RFN and associated Headend Equipment are intended to provide, via optical fiber links, a means of extending the reach of a Wireless Service Provider's BTS to areas otherwise obscured from their signal, such as subways, underground shopping areas, etc.

The output of the RFN is common to all Service Modules, and terminates in three antenna ports. Except for signal level, all signals appear at all three ports.

Operation is bi-directional in nature, and varies somewhat, depending on the requirements of the particular technology supported by the specific plug-in Service Module.

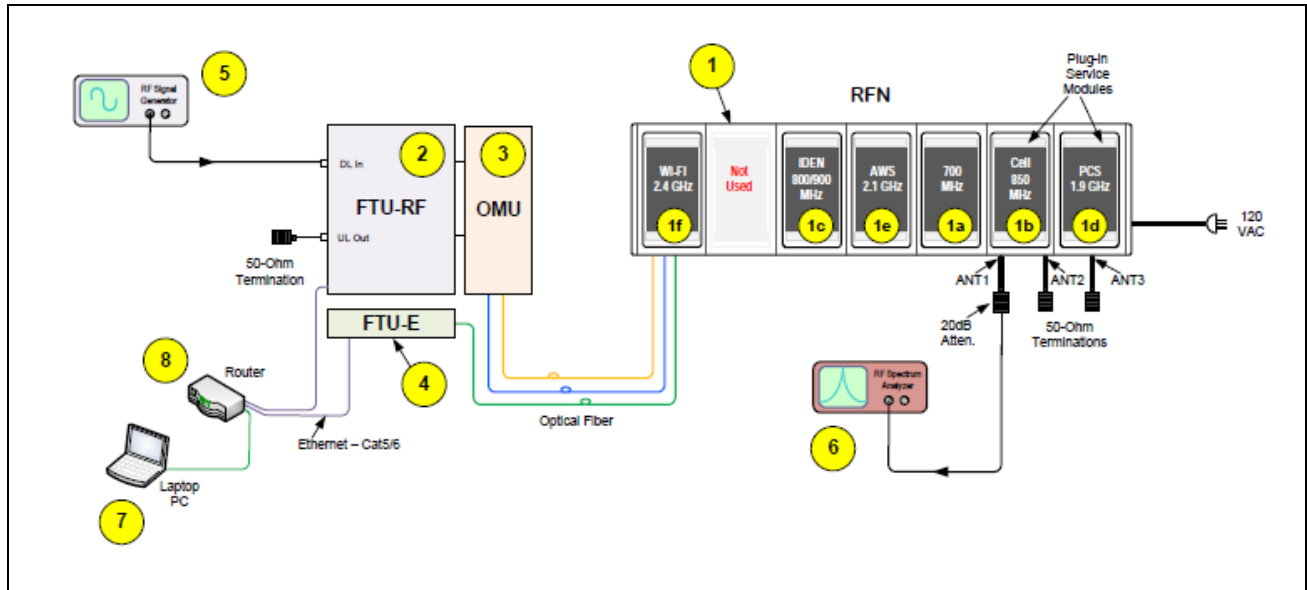

Figure 1. Block Diagram of Test Configuration

E. Equipment Configuration

Ref. ID	Name / Description	Model Number	Serial Number
1d	Service Module, PCS, 5W, SBY	FS42R - PCS - 5	2656 - 02

Table 4. Equipment Configuration

F. Support Equipment

Ref. ID	Name / Description	Manufacturer	Model Number	Serial Number
2	FTU - RF	Fiber - Span	N/A	2656 - 20
3	OMU	Fiber - Span	N/A	2656 - 27
4	FTU - E	IMC Networks	856 - 1047	N/A
7	Laptop PC (w/CAN Tools S/W)	N/A	N/A	N/A
8	Router	N/A	N/A	N/A

Table 5. Support Equipment (Radiated Emissions)

G. Ports and Cabling Information

Ref. ID	Port Name on EUT	Cable Description	Qty.	Length (m)	Shielded (Y/N)	Termination Point
1	ANT 1	RF Coaxial cable	1	1	Y	6
1	ANT 2	50 - Ohm Termination	1	N/A	Y	N/A
1	ANT 3	50 - Ohm Termination	1	N/A	Y	N/A

Table 6. Ports and Cabling Information

H. Mode of Operation

RFN is normally connected to the associated Headend Equipment – the FTU-RF and RIS units, via optical fiber.

Each optional wireless service supported operates independently, and may be removed without affecting the others installed in the mainframe option chassis.

The RFN receives an RF input signal in the downlink direction from an associated BTS (normally supplied by Wireless Service Provider). This connection is made via coaxial cable and connector at the RIS unit.

I. Modifications

a) Modifications to EUT

No modifications were made to the EUT.

b) Modifications to Test Standard

No modifications were made to the test standard.

J. Disposition of EUT

The test sample including all support equipment submitted to the Electro-Magnetic Compatibility Lab for testing was returned to Fiber-Span upon completion of testing.

III. Electromagnetic Compatibility Criteria for Unintentional Radiators

Electromagnetic Compatibility Criteria for Unintentional Radiators

§ 15.107 Conducted Emissions Limits

Test Requirement(s): **15.107 (a)** “Except for Class A digital devices, for equipment that is designed to be connected to the public utility (AC) power line, the radio frequency voltage that is conducted back onto the AC power line on any frequency or frequencies within the band 150 kHz to 30 MHz shall not exceed the limits in Table 7. Compliance with this provision shall be based on the measurement of the radio frequency voltage between each power line and ground at the power terminals.”

15.107 (b) “For a Class A digital device that is designed to be connected to the public utility (AC) power line, the radio frequency voltage that is conducted back onto the AC power line on any frequency or frequencies within the band 150 kHz to 30 MHz shall not exceed the limits in Table 7. Compliance with this provision shall be based on the measurement of the radio frequency voltage between each power line and ground at the power terminals. The lower limit applies at the band edges.”

Frequency range (MHz)	15.107(b), Class A Limits (dBµV)		15.107(a), Class B Limits (dBµV)	
	Quasi-Peak	Average	Quasi-Peak	Average
0.15- 0.5	79	66	66 - 56	56 - 46
0.5 – 5.0	73	60	56	46
5.0 - 30	73	60	60	50

Note 1 — The lower limit shall apply at the transition frequencies.

Table 7. Conducted Limits for Radio Frequency Devices calculated from FCC Part 15 Section 15.107(a) (b)

Test Procedures: The EUT was place on a 0.8 m high wooden table inside a shielded room. The method of testing, test conditions, and test procedures of ANSI C63.4 were used. The EUT was powered through a 50Ω/50µH LISN. An EMI receiver, connected to the measurement port of the LISN, scanned the frequency range from 150 kHz to 30 MHz in order to find the peak conducted emissions. All peak emissions within 6 dB of the limit were measured using a quasi-peak and/or average detector as appropriate.

Test Results: The EUT was found compliant with the Class A requirement(s) of this section. Measured emissions were below applicable limits.

Test Engineer(s): Jeffrey Pratt

Test Date(s): 02/24/11

Conducted Emissions - Voltage, AC Power, Phase Line (120 VAC, 60 Hz)

Frequency (MHz)	Uncorrected Meter Reading (dBuV) QP	Cable Loss (dB)	Corrected Measurement (dBuV) QP	Limit (dBuV) QP	Margin (dB) QP	Uncorrected Meter Reading (dBuV) Avg.	Cable Loss (dB)	Corrected Measurement (dBuV) AVG	Limit (dBuV) AVG	Margin (dB) AVG
0.325	39.04	0	39.04	79	-39.96	35.08	0	35.08	66	-30.92
1.27	22.37	0	22.37	73	-50.63	19.83	0	19.83	60	-40.17
5.22	34.17	0.06	34.23	73	-38.77	29.51	0.06	29.57	60	-30.43
7.91	20.7	0	20.7	73	-52.3	13.56	0	13.56	60	-46.44
15.86	31.51	0	31.51	73	-41.49	18.16	0	18.16	60	-41.84
16.41	42.43	0	42.43	73	-30.57	39.17	0	39.17	60	-20.83

Table 8. Conducted Emissions - Voltage, AC Power, Phase Line (120 VAC, 60 Hz)

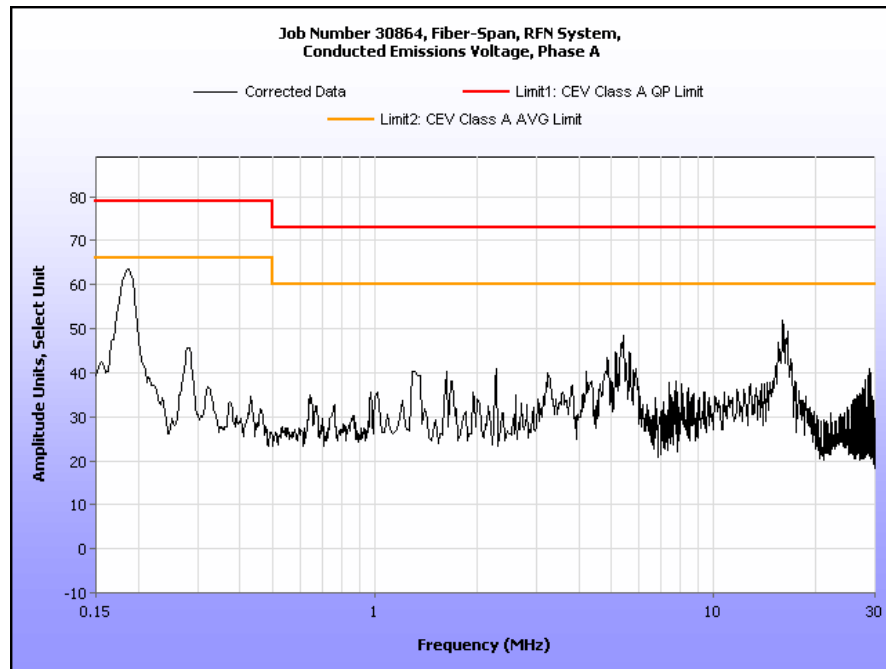

Plot 1. Conducted Emissions, Phase Line

Conducted Emissions - Voltage, AC Power, Neutral Line (120 VAC, 60 Hz)

Frequency (MHz)	Uncorrected Meter Reading (dBuV) QP	Cable Loss (dB)	Corrected Measurement (dBuV) QP	Limit (dBuV) QP	Margin (dB) QP	Uncorrected Meter Reading (dBuV) Avg.	Cable Loss (dB)	Corrected Measurement (dBuV) AVG	Limit (dBuV) AVG	Margin (dB) AVG
0.323	40.94	0	40.94	79	-38.06	38.59	0	38.59	66	-27.41
1.32	35.36	0	35.36	73	-37.64	32.94	0	32.94	60	-27.06
4.8	26.64	0.05	26.69	73	-46.31	20.34	0.05	20.39	60	-39.61
5.1	33.75	0.06	33.81	73	-39.19	22.88	0.06	22.94	60	-37.06
16.38	37.59	0	37.59	73	-35.41	23.8	0	23.8	60	-36.2
16.79	34.54	0	34.54	73	-38.46	21.49	0	21.49	60	-38.51

Table 9. Conducted Emissions - Voltage, AC Power, Neutral Line (120 VAC, 60 Hz)

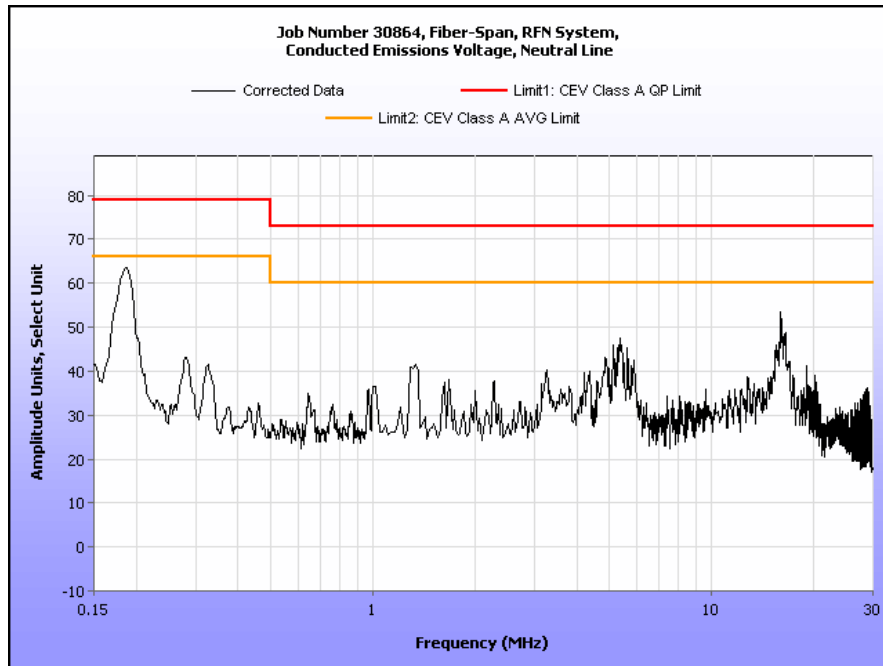

Plot 2. Conducted Emissions, Neutral Line

Conducted Emission Limits Test Setup

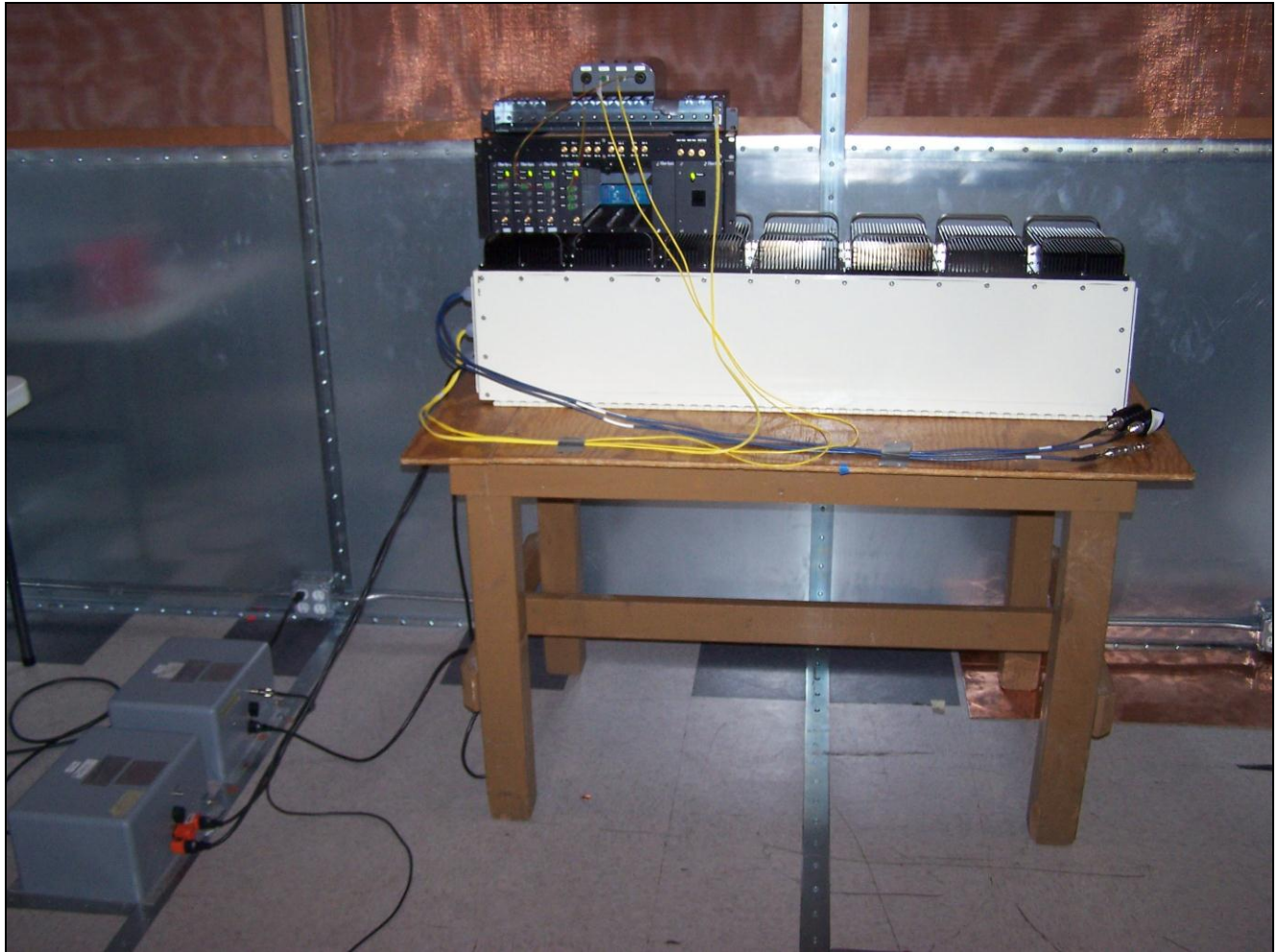

Photograph 1. Conducted Emissions, Test Setup

Radiated Emission Limits

Test Requirement(s): **15.109 (a)** Except for Class A digital devices, the field strength of radiated emissions from unintentional radiators at a distance of 3 meters shall not exceed the Class B limits expressed in Table 10.

15.109 (b) The field strength of radiated emissions from a Class A digital device, as determined at a distance of 10 meters, shall not exceed the Class A limits expressed in Table 10.

Frequency (MHz)	Field Strength (dB μ V/m)	
	§15.109 (b), Class A Limit (dB μ V) @ 10m	§15.109 (a), Class B Limit (dB μ V) @ 3m
30 - 88	39.00	40.00
88 - 216	43.50	43.50
216 - 960	46.40	46.00
Above 960	49.50	54.00

Table 10. Radiated Emissions Limits calculated from FCC Part 15, §15.109 (a) (b)

Test Procedures: The EUT was placed on a wooden stand inside a semi-anechoic chamber. The method of testing and test conditions of ANSI C63.4 were used. An antenna was located 3 m from the EUT on an adjustable mast. A pre-scan was first performed in order to find prominent radiated emissions. For final emissions measurements at each frequency of interest, the EUT was rotated and the antenna height was varied between 1 m and 4 m in order to maximize the emission. Measurements in both horizontal and vertical polarities were made and the data was recorded. Unless otherwise specified, measurements were made using a quasi-peak detector with a 120 kHz bandwidth.

Emissions measured at 3m were normalized using an inverse proportionality factor of 20 dB per decade for comparison to the 10 m limit.

Test Results: The EUT was found compliant with the Class A requirement(s) of this section. Measured emissions were below applicable limits

Test Engineer(s): Dusmantha Tennakoon

Test Date(s): 02/22/11

Radiated Emissions Limits Test Results, Class A

Frequency (MHz)	EUT Azimuth (Degrees)	Antenna Polarity (H/V)	Antenna HEIGHT (m)	Uncorrected Amplitude (dBuV)	Antenna Correction Factor (dB) (+)	Cable Loss (dB) (+)	Distance Correction Factor (dB) (-)	Corrected Amplitude (dBuV/m)	Limit (dBuV/m)	Margin (dB)
55.713928	22	H	3.86	25.21	7.46	0.23	10.46	22.44	39.00	-16.56
55.713928	308	V	1.00	31.60	7.46	0.23	10.46	28.83	39.00	-10.17
687.51653	136	H	1.00	25.92	20.50	1.50	10.46	37.46	46.40	-8.94
687.51653	329	V	1.00	22.62	20.50	1.50	10.46	34.16	46.40	-12.24
356.37575	189	H	1.00	27.13	15.33	0.83	10.46	32.83	46.40	-13.57
356.37575	331	V	1.00	25.69	15.33	0.83	10.46	31.39	46.40	-15.01
562.51353	125	H	1.16	21.96	18.80	1.09	10.46	31.39	46.40	-15.01
562.51353	134	V	1.00	21.60	18.80	1.09	10.46	31.03	46.40	-15.37
97.96994	121	H	1.95	22.66	9.79	0.23	10.46	22.22	43.50	-21.28
97.96994	360	V	1.00	25.50	9.79	0.23	10.46	25.06	43.50	-18.44
499.98747	248	H	1.00	19.41	18.00	1.00	10.46	27.95	46.40	-18.45
499.98747	124	V	1.00	23.92	18.00	1.00	10.46	32.46	46.40	-13.94

Table 11. Radiated Emissions Limits, Test Results, FCC Limits

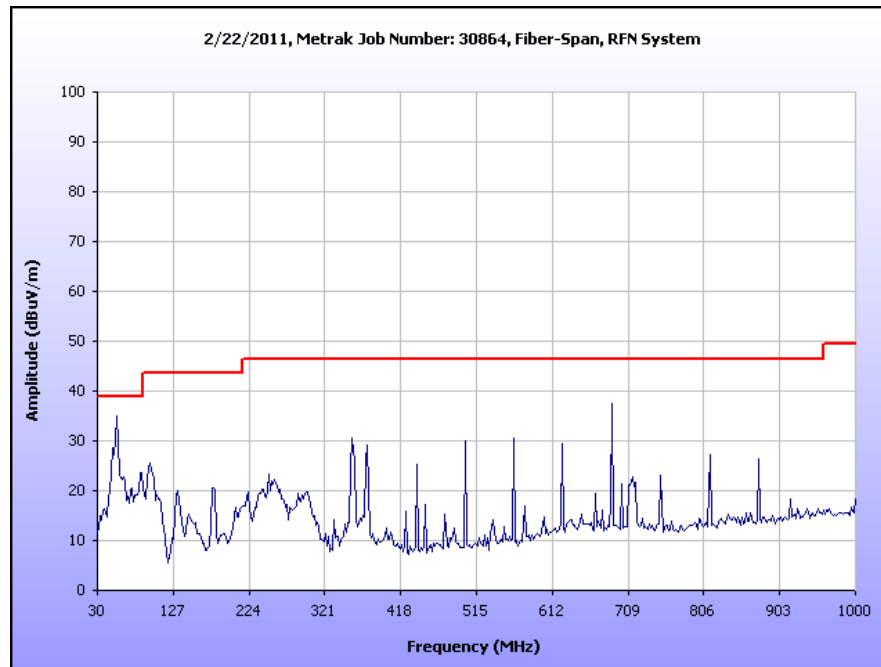

Plot 3. Radiated Emissions, Pre-Scan, FCC Limits

Radiated Emissions Limits Test Results, Class A

Frequency (MHz)	EUT Azimuth (Degrees)	Antenna Polarity (H/V)	Antenna HEIGHT (m)	Uncorrected Amplitude (dBuV)	Antenna Correction Factor (dB) (+)	Cable Loss (dB) (+)	Distance Correction Factor (dB) (-)	Corrected Amplitude (dBuV/m)	Limit (dBuV/m)	Margin (dB)
55.713928	22	H	3.86	25.21	7.46	0.23	10.46	22.44	40.00	-17.56
55.713928	308	V	1.00	31.60	7.46	0.23	10.46	28.83	40.00	-11.17
687.51653	136	H	1.00	25.92	20.50	1.50	10.46	37.46	47.00	-9.54
687.51653	329	V	1.00	22.62	20.50	1.50	10.46	34.16	47.00	-12.84
356.37575	189	H	1.00	27.13	15.33	0.83	10.46	32.83	47.00	-14.17
356.37575	331	V	1.00	25.69	15.33	0.83	10.46	31.39	47.00	-15.61
562.51353	125	H	1.16	21.96	18.80	1.09	10.46	31.39	47.00	-15.61
562.51353	134	V	1.00	21.60	18.80	1.09	10.46	31.03	47.00	-15.97
97.96994	121	H	1.95	22.66	9.79	0.23	10.46	22.22	40.00	-17.78
97.96994	360	V	1.00	25.50	9.79	0.23	10.46	25.06	40.00	-14.94
499.98747	248	H	1.00	19.41	18.00	1.00	10.46	27.95	47.00	-19.05
499.98747	124	V	1.00	23.92	18.00	1.00	10.46	32.46	47.00	-14.54

Table 12. Radiated Emissions Limits, Test Results, ICES-003 Limits

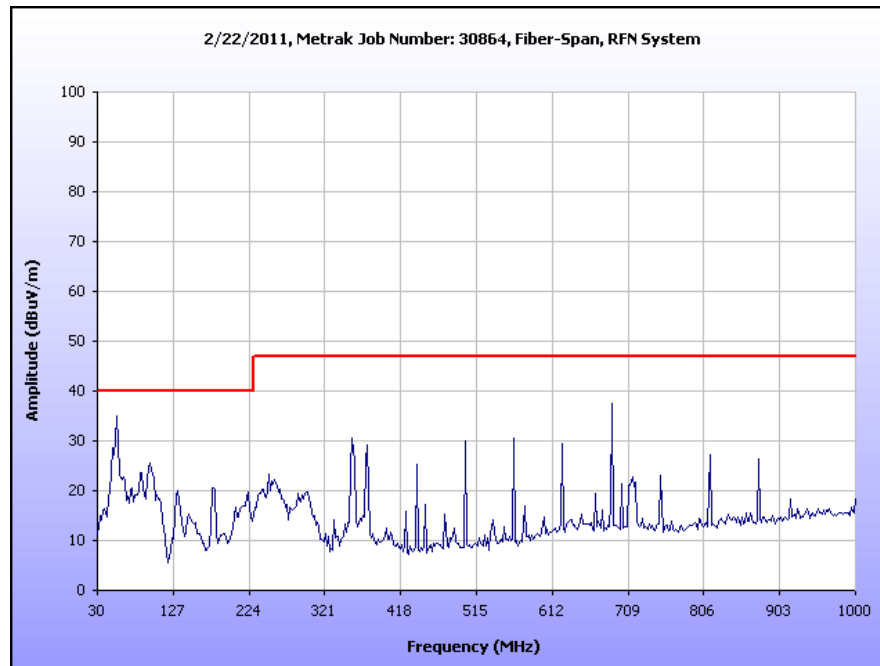

Plot 4. Radiated Emissions, Pre-Scan, ICES-003 Limits

Radiated Emission Limits Test Setup

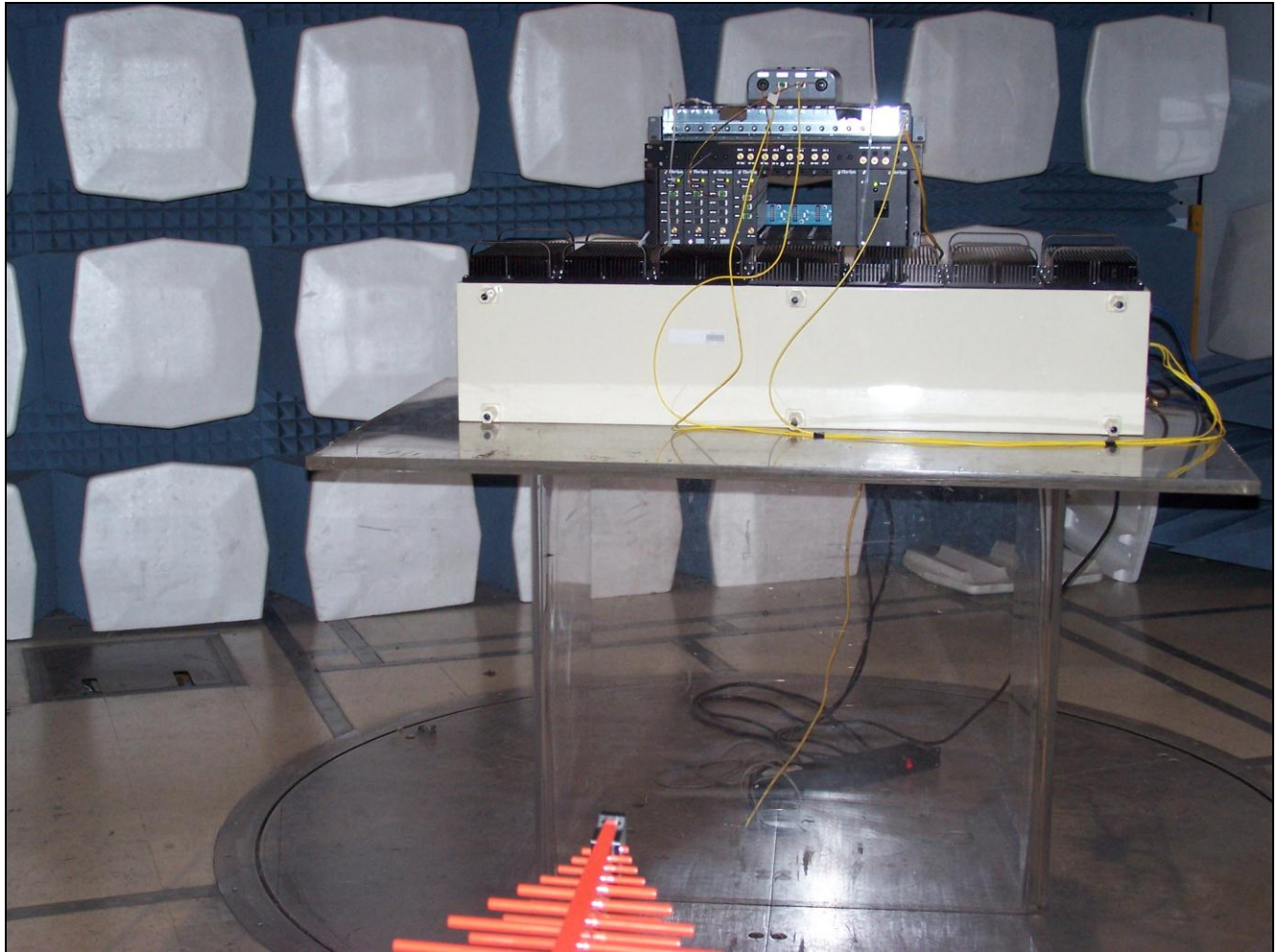

Photograph 2. Radiated Emission Limits, Test Setup

IV. Electromagnetic Compatibility Criteria for Intentional Radiators

Electromagnetic Compatibility Criteria for Intentional Radiators

§ 2.1046 RF Power Output

Test Requirements: § 2.1046 Measurements required: RF power output:

§ 2.1046 (a) For transmitters other than single sideband, independent sideband and controlled carrier radiotelephone, power output shall be measured at the RF output terminals when the transmitter is adjusted in accordance with the tune-up procedure to give the values of current and voltage on the circuit elements specified in § 2.1033(c)(8). The electrical characteristics of the radio frequency load attached to the output terminals when this test is made shall be stated.

§ 2.1046 (b) For single sideband, independent sideband, and single channel, controlled carrier radiotelephone transmitters, the procedure specified in paragraph (a) of this section shall be employed and, in addition, the transmitter shall be modulated during the test as specified and as applicable in § 2.1046 (b) (1-5). In all tests, the input level of the modulating signal shall be such as to develop rated peak envelope power or carrier power, as appropriate, for the transmitter.

§ 2.1046 (c) For measurements conducted pursuant to paragraphs (a) and (b) of this section, all calculations and methods used by the applicant for determining carrier power or peak envelope power, as appropriate, on the basis of measured power in the radio frequency load attached to the transmitter output terminals shall be shown. Under the test conditions specified, no components of the emission spectrum shall exceed the limits specified in the applicable rule parts as necessary for meeting occupied bandwidth or emission limitations.

§ 24.232 Power and antenna height limits.

§ 24.232 (c): Mobile/portable stations are limited to 2 watts e.i.r.p. peak power and the equipment must employ means to limit the power to the minimum necessary for successful communications.

Test Procedures: As required by 47 CFR 2.1046, RF power output measurements were made at the RF output terminals using an attenuator and spectrum analyzer. The spectrum analyzer was set to its default settings – RBW, VBW, Sweep Time, etc. – except that the detector was set to an average detector. The “Channel Power” measurement feature of the spectrum analyzer was used to determine the input and output power across the Occupied Bandwidth. Measurements were made with both a Peak and Average detector.

Test Results: The EUT complies with the requirements of this section. The EUT conducted power does not exceed limit at the carrier frequency. Power was measured on port 1 and then the combined power on all 3 ports was calculated. The plots below show the power on port 1.

Test Engineer(s): Dusmantha Tennakoon

Test Date(s): 02/22/11

Band	Link	Frequency (MHz)	Power In (dBm)	Avg Power Out-Port 1 (dBm)	Peak Power Out-Port 1 (dBm)	Summed Avg Power- Port 1+2+3 (dBm)	Gain (dB)
EVDO	DL	1930.670	-10	24.70	28.53	28.22	34.7
		1962.000	-10	25.45	29.69	28.97	35.5
		1994.330	-10	22.29	27.39	25.81	32.3
	UL	1850.670	-35	-17.26	-11.52	-13.74	17.7
		1885.000	-35	-17.50	-12.07	-13.98	17.5
		1914.330	-35	-21.30	-15.98	-17.78	13.7
LTE	DL	1930.700	-13	23.19	28.21	26.71	36.2
		1962.000	-13	25.17	30.20	28.69	38.2
		1994.300	-13	22.42	27.60	25.94	35.4
	UL	1850.700	-32	-13.47	-7.93	-9.95	18.5
		1885.000	-32	-13.98	-8.36	-10.46	18.0
		1914.300	-32	-17.95	-12.26	-14.43	14.1
GSM	DL	1930.125	-11.22	23.58	23.77	27.10	34.8
		1962.000	-11.22	23.90	24.69	27.42	35.1
		1994.875	-11.22	23.22	23.16	26.74	34.4
	UL	1850.125	-30	-12.68	-12.60	-9.16	17.3
		1885.000	-30	-12.85	-12.86	-9.33	17.2
		1914.875	-30	-17.05	-16.97	-13.53	13.0

Table 13. RF Output Power, Test Results

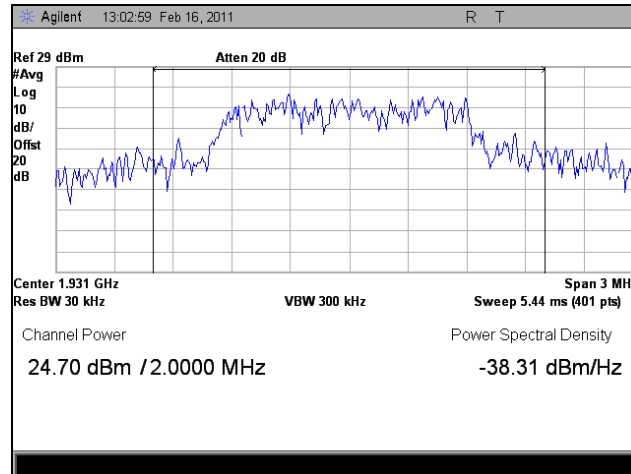

Plot 5. 1930.67 MHz, RF Power Output, Downlink, EVDO, Average

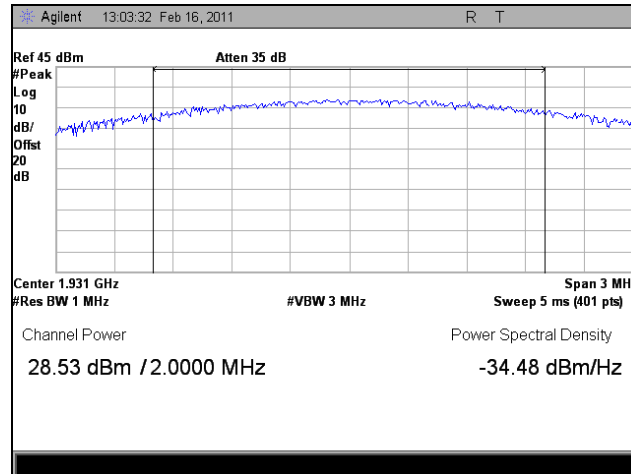

Plot 6. 1930.67 MHz, RF Power Output, Downlink, EVDO, Peak

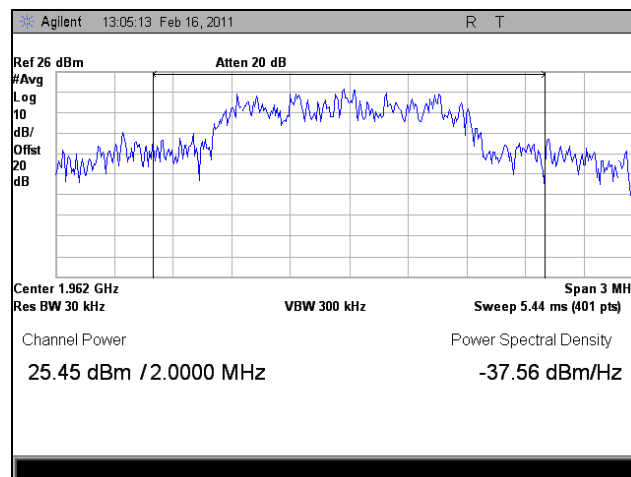

Plot 7. 1962 MHz, RF Power Output, Downlink, EVDO, Average

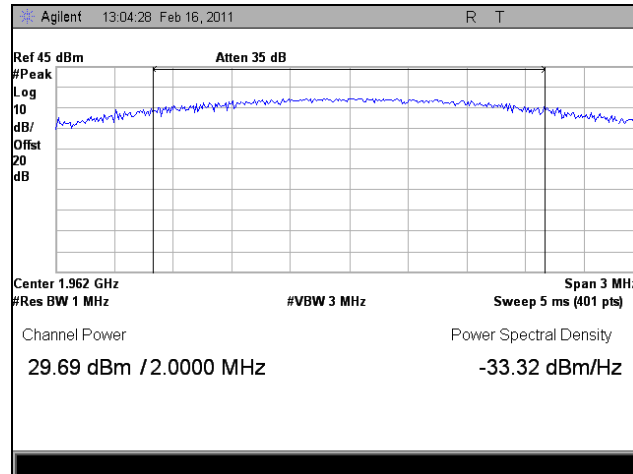

Plot 8. 1962 MHz, RF Power Output, Downlink, EVDO, Peak

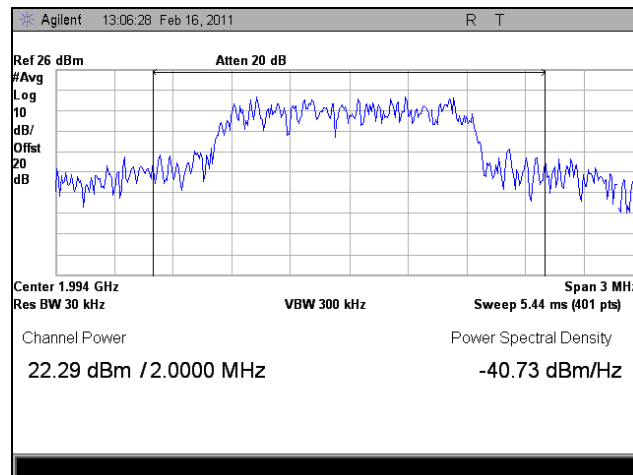

Plot 9. 1994.33 MHz, RF Power Output, Downlink, EVDO, Average

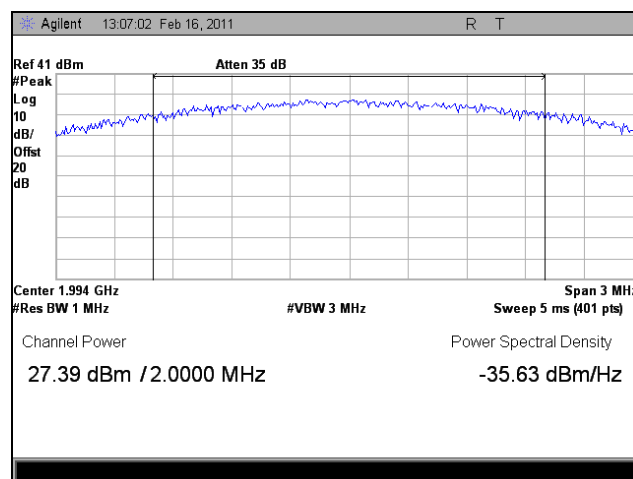

Plot 10. 1994.33 MHz, RF Power Output, Downlink, EVDO, Peak

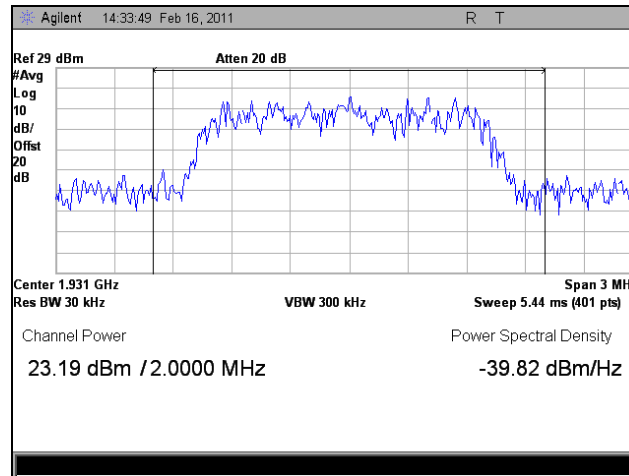

Plot 11. 1930.7 MHz, RF Power Output, Downlink, LTE, Average

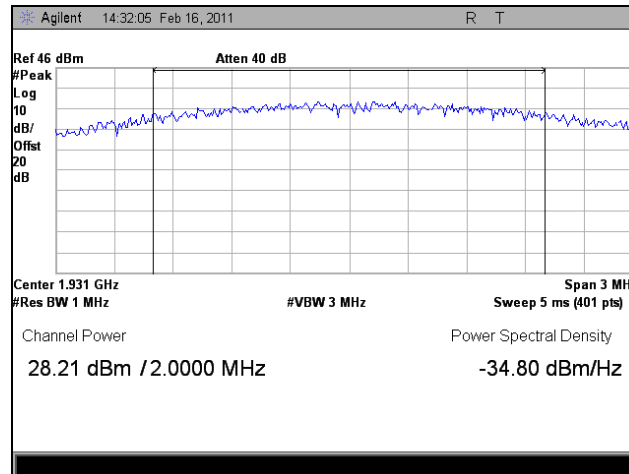

Plot 12. 1930.7 MHz, RF Power Output, Downlink, LTE, Peak

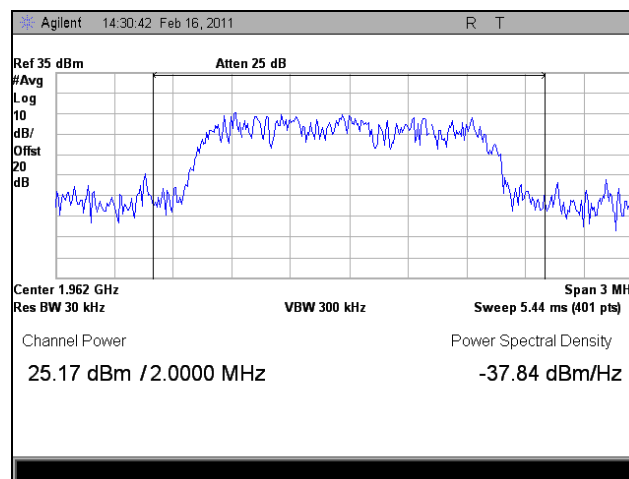

Plot 13. 1962 MHz, RF Power Output, Downlink, LTE, Average

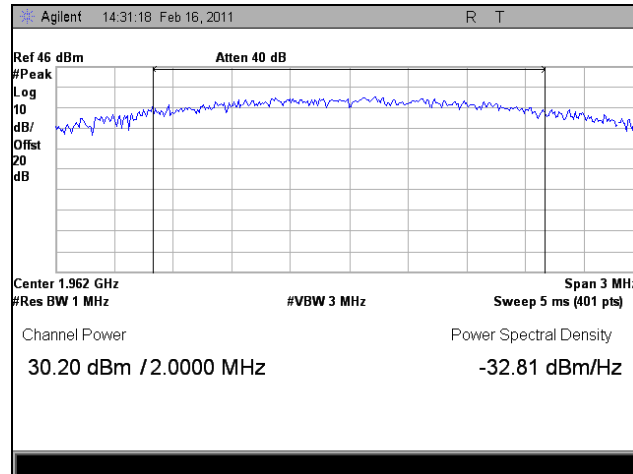

Plot 14. 1962 MHz, RF Power Output, Downlink, LTE, Peak

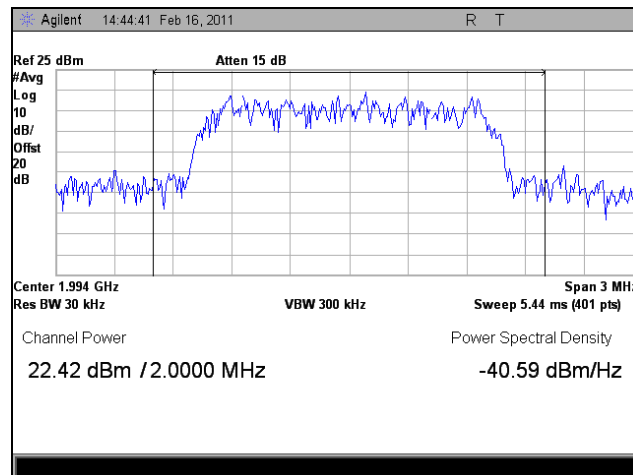

Plot 15. 1994.3 MHz, RF Power Output, Downlink, LTE, Average

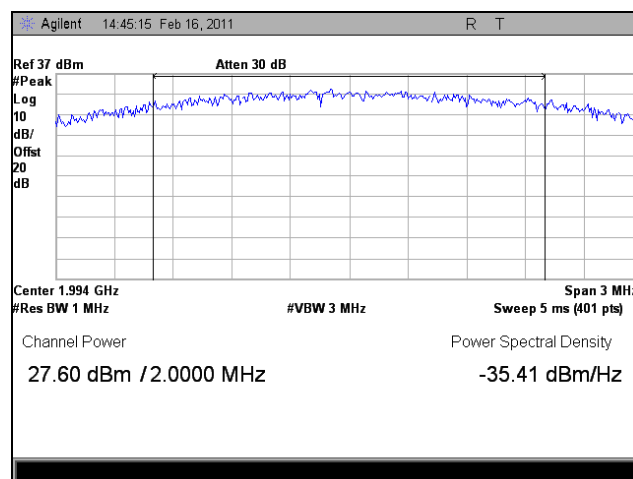

Plot 16. 1994.3 MHz, RF Power Output, Downlink, LTE, Peak

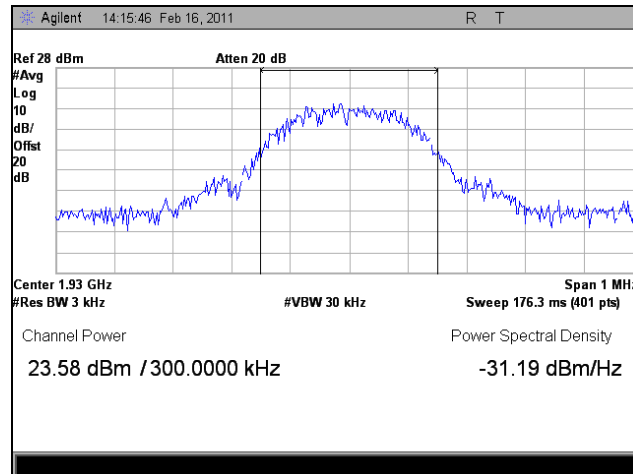

Plot 17. 1930.125 MHz, RF Power Output, Downlink, GSM, Average

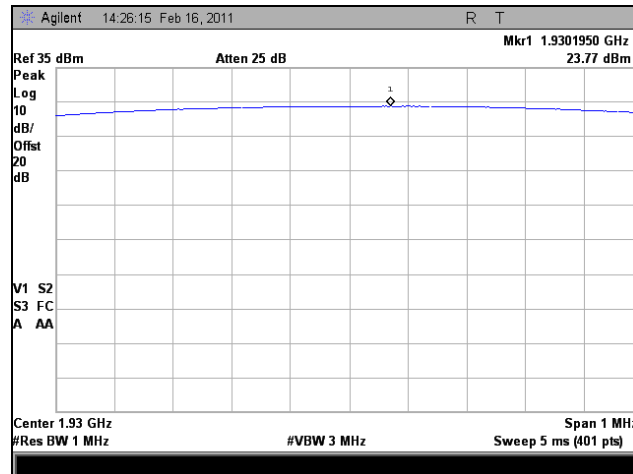

Plot 18. 1930.125 MHz, RF Power Output, Downlink, GSM, Peak

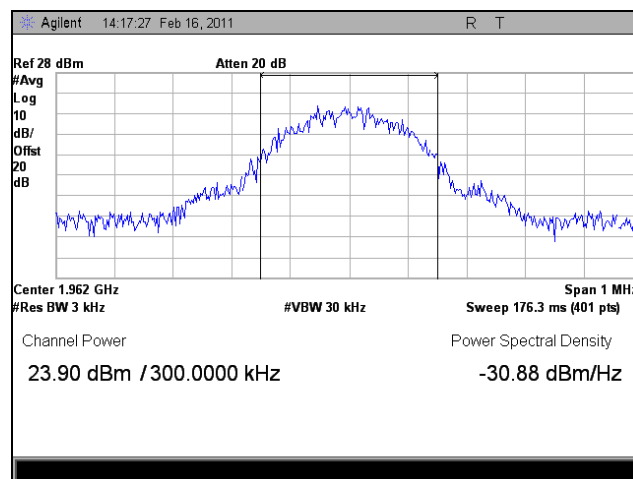

Plot 19. 1962 MHz, RF Power Output, Downlink, GSM, Average

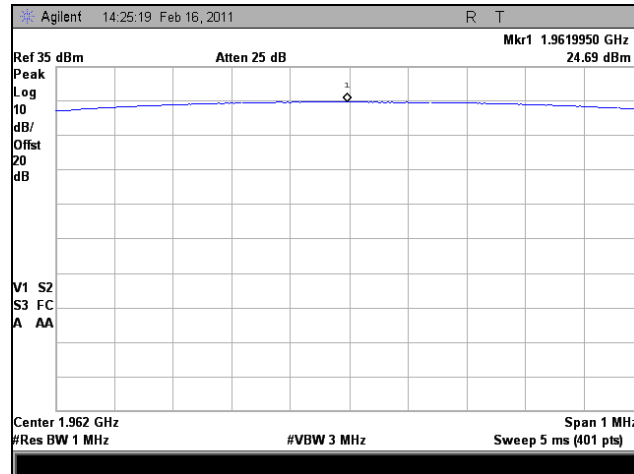

Plot 20. 1962 MHz, RF Power Output, Downlink, GSM, Peak

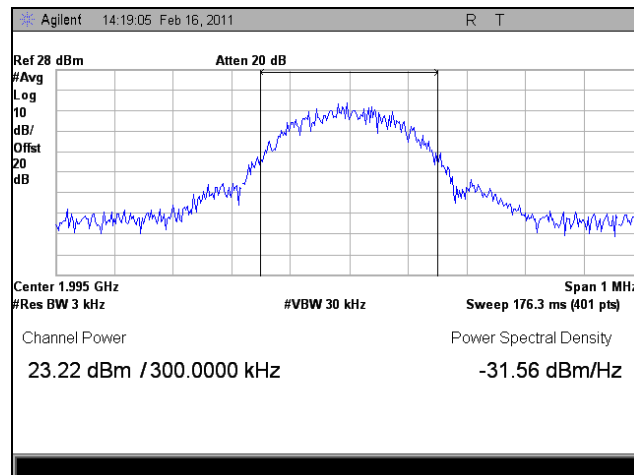

Plot 21. 1994.875 MHz, RF Power Output, Downlink, GSM, Average

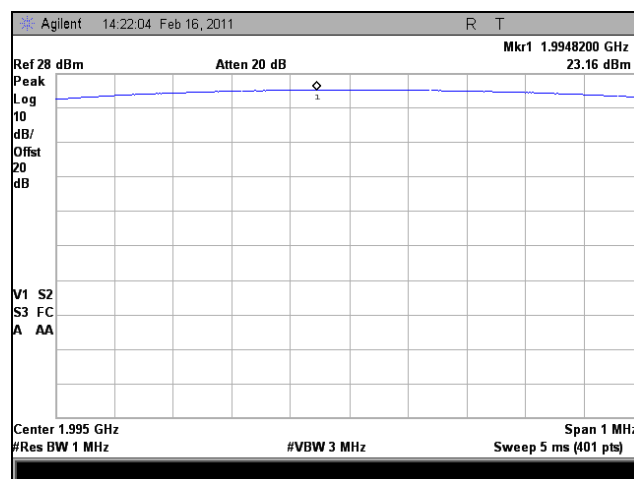

Plot 22. 1994.875 MHz, RF Power Output, Downlink, GSM, Peak

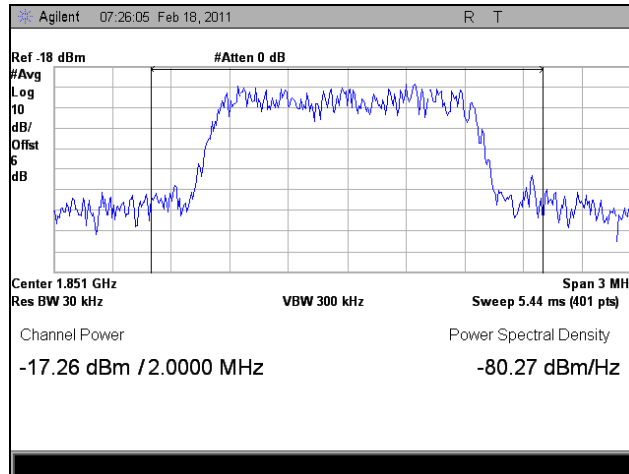

Plot 23. 1850.67 MHz, RF Power Output, Uplink, EVDO, Average

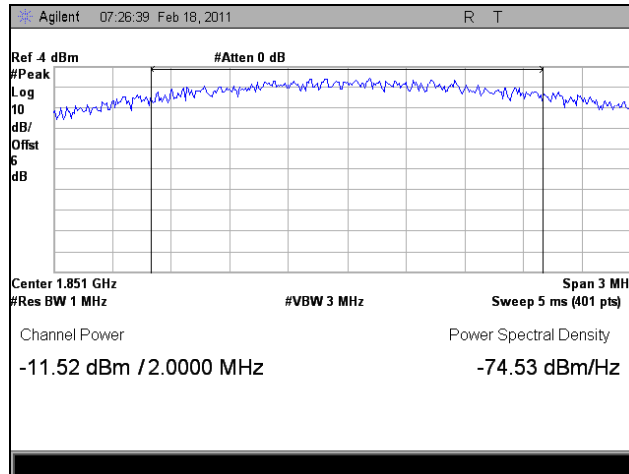

Plot 24. 1850.67 MHz, RF Power Output, Uplink, EVDO, Peak

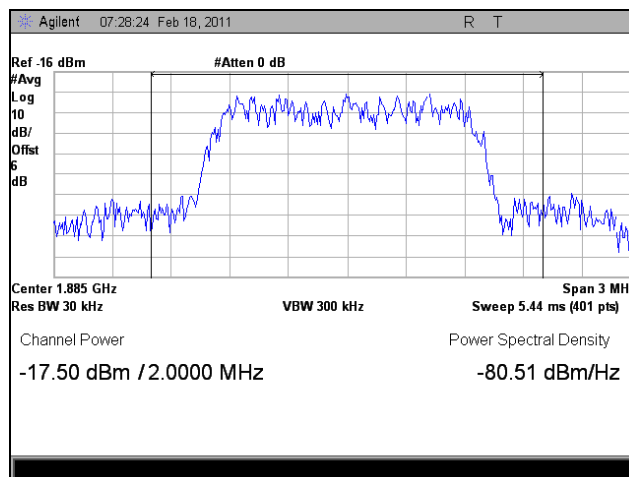

Plot 25. 1885 MHz, RF Power Output, Uplink, EVDO, Average

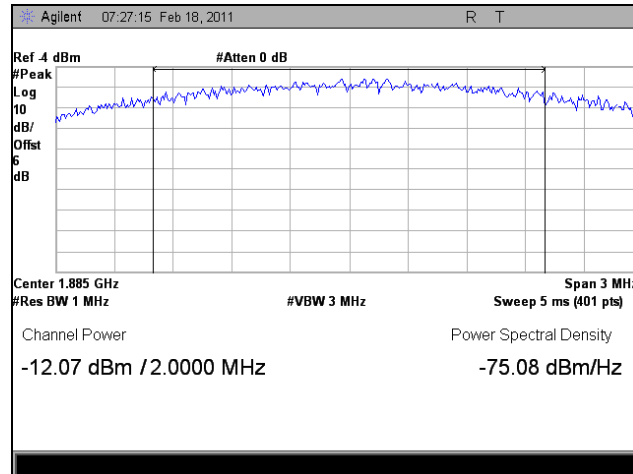

Plot 26. 1885 MHz, RF Power Output, Uplink, EVDO, Peak

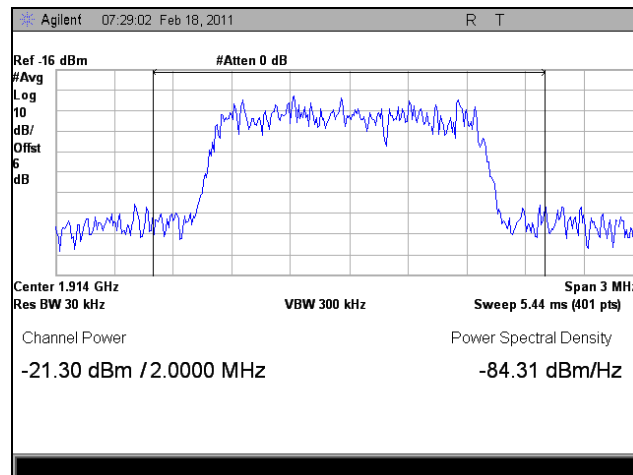

Plot 27. 1944.33 MHz, RF Power Output, Uplink, EVDO, Average

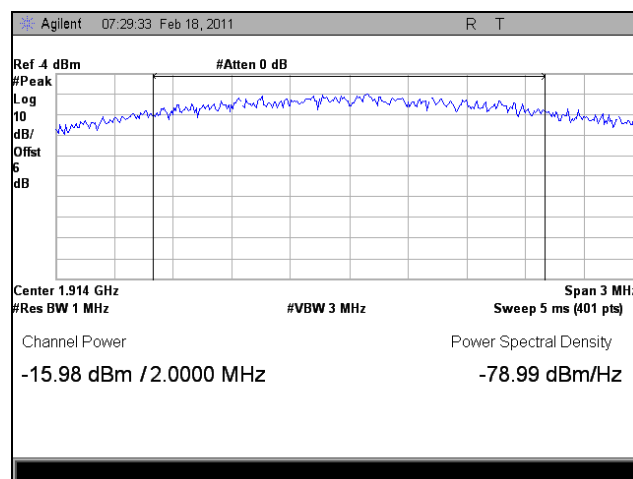

Plot 28. 1944.33 MHz, RF Power Output, Uplink, EVDO, Peak

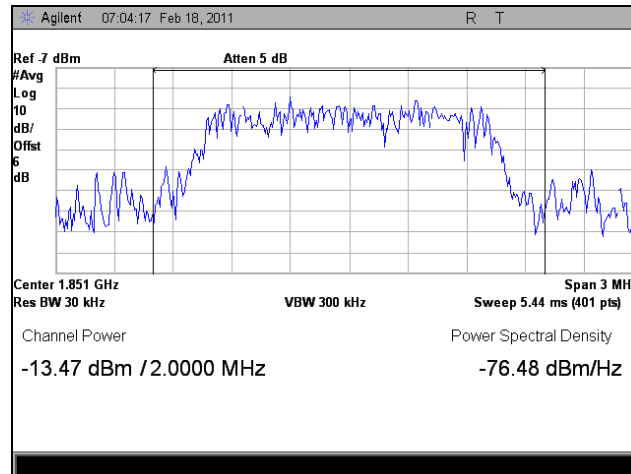

Plot 29. 1850.7 MHz, RF Power Output, Uplink, LTE, Average

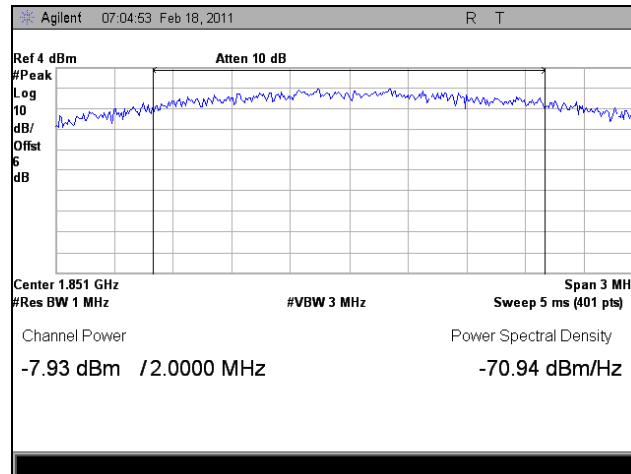

Plot 30. 1850.7 MHz, RF Power Output, Uplink, LTE, Peak

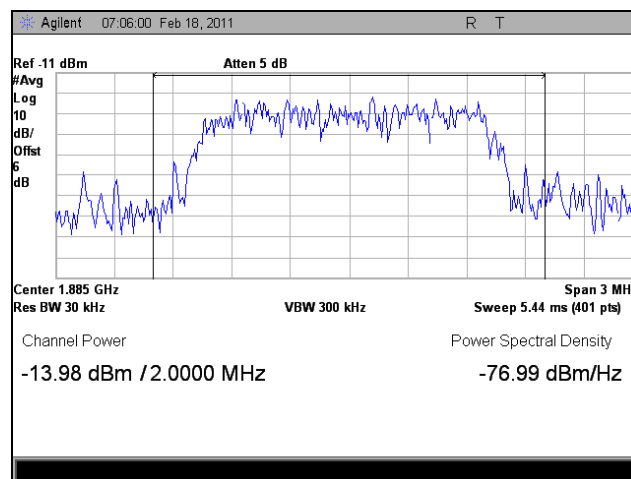

Plot 31. 1885 MHz, RF Power Output, Uplink, LTE, Average

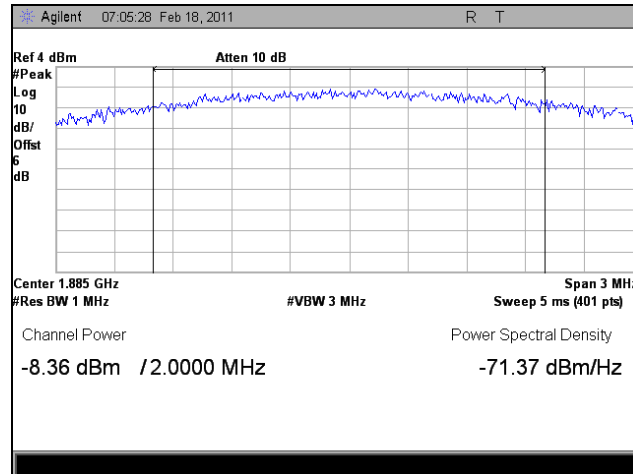

Plot 32. 1885 MHz, RF Power Output, Uplink, LTE, Peak

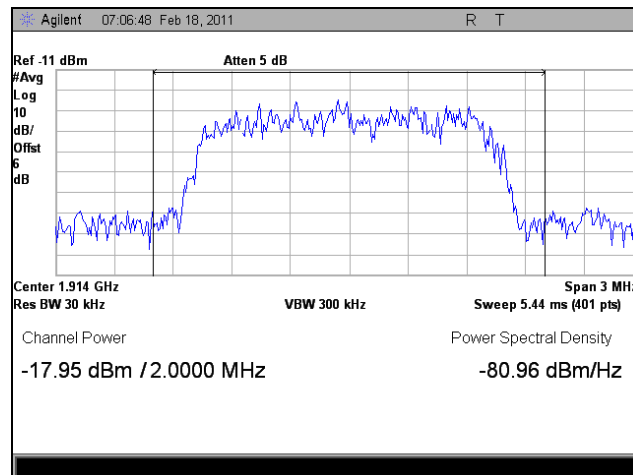

Plot 33. 1914.3 MHz, RF Power Output, Uplink, LTE, Average

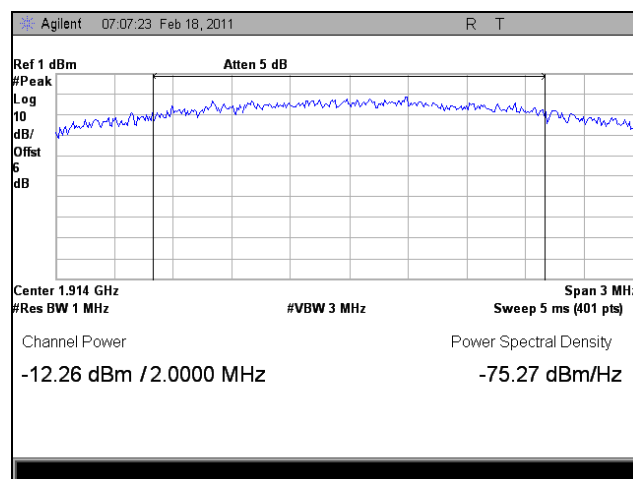

Plot 34. 1914.3 MHz, RF Power Output, Uplink, LTE, Peak

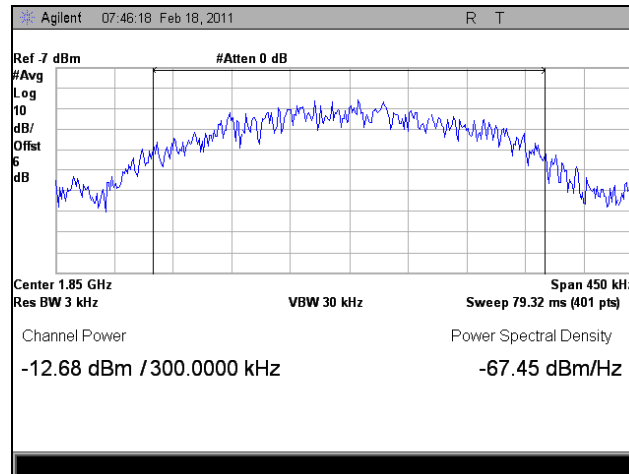

Plot 35. 1950.125 MHz, RF Power Output, Uplink, GSM, Average

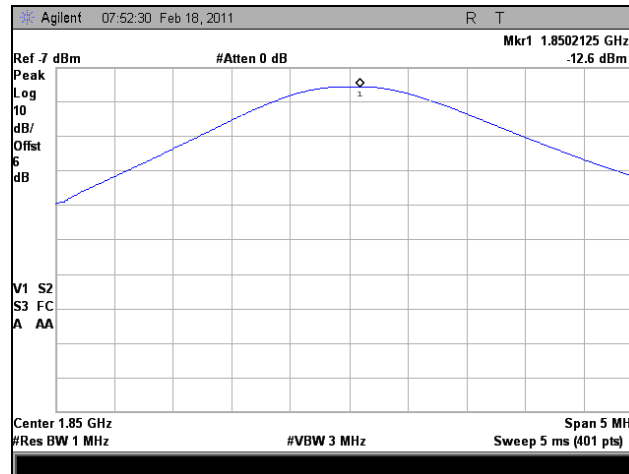

Plot 36. 1950.125 MHz, RF Power Output, Uplink, GSM, Peak

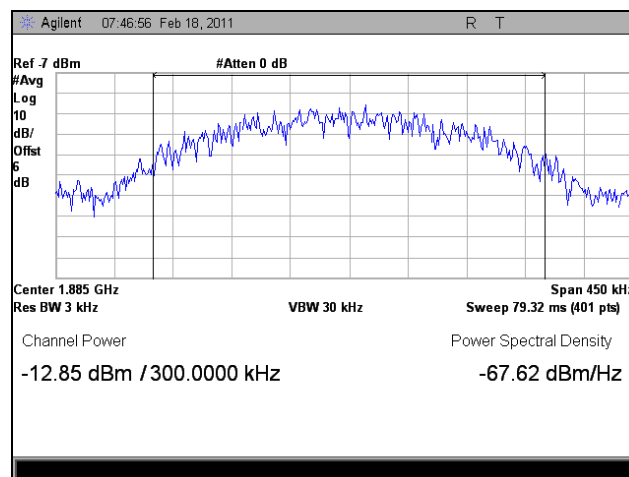

Plot 37. 1885 MHz, RF Power Output, Uplink, GSM, Average

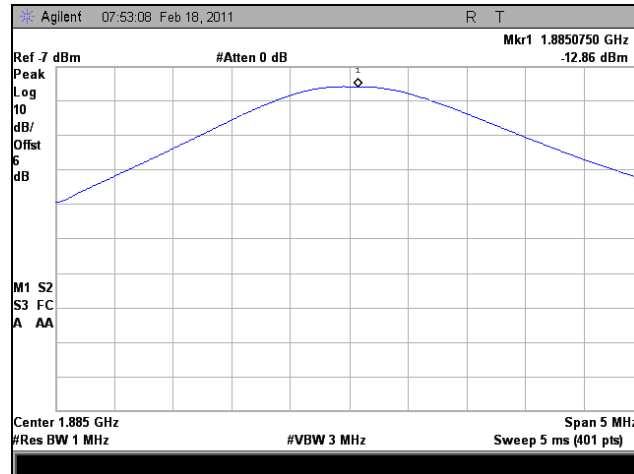

Plot 38. 1885 MHz, RF Power Output, Uplink, GSM, Peak

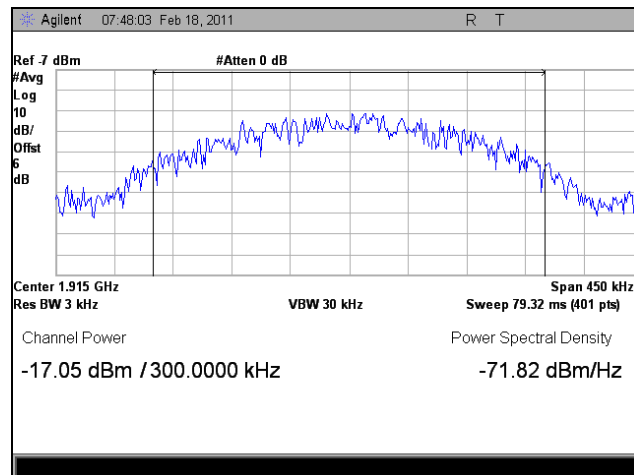

Plot 39. 1914.875 MHz, RF Power Output, Uplink, GSM, Average

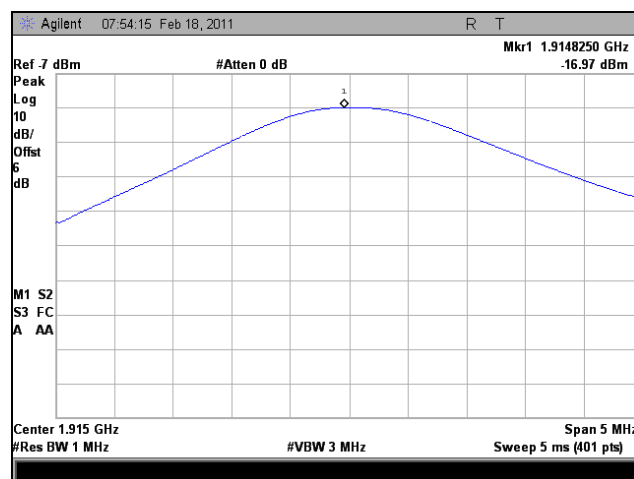

Plot 40. 1914.875 MHz, RF Power Output, Uplink, GSM, Peak



Photograph 3. RF Power, Test Setup

§ 2.1049 Occupied Bandwidth

- Test Requirement(s):** **§ 2.1049 Measurements required: Occupied bandwidth:** The occupied bandwidth, that is the frequency bandwidth such that, below its lower and above its upper frequency limits, the mean powers radiated are each equal to 0.5 percent of the total mean power radiated by a given emission shall be measured under the specified conditions of § 2.1049 (a) through (i) as applicable.
- Test Procedures:** As required by 47 CFR 2.1049, *occupied bandwidth measurements* were made with a Spectrum Analyzer connected to the RF port.
- Test Results:** The EUT complies with the requirements of this section.
- Test Engineer(s):** Dusmantha Tennakoon
- Test Date(s):** 02/22/11

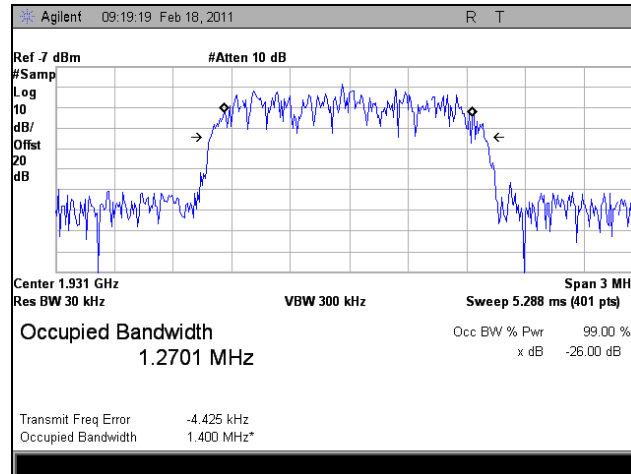

Plot 41. 1930.67 MHz, Occupied Bandwidth, Downlink, EVDO, In

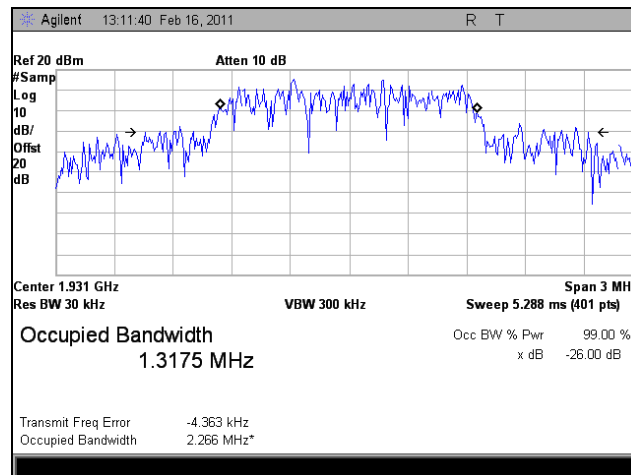

Plot 42. 1930.67 MHz, Occupied Bandwidth, Downlink, EVDO, Out

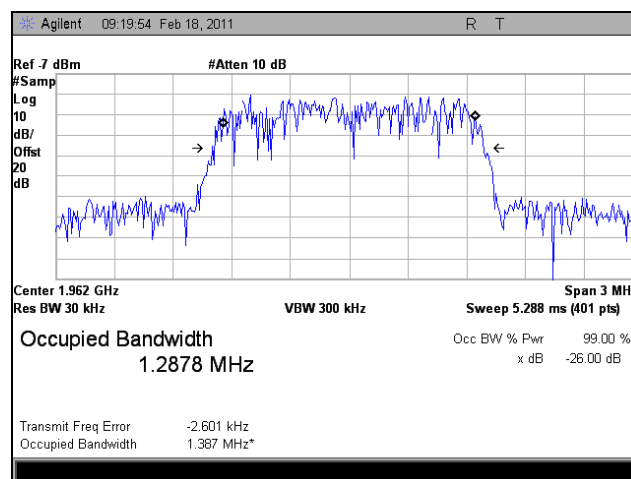

Plot 43. 1962 MHz, Occupied Bandwidth, Downlink, EVDO, In

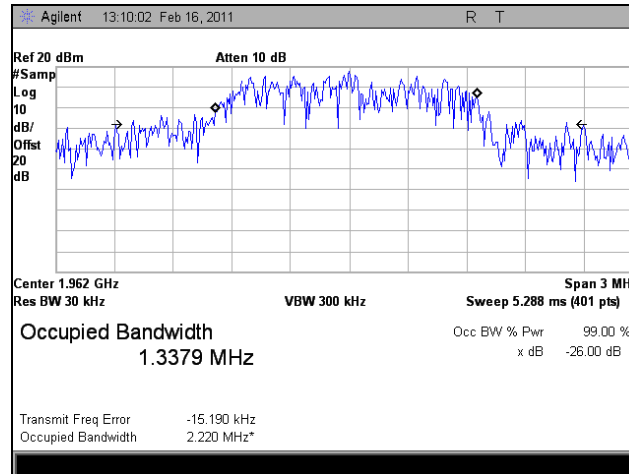

Plot 44. 1962 MHz, Occupied Bandwidth, Downlink, EVDO, Out

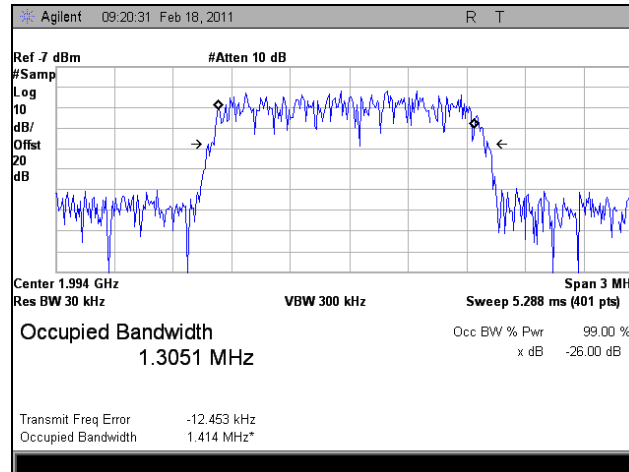

Plot 45. 1994.33 MHz, Occupied Bandwidth, Downlink, EVDO, In

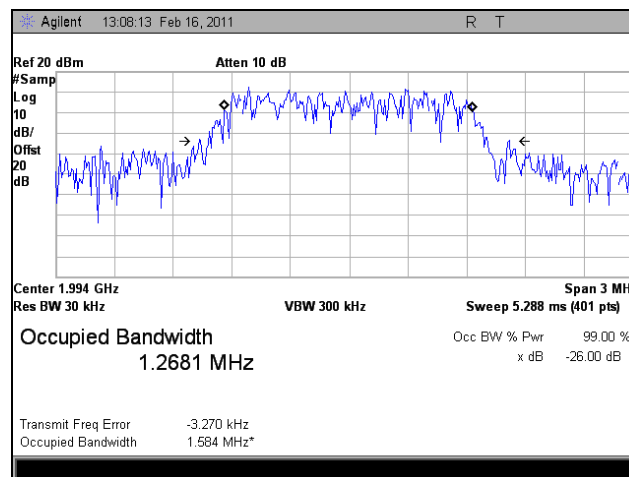

Plot 46. 1994.33 MHz, Occupied Bandwidth, Downlink, EVDO, Out

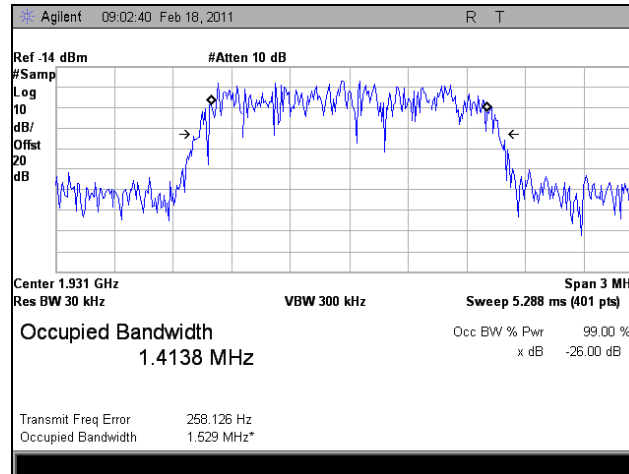

Plot 47. 1930.7 MHz, Occupied Bandwidth, Downlink, LTE, In

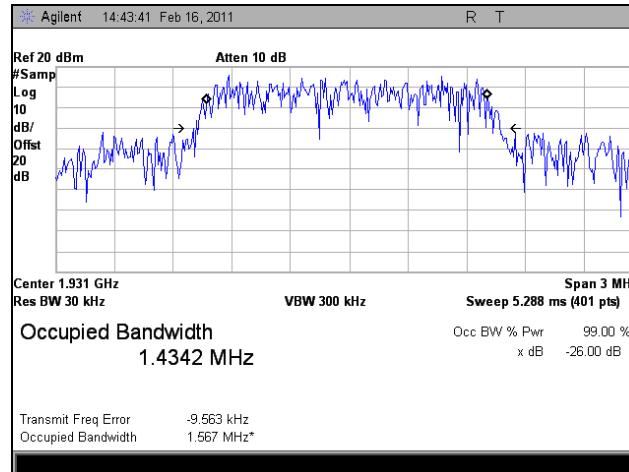

Plot 48. 1930.7 MHz, Occupied Bandwidth, Downlink, LTE, Out

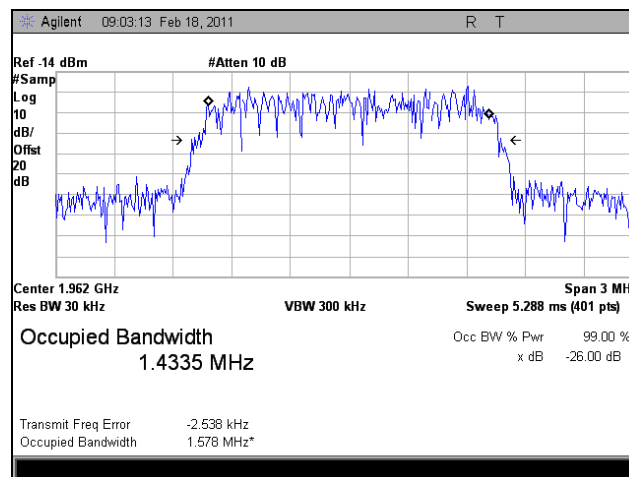

Plot 49. 1962 MHz, Occupied Bandwidth, Downlink, LTE, In

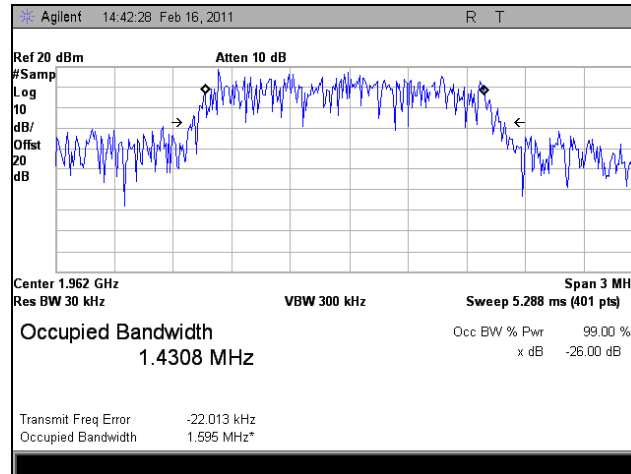

Plot 50. 1962 MHz, Occupied Bandwidth, Downlink, LTE, Out

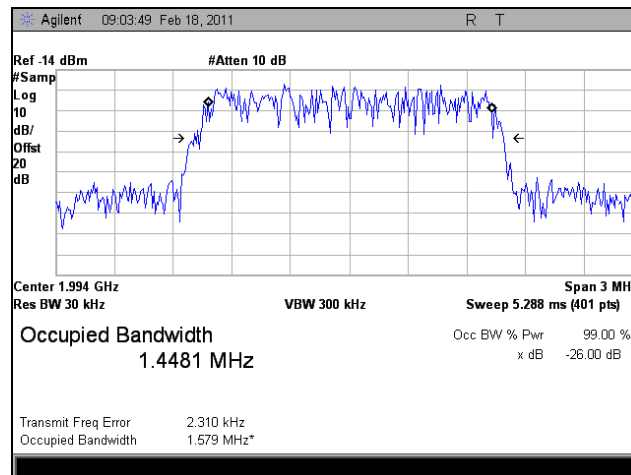

Plot 51. 1994.3 MHz, Occupied Bandwidth, Downlink, LTE, In

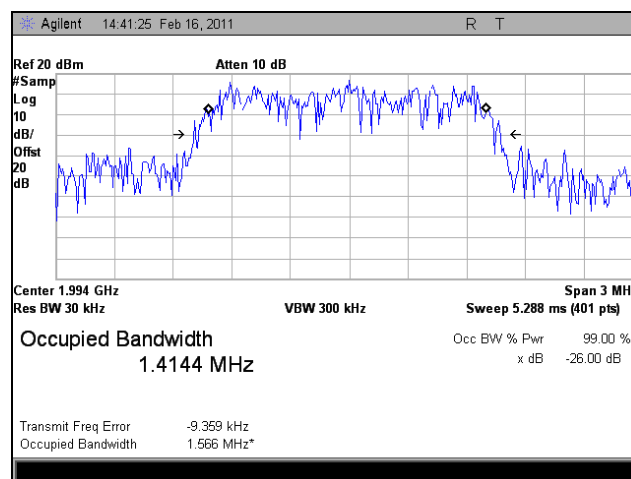

Plot 52. 1994.3 MHz, Occupied Bandwidth, Downlink, LTE, Out

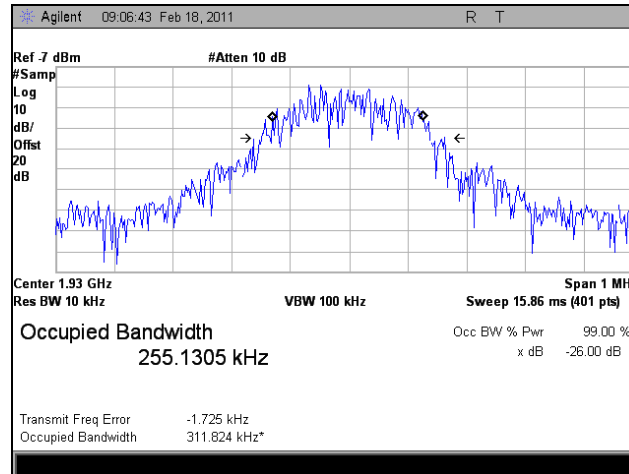

Plot 53. 1930.125 MHz, Occupied Bandwidth, Downlink, GSM, In

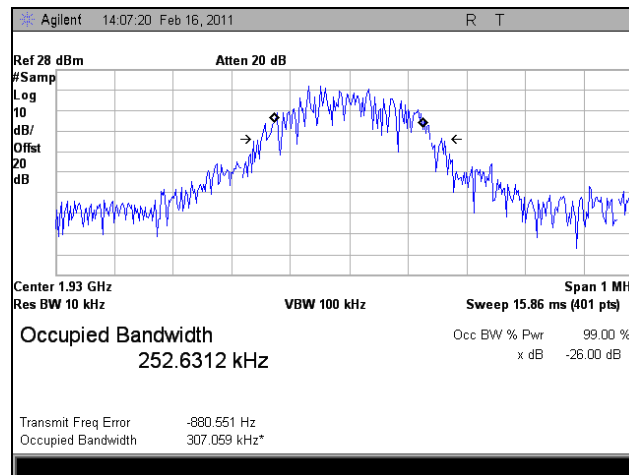

Plot 54. 1930.125 MHz, Occupied Bandwidth, Downlink, GSM, Out

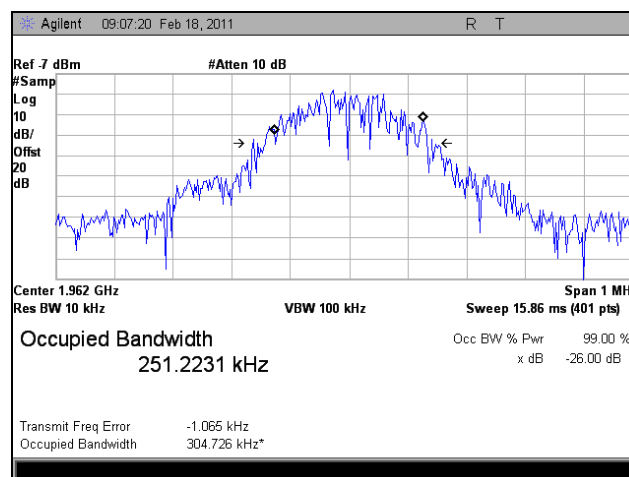

Plot 55. 1962 MHz, Occupied Bandwidth, Downlink, GSM, In

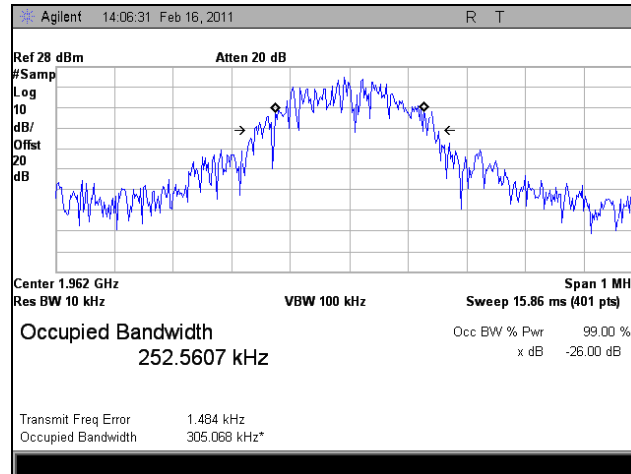

Plot 56. 1962 MHz, Occupied Bandwidth, Downlink, GSM, Out

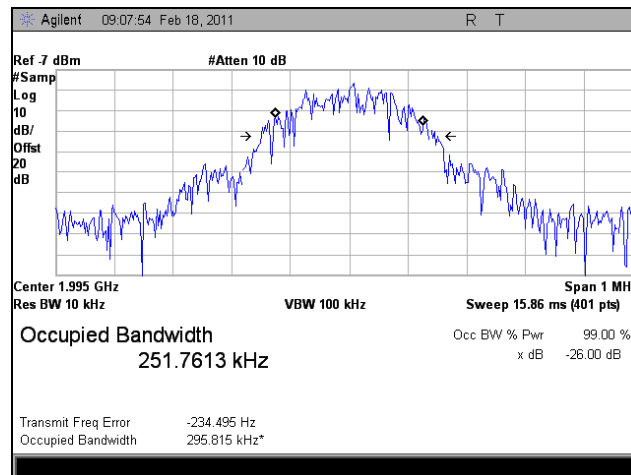

Plot 57. 1994.875 MHz, Occupied Bandwidth, Downlink, GSM, In

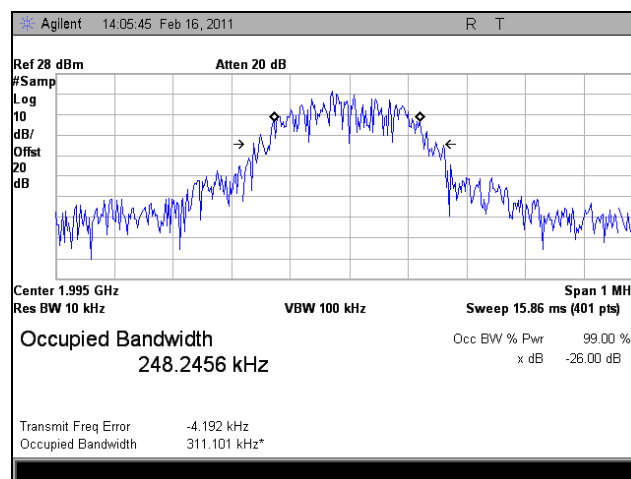

Plot 58. 1994.875 MHz, Occupied Bandwidth, Downlink, GSM, Out

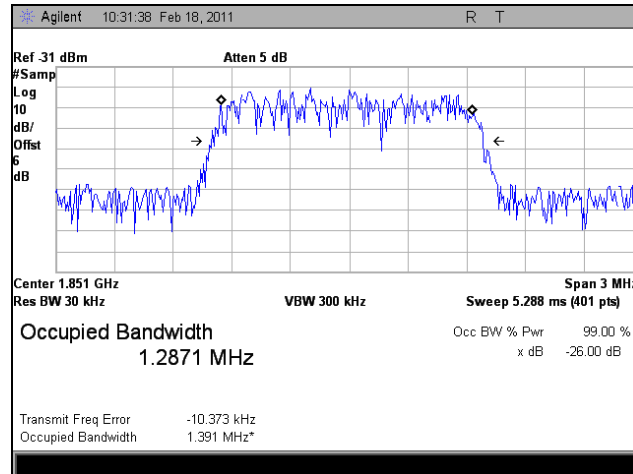

Plot 59. 1850.67 MHz, Occupied Bandwidth, Uplink, EVDO, In

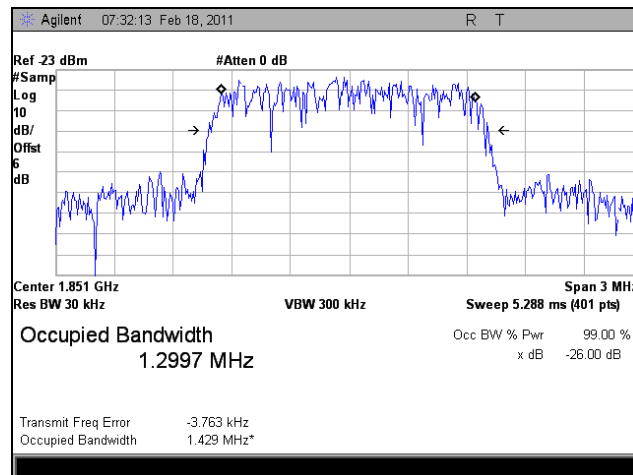

Plot 60. 1850.67 MHz, Occupied Bandwidth, Uplink, EVDO, Out

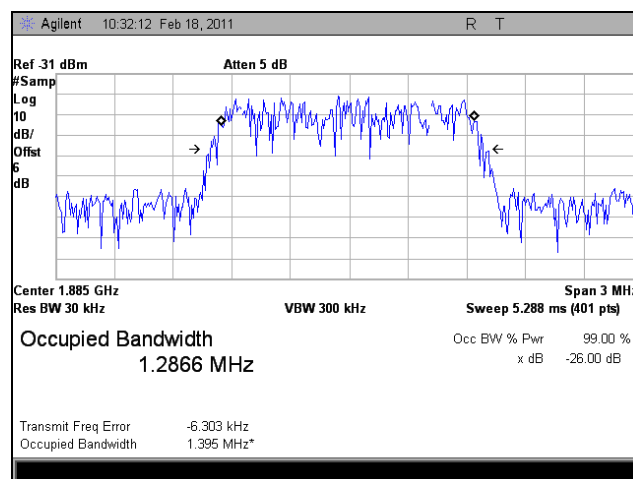

Plot 61. 1885 MHz, Occupied Bandwidth, Uplink, EVDO, In

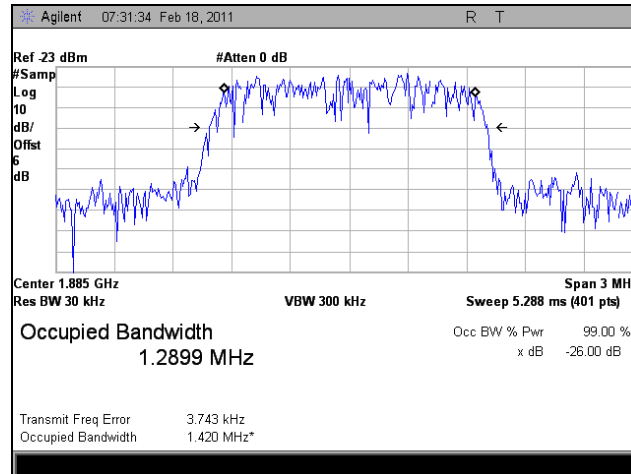

Plot 62. 1885 MHz, Occupied Bandwidth, Uplink, EVDO, Out

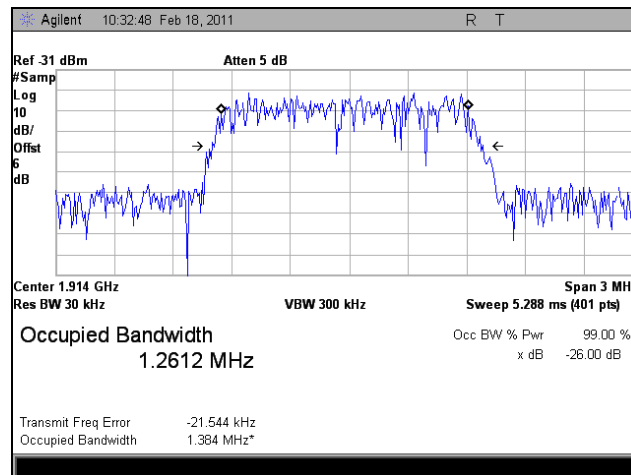

Plot 63. 1914.33 MHz, Occupied Bandwidth, Uplink, EVDO, In

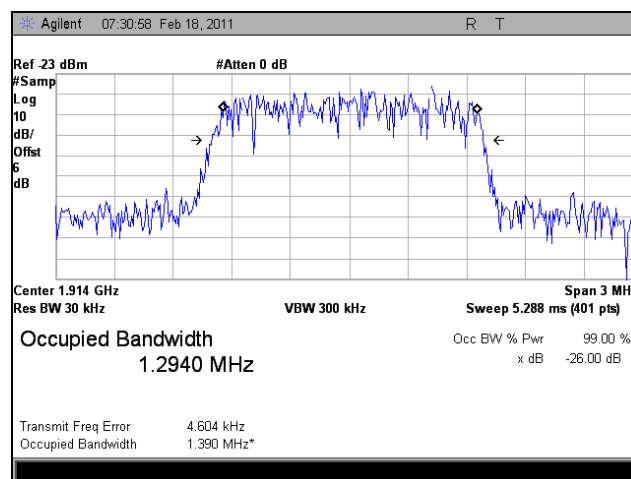

Plot 64. 1914.33 MHz, Occupied Bandwidth, Uplink, EVDO, Out

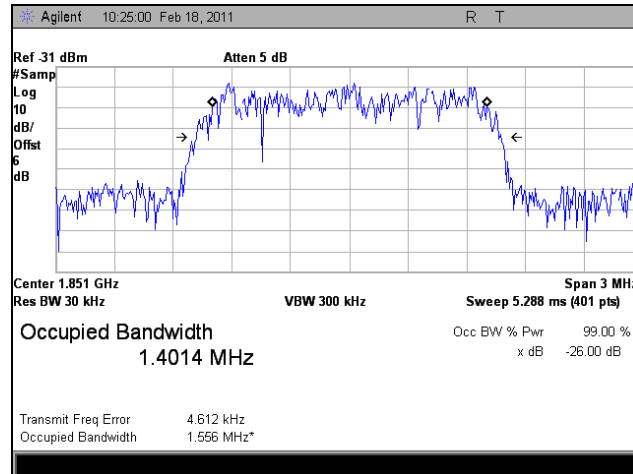

Plot 65. 1850.7 MHz, Occupied Bandwidth, Uplink, LTE, In

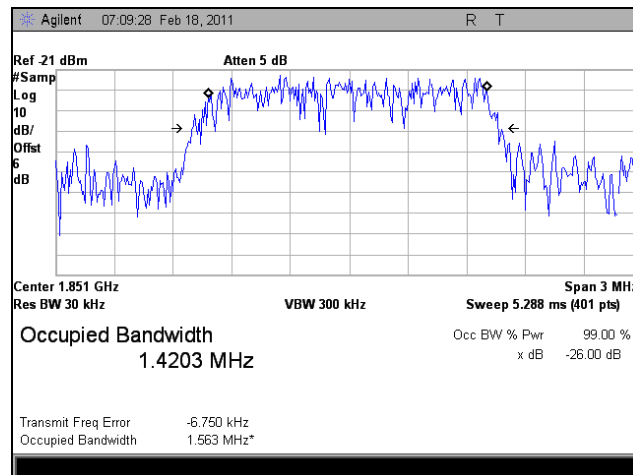

Plot 66. 1850.7 MHz, Occupied Bandwidth, Uplink, LTE, Out

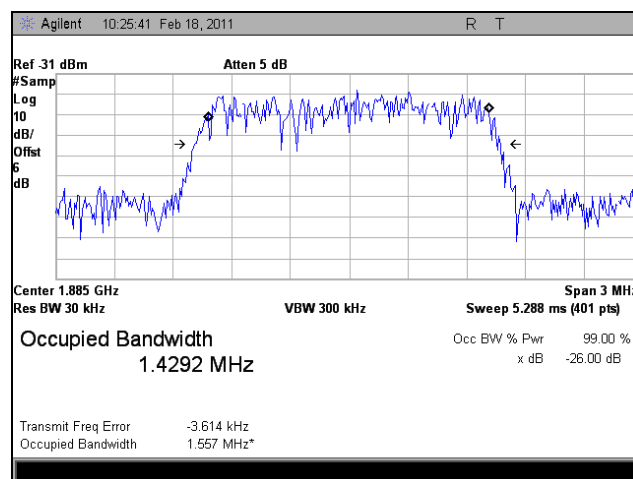

Plot 67. 1885 MHz, Occupied Bandwidth, Uplink, LTE, In

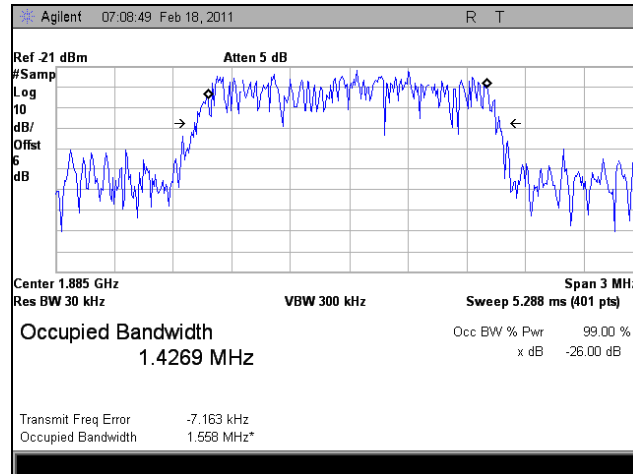

Plot 68. 1885 MHz, Occupied Bandwidth, Uplink, LTE, Out

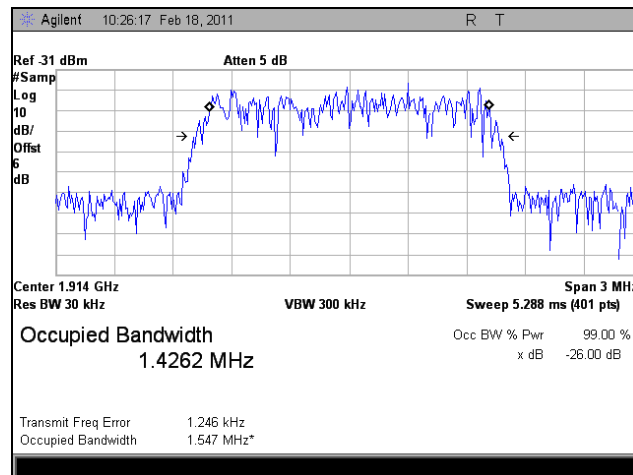

Plot 69. 1914.3 MHz, Occupied Bandwidth, Uplink, LTE, In

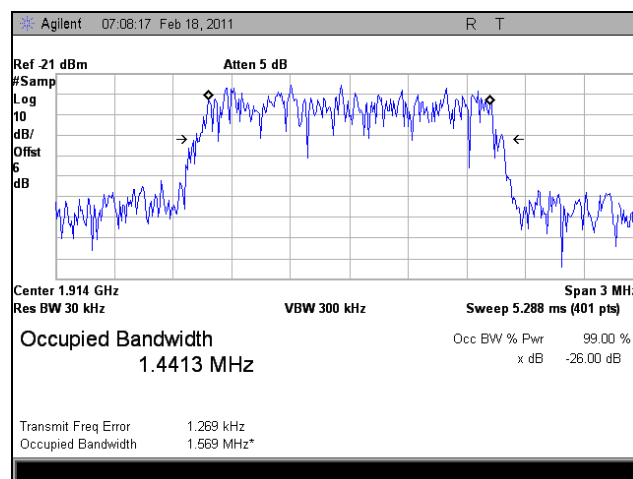

Plot 70. 1914.3 MHz, Occupied Bandwidth, Uplink, LTE, Out

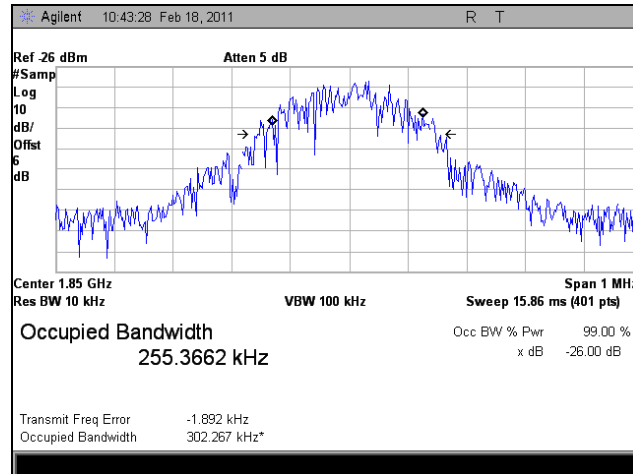

Plot 71. 1850.125 MHz, Occupied Bandwidth, Uplink, GSM, In

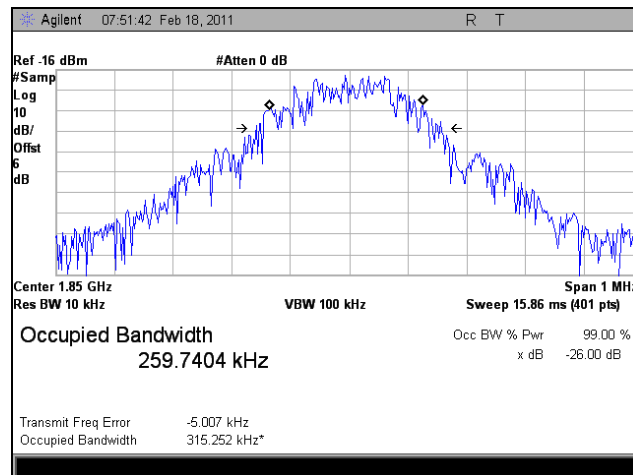

Plot 72. 1850.125 MHz, Occupied Bandwidth, Uplink, GSM, Out

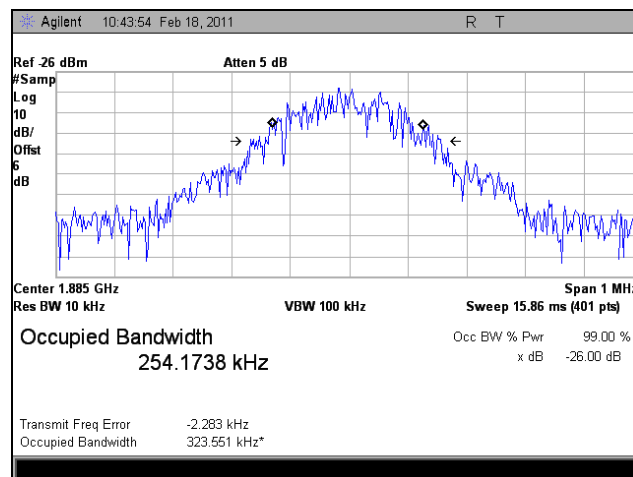

Plot 73. 1885 MHz, Occupied Bandwidth, Uplink, GSM, In

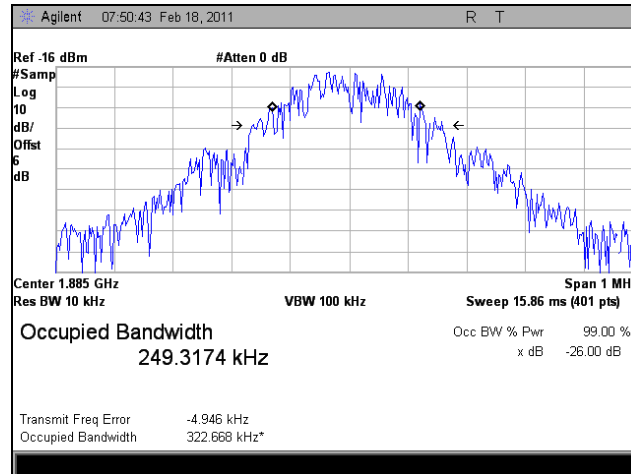

Plot 74. 1885 MHz, Occupied Bandwidth, Uplink, GSM, Out

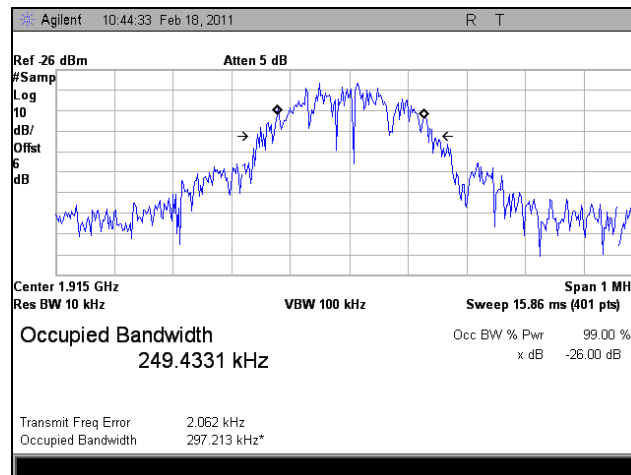

Plot 75. 1914.875 MHz, Occupied Bandwidth, Uplink, GSM, In

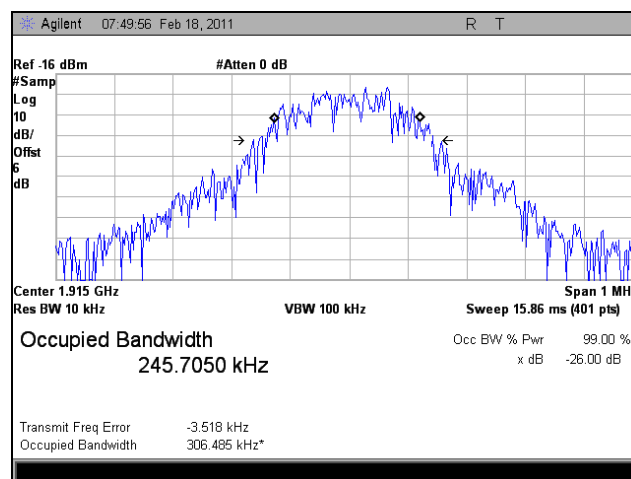

Plot 76. 1914.875 MHz, Occupied Bandwidth, Uplink, GSM, Out



Photograph 4. Occupied Bandwidth, Test Setup

Electromagnetic Compatibility Criteria for Intentional Radiators

§ 2.1053 Radiated Spurious Emissions

Test Requirement(s): § 2.1053 Measurements required: Field strength of spurious radiation.

§ 2.1053 (a) Measurements shall be made to detect spurious emissions that may be radiated directly from the cabinet, control circuits, power leads, or intermediate circuit elements under normal conditions of installation and operation. Curves or equivalent data shall be supplied showing the magnitude of each harmonic and other spurious emission. For this test, single sideband, independent sideband, and controlled carrier transmitters shall be modulated under the conditions specified in paragraph (c) of § 2.1049, as appropriate. For equipment operating on frequencies below 890 MHz, an open field test is normally required with the measuring instrument antenna located in the far-field at all test frequencies. In the event it is either impractical or impossible to make open field measurements (e.g. a broadcast transmitter installed in a building) measurements will be accepted of the equipment as installed. Such measurements must be accompanied by a description of the site where the measurements were made showing the location of any possible source of reflections which might distort the field strength measurements. Information submitted shall include the relative radiated power of each spurious emission with reference to the rated power output of the transmitter, assuming all emissions are radiated from half-wave dipole antennas.

§ 2.1053 (b): The measurements specified in paragraph (a) of this section shall be made for the following equipment:

- (1) Those in which the spurious emissions are required to be 60 dB or more below the mean power of the transmitter.
- (2) All equipment operating on frequencies higher than 25 MHz.
- (3) All equipment where the antenna is an integral part of, and attached directly to the transmitter.
- (4) Other types of equipment as required, when deemed necessary by the Commission.

Test Procedures: As required by 47 CFR 2.1053, *field strength of radiated spurious measurements* was made in accordance with the procedures of TIA/EIA-603-A-2001 "Land Mobile FM or PM Communications Equipment Measurement and Performance Standards".

Radiated emission measurements were performed inside a 3 meter semi-anechoic chamber. The EUT's RF ports were terminated to 50ohm load. The EUT was set to transmit at the low, mid and high channels of the transmitter frequency range at its maximum power level. The EUT was rotated about 360⁰ and the receiving antenna scanned from 1-4m in order to capture the maximum emission. The plots are corrected for cable loss, antenna correction factor, and distance correction. The field strength was mathematically corrected to an E.I.R.P. Harmonic emissions up to the 10th or 40GHz, which ever was the lesser, were investigated.

Test Results: The EUT complies with the requirements of this section for downlink. The Uplink is via fiber optic cable.

Test Engineer: Dusmantha Tennakoon

Test Date(s): 02/24/11

Electromagnetic Compatibility Criteria for Intentional Radiators

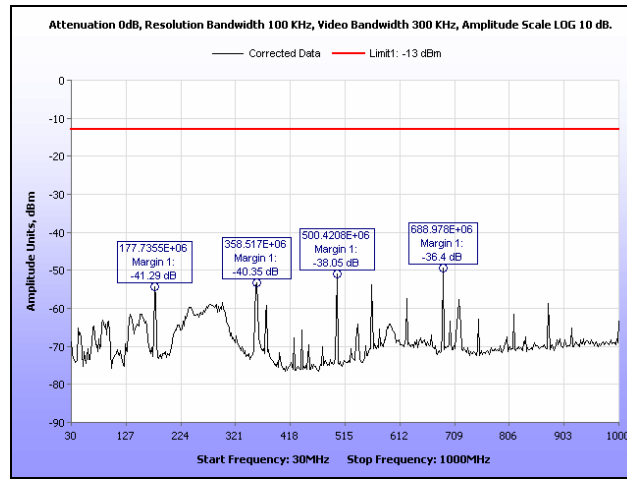

Plot 77. 1930.67 MHz, Radiated Spurious Emissions, Downlink, 30 MHz – 1 GHz

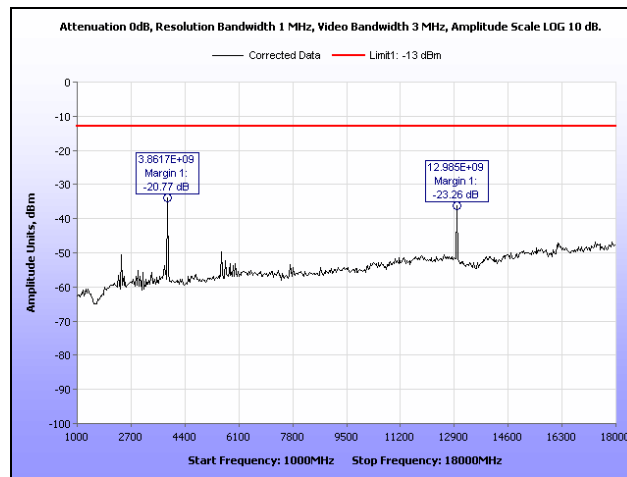

Plot 78. 1930.67 MHz, Radiated Spurious Emissions, Downlink, 1 GHz – 18 GHz

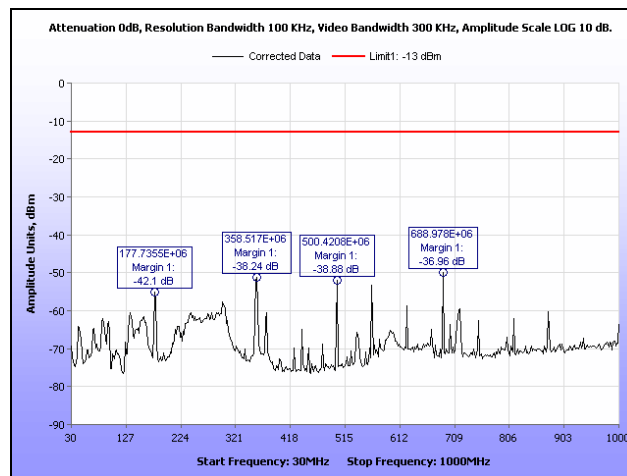

Plot 79. 1962 MHz, Radiated Spurious Emissions, Downlink, 30 MHz – 1 GHz

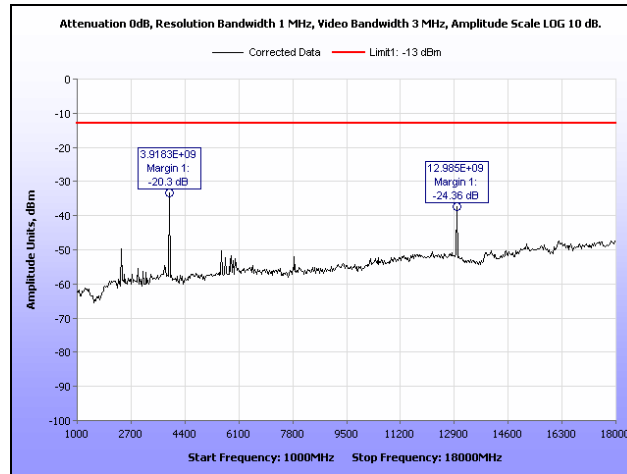

Plot 80. 1962 MHz, Radiated Spurious Emissions, Downlink, 1 GHz – 18 GHz

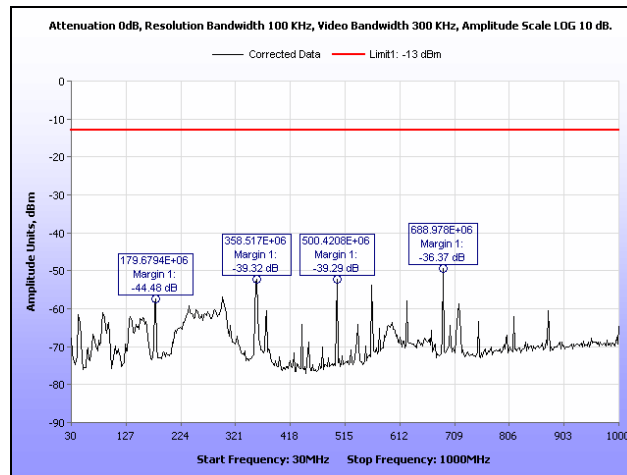

Plot 81. 1994.33 MHz, Radiated Spurious Emissions, Downlink, 30 MHz – 1 GHz

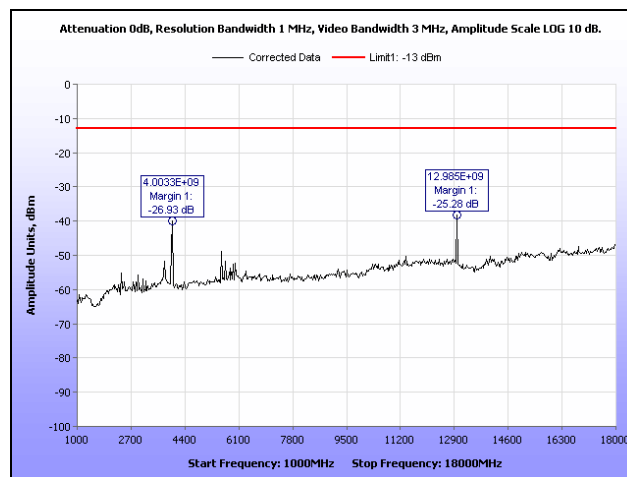

Plot 82. 1994.33 MHz, Radiated Spurious Emissions, Downlink, 1 GHz – 18 GHz

Electromagnetic Compatibility Criteria for Intentional Radiators

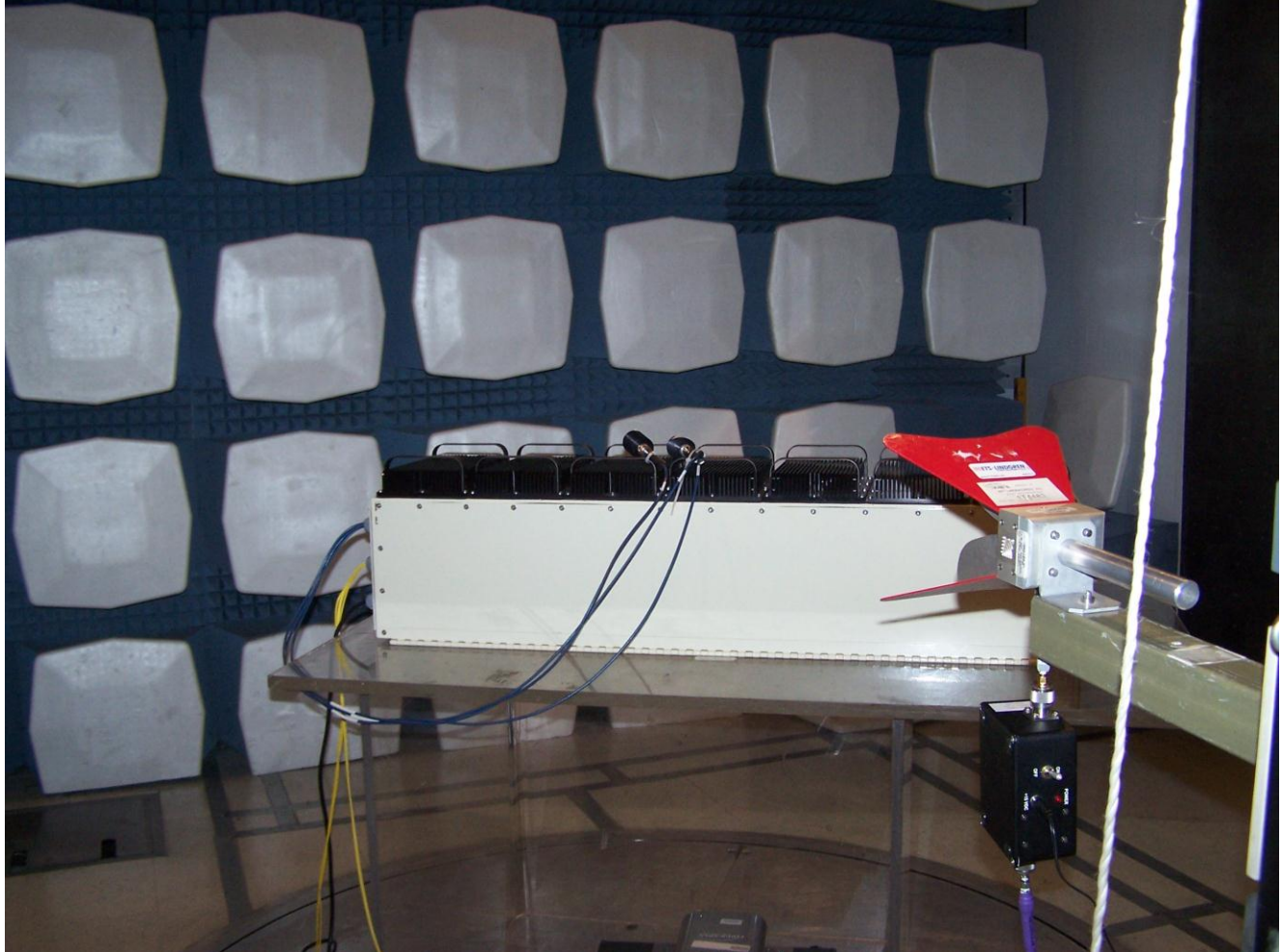

Photograph 5. Radiated Spurious, Test Setup, Above 1 GHz

Electromagnetic Compatibility Criteria for Intentional Radiators

§ 2.1051 Spurious Emissions at Antenna Terminals

Test Requirement(s): § 2.1051 **Measurements required: Spurious emissions at antenna terminals:** The radio frequency voltage or powers generated within the equipment and appearing on a spurious frequency shall be checked at the equipment output terminals when properly loaded with a suitable artificial antenna. Curves or equivalent data shall show the magnitude of each harmonic and other spurious emission that can be detected when the equipment is operated under the conditions specified in § 2.1049 as appropriate. The magnitude of spurious emissions which are attenuated more than 20 dB below the permissible value need not be specified.

§24.238 Emission limitations for Broadband PCS equipment: The rules in this section govern the spectral characteristics of emissions in the Broadband Personal Communications Service.

§ 24.238 (a) Out of band emissions. The power of any emission outside of the authorized operating frequency ranges must be attenuated below the transmitting power (P) by a factor of at least $43 + 10 \log(P)$ dB.

Test Procedures: The EUT's RF Output Power port was connected to a spectrum analyzer through an attenuator. The EUT was set to transmit and the low, mid, and high channels.

Test Results: The EUT complies with the requirements of this section.

Test Engineer(s): Dusmantha Tennakoon

Test Date(s): 02/24/11

Spurious Emissions at Antenna Terminals Test Results

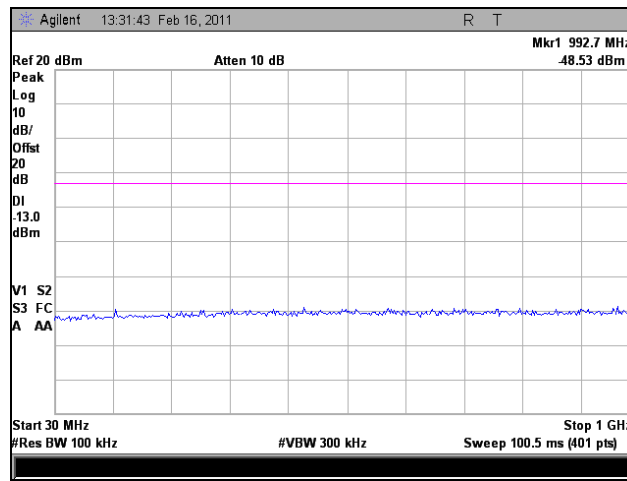

Plot 83. 1930.67 MHz, Conducted Spurious Emissions, Downlink, EVDO, 30 MHz – 1 GHz

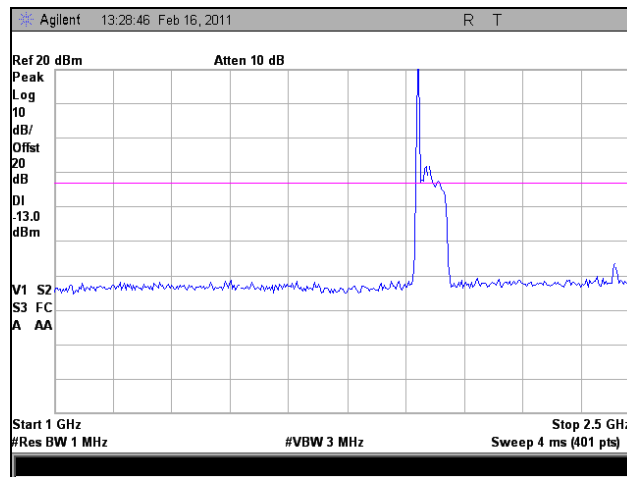

Plot 84. 1930.67 MHz, Conducted Spurious Emissions, Downlink, EVDO, 1 GHz – 2.5 GHz

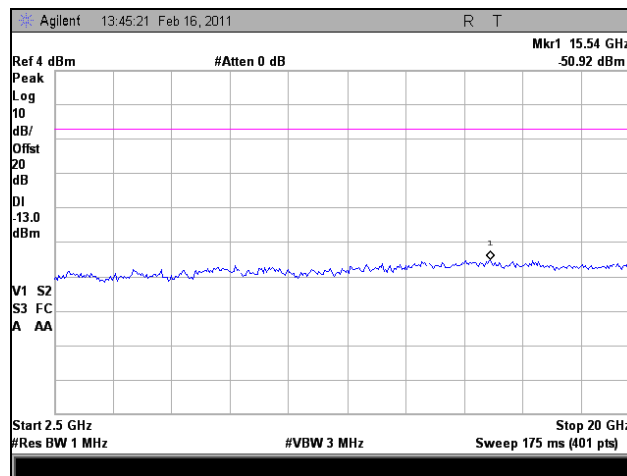

Plot 85. 1930.67 MHz, Conducted Spurious Emissions, Downlink, EVDO, 2.5 GHz – 20 GHz

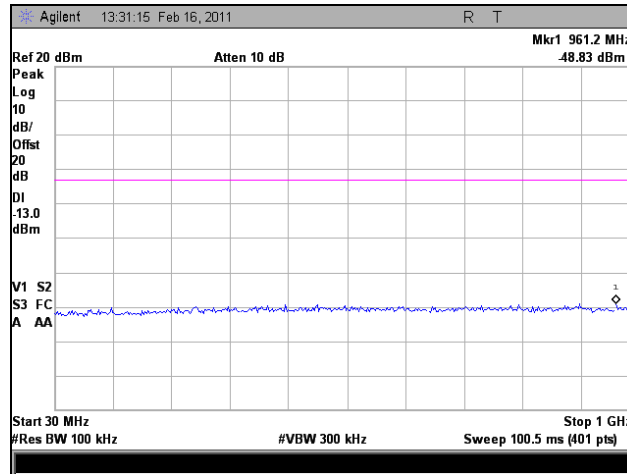

Plot 86. 1962 MHz, Conducted Spurious Emissions, Downlink, EVDO, 30 MHz – 1 GHz

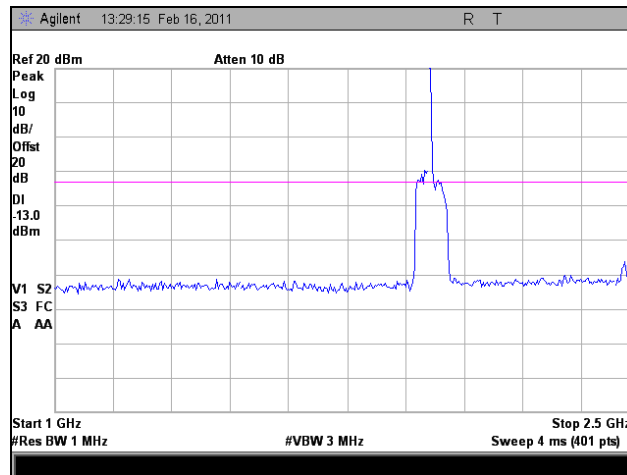

Plot 87. 1962 MHz, Conducted Spurious Emissions, Downlink, EVDO, 1 GHz – 2.5 GHz

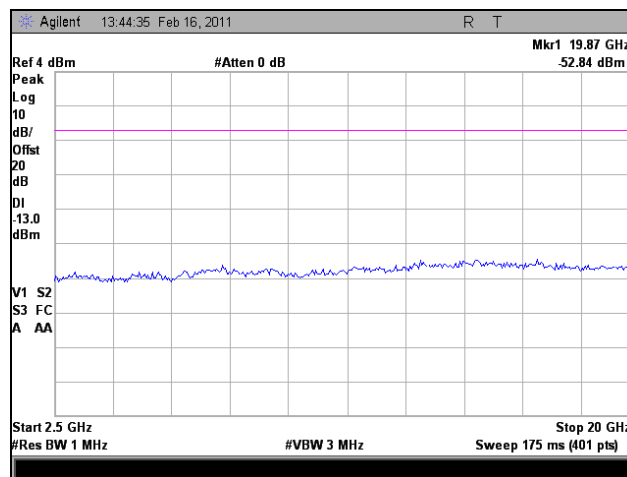

Plot 88. 1962 MHz, Conducted Spurious Emissions, Downlink, EVDO, 2.5 GHz – 20 GHz

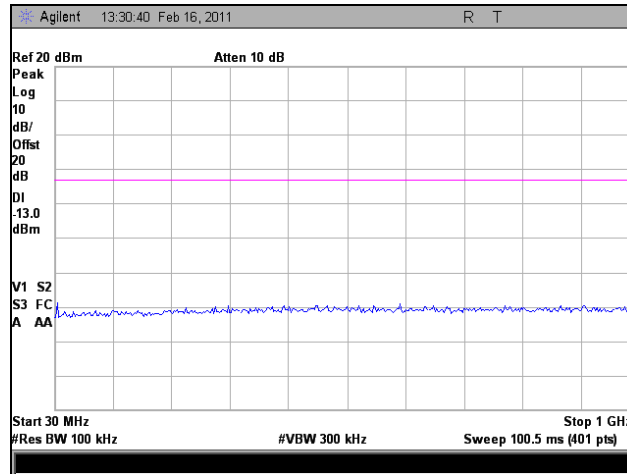

Plot 89. 1994.33 MHz, Conducted Spurious Emissions, Downlink, EVDO, 30 MHz – 1 GHz

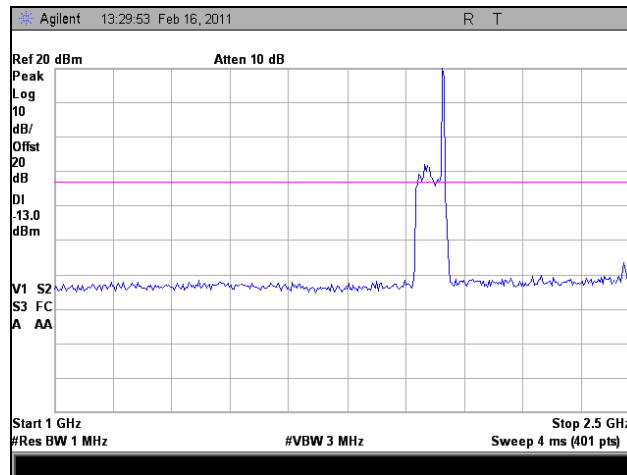

Plot 90. 1994.33 MHz, Conducted Spurious Emissions, Downlink, EVDO, 1 GHz – 2.5 GHz

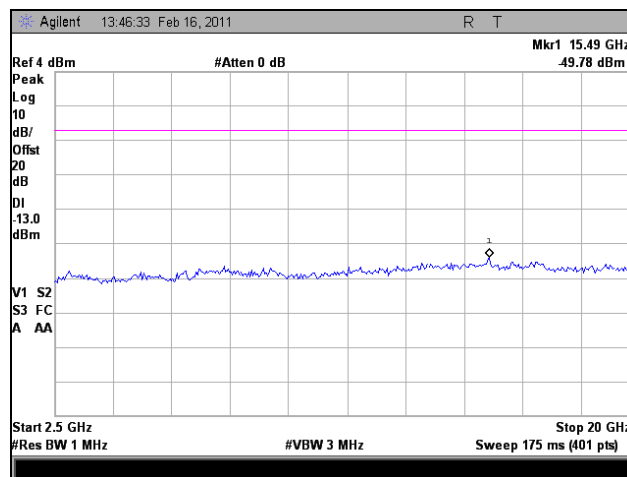

Plot 91. 1994.33 MHz, Conducted Spurious Emissions, Downlink, EVDO, 2.5 GHz – 20 GHz

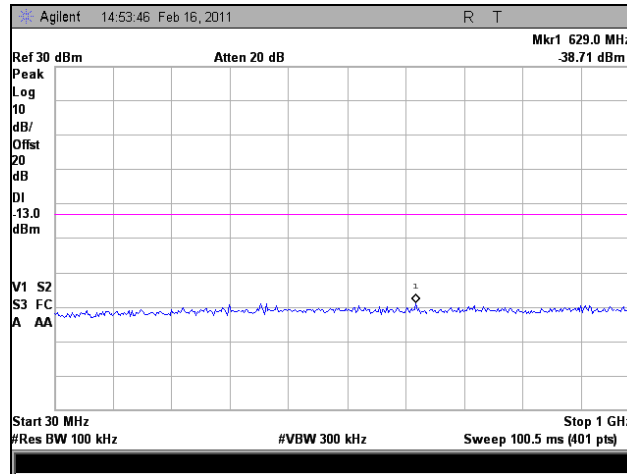

Plot 92. 1930.7 MHz, Conducted Spurious Emissions, Downlink, LTE, 30 MHz – 1 GHz

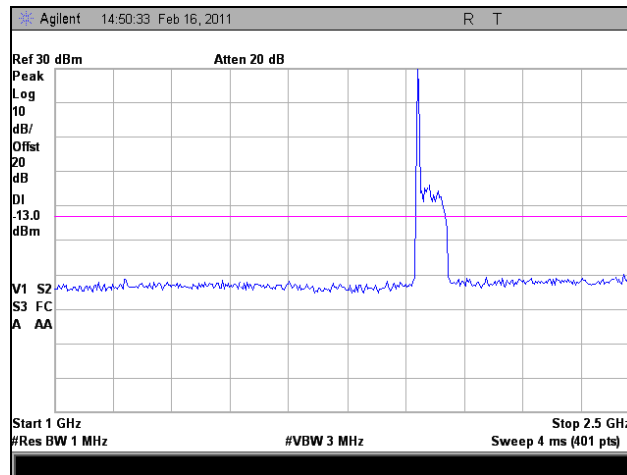

Plot 93. 1930.7 MHz, Conducted Spurious Emissions, Downlink, LTE, 1 GHz – 2.5 GHz

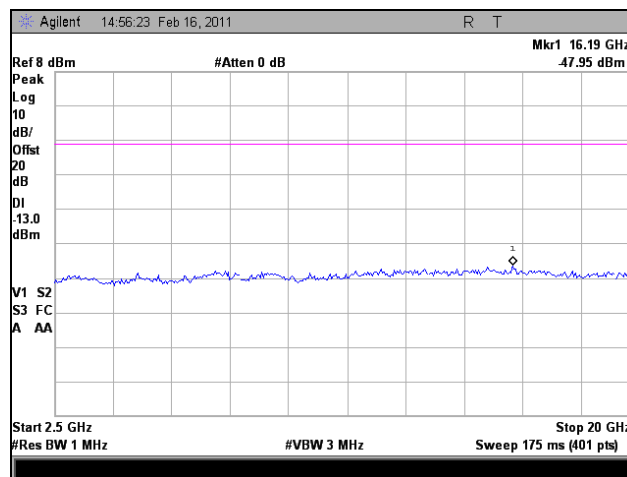

Plot 94. 1930.7 MHz, Conducted Spurious Emissions, Downlink, LTE, 2.5 GHz – 20 GHz

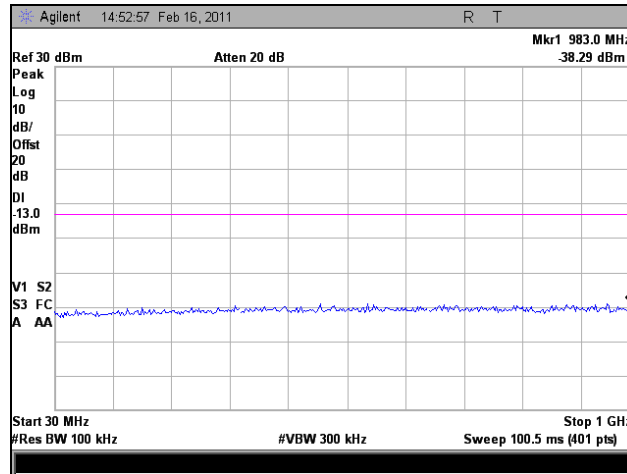

Plot 95. 1962 MHz, Conducted Spurious Emissions, Downlink, LTE, 30 MHz – 1 GHz

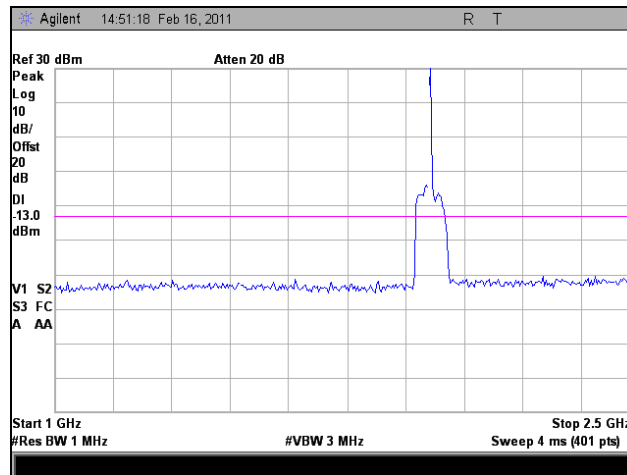

Plot 96. 1962 MHz, Conducted Spurious Emissions, Downlink, LTE, 1 GHz – 2.5 GHz

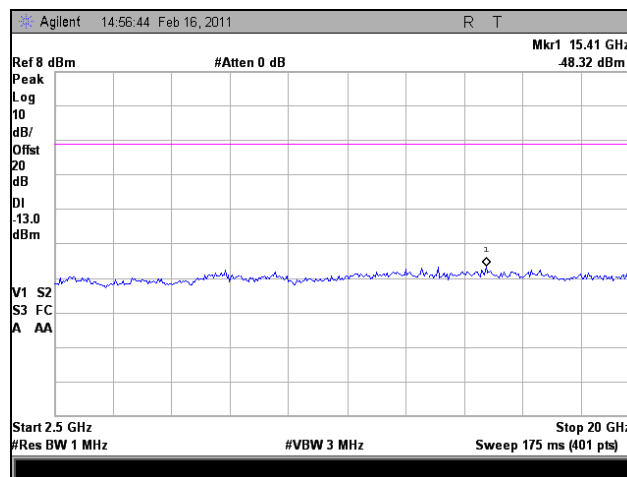

Plot 97. 1962 MHz, Conducted Spurious Emissions, Downlink, LTE, 2.5 GHz – 20 GHz

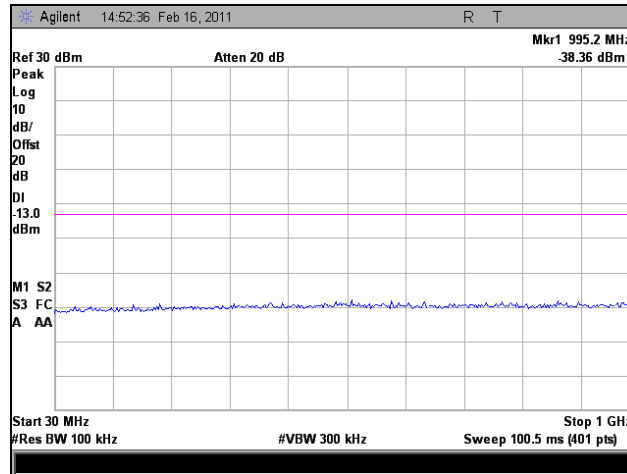

Plot 98. 1994.3 MHz, Conducted Spurious Emissions, Downlink, LTE, 30 MHz – 1 GHz

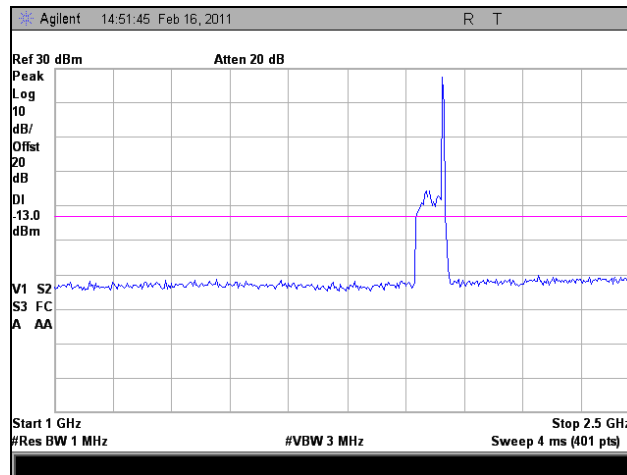

Plot 99. 1994.3 MHz, Conducted Spurious Emissions, Downlink, LTE, 1 GHz – 2.5 GHz

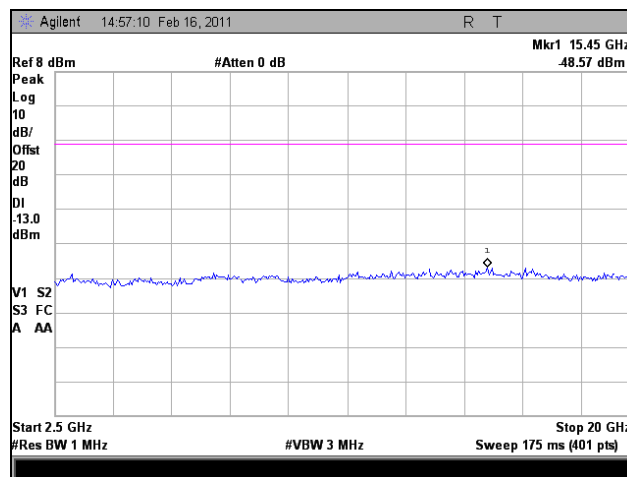

Plot 100. 1994.3 MHz, Conducted Spurious Emissions, Downlink, LTE, 2.5 GHz – 20 GHz

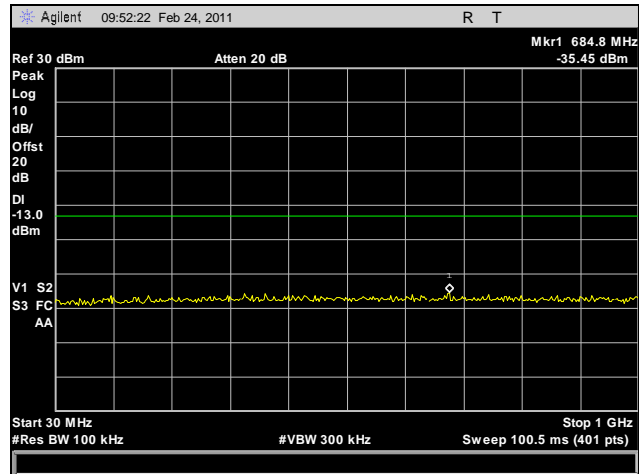

Plot 101. 1930.125 MHz, Conducted Spurious Emissions, Downlink, GSM, 30 MHz – 1 GHz

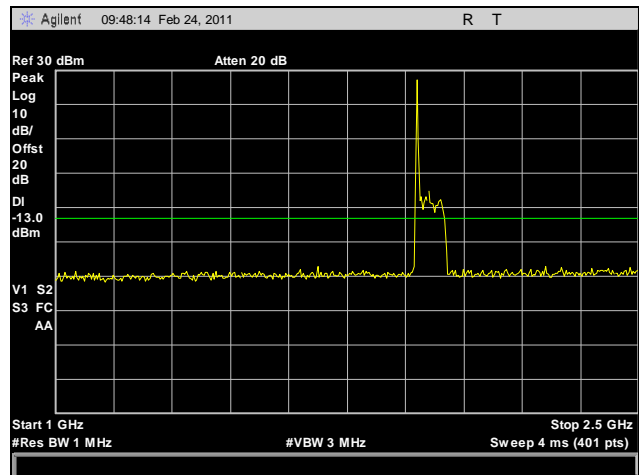

Plot 102. 1930.125 MHz, Conducted Spurious Emissions, Downlink, GSM, 1 GHz – 2.5 GHz

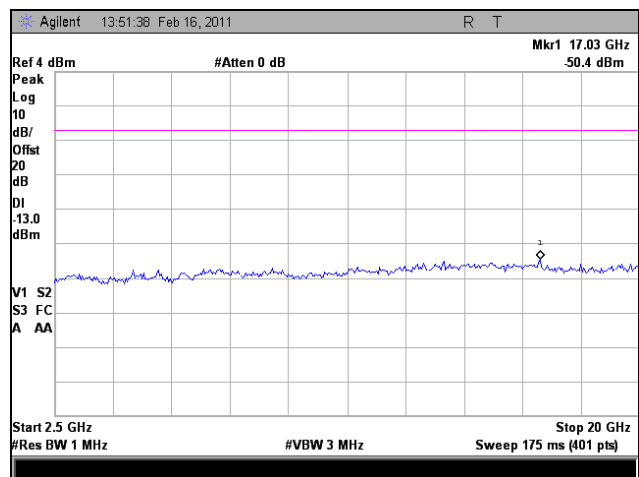

Plot 103. 1930.125 MHz, Conducted Spurious Emissions, Downlink, GSM, 2.5 GHz – 20 GHz

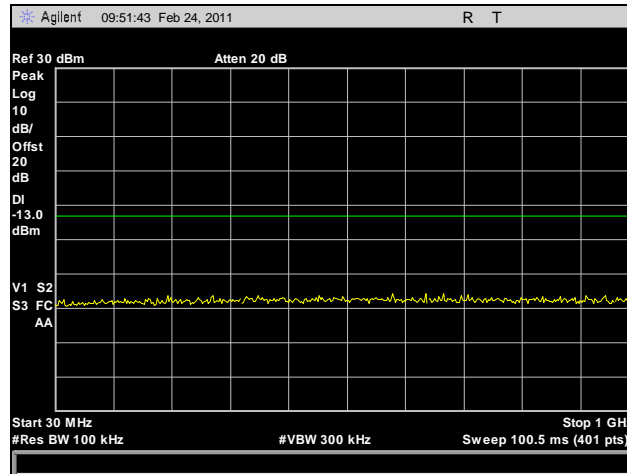

Plot 104. 1962 MHz, Conducted Spurious Emissions, Downlink, GSM, 30 MHz – 1 GHz

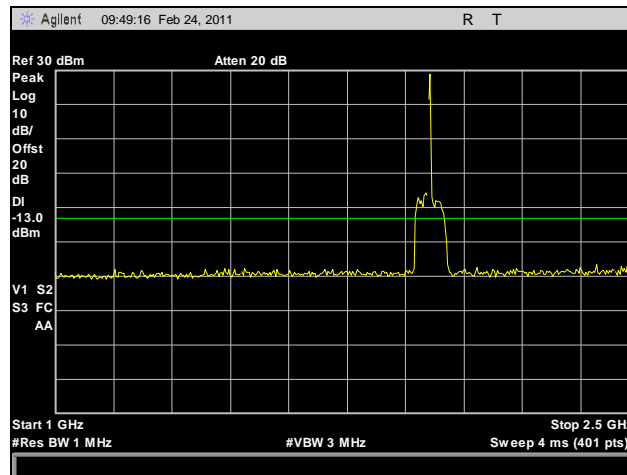

Plot 105. 1962 MHz, Conducted Spurious Emissions, Downlink, GSM, 1 GHz – 2.5 GHz

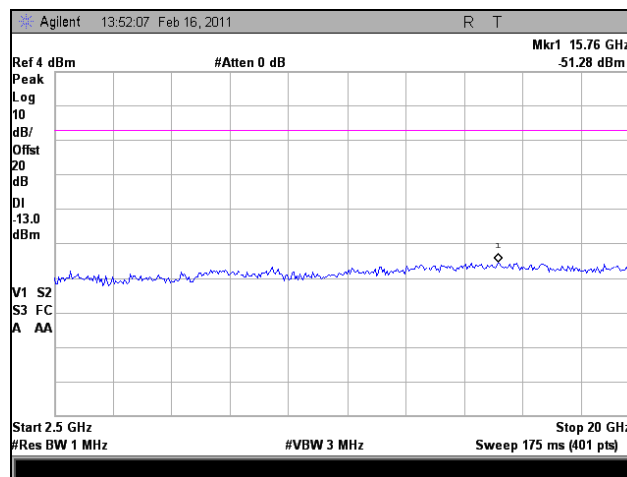

Plot 106. 1962 MHz, Conducted Spurious Emissions, Downlink, GSM, 2.5 GHz – 20 GHz

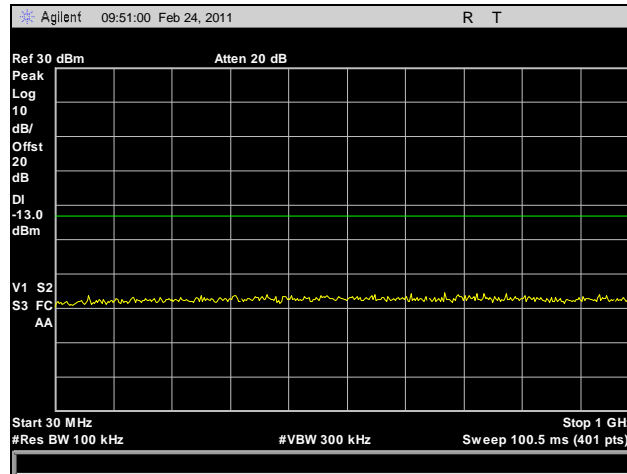

Plot 107. 1994.875 MHz, Conducted Spurious Emissions, Downlink, GSM, 30 MHz – 1 GHz

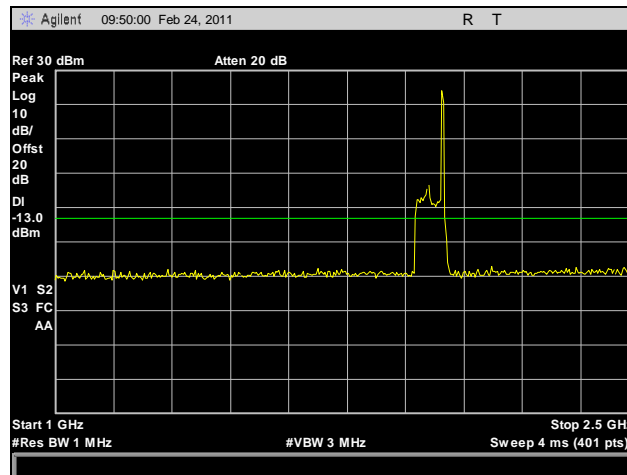

Plot 108. 1994.875 MHz, Conducted Spurious Emissions, Downlink, GSM, 1 GHz – 2.5 GHz

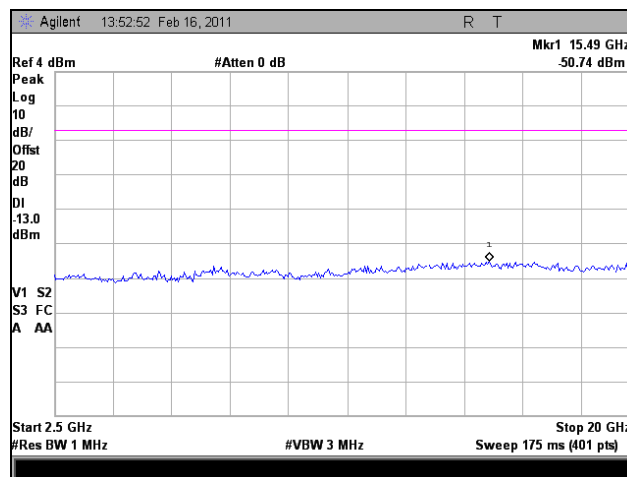

Plot 109. 1994.875 MHz, Conducted Spurious Emissions, Downlink, GSM, 2.5 GHz – 20 GHz

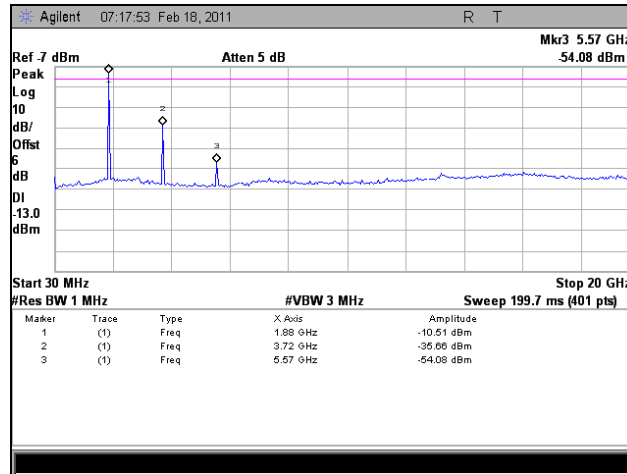

Plot 110. 1950.67 MHz, Conducted Spurious Emissions, Uplink, EVDO, 30 MHz – 20 GHz

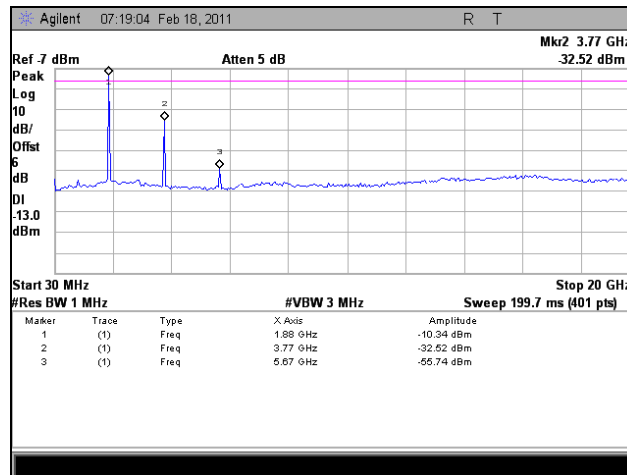

Plot 111. 1885 MHz, Conducted Spurious Emissions, Uplink, EVDO, 30 MHz – 20 GHz

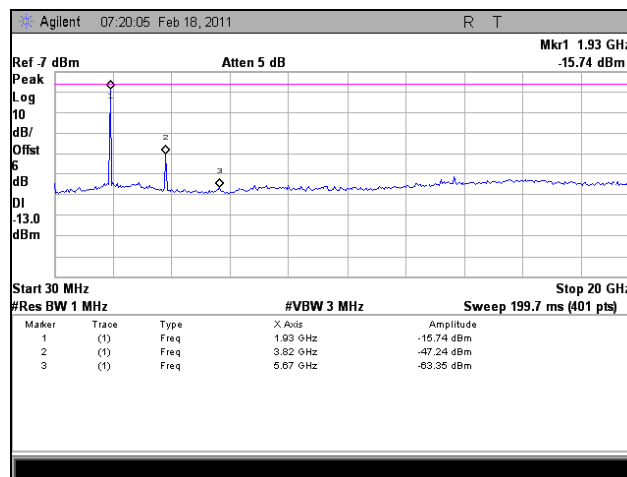

Plot 112. 1914.33 MHz, Conducted Spurious Emissions, Uplink, EVDO, 30 MHz – 20 GHz

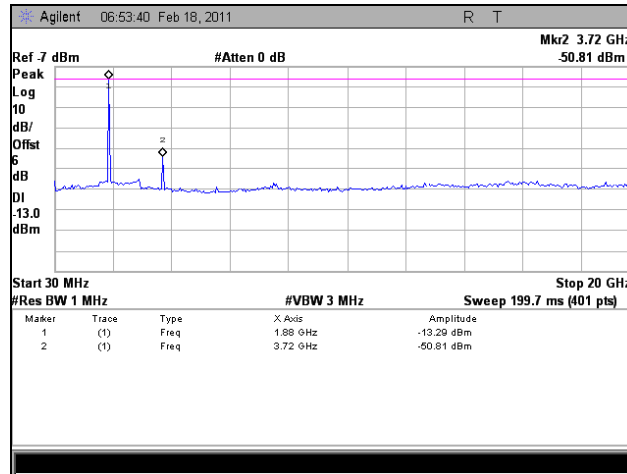

Plot 113. 1950.7 MHz, Conducted Spurious Emissions, Uplink, LTE, 30 MHz – 20 GHz

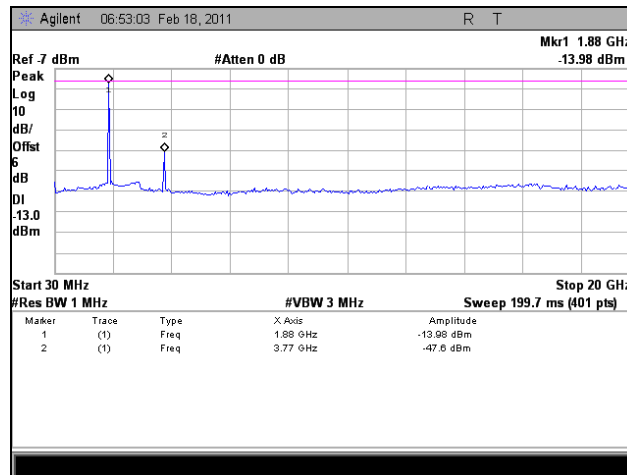

Plot 114. 1885 MHz, Conducted Spurious Emissions, Uplink, LTE, 30 MHz – 20 GHz

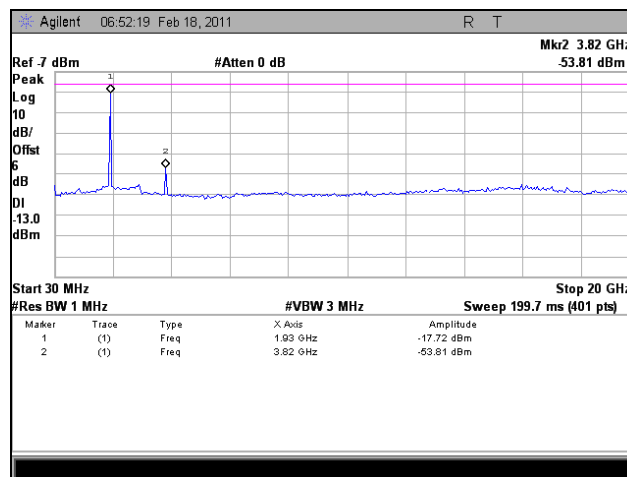

Plot 115. 1914.3 MHz, Conducted Spurious Emissions, Uplink, LTE, 30 MHz – 20 GHz

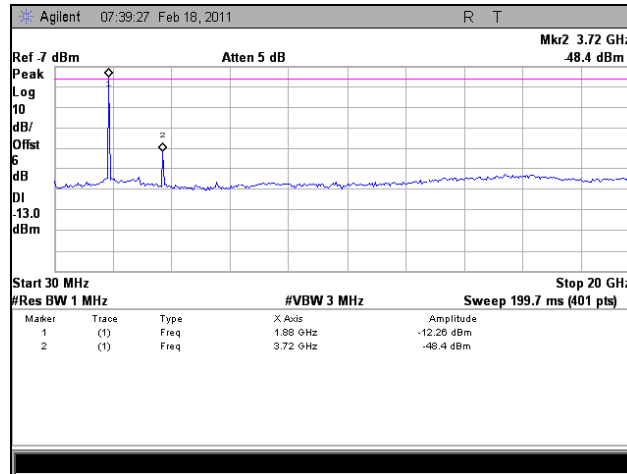

Plot 116. 1950.125 MHz, Conducted Spurious Emissions, Uplink, GSM, 30 MHz – 20 GHz

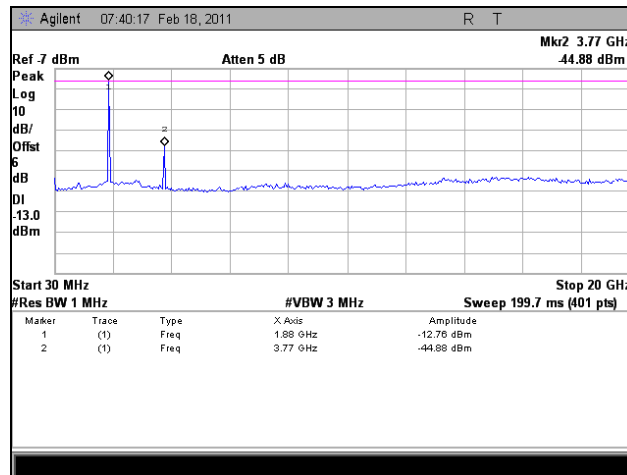

Plot 117. 1885 MHz, Conducted Spurious Emissions, Uplink, GSM, 30 MHz – 20 GHz

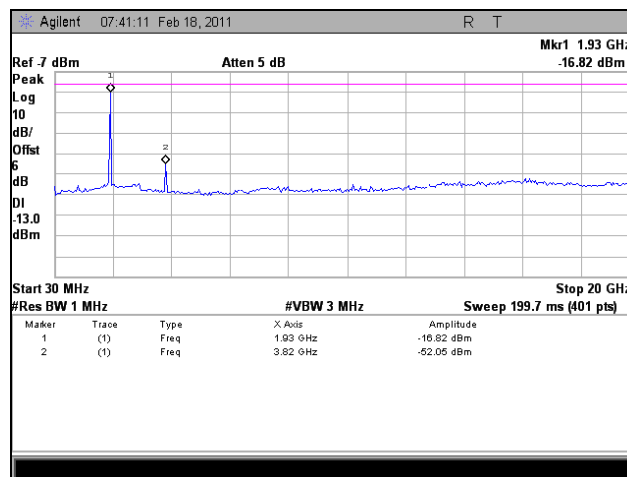

Plot 118. 1914.875 MHz, Conducted Spurious Emissions, Uplink, GSM, 30 MHz – 20 GHz

Electromagnetic Compatibility Criteria for Intentional Radiators

Frequency Stability

Test Requirement(s): §2.1055

Test Procedures: As required by 47 CFR 2.1055, *Frequency Stability measurements* were made at the RF output terminals using a direct connect to a Spectrum Analyzer.

The EUT was placed in the Environmental Chamber and support equipments are outside of the chamber. The EUT was set to transmitter at its low channel and at its high channel. The frequency drift was investigated for every 10°C increment until the unit was stabilized. Plots were taken with the temperature range of -30 to 50°C.

The RF output port was connected directly to the spectrum analyzer. A marker was placed at the band edge of both the low and the high channels. Measurements were made to ensure that the carrier did not drift outside of its intended band.

Voltage supplied to EUT is 120 VAC reference temperature was done at 20°C. The voltage was varied by $\pm 15\%$ of nominal

Test Results: Equipment is not applicable with Section 2.1055.

Electromagnetic Compatibility Criteria for Intentional Radiators

RSS-GEN Receiver Spurious Emissions Requirements

Test Requirements: The following receiver spurious emission limits shall be complied with:

- (a) If a radiated measurement is made, all spurious emissions shall comply with the limits of Table 14.

Spurious Frequency (MHz)	Field Strength (microvolt/m at 3 metres)
30 – 88	100
88 – 216	150
216 – 960	200
Above 960	500

Table 14. Spurious Emission Limits for Receivers

- (b) If a conducted measurement is made, no spurious output signals appearing at the antenna terminals shall exceed 2 nanowatts per any 4 kHz spurious frequency in the band 30-1000 MHz, or 5 nanowatts above 1 GHz.

Test Procedures: Measurements were made radiated.

Test Results: Equipment is compliant with the Receiver Spurious Emissions Requirements of RSS-GEN. Measurements were made radiated. Highest measured receiver spurs is 47.92 dBuV/m @ 3m.

Test Engineer(s): Dusmantha Tennakoon

Test Date(s): 02/24/11

Intermodulation

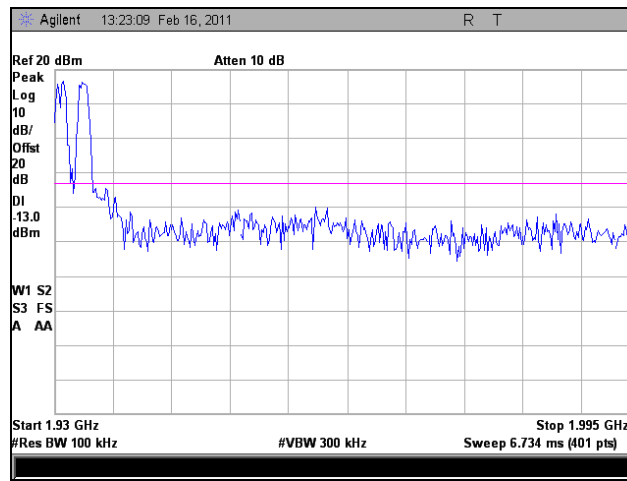

Plot 119. Intermodulation, Downlink, EVDO, Low Channel

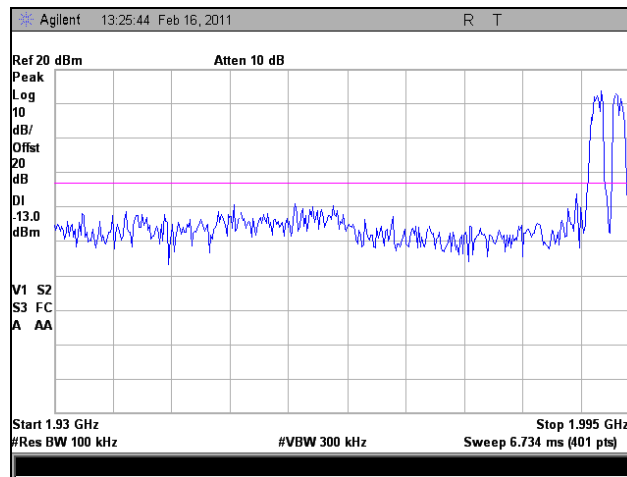

Plot 120. Intermodulation, Downlink, EVDO, High Channel

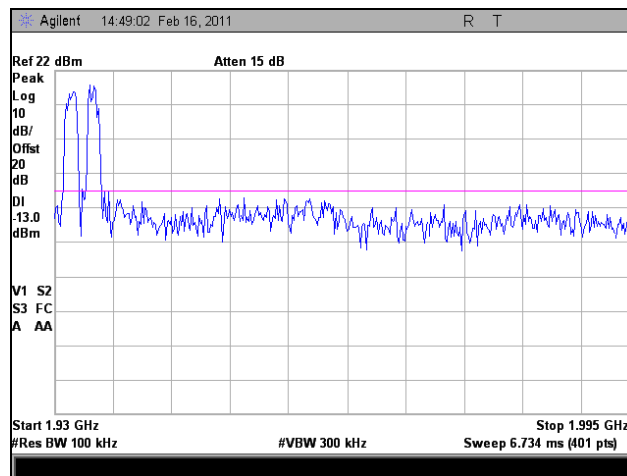

Plot 121. Intermodulation, Downlink, LTE, Low Channel

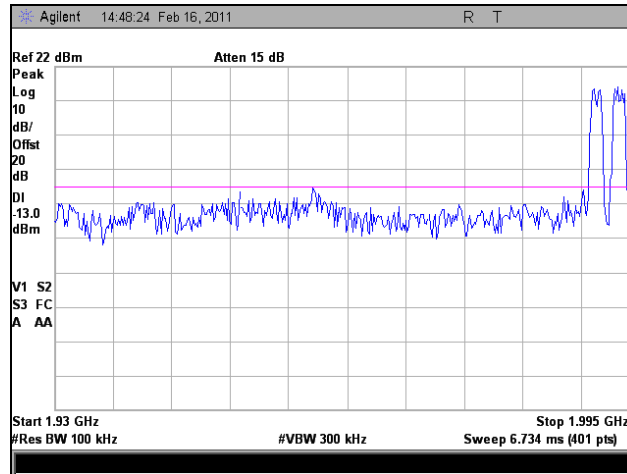

Plot 122. Intermodulation, Downlink, LTE, High Channel

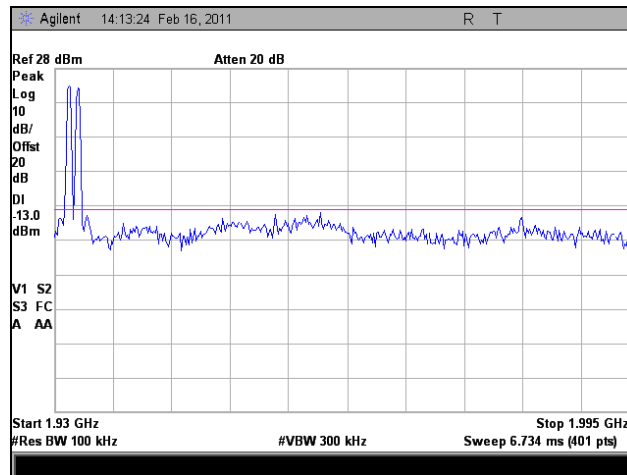

Plot 123. Intermodulation, Downlink, GSM, Low Channel

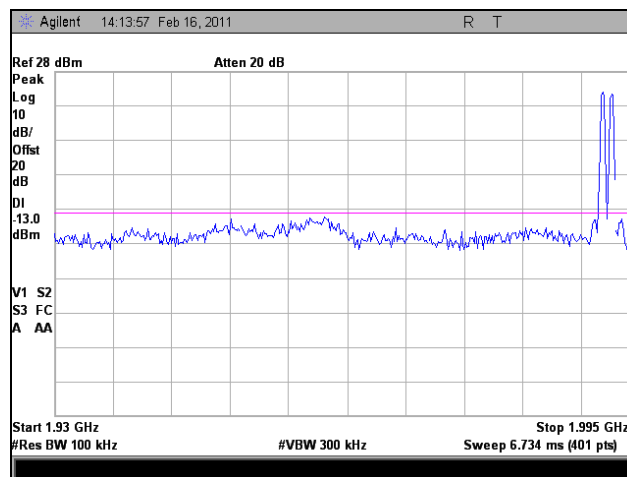

Plot 124. Intermodulation, Downlink, GSM, High Channel

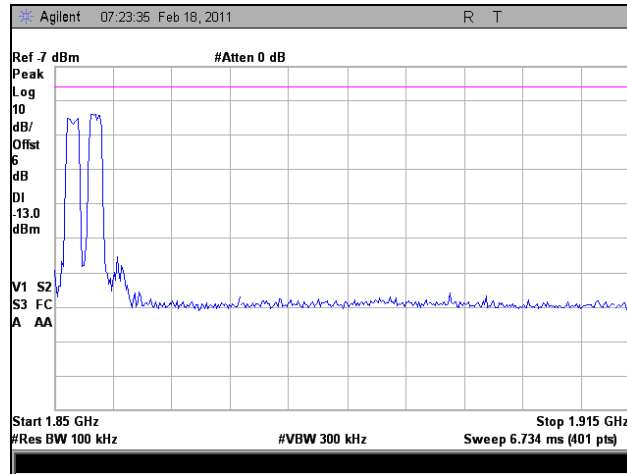

Plot 125. Intermodulation, Uplink, EVDO, Low Channel

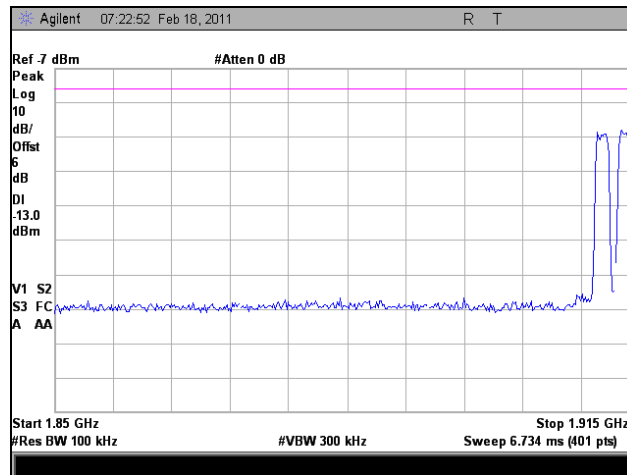

Plot 126. Intermodulation, Uplink, EVDO, High Channel

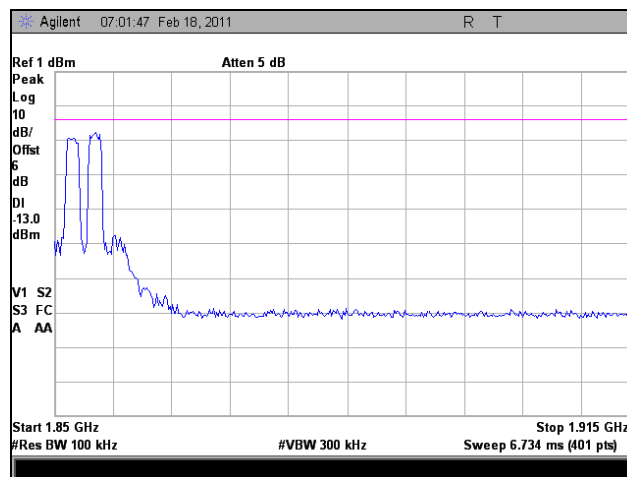

Plot 127. Intermodulation, Uplink, LTE, Low Channel

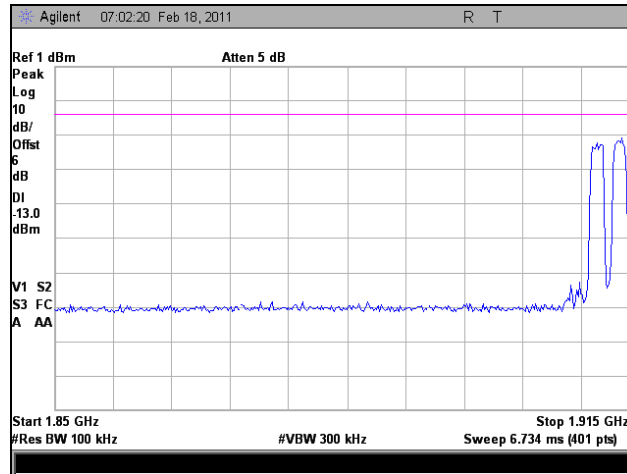

Plot 128. Intermodulation, Uplink, LTE, High Channel

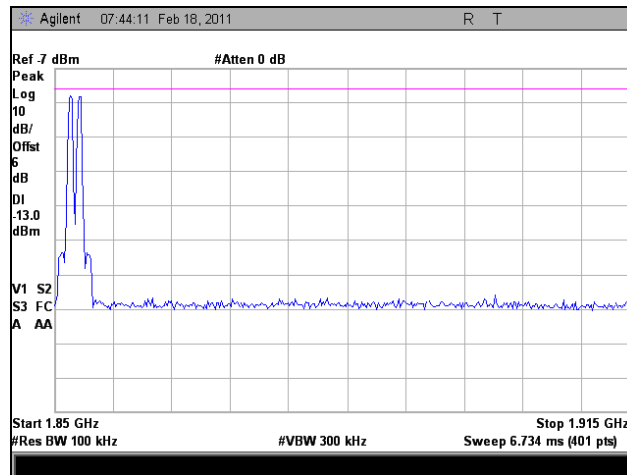

Plot 129. Intermodulation, Uplink, GSM, Low Channel

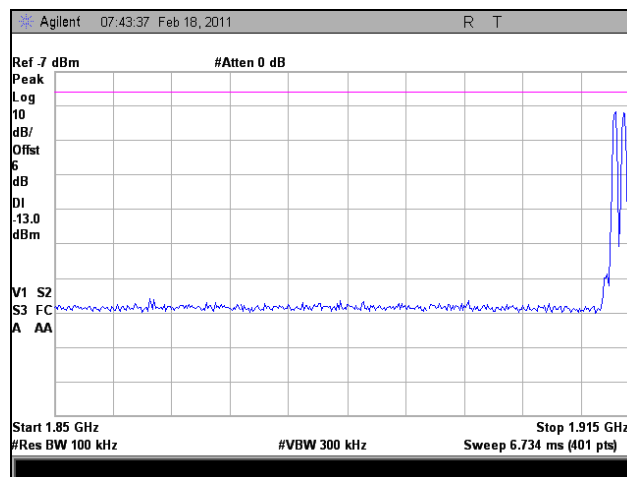

Plot 130. Intermodulation, Uplink, GSM, High Channel

Filter Response

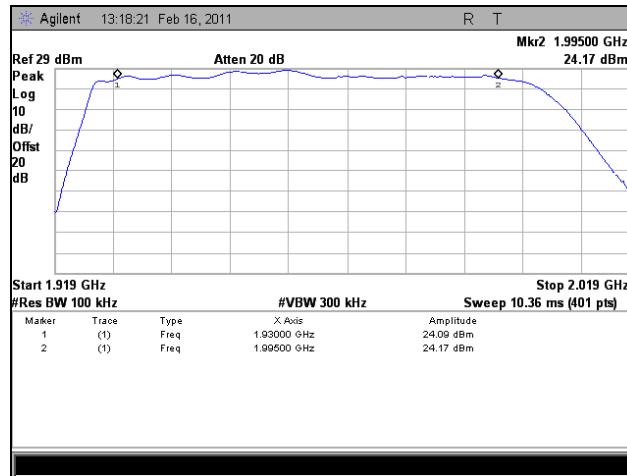

Plot 131. Filter Response, Downlink

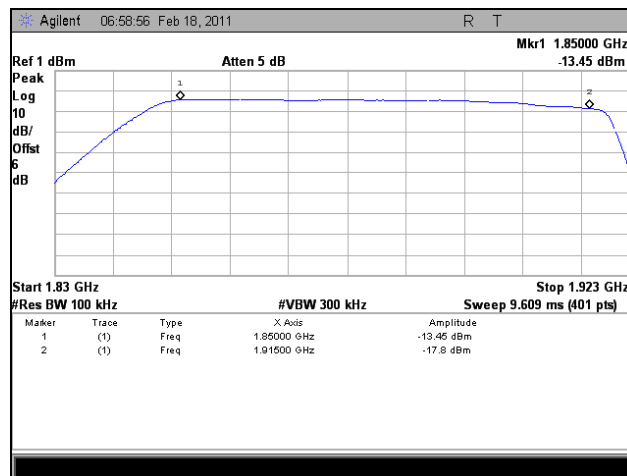

Plot 132. Filter Response, Uplink



IV. Test Equipment



Test Equipment

Calibrated test equipment utilized during testing was maintained in a current state of calibration per the requirements of ANSI/NCSL Z540-1-1994 and ANSI/ISO/IEC 17025:2000.

MET #	Equipment	Manufacturer	Model	Cal Date	Cal Due
1T4621	ESA-E SERIES SPECTRUM ANALYZER	AGILENT	E4402B	05/10/2010	05/10/2011
1T4592	RF FILTER KIT	VARIOUS	N/A	SEE NOTE	
1T4414	MICROWAVE PRE-AMPLIFIER	A.H. SYSTEMS	PAM-0118	SEE NOTE	
1T4409	EMI RECEIVER	ROHDE & SCHWARZ	ESIB7	05/25/2010	05/25/2011
1T4299	SIGNAL GENERATOR	HEWLETT PACKARD	E4432B	01/04/2011	01/04/2012
1T4751	ANTENNA - BILOG	SUNOL SCIENCES	JB6	11/3/2010	11/3/2011
1T4483	ANTENNA; HORN	ETS-LINDGREN	3117	06/08/2010	06/08/2011
1T4300	SEMI-ANECHOIC CHAMBER # 1	EMC TEST SYSTEMS	NONE	08/23/2010	08/23/2013

Table 15. Test Equipment List

Note: Functionally tested equipment is verified using calibrated instrumentation at the time of testing.



V. Certification & User's Manual Information



Certification & User's Manual Information

A. Certification Information

The following is extracted from Title 47 of the Code of Federal Regulations, Part 2, Subpart I — Marketing of Radio frequency devices:

§ 2.801 Radio-frequency device defined.

As used in this part, a radio-frequency device is any device which in its operation is capable of Emitting radio-frequency energy by radiation, conduction, or other means. Radio- frequency devices include, but are not limited to:

- (a) The various types of radio communication transmitting devices described throughout this chapter.
- (b) *The incidental, unintentional and intentional radiators defined in Part 15 of this chapter.*
- (c) The industrial, scientific, and medical equipment described in Part 18 of this chapter.
- (d) Any part or component thereof which in use emits radio-frequency energy by radiation, conduction, or other means.

§ 2.803 Marketing of radio frequency devices prior to equipment authorization.

- (a) Except as provided elsewhere in this chapter, no person shall sell or lease, or offer for sale or lease (including advertising for sale or lease), or import, ship or distribute for the purpose of selling or leasing or offering for sale or lease, any radio frequency device unless:
 - (1) In the case of a device subject to certification, such device has been authorized by the Commission in accordance with the rules in this chapter and is properly identified and labeled as required by §2.925 and other relevant sections in this chapter; or
 - (2) In the case of a device that is not required to have a grant of equipment authorization issued by the Commission, but which must comply with the specified technical standards prior to use, such device also complies with all applicable administrative (including verification of the equipment or authorization under a Declaration of Conformity, where required), technical, labeling and identification requirements specified in this chapter.
- (d) Notwithstanding the provisions of paragraph (a) of this section, the offer for sale solely to business, commercial, industrial, scientific or medical users (but not an offer for sale to other parties or to end users located in a residential environment) of a radio frequency device that is in the conceptual, developmental, design or pre-production stage is permitted prior to equipment authorization or, for devices not subject to the equipment authorization requirements, prior to a determination of compliance with the applicable technical requirements *provided* that the prospective buyer is advised in writing at the time of the offer for sale that the equipment is subject to the FCC rules and that the equipment will comply with the appropriate rules before delivery to the buyer or to centers of distribution.



- (e)(1) Notwithstanding the provisions of paragraph (a) of this section, prior to equipment authorization or determination of compliance with the applicable technical requirements any radio frequency device may be operated, but not marketed, for the following purposes and under the following conditions:
- (i) *Compliance testing;*
 - (ii) Demonstrations at a trade show provided the notice contained in paragraph (c) of this section is displayed in a conspicuous location on, or immediately adjacent to, the device;
 - (iii) Demonstrations at an exhibition conducted at a business, commercial, industrial, scientific or medical location, but excluding locations in a residential environment, provided the notice contained in paragraphs (c) or (d) of this section, as appropriate, is displayed in a conspicuous location on, or immediately adjacent to, the device;
 - (iv) Evaluation of product performance and determination of customer acceptability, provided such operation takes place at the manufacturer's facilities during developmental, design or pre-production states; or
 - (v) Evaluation of product performance and determination of customer acceptability where customer acceptability of a radio frequency device cannot be determined at the manufacturer's facilities because of size or unique capability of the device, provided the device is operated at a business, commercial, industrial, scientific or medical user's site, but not at a residential site, during the development, design or pre-production stages.
- (e)(2) For the purpose of paragraphs (e)(1)(iv) and (e)(1)(v) of this section, the term *manufacturer's facilities* includes the facilities of the party responsible for compliance with the regulations and the manufacturer's premises, as well as the facilities of other entities working under the authorization of the responsible party in connection with the development and manufacture, but not the marketing, of the equipment.
- (f) For radio frequency devices subject to verification and sold solely to business, commercial, industrial, scientific and medical users (excluding products sold to other parties or for operation in a residential environment), parties responsible for verification of the devices shall have the option of ensuring compliance with the applicable technical specifications of this chapter at each end user's location after installation, provided that the purchase or lease agreement includes a proviso that such a determination of compliance be made and is the responsibility of the party responsible for verification of the equipment.



Certification & User's Manual Information

The following is extracted from Title 47 of the Code of Federal Regulations, Part 2, Subpart J — Equipment Authorization Procedures:

§ 2.901 Basis and Purpose

- (a) In order to carry out its responsibilities under the Communications Act and the various treaties and international regulations, and in order to promote efficient use of the radio spectrum, the Commission has developed technical standards for radio frequency equipment and parts or components thereof. The technical standards applicable to individual types of equipment are found in that part of the rules governing the service wherein the equipment is to be operated.¹ *In addition to the technical standards provided, the rules governing the service may require that such equipment be verified by the manufacturer or importer, be authorized under a Declaration of Conformity, or receive an equipment authorization from the Commission by one of the following procedures: certification or registration.*
- (b) The following sections describe the verification procedure, the procedure for a Declaration of Conformity, and the procedures to be followed in obtaining certification from the Commission and the conditions attendant to such a grant.

§ 2.907 Certification.

- (a) Certification is an equipment authorization issued by the Commission, based on representation and test data submitted by the applicant.
- (b) Certification attaches to all units subsequently marketed by the grantee which are identical (see Section 2.908) to the sample tested except for permissive changes or other variations authorized by the Commission pursuant to Section 2.1043.

¹ In this case, the equipment is subject to the rules of Part 15. More specifically, the equipment falls under Subpart B (of Part 15), which deals with unintentional radiators.



Certification & User's Manual Information

§ 2.948 Description of measurement facilities.

- (a) Each party making measurements of equipment that is subject to an equipment authorization under Part 15 or Part 18 of this chapter, regardless of whether the measurements are filed with the Commission or kept on file by the party responsible for compliance of equipment marketed within the U.S. or its possessions, shall compile a description of the measurement facilities employed.
 - (1) If the measured equipment is subject to the verification procedure, the description of the measurement facilities shall be retained by the party responsible for verification of the equipment.
 - (i) *If the equipment is verified through measurements performed by an independent laboratory, it is acceptable for the party responsible for verification of the equipment to rely upon the description of the measurement facilities retained by or placed on file with the Commission by that laboratory. In this situation, the party responsible for the verification of the equipment is not required to retain a duplicate copy of the description of the measurement facilities.*
 - (ii) If the equipment is verified based on measurements performed at the installation site of the equipment, no specific site calibration data is required. It is acceptable to retain the description of the measurement facilities at the site at which the measurements were performed.
 - (2) If the equipment is to be authorized by the Commission under the certification procedure, the description of the measurement facilities shall be filed with the Commission's Laboratory in Columbia, Maryland. The data describing the measurement facilities need only be filed once but must be updated as changes are made to the measurement facilities or as otherwise described in this section. At least every three years, the organization responsible for filing the data with the Commission shall certify that the data on file is current.



Certification & User's Manual Information

Label and User's Manual Information

The following is extracted from Title 47 of the Code of Federal Regulations, Part 15, Subpart A — General:

§ 15.19 Labeling requirements.

(a) *In addition to the requirements in Part 2 of this chapter, a device subject to certification or verification shall be labeled as follows:*

- (1) Receivers associated with the operation of a licensed radio service, e.g., FM broadcast under Part 73 of this chapter, land mobile operation under Part 90, etc., shall bear the following statement in a conspicuous location on the device:

This device complies with Part 15 of the FCC Rules. Operation is subject to the condition that this device does not cause harmful interference.

- (2) A stand-alone cable input selector switch, shall bear the following statement in a conspicuous location on the device:

This device is verified to comply with Part 15 of the FCC Rules for use with cable television service.

- (3) All other devices shall bear the following statement in a conspicuous location on the device:

This device complies with Part 15 of the FCC Rules. Operation is subject to the following two conditions: (1) This device may not cause harmful interference, and (2) this device must accept any interference received, including interference that may cause undesired operation.

- (4) Where a device is constructed in two or more sections connected by wires and marketed together, the statement specified under paragraph (a) of this section is required to be affixed only to the main control unit.

- (5) When the device is so small or for such use that it is not practicable to place the statement specified under paragraph (a) of this section on it, the information required by this paragraph shall be placed in a prominent location in the instruction manual or pamphlet supplied to the user or, alternatively, shall be placed on the container in which the device is marketed. However, the FCC identifier or the unique identifier, as appropriate, must be displayed on the device.

§ 15.21 Information to user.

The users manual or instruction manual for an intentional or unintentional radiator shall caution the user that changes or modifications not expressly approved by the party responsible for compliance could void the user's authority to operate the equipment.



Verification & User's Manual Information

The following is extracted from Title 47 of the Code of Federal Regulations, Part 15, Subpart B — Unintentional Radiators:

§ 15.105 Information to the user.

- (a) For a Class B digital device or peripheral, the instructions furnished the user shall include the following or similar statement, placed in a prominent location in the text of the manual:

Note: This equipment has been tested and found to comply with the limits for a Class B digital device, pursuant to Part 15 of the FCC Rules. These limits are designed to provide reasonable protection against harmful interference when the equipment is operated in a residential environment. This equipment generates, uses, and can radiate radio frequency energy and, if not installed and used in accordance with the instruction manual, may cause harmful interference to radio communications. However, there is no guarantee that interference will not occur in a particular installation. If this equipment does cause harmful interference to radio or television reception, which can be determined by turning the equipment off and on, the user is encouraged to try to correct the interference by one or more of the following measures:

- Reorient or relocate the receiving antenna.
- Increase the separation between the equipment and receiver.
- Connect the equipment into an outlet on a circuit different from that to which the receiver is connected.
- Consult the dealer or an experienced radio/TV technician for help.



ICES-003 Procedural & Labeling Requirements

From the Industry Canada Electromagnetic Compatibility Advisory Bulletin entitled, "Implementation and Interpretation of the Interference-Causing Equipment Standard for Digital Apparatus, ICES-003" (EMCAB-3, Issue 2, July 1995):

"At present, CISPR 22: 2002 and ICES technical requirements are essentially equivalent. Therefore, if you have CISPR 22: 2002 approval by meeting CISPR Publication 22, the only additional requirements are: to attach a note to the report of the test results for compliance, indicating that these results are deemed satisfactory evidence of compliance with ICES-003 of the Canadian Interference-Causing Equipment Regulations; to maintain these records on file for the requisite five year period; and to provide the device with a notice of compliance in accordance with ICES-003."

Procedural Requirements:

According to Industry Canada's Interference Causing Equipment Standard for Digital Apparatus ICES-003 Issue 4, February 2004:

- Section 6.1: A record of the measurements and results, showing the date that the measurements were completed, shall be retained by the manufacturer or importer for a period of at least five years from the date shown in the record and made available for examination on the request of the Minister.
- Section 6.2: A written notice indicating compliance must accompany each unit of digital apparatus to the end user. The notice shall be in the form of a label that is affixed to the apparatus. Where because of insufficient space or other constraints it is not feasible to affix a label to the apparatus, the notice may be in the form of a statement in the user's manual.

Labeling Requirements:

The suggested text for the notice, in English and in French, is provided below, from the Annex of ICES-003:

This Class [²] digital apparatus complies with Canadian ICES-003.

Cet appareil numérique de la classe [¹] est conforme à la norme NMB-003 du Canada.

² Insert either A or B but not both as appropriate for the equipment requirements.



End of Report