

## TEST REPORT

**Report Number: 18081638HKG-001**

Application for Original Grant of 47 CFR Part 15 Certification

Single New Application of RSS-247 Issue 2 Equipment

This report contains the data of Bluetooth 4.0 BLE portion only.

**FCC ID: Q20-NADM10**

**IC: 152B-NADM10**

**Prepared and Checked by:**

**Approved by:**

Signed On File  
Wong Cheuk Ho, Herbert  
Lead Engineer

---

Wong Kwok Yeung, Kenneth  
Senior Lead Engineer  
Date: February 14, 2019

---

Intertek's standard Terms and Conditions can be obtained at our website <http://www.intertek.com/terms/>.

The test report only allows to be revised within the retention period unless further standard or the requirement was noticed.

This report is for the exclusive use of Intertek's Client and is provided pursuant to the agreement between Intertek and its Client. Intertek's responsibility and liability are limited to the terms and conditions of the agreement. Intertek assumes no liability to any party, other than to the Client in accordance with the agreement, for any loss, expense or damage occasioned by the use of this report. Only the Client is authorized to permit copying or distribution of this report and then only in its entirety. Any use of the Intertek name or one of its marks for the sale or advertisement of the tested material, product or service must first be approved in writing by Intertek. The observations and test results in this report are relevant only to the sample tested. This report by itself does not imply that the material, product, or service is or has ever been under an Intertek certification program.

© 2017 Intertek

## TEST REPORT

### GENERAL INFORMATION

<b>Applicant Name:</b>	Lenbrook Industries Ltd
<b>Applicant Address:</b>	633 Granite Court Pickering ON L1W 3K1 Canada
<b>FCC Specification Standard:</b>	FCC Part 15, October 1, 2017 Edition
<b>FCC ID:</b>	Q2O-NADM10
<b>FCC Model(s):</b>	M10
<b>IC Specification Standard:</b>	RSS-247 Issue 2, February 2017 RSS-Gen Issue 5, April 2018
<b>IC:</b>	152B-NADM10
<b>PMN:</b>	BluOS STREAMING AMPLIFIER
<b>HVIN:</b>	M10
<b>Type of EUT:</b>	Spread Spectrum Transmitter
<b>Description of EUT:</b>	BluOS STREAMING AMPLIFIER
<b>Serial Number:</b>	N/A
<b>Sample Receipt Date:</b>	November 05, 2018
<b>Date of Test:</b>	November 05, 2018 to February 14, 2019
<b>Report Date:</b>	February 14, 2019
<b>Environmental Conditions:</b>	Temperature: +10 to 40°C Humidity: 10 to 90%

**TEST REPORT**

**TABLE OF CONTENTS**

**1.0 TEST RESULTS SUMMARY & STATEMENT OF COMPLIANCE ..... 4**

    1.1 Summary of Test Results.....4

    1.2 Statement of Compliance.....4

**2.0 GENERAL DESCRIPTION..... 5**

    2.1 Product Description .....5

    2.2 Test Methodology .....7

    2.3 Test Facility .....7

    2.4 Related Submittal(s) Grants .....7

**3.0 SYSTEM TEST CONFIGURATION..... 8**

    3.1 Justification .....8

    3.2 EUT Exercising Software.....9

    3.3 Details of EUT and Description of Accessories.....10

    3.4 Measurement Uncertainty.....10

**4.0 TEST RESULTS ..... 11**

    4.1 Maximum Conducted Output Power at Antenna Terminals .....11

    4.2 Minimum 6dB RF Bandwidth.....12

    4.3 Maximum Power Spectral Density .....15

    4.4 Out of Band Conducted Emissions .....18

    4.5 Field Strength Calculation.....23

    4.6 Transmitter Radiated Emissions in Restricted Bands and Spurious Emissions.....24

        4.6.1 Radiated Emission Configuration Photograph .....24

        4.6.2 Radiated Emission Data .....24

        4.6.3 Radiated Emission Test Setup.....29

        4.6.4 Transmitter Duty Cycle Calculation .....30

    4.7 AC Power Line Conducted Emission .....31

    4.8 Occupied Bandwidth .....36

**5.0 EQUIPMENT LIST ..... 37**

## TEST REPORT

### 1.0 TEST RESULTS SUMMARY & STATEMENT OF COMPLIANCE

#### 1.1 Summary of Test Results

Test Items	FCC Part 15 Section	RSS-247/ RSS-Gen# Section	Results	Details See Section
Antenna Requirement	15.203	7.1.2#	Pass	2.1
Max. Conducted Output Power (Peak)	15.247(b)(3)&(4)	5.4(4)	Pass	4.1
Min. 6dB RF Bandwidth	15.247(a)(2)	5.2(1)	Pass	4.2
Max. Power Density (average)	15.247(e)	5.2(2)	Pass	4.3
Out of Band Antenna Conducted Emission	15.247(d)	5.5	Pass	4.4
Radiated Emission in Restricted Bands and Spurious Emissions	15.247(d), 15.209 & 15.109	5.5	Pass	4.6
AC Power Line Conducted Emission	15.207 & 15.107	7.2.4#	N/A	4.7

Note: Pursuant to FCC Part 15 Section 15.215(c), the 20dB bandwidth of the emission was contained within the frequency band designated (mentioned as above) which the EUT operated. The effects, if any, from frequency sweeping, frequency hopping, other modulation techniques and frequency stability over expected variations in temperature and supply voltage were considered.

#### 1.2 Statement of Compliance

The equipment under test is found to be complying with the following standard:

FCC Part 15, October 1, 2017 Edition  
RSS-247 Issue 2, February 2017  
RSS-Gen Issue 5, April 2018

## TEST REPORT

### 2.0 GENERAL DESCRIPTION

#### 2.1 Product Description

The Equipment-Under-Test (EUT) M10 is a BluOS STREAMING AMPLIFIER. The EUT contains both WLAN (WiFi) and Bluetooth modules. The Bluetooth module has Bluetooth 4.0 BLE and Bluetooth 3.0 features. The EUT can accept analog audio signal, digital audio signal and wireless audio signal via Bluetooth devices. The EUT has internal power amplifiers and loudspeaker. The EUT is powered by 100-120VAC, 200-240VAC. The NFC is a 13.56MHz passive tag only.

##### For the WLAN (WiFi) module:

###### For 2.400-2.4835GHz:

The Equipment Under Test (EUT) operates at frequency range of 2412MHz to 2462MHz with 11 channels. For 802.11b mode, it operates at frequency range of 2412.000MHz to 2462.000MHz with 11 channels. It transmits via Direct-sequence spread spectrum (DSSS) modulation. Maximum bit rate can be up to 11Mbps.

For 802.11g mode, it operates at frequency range of 2412.000MHz to 2462.000MHz with 11 channels. It transmits via Orthogonal Frequency Division Multiplexing (OFDM) modulation. Maximum bit rate can be up to 54Mbps.

For 802.11n (with 20MHz bandwidth) mode, it operates at frequency range of 2412.000MHz to 2462.000MHz with 11 channels. It transmits via Orthogonal Frequency Division Multiplexing (OFDM) modulation. Maximum bit rate can support up to 65Mbps.

For 802.11n (with 40MHz bandwidth) mode, it operates at frequency range of 2422.000MHz to 2452.000MHz with 7 channels. It transmits via Orthogonal Frequency Division Multiplexing (OFDM) modulation. Maximum bit rate can support up to 65Mbps.

###### For 5.15-5.25GHz:

The Equipment Under Test (EUT) operates at frequency range of 5180MHz to 5240MHz with 4 channels.

For 802.11a mode, it operates at frequency range of 5180.00MHz to 5250.000MHz with 4 channels. It transmits via Orthogonal Frequency Division Multiplexing (OFDM) modulation. Maximum bit rate can be up to 54Mbps.

For 802.11n (with 20MHz bandwidth) mode, it operates at frequency range of 5180.00MHz to 5250.000MHz with 4 channels. It transmits via Orthogonal Frequency Division Multiplexing (OFDM) modulation. Maximum bit rate can support up to 65.0Mbps.

For 802.11n (with 40MHz bandwidth) mode, it operates at frequency range of 5190.00MHz to 5230.000MHz with 2 channels. It transmits via Orthogonal Frequency Division Multiplexing (OFDM) modulation. Maximum bit rate can support up to 135.0Mbps.

For 802.11ac (with 20MHz bandwidth) mode, it operates at frequency range of 5180.00MHz to 5250.000MHz with 4 channels. It transmits via Orthogonal Frequency Division Multiplexing (OFDM) modulation. Maximum bit rate can support up to 86.7Mbps.

For 802.11ac (with 40MHz bandwidth) mode, it operates at frequency range of 5190.00MHz to 5230.000MHz with 2 channels. It transmits via Orthogonal Frequency Division Multiplexing (OFDM) modulation. Maximum bit rate can support up to 180Mbps.

For 802.11ac (with 80MHz bandwidth) mode, it operates at frequency 5210MHz. It transmits via Orthogonal Frequency Division Multiplexing (OFDM) modulation. Maximum bit rate can support up to 390Mbps.

## TEST REPORT

### For 5.725-5.850GHz:

The Equipment Under Test (EUT) operates at frequency range of 5745MHz to 5825MHz with 5 channels. For 802.11a mode, it operates at frequency range of 5745.00MHz to 5825.000MHz with 5 channels. It transmits via Orthogonal Frequency Division Multiplexing (OFDM) modulation. Maximum bit rate can be up to 54Mbps.

For 802.11n (with 20MHz bandwidth) mode, it operates at frequency range of 5745MHz to 5825MHz with 5 channels. It transmits via Orthogonal Frequency Division Multiplexing (OFDM) modulation. Maximum bit rate can support up to 216.6Mbps.

For 802.11n (with 40MHz bandwidth) mode, it operates at frequency range of 5755.00MHz to 5795.000MHz with 2 channels. It transmits via Orthogonal Frequency Division Multiplexing (OFDM) modulation. Maximum bit rate can support up to 450Mbps.

For 802.11ac (with 20MHz bandwidth) mode, it operates at frequency range of 5745MHz to 5825MHz with 5 channels. It transmits via Orthogonal Frequency Division Multiplexing (OFDM) modulation. Maximum bit rate can support up to 260Mbps.

For 802.11ac (with 40MHz bandwidth) mode, it operates at frequency range of 5755.00MHz to 5795.000MHz with 2 channels. It transmits via Orthogonal Frequency Division Multiplexing (OFDM) modulation. Maximum bit rate can support up to 600Mbps.

For 802.11ac (with 80MHz bandwidth) mode, it operates at frequency 5775MHz. It transmits via Orthogonal Frequency Division Multiplexing (OFDM) modulation. Maximum bit rate can support up to 1300Mbps.

### For the Bluetooth module:

For Bluetooth 4.0 BLE mode, it occupies a frequency range from 2402MHz to 2480MHz (40 channels with channel spacing of 2MHz). It transmits via GFSK modulation.

For Bluetooth 3.0 mode, it occupies a frequency range from 2402MHz to 2480MHz (79 channels with channel spacing of 1MHz). It transmits via GFSK modulation.

The antenna(s) used in the EUT is internal, integral.

The circuit description is saved with filename: descri.pdf.

This report contains the data of Bluetooth 4.0 BLE portion only.

## TEST REPORT

### 2.2 Test Methodology

Both AC power line-conducted and radiated emission measurements were performed according to the procedures in ANSI C63.10 (2013). Preliminary radiated scans and all radiated measurements were performed in radiated emission test sites. All Radiated tests were performed at an antenna to EUT distance of 3 meters, unless stated otherwise in the "**Justification Section**" of this Application. Antenna port conducted measurements were performed according to ANSI C63.10 (2013) and KDB Publication No.558074 D01 v05r01 (11-February-2019) All other measurements were made in accordance with the procedures in 47 CFR Part 2 and RSS-Gen Issue 5 (2018).

### 2.3 Test Facility

The radiated emission test site and antenna port conducted measurement facility used to collect the radiated data and conductive data are at Workshop No. 3, G/F., World-Wide Industrial Centre, 43-47 Shan Mei Street, Fo Tan, Sha Tin, N.T., Hong Kong. This test facility and site measurement data have been fully placed on file with the FCC and Industry Canada No.: 2042V-1.

### 2.4 Related Submittal(s) Grants

This is a single application for certification of a transceiver (Bluetooth portion)

## TEST REPORT

### 3.0 SYSTEM TEST CONFIGURATION

#### 3.1 Justification

For radiated emissions testing, the equipment under test (EUT) was setup to transmit / receive continuously to simplify the measurement methodology. Care was taken to ensure proper power supply voltages during testing. During testing, all cables (if any) were manipulated to produce worst case emissions.

The EUT was powered by 120VAC.

For the measurements, the EUT was attached to a plastic stand if necessary and placed on the wooden turntable. If the base unit attached to peripherals, they were connected and operational (as typical as possible).

The signal was maximized through rotation and placement in the three orthogonal axes. The antenna height and polarization were varied during the search for maximum signal level. The antenna height was varied from 1 to 4 meters. Radiated emissions were taken at three meters unless the signal level was too low for measurement at that distance. If necessary, a pre-amplifier was used and/or the test was conducted at a closer distance.

For any intentional radiator powered by AC power line, measurements of the radiated signal level of the fundamental frequency component of the emission was performed with the supply voltage varied between 85% and 115% of the nominal rated supply voltage.

Radiated emission measurement for transmitter were performed from the lowest radio frequency signal generated in the device which is greater than 9 kHz to the tenth harmonic of the highest fundamental frequency or to 40 GHz, whichever is lower.

Emission that are directly caused by digital circuits in the transmit path and transmitter portion were measured, and the limit are according to FCC Part 15 Section 15.209 / RSS-247 2.5. Digital circuitries used to control additional functions other than the operation of the transmitter are subject to FCC Part 15 Section 15.109 / RSS-247 Section 5.5 Limits.



## TEST REPORT

### 3.1 Justification – Cont'd

Detector function for radiated emissions was in peak mode. Average readings, when required, were taken by measuring the duty cycle of the equipment under test and subtracting the corresponding amount in dB from the measured peak readings. A detailed description for the calculation of the average factor can be found in section 4.8.3.

Determination of pulse desensitization was made according to *Hewlett Packard Application Note 150-2, Spectrum Analysis... Pulsed RF*. The effective period (Teff) was referred to Exhibit 4.8.3. With the resolution bandwidth 1MHz and spectrum analyzer IF bandwidth 3dB, the pulse desensitization factor was 0dB.

For AC line conducted emission test, the EUT along with its peripherals were placed on a 1.0m(W)x1.5m(L) and 0.8m in height wooden table and the EUT was adjusted to maintain a 0.4 meter space from a vertical reference plane. The EUT was connected to power mains through a line impedance stabilization network (LISN), which provided 50ohm coupling impedance for measuring instrument. The LISN housing, measuring instrument case, reference ground plane, and vertical ground plane were bounded together. The excess power cable between the EUT and the LISN was bundled.

All connecting cables of EUT and peripherals were manipulated to find the maximum emission.

Different data rates have been tested. Worst case is reported only.

All relevant operation modes have been tested, and the worst case data is included in this report.

All data rates were tested under normal mode of Bluetooth 4.0 BLE. Only the worst-case data is shown in the report for GFSK.

For simultaneous transmission, both WiFi and Bluetooth portions are also switched on when taking radiated emission for determining worst-case spurious emission.

### 3.2 EUT Exercising Software

The EUT exercise program (if any) used during radiated and conducted testing was designed to exercise the various system components in a manner similar to a typical use.

## TEST REPORT

### 3.3 Details of EUT and Description of Accessories

#### Details of EUT:

- (1) The EUT is powered by 120VAC

#### Description of Accessories:

1. IR-in cable of 2 meter long with termination
2. 12V-trigger cable of 2 meter long with termination
3. HDMI cable of 2 meter long with termination
4. 4GB USB flash drive
5. Pair of loudspeaker with cable of 0.5 meter long
6. LAN cable of 2 meter long with termination
7. Power Cable of 2 meter long
8. 5 X Analog coaxial cable of 2 meter long with termination  
(Provided by Intertek)

### 3.4 Measurement Uncertainty

When determining of the test conclusion, the Measurement Uncertainty of test at a level of confidence of 95% has been considered. The values of the Measurement uncertainty for radiated emission test and RF conducted measurement test are  $\pm 5.3\text{dB}$  and  $\pm 0.99\text{dB}$  respectively. The value of the Measurement uncertainty for conducted emission test is  $\pm 4.2\text{dB}$ .

Uncertainty and Compliance - Unless the standard specifically states that measured values are to be extended by the measurement uncertainty in determining compliance, all compliance determinations are based on the actual measured value.

**TEST REPORT**

**4.0 TEST RESULTS**

4.1 Maximum Conducted (peak) Output Power at Antenna Terminals

RF Conduct Measurement Test Setup

The figure below shows the test setup, which is utilized to make these measurements.

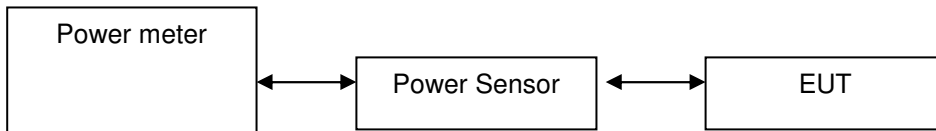

The antenna port of the EUT was connected to the input of a spectrum analyzer.

- The antenna power of the EUT was connected to the input of a power meter. Power was read directly and cable loss correction was added to the reading to the obtain power at the EUT antenna terminals. The measurement procedure 9.1.2 was used.
- The EUT should be configured to transmit continuously (at a minimum duty cycle of 98%) at full power over the measurement duration. The measurement procedure AVG1 was used.

Antenna Gain = 2.0 dBi

Frequency (MHz)	Output in dBm	Output in mWatt
Low Channel: 2402	3.52	2.25
Middle Channel: 2442	4.04	2.54
High Channel: 2480	4.22	2.64

Cable loss : 0.5 dB External Attenuation : 0 dB

Cable loss, external attenuation:  included in OFFSET function  
 added to SA raw reading

Max. conducted (peak) output level = 4.22 dBm

Limits:

- 1W (30dBm) for antennas with gains of 6dBi or less
- \_\_\_W (\_\_\_dBm) for antennas with gains more than 6dBi

## TEST REPORT

### 4.2 Minimum 6dB RF Bandwidth

The antenna port of the EUT was connected to the input of a spectrum analyzer. The EBW measurement procedure was used. A PEAK output reading was taken, a DISPLAY line was drawn 6dB lower than PEAK level. The 6dB bandwidth was determined from where the channel output spectrum intersected the display line.

	<b>Frequency (MHz)</b>	<b>6dB Bandwidth (MHz)</b>
Low Channel:	2402	0.726
Middle Channel:	2442	0.738
High Channel:	2480	0.726

#### Limits

6 dB bandwidth shall be at least 500kHz

The plots of 6dB RF bandwidth are saved as below.

**TEST REPORT**

**PLOTS OF 6dB RF BANDWIDTH**

Lowest Channel

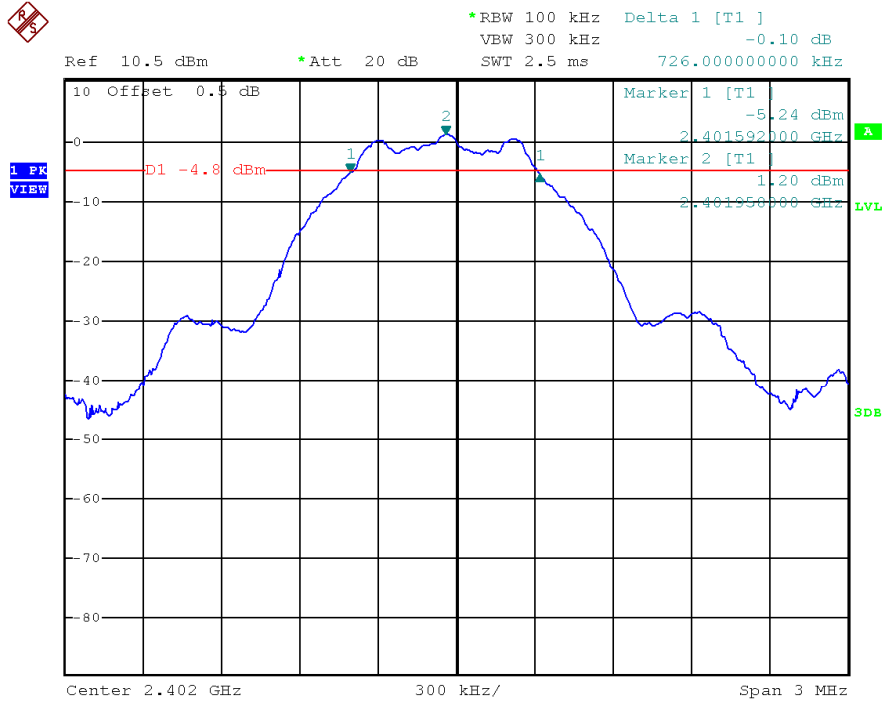

Middle Channel

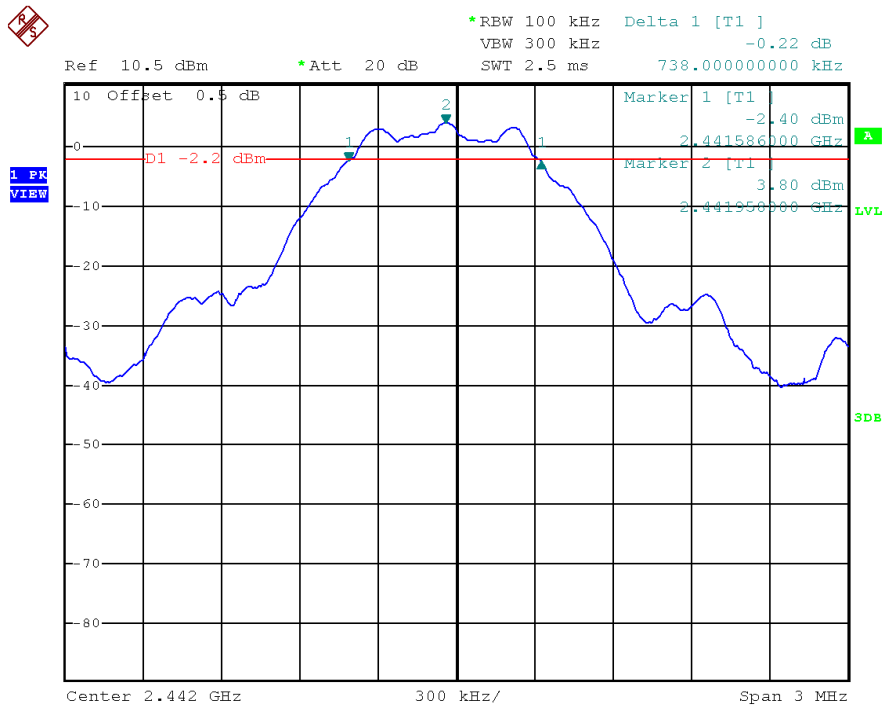

**TEST REPORT**

**PLOTS OF 6dB RF BANDWIDTH**

Highest Channel

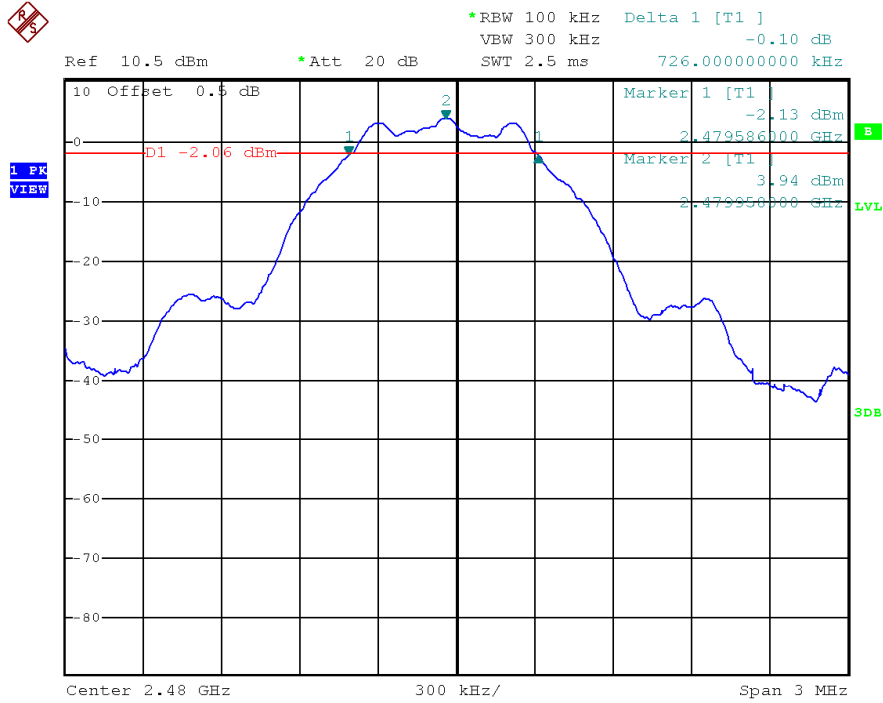

## TEST REPORT

### 4.3 Maximum Power Spectral Density

Antenna output of the EUT was coupled directly to spectrum analyzer. The measurement procedure 10.2 PKPSD was used. If an external attenuator and/or cable was used, these losses are compensated for using the OFFSET function of the analyser.

Frequency (MHz)		PSD in 100kHz (dBm)
Low Channel:	2402	1.2
Middle Channel:	2442	3.8
High Channel:	2480	4.0

Cable Loss: 0.5 dB

Limit:  
8dBm

The plots of power spectral density are as below.

**TEST REPORT**

**PLOTS OF POWER SPECTRAL DENSITY**

Lowest channel

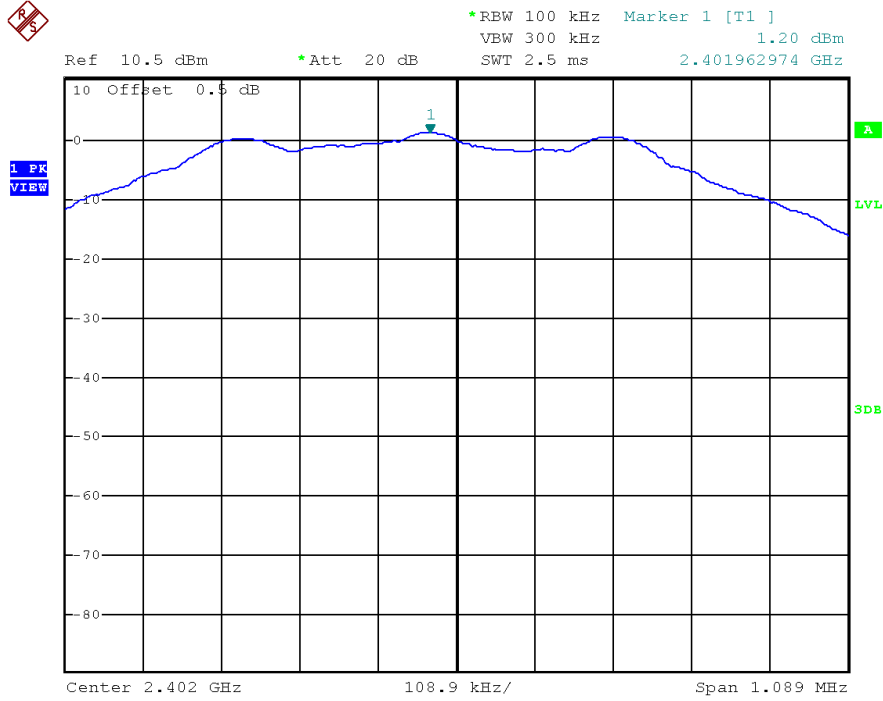

Middle channel

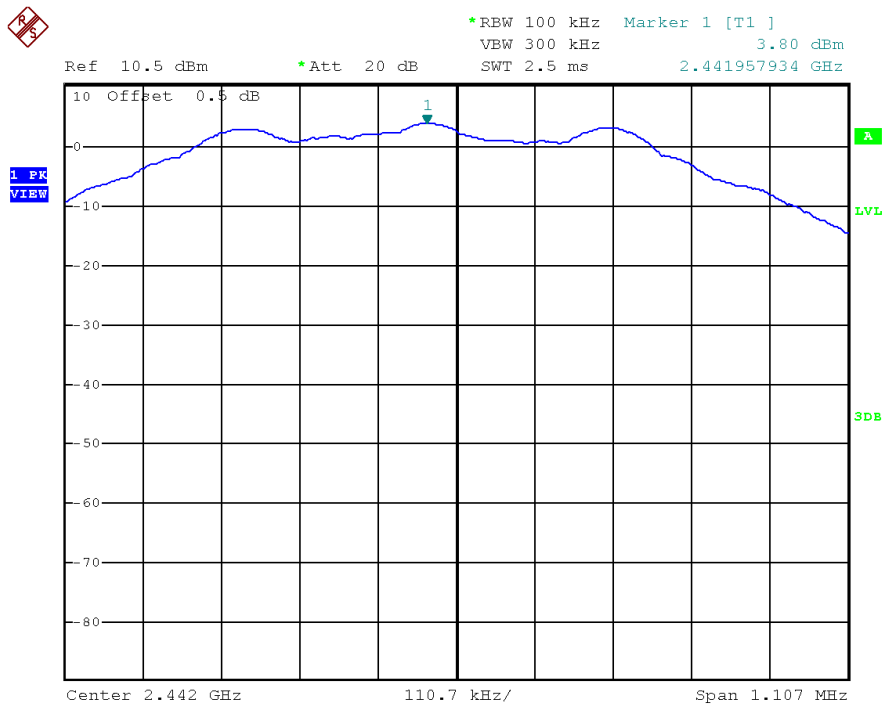



## TEST REPORT

### PLOTS OF POWER SPECTRAL DENSITY

Highest channel

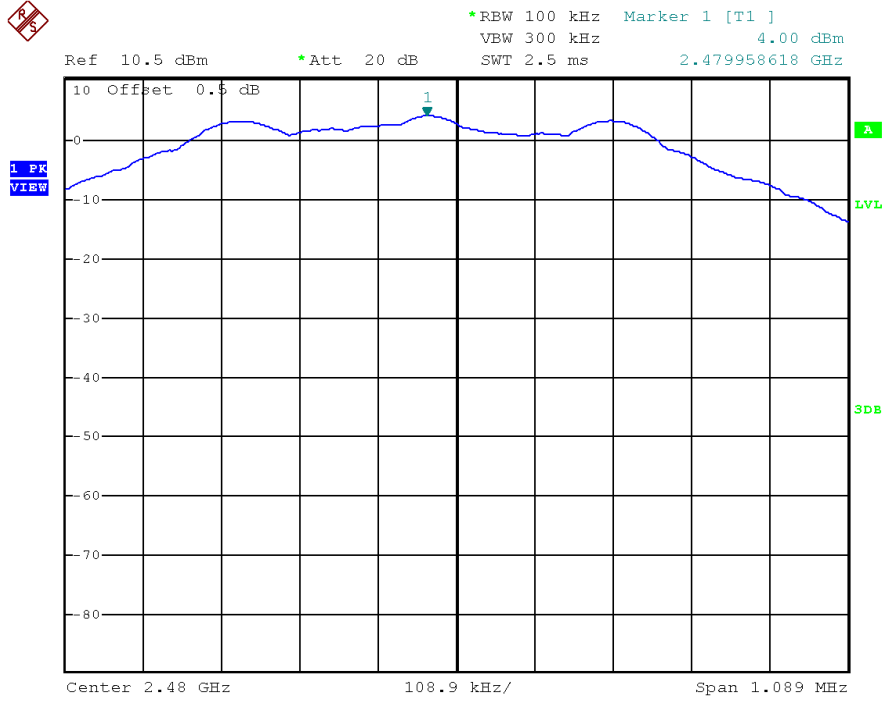

## TEST REPORT

### 4.4 Out of Band Conducted Emissions

For Bluetooth 4.0 BLE, the maximum conducted (peak) output power was used to demonstrate compliance as described in 9.1. Then the display line (in red) shown in the following plots denotes the limit at 20dB below maximum measured in-band peak PSD level in 100 KHz bandwidth for Bluetooth 4.0 BLE.

The measurement procedures under sections 11 of KDB558074 D01 v05r01 (11- February -2019) were used.

Furthermore, delta measurement technique for measuring bandedge emissions was incorporated in the test of the edge at 2483.5MHz.

#### Limits:

All spurious emission and up to the tenth harmonic was measured and they were found to be at least for Bluetooth 4.0 BLE below the maximum measured in-band peak PSD level.

**TEST REPORT**

**PLOTS OF OUT OF BAND CONDUCTED EMISSIONS**

Lowest Channel, Bandedge

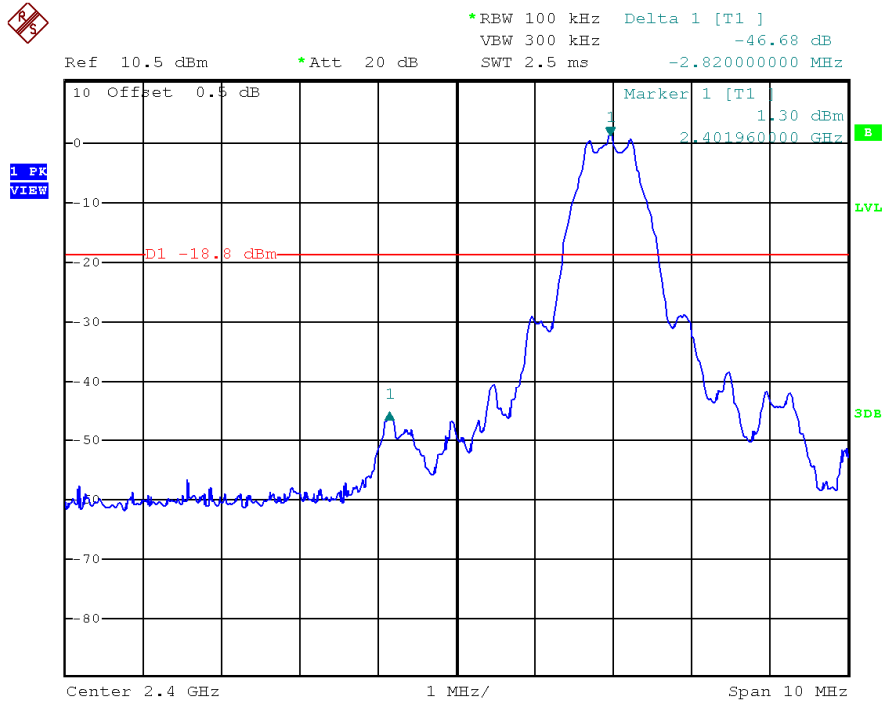

Highest Channel, Bandedge

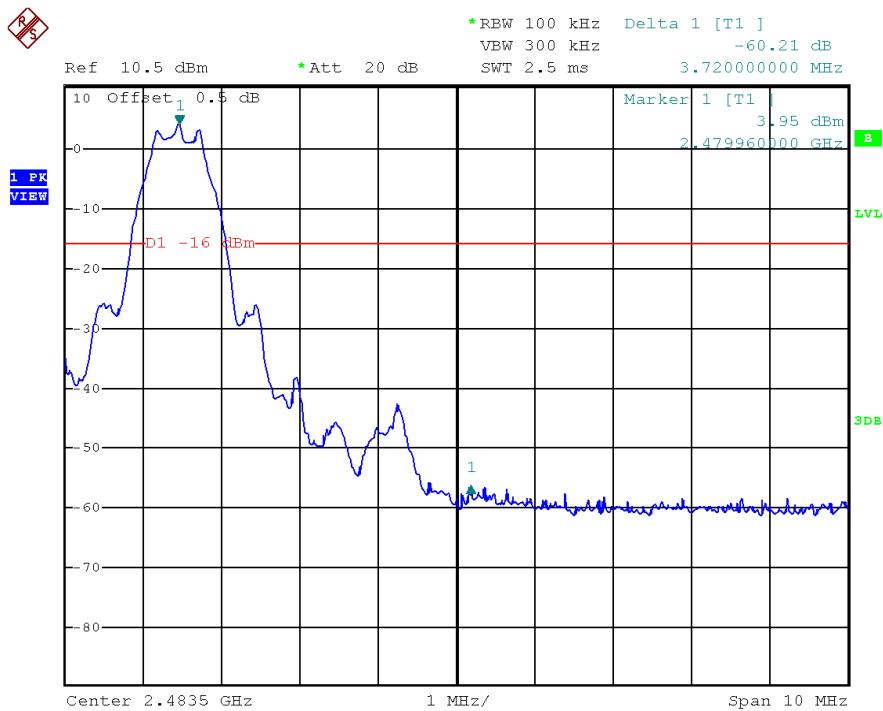

**TEST REPORT**

**PLOTS OF OUT OF BAND CONDUCTED EMISSIONS**

Lowest Channel, Plot A

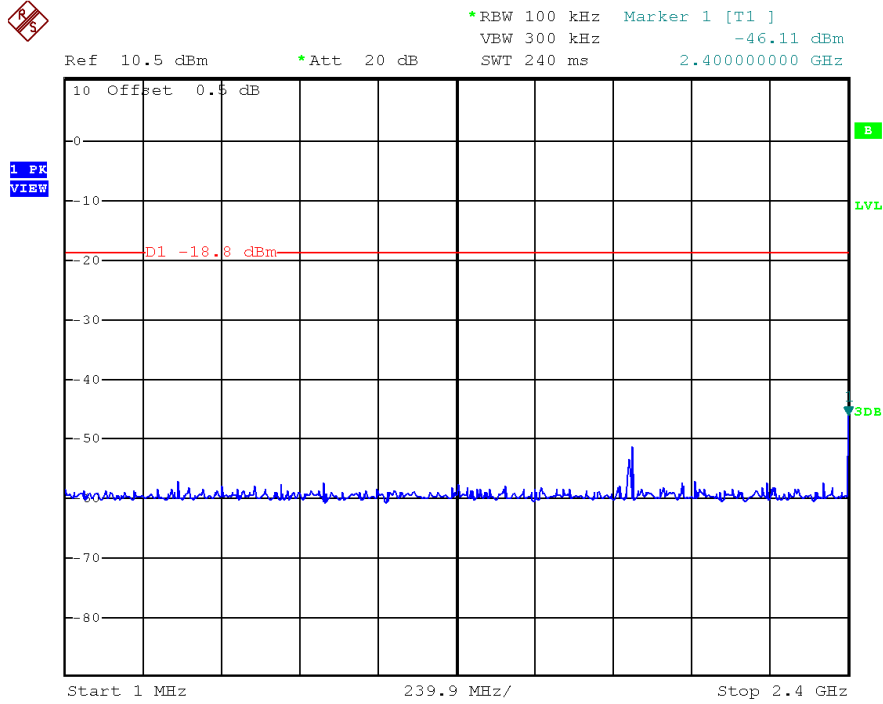

Lowest Channel, Plot B

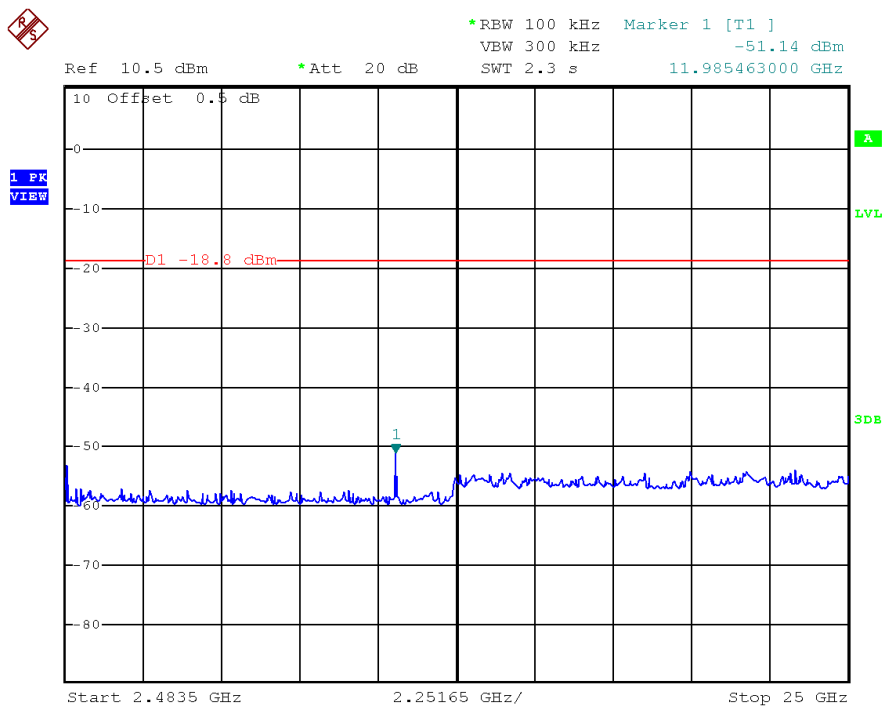

**TEST REPORT**

**PLOTS OF OUT OF BAND CONDUCTED EMISSIONS**

Middle Channel, Plot A

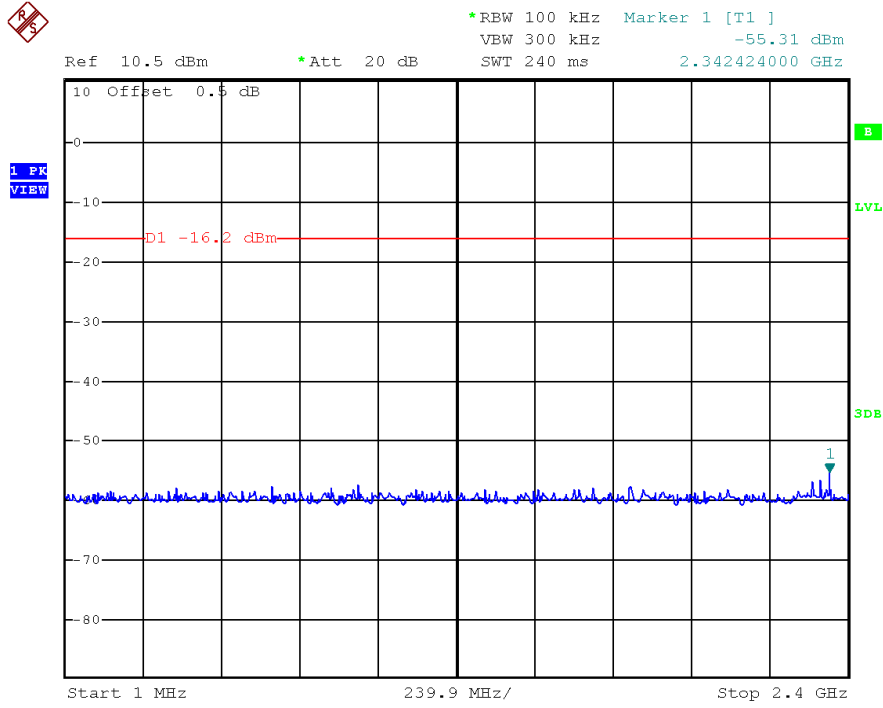

Middle Channel, Plot B

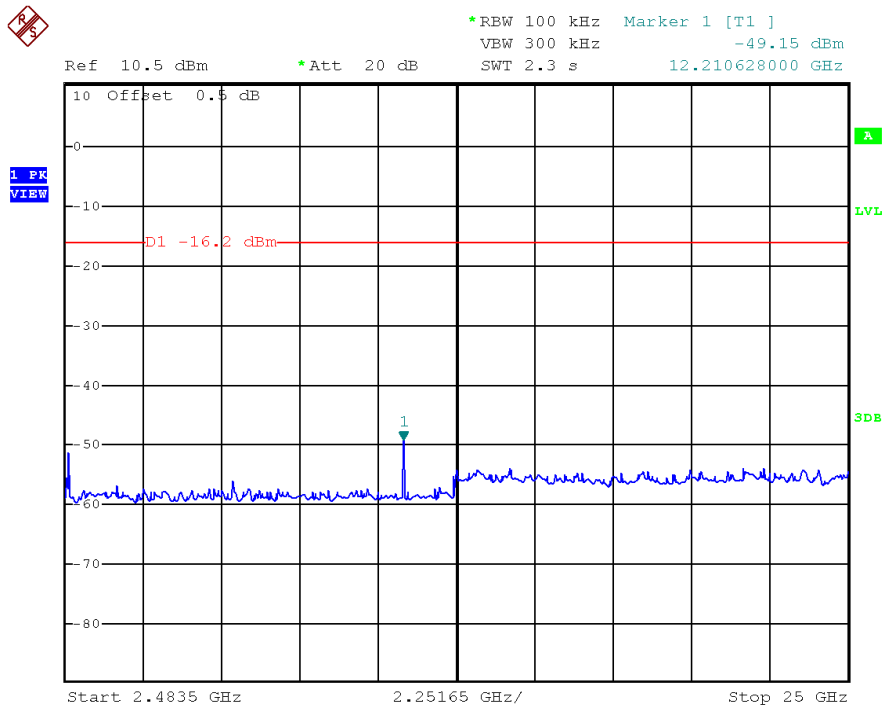

**TEST REPORT**

**PLOTS OF OUT OF BAND CONDUCTED EMISSIONS**

Highest Channel, Plot A

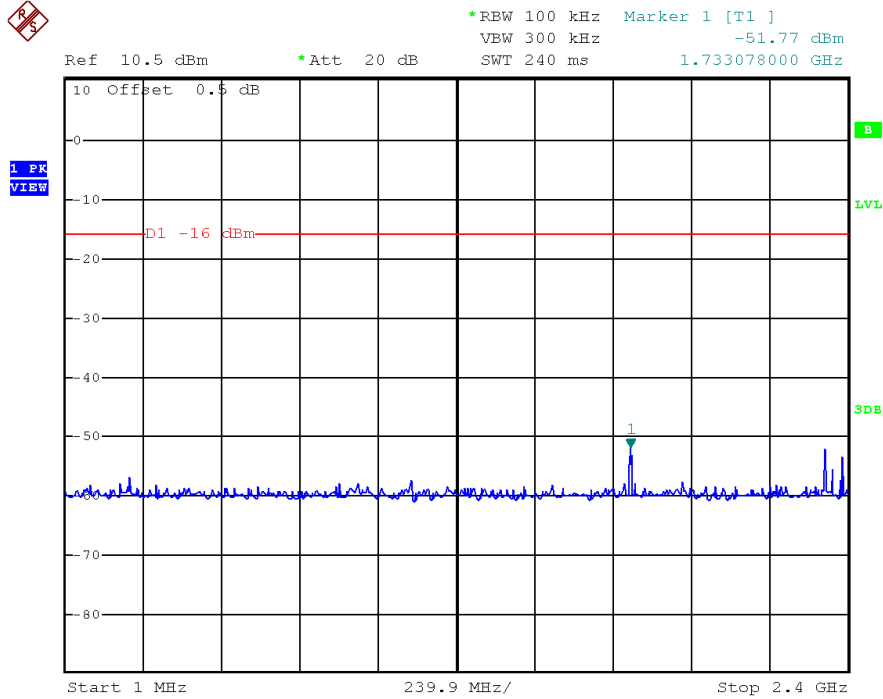

Highest Channel, Plot B

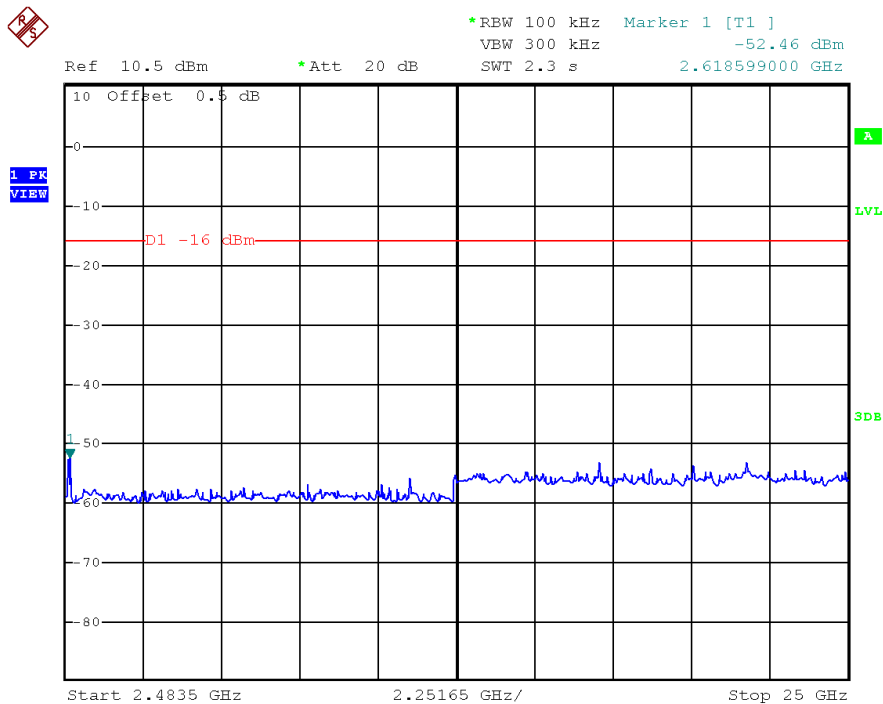

## TEST REPORT

### 4.5 Field Strength Calculation

The field strength is calculated by adding the reading on the Spectrum Analyzer to the factors associated with preamplifiers (if any), antennas, cables, pulse desensitization and average factors (when specified limit is in average and measurements are made with peak detectors). A sample calculation is included below.

$$FS = RA + AF + CF - AG + PD + AV$$

Where FS = Field Strength in dB $\mu$ V/m

RA = Receiver Amplitude (including preamplifier) in dB $\mu$ V

CF = Cable Attenuation Factor in dB

AF = Antenna Factor in dB

AG = Amplifier Gain in dB

PD = Pulse Desensitization in dB

AV = Average Factor in -dB

In the radiated emission table which follows, the reading shown on the data table may reflect the preamplifier gain. An example of the calculations, where the reading does not reflect the preamplifier gain, follows:

$$FS = RA + AF + CF - AG + PD + AV$$

#### Example

Assume a receiver reading of 62.0 dB $\mu$ V is obtained. The antenna factor of 7.4 dB and cable factor of 1.6 dB is added. The amplifier gain of 29.0 dB is subtracted. The pulse desensitization factor of the spectrum analyzer is 0.0 dB, and the resultant average factor is -10.0 dB. The net field strength for comparison to the appropriate emission limit is 32.0 dB $\mu$ V/m. This value in dB $\mu$ V/m is converted to its corresponding level in  $\mu$ V/m.

$$RA = 62.0 \text{ dB}\mu\text{V}$$

$$AF = 7.4 \text{ dB}$$

$$CF = 1.6 \text{ dB}$$

$$AG = 29.0 \text{ dB}$$

$$PD = 0.0 \text{ dB}$$

$$AV = -10 \text{ dB}$$

$$FS = 62.0 + 7.4 + 1.6 - 29.0 + 0.0 + (-10.0) = 32.0 \text{ dB}\mu\text{V/m}$$

$$\text{Level in } \mu\text{V/m} = \text{Common Antilogarithm } [(32.0 \text{ dB}\mu\text{V/m})/20] = 39.8 \mu\text{V/m}$$

## TEST REPORT

### 4.6 Transmitter Radiated Emissions in Restricted Bands and Spurious Emissions

Data is included of the worst case configuration (the configuration which resulted in the highest emission levels). A sample calculation, configuration photographs and data tables of the emissions are included.

The data on the following pages list the significant emission frequencies, the limit and the margin of compliance.

#### 4.6.1 Radiated Emission Configuration Photograph

Worst Case Restricted Band Radiated Emission  
at

56.410 MHz

The worst case radiated emission configuration photographs are saved with filename: config photos.pdf

#### 4.6.2 Radiated Emission Data

The data in tables 1-4 list the significant emission frequencies, the limit and the margin of compliance.

Judgement -

Passed by 0.2 dB margin



**TEST REPORT**

**RADIATED EMISSION DATA**

Mode: TX-Channel 00

Table 1

Polari- zation	Frequency (MHz)	Reading	Correction Factor	Net at 3m - Peak (dBµV/m)	Average Factor (dB)	Calculated at 3m (dBµV/m)	Average Limit at 3m (dBµV/m)	Margin (dB)
<b><i>H</i></b>	<b><i>2390.000</i></b>	<b><i>55.9</i></b>	<b><i>-3.5</i></b>	<b><i>52.4</i></b>	<b><i>0</i></b>	<b><i>52.4</i></b>	<b><i>54.0</i></b>	<b><i>-1.6</i></b>
<b><i>H</i></b>	<b><i>4804.000</i></b>	<b><i>42.1</i></b>	<b><i>6.5</i></b>	<b><i>48.6</i></b>	<b><i>0</i></b>	<b><i>48.6</i></b>	<b><i>54.0</i></b>	<b><i>-5.4</i></b>
<b><i>H</i></b>	<b><i>12010.000</i></b>	<b><i>31.7</i></b>	<b><i>20.1</i></b>	<b><i>51.8</i></b>	<b><i>0</i></b>	<b><i>51.8</i></b>	<b><i>54.0</i></b>	<b><i>-2.2</i></b>

Polari- zation	Frequency (MHz)	Reading	Correction Factor	Net at 3m - Peak (dBµV/m)	Peak Limit at 3m (dBµV/m)	Margin (dB)
<b><i>H</i></b>	<b><i>2390.000</i></b>	<b><i>55.9</i></b>	<b><i>-3.5</i></b>	<b><i>52.4</i></b>	<b><i>74.0</i></b>	<b><i>-21.6</i></b>
<b><i>H</i></b>	<b><i>4804.000</i></b>	<b><i>42.1</i></b>	<b><i>6.5</i></b>	<b><i>48.6</i></b>	<b><i>74.0</i></b>	<b><i>-25.4</i></b>
<b><i>H</i></b>	<b><i>12010.000</i></b>	<b><i>31.7</i></b>	<b><i>20.1</i></b>	<b><i>51.8</i></b>	<b><i>74.0</i></b>	<b><i>-22.2</i></b>

- NOTES:
1. Peak detector is used for the emission measurement.
  2. All measurements were made at 3 meters. Radiated emissions not detected at the 3-meter distance were measured at 0.3-meter and an inverse proportional extrapolation was performed to compare the signal level to the 3-meter limit. No other radiated emissions than those reported were detected at a test distance of 0.3-meter.
  3. Negative value in the margin column shows emission below limit.
  4. Horn antenna is used for the emission over 1000MHz.
  5. Emission (the row indicated by ***bold italic***) within the restricted band meets the requirement of FCC Part 15 Section 15.205 / RSS-Gen Section 8.10.

**TEST REPORT**

Mode: TX-Channel 20

Table 2

Polarization	Frequency (MHz)	Reading	Correction Factor	Net at 3m - Peak (dBµV/m)	Average Factor (dB)	Calculated at 3m (dBµV/m)	Average Limit at 3m (dBµV/m)	Margin (dB)
<i>H</i>	<i>4884.000</i>	<i>41.5</i>	<i>6.7</i>	<i>48.2</i>	<i>0</i>	<i>48.2</i>	<i>54.0</i>	<i>-5.8</i>
<i>H</i>	<i>7326.000</i>	<i>35.1</i>	<i>13.7</i>	<i>48.8</i>	<i>0</i>	<i>48.8</i>	<i>54.0</i>	<i>-5.2</i>
<i>H</i>	<i>12210.000</i>	<i>31.7</i>	<i>20.5</i>	<i>52.2</i>	<i>0</i>	<i>52.2</i>	<i>54.0</i>	<i>-1.8</i>

Polarization	Frequency (MHz)	Reading	Correction Factor	Net at 3m - Peak (dBµV/m)	Peak Limit at 3m (dBµV/m)	Margin (dB)
<i>H</i>	<i>4884.000</i>	<i>41.5</i>	<i>6.7</i>	<i>48.2</i>	<i>74.0</i>	<i>-25.8</i>
<i>H</i>	<i>7326.000</i>	<i>35.1</i>	<i>13.7</i>	<i>48.8</i>	<i>74.0</i>	<i>-25.2</i>
<i>H</i>	<i>12210.000</i>	<i>31.7</i>	<i>20.5</i>	<i>52.2</i>	<i>74.0</i>	<i>-21.8</i>

- NOTES:
1. Peak detector is used for the emission measurement.
  2. All measurements were made at 3 meters. Radiated emissions not detected at the 3-meter distance were measured at 0.3-meter and an inverse proportional extrapolation was performed to compare the signal level to the 3-meter limit. No other radiated emissions than those reported were detected at a test distance of 0.3-meter.
  3. Negative value in the margin column shows emission below limit.
  4. Horn antenna is used for the emission over 1000MHz.
  5. Emission (the row indicated by ***bold italic***) within the restricted band meets the requirement of FCC Part 15 Section 15.205 / RSS-Gen Section 8.10.

**TEST REPORT**

Mode: TX-Channel 39

Table 3

Polarization	Frequency (MHz)	Reading	Correction Factor	Net at 3m - Peak (dBµV/m)	Average Factor (dB)	Calculated at 3m (dBµV/m)	Average Limit at 3m (dBµV/m)	Margin (dB)
<b><i>H</i></b>	<b><i>2483.500</i></b>	<b><i>55.7</i></b>	<b><i>-3.5</i></b>	<b><i>52.2</i></b>	<b><i>0</i></b>	<b><i>52.2</i></b>	<b><i>54.0</i></b>	<b><i>-1.8</i></b>
<b><i>H</i></b>	<b><i>4960.000</i></b>	<b><i>38.0</i></b>	<b><i>6.8</i></b>	<b><i>44.8</i></b>	<b><i>0</i></b>	<b><i>44.8</i></b>	<b><i>54.0</i></b>	<b><i>-9.2</i></b>
<b><i>H</i></b>	<b><i>7440.000</i></b>	<b><i>33.0</i></b>	<b><i>13.8</i></b>	<b><i>46.8</i></b>	<b><i>0</i></b>	<b><i>46.8</i></b>	<b><i>54.0</i></b>	<b><i>-7.2</i></b>
<b><i>H</i></b>	<b><i>12400.000</i></b>	<b><i>32.0</i></b>	<b><i>20.8</i></b>	<b><i>52.8</i></b>	<b><i>0</i></b>	<b><i>52.8</i></b>	<b><i>54.0</i></b>	<b><i>-1.2</i></b>

Polarization	Frequency (MHz)	Reading	Correction Factor	Net at 3m - Peak (dBµV/m)	Peak Limit at 3m (dBµV/m)	Margin (dB)
<b><i>H</i></b>	<b><i>2483.500</i></b>	<b><i>55.7</i></b>	<b><i>-3.5</i></b>	<b><i>52.2</i></b>	<b><i>74.0</i></b>	<b><i>-21.8</i></b>
<b><i>H</i></b>	<b><i>4960.000</i></b>	<b><i>38.0</i></b>	<b><i>6.8</i></b>	<b><i>44.8</i></b>	<b><i>74.0</i></b>	<b><i>-29.2</i></b>
<b><i>H</i></b>	<b><i>7440.000</i></b>	<b><i>33.0</i></b>	<b><i>13.8</i></b>	<b><i>46.8</i></b>	<b><i>74.0</i></b>	<b><i>-27.2</i></b>
<b><i>H</i></b>	<b><i>12400.000</i></b>	<b><i>32.0</i></b>	<b><i>20.8</i></b>	<b><i>52.8</i></b>	<b><i>74.0</i></b>	<b><i>-21.2</i></b>

- NOTES:
1. Peak detector is used for the emission measurement.
  2. All measurements were made at 3 meters. Radiated emissions not detected at the 3-meter distance were measured at 0.3-meter and an inverse proportional extrapolation was performed to compare the signal level to the 3-meter limit. No other radiated emissions than those reported were detected at a test distance of 0.3-meter.
  3. Negative value in the margin column shows emission below limit.
  4. Horn antenna is used for the emission over 1000MHz.
  5. Emission (the row indicated by ***bold italic***) within the restricted band meets the requirement of FCC Part 15 Section 15.205 / RSS-Gen Section 8.10.

**TEST REPORT**

Mode: WiFi + Bluetooth Audio Playing

Table 4

Polarization	Frequency (MHz)	Reading (dBµV)	Pre-amp (dB)	Antenna Factor (dB)	Net at 3m (dBµV/m)	Limit at 3m (dBµV/m)	Margin (dB)
V	45.124	40.4	16	10.0	34.4	40.0	-5.6
V	56.410	44.8	16	11.0	39.8	40.0	-0.2
V	191.858	34.5	16	16.0	34.5	43.5	-9.0
V	214.476	33.0	16	17.0	34.0	43.5	-9.5
<b>V</b>	<b>323.954</b>	<b>32.0</b>	<b>16</b>	<b>24.0</b>	<b>40.0</b>	<b>46.0</b>	<b>-6.0</b>
V	424.966	29.0	16	25.0	38.0	46.0	-8.0
V	485.988	33.6	16	26.0	43.6	46.0	-2.4
V	624.962	29.4	16	29.0	42.4	46.0	-3.6
H	749.960	29.5	16	30.0	43.5	46.0	-2.5
<b>H</b>	<b>972.002</b>	<b>23.0</b>	<b>16</b>	<b>33.0</b>	<b>40.0</b>	<b>54.0</b>	<b>-14.0</b>

- NOTES:
1. Quasi-Peak detector is used for the emission measurement.
  2. All measurements were made at 3 meters. Radiated emissions not detected at the 3-meter distance were measured at 0.3-meter and an inverse proportional extrapolation was performed to compare the signal level to the 3-meter limit. No other radiated emissions than those reported were detected at a test distance of 0.3-meter.
  3. Negative value in the margin column shows emission below limit.
  4. Emission (the row indicated by **bold italic**) within the restricted band meets the requirement of FCC Part 15 Section 15.205 / RSS-Gen Section 8.10.

## TEST REPORT

### 4.6.3 Radiated Emission Test Setup

The figure below shows the test setup, which is utilized to make these measurements.

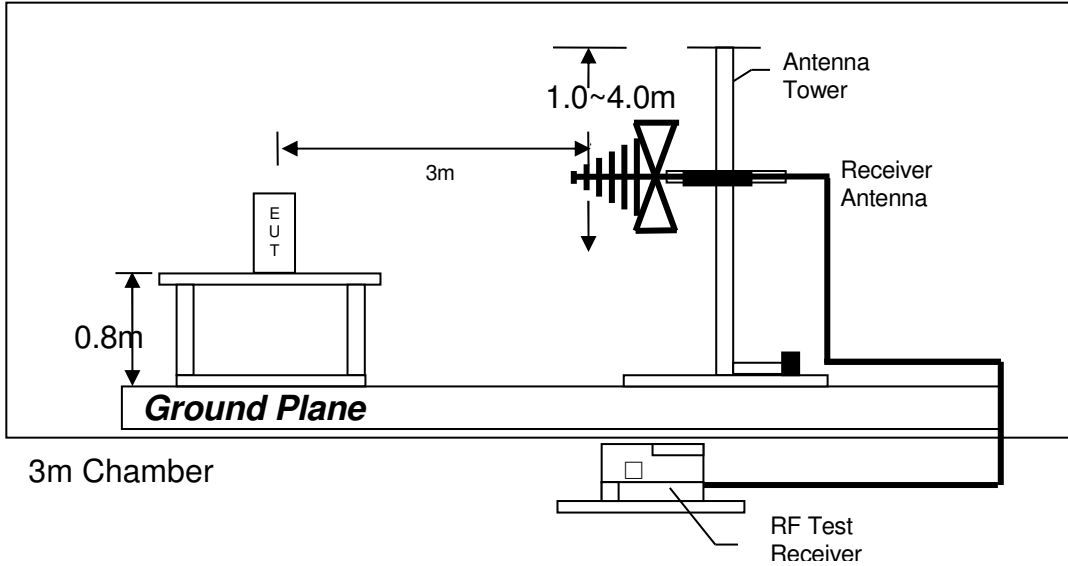

Test setup of radiated emissions up to 1GHz

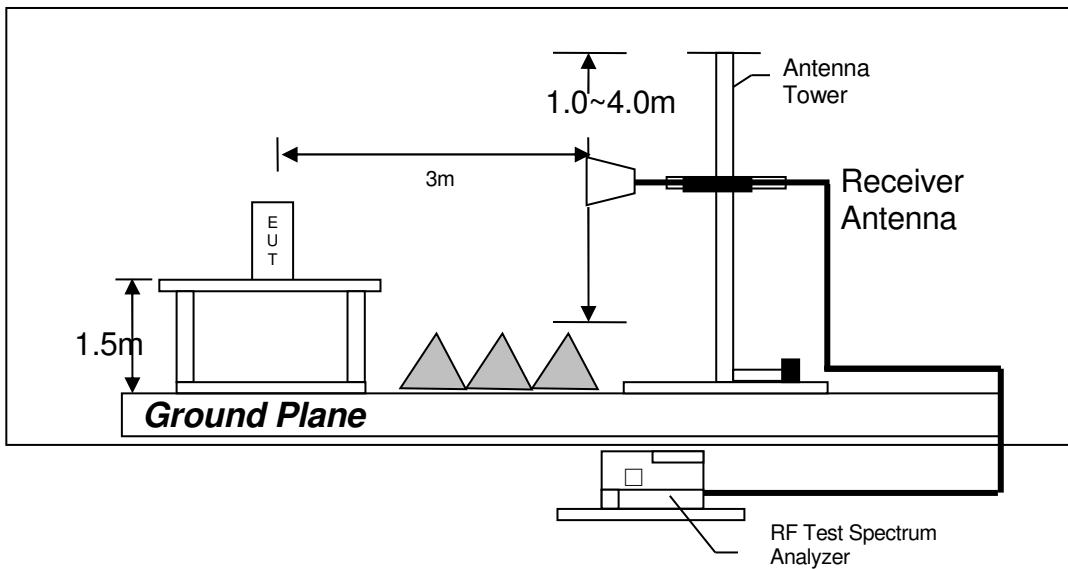

Test setup of radiated emissions above 1GHz

## TEST REPORT

### 4.6.4 Transmitter Duty Cycle Calculation

Not applicable – No average factor is required.

## TEST REPORT

### 4.7 AC Power Line Conducted Emission

- Not applicable – EUT is only powered by battery for operation.
- EUT connects to AC power line. Emission Data is listed in following pages.
  
- Base Unit connects to AC power line and has transmission. Handset connects to AC power line but has no transmission. Emission Data of Base Unit is listed in following pages.

#### 4.7.1 AC Power Line Conducted Emission Configuration Photograph

Worst Case Line-Conducted Configuration  
at

0.690 MHz

The worst case line conducted configuration photographs are attached in the Appendix and saved with filename: config photos.pdf

#### 4.7.2 AC Power Line Conducted Emission Data

The plot(s) and data in the following pages list the significant emission frequencies, the limit and the margin of compliance.

Passed by 4.9 dB margin

**TEST REPORT**

**AC POWER LINE CONDUCTED EMISSION**

Worst Case: WiFi + Bluetooth Audio Playing

EDIT PEAK LIST (Final Measurement Results)				
Trace1:	CF15MQP			
Trace2:	CF15MAV			
Trace3:	---			
TRACE	FREQUENCY	LEVEL dBµV		DELTA LIMIT dB
2 CISPR Average	195 kHz	43.36	N	-10.45
1 Quasi Peak	199.5 kHz	51.54	L1	-12.08
1 Quasi Peak	222 kHz	42.78	N	-19.95
2 CISPR Average	276 kHz	35.28	L1	-15.64
2 CISPR Average	294 kHz	36.73	L1	-13.67
1 Quasi Peak	370.5 kHz	34.23	L1	-24.25
1 Quasi Peak	492 kHz	44.14	N	-11.99
2 CISPR Average	492 kHz	39.92	L1	-6.20
1 Quasi Peak	690 kHz	45.99	L1	-10.00
2 CISPR Average	690 kHz	41.12	L1	-4.87
1 Quasi Peak	852 kHz	39.06	L1	-16.93
2 CISPR Average	883.5 kHz	38.95	N	-7.04
2 CISPR Average	1.2795 MHz	39.50	N	-6.49
1 Quasi Peak	1.473 MHz	39.98	N	-16.02
2 CISPR Average	1.671 MHz	35.33	N	-10.66
1 Quasi Peak	1.869 MHz	38.79	N	-17.20
1 Quasi Peak	2.157 MHz	33.40	N	-22.60
2 CISPR Average	2.3595 MHz	32.32	L1	-13.67
1 Quasi Peak	3.93 MHz	33.08	L1	-22.91
2 CISPR Average	3.9345 MHz	30.14	L1	-15.85

Date: 28.JAN.2019 07:46:25



**TEST REPORT**

Worst Case: WiFi + Bluetooth Audio Playing

EDIT PEAK LIST (Final Measurement Results)				
Trace1:	CF15MQP			
Trace2:	CF15MAV			
Trace3:	---			
TRACE	FREQUENCY	LEVEL dBµV		DELTA LIMIT dB
1 Quasi Peak	4.317 MHz	28.11	N	-27.88
2 CISPR Average	4.722 MHz	31.04	N	-14.95
2 CISPR Average	5.8965 MHz	28.41	N	-21.59
1 Quasi Peak	6.099 MHz	37.91	L1	-22.09
1 Quasi Peak	8.151 MHz	33.86	N	-26.13
2 CISPR Average	8.1555 MHz	24.62	N	-25.37
1 Quasi Peak	12.2865 MHz	43.72	N	-16.27
2 CISPR Average	12.2865 MHz	43.69	N	-6.30
1 Quasi Peak	26.3355 MHz	29.45	L1	-30.54

Date: 28.JAN.2019 07:47:02

**TEST REPORT**

Worst Case: WiFi + Bluetooth Audio Playing



RBW 9 kHz

MT 1 s

Att 10 dB AUTO PREAMP OFF

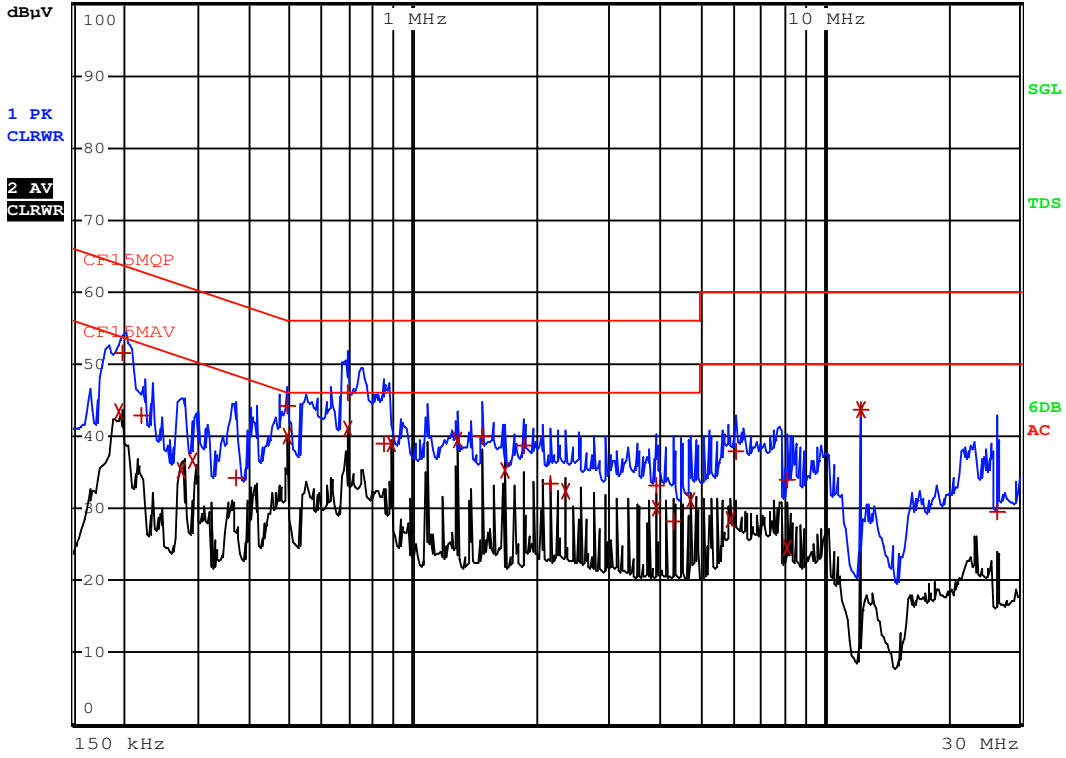

Date: 28.JAN.2019 07:47:42

## TEST REPORT

### 4.7.3 Conducted Emission Test Setup

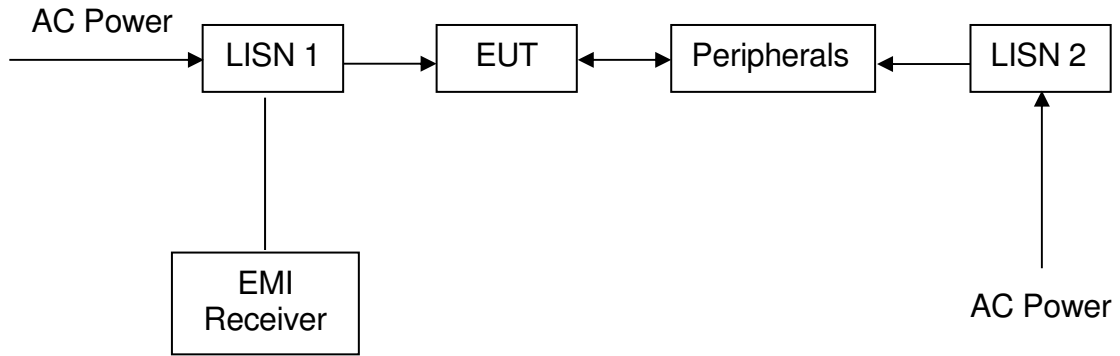

**TEST REPORT**

4.8 Occupied Bandwidth

Occupied Bandwidth Results:

Bluetooth (MHz)	Occupied Bandwidth (MHz)	
Low Channel:	2402	1.032
Middle Channel:	2442	1.044
High Channel:	2480	1.032

The worst case is shown as below

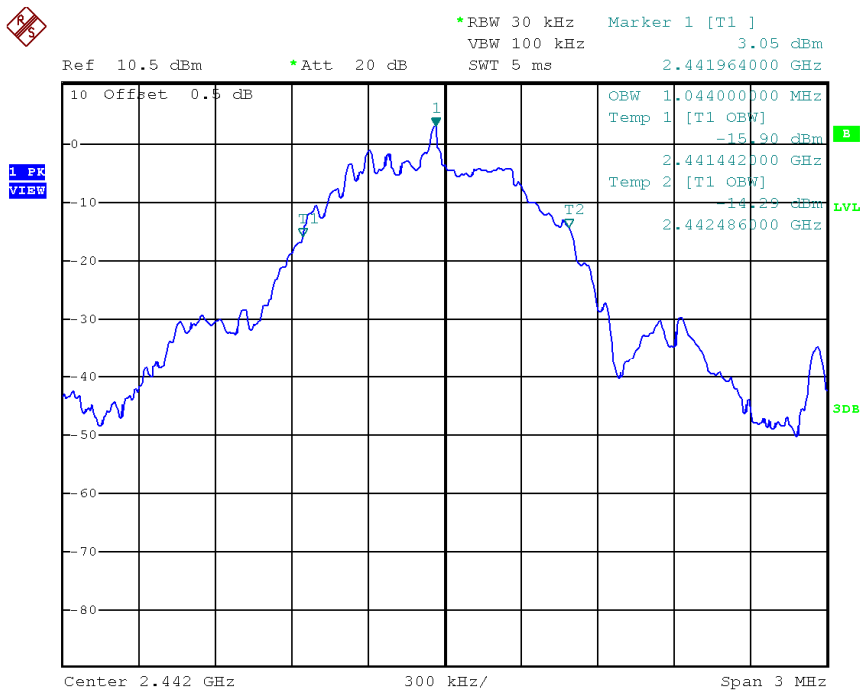

## TEST REPORT

### 5.0 EQUIPMENT LIST

#### 1) Radiated Emissions Test

Equipment	EMI Test Receiver	Spectrum Analyzer	Biconical Antenna
Registration No.	EW-2666	EW-3110	EW-0571
Manufacturer	R&S	R&S	EMCO
Model No.	ESCI7	FSP30	3104C
Calibration Date	August 28, 2018	March 05, 2018	February 27, 2018
Calibration Due Date	August 28, 2019	March 05, 2019	August 27, 2019

Equipment	Log Periodic Antenna	Double Ridged Guide Antenna	14m Double Shield RF Cable (20MHz to 6GHz)
Registration No.	EW-0447	EW-1015	EW-2505
Manufacturer	EMCO	EMCO	RADIALL
Model No.	3148	3115	nm / br5d / sma 14m
Calibration Date	January 17, 2018	November 17, 2017	October 27, 2018
Calibration Due Date	July 17, 2019	May 17, 2019	October 27, 2019

Equipment	RF Cable 14m (1GHz to 26.5GHz)	RF Pre-amplifier 3 pcs (9kHz to 40GHz)	Pyramidal Horn Antenna
Registration No.	EW-2781	EW-3006	EW-0905
Manufacturer	GREATBILLION	SCHWARZBECK	EMCO
Model No.	SMA m/SHF5MPU /SMA m ra14m,26G	BBV 9718 BBV9744 BBV 9721	3160-09
Calibration Date	October 27, 2018	April 26, 2018	August 18, 2017
Calibration Due Date	October 27, 2019	April 26, 2019	February 18, 2019

Equipment	Active Loop H-field (9kHz to 30MHz)	Notch Filter (cutoff frequency 2.4GHz to 2.5GHz)
Registration No.	EW-2313	EW-2213
Manufacturer	ELECTROMETRI	MICROTRONICS
Model No.	EM-6876	BRM50701-02
Calibration Date	March 08, 2018	May 24, 2018
Calibration Due Date	September 08, 2019	May 24, 2019

## TEST REPORT

### 2) Conductive Measurement Test

Equipment	Spectrum Analyzer	RF Cable (up to 40GHz) 1.5m length	RF Power Meter with Power Sensor (N1921A)
Registration No.	EW-3110	EW-3104	EW-3309
Manufacturer	R&S	N/A	ROHDESCHWARZ
Model No.	FSP30	SMA-M to SMA-M	NRP-Z81
Calibration Date	March 05, 2018	July 03, 2018	July 02, 2018
Calibration Due Date	March 05, 2019	July 03, 2019	May 28, 2019

### 3) Bandedge/Bandwidth Measurement

Equipment	RF Cable (up to 40GHz) 1.5m length	Spectrum Analyzer
Registration No.	EW-3104	EW-3110
Manufacturer	N/A	R&S
Model No.	SMA-M to SMA-M	FSP30
Calibration Date	July 03, 2018	March 05, 2018
Calibration Due Date	July 03, 2019	March 05, 2019

### 4) Conducted Emissions Test

Equipment	Artificial Mains Network	RF Cable 240cm (RG142)	EMI Test Receiver
Registration No.	EW-2501	EW-2454	EW-2666
Manufacturer	ROHDESCHWARZ	RADIALL	R&S
Model No.	ENV-216	bnc m st / 142 /bnc m ra 240cm	ESCI7
Calibration Date	Feb. 14, 2018	March 27, 2018	August 28, 2018
Calibration Due Date	Feb. 14, 2019	March 27, 2019	August 28, 2019

**END OF TEST REPORT**