

2110 - 2155 MHz Band

Lower Band Edge

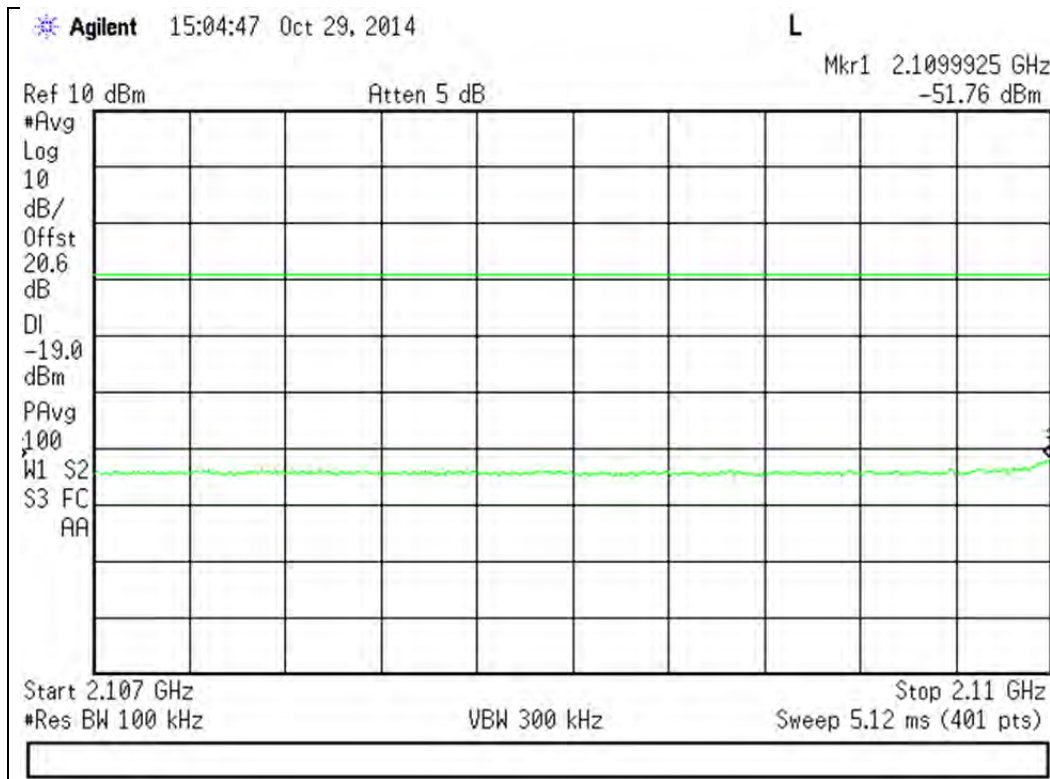

Upper Band Edge

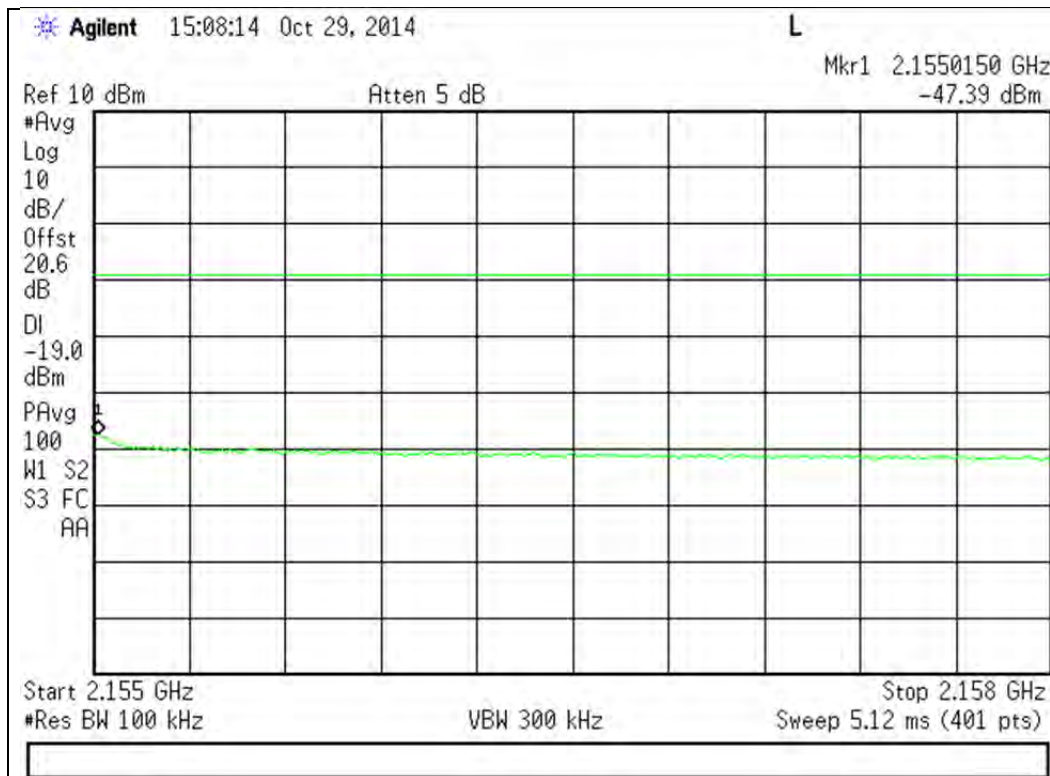

Conducted Spurious Emissions

Engineer: Mike Graffeo

Test Date: 10/28/14

Test Procedure

The EUT was connected to a spectrum analyzer through an attenuator, with the losses being input into the spectrum analyzer as a combination of reference level offset and correction factor as needed to ensure accurate readings. A signal generator was utilized to produce a 4.1 MHz AWGN signal operating at the maximum allowable power. The conducted spurious emissions from 9 kHz to 10 times the highest tunable frequency for each operational band were measured (excluding the band defined by the Out of band emissions test). The emissions were plotted and the highest level was recorded in the summary table.

The following formulas are used for calculating the limits.

Conducted Spurious Emissions Limit = $P1 - (43 + 10\text{Log}(P2)) = -13 \text{ dBm}$

P1 = power in dBm

P2 = power in Watts

Test Setup

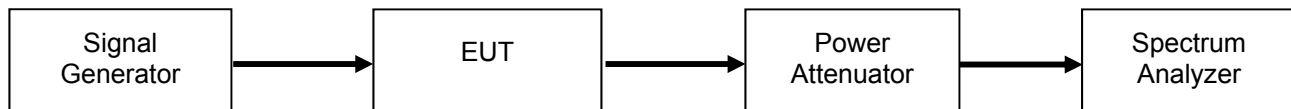

Uplink Test Results

Frequency Band (MHz)	Measured Frequency (MHz)	Measured Level (dBm)	Limit (dBm)	Result
698 - 716	1754.6	-32.44	-13	Pass
776 - 787	787.1	-19.12	-13	Pass
824 - 849	1880.7	-32.75	-13	Pass
1710 - 1755	1886.2	-33.59	-13	Pass
1850 - 1915	1755.3	-32.10	-13	Pass

Downlink Test Results

Frequency Band (MHz)	Measured Frequency (MHz)	Measured Level (dBm)	Limit (dBm)	Result
728 - 746	1969.0	-31.27	-13	Pass
746 - 757	1970.6	-31.65	-13	Pass
869 - 894	1964.6	-32.64	-13	Pass
1930 - 1995	2154.3	-33.94	-13	Pass
2110 - 2155	1965.6	-32.82	-13	Pass

For the 746 – 758 downlink and 776 – 788 Uplink bands of operation, the following additional spurious emissions requirements apply.

FCC 27.53(c)

For operations in the 746-758 MHz band and the 776-788 MHz band, the power of any emission outside the licensee's frequency band(s) of operation shall be attenuated below the transmitter power (P) within the licensed band(s) of operation, measured in watts, in accordance with the following:

(3) On all frequencies between 763-775 MHz and 793-805MHz, by a factor of not less than $76 + 10 \log (P)$ dB in a 6.25 kHz band segment, for base and fixed stations;

The test is performed using a 10 kHz RBW. Since the limit is referenced to a 6.25 kHz BW, the following correction factor is applied to the measured data.

BW correction Factor = $10\log B1/B2$

BW correction Factor = $10\log 6.25 / 10 = - 2.0$ dB

Final Value (dBm) = conducted measurement +BW correction factor

776 – 787 MHz Uplink Band

Spurious Frequency Range (MHz)	Measured Frequency (MHz)	Measured Value (dBm)	Bandwidth Correction Factor (dB)	Final Value (dBm)	Limit (dBm)	Margin (dB)
763 – 775	774.96	-56.80	-2.0	-58.84	-46	-12.84
793 – 805	793	-71.48	-2.0	-73.52	-46	-27.52

746 - 757 MHz Downlink Band

Spurious Frequency Range (MHz)	Measured Frequency (MHz)	Measured Value (dBm)	Bandwidth Correction Factor (dB)	Final Value (dBm)	Limit (dBm)	Margin (dB)
763 – 775	772.89	-86.00	-2.0	-88.04	-46	-42.04
793 – 805	794.65	-84.21	-2.0	-86.25	-46	-40.25

FCC 27.53(f)

For operations in the 746-758 MHz, 775-788 MHz, and 805-806 MHz bands, emissions in the band 1559-1610 MHz shall be limited to -70 dBW/MHz equivalent isotropically radiated power (EIRP) for wideband signals, and -80 dBW EIRP for discrete emissions of less than 700 Hz bandwidth. For the purpose of equipment authorization, a transmitter shall be tested with an antenna that is representative of the type that will be used with the equipment in normal operation.

Since the limit is referenced to EIRP, the final data is computed using the Conducted Spurious Emission data and adding the BW correction factor plus the final gain/loss data from the antenna kitting information supplied by the manufacturer.

For the Narrowband measurement, the test is performed using a 10 kHz RBW. Since the limit is referenced to a 700 Hz BW, the following correction factor is applied to the measured data.

BW correction Factor = $10\log B1/B2$

BW correction Factor = $10\log 700 / 10000 = -11.55$ dB

Final Value (dBm) = conducted measurement + BW correction factor + final gain/loss from Antenna Kitting document

The Limit for discreet (narrowband) emissions is -80dBW (-50 dBm) in 700 MHz BW.

The Limit for (wideband Emissions) is -70 dBW (-40 dBm) in a 1 MHz BW.

776 – 787 MHz Uplink Band

Spurious Frequency Range (MHz)	Measured Frequency (MHz)	Measured Value (dBm)	Bandwidth Correction Factor (dB)	Gain/Loss from Antenna Kitting Information (dB)	Final Value (dBm)	Limit (dBm)	Margin (dB)
1559 – 1610 (Wideband)	1563.8	-53.8	0	2.13	-51.67	-40	-11.67
1559 – 1610 (Narrowband)	1563.9	-78.32	-11.55	2.13	-87.74	-50	-37.74

746 - 757 MHz Downlink Band

Spurious Frequency Range (MHz)	Measured Frequency (MHz)	Measured Value (dBm)	Bandwidth Correction Factor (dB)	Gain/Loss from Antenna Kitting information (dB)	Final Value (dBm)	Limit (dBm)	Margin (dB)
1559 – 1610 (Wideband)	1586.8	-59.6	0	2.13	-57.47	-40	-17.47
1559 – 1610 (Narrowband)	1600.1	-83.22	-11.55	2.13	-92.64	-50	-42.64

Uplink Test Plots

698 - 716 MHz Band

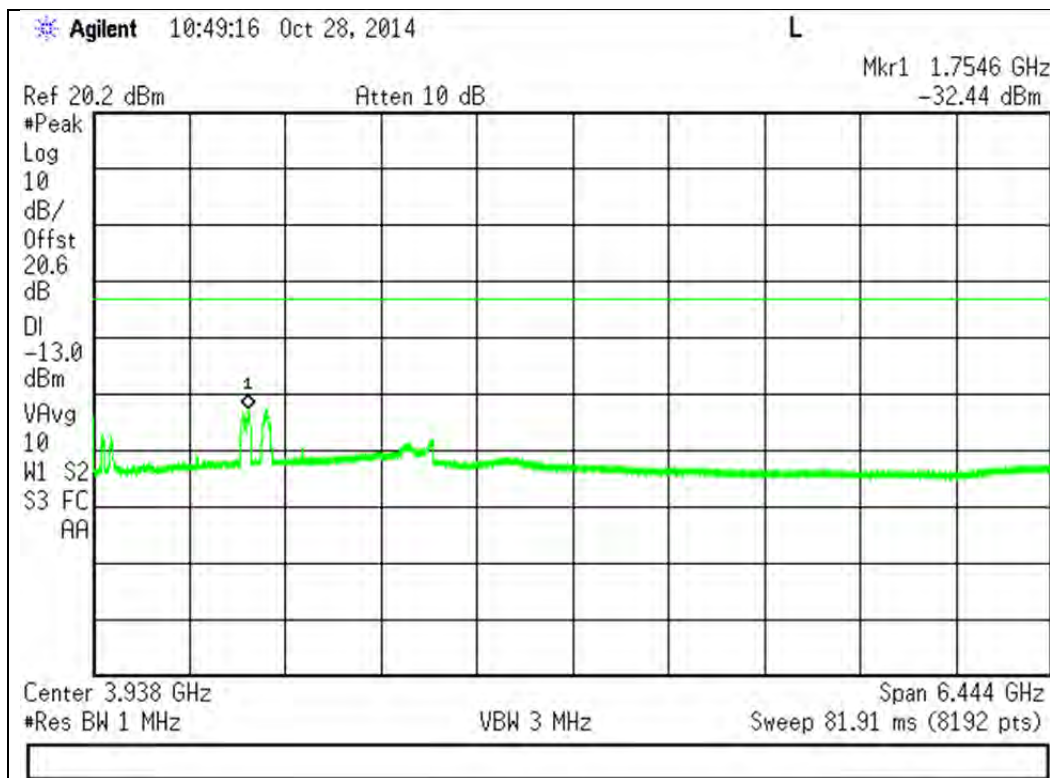
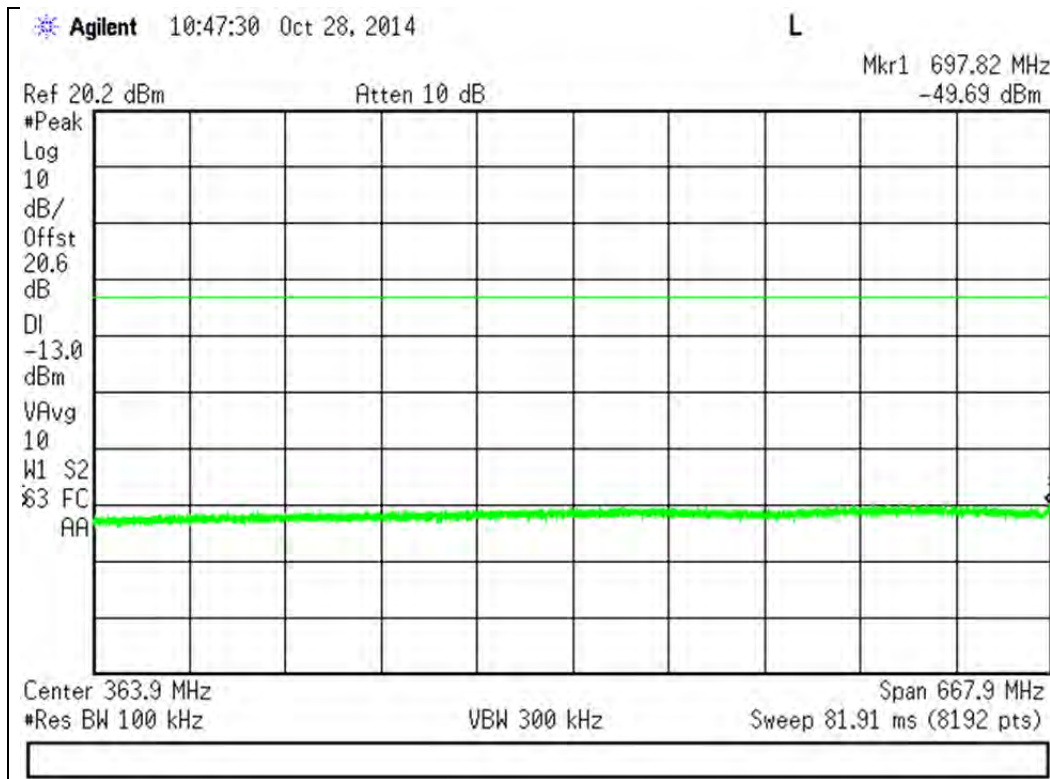

776 - 787 MHz Band

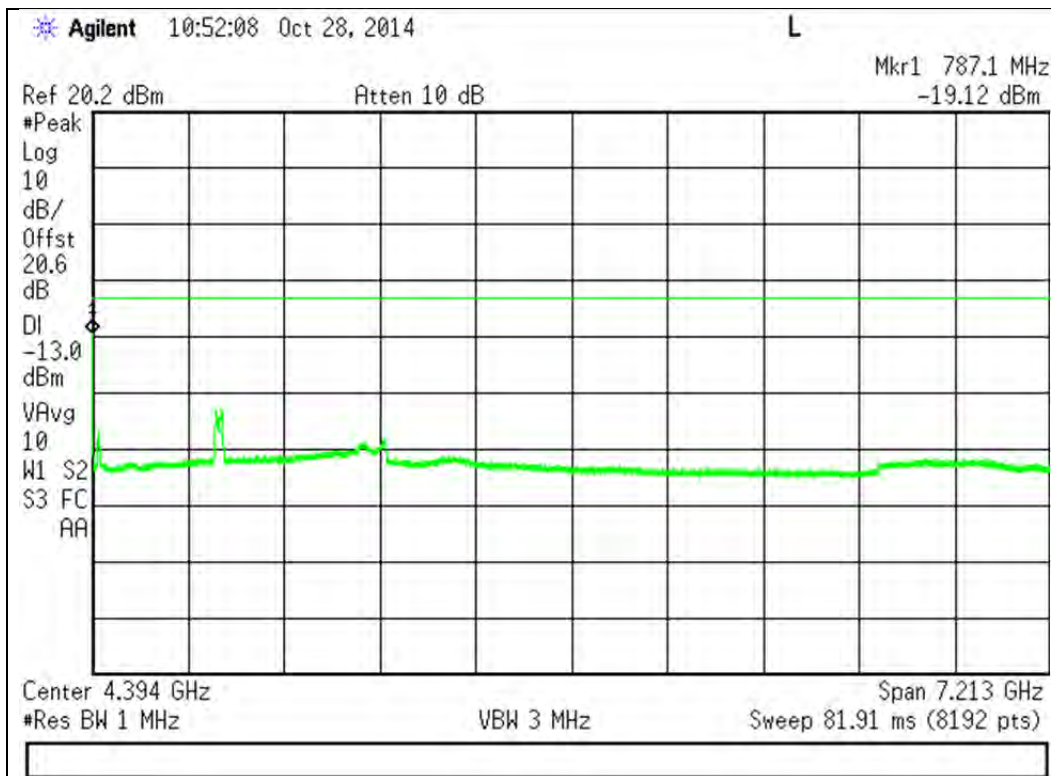
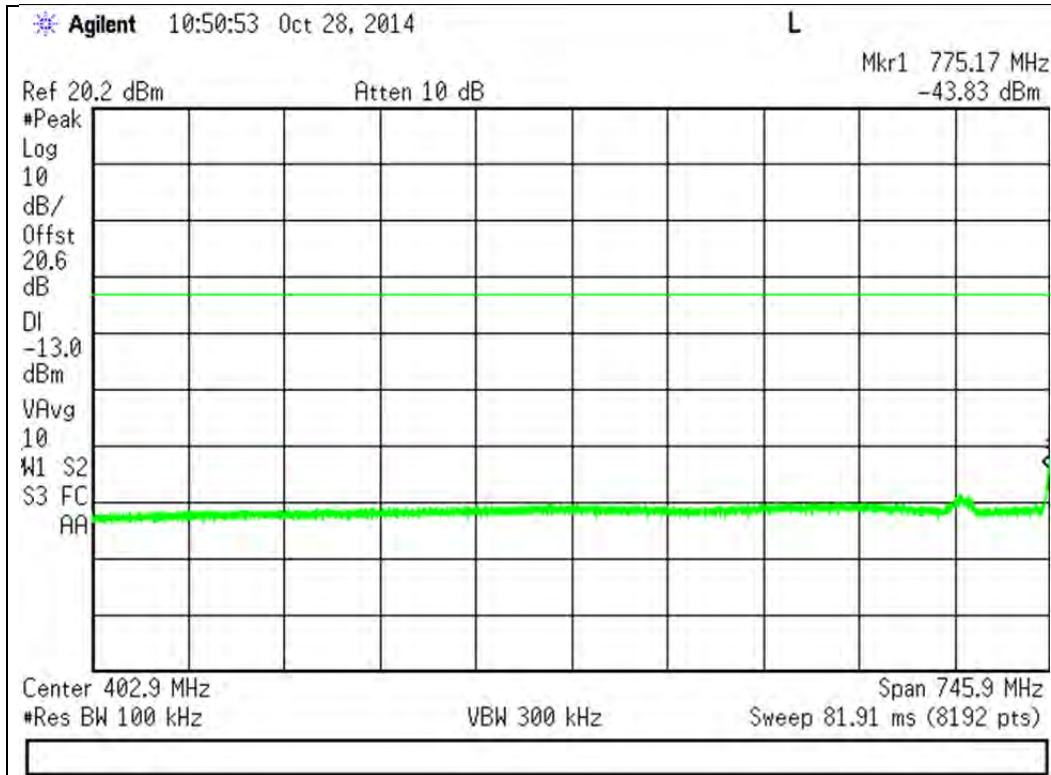

824 - 849 MHz Band

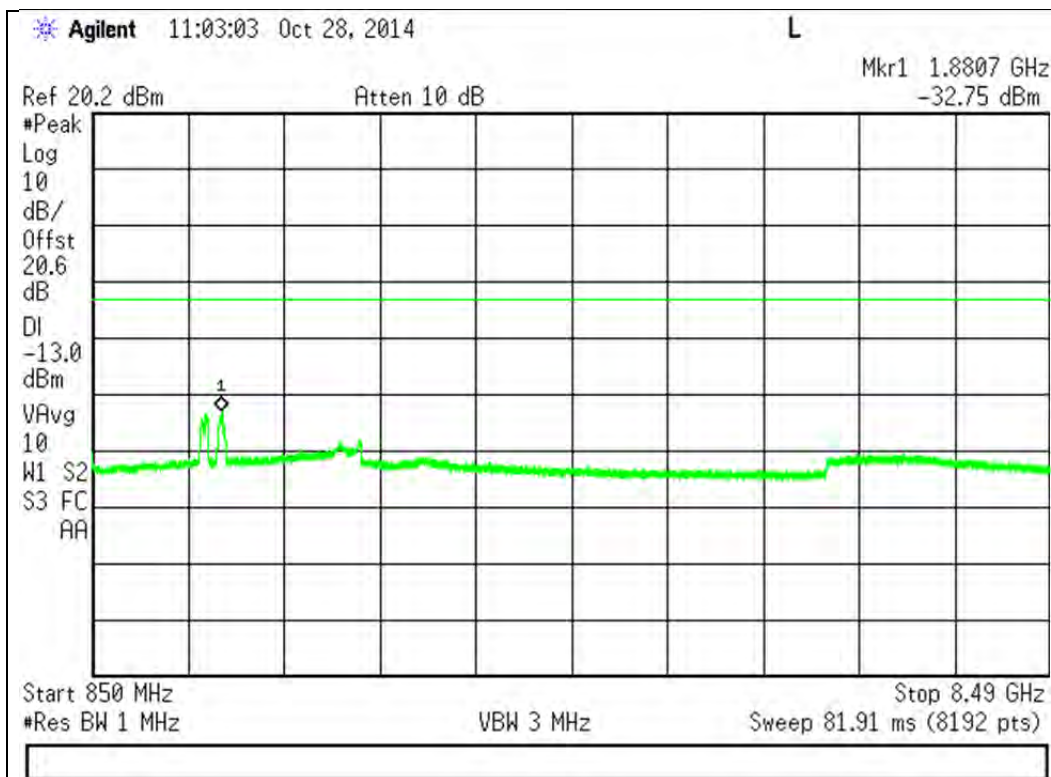
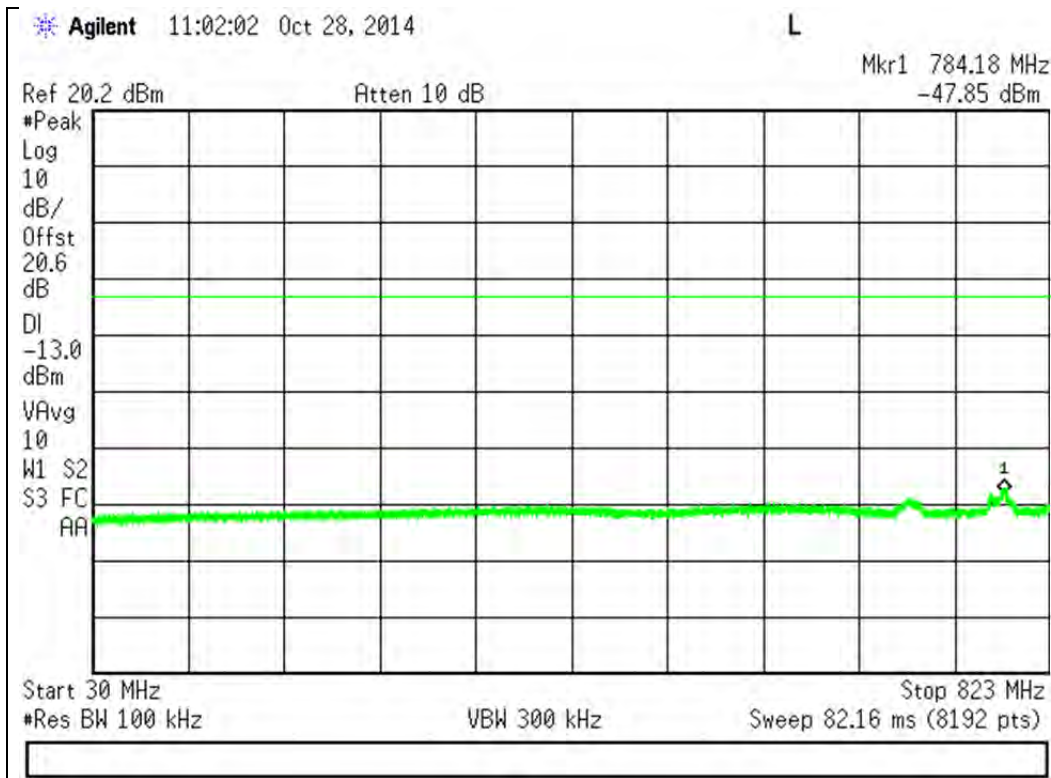

1710 - 1755 MHz Band

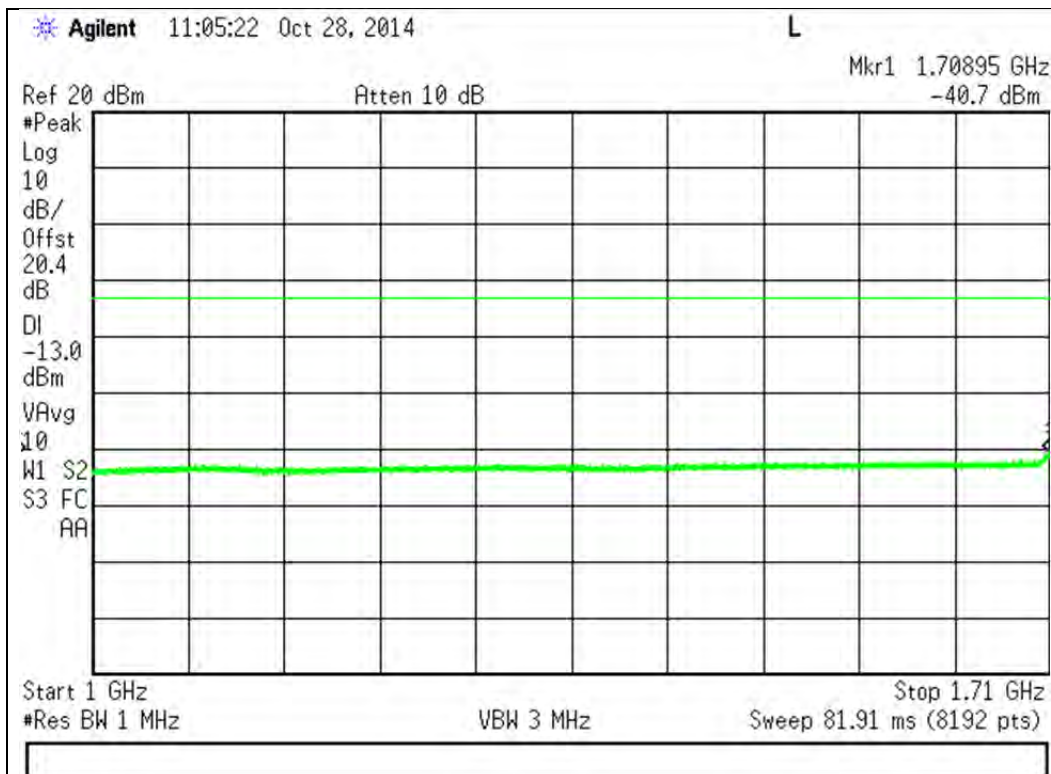
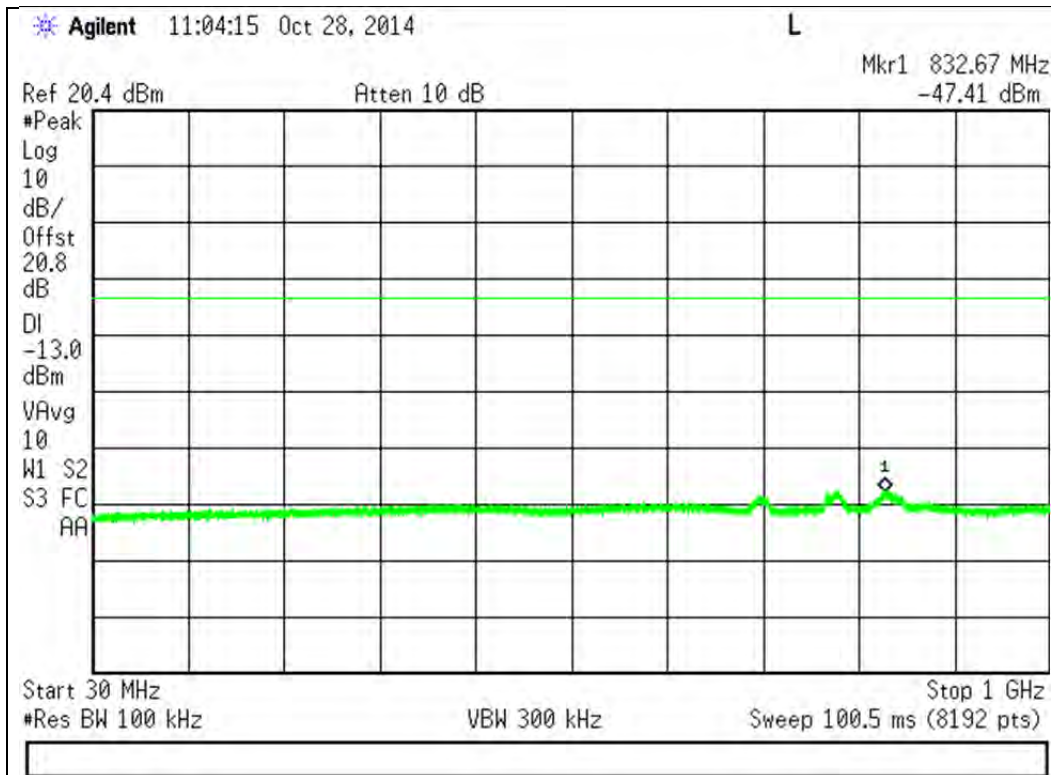

1710 - 1755 MHz Band (cont)

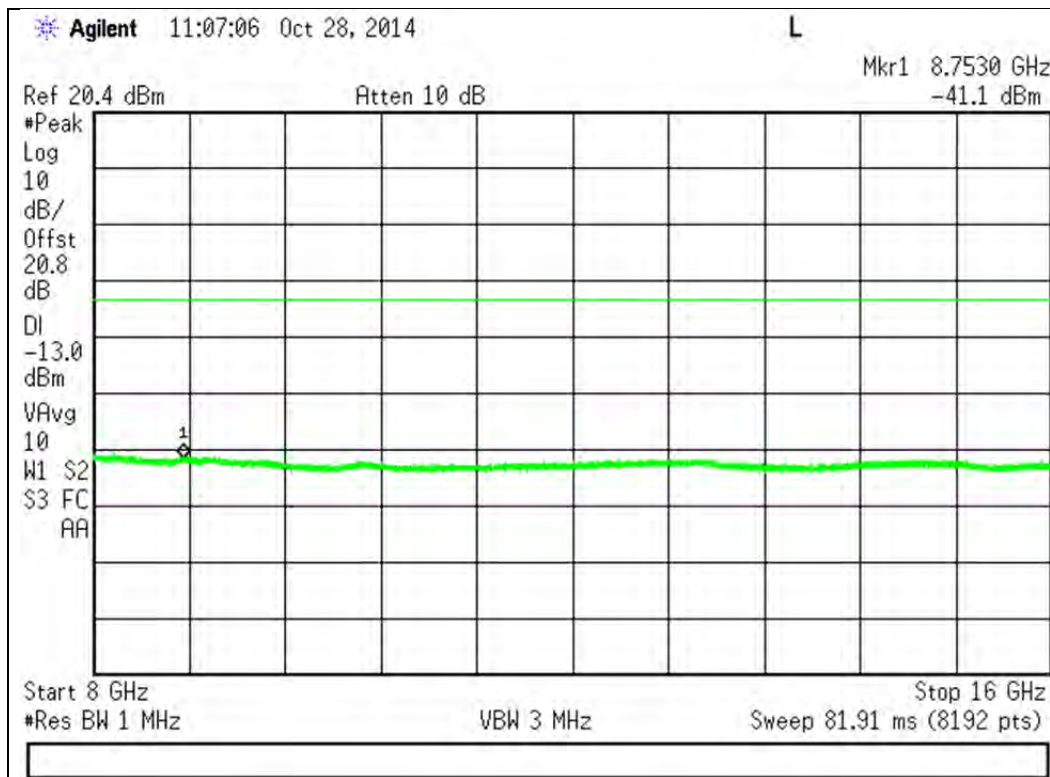
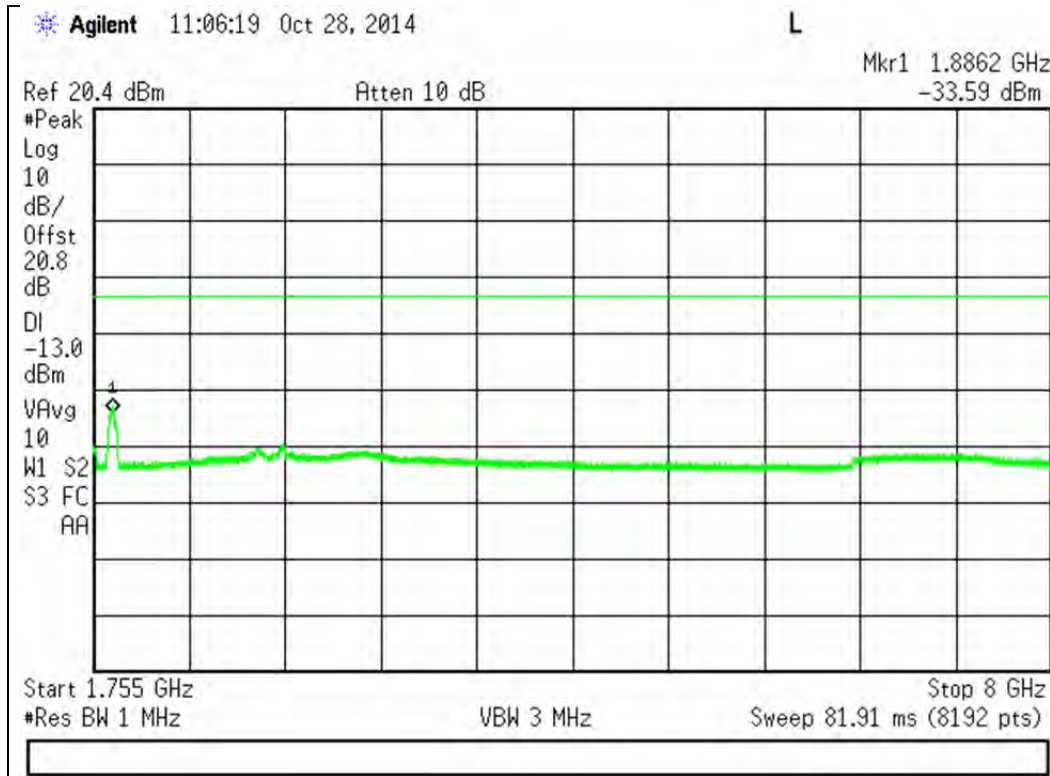

1710 - 1755 MHz Band (cont)

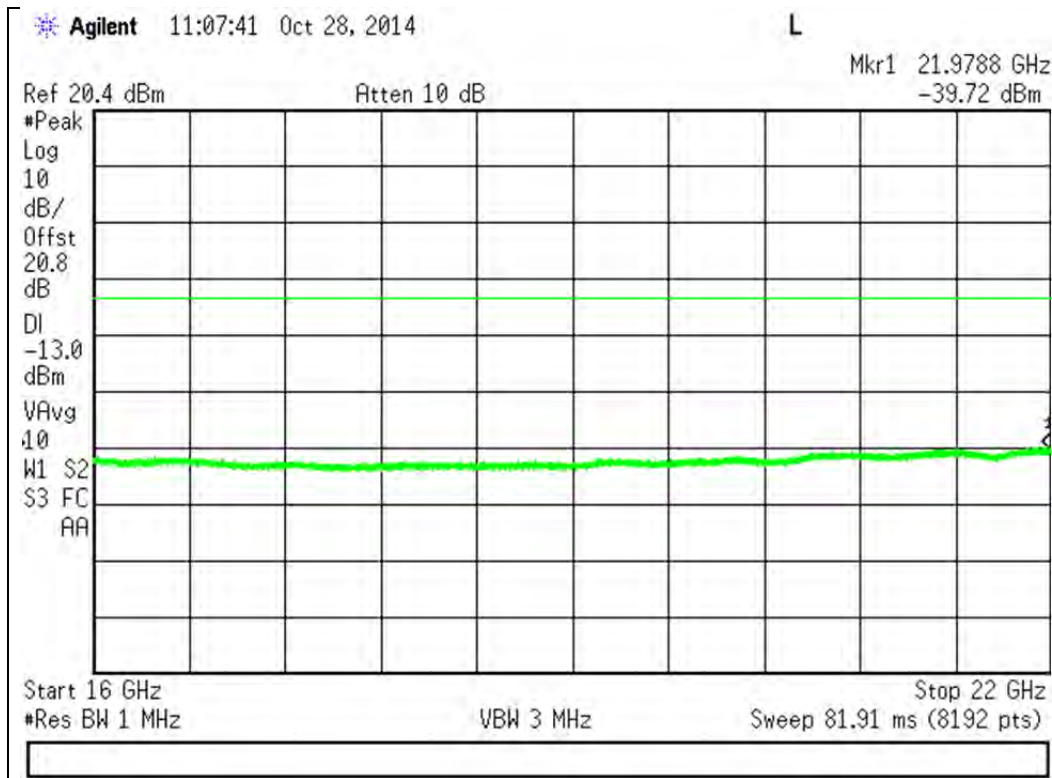

1850 - 1915 MHz Band

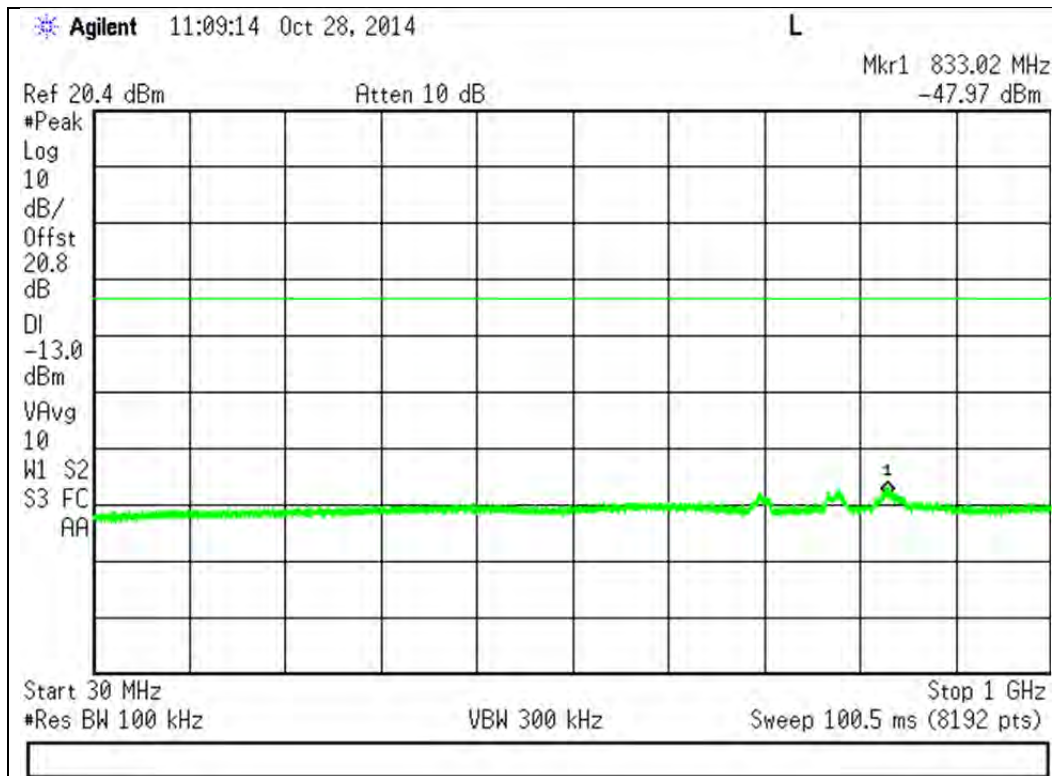

1850 - 1915 MHz Band (cont)

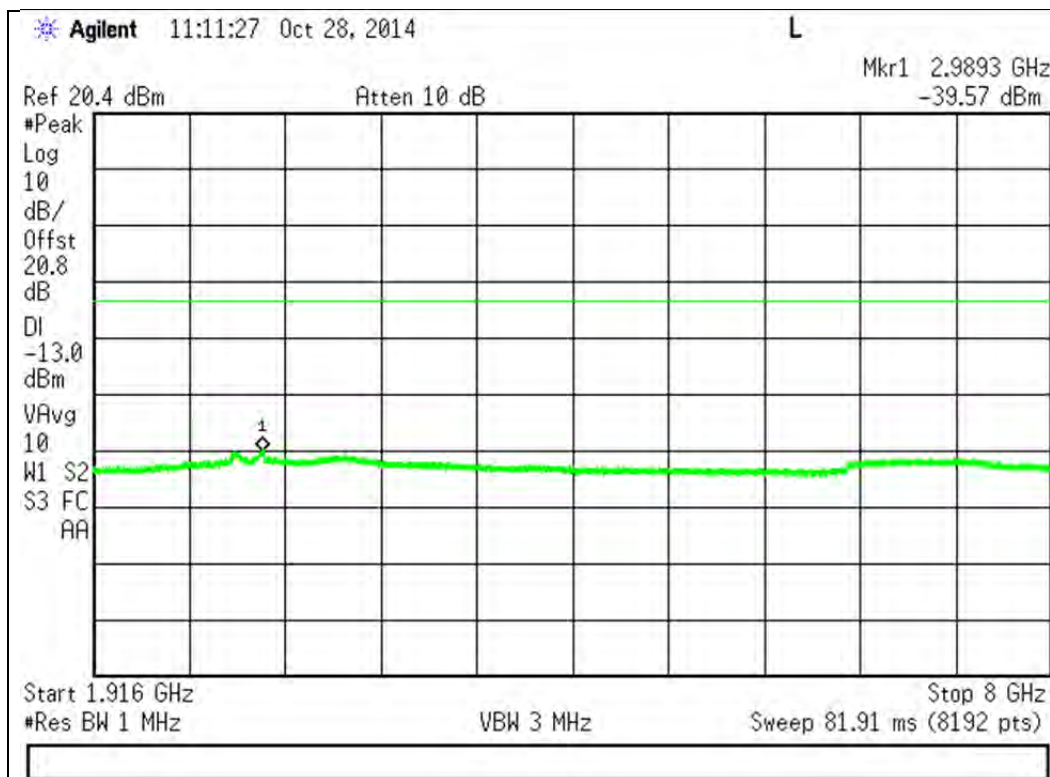
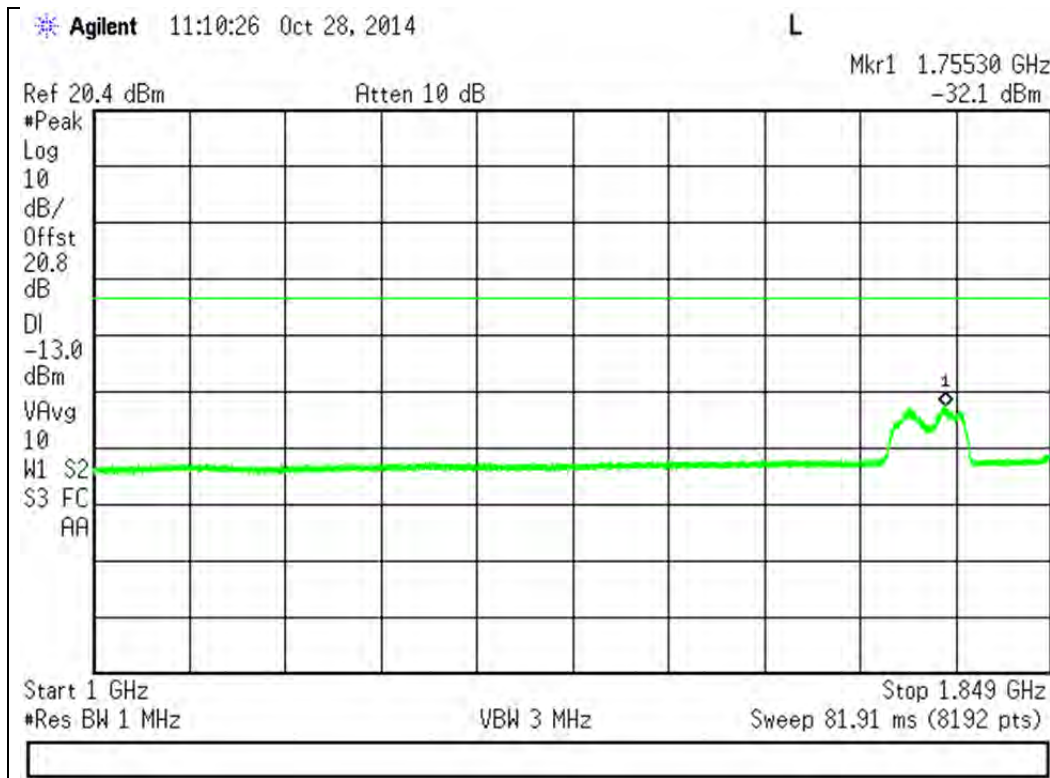

1850 - 1915 MHz Band (cont)

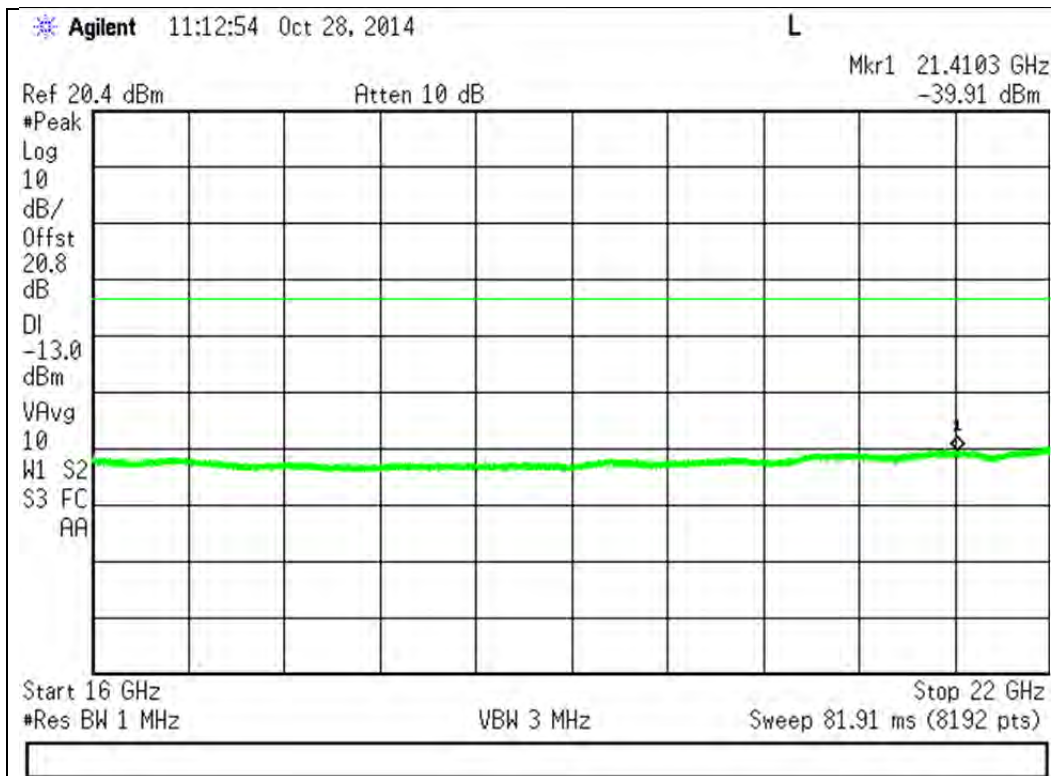
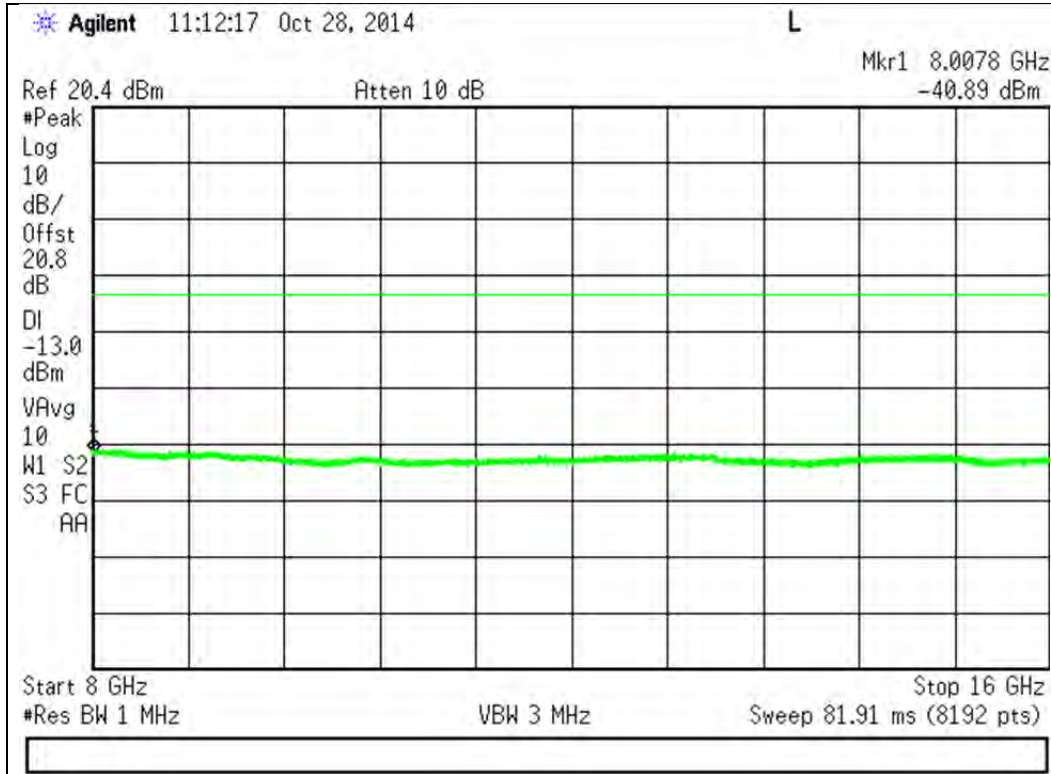

Downlink Test Plots

728 - 746 MHz Band

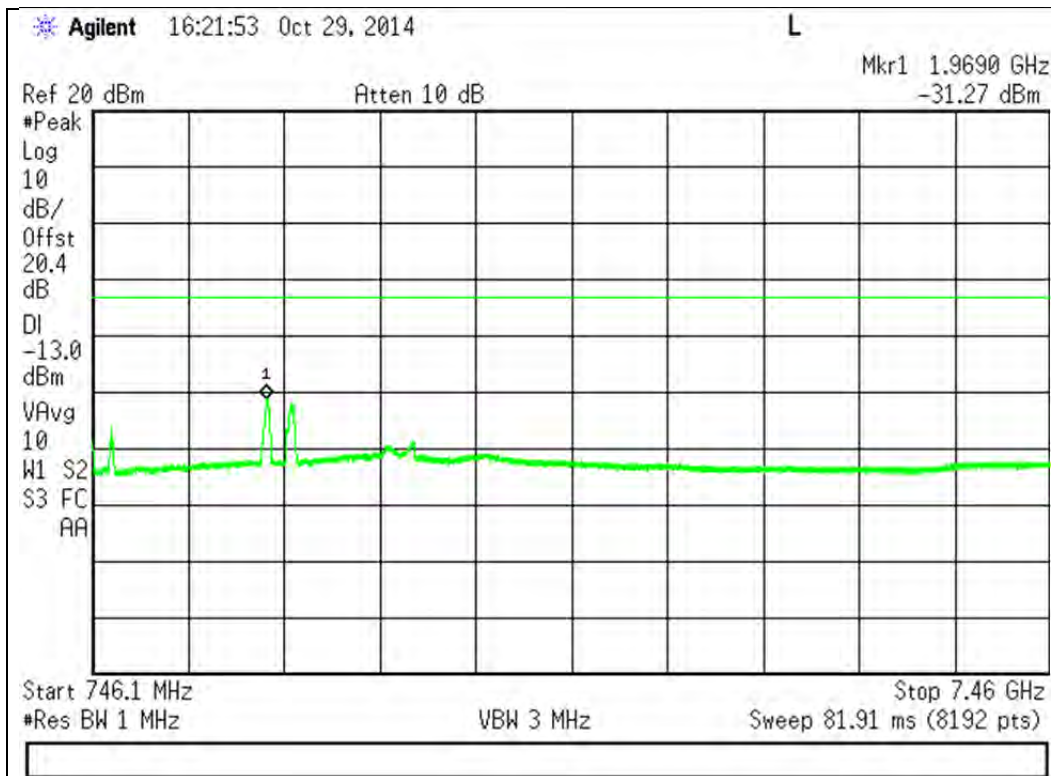
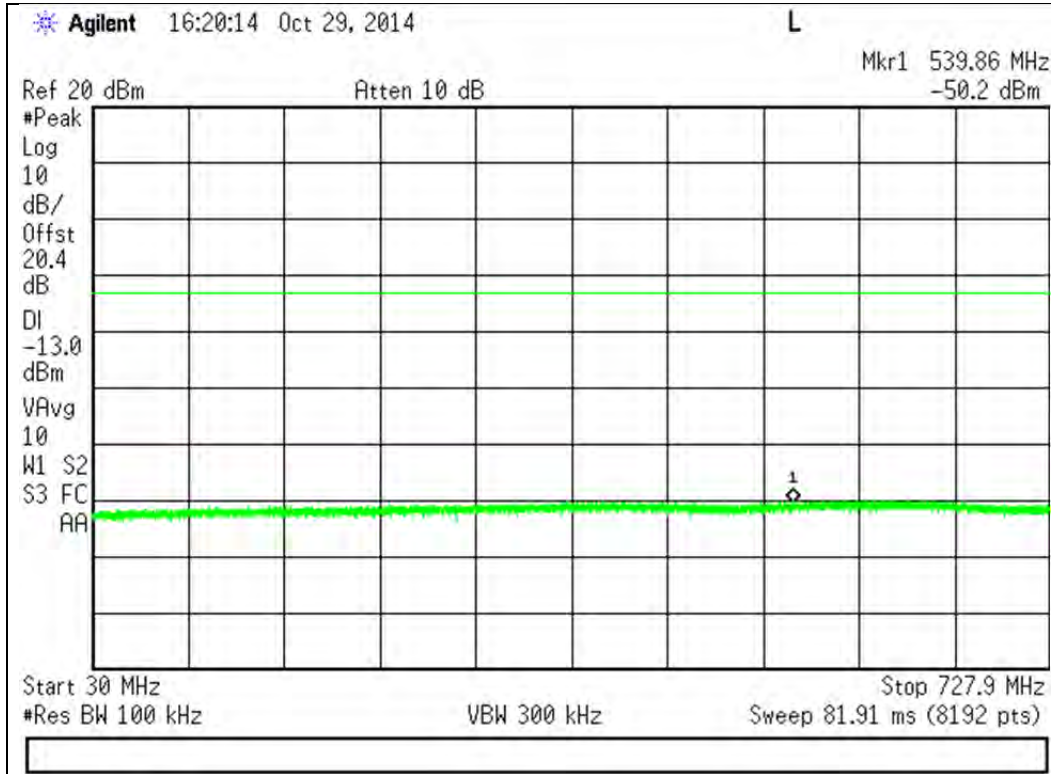

746 - 757 MHz Band

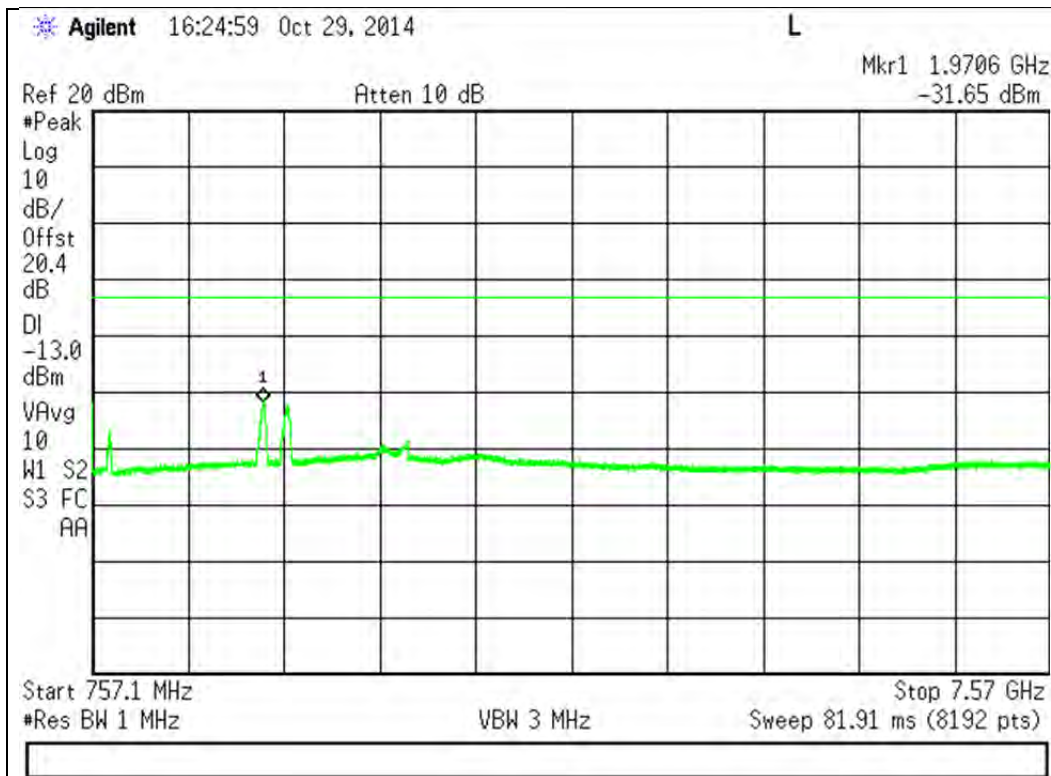
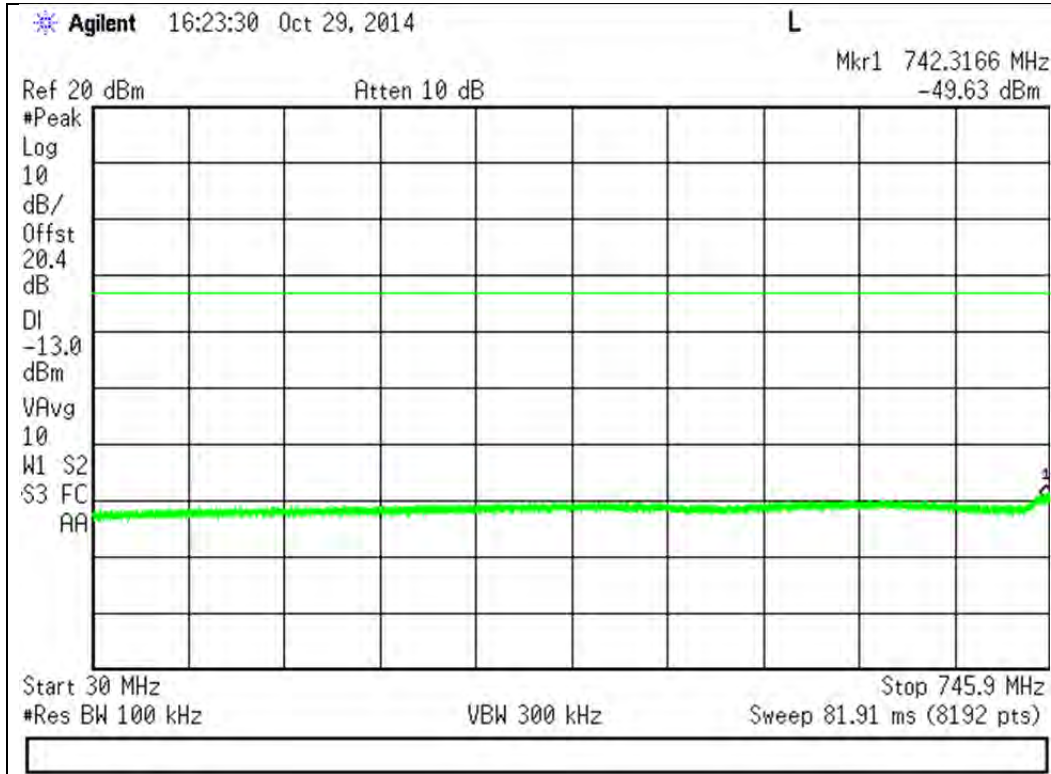

869 - 894 MHz Band

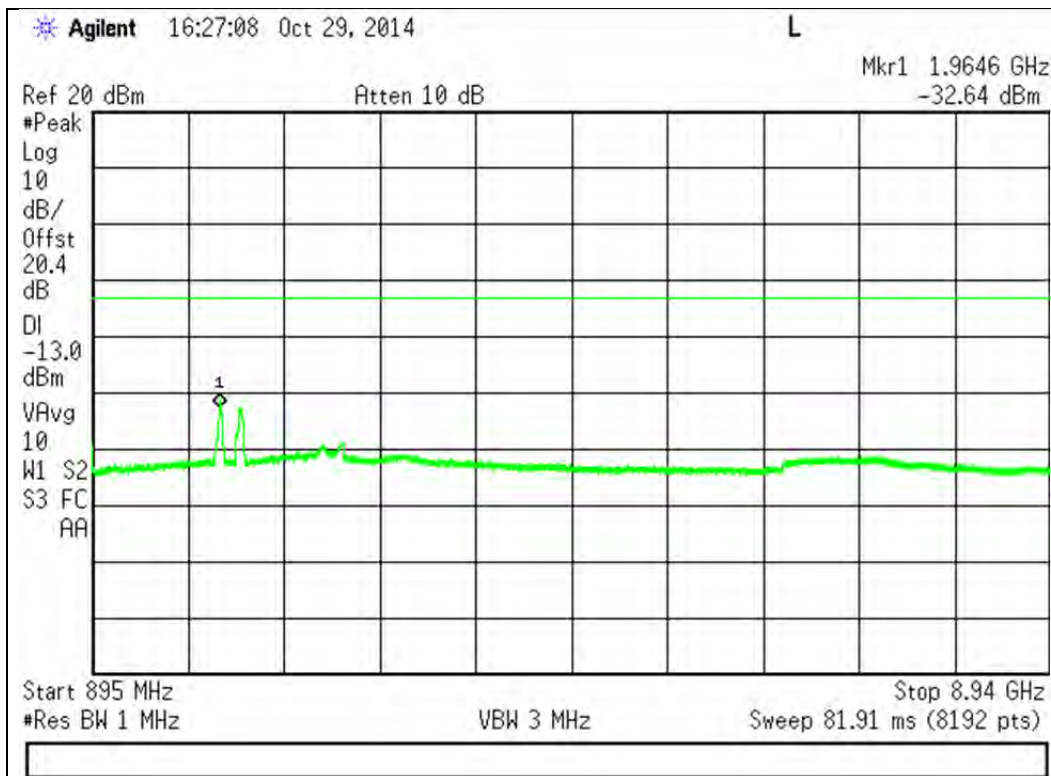
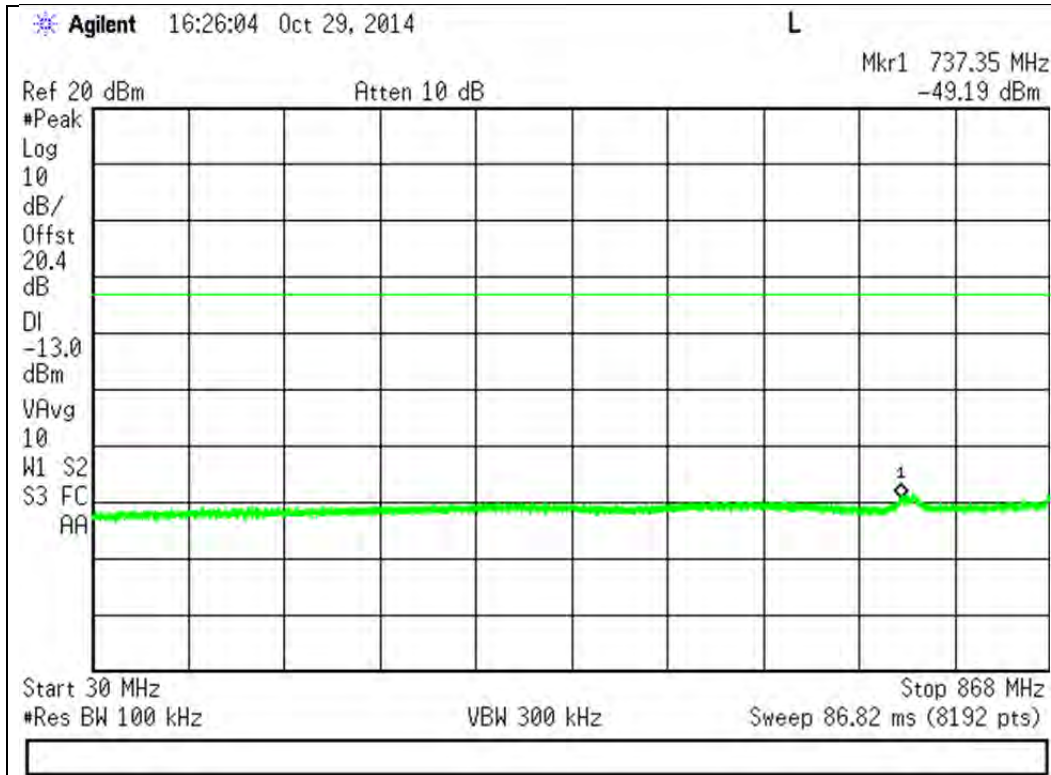

1930 - 1995 MHz Band

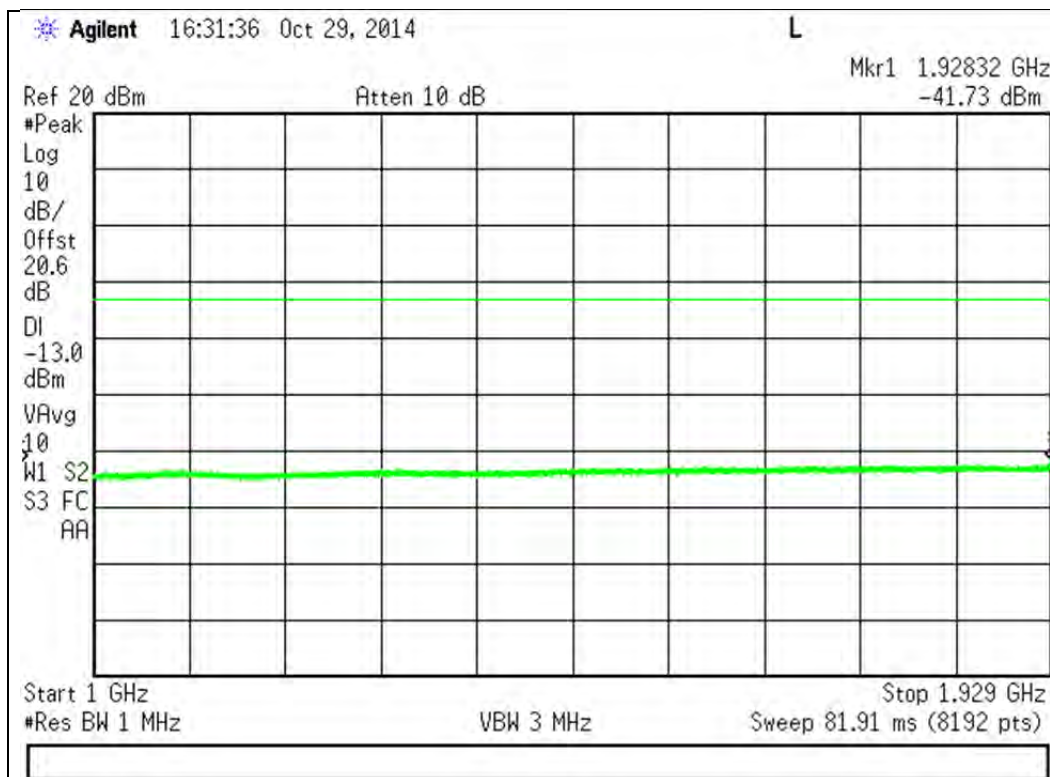
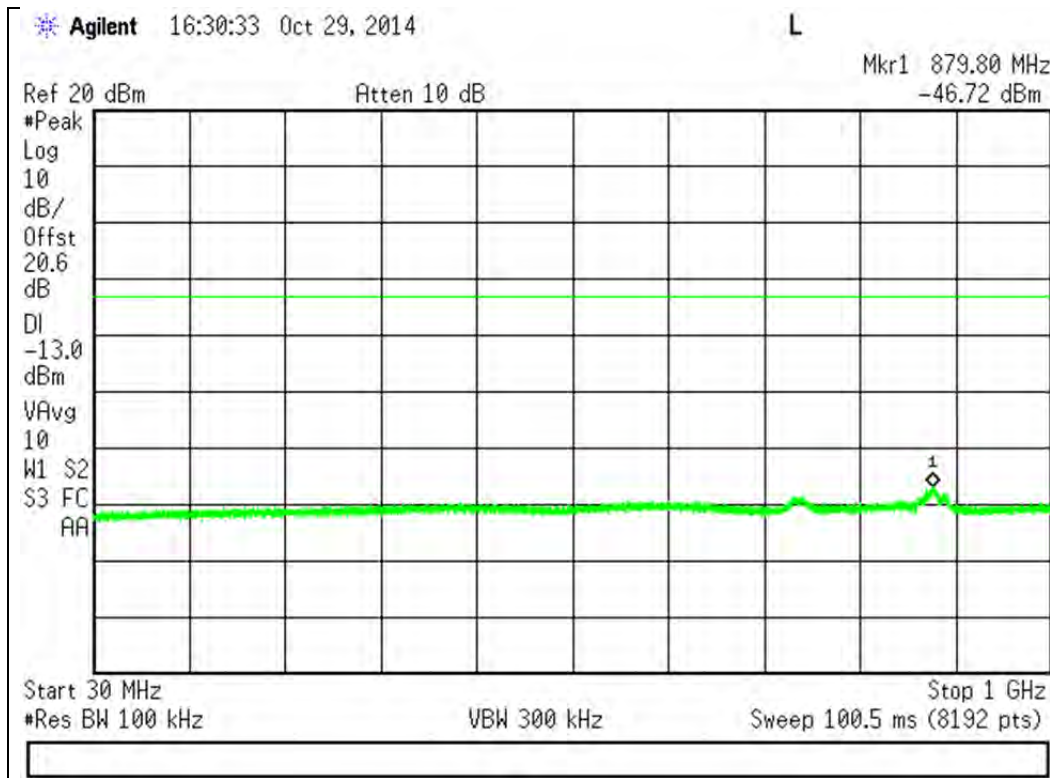

1930 - 1995 MHz Band (cont)

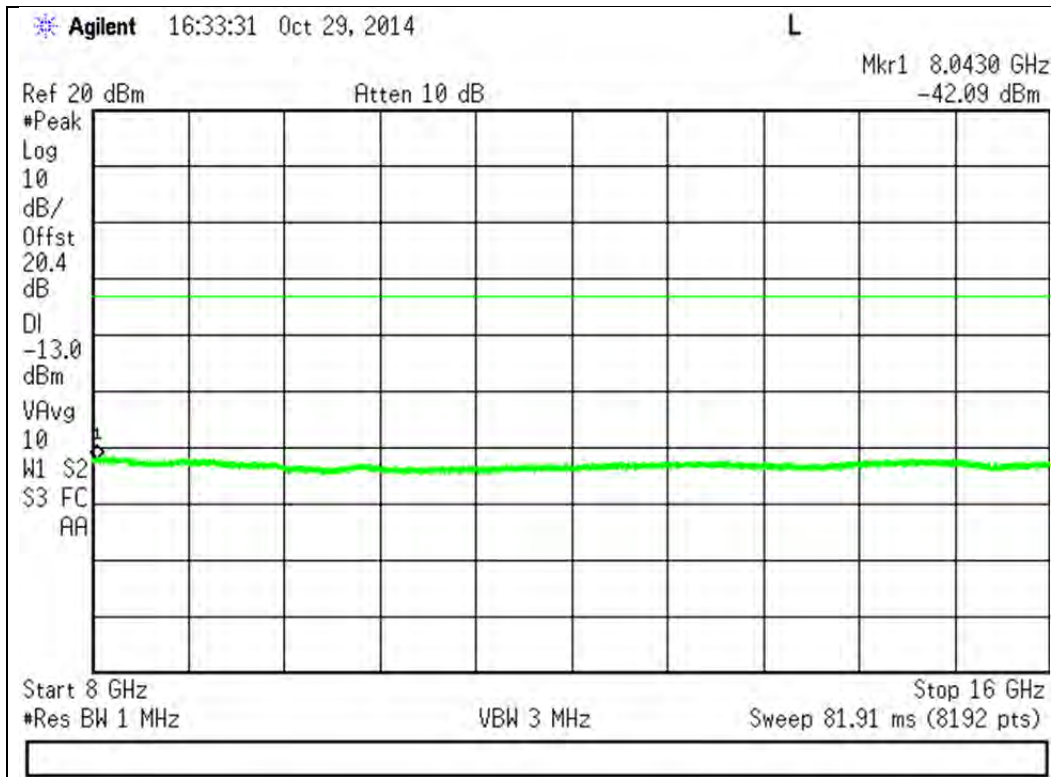
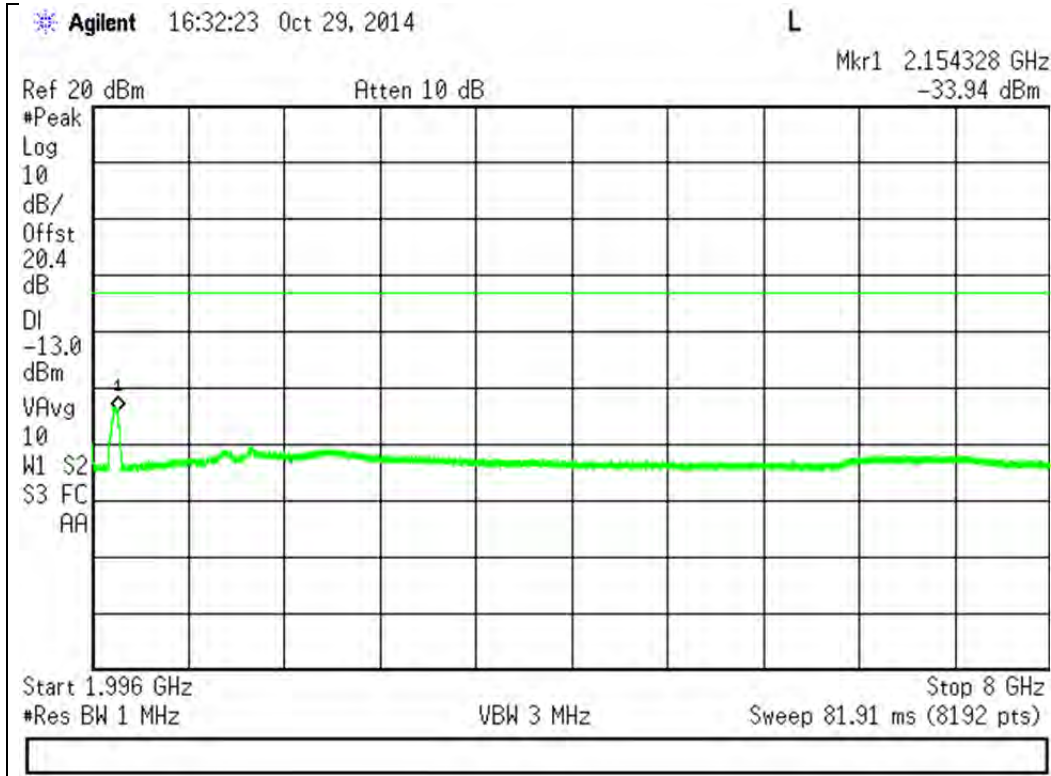

1930 - 1995 MHz Band (cont)

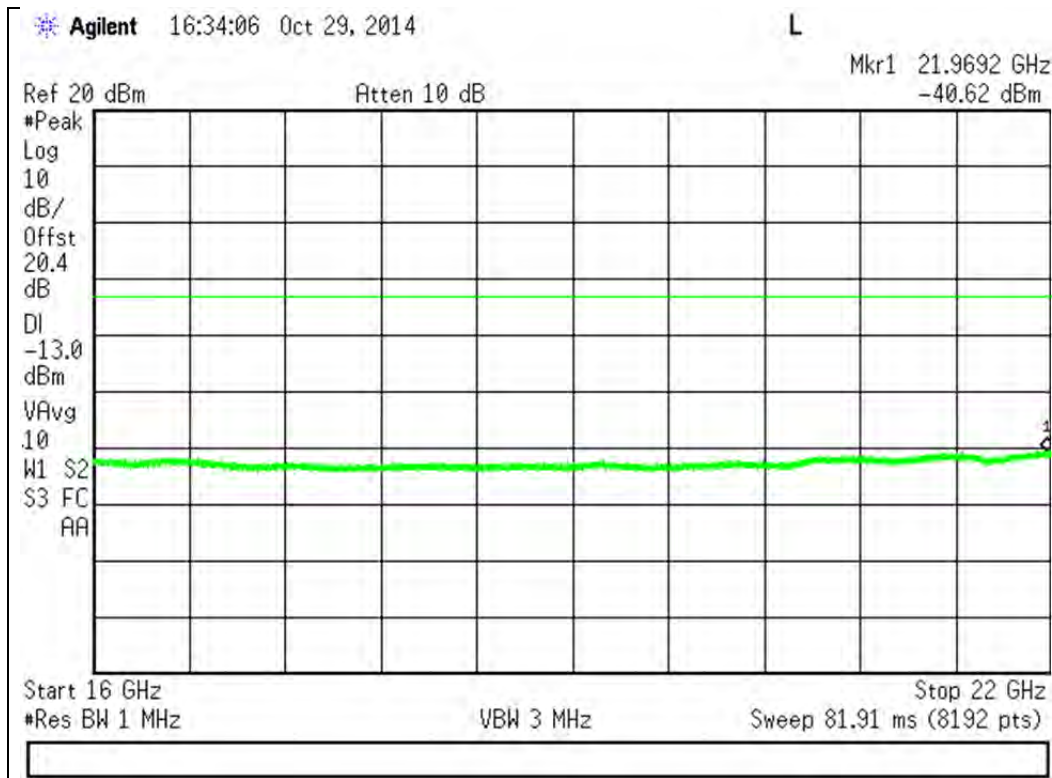

2110 - 2155 MHz Band

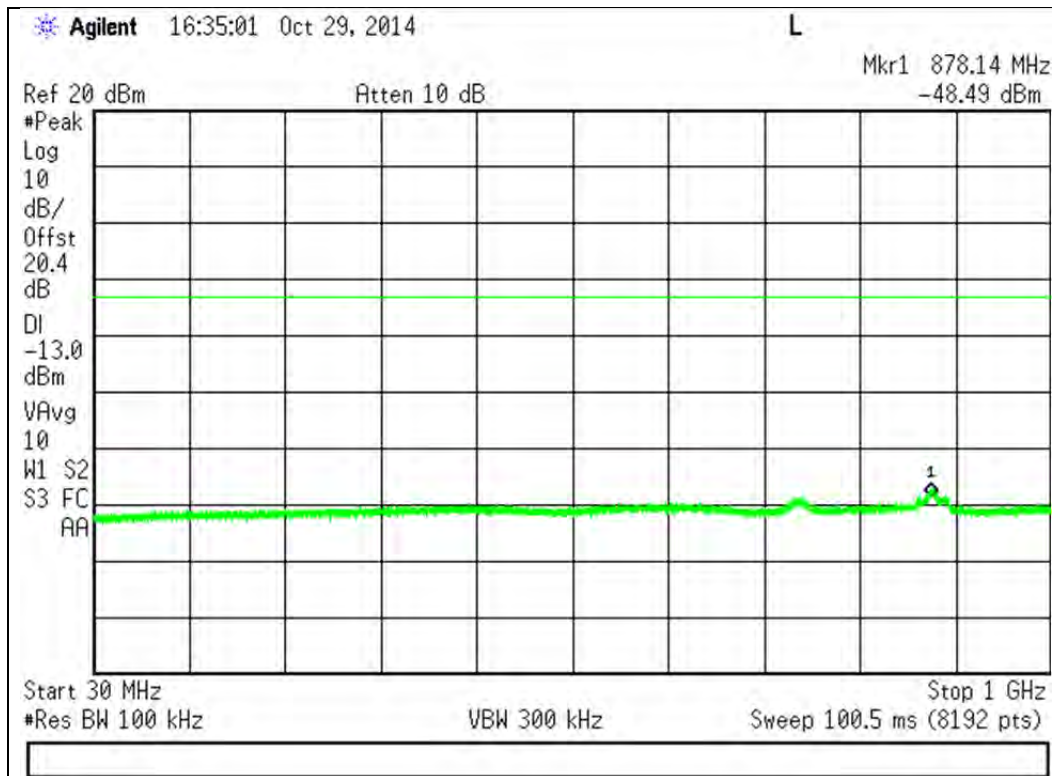

2110 - 2155 MHz Band (cont)

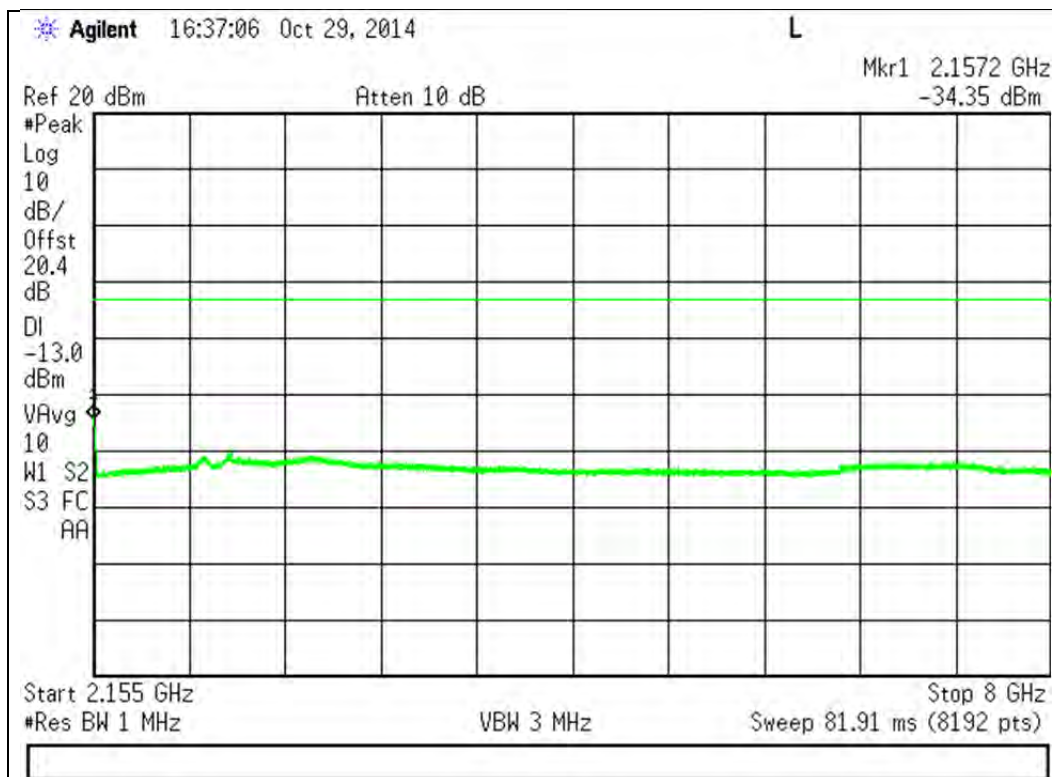
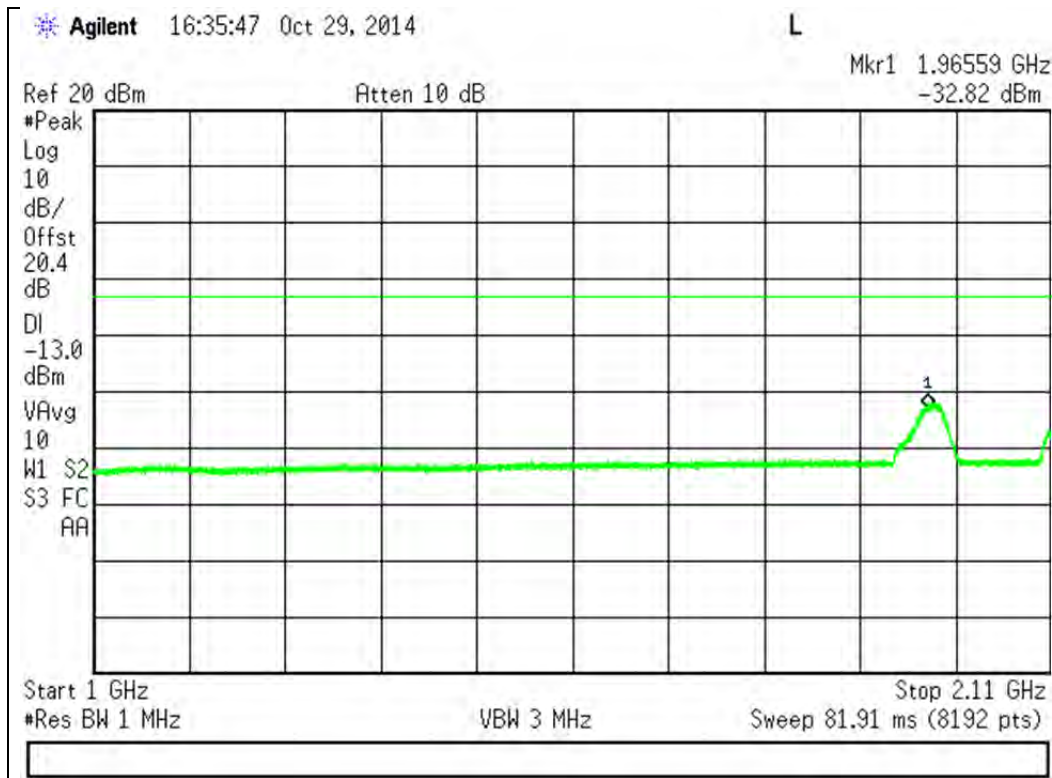

2110 - 2155 MHz Band (cont)

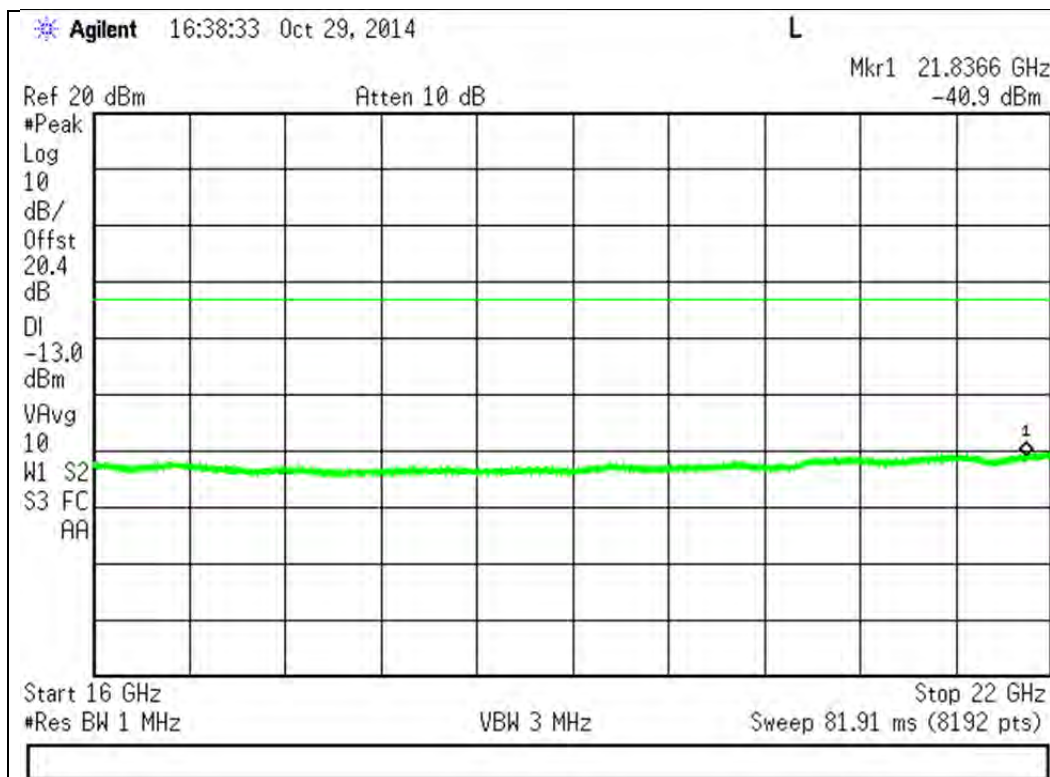
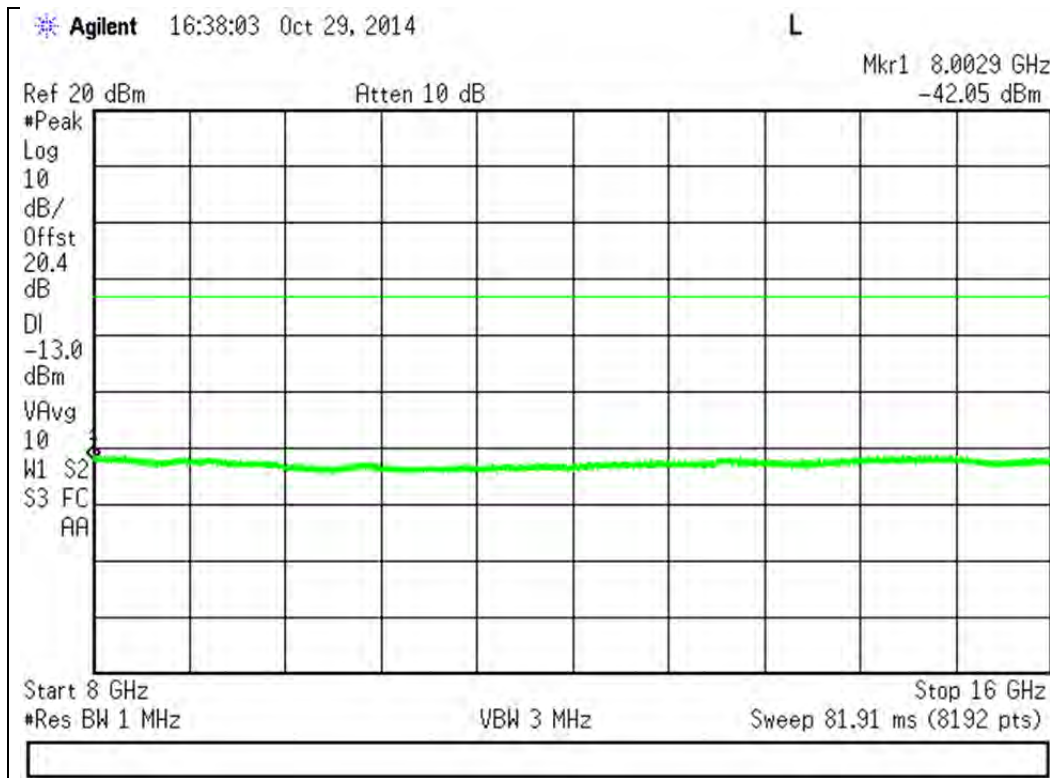

776 – 787 MHz Uplink Test Plots for the

763 - 775 MHz Frequency Range

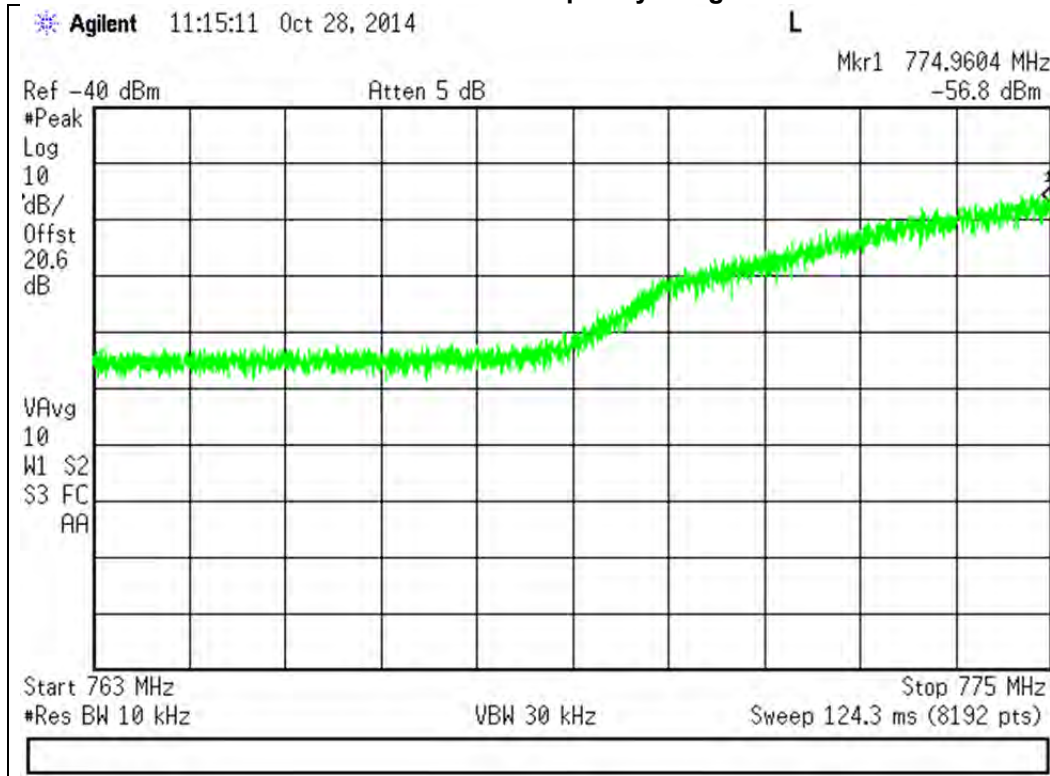

793 - 805 MHz Frequency Range

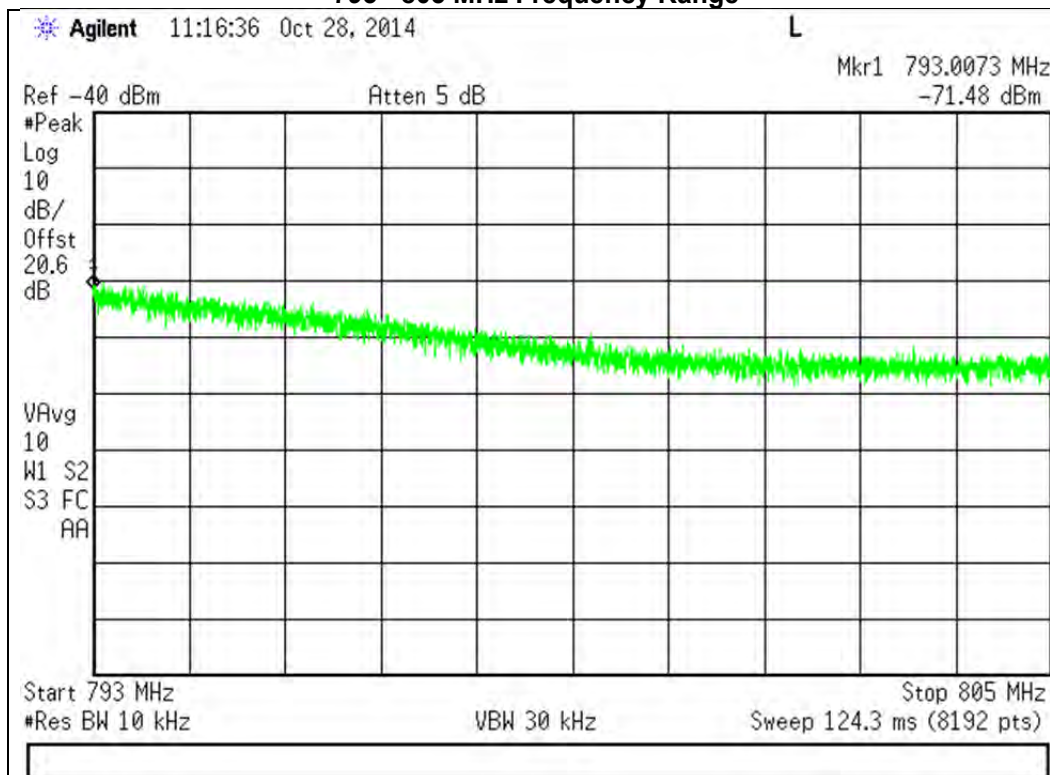

776 – 787 MHz Uplink Test Plots for the

1559 - 1610 MHz Frequency Range (Wideband)

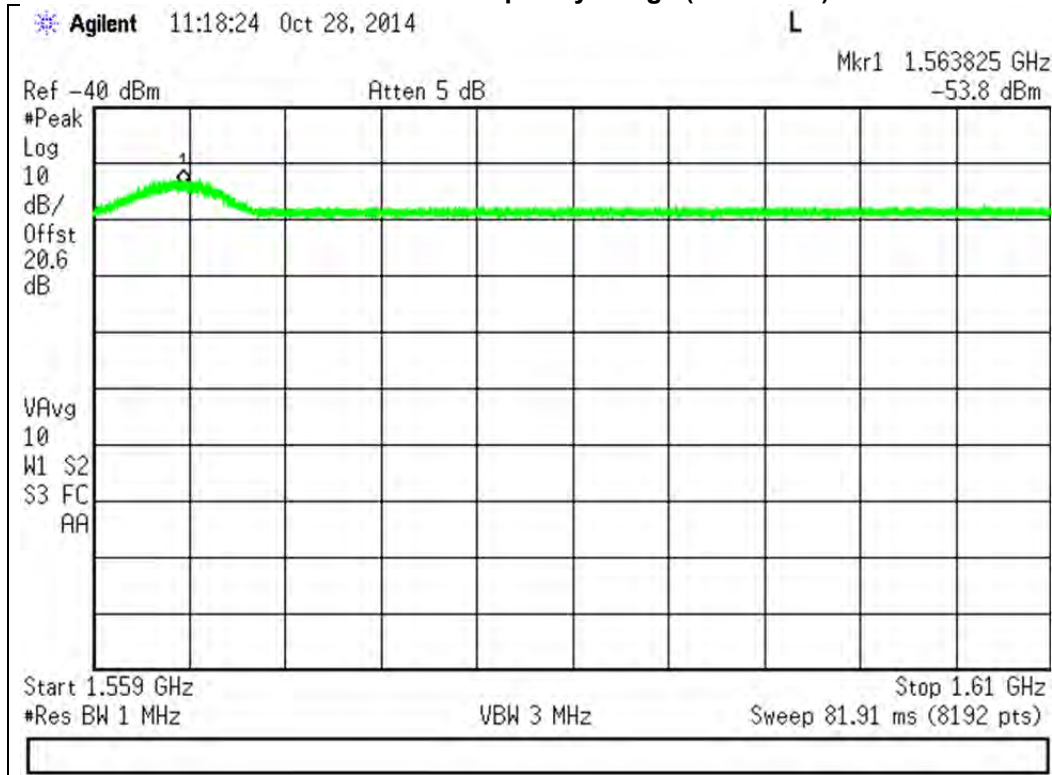

1559 - 1610 MHz Frequency Range (Narrowband)

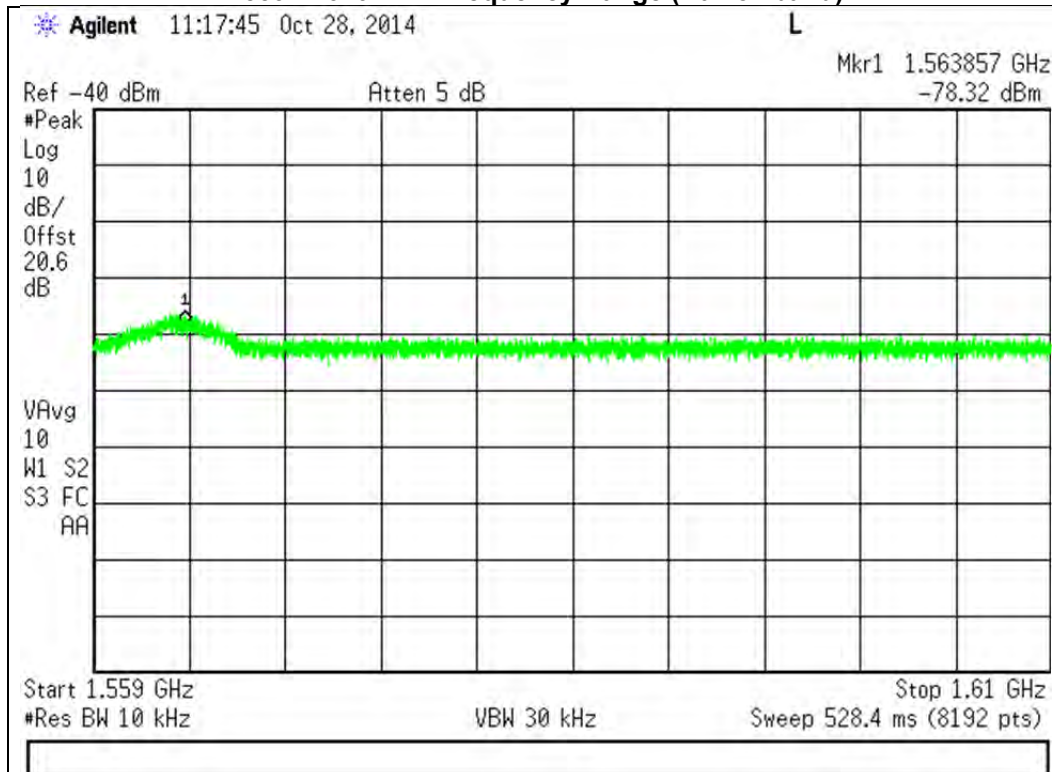

746 – 757 MHz Downlink Test Plots for the

763 - 775 MHz Frequency Range

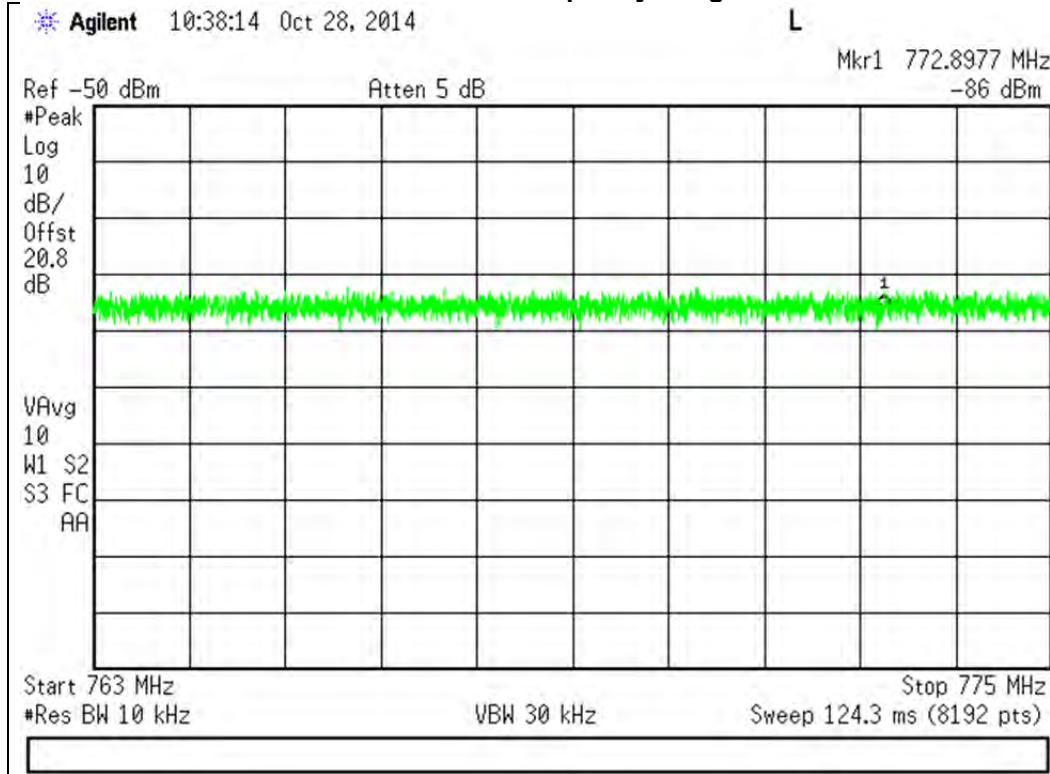

793 - 805 MHz Frequency Range

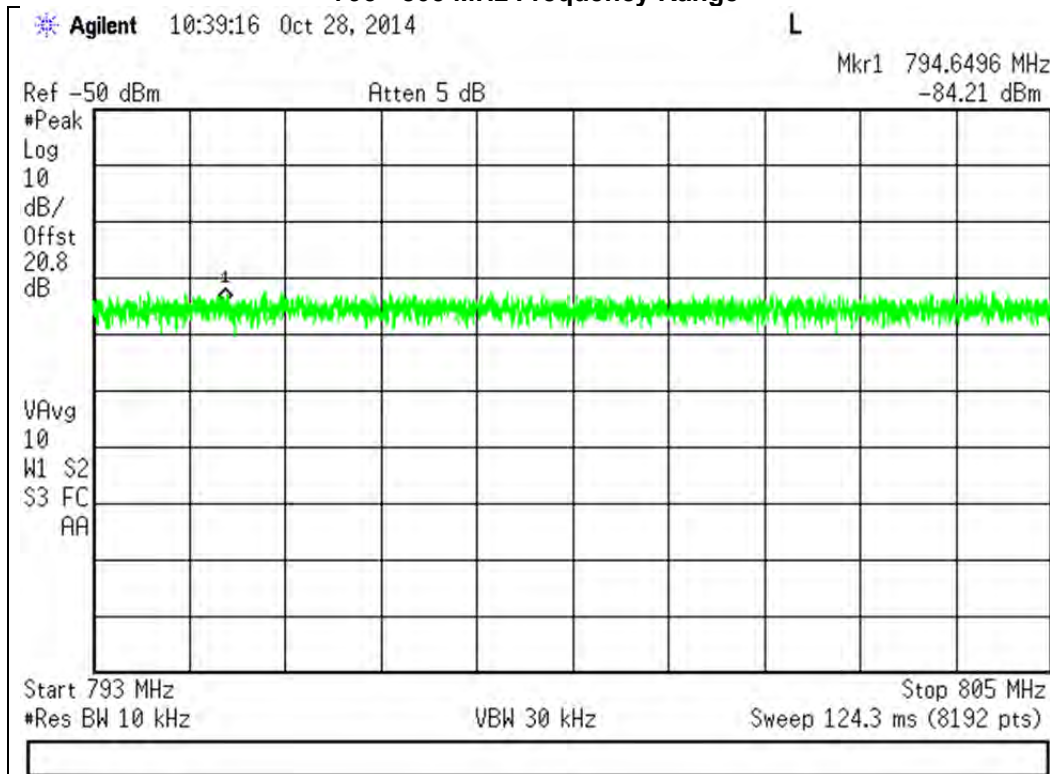

746 – 757 MHz Downlink Test Plots for the

1559 - 1610 MHz Frequency Range (Wideband)

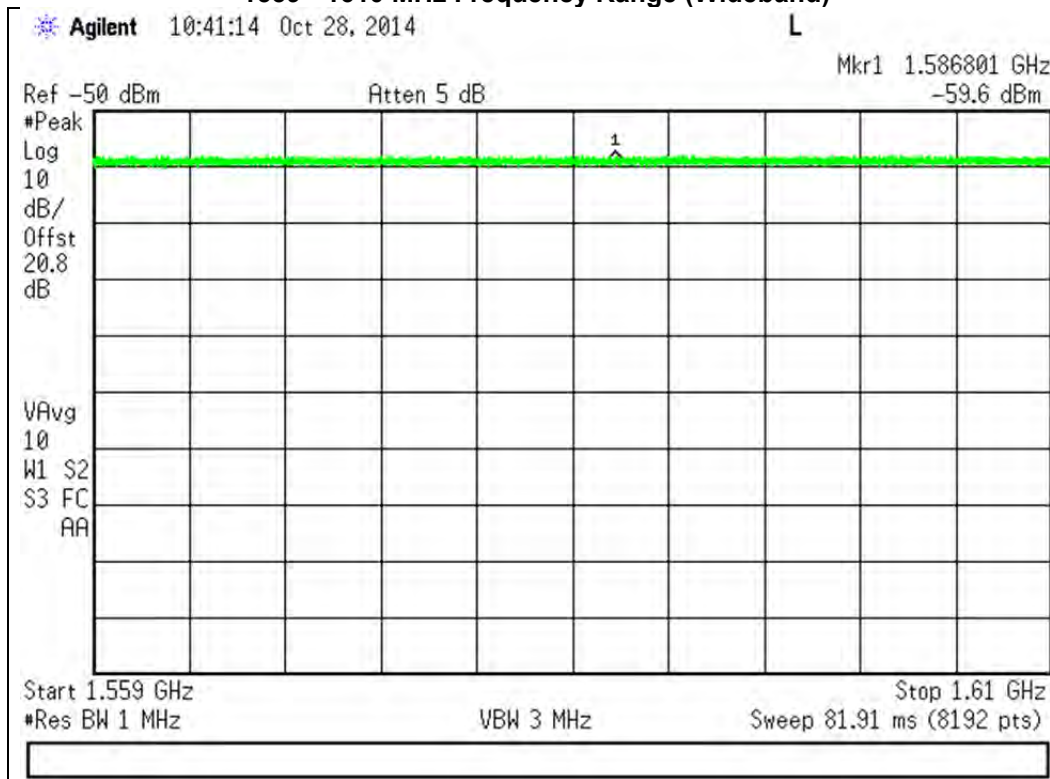

1559 - 1610 MHz Frequency Range (Narrowband)

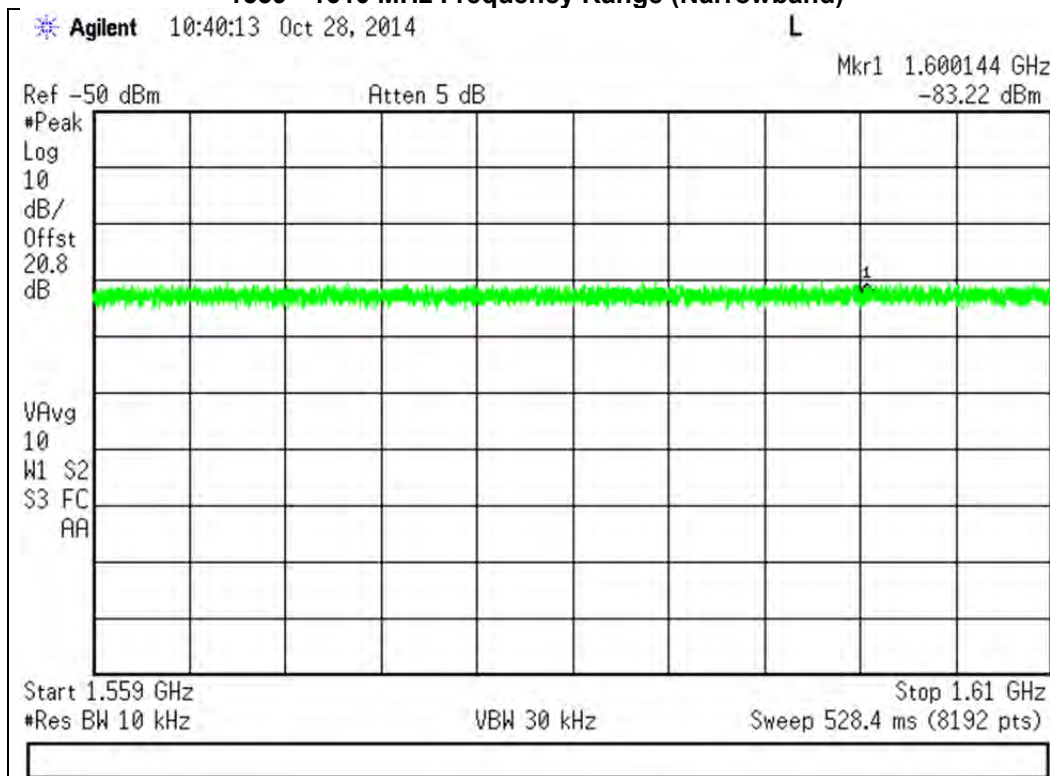

Noise Limits

Engineer: Mike Graffeo

Test Date: 9/26/14

Test Procedure

The EUT was connected to a spectrum analyzer through an attenuator with the losses being input into the spectrum analyzer as a combination of reference level offset and correction factor as necessary to ensure that accurate readings were obtained. A series of tests were performed: the maximum uplink and downlink noise, the variable noise for the uplink and in the presence of a downlink signal, and the variable uplink noise timing. The detailed procedures from KDB 935210 D03 Wideband Consumer Signal Booster Measurement Guidance DR04-41516c were followed.

Noise Limit = $-102.5 + 20 * \text{Log}_{10}(\text{midband of UL})$

Variable Noise = $-103 \text{ dBm/MHz-RSSI}$

Test Setup

Maximum Noise Power

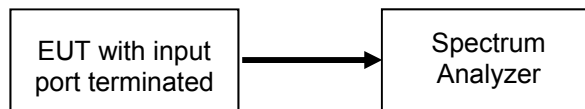

Variable Uplink Noise Power and Timing

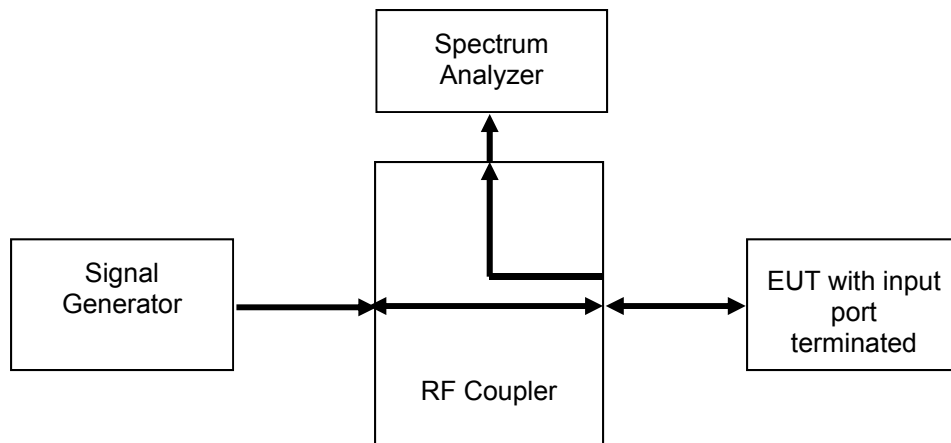

Maximum Uplink Noise Test Results

Frequency Band (MHz)	Measured Noise (dBm)	Limit (dBm)	Margin (dB)	Result
698 - 716	-46.1	-45.5	-0.6	Pass
776 - 787	-45.2	-44.6	-0.6	Pass
824 - 849	-45	-44.1	-0.9	Pass
1710 - 1755	-38.3	-37.7	-0.6	Pass
1850 - 1915	-37.6	-37.0	-0.6	Pass

Maximum Downlink Noise Test Results

Frequency Band (MHz)	Measured Noise (dBm)	Limit (dBm)	Margin (dB)	Result
728 - 746	-46.5	-45.5	-1.0	Pass
746 - 757	-47.7	-44.6	-3.1	Pass
869 - 894	-45.2	-44.1	-1.1	Pass
1930 - 1995	-37.8	-37.0	-0.8	Pass
2110 - 2155	-39	-37.7	-1.3	Pass

Uplink Noise Timing Test Results

Frequency Band (MHz)	Measured Timing (mS)	Limit (mS)	Result
698 - 716	525.00	3000	Pass
776 - 787	543.80	3000	Pass
824 - 849	600.00	3000	Pass
1710 - 1755	675.00	3000	Pass
1850 - 1915	393.70	3000	Pass

Variable Uplink Noise Limit Test Results

698 - 716 MHz

RSSI (dBm)	Noise Limit (dBm)	Measured Noise (dBm)	Margin (dB)
-43.0	-60.0	-65.3	-5.3
-42.0	-61.0	-65.6	-4.6
-64.0	-45.5	-47.7	-2.2
-62.0	-45.5	-47.6	-2.1
-65.0	-45.5	-47.5	-2.0
-66.0	-45.5	-47.5	-2.0

776 - 787 MHz

RSSI (dBm)	Noise Limit (dBm)	Measured Noise (dBm)	Margin (dB)
-44.0	-59.0	-60.6	-1.6
-43.0	-60.0	-61.1	-1.1
-70.0	-44.6	-45.7	-1.1
-69.0	-44.6	-45.7	-1.1
-68.0	-44.6	-45.7	-1.1
-67.0	-44.6	-45.7	-1.1

824 - 849 MHz

RSSI (dBm)	Noise Limit (dBm)	Measured Noise (dBm)	Margin (dB)
-44.0	-59.0	-62.6	-3.6
-43.0	-60.0	-63.0	-3.0
-70.0	-44.0	-45.1	-1.1
-69.0	-44.0	-45.1	-1.1
-68.0	-44.0	-45.1	-1.1
-67.0	-44.0	-45.1	-1.1

1710 - 1755 MHz

RSSI (dBm)	Noise Limit (dBm)	Measured Noise (dBm)	Margin (dB)
-80.0	-37.7	-39.8	-2.1
-79.0	-37.7	-39.8	-2.1
-78.0	-37.7	-39.8	-2.1
-77.0	-37.7	-39.8	-2.1
-54.0	-49.0	-50.6	-1.6
-56.0	-47.0	-48.6	-1.6

1850 - 1915 MHz

RSSI (dBm)	Noise Limit (dBm)	Measured Noise (dBm)	Margin (dB)
-46.0	-57.0	-58.9	-1.9
-45.0	-58.0	-59.3	-1.3
-80.0	-37.0	-38.2	-1.2
-79.0	-37.0	-38.2	-1.2
-78.0	-37.0	-38.2	-1.2
-77.0	-37.0	-38.2	-1.2

Maximum Uplink Noise Test Plots

698 - 716 MHz Band

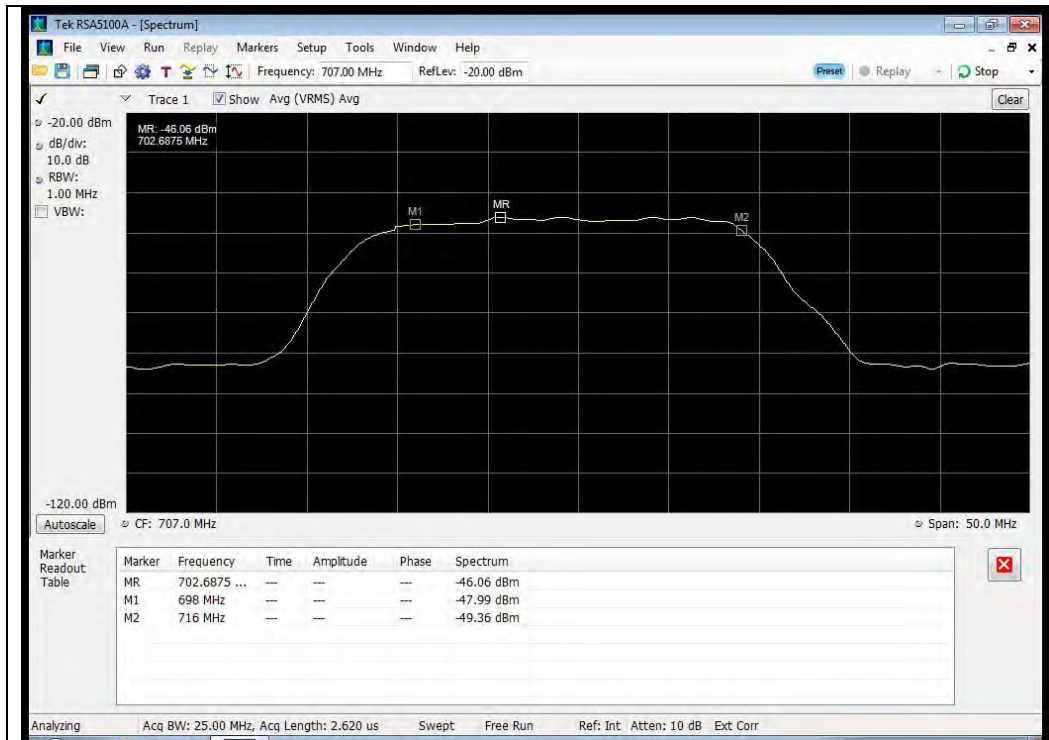

776 - 787 MHz Band

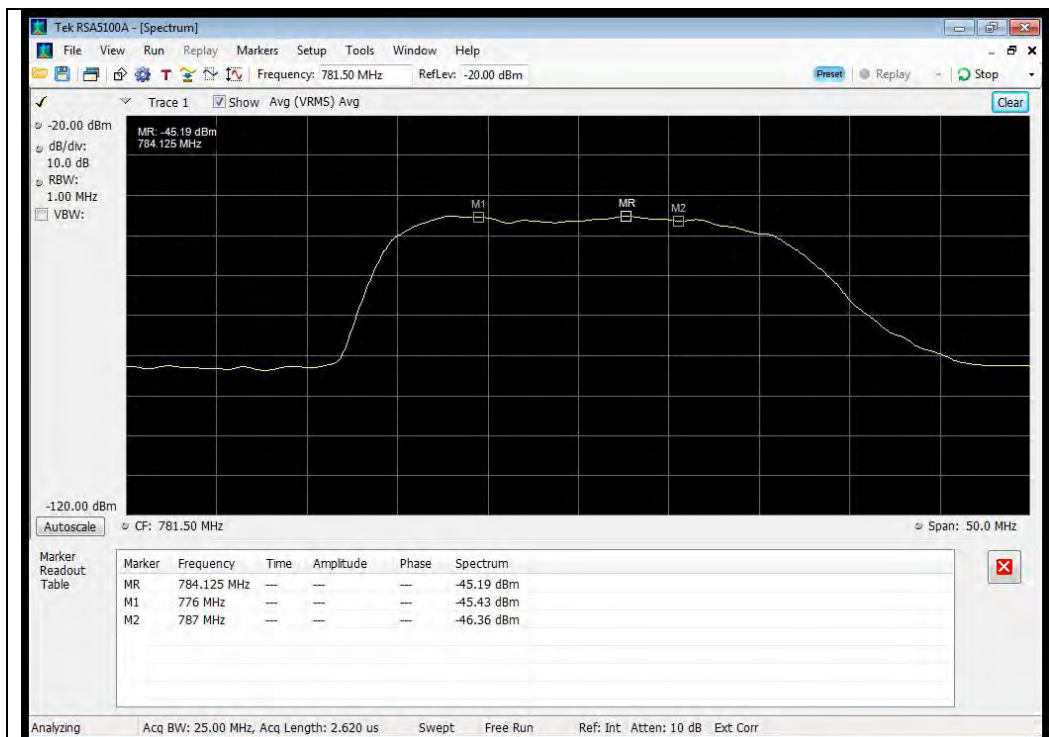

824 - 849 MHz Band

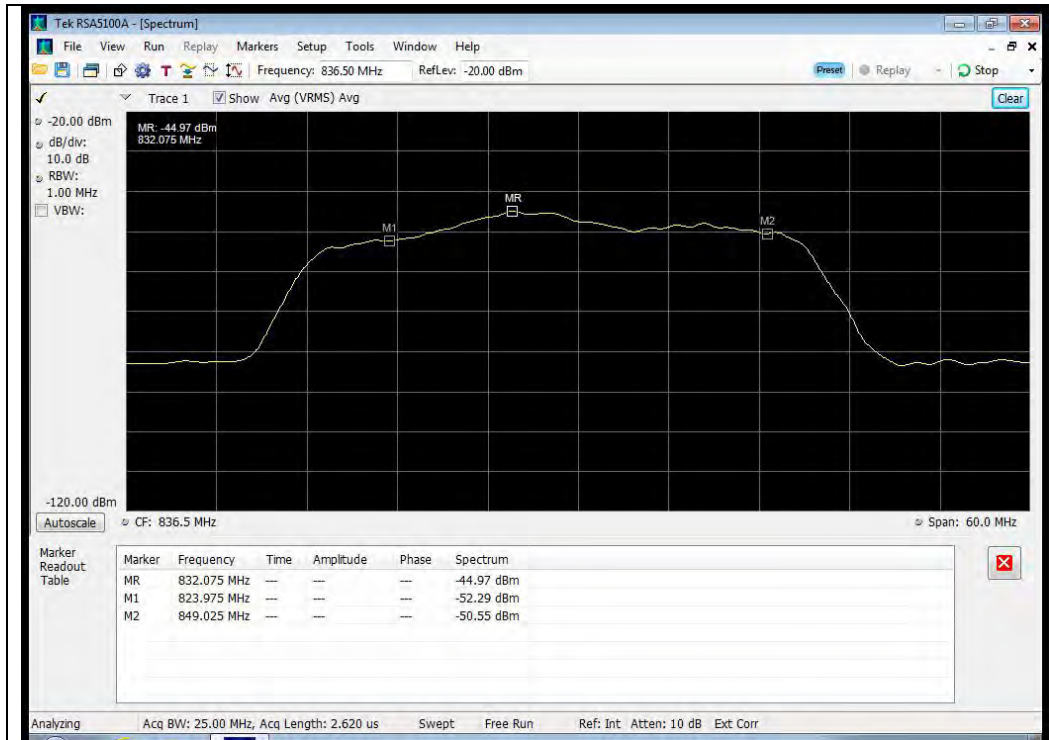

1710 - 1755 MHz Band

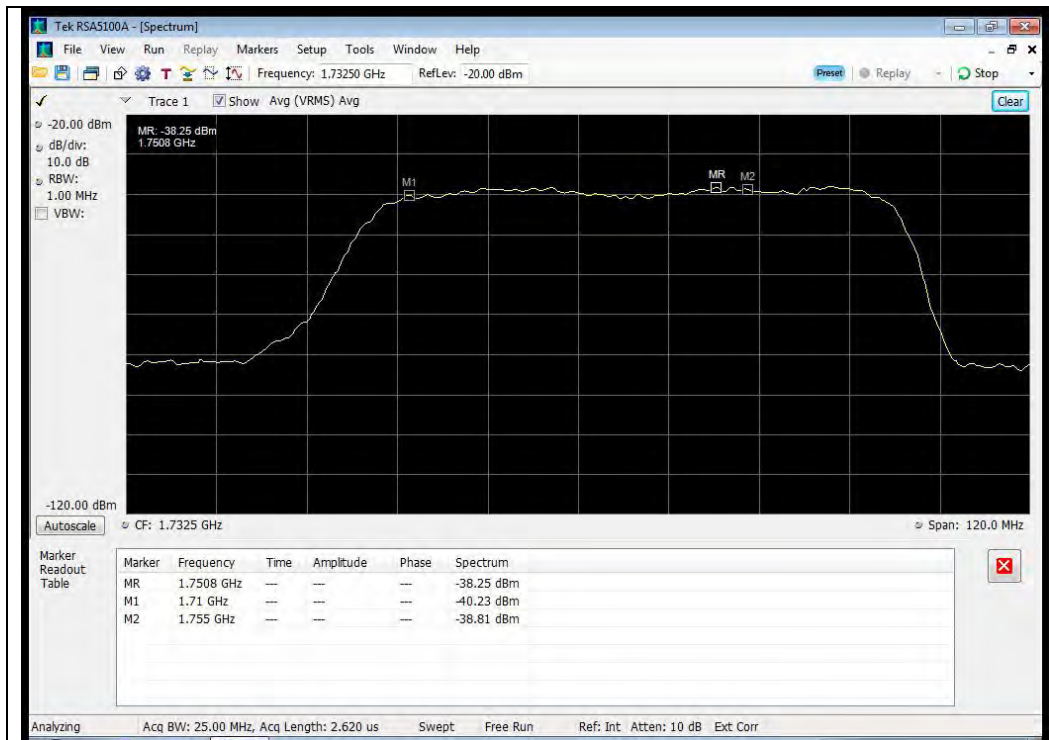

1850 - 1915 MHz Band

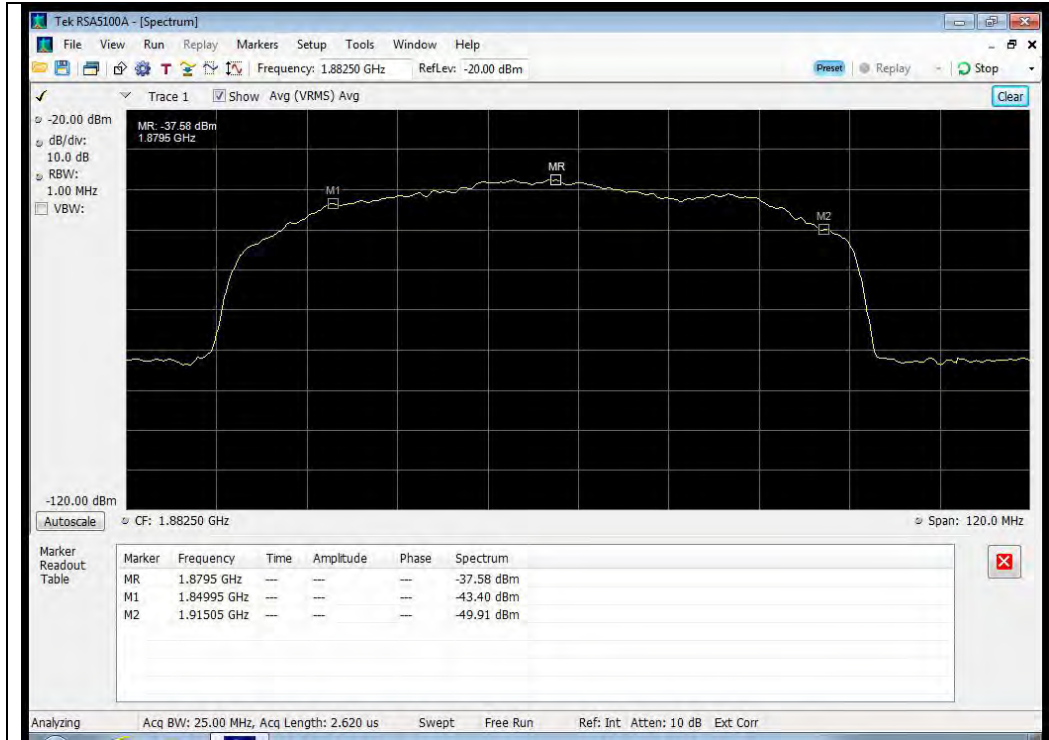

Maximum Downlink Noise Test Plots

728 - 746 MHz Band

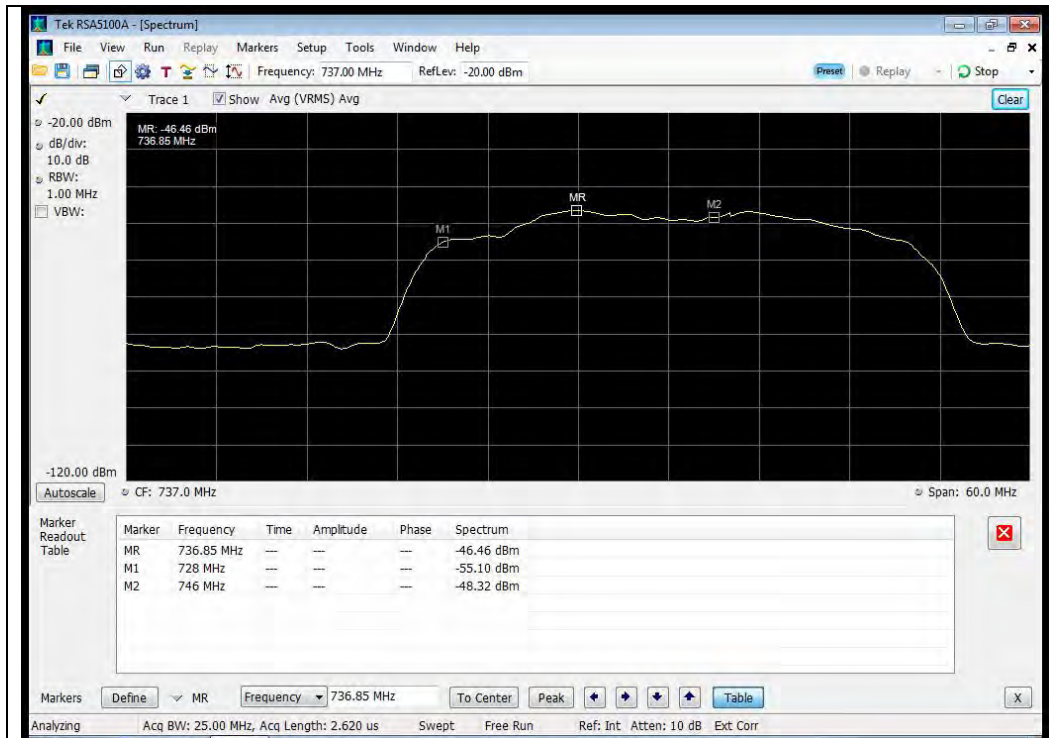

746 - 757 MHz Band

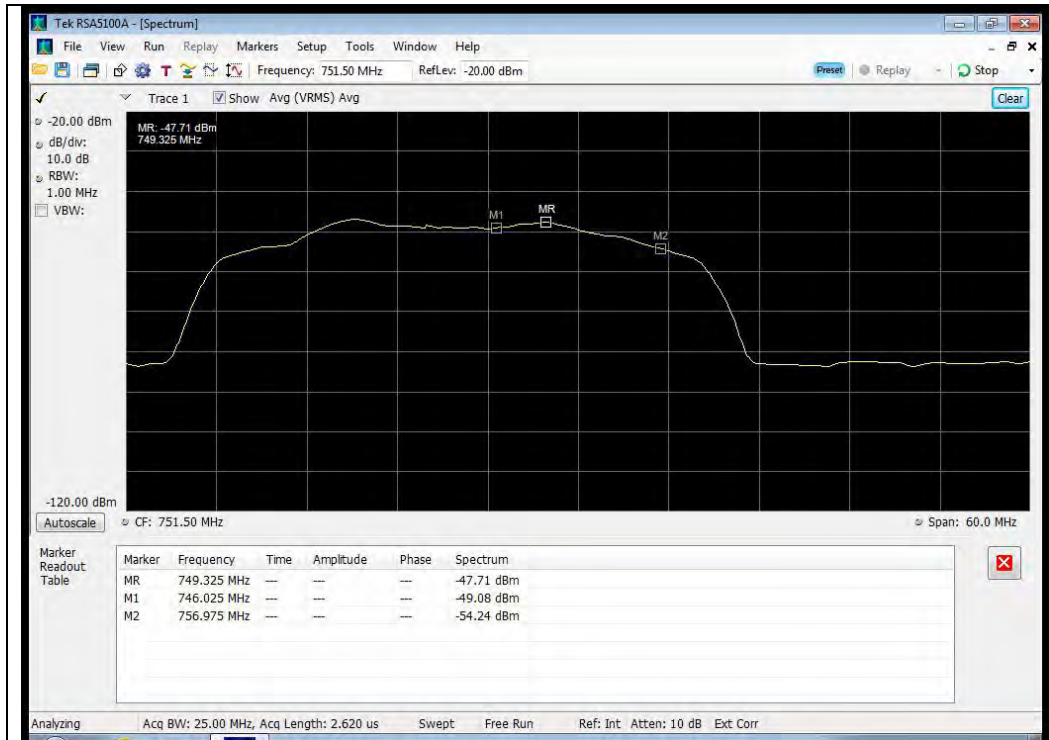

869 - 894 MHz Band

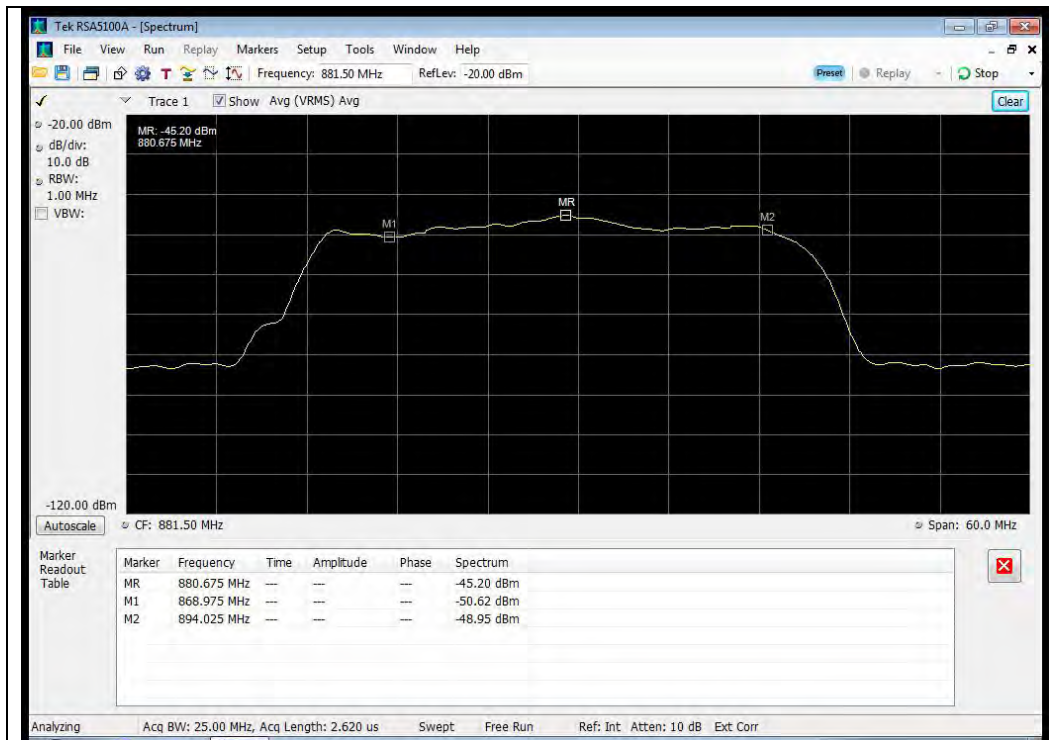

1930 - 1995 MHz Band

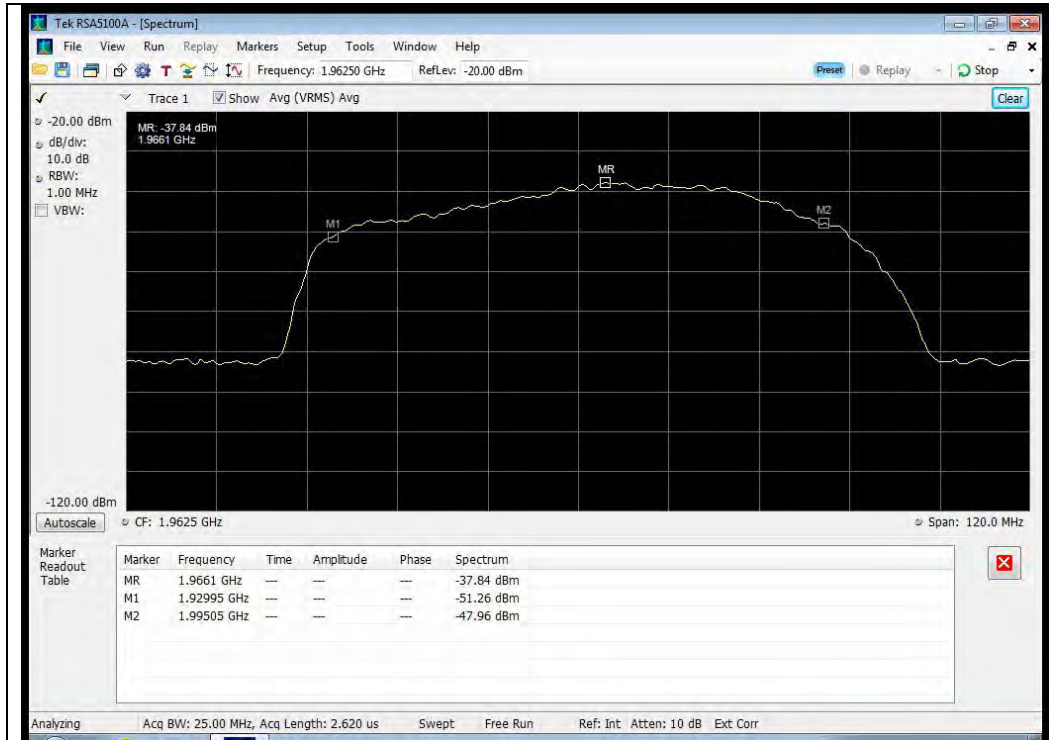

2110 - 2155 MHz Band

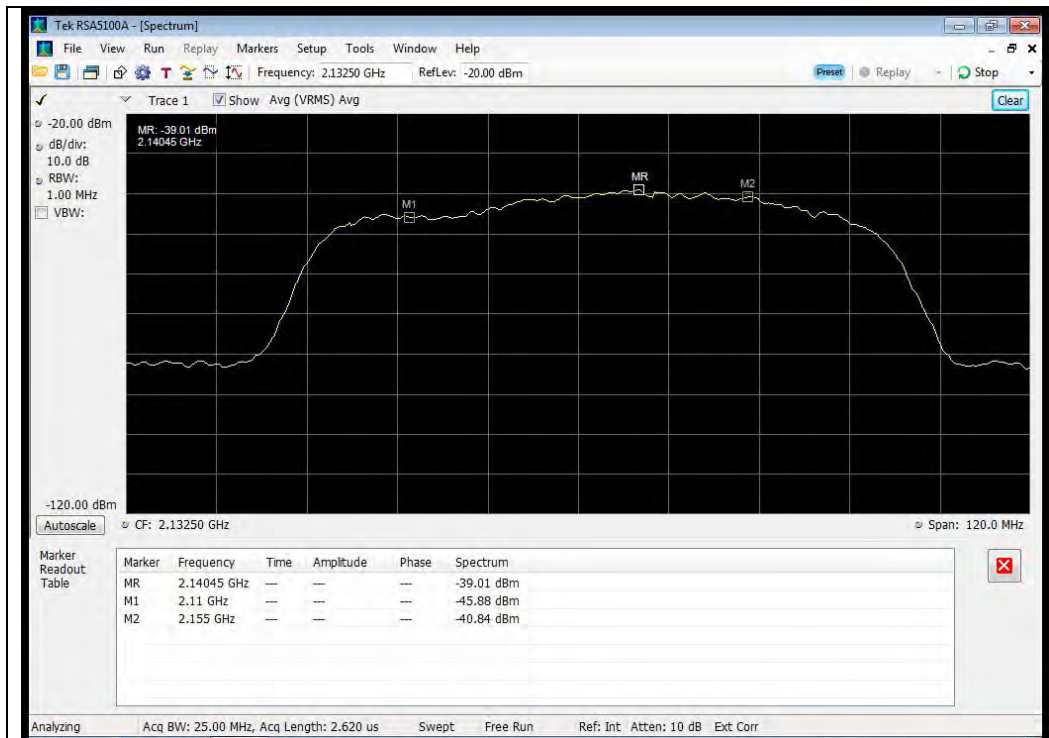

Uplink Noise Timing Test Plots

698 - 716 MHz Band

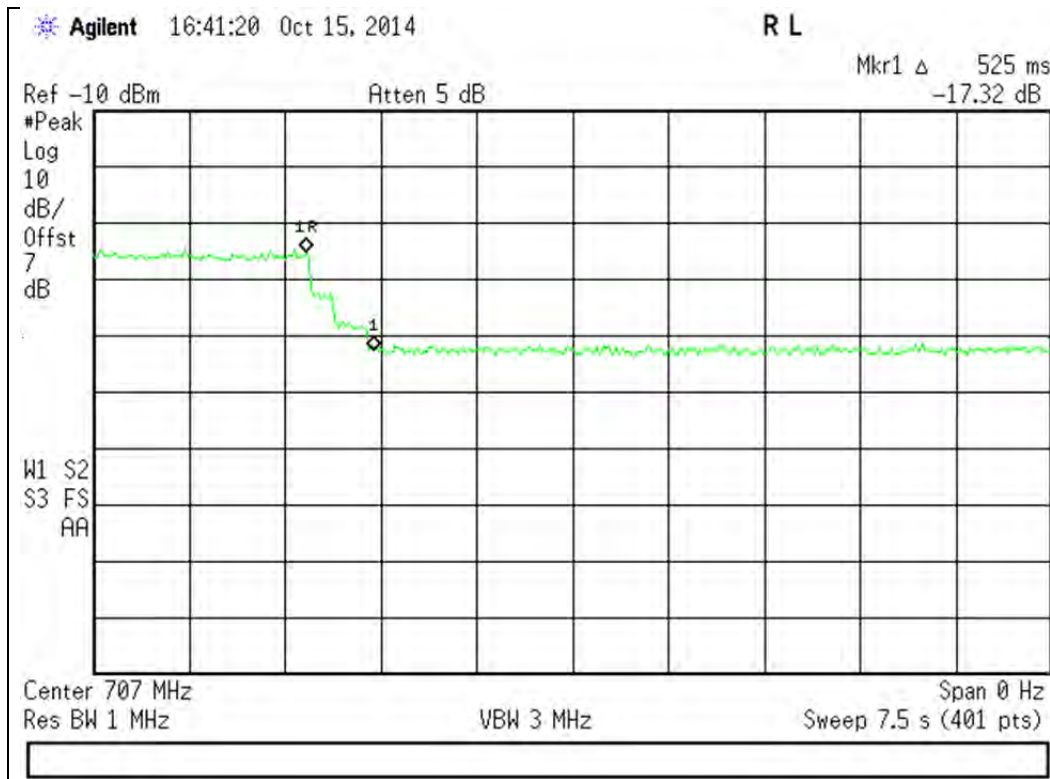

776 - 787 MHz Band

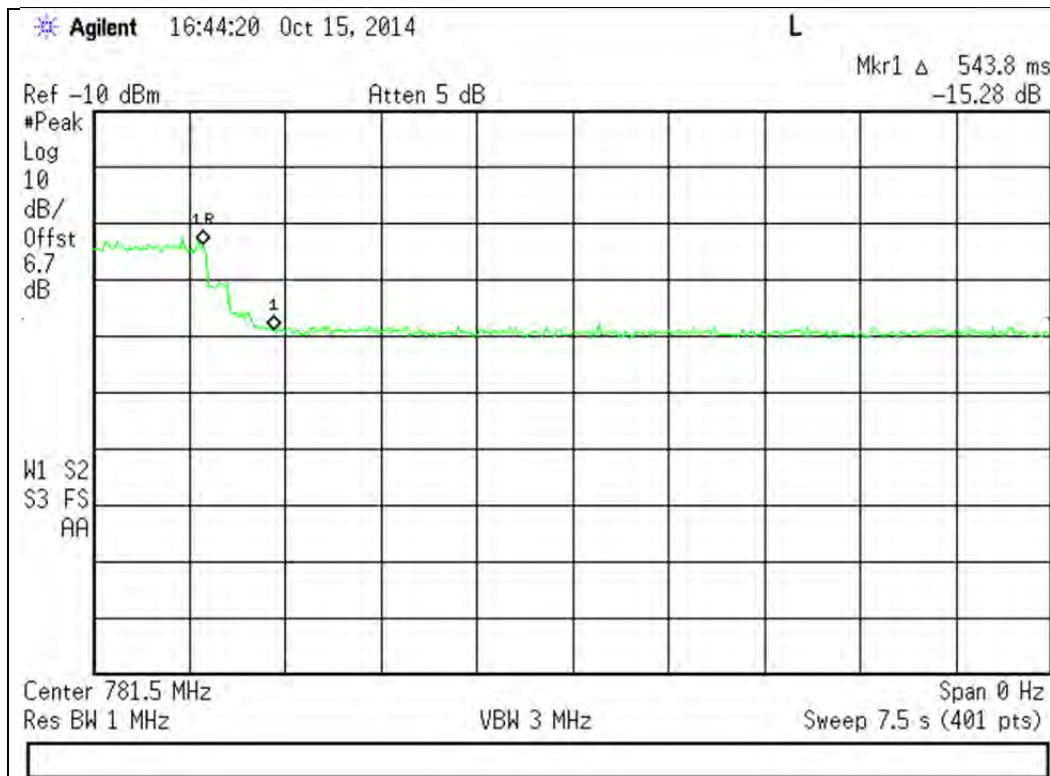

824 - 849 MHz Band

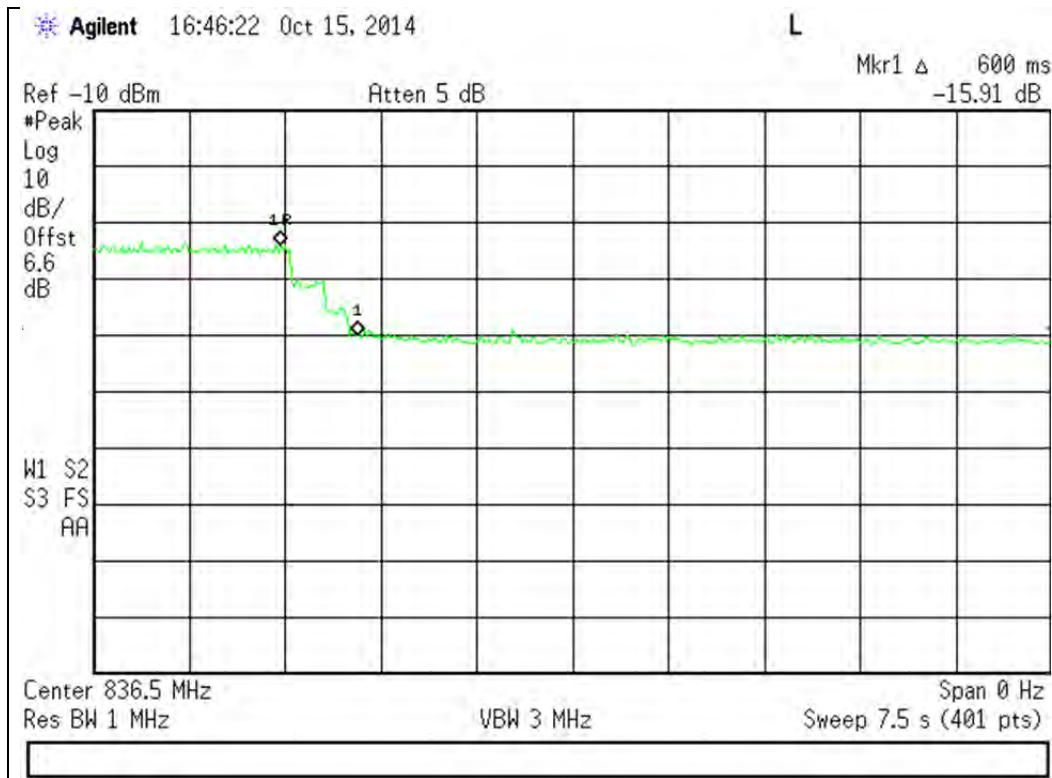

1710 - 1755 MHz Band

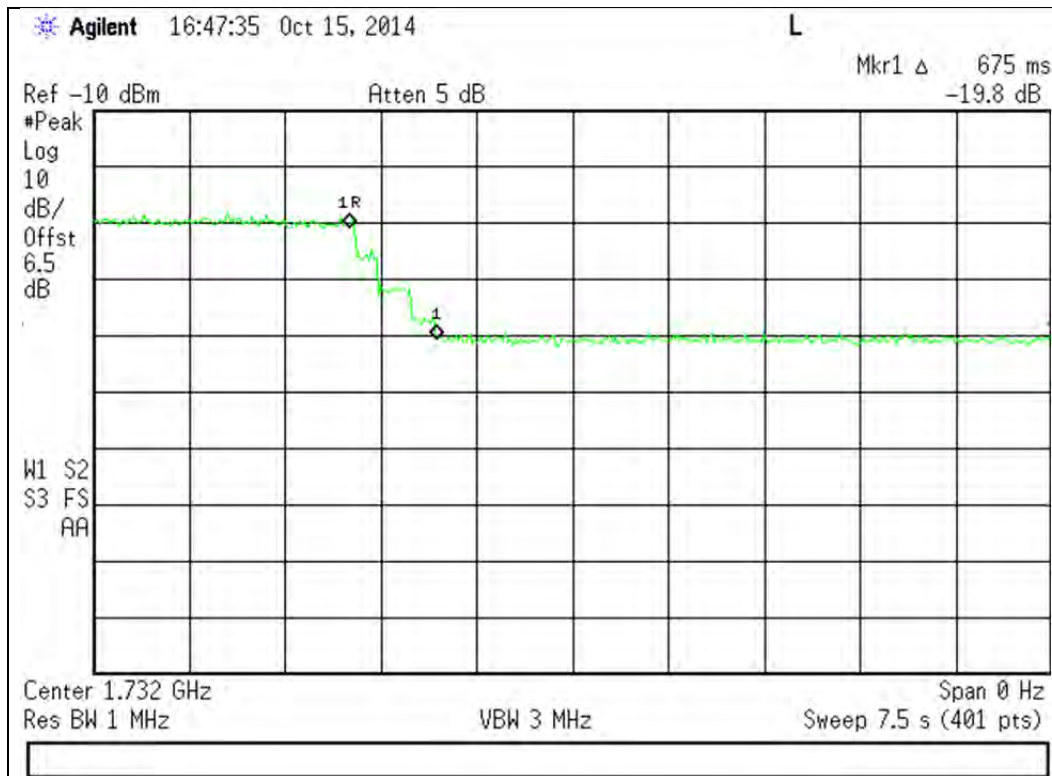

1850 - 1915 MHz Band

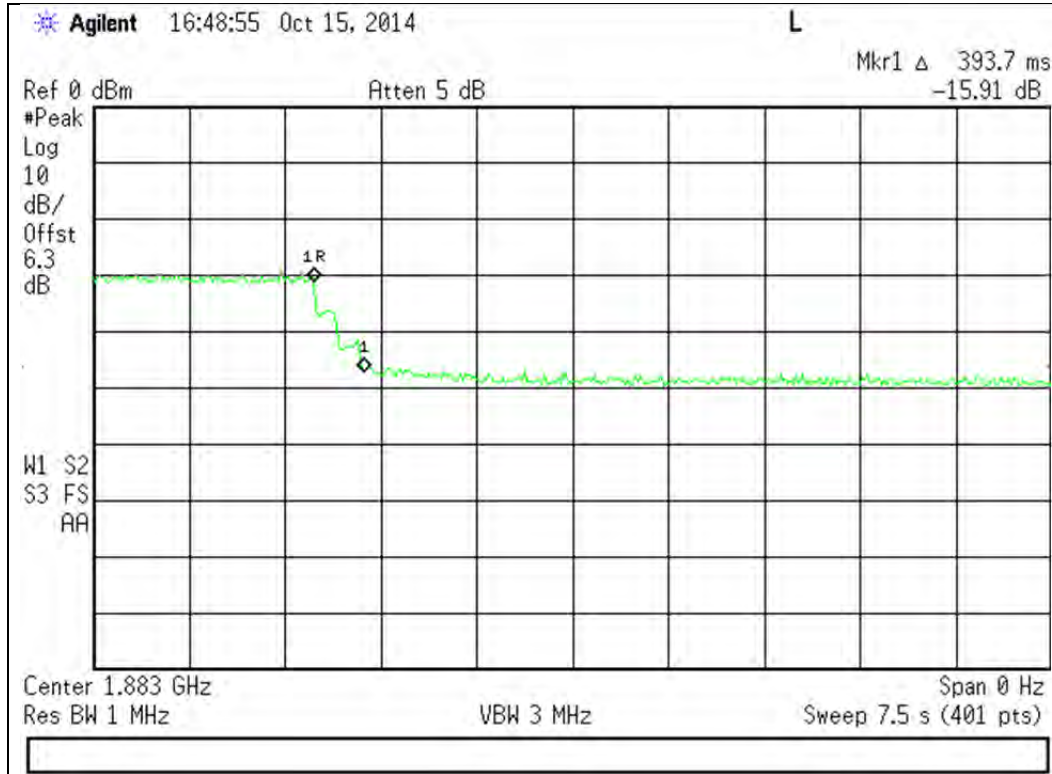

Uplink Inactivity

Engineer: Mike Graffeo

Test Date: 10/3/14

Test Procedure

The EUT was connected directly to a spectrum analyzer set to operate in the center of the EUT operational uplink and downlink bands. The span was set to 0 Hz with a sweep time of 330 seconds and MAX HOLD operation. The EUT was powered on and the time for the uplink to return to an inactive state was measured using the DELTA MARKER method to ensure that it was less than 300 seconds. The noise level after the return to an inactive state was less than -70 dBm/MHz

Test Setup

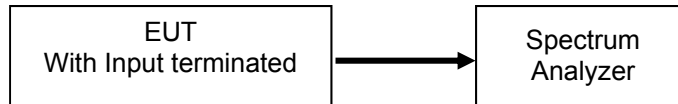

Uplink Test Results

Frequency Band (MHz)	Measured Time (Seconds)	Limit (Seconds)	Result
698 - 716	280.5	300	Pass
776 - 787	280.5	300	Pass
824 - 849	281.3	300	Pass
1710 - 1755	279.7	300	Pass
1850 - 1915	281.3	300	Pass

Uplink Inactivity Test Results

698 - 716 MHz

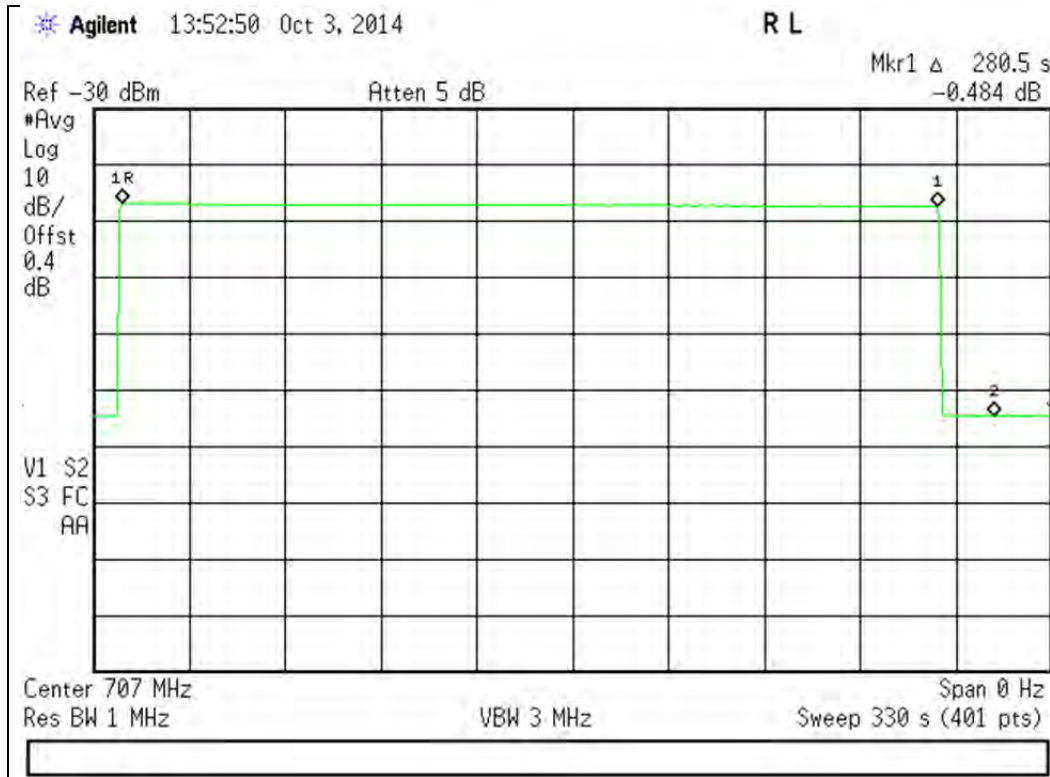

776 - 787 MHz

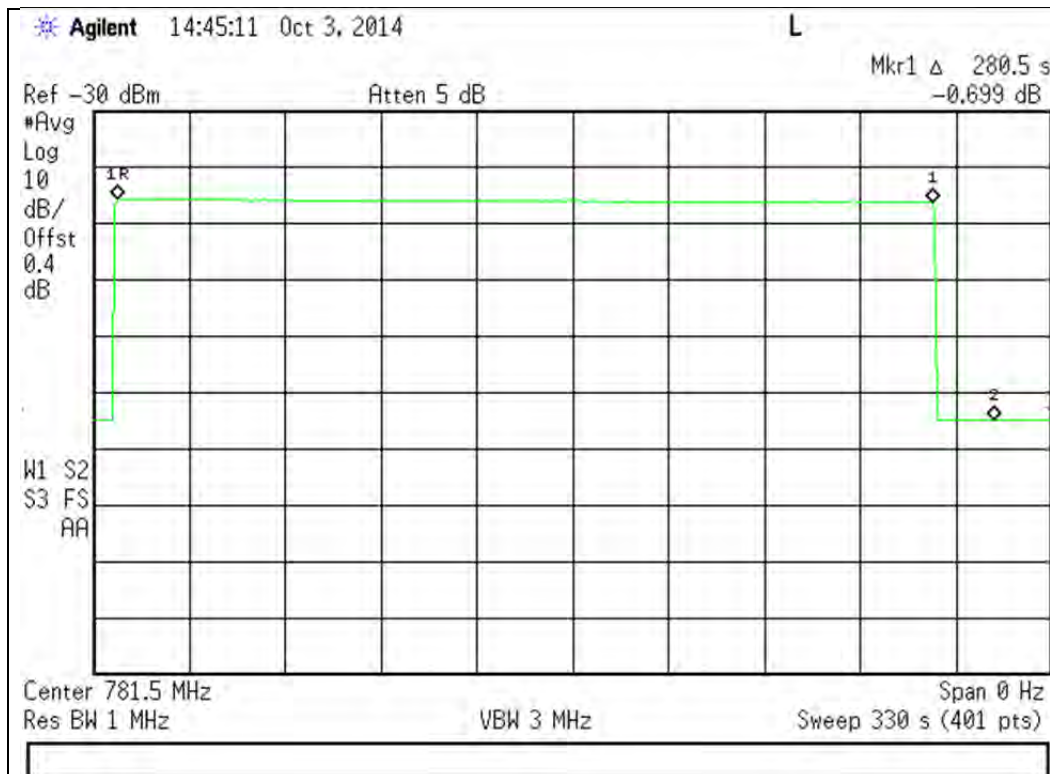

824 - 849 MHz

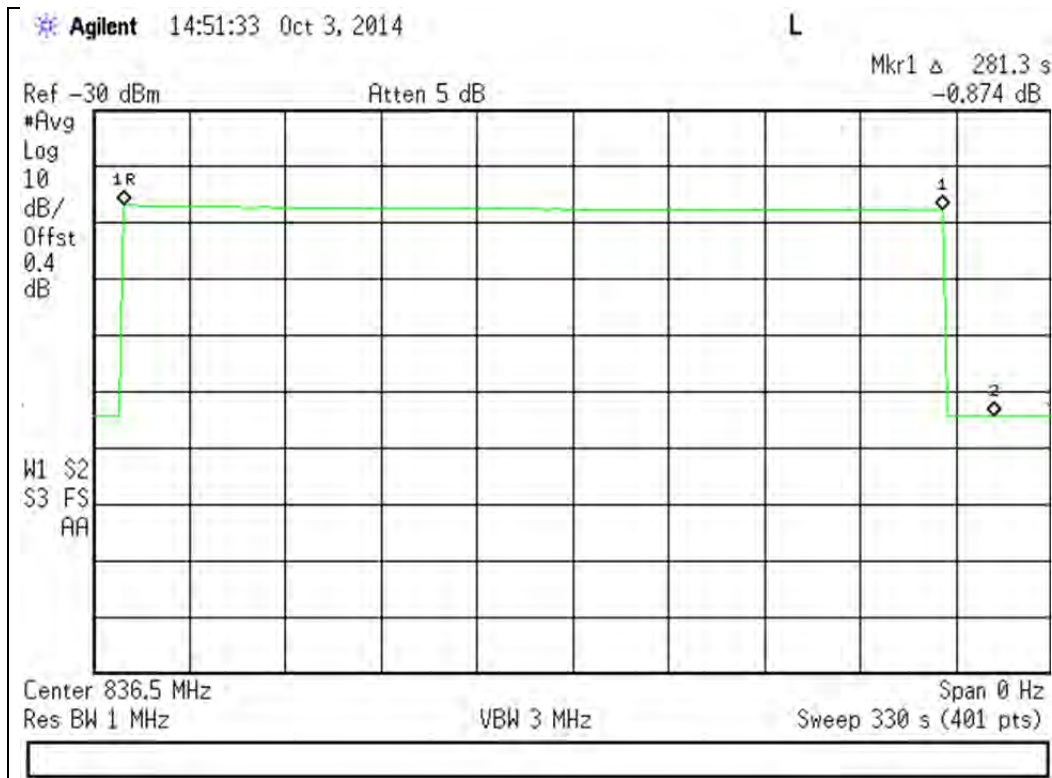

1710 - 1755 MHz

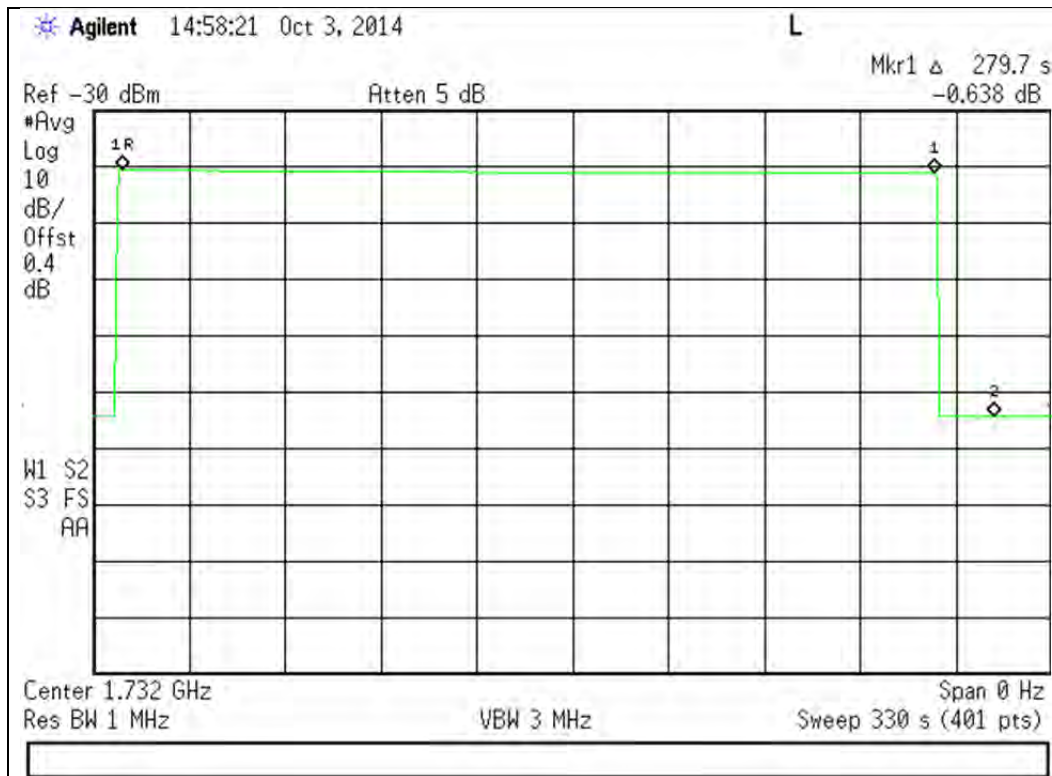

1850 - 1915 MHz

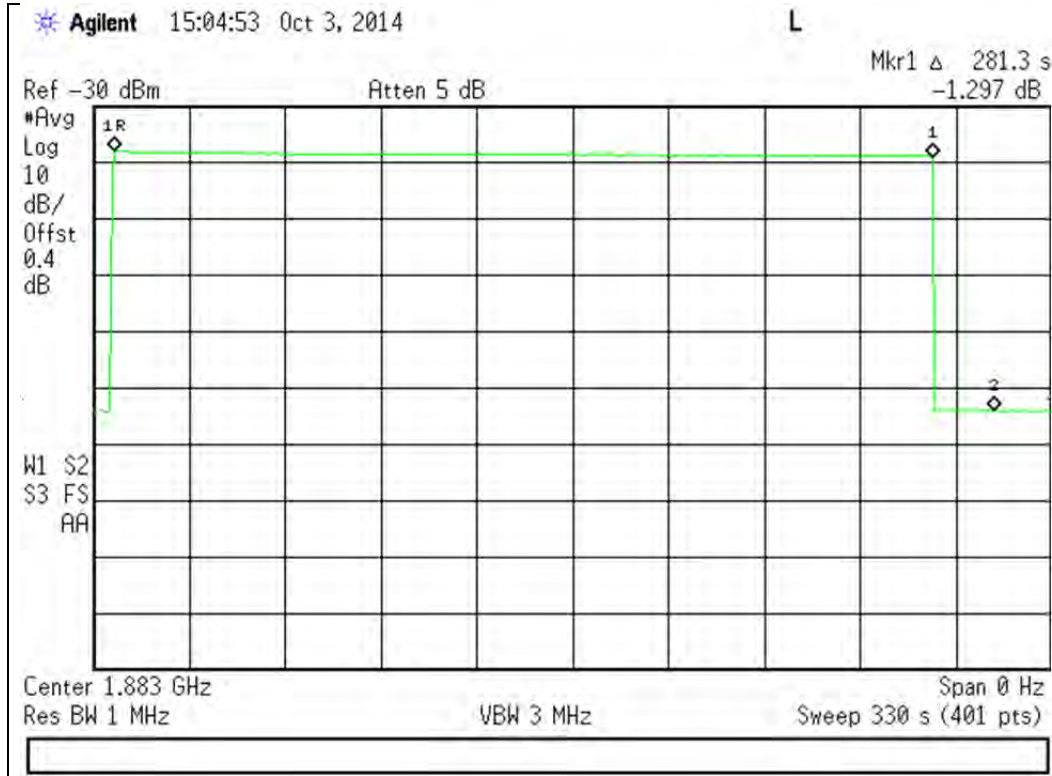

Variable Gain

Engineer: Mike Graffeo

Test Date: 9/25/14

Test Procedure

The EUT was connected to a spectrum analyzer through an attenuator with the losses being input into the spectrum analyzer as a combination of reference level offset and correction factor in order to ensure accurate readings were obtained. The uplink gain in the presence of a downlink signal was measured for each operational uplink band using the detailed procedures from KDB 935210 D03 Wideband Consumer Signal Booster Measurement Guidance DR04-41516.

The following formula is used for calculating the limits:

$$\text{Variable Gain} = -34 \text{ dB} - \text{RSSI} + \text{MSCL}$$

$$\text{Fixed booster maximum gain} = 6.5 \text{ dB} + 20 * \text{Log}_{10}(\text{midband of UL})$$

(Fixed booster maximum gain is same for Downlink as for Uplink.)

Test Setup

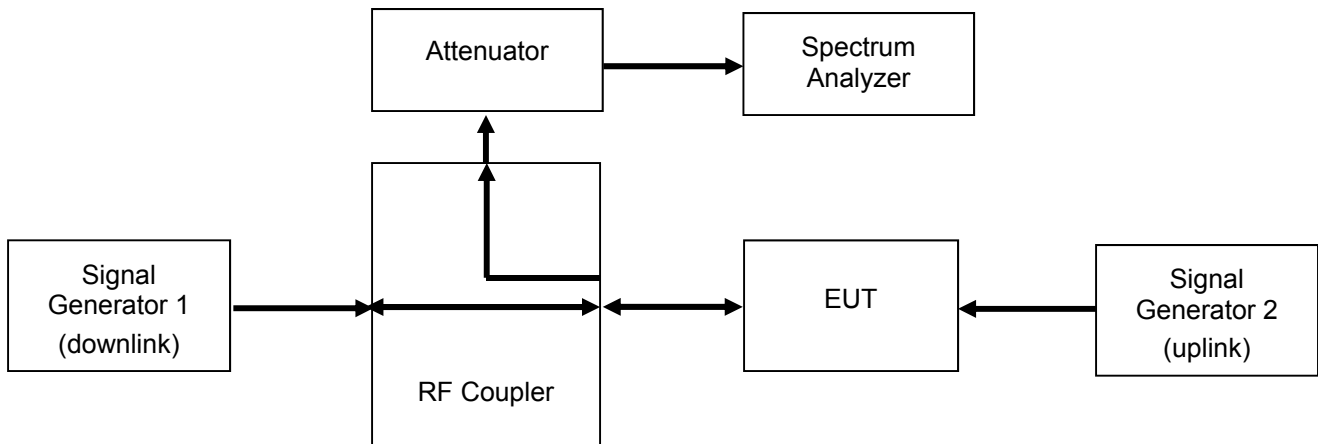

Uplink Test Results

698 - 716 MHz

RSSI (dBm)	MSCL (dB)	Gain Limit (dBm)	P(in) (dBm)	P(out) (dBm)	Gain (dB)	Margin (dB)
-69.0	35.6	63.5	-46.4	17.0	63.4	-0.1
-68.0	35.6	63.5	-46.4	17.0	63.4	-0.1
-67.0	35.6	63.5	-46.4	17.0	63.4	-0.1
-66.0	35.6	63.5	-46.4	17.0	63.4	-0.1
-50	35.6	51.6	-46.4	3.4	49.8	-1.8
-49	35.6	50.6	-46.4	2.4	48.8	-1.8

776 - 787 MHz

RSSI (dBm)	MSCL (dB)	Gain Limit (dBm)	P(in) (dBm)	P(out) (dBm)	Gain (dB)	Margin (dB)
-51.0	36.4	53.4	-44.8	8.1	52.9	-0.5
-50.0	36.4	52.4	-44.8	7.1	51.9	-0.5
-69.0	36.4	64.0	-44.8	17.0	61.8	-2.2
-68.0	36.4	64.0	-44.8	17.0	61.8	-2.2
-67.0	36.4	64.0	-44.8	17.0	61.8	-2.2
-66.0	36.4	64.0	-44.8	17.0	61.8	-2.2

824 - 849 MHz

RSSI (dBm)	MSCL (dB)	Gain Limit (dBm)	P(in) (dBm)	P(out) (dBm)	Gain (dB)	Margin (dB)
-73.0	37.0	65.0	-42.6	20.0	62.6	-2.4
-72.0	37.0	65.0	-42.6	20.0	62.6	-2.4
-71.0	37.0	65.0	-42.6	20.0	62.6	-2.4
-70.0	37.0	65.0	-42.6	20.0	62.6	-2.4
-52	37.0	55.0	-42.6	8.2	50.8	-4.2
-51	37.0	54.0	-42.6	7.2	49.8	-4.2

1710 - 1755 MHz

RSSI (dBm)	MSCL (dB)	Gain Limit (dBm)	P(in) (dBm)	P(out) (dBm)	Gain (dB)	Margin (dB)
-46	40.4	52.4	-44.6	-1.5	43.1	-9.3
-73.0	40.4	71.0	-44.6	17.0	61.6	-9.4
-72.0	40.4	71.0	-44.6	17.0	61.6	-9.4
-71.0	40.4	71.0	-44.6	17.0	61.6	-9.4
-70.0	40.4	71.0	-44.6	17.0	61.6	-9.4
-47	40.4	53.4	-44.6	-0.7	43.9	-9.5

1850 - 1915 MHz

RSSI (dBm)	MSCL (dB)	Gain Limit (dBm)	P(in) (dBm)	P(out) (dBm)	Gain (dB)	Margin (dB)
-78.0	38.7	72.0	-50.0	17.0	67.0	-5.0
-77.0	38.7	72.0	-50.0	17.0	67.0	-5.0
-76.0	38.7	72.0	-50.0	17.0	67.0	-5.0
-75.0	38.7	72.0	-50.0	17.0	67.0	-5.0
-65	38.7	69.7	-50.0	13.2	63.2	-6.5
-64	38.7	68.7	-50.0	12.1	62.1	-6.6

Uplink Gain Timing Test Results

Frequency Band (MHz)	Measured Timing (milliseconds)	Limit (milliseconds)	Result
698 - 716	451.30	3000	Pass
776 - 787	381.30	3000	Pass
824 - 849	643.20	3000	Pass
1710 - 1755	395.30	3000	Pass
1850 - 1915	635.50	3000	Pass

Uplink Gain Timing Test Plot 698 – 716 MHz

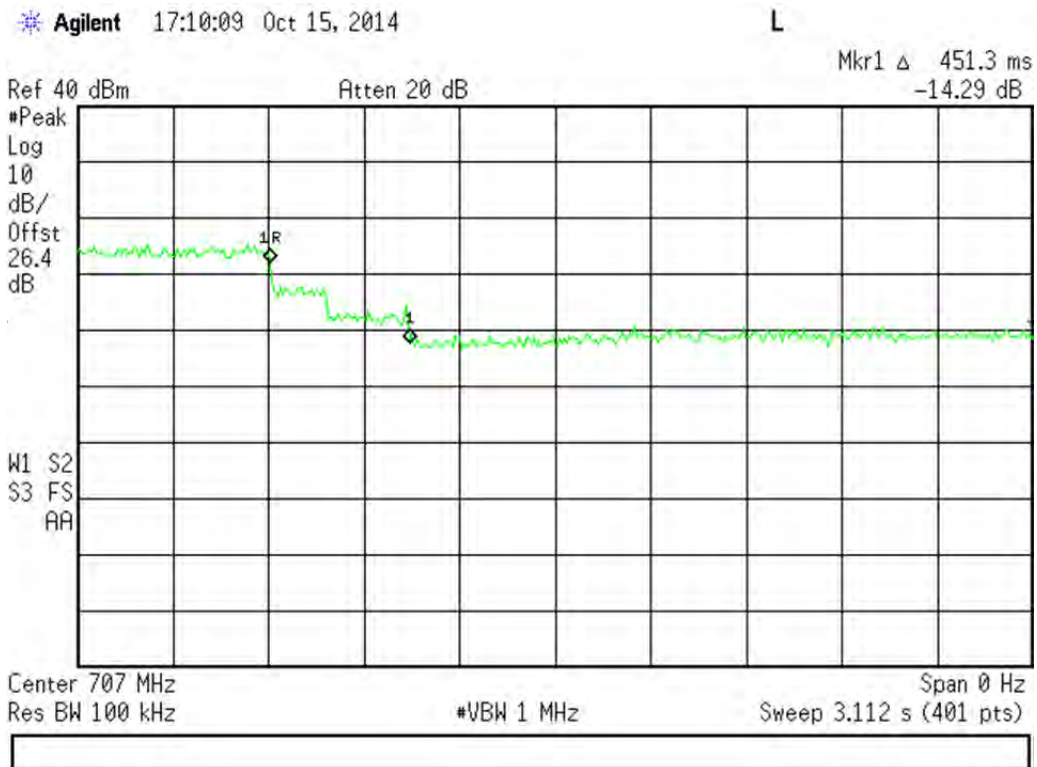

Uplink Gain Timing Test Plot 776 - 787 MHz

Agilent 17:20:17 Oct 15, 2014

L

Mkr1 Δ 381.3 ms
-14.3 dB

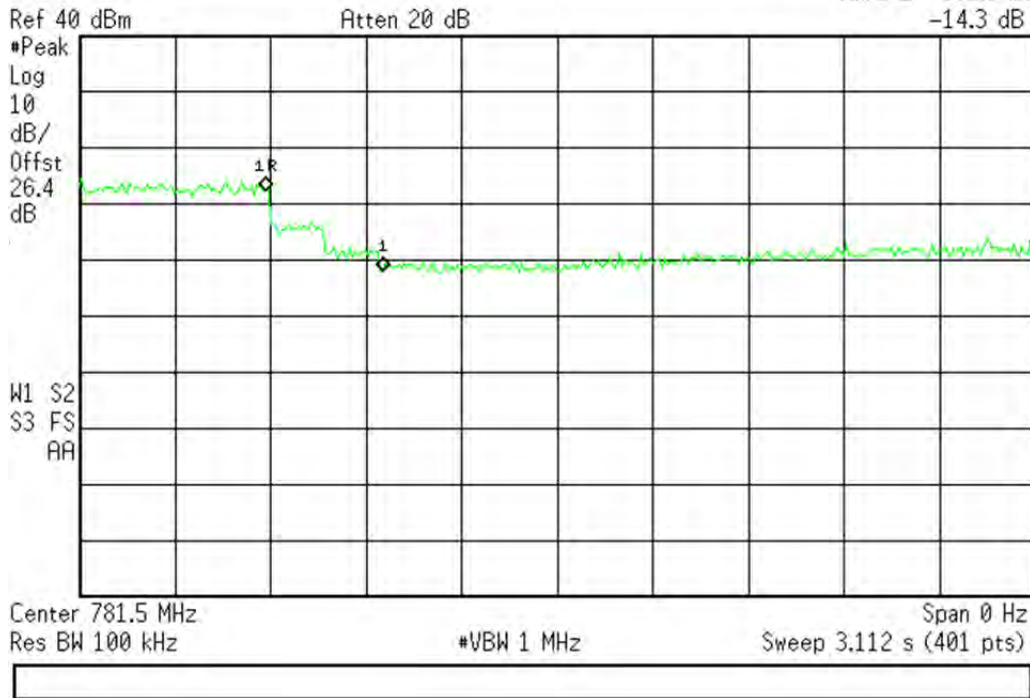

Uplink Gain Timing Test Plot 824 - 849 MHz

Agilent 17:27:12 Oct 15, 2014

L

Mkr1 Δ 643.2 ms
-18.09 dB

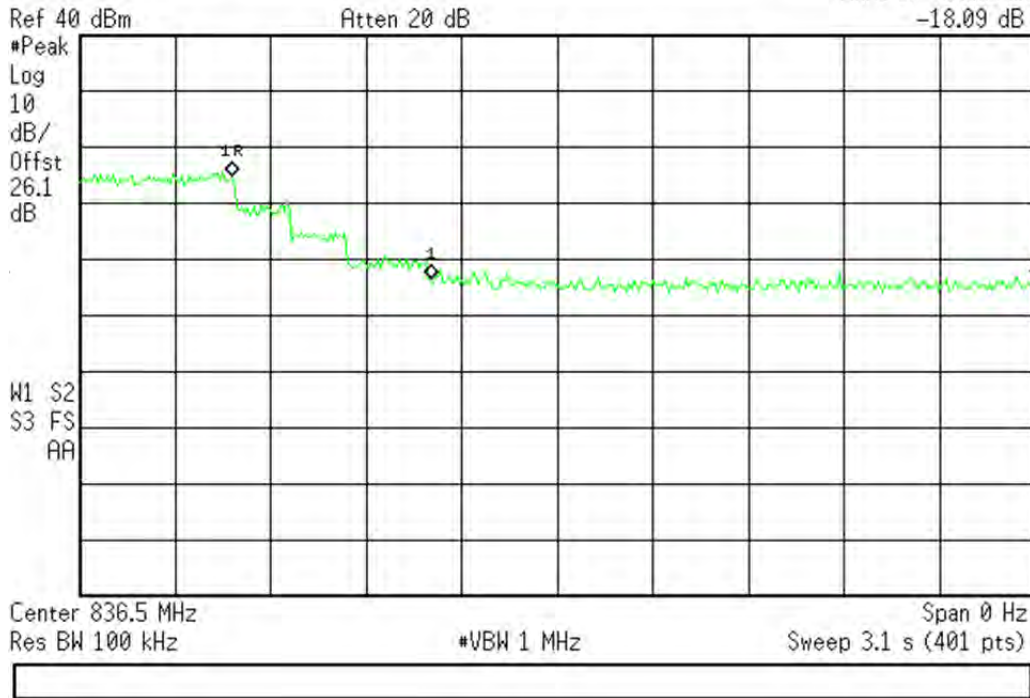

Uplink Gain Timing Test Plot 1710 – 1755 MHz

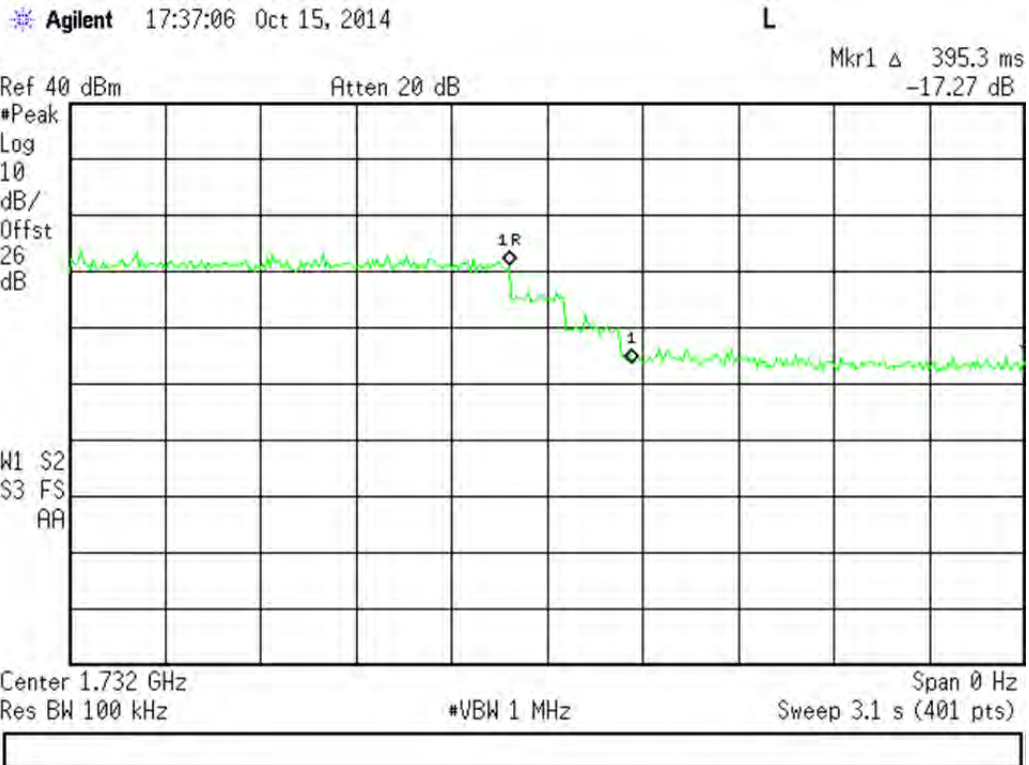

Uplink Gain Timing Test Plot 1850 - 1915 MHz

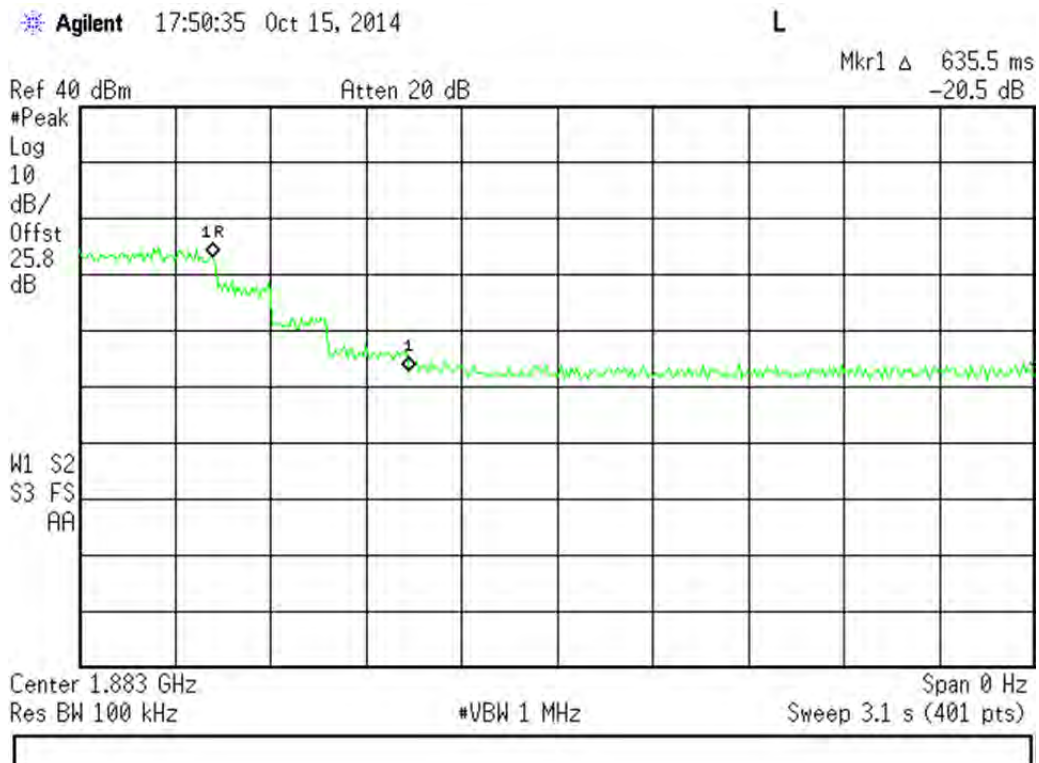

Occupied Bandwidth

Engineer: Mike Graffeo

Test Date: 9/29/14

Test Procedure

The EUT was connected to a spectrum analyzer through an attenuator with the losses being input into the spectrum analyzer as a combination of reference level offset and correction factor as required to ensure that accurate readings were obtained. A signal generator was utilized to produce the following signals: GSM, CDMA, and WCDMA. The signal generator was tuned to the center channel of each of the EUT operational uplink and downlink bands with the RF level set at a point just prior to the AGC being in control of the power. For each modulation type, the input and output signal was measured and plotted to ensure that the signals were similar.

Test Setup

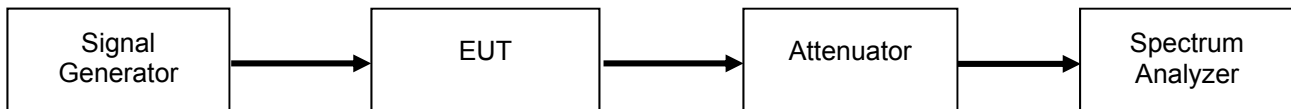

GSM Uplink Test Plots

698 - 716 MHz Band

Input

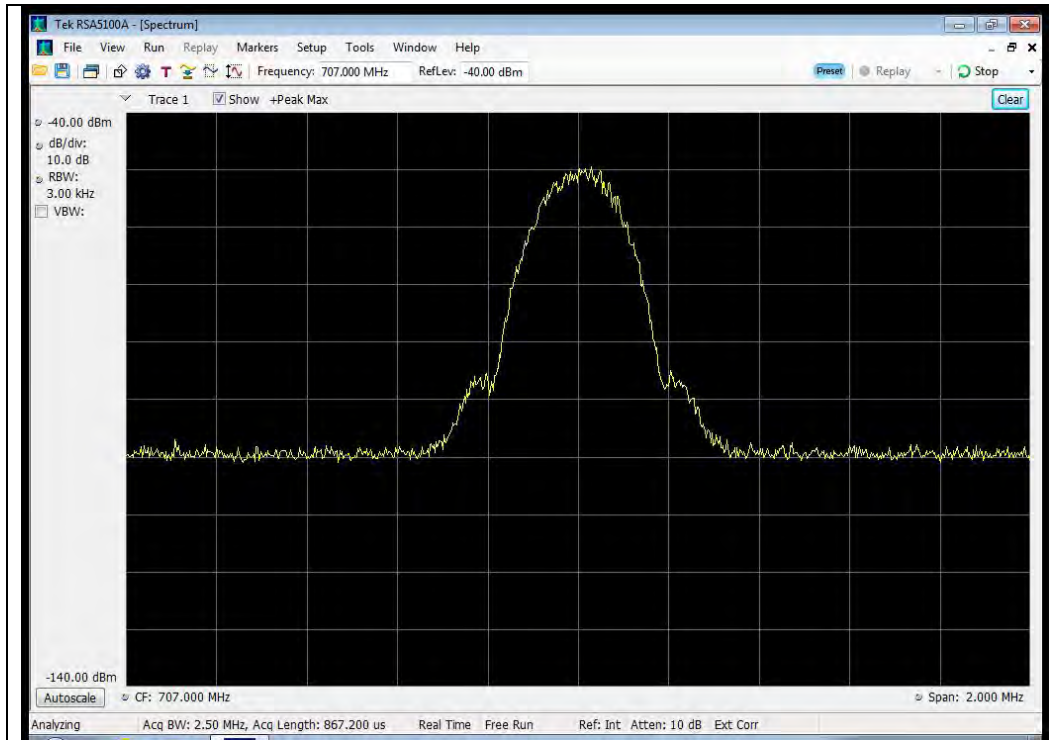

Output

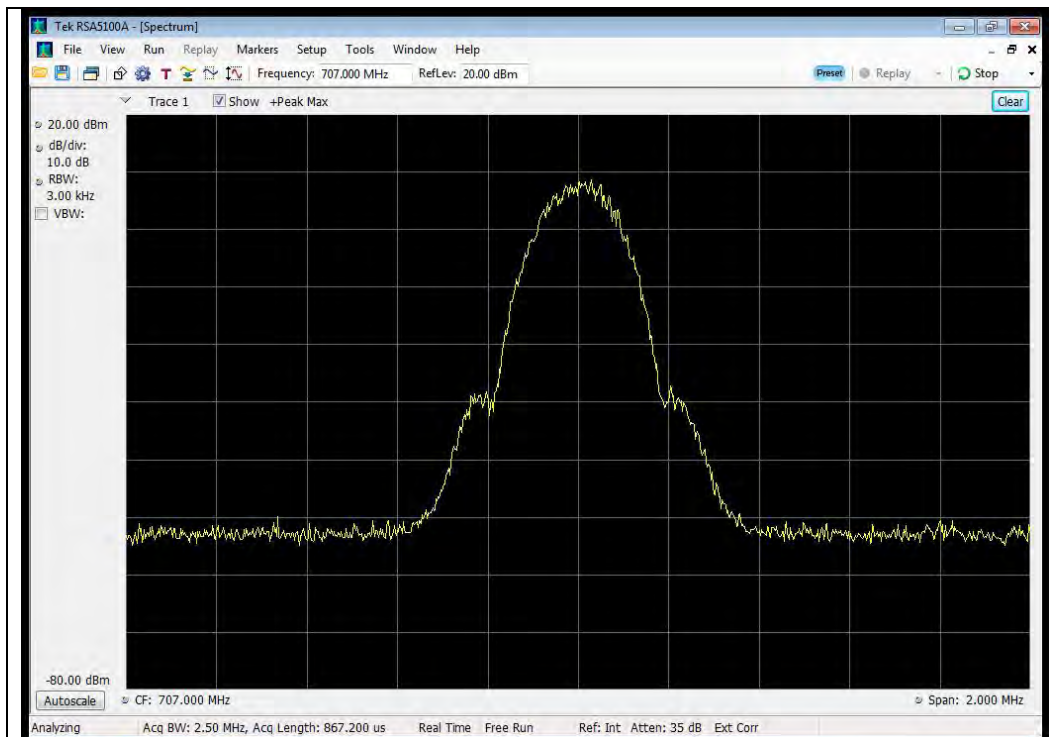

776 - 787 MHz Band

Input

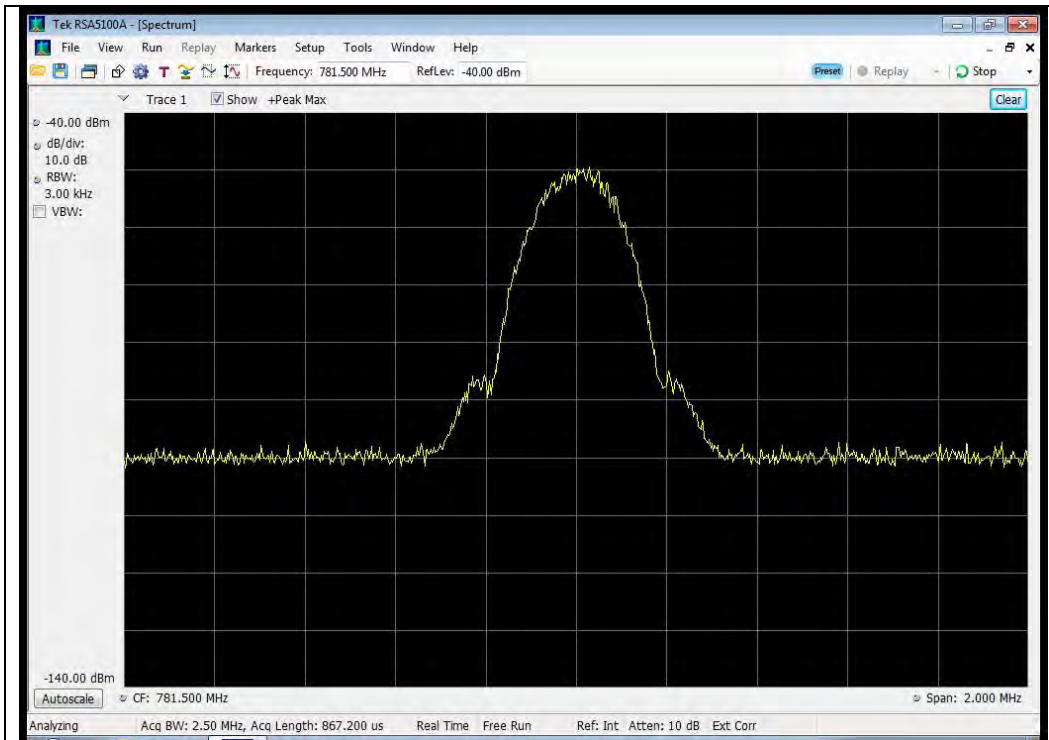

Output

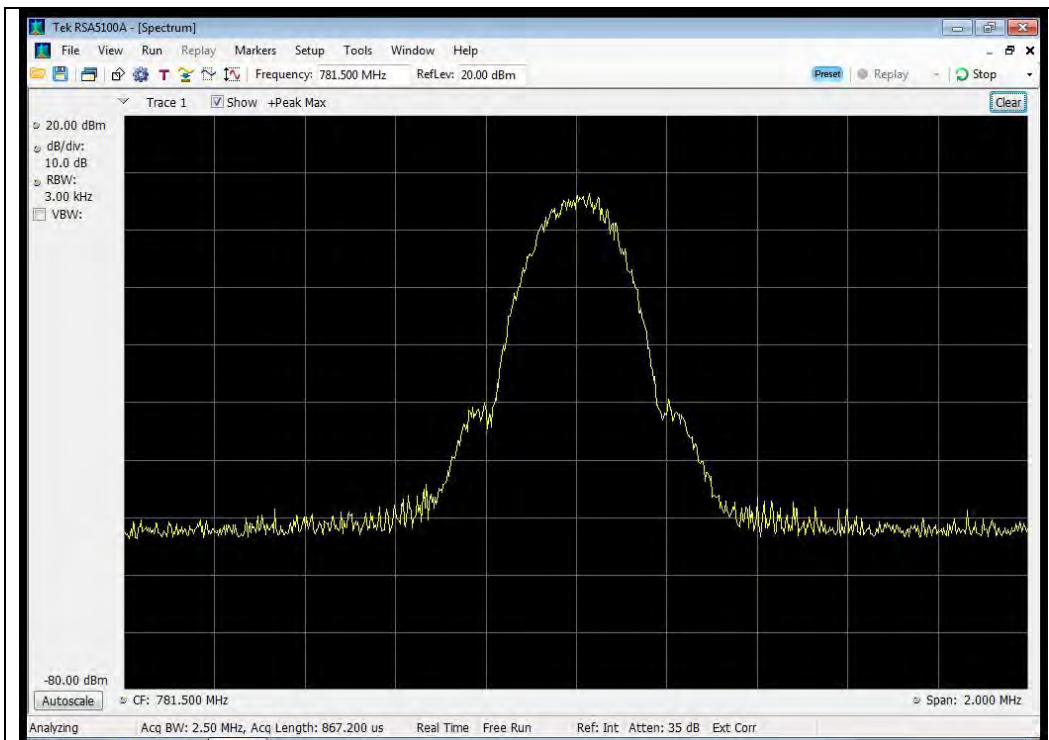

824 - 849 MHz Band

Input

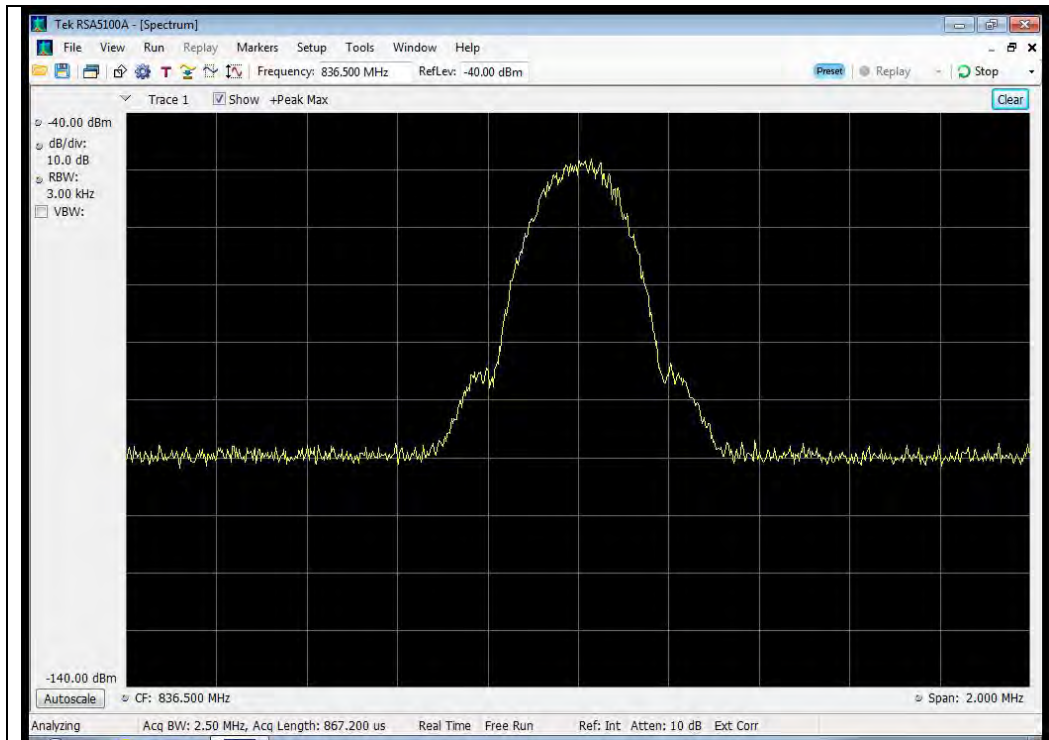

Output

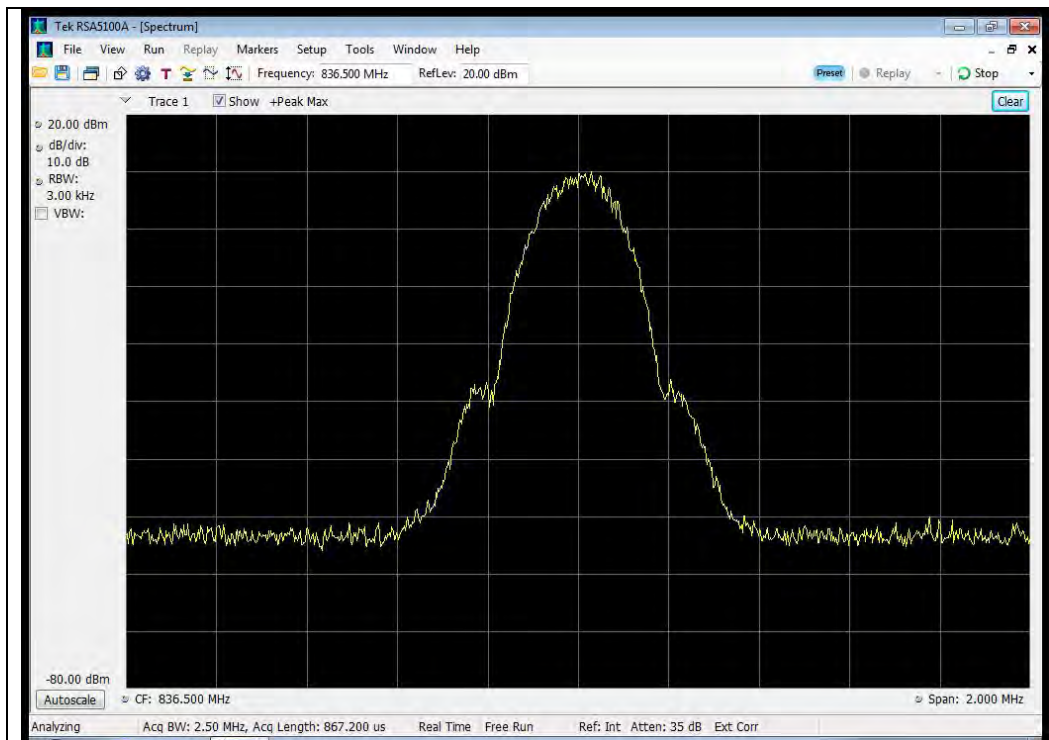

1710 - 1755 MHz Band

Input

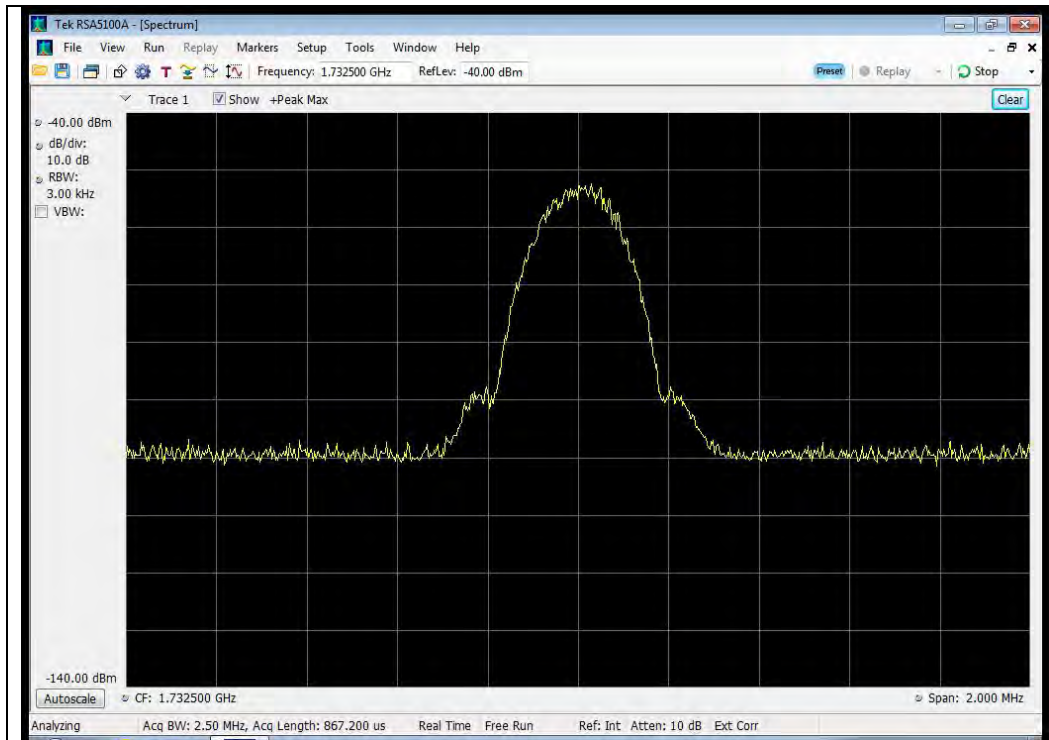

Output

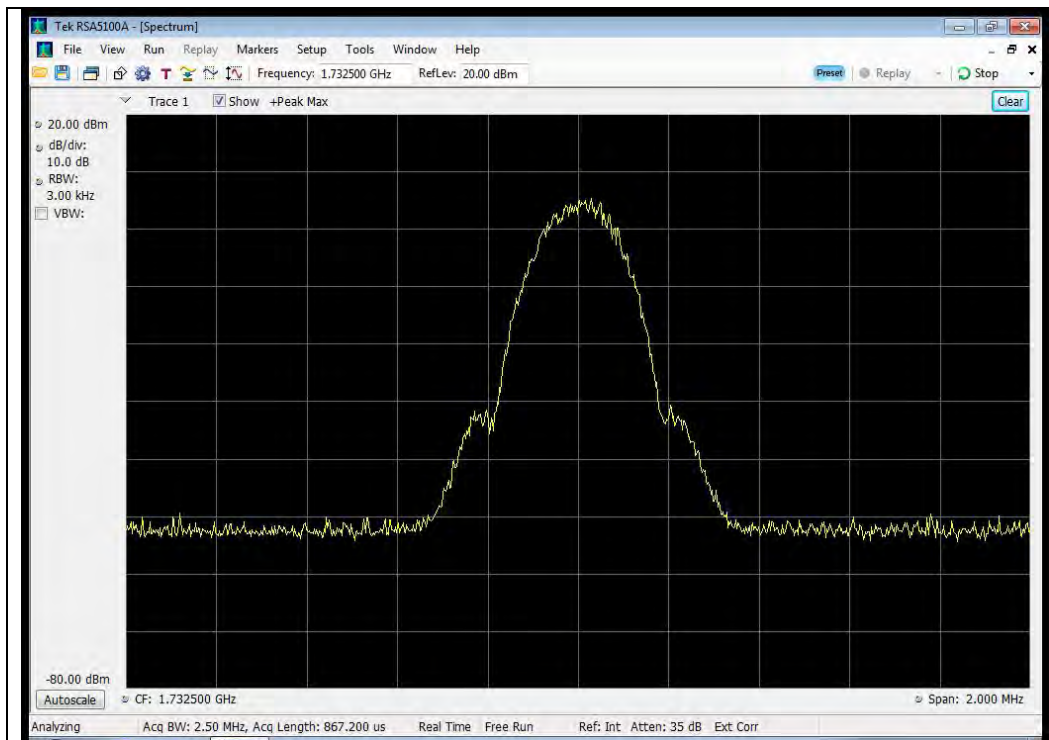

1850 - 1915 MHz Band

Input

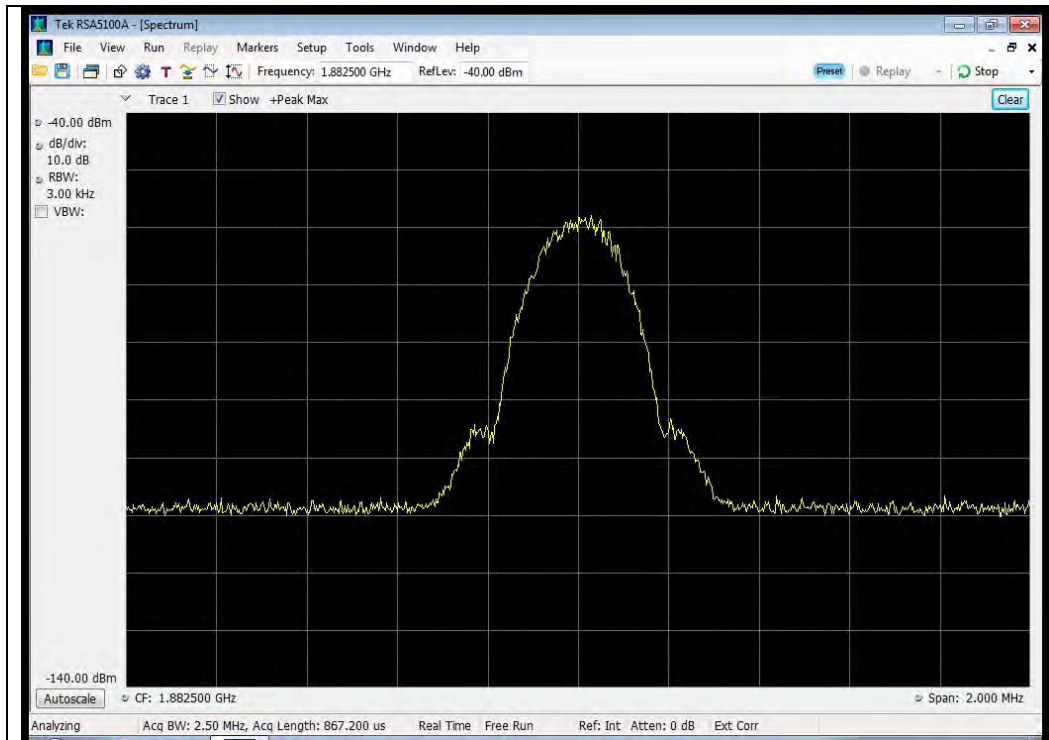

Output

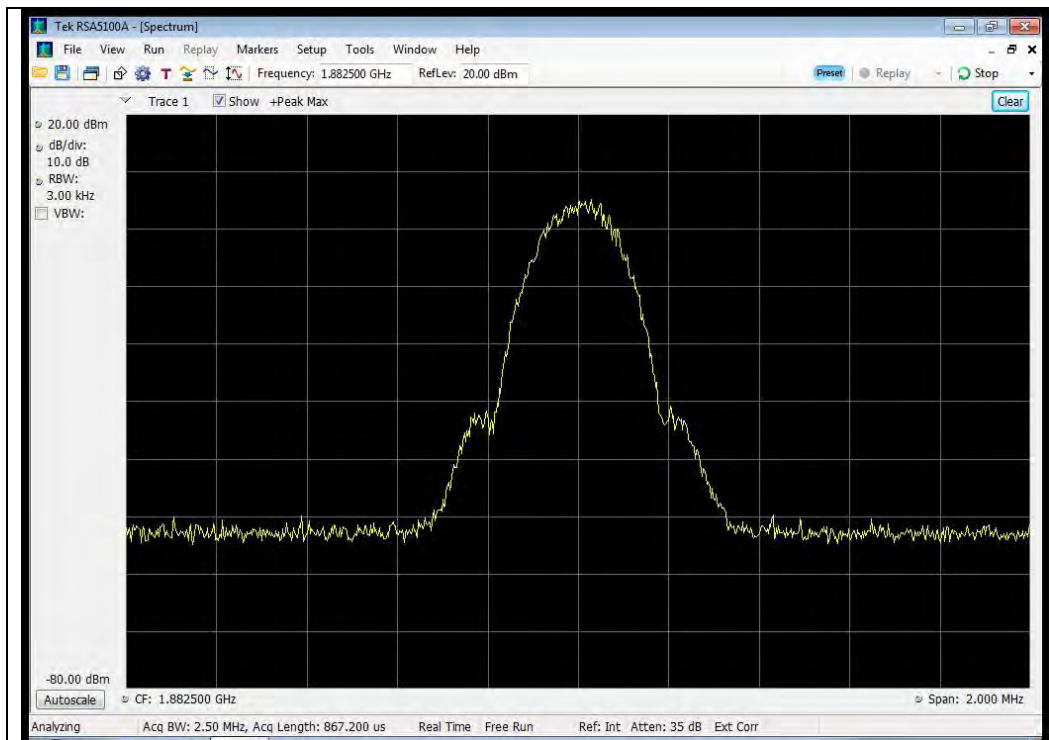

GSM Downlink Test Plots

728 - 746 MHz Band

Input

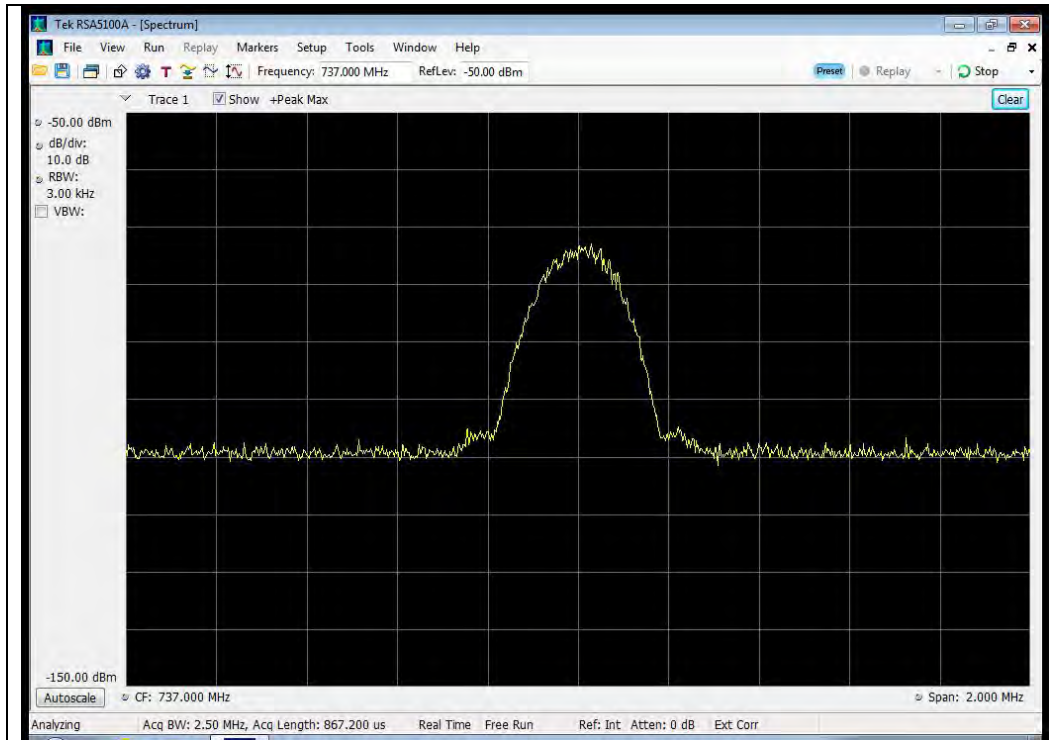

Output

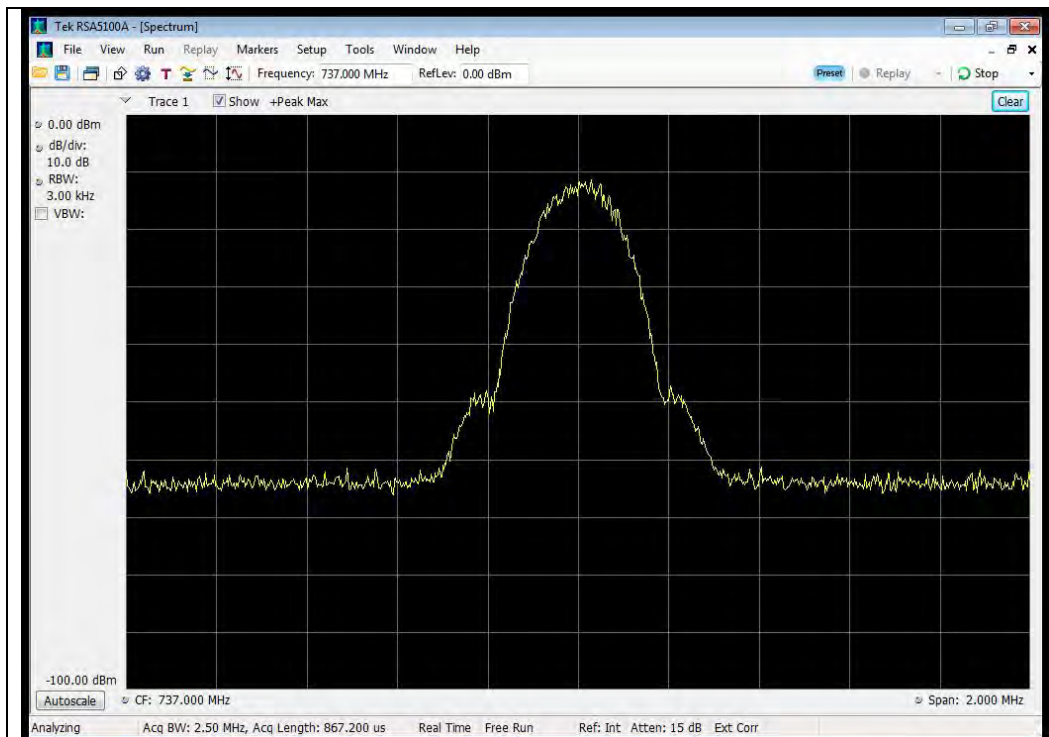

746 - 757 MHz Band

Input

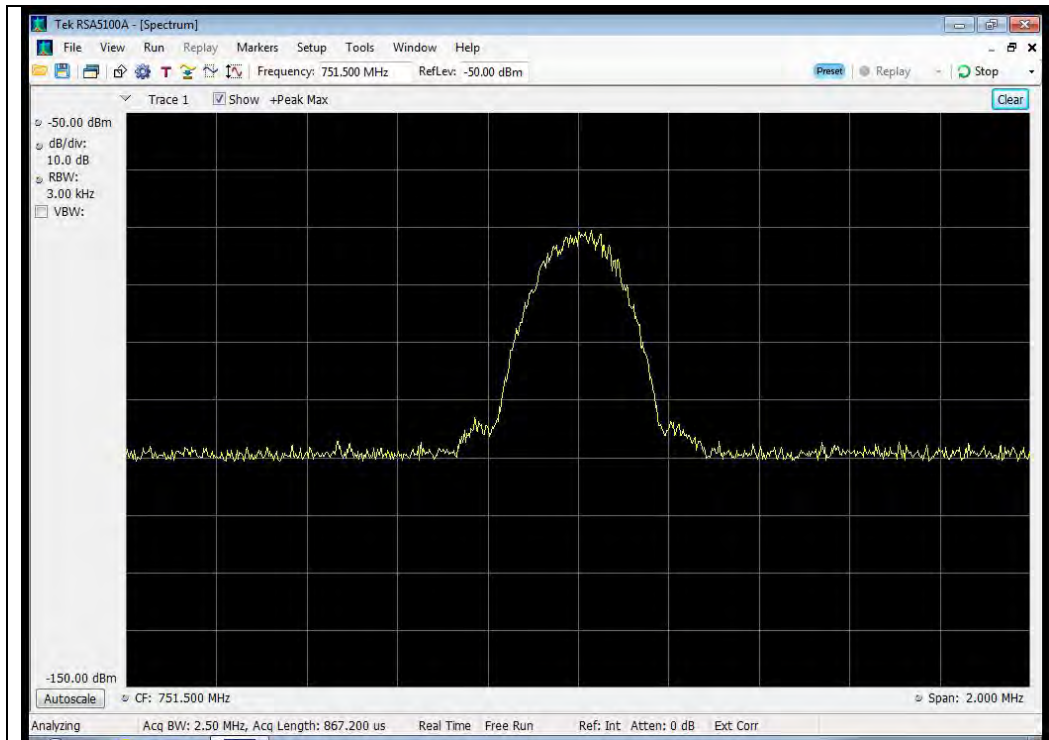

Output

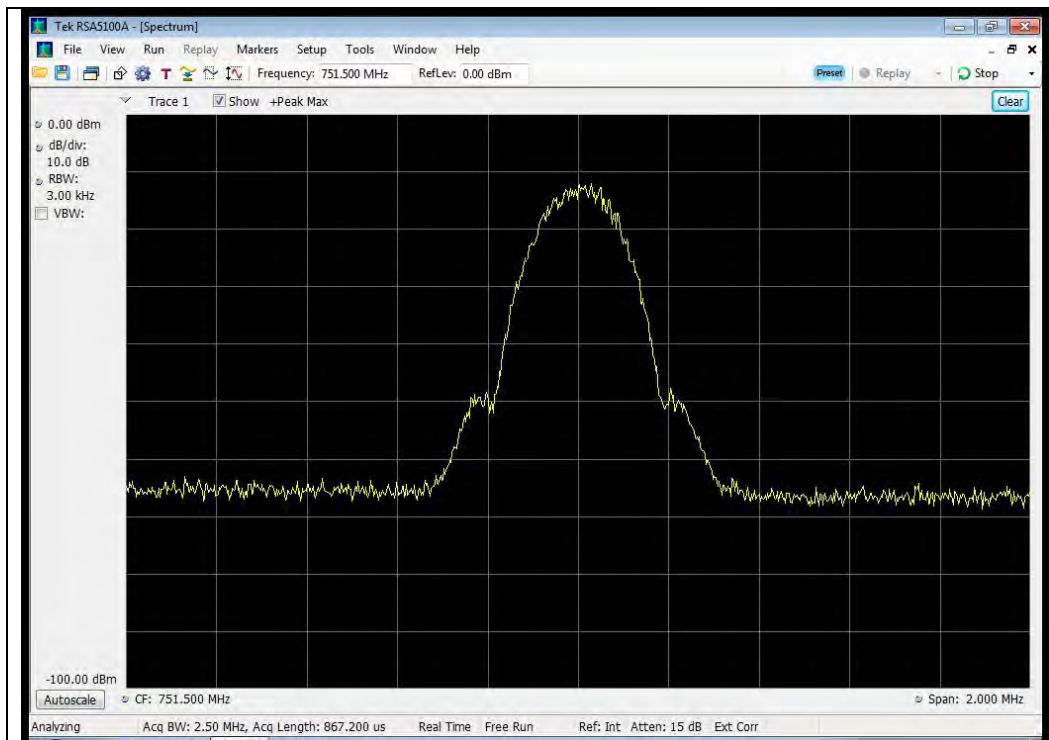

869 - 894 MHz Band

Input

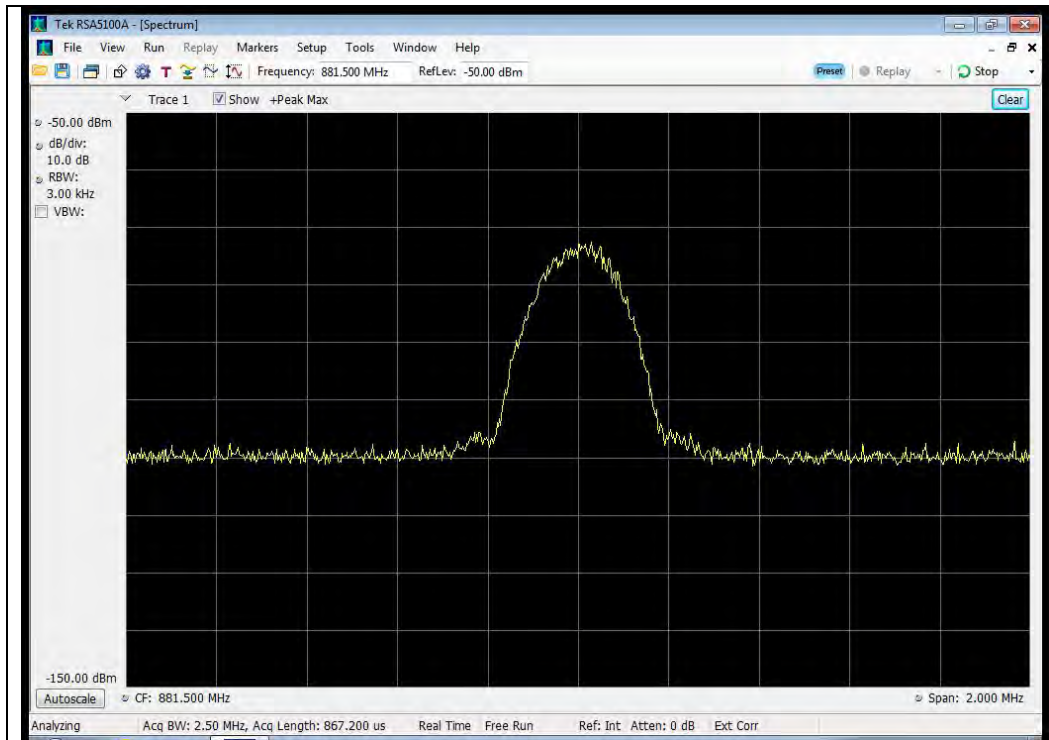

Output

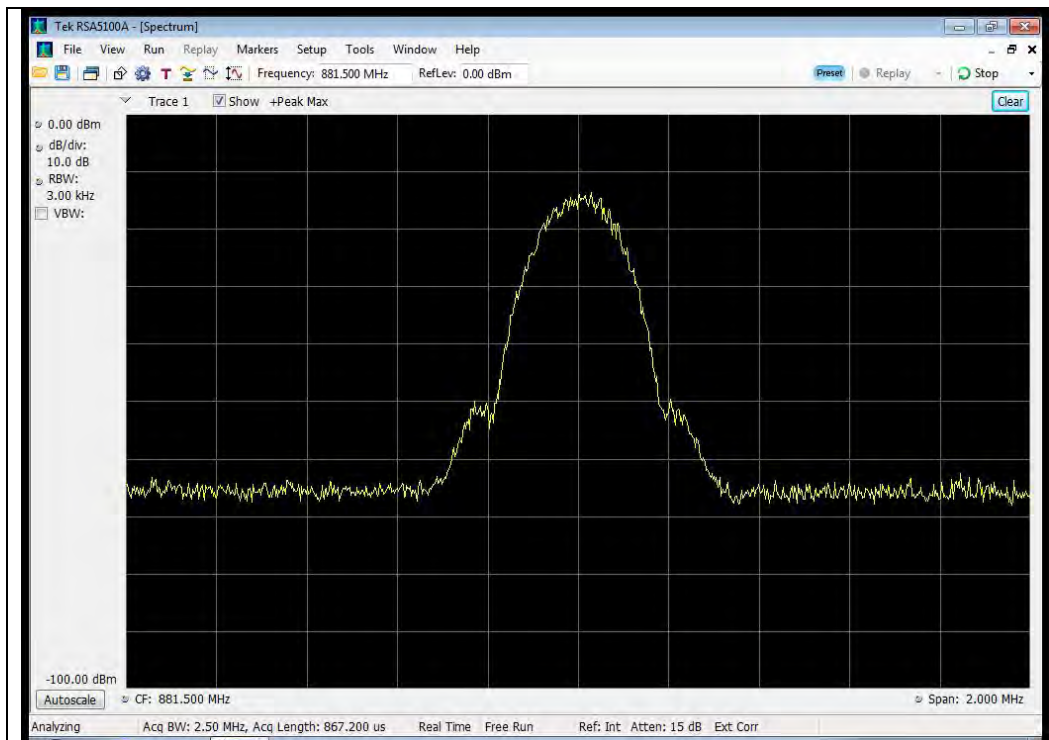

1930 - 1995 MHz Band

Input

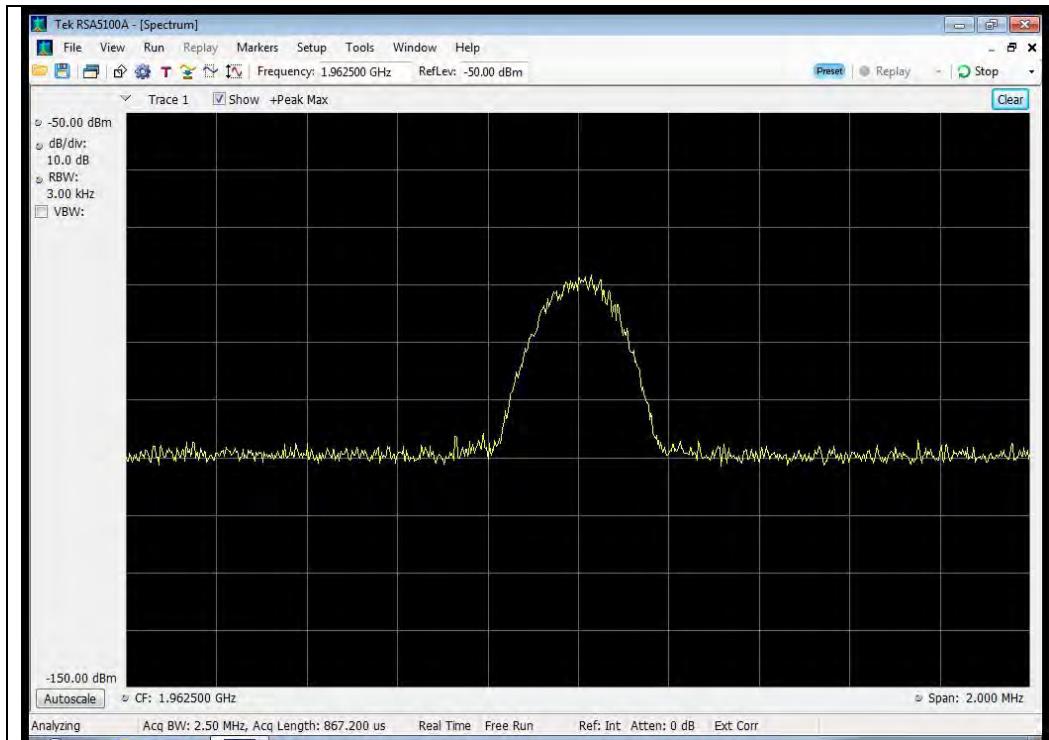

Output

