

User's Manual

BT5.0 Module

BM-52840

Manufacturer : Kunshan CC&C Technologies, Co., LTD.

Bluetooth 5 Module

Description

BM-52840 is a Bluetooth 5 Low Energy class 1 module that provides a complete solution from various interfaces to different sensors to BLE protocol stack and applications. It includes 32MHz crystal and a system-on-chip Nordic nRF52840. The minimal parts count and small footprint of the BM-52840 is ideally suited for the requirement of high integration Bluetooth Low Energy technology in portable devices and consumer electronics.

The system-on-chip architecture design of the module makes a much smaller space and minimal cost and simplifies the whole system design.

Features

- Small footprint: 11.3×20×1.8mm
26-pin perforated hole.
- Bluetooth 5 ready multiprotocol radio
- Bluetooth 5 data rate support: 2 Mbs,

1Mbs, 500 kbs, 125 kbs

- Bluetooth 5 support for long range and high throughput
- AES 128-bit ECB/CCM/AAR hardware accelerator
- -96 dBm Sensitivity for Bluetooth low energy
- 12 bit /200K SPS ADC

Application

- Advanced wearables
 - Connected watches
 - Advanced personal fitness devices
 - Wearables with wireless payment
 - Connected health
 - Virtual/Augmented Reality applications
- Internet of Things (IoT)
 - Smart home sensors and controllers
 - Industrial IoT sensors and controllers
- Interactive entertainment devices
 - Advanced Remote controls
 - Gaming controllers

Revision History

Version	Date	Change Description
1.0	11/3, 2017	Initial release

Note : All electrical and mechanical specifications may be changed by CC&C Technologies, Inc. without notice.

Functional Block Diagram

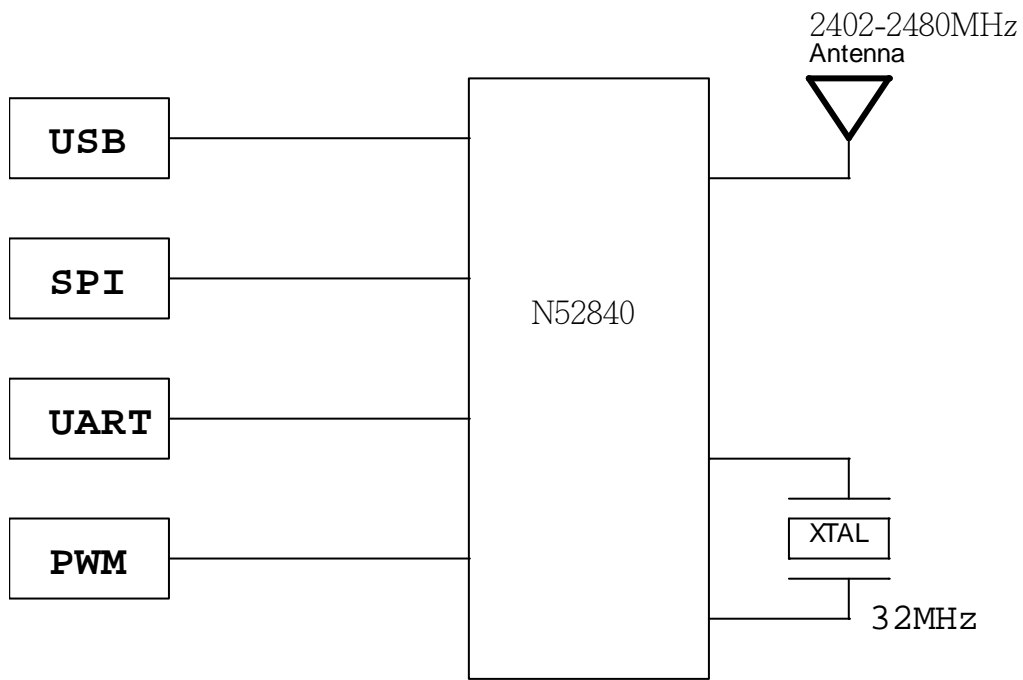

BM-52840
Block Diagram

Pin Assignment (Top view)

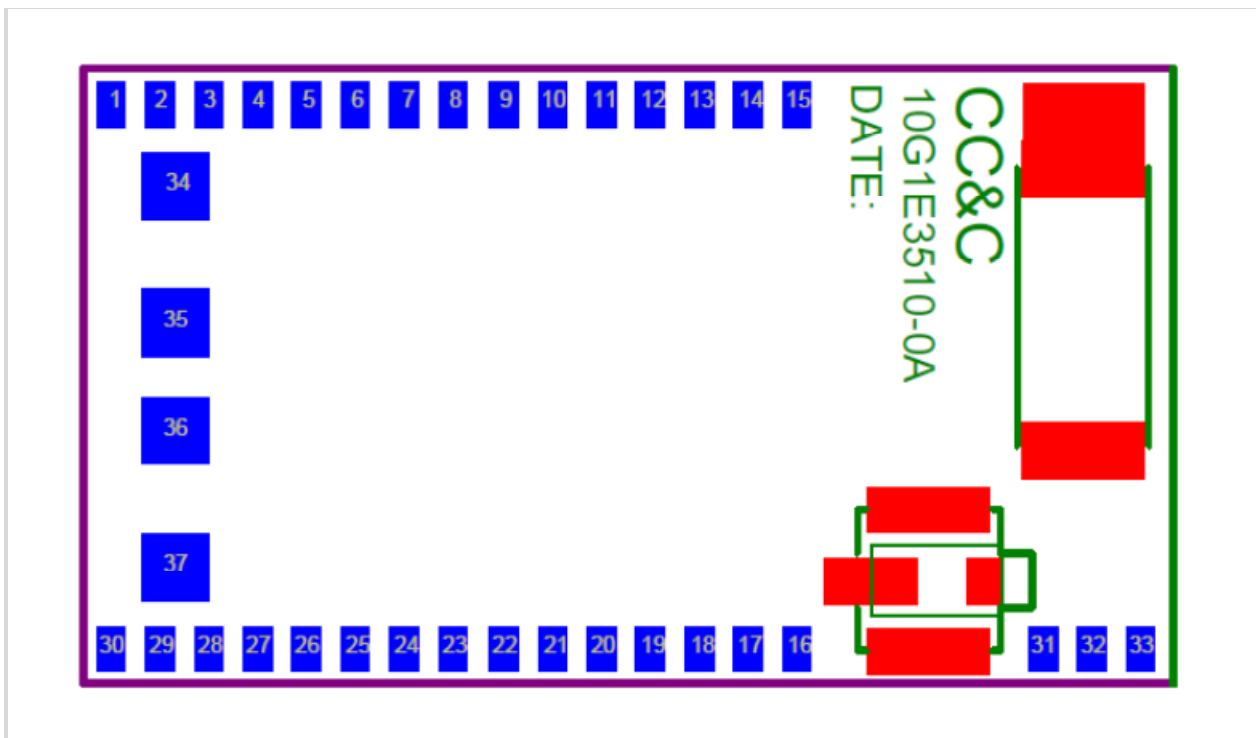

Pin Definition

Pin	Signal	Function	Description
1	GND	Ground	Ground
2	P0.17	I/O	Programmable I/O
3	P0.12	I/O	Programmable I/O
4	VBUS	Power	Operating supply voltage 4.35~5.5V
5	P0.29	GPIO.	Programmable I/O , Analog input
6	GND	Ground	Ground
7	VDD	Power	Operating supply voltage 1.7~3.6V
8	P0.26	I/O	Programmable I/O
9	P0.04	I/O	Programmable I/O, Analog input
10	P0.01	I/O	Programmable I/O
11	P0.02	I/O	Programmable I/O, Analog input
12	P0.00	I/O	Programmable I/O
13	P1.15	I/O	Programmable I/O
14	DCC	I/O	DC/DC converter output
15	DEC4	I/O	1.3 V regulator supply decoupling
16	SWDIO	Debug	Debug serial data
17	SWDCLK	Debug	Serial wire debug clock input for debug and programming
18	P1.00	I/O	Programmable I/O
19	P0.24	I/O	Programmable I/O
20	P0.03	I/O	Programmable I/O, Analog input
21	P1.14	I/O	Programmable I/O
22	P1.13	I/O	Programmable I/O
23	P1.11	I/O	Programmable I/O
24	P0.10	I/O	Programmable I/O
25	P0.09	I/O	Programmable I/O
26	P1.06	I/O	Programmable I/O
27	P0.18/RESET	I/O	Programmable I/O ,Configurable as system RESET
28	P1.02	I/O	Programmable I/O
29	P1.04	I/O	Programmable I/O
30	P0.20	I/O	Programmable I/O
31	P1.10	I/O	Programmable I/O
32	RFIO_OUT	RF	BT RF port
33	GND	Ground	Ground
34	VBUS	Power	Operating supply voltage 4.35~5.5V
35	USB_DP	I/O	USB D+
36	USB_DN	I/O	USB D-
37	GND	Ground	Ground

SPECIFICATION

Product Name	Bluetooth 5.0 Module
Model Number	BM-52840
Operating Frequency	2402-2480GHz
Tx power(max)	6dBm
Receiver sensitivity	-96dBm

Power Voltage Range

Symbol	Description	Min.	Typ.	Max.	Units
VBUS	System power voltage	4.3	5	5.5	V
VCC_IO	I/O power voltage	-0.3		3.9	V
Current Consumption	Tx mode 0dBm		11.6		mA
	Tx mode 6dBm		27.6		mA
	Rx mode		12.9		mA
	Storage Temperature	-40	25	125	°C

APPLICATION CIRCUIT

The application circuit of BM-52840 is shown below. It uses a UART-to-USB converter IC PL-2303 so developing firmware on PC becomes more convenient.

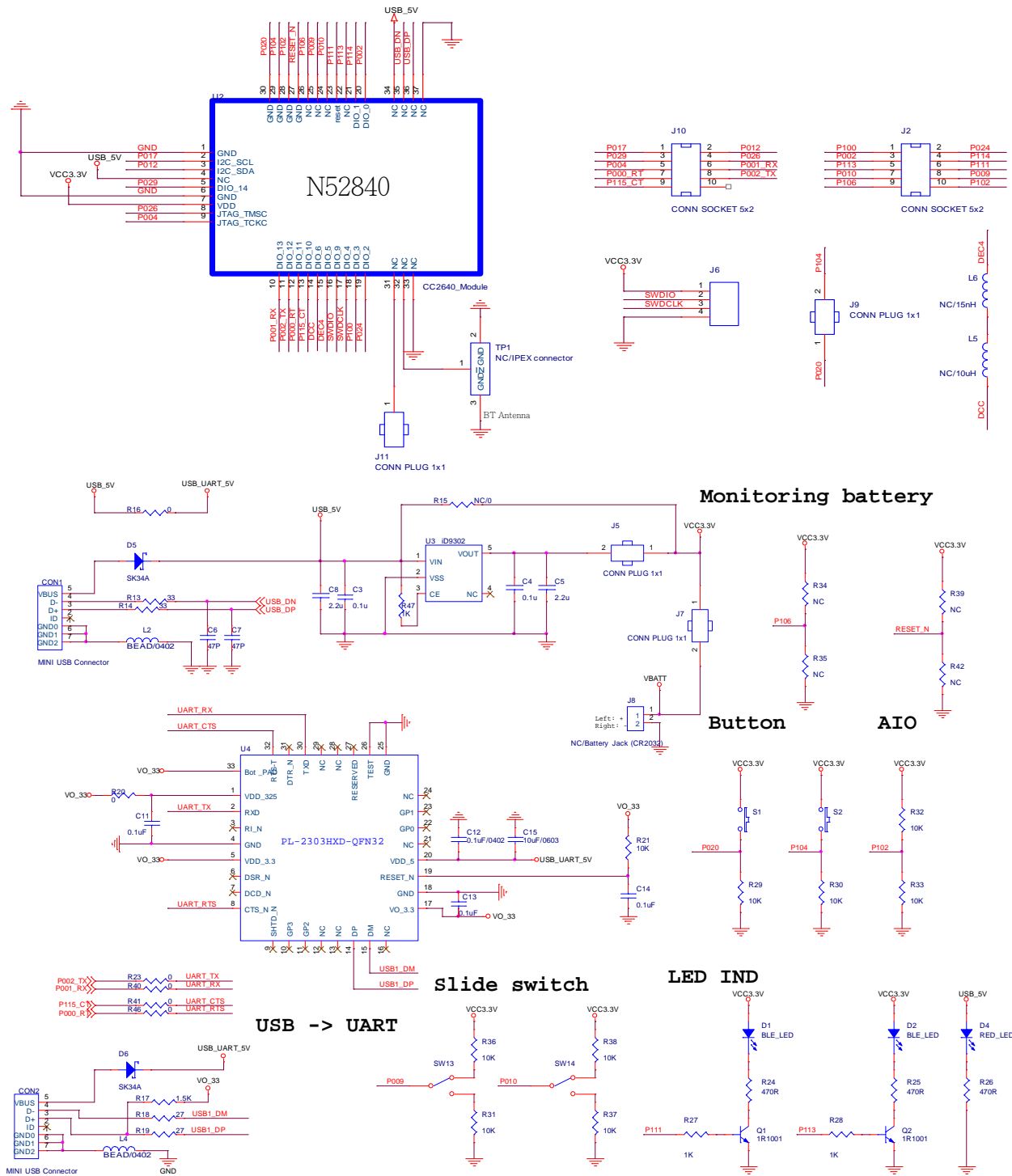

Package Diagram

The thickness of BM-52840 is 1.8mm.

**All dimensions are in millimeters.
Tolerance $\pm 0.15\text{mm}$**

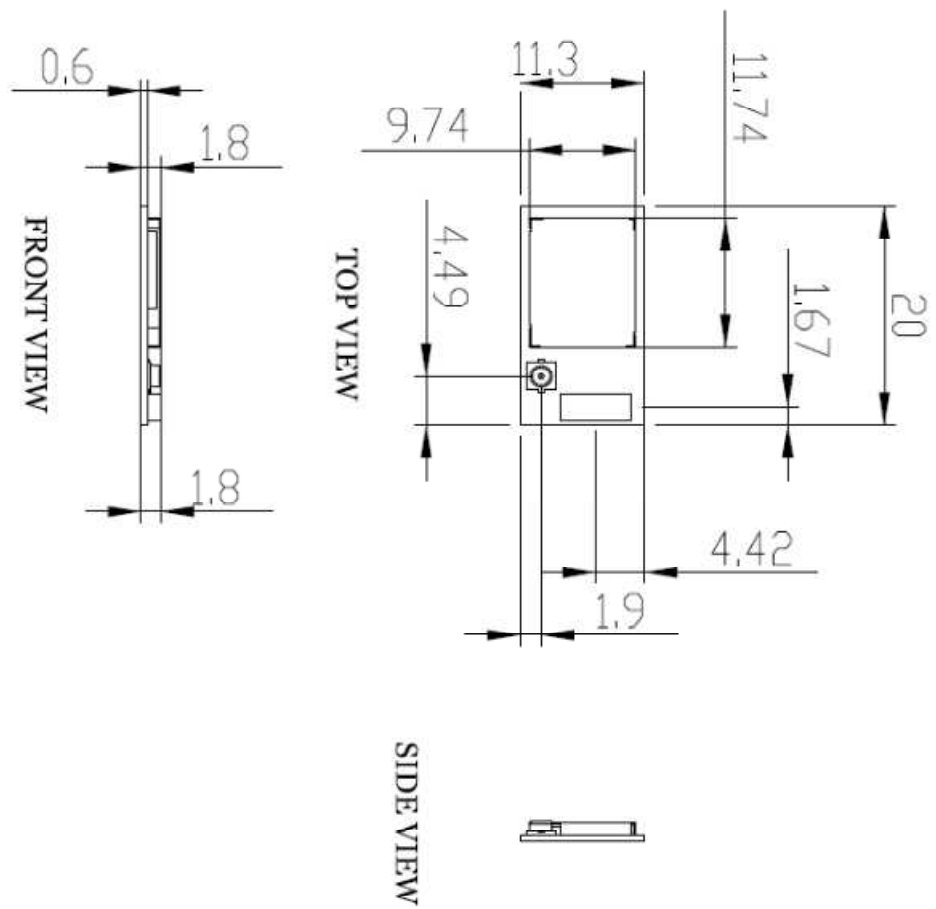

Pad Dimensions (bottom view)

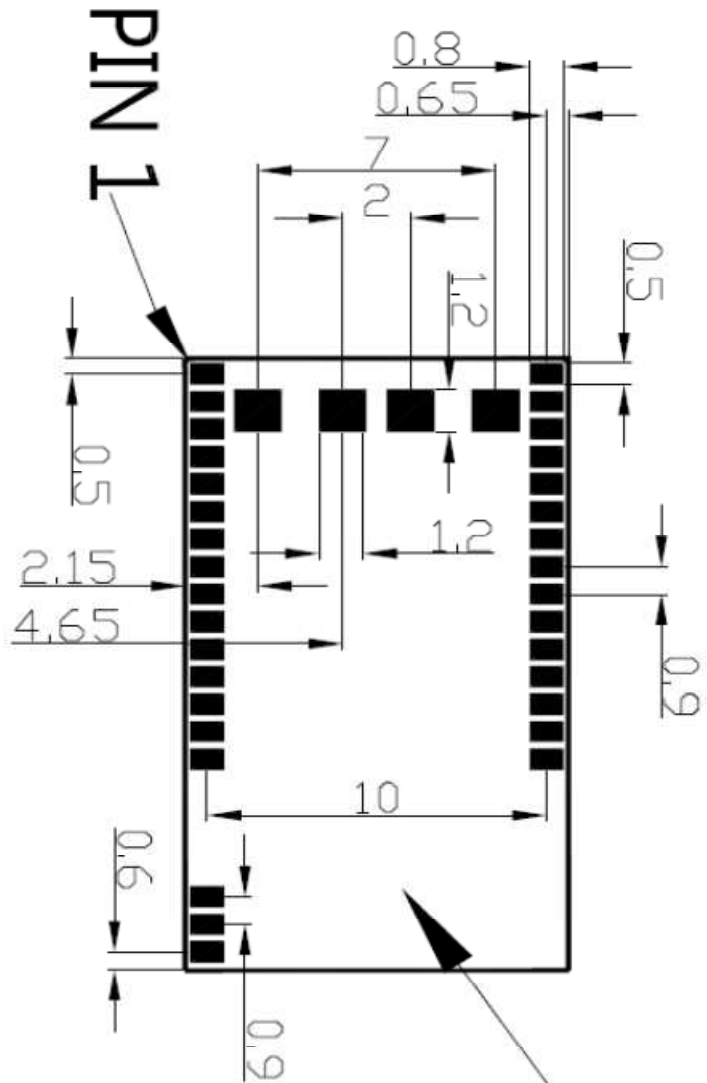

Height limit=0

BOTTOM VIEW

All dimensions are in millimeters.

Placement Guideline

It is recommended that BM-52840 be placed on the corner of the main board or near the edge as shown below.

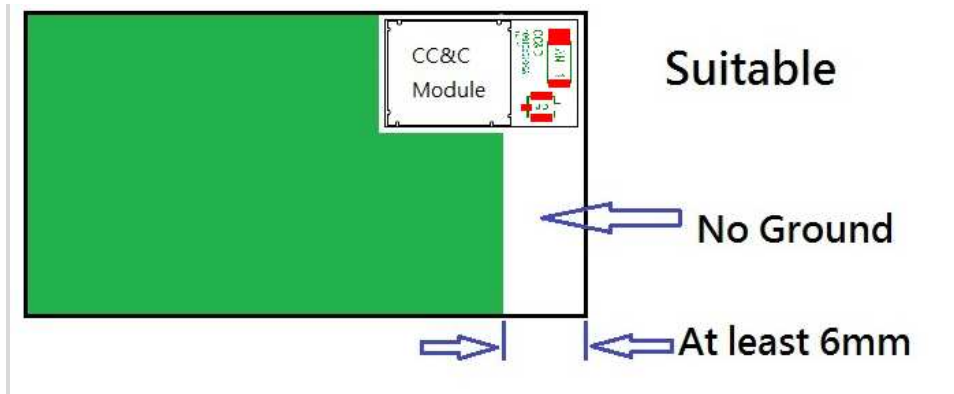

On the corner

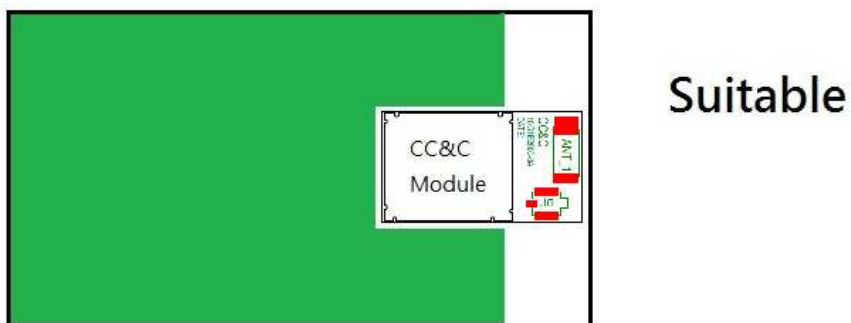

Near the edge

However, placing BM-52840 inside the main board affects the RF performance and may reduce the RF range significantly.

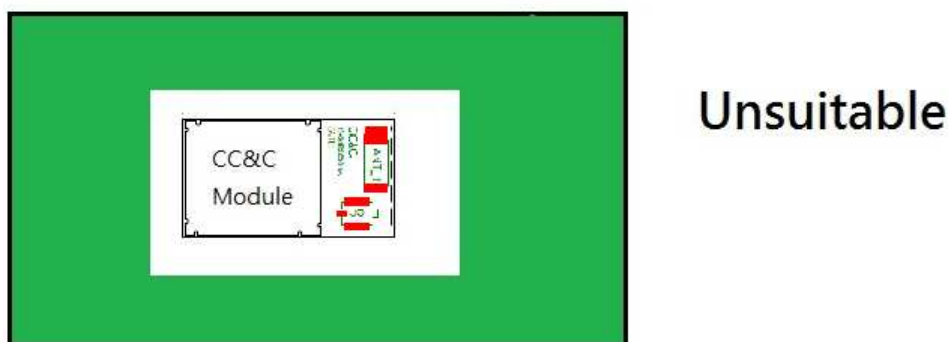

FCC Warning

This device complies with Part 15 of the FCC Rules. Operation is subject to the following two conditions:

- (1) this device may not cause harmful interference, and
- (2) this device must accept any interference received, including interference that may cause undesired operation.

NOTE: Any changes or modifications to this unit not expressly approved by the party responsible for compliance could void the user's authority to operate the equipment.

FCC Radiation Exposure Statement:

This equipment complies with FCC radiation exposure limits set forth for an uncontrolled environment. End users must follow the specific operating instructions for satisfying RF exposure compliance. This transmitter must not be co-located or operating in conjunction with any other antenna or transmitter.

Note 1: Compliance of this device in all final host configurations is the responsibility of the Grantee.

OEM integrators are responsible to satisfy RF exposure requirements. SAR evaluation is valid for portable, mobile and fixed applications.

Note 2: Any modifications made to the module will void the Grant of Certification, this module is limited to OEM installation only and must not be sold to end-users, end-user has no manual instructions to remove or install the device, only software or operating procedure shall be placed in the end-user operating manual of final products.

Note 3: The device must not transmit simultaneously with any other antenna or transmitter.

Note 4: To ensure compliance with all non-transmitter functions the host manufacturer is responsible for ensuring compliance with the module(s) installed and fully operational. For example, if a host was previously authorized as an unintentional radiator under the Declaration of Conformity procedure without a transmitter certified module and a module is added, the host manufacturer is responsible for ensuring that after the module is installed and operational the host continues to be compliant with the Part 15B unintentional radiator requirements. Since this may depend on the details of how the module is integrated with the host, CC&C Technologies, Inc. shall provide guidance to the host manufacturer for compliance with the Part 15B requirements.

Note 5: FCC ID label on the final system must be labeled with "Contains FCC ID: PANBM52840"

The transmitter module must be installed and used in strict accordance with the manufacturer's instructions as described in the user documentation that comes with the host product. CC&C Technologies, Inc. is responsible for the compliance of the module in all final hosts.