

# SAR Test Report

Product Name: GSM Mobile Phone

Model No: U-140-2

FCC ID: OLEU140

Applicant : PARKTEL FZE

Address : WARE HOUSE NO: FF01,ROUND ABOUT NO:  
05,JEBEL ALI FREEZONE DUBAI U.A.E



Prepared : IAC Compliance Laboratory

Address : No.789 Pu Xing Road,Shanghai,PRC

Date of Test : 2013.04.17

### Test Report Certification

Test Date : 2013.04.17

Report No. : 130418001SAR-FCC

Product Name : GSM Mobile Phone  
Applicant : PARKTEL FZE  
Address : WARE HOUSE NO: FF01,ROUND ABOUT NO:  
05,JEBEL ALI FREEZONE DUBAI U.A.E  
Manufacturer : PROFIT HARVEST CORPORATION LIMITED  
Model No. : U-140-2  
Serial Model No : U-140-1  
Standard : FCC 47 CFR Part2 (2.1093)  
IEEE C95.1-1999  
IEEE 1528-2003  
FCC OET Bulletin 65 supplement C

Test Result : Complied

The Test Results relate only to the samples tested.

The test report shall not be reproduced except in full without the written approval of IAC Compliance Lab.

Documented By :   
Judy Ge/Engineer

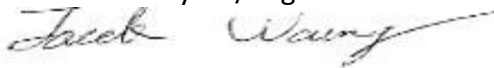
Tested By :   
Jack Wang/Engineer

Approved By :   
Jeff Huang/Director of Operations

---

**TABLE OF CONTENTS**

Description	Page
<b>1. GENERAL INFORMATION.....</b>	<b>4</b>
1.1. APPLICANT.....	4
1.2. MANUFACTURER.....	4
1.3. TEST ENVIRONMENT.....	4
1.4. EUT DESCRIPTION.....	4
<b>2. SAR MEASUREMENT SYSTEM.....</b>	<b>5</b>
2.1. ALSAS-10U SYSTEM DESCRIPTION.....	5
2.2. ISOTROPIC E-FIELD PROBE.....	7
2.3. BOUNDARY DETECTION UNIT AND PROBE MOUNTING DEVICE.....	8
2.4. DAQ-PAQ (ANALOG TO DIGITAL ELECTRONICS).....	9
2.5. AXIS ARTICULATED ROBOT.....	9
2.6. ALSAS UNIVERSAL WORKSTATION.....	10
2.7. UNIVERSAL DEVICE POSITIONER.....	10
2.8. PHONTOM TYPES.....	10
<b>3. TISSUE SIMULATING LIQUID.....</b>	<b>12</b>
3.1. THE COMPOSITION OF THE TISSUE SIMULATING LIQUID.....	12
3.2. TISSUE CALIBRATION RESULT.....	12
3.3. TISSUE DIELECTRIC PARAMETERS FOR HEAD AND BODY PHANTOMS.....	13
<b>4. SAR MEASUREMENT PROCEDURE.....</b>	<b>15</b>
4.1. SAR SYSTEM VALIDATION.....	15
4.2. ARRANGEMENT ASSESSMENT SETUP.....	21
4.3. SAR MEASUREMENT PROCEDURE.....	23
<b>5. SAR EXPOSURE LIMITS.....</b>	<b>24</b>
<b>6. TEST EQUIPMENT LIST.....</b>	<b>25</b>
<b>7. MEASUREMENT UNCERTAINTY.....</b>	<b>26</b>
<b>8. SAR TEST RESULTS.....</b>	<b>27</b>
8.1. CONDUCTED POWER(UNIT:DBM).....	27
8.2. SAR TEST RESULTS SUMMARY.....	28
8.3. SAR MEASUREMENT DATA.....	28
<b>SAR TEST PHOTOGRAPHS.....</b>	<b>40</b>

## 1. GENERAL INFORMATION

### 1.1. Applicant

Company Name: PARKTEL FZE

Address: WARE HOUSE NO: FF01,ROUND ABOUT NO: 05,JEBEL ALI FREEZONE DUBAI U.A.E

### 1.2. Manufacturer

Company Name: PROFIT HARVEST CORPORATION LIMITED

Address: FLAT/RM 506C 5/F INNOCENTRE 72 TAT CHEE AVENUE KOWLOON TONG KL

### 1.3. Test Environment

Ambient conditions in the laboratory:

Items	Required	Actual
Temperature(°C)	15~30	21.4
Humidity(%RH)	30~70	46

### 1.4. EUT Description

Device type	Portable Device		
EUT Stage	Production unit		
Antenna Type	Inner PIFA antenna		
Operation Model(s)	GSM850/1900		
Tx Frequency	824.2-848.8,1850.2-1909.8MHz		
HW Version	SP11D_MB_V2.0		
SW Version	JSP11DP0220_GST_SP11D_S330_PARKTEL_M10_3232_MF_V02_20130320_stone		
Accessories	Brand:unnecto ™	Model:BU-140	Rated Voltage:3.7V Capacity:600mAh
	Brand:unnecto ™	Model:CU-140	Input AC:100-240V 50/60Hz 0.15A Output DC:5V/500mAh

## 2. SAR Measurement System

### 2.1. ALSAS-10U System Description

ALSAS-10-U is fully compliant with the technical and scientific requirements of IEEE 1528, IEC 62209, CENELEC, ARIB, ACA, and the Federal Communications Commission. The system comprises of a six axes articulated robot which utilizes a dedicated controller.

ALSAS-10U uses the latest methodologies and FDTD order to provide a platform which is repeatable with minimum uncertainty.

#### 2.1.1. Applications

Predefined measurement procedures compliant with the guidelines of CENELEC, IEEE, IEC, FCC, etc are utilized during the assessment for the device. Automatic detection for all SAR maxima are embedded within the core architecture for the system, ensuring that peak locations used for centering the zoom scan are within a 1mm resolution and a 0.05mm repeatable position. System operation range currently is available up to 6 GHz in simulated tissue.



### 2.1.2. Area Scans

Area Scans are defined prior to the measurement process being executed with a user defined variable spacing between each measurement point (integral) allowing low uncertainty measurements to be conducted. Scans defined for FCC applications utilize a  $10\text{mm}^2$  step integral, with 1mm interpolation used to locate the peak SAR area used for zoom scan assessments.

Where the system identifies multiple SAR peaks (which are within 25% of peak value) the system will provide the user with the option of assessing each peak location individually for zoom scan averaging.

### 2.1.3. Zoom Scan (Cube Scan Averaging)

The averaging zoom scan volume utilized in the ALSAS-10U software is in the shape of a cube and the side dimension of a 1g or 10g mass is dependent on the density of the liquid representing the simulated tissue. A density of  $1000\text{kg}/\text{m}^3$  is used to represent the head and body tissue density and not the phantom liquid density, in order to be consistent with the definition of the liquid dielectric properties, i.e. the side length of the 1g cube is 10mm, with the side length of the 10g cube 21.5mm.

When the cube intersects with the surFront of the phantom, it is oriented so that 3 vertices touch the surFront of the shell or the center of a Front is tangent to the surFront.

The zoom Scan integer steps can be user defined so as to reduce uncertainty, but normal practice for typical test applications (including FCC) utilize a physical step of  $5 \times 5 \times 8$  (8mm $\times$ 8mm $\times$ 5mm) providing a volume of 32mm in the X & Y axis, and 35mm in the Z axis.

### 2.1.4. ALSAS-10U Interpolation and Extrapolation Uncertainty

The overall uncertainty for the methodology and algorithms the used during the SAR calculation was evaluated using the data from IEEE 1528 based on the example f3 algorithm:

$$f_3(x, y, z) = A \frac{a^2}{\frac{a^2}{4} + x'^2 + y'^2} \cdot \left( e^{-\frac{2z}{a}} + \frac{a^2}{2(a + 2z)^2} \right)$$

## 2.2. Isotropic E-Field Probe

The isotropic E-Field probe has been fully calibrated and assessed for isotropic, and boundary effect within a controlled environment. Depending on the frequency for which the probe is calibrated the method utilized for calibration will change. A number of methods is used for calibrating probes, and these are outlined in the table below:

Calibration Frequency	Air Calibration	Tissue Calibration
900MHz	TEM Cell	Temperature
1800MHz	TEM Cell	Temperature

The E-Field probe utilizes a triangular sensor arrangement as detailed in the diagram below:

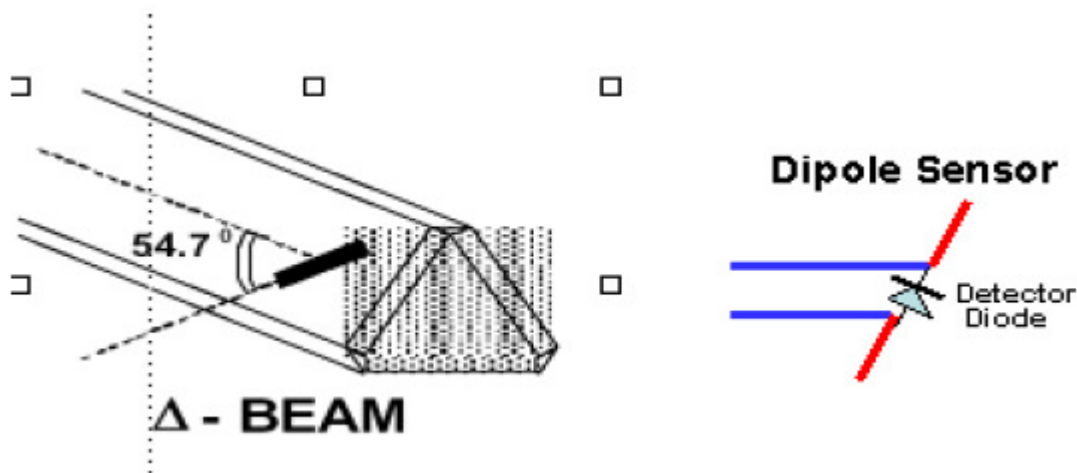

SAR is assessed with a calibrated probe which moves at a default height of 5mm from the center of the diode, which is mounted to the sensor, to the phantom surFront (in the Z Axis). The 5mm offset height has been selected so as to minimize any resultant boundary effect due to the probe being in close proximity to the phantom surFront.

The following algorithm is an example of the function used by the system for linearization of the output from the probe when measuring complex modulation schemes.

$$V_i = U_i + U_i^2 \cdot \frac{cf}{dcp_i}$$

### 2.2.1. Isotropic E-Field Probe Specification

<b>Calibration in Air</b>	Frequency Dependent Below 2GHz Calibration in air performed in a TEM Cell Above 2GHz Calibration in air performed in waveguide
<b>Sensitivity</b>	0.70 $\mu\text{V}/(\text{V}/\text{m})^2$ to 0.85 $\mu\text{V}/(\text{V}/\text{m})^2$
<b>Dynamic Range</b>	0.0005 W/kg to 100W/kg
<b>Isotropic Response</b>	Better than 0.2dB
<b>Diode Compression point (DCP)</b>	Calibration for Specific Frequency
<b>Probe Tip Radius</b>	< 5mm
<b>Sensor Offset</b>	1.56 (+/- 0.02mm)
<b>Probe Length</b>	290mm
<b>Video Bandwidth</b>	@ 500 Hz: 1dB @1.02 KHz: 3dB
<b>Boundary Effect</b>	Less than 2% for distance greater than 2.4mm
<b>Spatial Resolution</b>	Diameter less than 5mm Compliant with Standards

Probe model no: ALS-E-020, S/N:500-00273

### 2.3. Boundary detection Unit and Probe Mounting Device

ALSAS-10U incorporates a boundary detection unit with a sensitivity of 0.05mm for detecting all types of surFronts. The robust design allows for detecting during probe tilt (probe normalize) exercises, and utilizes a second stage emergency sTop. The signal electronics are directly into the robot controller for high accuracy surFront detection in lateral and axial detection modes (X, Y, &Z).

The probe is mounted directly onto the Boundary Detection unit for accurate tooling and displacement calculations controlled by the robot kinematics. The probe is connected to an isolated probe interconnect where the output stage of the probe is fed directly into the amplifier stage of the Daq-Paq.



## 2.4. Daq-Paq (Analog to Digital Electronics)

ALSAS-10U incorporates a fully calibrated Daq-Paq (analog to digital conversion system) which has a 4 channel input stage, sent via a 2 stage auto-set amplifier module. The input signal is amplified accordingly so as to offer a dynamic range from  $5 \mu\text{V}$  to 800mV. Integration of the fields measured is carried out at board level utilizing a Co-Processor which then sends the measured fields down into the main computational module in digitized form via a RS232 communications port. Probe linearity and duty cycle compensation is carried out within the main Daq-Paq module.

<b>ADC</b>	12 Bit
Amplifier Range	20mV to 200mV and 150mV to 800mV
Field Integration	Local Co-Processor utilizing proprietary integration algorithms
Number of Input Channels	4 in total 3 dedicated and 1 spare
Communication	Packet data via RS232

## 2.5. Axis Articulated Robot

ALSAS-10U utilizes a six articulated robot, which is controlled using a Pentium based real-time movement controller. The movement kinematics engine utilizes proprietary (Thermo CRS) interpolation and extrapolation algorithms, which allow full freedom of movement for each of the six joints within the working envelop. Utilization of joint 6 allows for full probe rotation with a tolerance better than 0.05mm around the central axis.



<b>Robot/Controller Manufacturer</b>	Thermo CRS
<b>Number of Axis</b>	Six independently controlled axis
<b>Positioning Repeatability</b>	0.05mm
<b>Controller Type</b>	Single phase Pentium based C500C
<b>Robot Reach</b>	710mm
<b>Communication</b>	RS232 and LAN compatible

## 2.6. ALSAS Universal Workstation

ALSAS Universal workstation allows for repeatability and fast adaptability. It allows users to do calibration, testing and measurement using different types of phantoms with one set up, which significantly speeds up the measurement process.

## 2.7. Universal Device Positioner

The universal device positioner allows complete freedom of movement of the EUT. Developed to hold a EUT in a free-space scenario any additional loading attributable to the material used in the construction of the positioner has been eliminated. Repeatability has been enhanced through the linear scales which form the design used to indicate positioning for any given test scenario in all major axes. A 15° tilt movements for head SAR analysis. Overall uncertainty for measurements has been reduced due to the design of the Universal device positioner, which allows positioning of a device in as near to a free-space scenario as possible, and by providing the means for complete repeatability.



## 2.8. Phantom Types

The ALSAS-10U allows the integration of multiple phantom types. SAM Phantoms fully compliant with IEEE 1528, Universal Phantom, and Universal Flat.

### 2.8.1. APREL SAM Phantoms

The SAM phantoms developed using the IEEE SAM CAD file. They are fully compliant with the requirements for both IEEE 1528 and FCC Supplement C. Both the left and right SAM phantoms are interchangeable, transparent and include the IEEE 1528 grid with visible NF and MB lines.

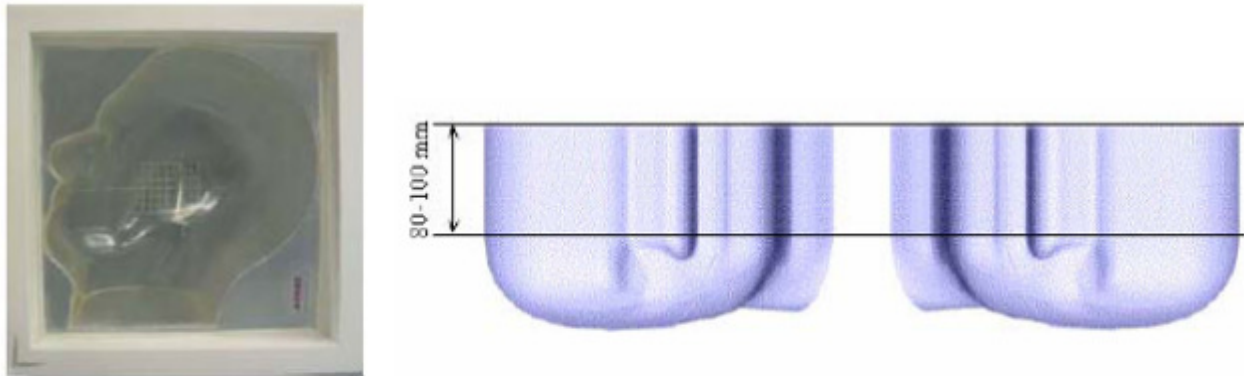

### 2.8.2. APREL Laboratories Universal Phantom

The Universal Phantom is used on the ALSAS-10U as a system validation phantom. The Universal Phantom has been fully validated both experimentally from 800MHz to 6GHz and numerically using XFDTD numerical software. The shell thickness is 2mm overall, with a 4mm spacer located at the NF/MB intersection providing an overall thickness of 6mm in line with the requirements of IEEE-1528.

The design allows for fast and accurate measurements, of handsets, by allowing the conservative SAR to be evaluated at on frequency for both left and right head experiments in one measurement.



### 3. Tissue Simulating Liquid

#### 3.1. The composition of the tissue simulating liquid

INGREDIENT (% Weight)	850MHz	1900MHz	850MHz	1900MHz
	Head	Head	Body	Body
Water	40.45%	54.9%	45.0%	70.17%
Salt	1.45%	0.18%	52.4%	0.39%
Sugar	57.6%	0%	1.4%	0%
HEC	0.4%	0%	1.0%	0%
Preventol	0.1%	0%	0.1%	0%
DGBE	0%	44.92%	0%	29.44%

#### 3.2. Tissue Calibration Result

The dielectric parameters of the liquids were verified prior to SAR evaluation using APREL Dielectric Probe Kit and Agilent E5071B Vector Network Analyzer.

Head Tissue Simulate Measurement				
Frequency (MHz)	Description	Dielectric Parameters		Tissue Temp.(°C)
		$\epsilon_r$	$\sigma$ (s/m)	
835MHz	Reference result	41.5	0.90	NA
	+/-5% window	39.425to43.575	0.855to0.945	
	17-Apr-13	40.37	0.93	20.7
1900MHz	Reference result	40.0	1.40	NA
	+/-5% window	38to42	1.33 to 1.47	
	17-Apr-13	41.55	1.42	20.7

Body Tissue Simulate Measurement				
Frequency (MHz)	Description	Dielectric Parameters		Tissue Temp.(°C)
		$\epsilon_r$	$\sigma$ (s/m)	
835MHz	Reference result	55.2	0.97	NA
	+/-5% window	52.44to57.96	0.922to1.019	
	17-Apr-13	53.32	0.96	20.7
1900MHz	Reference result	53.3	1.52	NA
	+/-5% window	50.635to55.965	1.444to1.596	
	17-Apr-13	52.93	1.51	20.7

### 3.3. Tissue Dielectric Parameters for Head and Body Phantoms

The head tissue dielectric parameters recommended by the IEEE SCC-34/SC-2 in PP1528 have been incorporated in the following table. These head parameters are derived from planar layer models simulating the highest expected SAR for the dielectric properties and tissue thickness variations in a human head. Other head and body tissue parameters that have not been specified in P1428 are derived from the tissue dielectric parameters computed from the 4-Cole-Cole equations described in Reference [12] and extrapolated according to the head parameters specified in P1528.

Target Frequency (MHz)	Head		Body	
	$\epsilon_r$	$\sigma$ (S/m)	$\epsilon_r$	$\sigma$ (S/m)
150	52.3	0.76	61.9	0.80
300	45.3	0.87	58.2	0.92
450	43.5	0.87	56.7	0.94
835	41.5	0.90	55.2	0.97
900	41.5	0.97	55.0	1.05
915	41.5	0.98	55.0	1.06
1450	40.5	1.20	54.0	1.30
1610	40.3	1.29	53.8	1.40
1800 – 2000	40.0	1.40	53.3	1.52
2450	39.2	1.80	52.7	1.95
3000	38.5	2.40	52.0	2.73
5800	35.3	5.27	48.2	6.00

( $\epsilon_r$ =relative permittivity,  $\sigma$ =conductivity and  $\rho=1000 \text{ kg/m}^3$ )

**4. SAR Measurement Procedure**

4.1. SAR System Validation

**4.1.1. Validation Dipoles**

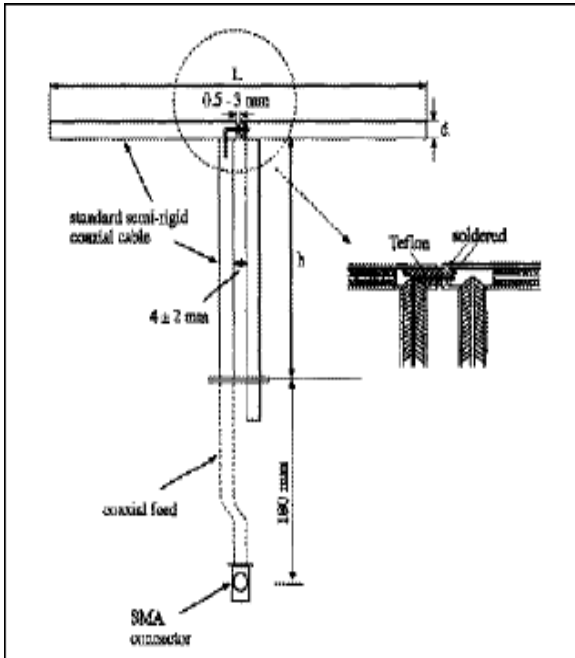

The dipoles used are based on the IEEE-1528 standard, and is complied with mechanical and electrical specifications in line with the requirements of both IEEE and FCC Supplement C. The table below provides details for the mechanical and electrical specifications for the dipoles.

Frequency	L(mm)	h(mm)	d(mm)
835MHz	161	89.8	3.6
1900MHz	67.1	38.9	3.6

## 4.1.2. Validation Result

Head System Performance Check at 835MHz&1900MHz				
Validation Kit: ASL-D-835-S-2				
Frequency(MHz)	Description	SAR(W/kg) 1g	SAR(W/kg) 10g	Tissue Temp.(°C)
835MHz	Reference result	9.590	6.003	N/A
	+/-5%window	9.110to10.07	5.702to6.303	
	17-Apr-13(1W)	9.498	5.877	20.7
Validation Kit: ASL-D-1900-S-2				
Frequency(MHz)	Description	SAR(W/kg) 1g	SAR(W/kg) 10g	Tissue Temp.(°C)
1900MHz	Reference result	39.378	19.668	N/A
	+/-5%window	37.418to41.356	18.685to20.651	
	17-Apr-13(1W)	38.694	19.256	20.7
Note: All SAR values are normalized to 1 W forward power.				

Body System Performance Check at 835MHz&1900MHz				
Validation Kit: ASL-D-835-S-2				
Frequency(MHz)	Description	SAR(W/kg) 1g	SAR(W/kg) 10g	Tissue Temp.(°C)
835MHz	Reference result	9.981	6.006	N/A
	+/-5%window	9.482to10.48	5.706to6.306	
	17-Apr-13(1W)	9.559	5.883	20.7
Validation Kit: ASL-D-1900-S-2				
Frequency(MHz)	Description	SAR(W/kg) 1g	SAR(W/kg) 10g	Tissue Temp.(°C)
1900MHz	Reference result	39.654	19.668	N/A
	+/-5%window	37.671to41.637	18.685to20.651	
	17-Apr-13(1W)	39.649	19.731	20.7
Note: All SAR values are normalized to 1W forward power.				

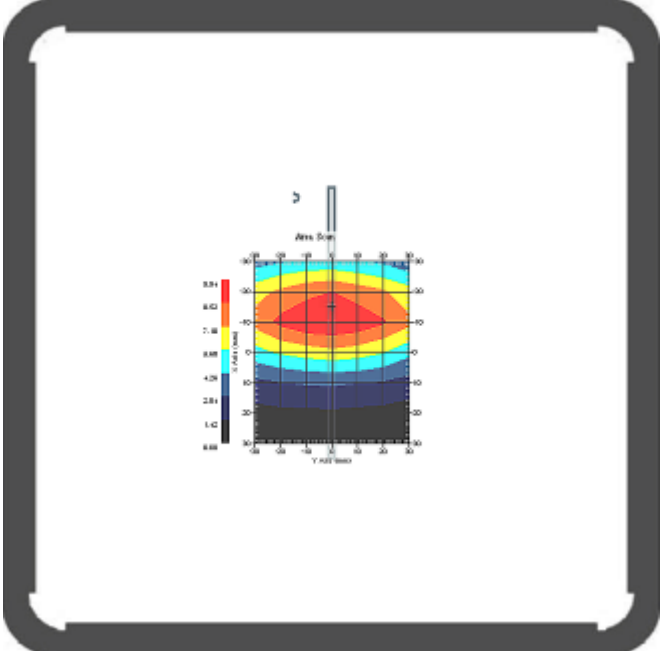
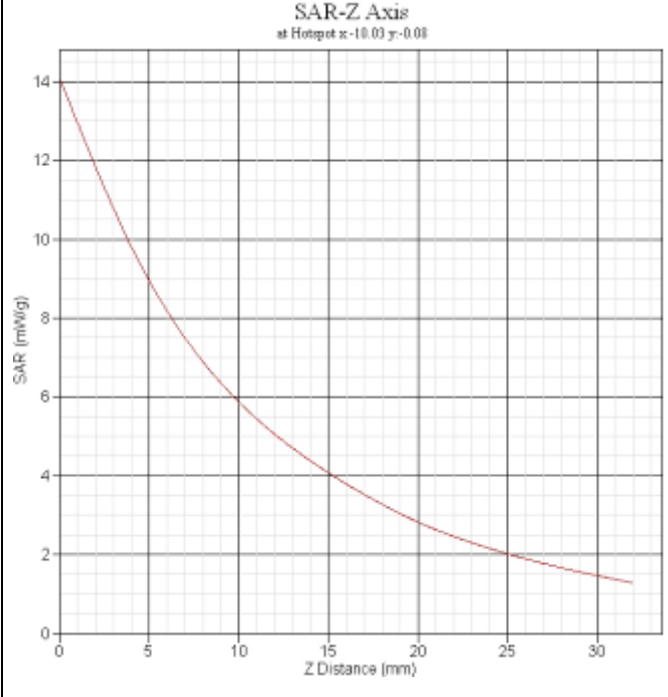

Frequency(MHz)	835
Relative permittivity(real part)	40.37
Conductivity(S/m)	0.93
Variation(%)	0.532
Duty Cycle Factor	1
Crest factor	1
Conversion Factor	6.5
Probe Sensitivity	1.20 1.20 1.20 $\mu$ V/(V/m) <sup>2</sup>
Data	2013-04-17
	
SAR 1g(W/kg)	9.498
SAR 10g(W/kg)	5.877

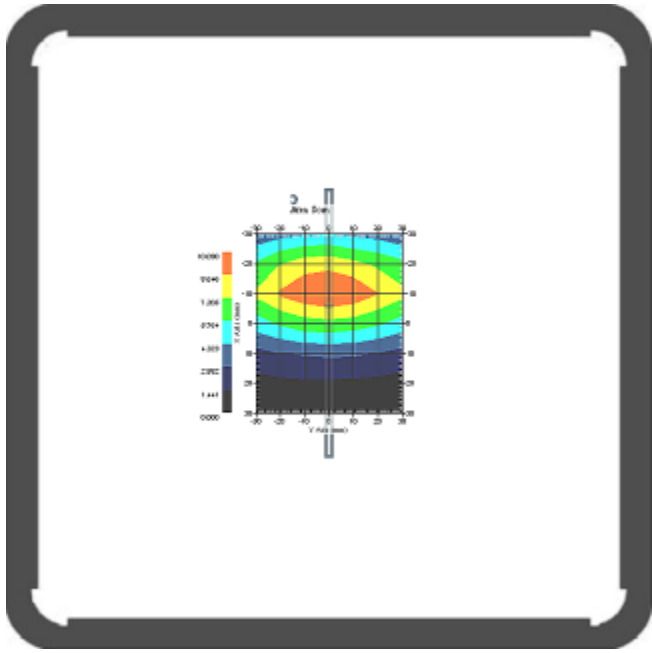
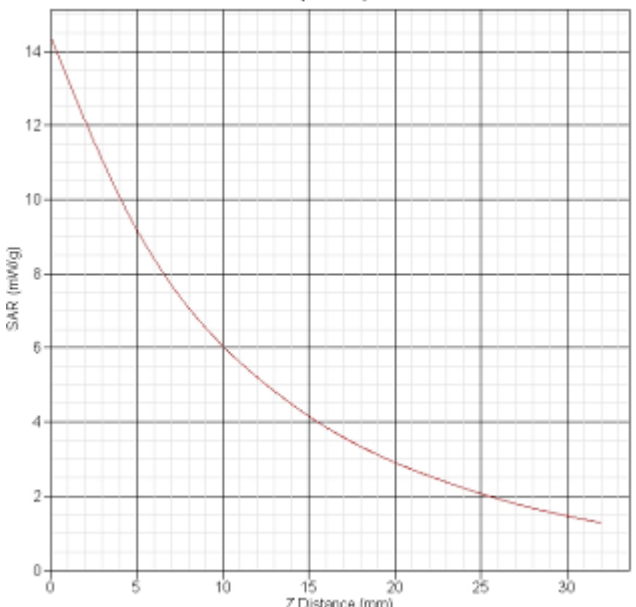
Frequency(MHz)	835
Relative permittivity(real part)	53.32
Conductivity(S/m)	0.96
Variation(%)	-0.531
Duty Cycle Factor	1
Crest factor	1
Conversion Factor	6.4
Probe Sensitivity	1.20 1.20 1.20 $\mu V/(V/m)^2$
Data	2013-04-17
	<p>SAR-Z Axis at Hotspot x:-9.96 y:-0.13</p> 
SAR 1g(W/kg)	9.559
SAR 10g(W/kg)	5.883

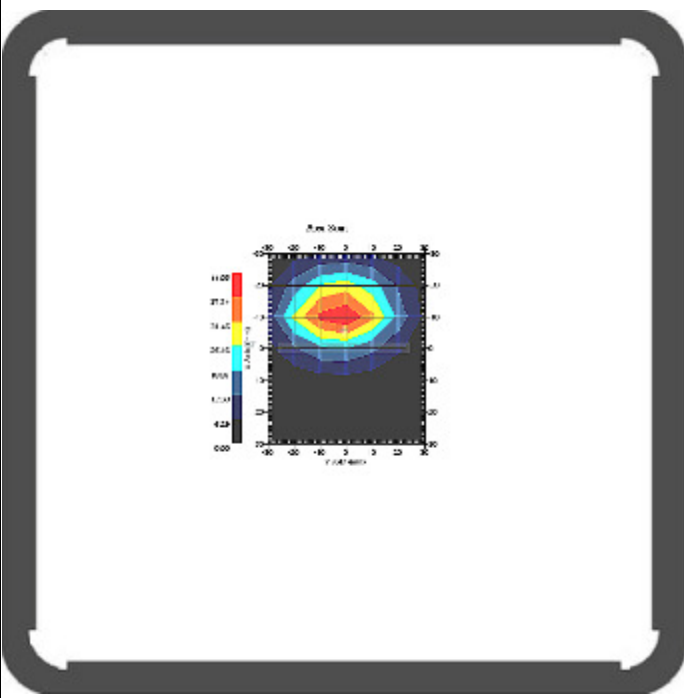
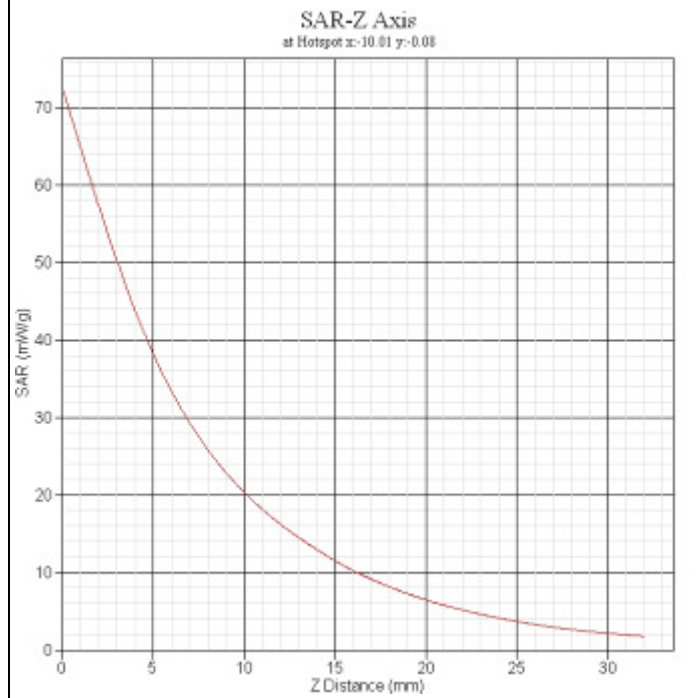
Frequency(MHz)	1900
Relative permittivity(real part)	41.55
Conductivity(S/m)	1.42
Variation(%)	0.268
Duty Cycle Factor	1
Crest factor	1
Conversion Factor	5.7
Probe Sensitivity	1.20 1.20 1.20 $\mu V/(V/m)^2$
Data	2013-04-17
	
SAR 1g(W/kg)	38.694
SAR 10g(W/kg)	19.256

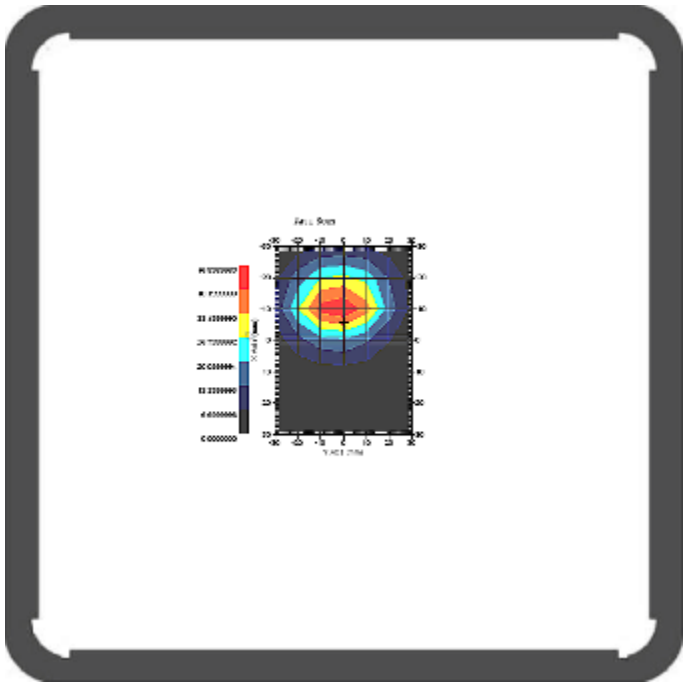
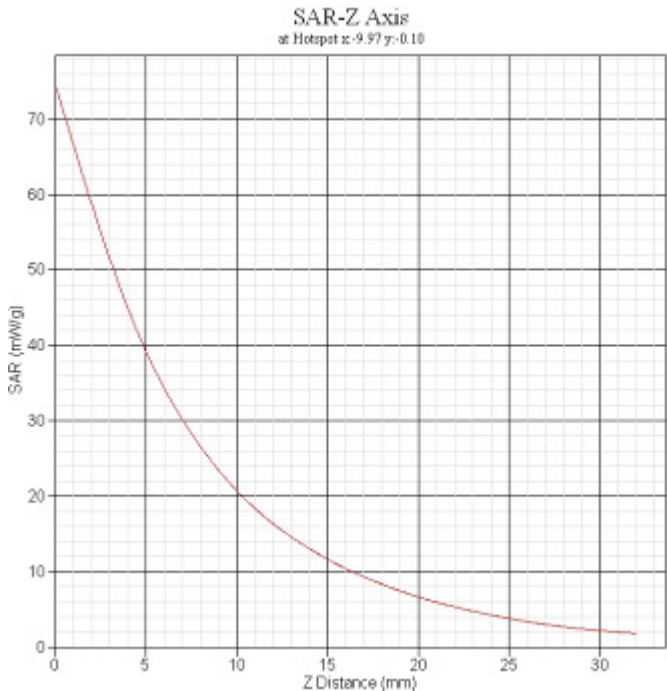
Frequency(MHz)	1900
Relative permittivity(real part)	52.93
Conductivity(S/m)	1.51
Variation(%)	-0.156
Duty Cycle Factor	1
Crest factor	1
Conversion Factor	5.4
Probe Sensitivity	1.20 1.20 1.20 $\mu V/(V/m)^2$
Data	2013-04-17
	
SAR 1g(W/kg)	39.649
SAR 10g(W/kg)	19.731

## 4.2. Arrangement Assessment Setup

### 4.2.1. Test Positions of Device Relative to Head

This specifies exactly two test positions for the handset against the head phantom, the “cheek” position and the “tilted” position. The handset should be tested in both positions on the left and right sides of the SAM phantom. If the handset construction is such that it cannot be positioned using the handset positioning procedures described in 4.2.2.1 and 4.2.2.2 to represent normal use conditions (e.g. asymmetric handset), alternative alignment procedures should be considered with details provided in the test report.

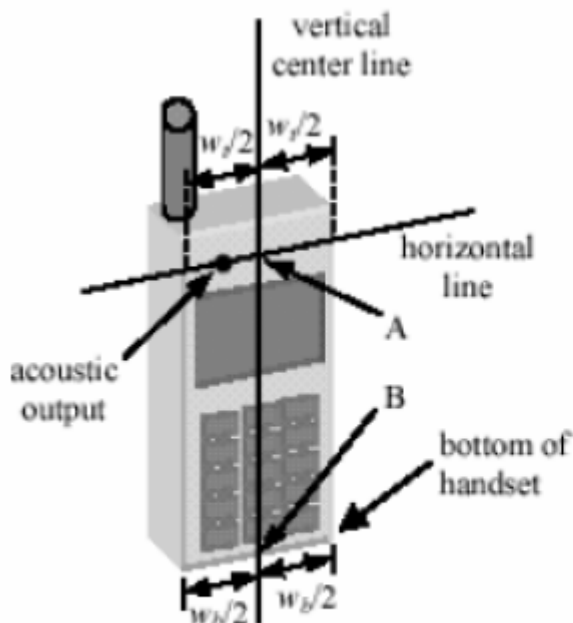

Figure 4.1a Internal Case

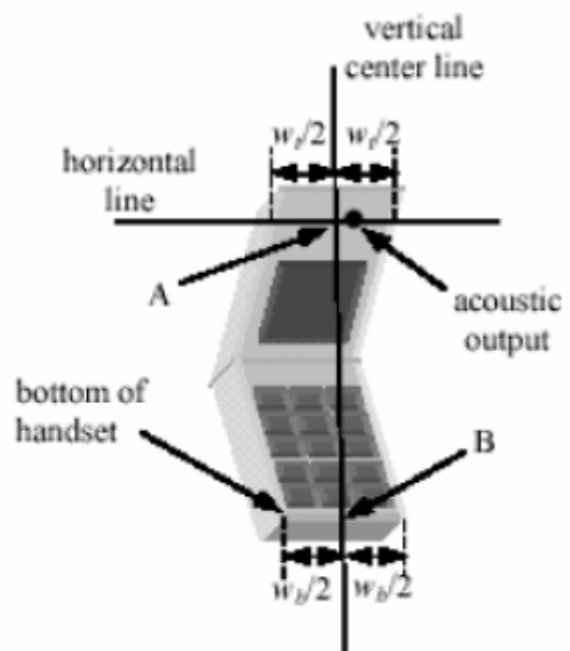

Figure 4.1b Clam Shell

#### 4.2.2.1. Definition of the “Cheek” Position

The “cheek” position is defined as follows:

- Ready the handset for talk operation, if necessary. For example, for hand sets with a cover piece, open the cover. (If the handset can also be used with the cover closed both configurations must be tested.)
- Define two imaginary lines on the handset: the vertical centerline and the horizontal line. The vertical centerline passes through two points on the front side of the handset: the midpoint of the width  $w_t$  of the handset at the level of the acoustic output (point A on Figures 4.1 a and 4.1 b), and the midpoint of the width  $w_b$  of the Back of the handset through the center of the acoustic output (see Figure 4.1 a). The

- two lines intersect at point A. Note that for many handsets, point A coincides with the center of the acoustic output. However, the acoustic output may be located elsewhere on the horizontal line. Also note that the vertical centerline is not necessarily parallel to the front of the handset (see Figure 4.1 b), especially for clamshell handsets, handsets with flip pieces, and other irregularly-shaped handsets.
- Position the handset close to the surface of the phantom such that point A is on the (virtual) extension of the line passing through points RE and LE on the phantom (see 4.2), such that the plan defined by the vertical center line and the horizontal line of the handset is approximately parallel to the sagittal plane of the phantom.
  - Translate the handset towards the phantom along the line passing through RE and LE until the handset touches the pinna.
  - While maintaining the handset in this plane, rotate it around the LE-RE line until the vertical centerline is in the plane normal to MB-NF including the line MB (called the reference plane).
  - Rotate the handset around the vertical centerline until the handset (horizontal line) is symmetrical with respect to the line NF.

While maintaining the vertical centerline in the reference plane, keeping point A on the line passing through RE and LE and maintaining the handset contact with the pinna, rotate the handset about the line NF until any point on the handset is in contact with a phantom point below the pinna (cheek). See Figure 4.2 the physical angles of rotation should be noted.

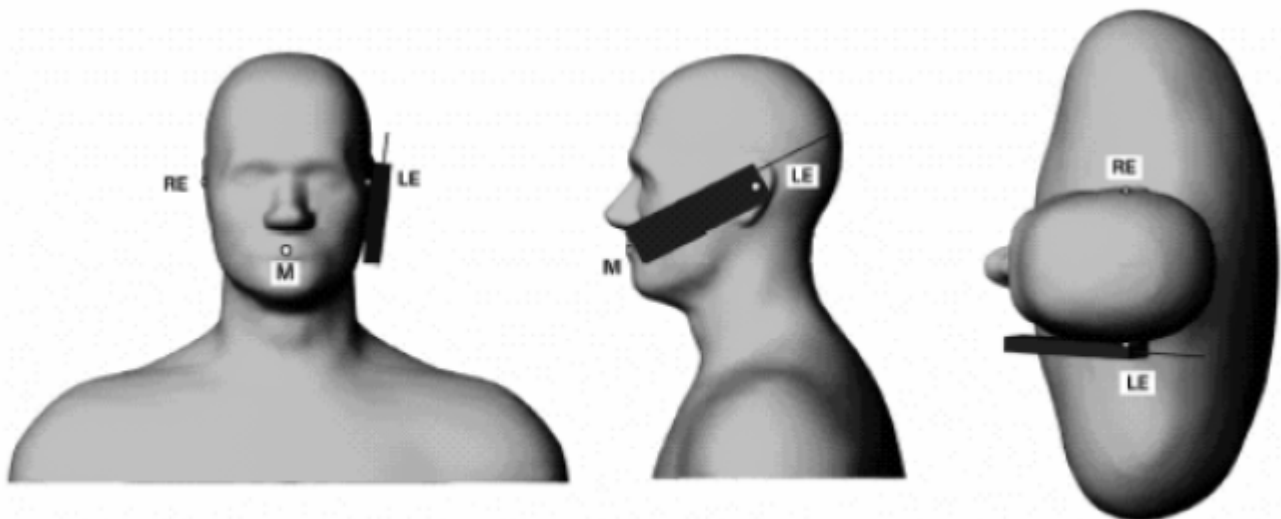

Figure 4.2 – Phone position 1, “cheek” or “touch” position.

#### 4.2.1.2 Definition of the “Tilted” Position

The “tilted” position is defined as follows:

- Repeat steps (a) – (g) of 4.2.1.1 to place the device in the “cheek position”.
- While maintaining the orientation of the handset move the handset away from the pinna along the line passing through RE and LE in order to enable a rotation of the

handset by 15 degrees.

c. Rotate the handset around the horizontal line by 15 degrees.

d. While maintaining the orientation of the handset, move the handset towards the phantom on a line passing through RE and LE until any part of the handset touches the ear. The tilted position is obtained when the contact is on the pinna. If the contact is at any location other than the pinna (e.g. the antenna with the Back of the phantom head), the angle of the handset should be reduced. In this case, the tilted position is obtained if any part of the handset is in contact with the pinna as well as a second part of the handset is contact with the phantom (e.g. the antenna with Back of the head).

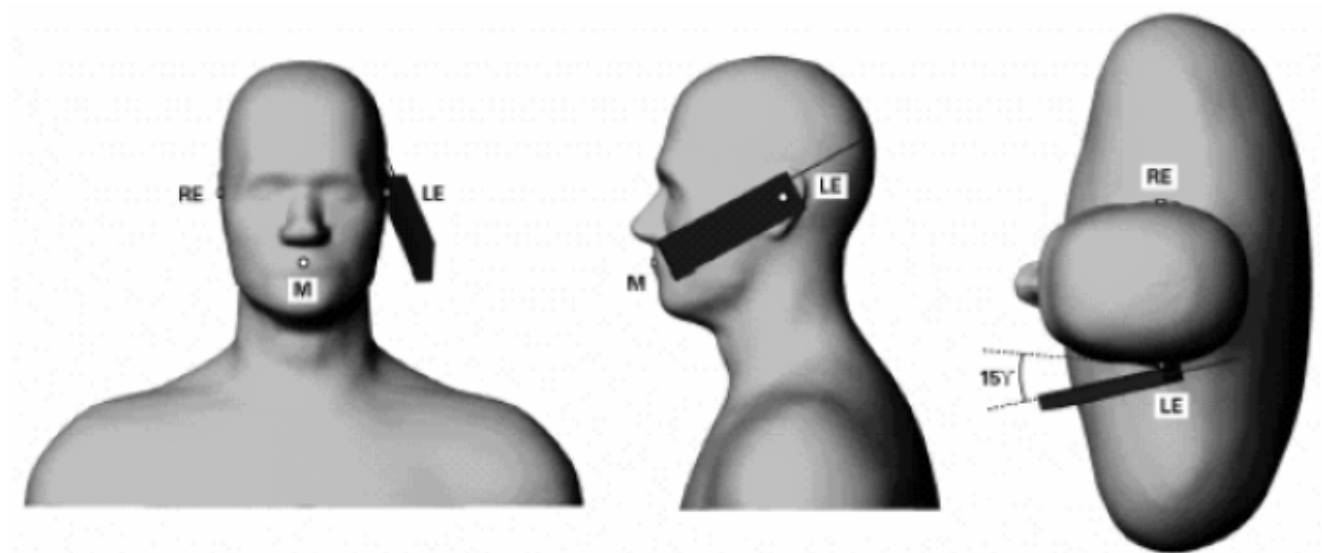

Figure 4.3 – Phone position 2, "tilted" position.

#### 4.2.2. Test Positions for body-worn

Body-worn operating configurations should be tested with the belt-clips and holsters attached to the device and positioned against a flat phantom in normal use configurations. A separation distance of 1.5 cm between the Back of the device and a flat phantom is recommended for testing body-worn SAR compliance under such circumstances. Other separation distance may be use, but not exceed 2.5cm.

#### 4.3. SAR Measurement Procedure

The ALSAS-10U calculates SAR using the following equation,

$$SAR = \frac{\sigma |E|^2}{\rho}$$

$\sigma$  :represents the simulated tissue conductivity

$\rho$  :represents the tissue density

The EUT is set to transmit at the required power in line with product specification, at each frequency relating to the LOW, MID, and HIGH channel settings.

Pre-scans are made on the device to establish the location for the transmitting antenna, using a large area scan in either air or tissue simulation fluid.

The EUT is placed against the Universal Phantom where the maximum area scan dimensions are large than the physical size of the resonating antenna. When the scan size is not large enough to cover the peak SAR distribution, it is modified by either extending the area scan size in both the X and Y directions, or the device is shifted within the predefined area.

The area scan is then run to establish the peak SAR location (interpolated resolution set at 1 mm<sup>2</sup>) which is then used to orient the center of the zoom scan. The zoom scan is then executed and the 1g and 10g averages are derived from the zoom scan volume (interpolated resolution set at 1 mm<sup>3</sup>).

## 5. SAR Exposure Limits

SAR assessments have been made in line with the requirements of IEEE C95.1-1999, IEEE 1528-2003 , FCC OET Bulletin 65 supplement C.

Type Exposure (W/kg)	Uncontrolled Environment Limit
Spatial Peak SAR (10g cube tissue for head and trunk)	1.60 W/kg
Spatial Average SAR (whole body)	0.08 W/kg
Spatial Peak SAR (10g for limb)	4.00 W/kg



**6. Test Equipment List**

Instrument	Manufacture	Model No.	Serial No.	Last Calibration
Universal Work Station	Aprl	ALS-UWS	100-00154	NCR
Data Acquisition Package	Aprl	ALS-DAQ-PAQ-3	110-00215	NCR
Probe Mounting Device and Boundary Detection Sensor System	Aprl	ALS-PMDPS-3	120-00265	NCR
Miniature E-Field Probe	Aprl	ALS-E-020	500-00273	Oct.01,2012
Left ear SAM Phantom	Aprl	ALS-P-SAM-L	130-00312	NCR
Right ear SAM Phantom	Aprl	ALS-P-SAM-R	140-00362	NCR
Universal SAM Phantom	Aprl	ALS-P-SU-1	150-00410	NCR
Reference Validation Dipole 850MHz	Aprl	ALS-D-835-S-2	180-00556	May.19,2011
Reference Validation Dipole 1900MHz	Aprl	ALS-D-1900-S-2	210-00707	May.16,2011
Dielectric Probe Kit	Aprl	ALS-PR-DIEL	260-00955	NCR
Device Holder 2.0	Aprl	ALS-H-E-SET-2	170-00506	NCR
SAR software	Aprl	ALS-SAR-AL-10	Ver.2.3.8	NCR
CRS C500C Controller	Thermo	ALS-C500	RCF0504291	NCR
CRS F3 Robot	Aprl	ALS-F3-SW	N/A	NCR
Power Amplifier	Mini-Circuit	ZHL- 42	040306	Jul.17,2012
Directional Coupler	Agilent	778D-012	51011	Jul.17,2012
Universal Radio Communication Tester	Agilent	E5515C	104845	Mar.1,2013
Vector Network	Agilent	E5071B	MY4230146	Jul.19,2012
Signal Generator	Agilent	E8257D	N/A	Dec.10,2012
Power Meter	Rohde&Schwarz	NRP	N/A	Dec.10,2012

**Note:** All equipment upon which need to be calibrated are with calibration period of 1 year, except validation dipole antenna of every 3 years.

## 7. Measurement Uncertainty

### Exposure Assessment Measurement Uncertainty

Source of Uncertainty	Tolerance Value	Probability Distribution	Divisor	$c_i^1$ (1-g)	$c_i^1$ (10-g)	Standard Uncertainty (1-g) %	Standard Uncertainty (10-g) %
Measurement System							
Probe Calibration	3.5	normal	1	1	1	3.5	3.5
Axial Isotropy	3.7	rectangular	$\sqrt{3}$	$(1-cp)^{1/2}$	$(1-cp)^{1/2}$	1.5	1.5
Hemispherical Isotropy	10.9	rectangular	$\sqrt{3}$	$\sqrt{cp}$	$\sqrt{cp}$	4.4	4.4
Boundary Effect	1.0	rectangular	$\sqrt{3}$	1	1	0.6	0.6
Linearity	4.7	rectangular	$\sqrt{3}$	1	1	2.7	2.7
Detection Limit	1.0	rectangular	$\sqrt{3}$	1	1	0.6	0.6
Readout Electronics	1.0	normal	1	1	1	1.0	1.0
Response Time	0.8	rectangular	$\sqrt{3}$	1	1	0.5	0.5
Integration Time	1.7	rectangular	$\sqrt{3}$	1	1	1.0	1.0
RF Ambient Condition	3.0	rectangular	$\sqrt{3}$	1	1	1.7	1.7
Probe Positioner Mech.	0.4	rectangular	$\sqrt{3}$	1	1	0.2	0.2
Restriction							
Probe Positioning with respect to Phantom Shell	2.9	rectangular	$\sqrt{3}$	1	1	1.7	1.7
Extrapolation and Integration	3.7	rectangular	$\sqrt{3}$	1	1	2.1	2.1
Test Sample Positioning	4.0	normal	1	1	1	4.0	4.0
Device Holder Uncertainty	2.0	normal	1	1	1	2.0	2.0
Drift of Output Power	0.6	rectangular	$\sqrt{3}$	1	1	0.3	0.3
Phantom and Setup							
Phantom Uncertainty(shape & thickness tolerance)	3.4	rectangular	$\sqrt{3}$	1	1	2.0	2.0
Liquid Conductivity(target)	5.0	rectangular	$\sqrt{3}$	0.7	0.5	2.0	1.4
Liquid Conductivity(meas.)	0.0	normal	1	0.7	0.5	0.0	0.0

Liquid Permittivity(target)	5.0	rectangular	$\sqrt{3}$	0.6	0.5	1.7	1.4
Liquid Permittivity(meas.)	2.4	normal	1	0.6	0.5	1.4	1.2
Combined Uncertainty		RSS				9.3	9.2
Combined Uncertainty (coverage factor=2)		Normal (k=2)				18.7	18.3

## 8. SAR Test Results

### 8.1. Conducted Power(Unit:dBm)

Band	GSM850			GSM1900		
	128	190	251	512	661	810
Frequency(MHz)	824.2	836.6	848.8	1850.2	1900.0	1909.8
GSM	32.14	<b>32.23</b>	32.18	<b>29.74</b>	29.69	29.53
GPRS (1UP)	32.13	32.22	32.16	29.73	29.66	29.52
GPRS (2UP)	31.47	31.64	31.53	28.65	28.58	28.47

### 8.2. SAR Test Results Summary

#### 8.2.1 Test results for Head SAR Test

Band	Position	Channel	Measured Power(dBm)	Tune-up Power(dBm)	SAR 1g (W/kg)	Scale factor	Scaled SAR 1g(W/kg)
GSM850	LC	190	32.23	33	0.177	1.194	0.211
	LT	190	32.23	33	0.152	1.194	0.181
	RC	190	32.23	33	0.206	1.194	0.246
	RT	190	32.23	33	0.148	1.194	0.177
GSM1900	LC	512	29.74	30	0.464	1.062	0.493
	LT	512	29.74	30	0.126	1.062	0.134
	RC	512	29.74	30	0.399	1.062	0.424
	RT	512	29.74	30	0.140	1.062	0.149

**8.2.2 Test results for Body-worn SAR Test**

Band	Position	CH	Measured Power(dBm)	Tune-up Power(dBm)	SAR 1g (W/kg)	Scale factor	Scaled SAR 1g(W/kg)
GSM850	Front	190	31.64	33	0.272	1.368	0.372
	Back	190	31.64	33	0.402	1.368	0.550
GSM1900	Front	512	28.65	30	0.166	1.365	0.227
	Back	512	28.65	30	0.269	1.365	0.367

Note :

1. Per KDB 865664 D01v01,for each frequency band, repeated SAR measurement is required only when the measured SAR is $\geq$ 0.8W/kg
2. Per KDB 447498D01v05, for each exposure position, if the highest output channel $<$ 0.8W/kg, other channels SAR testing are not necessary.
3. Per KDB 865664 D01v01,if the deviation among the repeated measurement is $\leq$ 20% and the measured SAR $<$ 1.45W/kg, only one repeated measurement is required.
4. The deviation is the difference in percentage between original and repeated measured SAR.
5. All measurement SAR result is scaled-up to account for tune-up tolerance and is compliant.

8.3. SAR Measurement Data

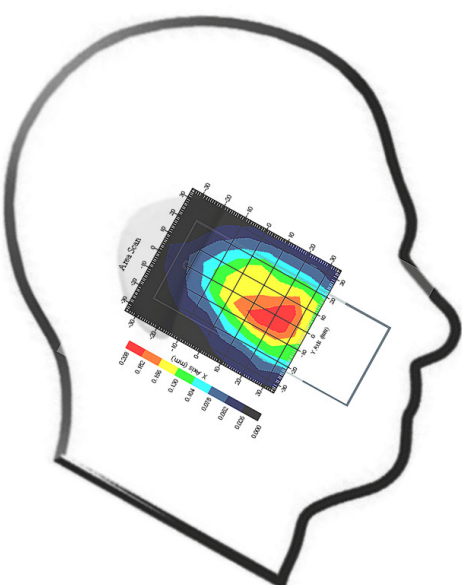
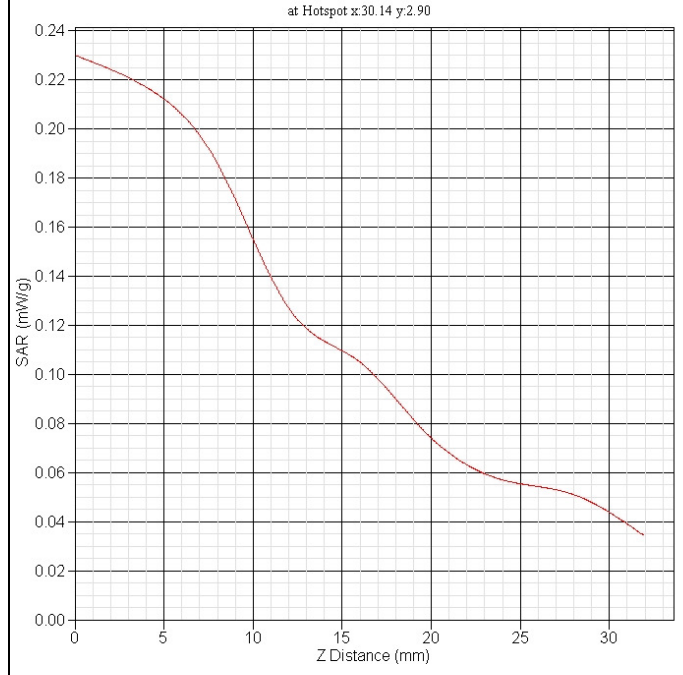
<b>GSM850 left cheek ch190</b>																			
Frequency(MHz)	836.6																		
Relative permittivity(real part)	40.37																		
Conductivity(S/m)	0.93																		
Variation(%)	-1.103																		
Duty Cycle Factor	8																		
Crest factor	8																		
4Conversion Factor	6.5																		
Probe Sensitivity	1.20 1.20 1.20 $\mu V/(V/m)^2$																		
Data	2013-04-17																		
	<p>SAR-Z Axis at Hotspot x:30.14 y:2.90</p>  <table border="1"> <caption>SAR-Z Axis Data</caption> <thead> <tr> <th>Z Distance (mm)</th> <th>SAR (mW/kg)</th> </tr> </thead> <tbody> <tr><td>0</td><td>0.23</td></tr> <tr><td>5</td><td>0.21</td></tr> <tr><td>10</td><td>0.16</td></tr> <tr><td>15</td><td>0.11</td></tr> <tr><td>20</td><td>0.07</td></tr> <tr><td>25</td><td>0.05</td></tr> <tr><td>30</td><td>0.04</td></tr> <tr><td>32</td><td>0.03</td></tr> </tbody> </table>	Z Distance (mm)	SAR (mW/kg)	0	0.23	5	0.21	10	0.16	15	0.11	20	0.07	25	0.05	30	0.04	32	0.03
Z Distance (mm)	SAR (mW/kg)																		
0	0.23																		
5	0.21																		
10	0.16																		
15	0.11																		
20	0.07																		
25	0.05																		
30	0.04																		
32	0.03																		
SAR 1g(W/kg)	0.177																		
SAR 10g(W/kg)	0.111																		

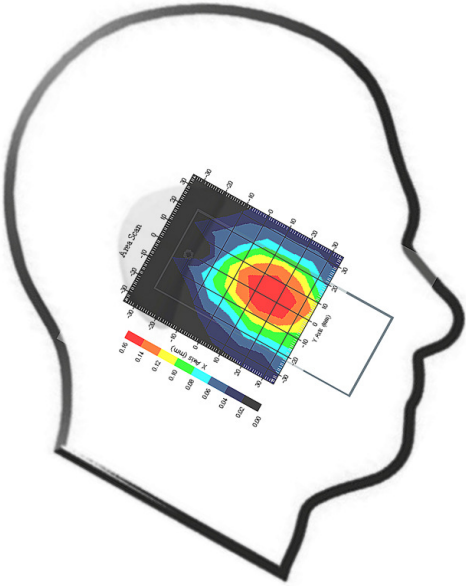
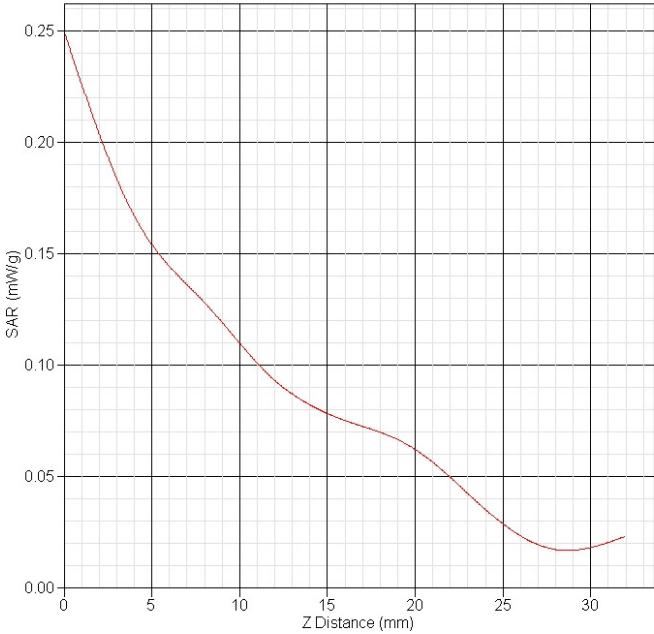
<b>GSM850 left tilt ch190</b>																	
Frequency(MHz)	836.6																
Relative permittivity(real part)	40.37																
Conductivity(S/m)	0.93																
Variation(%)	1.300																
Duty Cycle Factor	8																
Crest factor	8																
Conversion Factor	6.5																
Probe Sensitivity	1.20 1.20 1.20 $\mu V/(V/m)^2$																
Data	2013-04-17																
	<p>SAR-Z Axis at Hotspot x:30.19 y:4.83</p>  <table border="1"> <caption>SAR-Z Axis Data</caption> <thead> <tr> <th>Z Distance (mm)</th> <th>SAR (mW/g)</th> </tr> </thead> <tbody> <tr><td>0</td><td>0.25</td></tr> <tr><td>5</td><td>0.15</td></tr> <tr><td>10</td><td>0.10</td></tr> <tr><td>15</td><td>0.07</td></tr> <tr><td>20</td><td>0.05</td></tr> <tr><td>25</td><td>0.03</td></tr> <tr><td>30</td><td>0.02</td></tr> </tbody> </table>	Z Distance (mm)	SAR (mW/g)	0	0.25	5	0.15	10	0.10	15	0.07	20	0.05	25	0.03	30	0.02
Z Distance (mm)	SAR (mW/g)																
0	0.25																
5	0.15																
10	0.10																
15	0.07																
20	0.05																
25	0.03																
30	0.02																
SAR 1g(W/kg)	0.152																
SAR 10g(W/kg)	0.098																

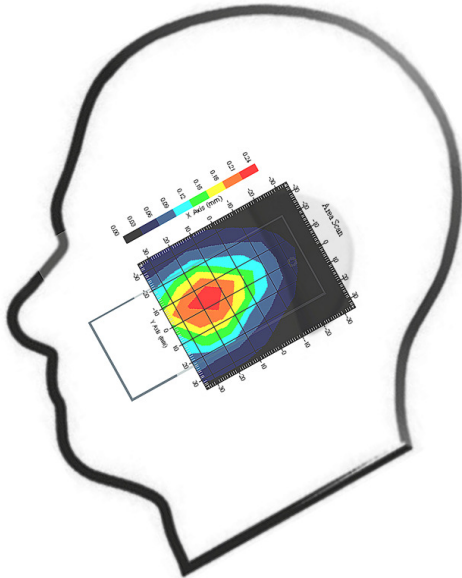
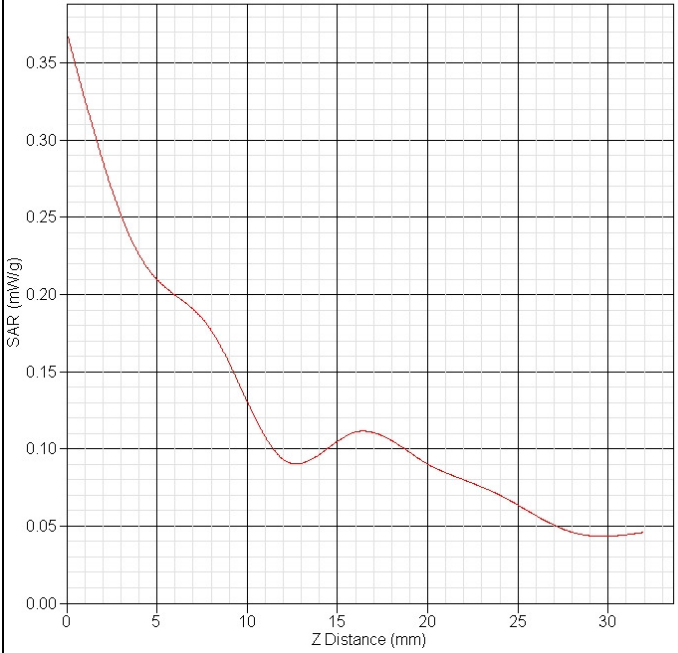
<b>GSM850 Right cheek ch190</b>	
Frequency(MHz)	836.6
Relative permittivity(real part)	40.37
Conductivity(S/m)	0.93
Variation(%)	3.821
Duty Cycle Factor	8
Crest factor	8
Conversion Factor	6.5
Probe Sensitivity	1.20 1.20 1.20 $\mu V/(V/m)^2$
Data	2013-04-17
	<p>SAR-Z Axis at Hotspot x:30.13 y:-4.91</p> 
SAR 1g(W/kg)	0.206
SAR 10g(W/kg)	0.123

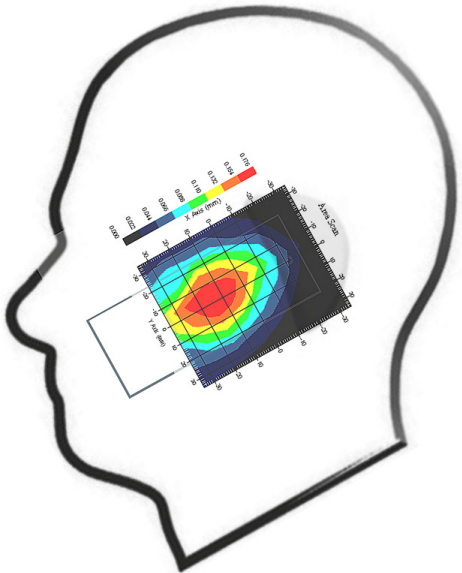
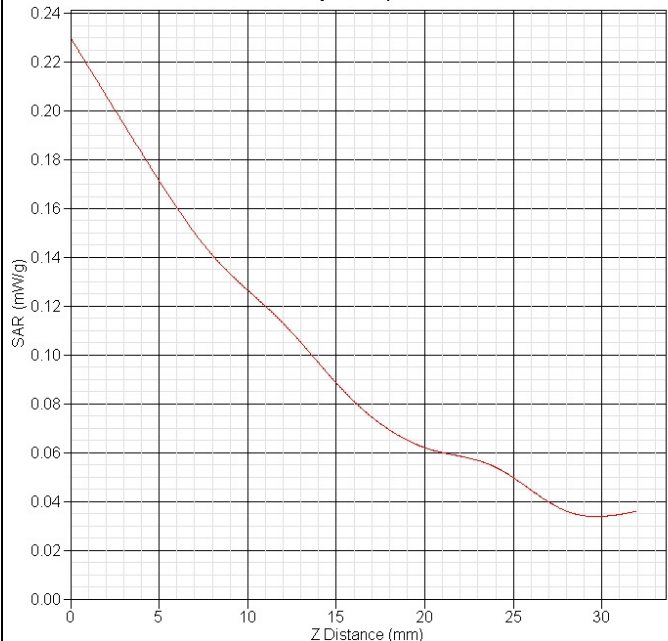
<b>GSM850 Right tilt CH190</b>																	
Frequency(MHz)	836.6																
Relative permittivity(real part)	40.37																
Conductivity(S/m)	0.93																
Variation(%)	-2.537																
Duty Cycle Factor	8																
Crest factor	8																
Conversion Factor	6.5																
Probe Sensitivity	1.20 1.20 1.20 $\mu V/(V/m)^2$																
Data	2013-04-17																
	<p>SAR-Z Axis at Hotspot x:30.11 y:-4.92</p>  <table border="1"> <caption>SAR-Z Axis Data Points (Estimated)</caption> <thead> <tr> <th>Z Distance (mm)</th> <th>SAR (mW/kg)</th> </tr> </thead> <tbody> <tr><td>0</td><td>0.23</td></tr> <tr><td>5</td><td>0.17</td></tr> <tr><td>10</td><td>0.12</td></tr> <tr><td>15</td><td>0.08</td></tr> <tr><td>20</td><td>0.06</td></tr> <tr><td>25</td><td>0.045</td></tr> <tr><td>30</td><td>0.035</td></tr> </tbody> </table>	Z Distance (mm)	SAR (mW/kg)	0	0.23	5	0.17	10	0.12	15	0.08	20	0.06	25	0.045	30	0.035
Z Distance (mm)	SAR (mW/kg)																
0	0.23																
5	0.17																
10	0.12																
15	0.08																
20	0.06																
25	0.045																
30	0.035																
SAR 1g(W/kg)	0.148																
SAR 10g(W/kg)	0.097																

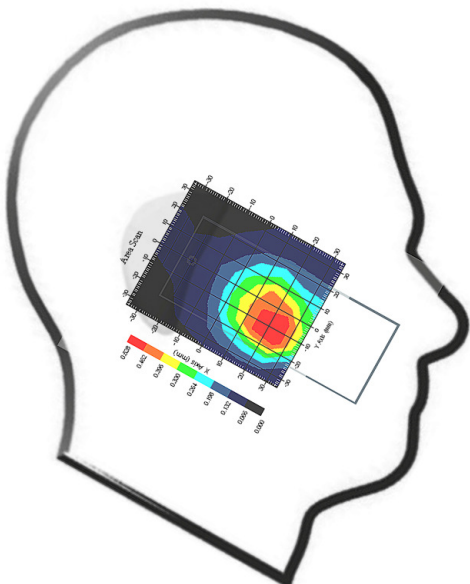
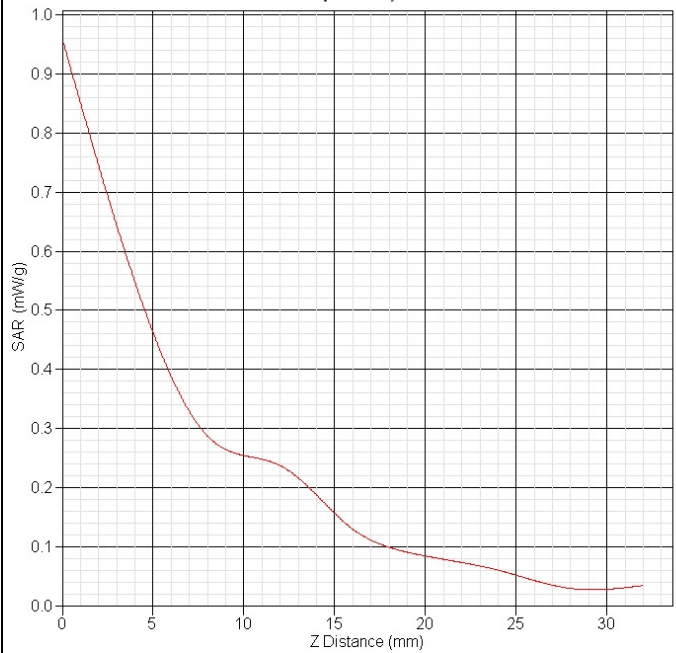

<b>GSM1900 Left cheek CH512</b>																	
Frequency(MHz)	1850.2																
Relative permittivity(real part)	41.55																
Conductivity(S/m)	1.42																
Variation(%)	-3.147																
Duty Cycle Factor	8																
Crest factor	8																
Conversion Factor	5.7																
Probe Sensitivity	1.20 1.20 1.20 $\mu V/(V/m)^2$																
Data	2013-04-17																
	<p>SAR-Z Axis at Hotspot x:40.16 y:-7.14</p>  <table border="1"> <caption>SAR-Z Axis Data</caption> <thead> <tr> <th>Z Distance (mm)</th> <th>SAR (mW/g)</th> </tr> </thead> <tbody> <tr><td>0</td><td>0.95</td></tr> <tr><td>5</td><td>0.45</td></tr> <tr><td>10</td><td>0.25</td></tr> <tr><td>15</td><td>0.15</td></tr> <tr><td>20</td><td>0.10</td></tr> <tr><td>25</td><td>0.07</td></tr> <tr><td>30</td><td>0.05</td></tr> </tbody> </table>	Z Distance (mm)	SAR (mW/g)	0	0.95	5	0.45	10	0.25	15	0.15	20	0.10	25	0.07	30	0.05
Z Distance (mm)	SAR (mW/g)																
0	0.95																
5	0.45																
10	0.25																
15	0.15																
20	0.10																
25	0.07																
30	0.05																
SAR 1g(W/kg)	0.464																
SAR 10g(W/kg)	0.233																

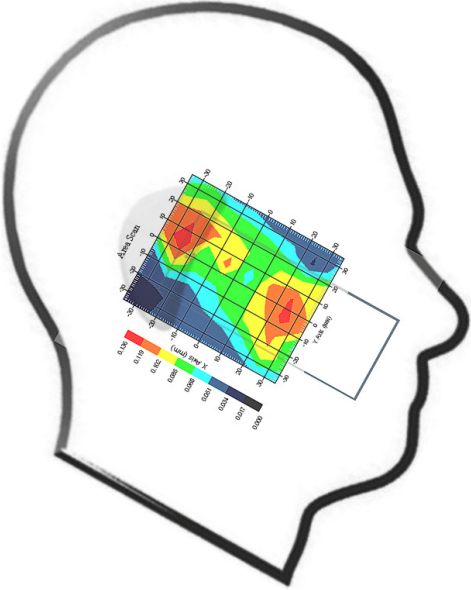
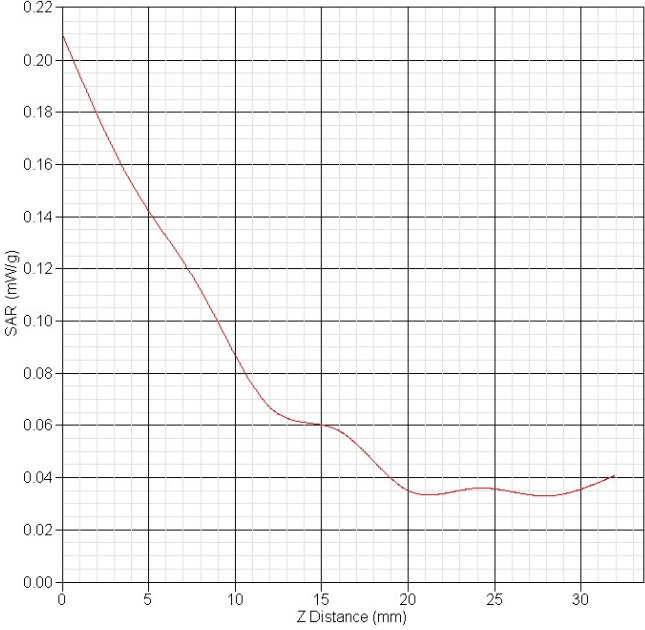
<b>GSM1900 Left tilt CH512</b>	
Frequency(MHz)	1850.2
Relative permittivity(real part)	41.55
Conductivity(S/m)	1.42
Variation(%)	1.625
Duty Cycle Factor	8
Crest factor	8
Conversion Factor	5.7
Probe Sensitivity	1.20 1.20 1.20 $\mu V/(V/m)^2$
Data	2013-04-17
	<p>SAR-Z Axis at Hotspot x:-1.87 y:12.91</p> 
SAR 1g(W/kg)	0.126
SAR 10g(W/kg)	0.074

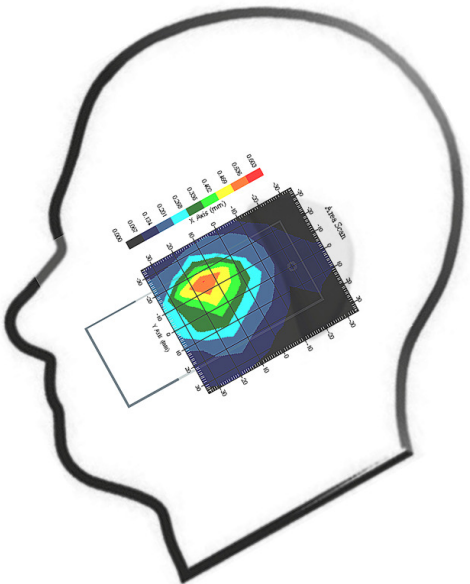
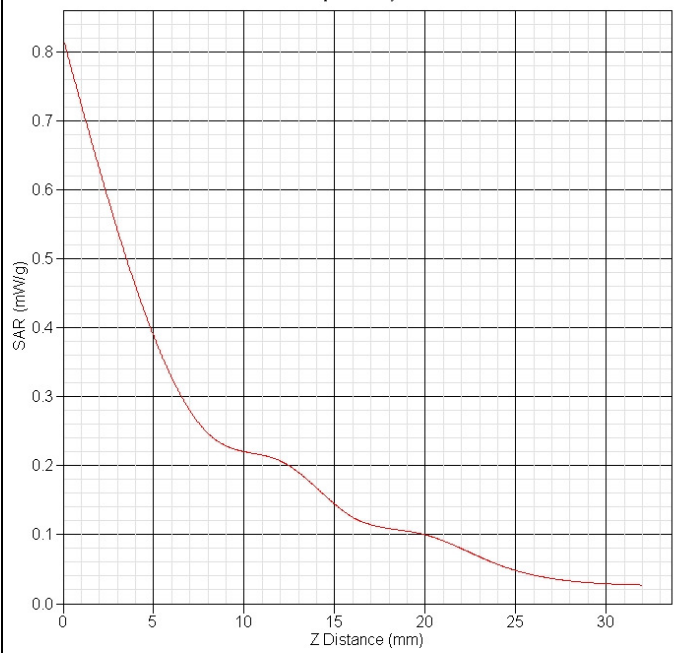
<b>GSM1900 Right cheek CH512</b>																	
Frequency(MHz)	1850.2																
Relative permittivity(real part)	41.55																
Conductivity(S/m)	1.42																
Variation(%)	-0.484																
Duty Cycle Factor	8																
Crest factor	8																
Conversion Factor	5.7																
Probe Sensitivity	1.20 1.20 1.20 $\mu V/(V/m)^2$																
Data	2013-04-17																
	<p>SAR-Z Axis at Hotspot x:30.09 y:-6.94</p>  <table border="1"> <caption>SAR-Z Axis Data</caption> <thead> <tr> <th>Z Distance (mm)</th> <th>SAR (mW/g)</th> </tr> </thead> <tbody> <tr><td>0</td><td>0.80</td></tr> <tr><td>5</td><td>0.40</td></tr> <tr><td>10</td><td>0.22</td></tr> <tr><td>15</td><td>0.12</td></tr> <tr><td>20</td><td>0.10</td></tr> <tr><td>25</td><td>0.06</td></tr> <tr><td>30</td><td>0.05</td></tr> </tbody> </table>	Z Distance (mm)	SAR (mW/g)	0	0.80	5	0.40	10	0.22	15	0.12	20	0.10	25	0.06	30	0.05
Z Distance (mm)	SAR (mW/g)																
0	0.80																
5	0.40																
10	0.22																
15	0.12																
20	0.10																
25	0.06																
30	0.05																
SAR 1g(W/kg)	0.399																
SAR 10g(W/kg)	0.224																

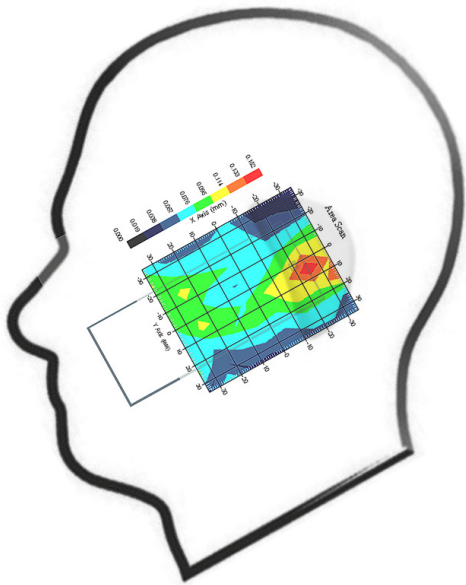
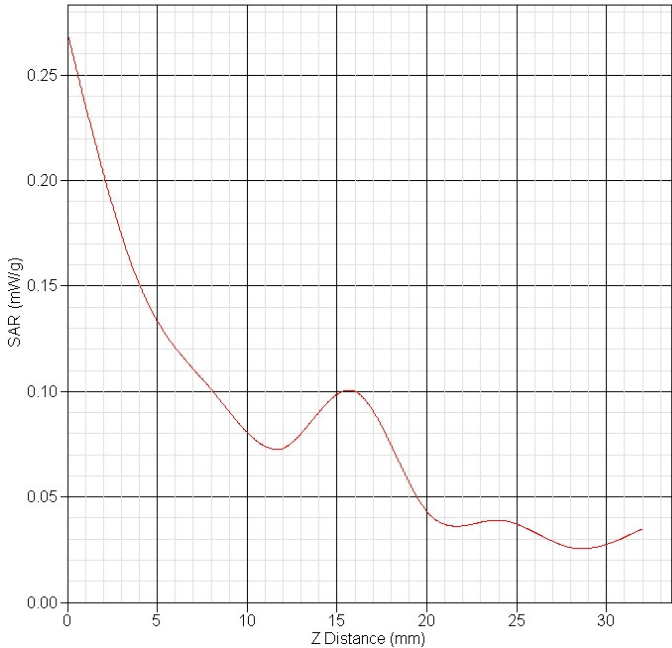
<b>GSM1900 Right tilt CH512</b>	
Frequency(MHz)	1850.2
Relative permittivity(real part)	41.55
Conductivity(S/m)	1.42
Variation(%)	-3.892
Duty Cycle Factor	8
Crest factor	8
Conversion Factor	5.7
Probe Sensitivity	1.20 1.20 1.20 $\mu V/(V/m)^2$
Data	2013-04-17
	<p>SAR-Z Axis at Hotspot x:-9.93 y:13.03</p> 
SAR 1g(W/kg)	0.140
SAR 10g(W/kg)	0.081

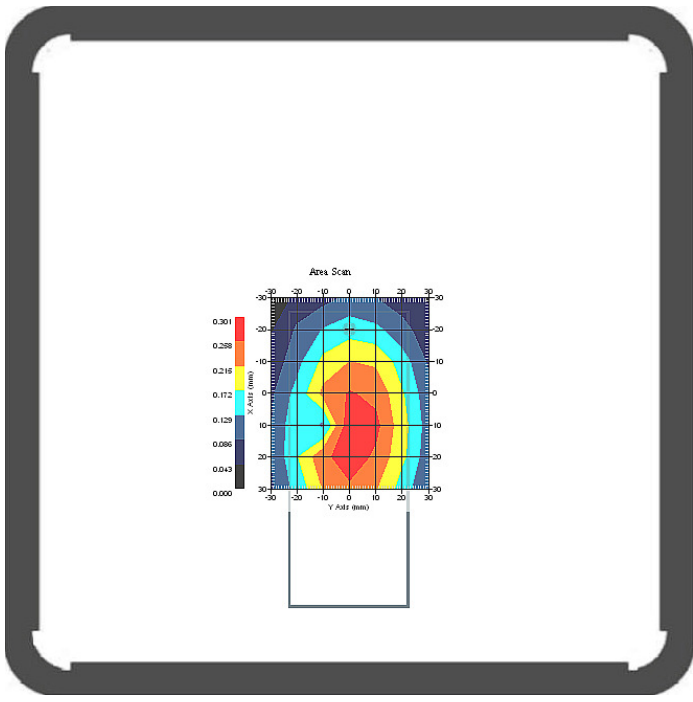
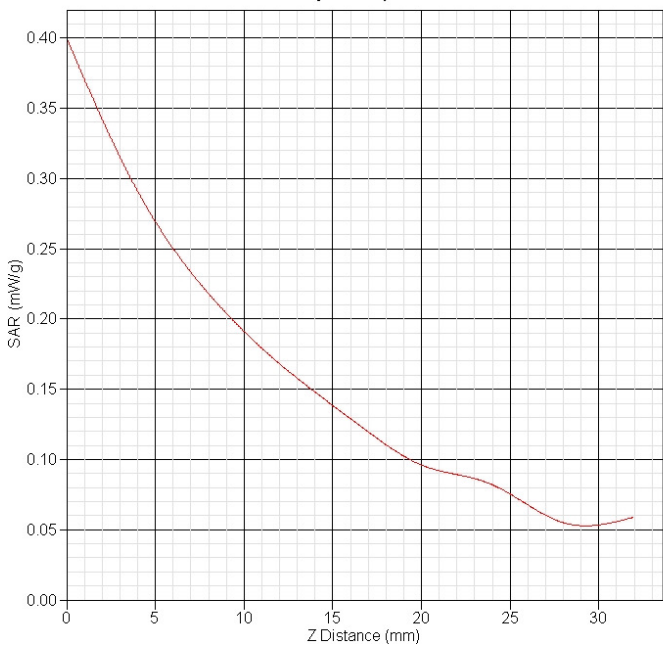
<b>GPRS850 body Front CH190</b>	
Frequency(MHz)	836.6
Relative permittivity(real part)	53.32
Conductivity(S/m)	0.96
Variation(%)	0.816
Duty Cycle Factor	4
Crest factor	4
Conversion Factor	6.4
Probe Sensitivity	1.20 1.20 1.20 $\mu V/(V/m)^2$
Data	2013-04-17
	<p>SAR-Z Axis at Hotspot x:18.02 y:-0.13</p> 
SAR 1g(W/kg)	0.272
SAR 10g(W/kg)	0.180

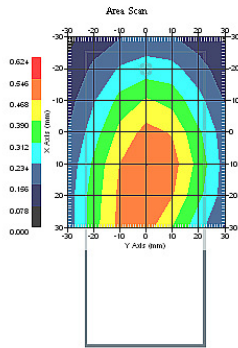
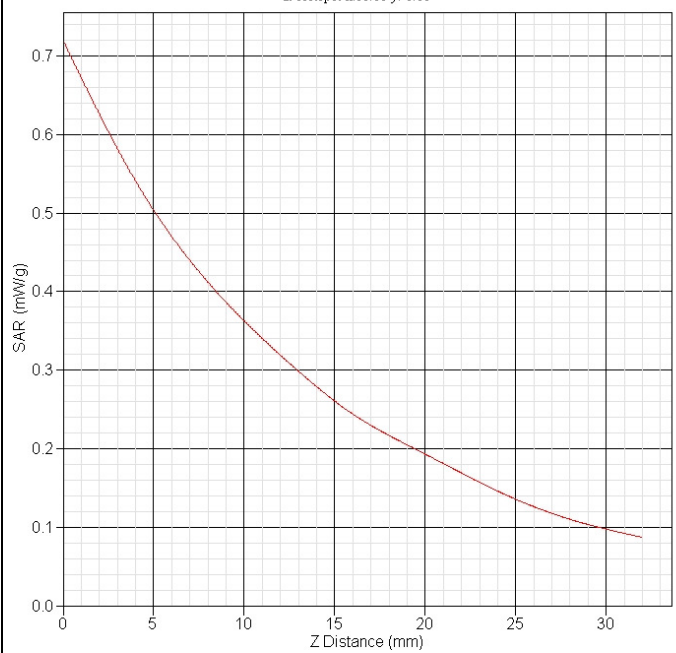
<b>GPRS850 body Back CH190</b>	
Frequency(MHz)	836.6
Relative permittivity(real part)	53.32
Conductivity(S/m)	0.96
Variation(%)	-0.570
Duty Cycle Factor	4
Crest factor	4
Conversion Factor	6.4
Probe Sensitivity	1.20 1.20 1.20 $\mu V/(V/m)^2$
Data	2013-04-17
	<p>SAR-Z Axis at Hotspot x:10.06 y:-0.16</p> 
SAR 1g(W/kg)	0.402
SAR 10g(W/kg)	0.281

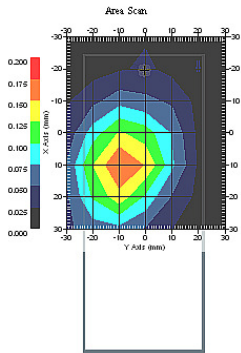
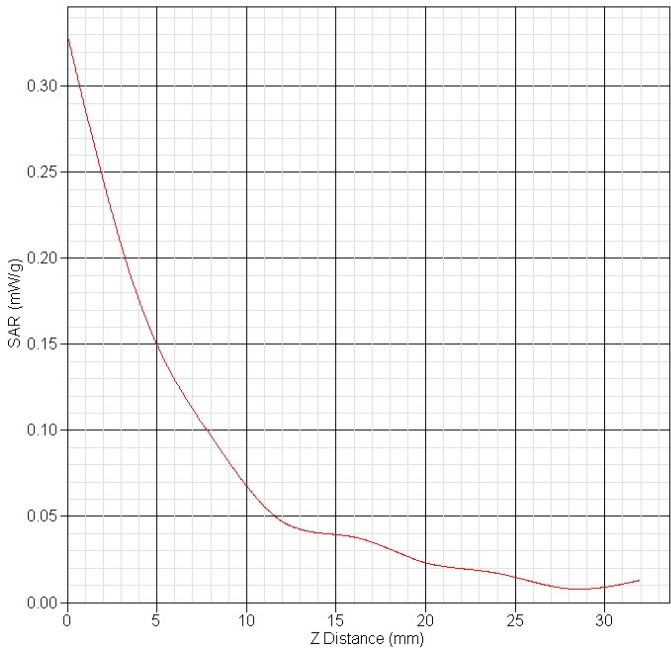
<b>GPRS1900 body Front CH512</b>																	
Frequency(MHz)	1850.2																
Relative permittivity(real part)	52.93																
Conductivity(S/m)	1.51																
Variation(%)	-1.722																
Duty Cycle Factor	4																
Crest factor	4																
Conversion Factor	5.4																
Probe Sensitivity	1.20 1.20 1.20 $\mu V/(V/m)^2$																
Data	2013-04-17																
	<p>SAR-Z Axis at Hotspot x:10.00 y:-10.11</p>  <table border="1"> <caption>SAR-Z Axis Data Points (Estimated)</caption> <thead> <tr> <th>Z Distance (mm)</th> <th>SAR (mW/kg)</th> </tr> </thead> <tbody> <tr><td>0</td><td>0.32</td></tr> <tr><td>5</td><td>0.15</td></tr> <tr><td>10</td><td>0.06</td></tr> <tr><td>15</td><td>0.04</td></tr> <tr><td>20</td><td>0.02</td></tr> <tr><td>25</td><td>0.01</td></tr> <tr><td>30</td><td>0.01</td></tr> </tbody> </table>	Z Distance (mm)	SAR (mW/kg)	0	0.32	5	0.15	10	0.06	15	0.04	20	0.02	25	0.01	30	0.01
Z Distance (mm)	SAR (mW/kg)																
0	0.32																
5	0.15																
10	0.06																
15	0.04																
20	0.02																
25	0.01																
30	0.01																
SAR 1g(W/kg)	0.166																
SAR 10g(W/kg)	0.082																

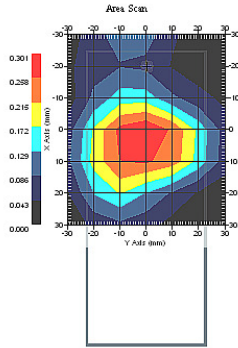
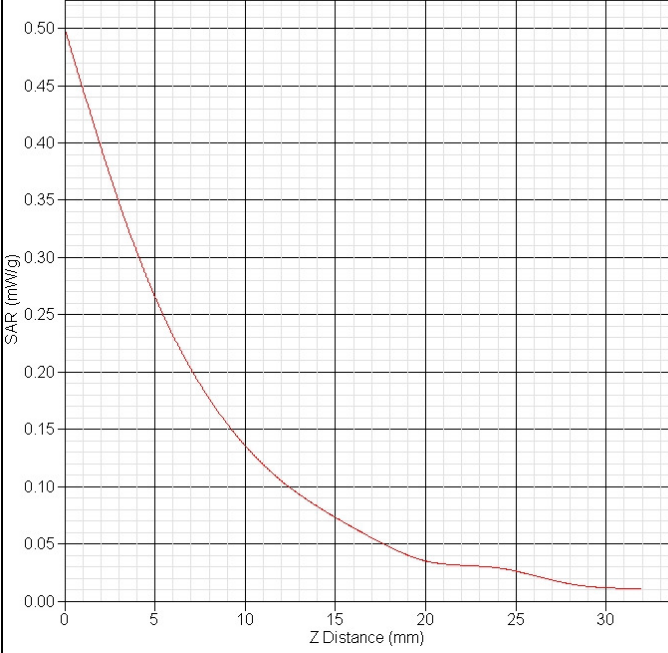
<b>GPRS1900 body Back CH512</b>	
Frequency(MHz)	1850.2
Relative permittivity(real part)	52.93
Conductivity(S/m)	1.51
Variation(%)	0.809
Duty Cycle Factor	4
Crest factor	4
Conversion Factor	5.4
Probe Sensitivity	1.20 1.20 1.20 $\mu V/(V/m)^2$
Data	2013-04-17
	<p>SAR-Z Axis at Hotspot x:0.08 y:-0.16</p> 
SAR 1g(W/kg)	0.269
SAR 10g(W/kg)	0.132



SAR Test Photographs

Left Head (EUT Cheek)

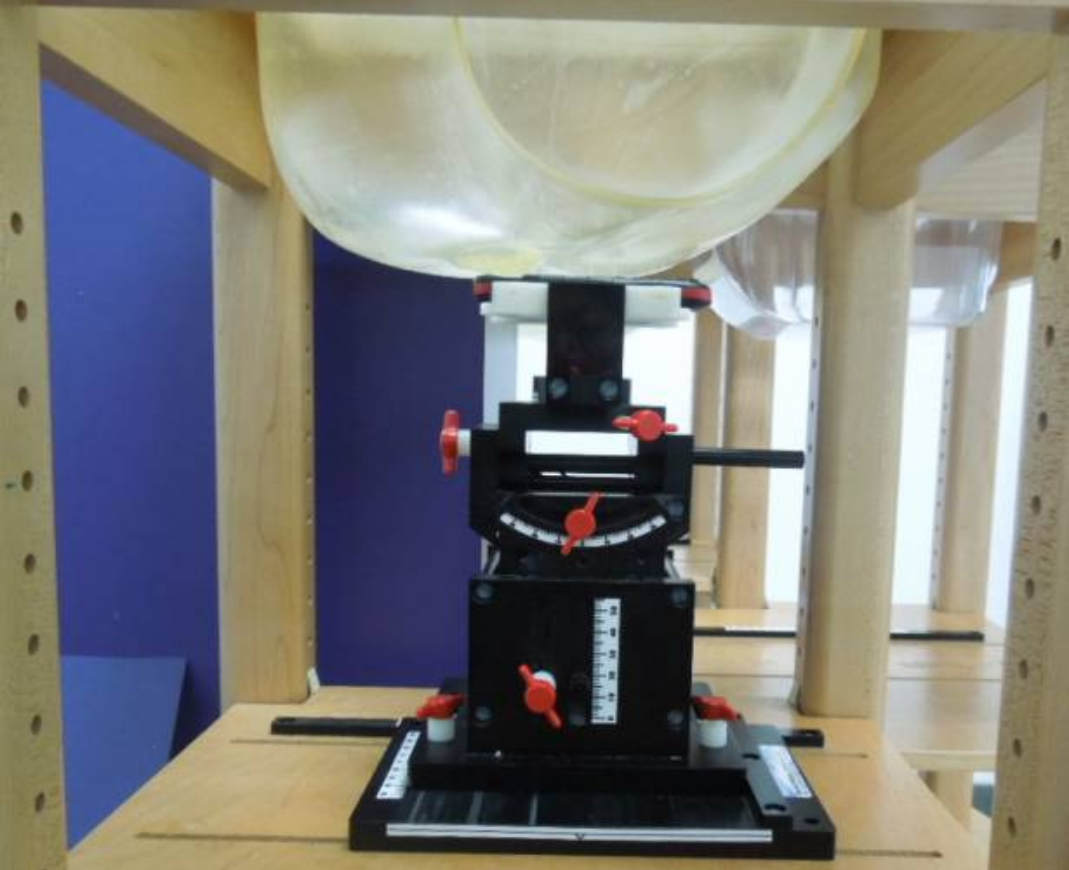

Left Head (EUT Tilt)

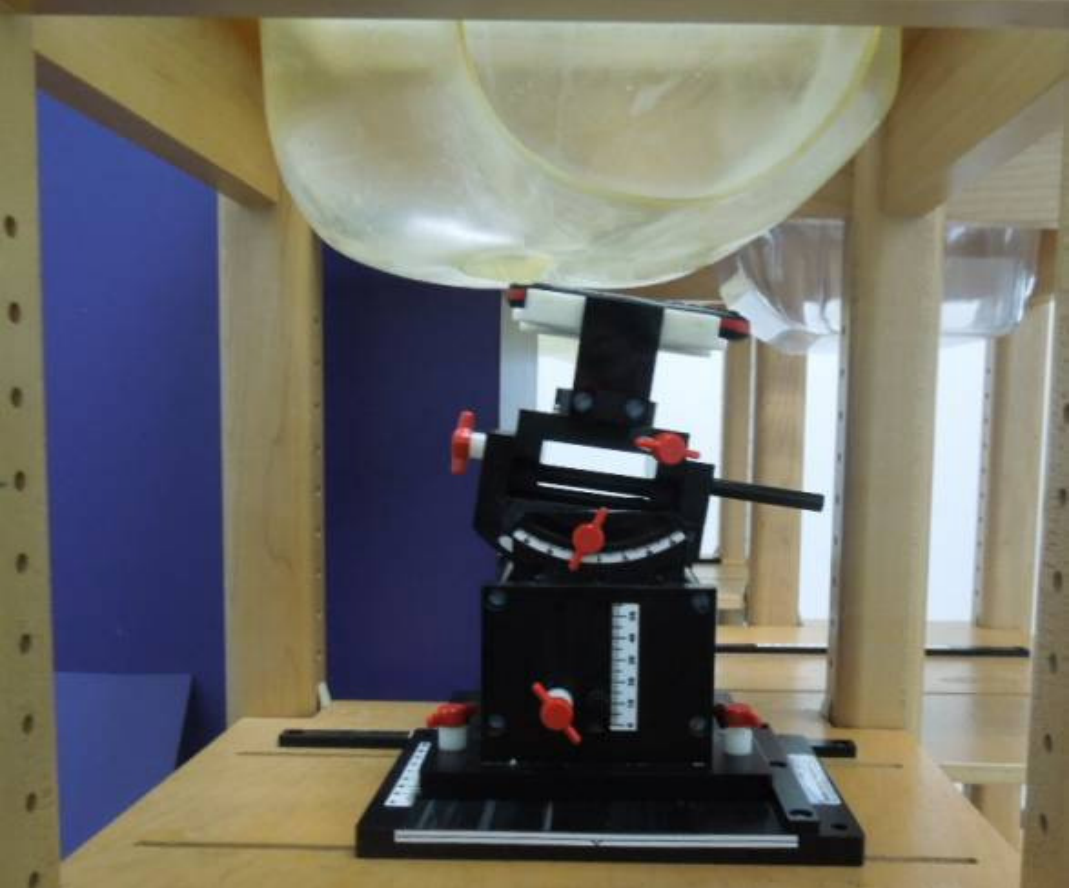

**Right Head (EUT Cheek)**

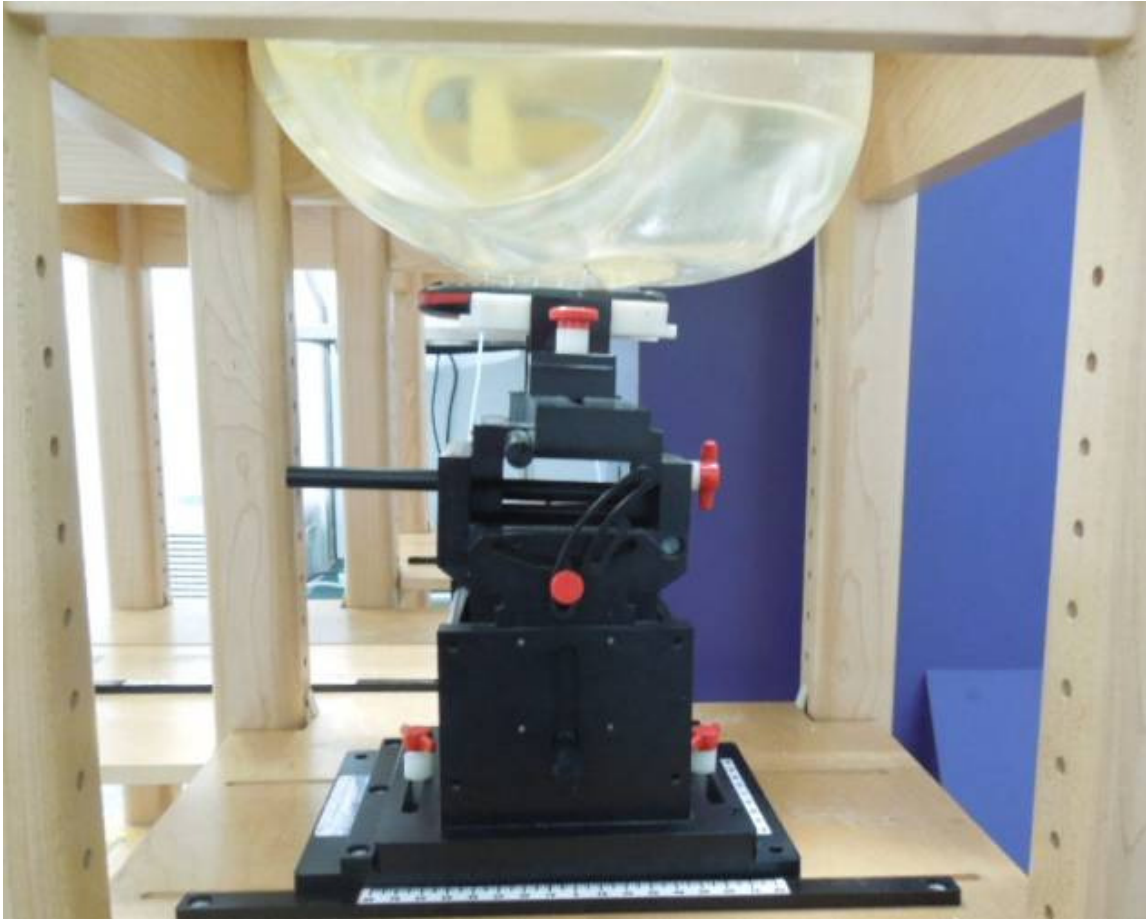

**Right Head (EUT Tilt)**



**Body Back (1.5cm)**



**Body Front (1.5cm)**





**Validation**

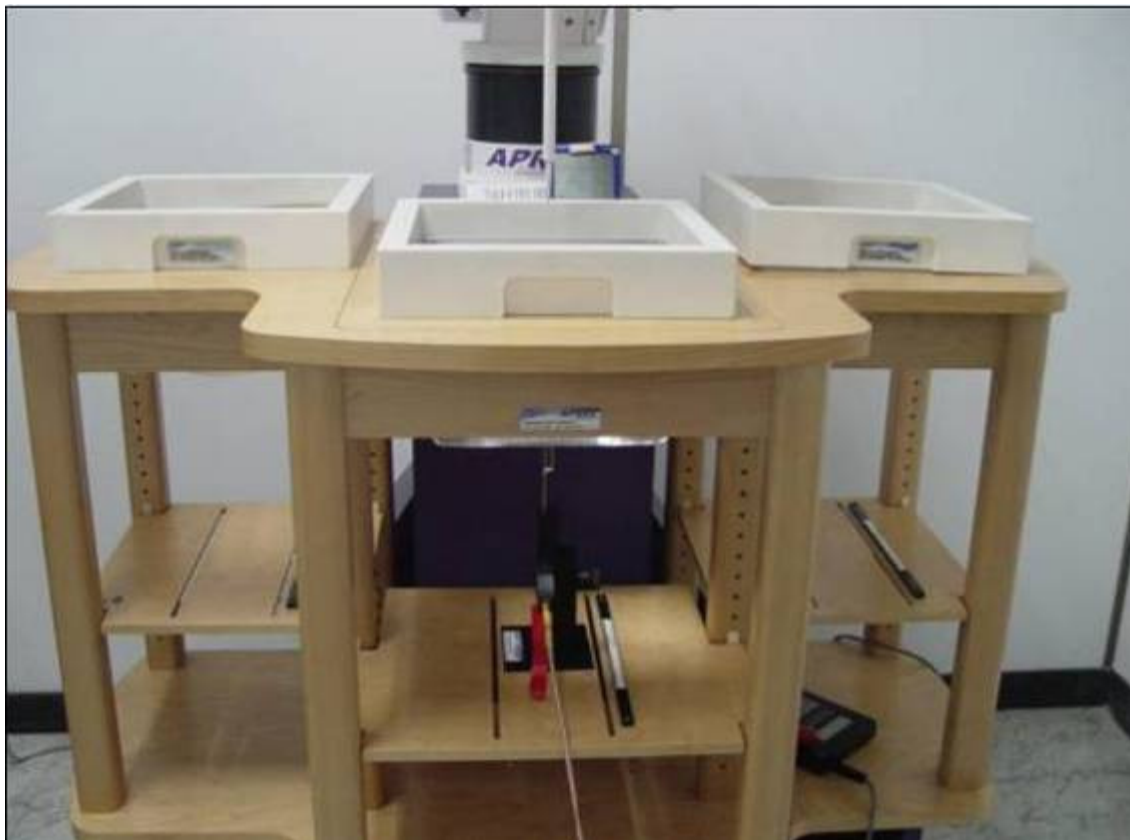

**Photo of Liquid Height for Head SAR**

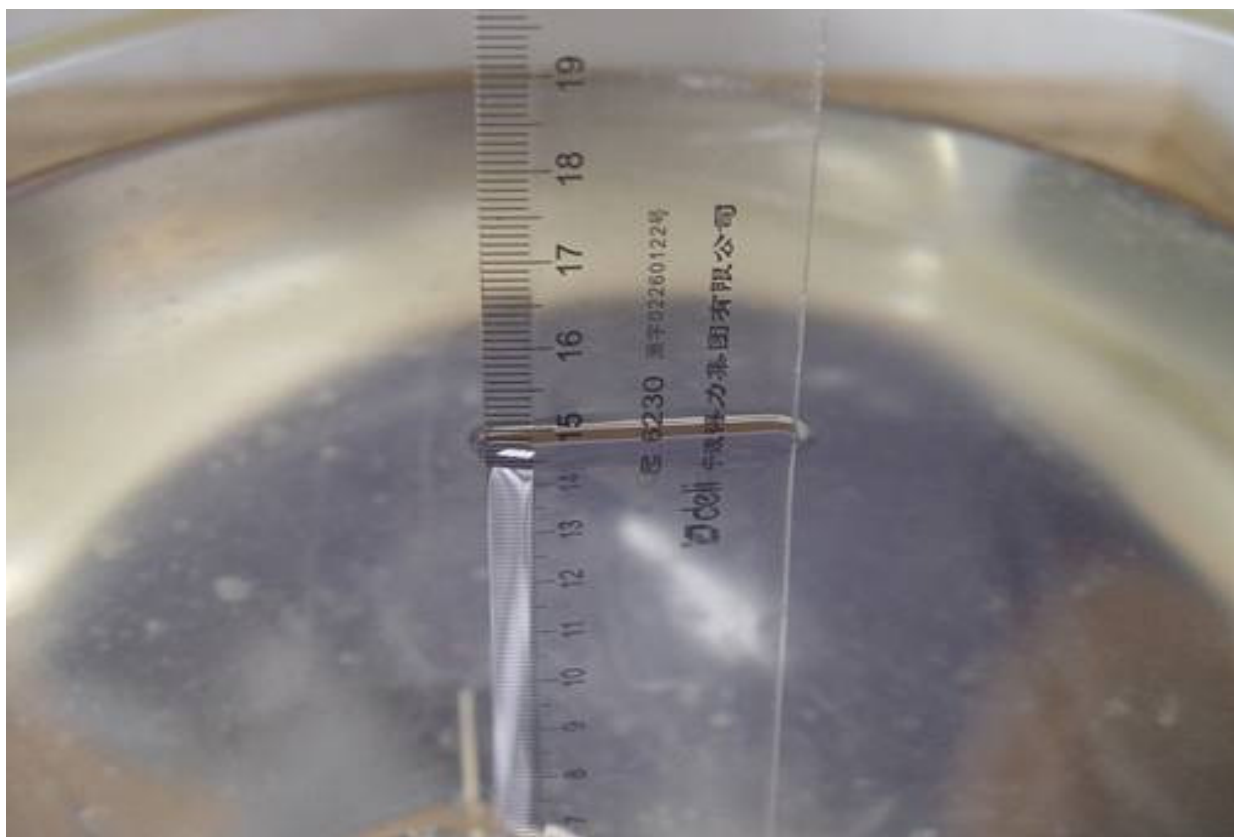

**Photo of Liquid Height for Body SAR**



**EUT**





**NCL CALIBRATION LABORATORIES**

Calibration File No.: PC 1432

Client.: IAC

**CERTIFICATE OF CALIBRATION**

It is certified that the equipment identified below has been calibrated in the  
**NCL CALIBRATION LABORATORIES** by qualified personnel following recognized  
procedures and using transfer standards traceable to NRC/NIST.

Equipment: Miniature Isotropic RF Probe

Record of Calibration

Head and Body

Manufacturer: APREL Laboratories

**Model No.:** E-020**Serial No.:** 500-00273

**Calibration Procedure:** D01-032-E020-V2, D22-012-Tissue, D28-002-Dipole  
**Project No:** ISL-E020-5895

**Calibrated:** 1<sup>st</sup> October 2012**Released on:** 5<sup>th</sup> October 2012

This Calibration Certificate is Incomplete Unless Accompanied with the Calibration Results Summary

Released By: \_\_\_\_\_



Art Brennan, Quality Manager

**NCL CALIBRATION LABORATORIES**

303 Terry Fox Drive, Suite 102  
Kanata, Ontario  
CANADA K2K 3J1

Division of APREL  
TEL: (613) 435-8300  
FAX: (613) 435-8306

**NCL Calibration Laboratories**Division of APREL Inc.

---

**Introduction**

This Calibration Report reproduces the results of the calibration performed in line with the references listed below. Calibration is performed using accepted methodologies as per the references listed below. Probes are calibrated for air, and tissue and the values reported are the results from the physical quantification of the probe through meteorological practices.

**Calibration Method**

Probes are calibrated using the following methods.

<1000MHz

TEM Cell for sensitivity in air

Standard phantom using temperature transfer method for sensitivity in tissue

>1000MHz

Waveguide\* method to determine sensitivity in air and tissue

\*Waveguide is numerically (simulation) assessed to determine the field distribution and power

The boundary effect for the probe is assessed using a standard flat phantom where the probe output is compared against a numerically simulated series of data points

**References**

- o IEEE Standard 1528 (2003) including Amendment 1  
IEEE Recommended Practice for Determining the Peak Spatial-Average Specific Absorption Rate (SAR) in the Human Head from Wireless Communications Devices: Measurement Techniques
- o EN 62209-1 (2006)  
Human Exposure to RF Fields from hand-held and body-mounted wireless communication devices - Human models, instrumentation, and procedures-Part 1: Procedure to measure the Specific Absorption Rate (SAR) for hand-held mobile wireless devices
- o IEC 62209-2 Ed. 1.0 (2010-03)  
Human exposure to RF fields from hand-held and body-mounted wireless devices - Human models, instrumentation, and procedures - Part 2: specific absorption rate (SAR) for wireless communication devices (30 MHz - 6 GHz)
- o TP-D01-032-E020-V2 E-Field probe calibration procedure
- o D22-012-Tissue dielectric tissue calibration procedure
- o D28-002-Dipole procedure for validation of SAR system using a dipole
- o IEEE 1309 Draft Standard for Calibration of Electromagnetic Field Sensors and Probes, Excluding Antennas, from 9kHz to 40GHz

---

Page 2 of 10

This page has been reviewed for content and attested to on Page 2 of this document.



**NCL Calibration Laboratories**

Division of APREL Inc.

**Conditions**

Probe 500-00273 was a recalibration.

\*\*The probe was received in good working order, although at 1900MHz the uncertainty was higher than our standard (see note\*\*)

**Ambient Temperature of the Laboratory:** 22 °C +/- 1.5°C  
**Temperature of the Tissue:** 21 °C +/- 1.5°C  
**Relative Humidity:** < 60%

**Primary Measurement Standards**

Instrument	Serial Number	Cal due date
Power meter Anritsu MA2408A	90025437	Nov.5, 2012
Power Sensor Anritsu MA2481D	103555	Nov 5 2012
Attenuator HP 8495A (70dB)	1944A10711	Sept. 13, 2013
Network Analyzer Anritsu MT8801C	MB11855	Feb. 7, 2013

**Secondary Measurement Standards**

Signal Generator Agilent E4438C -506	MY55182336	June 6, 2013
--------------------------------------	------------	--------------

**Attestation**

The below named signatories have conducted the calibration and review of the data which is presented in this calibration report.

We the undersigned attest that to the best of our knowledge the calibration of this subject has been accurately conducted and that all information contained within the results pages have been reviewed for accuracy.



Art Brennan, Quality Manager



Dan Brooks, Test Engineer

---

Page 3 of 10

This page has been reviewed for content and attested to on Page 2 of this document.

**NCL Calibration Laboratories**Division of APREL Inc.

---

**Probe Summary**

<b>Probe Type:</b>	E-Field Probe E020
<b>Serial Number:</b>	500-00273
<b>Frequency:</b>	As presented on page 5
<b>Sensor Offset:</b>	1.56
<b>Sensor Length:</b>	2.5
<b>Tip Enclosure:</b>	Composite*
<b>Tip Diameter:</b>	< 2.9 mm
<b>Tip Length:</b>	55 mm
<b>Total Length:</b>	289 mm

\*Resistive to recommended tissue recipes per IEEE-1528

**Sensitivity in Air**

<b>Channel X:</b>	1.2 $\mu\text{V}/(\text{V}/\text{m})^2$
<b>Channel Y:</b>	1.2 $\mu\text{V}/(\text{V}/\text{m})^2$
<b>Channel Z:</b>	1.2 $\mu\text{V}/(\text{V}/\text{m})^2$
<b>Diode Compression Point:</b>	95 mV

---

Page 4 of 10

This page has been reviewed for content and attested to on Page 2 of this document.

---

**NCL Calibration Laboratories**

 Division of APREL Inc.
 

---

**Calibration for Tissue (Head H, Body B)**

Frequency	Tissue Type	Measured Epsilon	Measured Sigma	Calibration Uncertainty	Tolerance Uncertainty for 5%*	Conversion Factor
450 H	Head	X	X	X	X	X
450 B	Body	X	X	X	X	X
750 H	Head	X	X	X	X	X
750 B	Body	X	X	X	X	X
850 H	Head	42.86	0.95	3.5	3.4	6.5
850 B	Body	53.71	1.04	3.5	3.4	6.4
900 H	Head	41.5	0.99	3.5	3.4	6.1
900 B	Body	53.25	1.04	3.5	3.4	6.3
1450 H	Head	X	X	X	X	X
1450 B	Body	X	X	X	X	X
1500 H	Head	X	X	X	X	X
1500 B	Body	X	X	X	X	X
1640 H	Head	X	X	X	X	X
1640 B	Body	X	X	X	X	X
1750 H	Head	X	X	X	X	X
1750 B	Body	X	X	X	X	X
1800 H	Head	36.85	1.35	3.5	2.7	5.5
1800 B	Body	52.38	1.5	3.5	2.7	5.4
1900 H	Head	38.21	1.46	3.5	2.7	5.7
1900 B	Body	52.1	1.59	3.5	2.7	5.4
2000 H	Head	X	X	X	X	X
2000 B	Body	X	X	X	X	X
2100 H	Head	39.8	1.49	3.5	2.9	5.0
2100 B	Body	53.0	1.58	3.5	2.9	4.9
2300 H	Head	X	X	X	X	X
2300 B	Body	X	X	X	X	X
2450 H	Head	38.2	1.84	3.5	3.5	4.65
2450 B	Body	50.63	1.99	3.5	3.5	4.4
2800 H	Head	X	X	X	X	X
2800 B	Body	X	X	X	X	X
3000 H	Head	X	X	X	X	X
3000 B	Body	X	X	X	X	X
3600 H	Head	X	X	X	X	X
3600 B	Body	X	X	X	X	X
5200 H	Head	X	X	X	X	X
5200 B	Body	X	X	X	X	X
5600 H	Head	X	X	X	X	X
5600 B	Body	X	X	X	X	X
5800 H	Head	X	X	X	X	X
5800 B	Body	X	X	X	X	X

---

 Page 5 of 10

This page has been reviewed for content and attested to on Page 2 of this document.

**NCL Calibration Laboratories**Division of APREL Inc.

---

**Boundary Effect:**

Uncertainty resulting from the boundary effect is less than 2.1% for the distance between the tip of the probe and the tissue boundary, when less than 0.58mm.

**Spatial Resolution:**

The spatial resolution uncertainty is less than 1.5% for 4.0mm diameter probe.  
The spatial resolution uncertainty is less than 1.0% for 2.5mm diameter probe.

**DAQ-PAQ Contribution**

To minimize the uncertainty calculation all tissue sensitivity values were calculated using a load impedance of 5 M $\Omega$ .

**Boundary Effect:**

For a distance of 0.58mm the worst case evaluated uncertainty (increase in the probe sensitivity) is less than 2.1%.

**NOTES:**

\*The maximum deviation from the centre frequency when comparing the lower to upper range is listed.

\*\*1800MHz Head was evaluated at close to the 10% allowable deviation; the deviation has now been normalized to within 2%.

\*\*\*1800MHz Body was evaluated at close to the 10% allowable deviation; the deviation has now been normalized to within 2%.

\*\*\*\*1900MHz Body was evaluated at close to the 10% allowable deviation; the deviation has now been normalized to within 2%.

\*\*\*\*\*2450MHz Head was evaluated at close to the 10% allowable deviation; the deviation has now been normalized to within 2%.

\*\*\*\*\*2450MHz Body was evaluated at close to the 10% allowable deviation; the deviation has now been normalized to within 2%.

---

Page 6 of 10

This page has been reviewed for content and attested to on Page 2 of this document.

NCL Calibration Laboratories  
Division of APREL Inc.

### Receiving Pattern Air

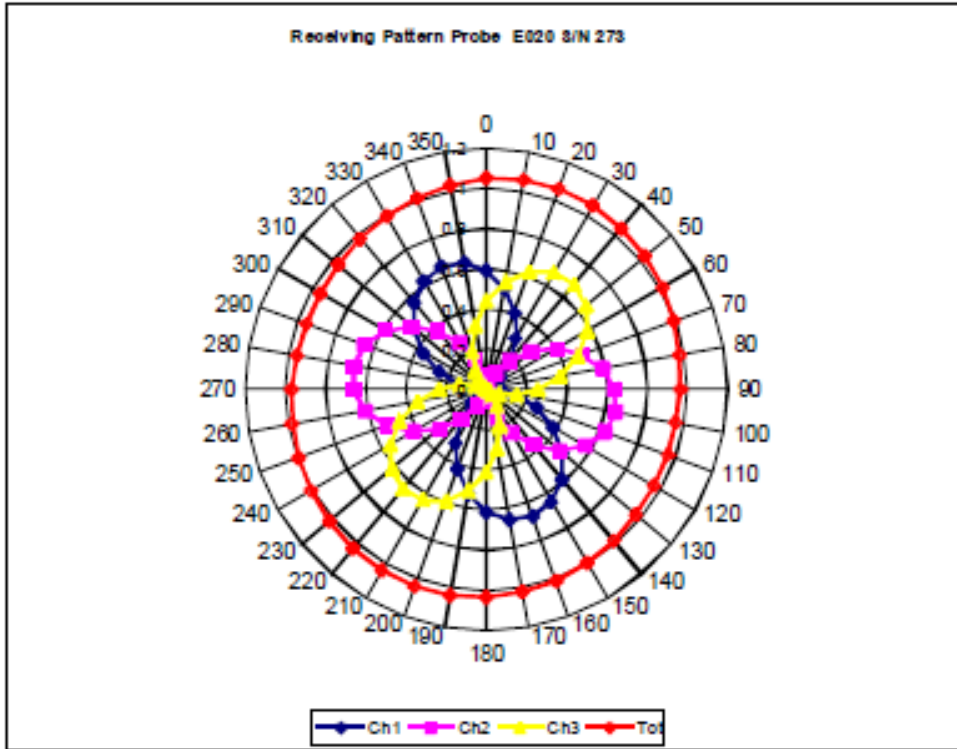

NCL Calibration Laboratories  
Division of APREL Inc.

### Isotropy Error Air

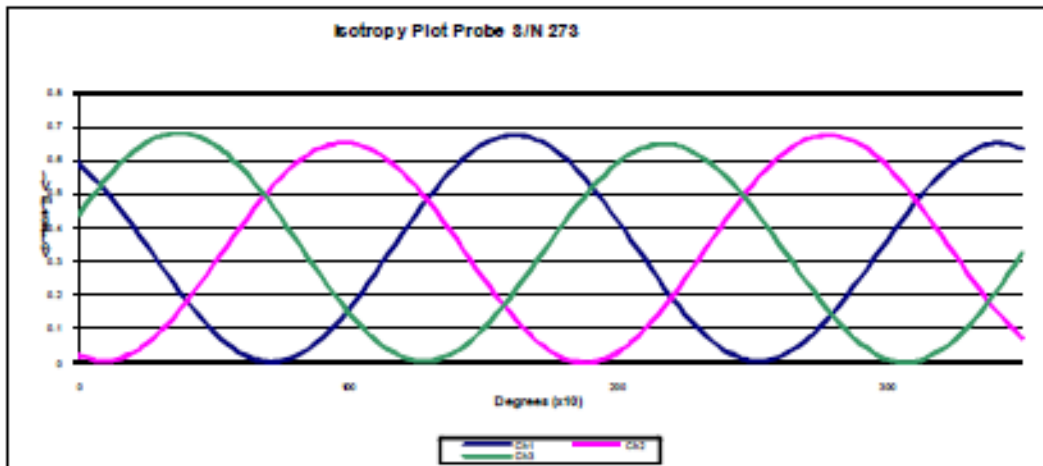
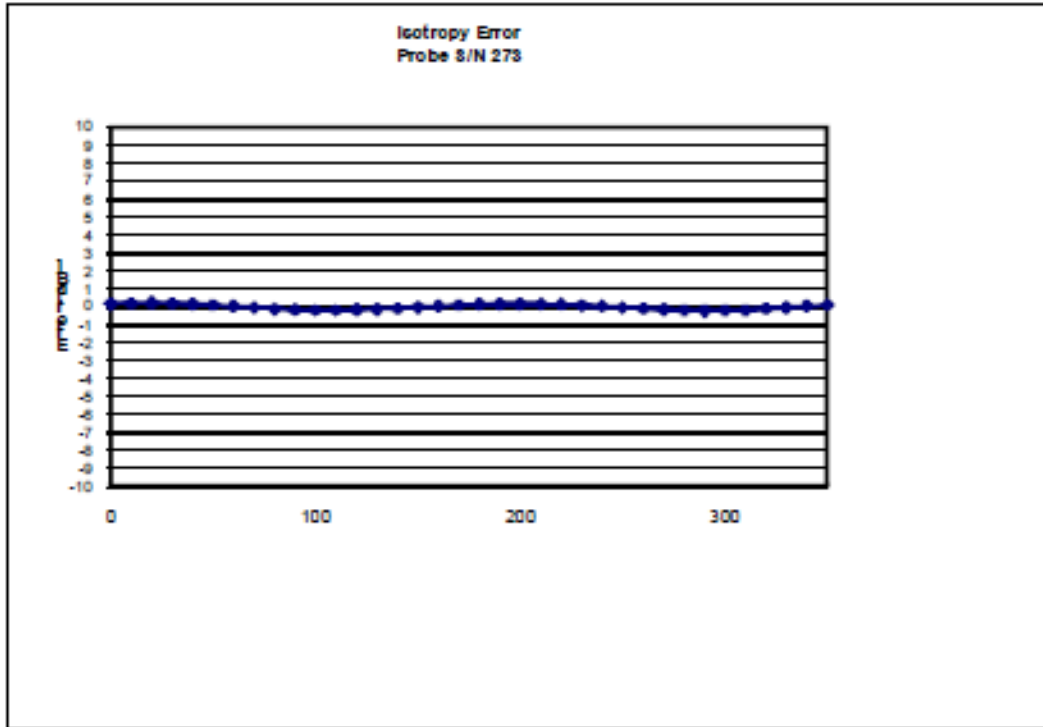

Isotropicity Tissue: 0.10 dB

NCL Calibration Laboratories  
Division of APREL Inc.

### Dynamic Range

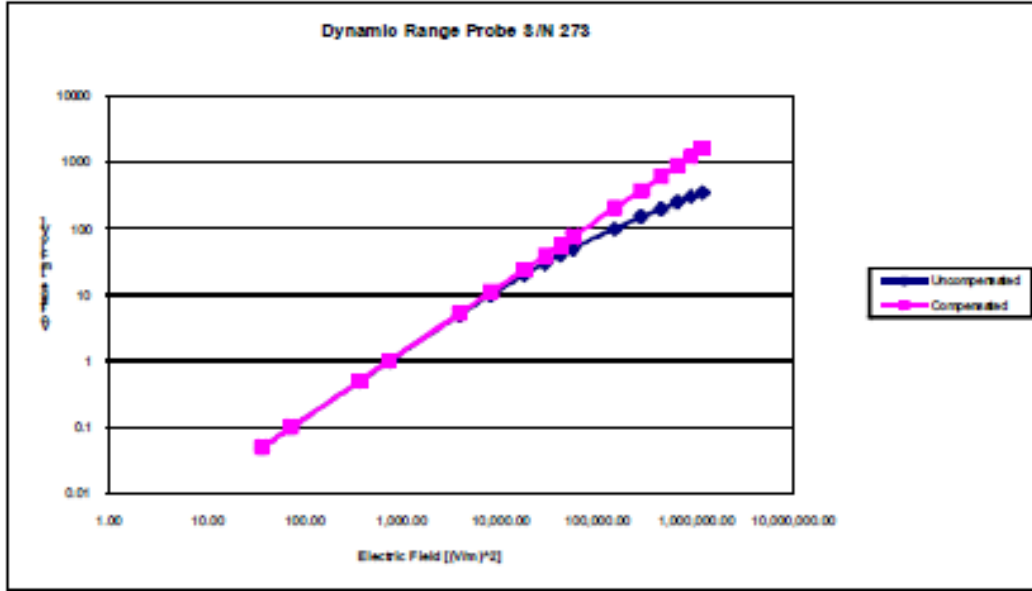

**NCL Calibration Laboratories**

Division of APREL Inc.

**Video Bandwidth**

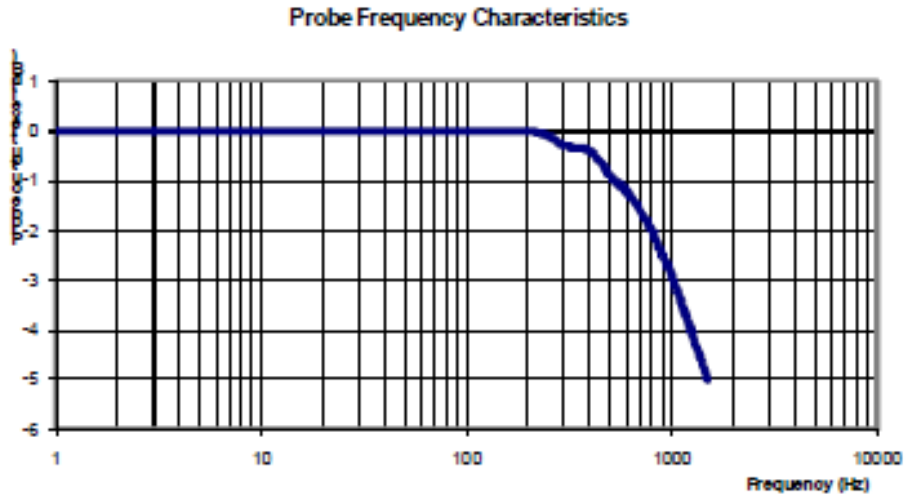

Video Bandwidth at 500 Hz                    1 dB  
Video Bandwidth at 1.02 KHz:            3 dB

**Test Equipment**

The test equipment used during Probe Calibration, manufacturer, model number and, current calibration status are listed and located on the main APREL server R:\NCL\Calibration Equipment\Instrument List May 2012.



**NCL CALIBRATION LABORATORIES**

Calibration File No: DC-1217/18  
Project Number: SGL-IAC-DC-5582-93

**CERTIFICATE OF CALIBRATION**

It is certified that the equipment identified below has been calibrated in the  
**NCL CALIBRATION LABORATORIES** by qualified personnel following recognized  
procedures and using transfer standards traceable to NRC/NIST.

Validation Dipole  
835MHz Head & Body

Manufacturer: APREL Laboratories  
Part number: ALS-D-835-S-2  
Frequency: 835MHz  
Serial No: 180-00558

Customer: IAC

Calibrated: 17<sup>th</sup> May 2011  
Released on: 27<sup>th</sup> May 2011

This Calibration Certificate is Incomplete Unless Accompanied with the Calibration Results Summary

Released By: \_\_\_\_\_

**NCL** CALIBRATION LABORATORIES

303 Terry Fox Drive, Suite 102  
Kanata, Ontario  
CANADA K2K 3J1

Division of APREL  
TEL: (613) 435-8300  
FAX: (613) 435-8306

**NCL Calibration Laboratories**

Division of APREL Inc.

**Conditions**

Dipole 180-00556 was a re-calibration.

**Ambient Temperature of the Laboratory:** 22 °C +/- 0.5°C

**Temperature of the Tissue:** 21 °C +/- 0.5°C

Dipoles are calibrated on the ALSAS-10U with a feed power normalized to 1Watt.

We the undersigned attest that to the best of our knowledge the calibration of this device has been accurately conducted and that all information contained within this report has been reviewed for accuracy.



-----  
Stuart Nicol



-----  
C. Teodorian

**Primary Measurement Standards**

Instrument	Serial Number	Cal due date
Power meter Anritsu MA2408A	90025437	Nov.4, 2010
Power Sensor Anritsu MA2481D	103555	Nov 4, 2010
Attenuator HP 8495A (70dB)	1944A10711	Sept. 14, 2010
Network Analyzer Anritsu MT8801C	MB11855	Feb. 8, 2011

**Secondary Measurement Standards**

Signal Generator Agilent E4438C -506	MY55182336	June 7, 2011
--------------------------------------	------------	--------------

This page has been reviewed for content and attested to by signature within this document.

**NCL Calibration Laboratories**  
 Division of APREL Inc.

### Calibration Results Summary

The following results relate the Calibrated Dipole and should be used as a quick reference for the user.

#### Mechanical Dimensions

Length: 161.0 mm  
 Height: 89.8 mm

#### Electrical Specification 835MHz

Tissue Type	Return Loss:	Impedance:	SWR:
Head	-26.655	51.666	1.102U
Body	-22.106	57.482	1.177U

#### System Validation Results

Tissue	Frequency	1 Gram	10 Gram	Peak
Head	835 MHz	9.590	6.003	15.013
Body	835 MHz	9.981	6.006	15.013

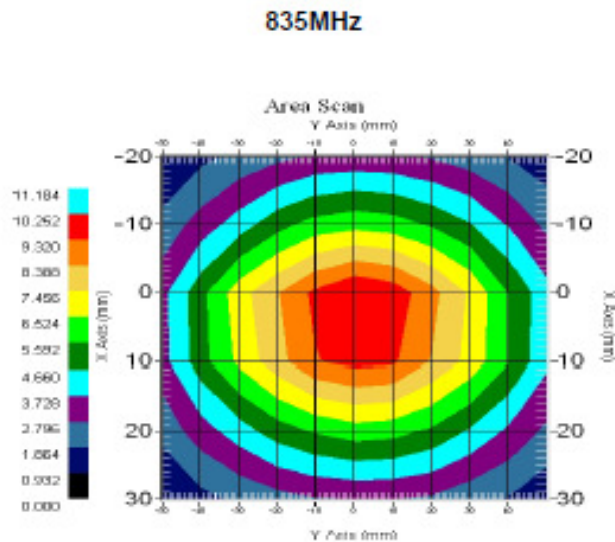

This page has been reviewed for content and attested to by signature within this document.

**NCL Calibration Laboratories**

Division of APREL Inc.

**Introduction**

This Calibration Report has been produced in line with the SSI Dipole Calibration Procedure SSI-TP-018-ALSAS. The results contained within this report are for Validation Dipole 190-00606. The calibration routine consisted of a three-step process. Step 1 was a mechanical verification of the dipole to ensure that it meets the mechanical specifications. Step 2 was an Electrical Calibration for the Validation Dipole, where the SWR, Impedance, and the Return loss were assessed. Step 3 involved a System Validation using the ALSAS-10U, along with APREL E-030 130 MHz to 26 GHz E-Field Probe Serial Number 215.

**References**

- IEEE Standard 1528 (2003) including Amendment 1  
IEEE Recommended Practice for Determining the Peak Spatial-Average Specific Absorption Rate (SAR) in the Human Head from Wireless Communications Devices: Measurement Techniques
- EN 62209-1 (2006)  
Human Exposure to RF Fields from hand-held and body-mounted wireless communication devices - Human models, instrumentation, and procedures-Part 1: Procedure to measure the Specific Absorption Rate (SAR) for hand-held mobile wireless devices
- IEC 62209-2 Ed. 1.0 (2010-03)  
Human exposure to RF fields from hand-held and body-mounted wireless devices - Human models, instrumentation, and procedures - Part 2: specific absorption rate (SAR) for wireless communication devices (30 MHz - 6 GHz)
- TP-D01-032-E020-V2 E-Field probe calibration procedure
- D22-012-Tissue dielectric tissue calibration procedure
- D28-002-Dipole procedure for validation of SAR system using a dipole
- IEEE 1309 Draft Standard for Calibration of Electromagnetic Field Sensors and Probes, Excluding Antennas, from 9kHz to 40GHz

**Conditions**

Dipole 190-00606 was a re-calibration.

**Ambient Temperature of the Laboratory:** 22 °C +/- 0.5°C  
**Temperature of the Tissue:** 20 °C +/- 0.5°C

This page has been reviewed for content and attested to by signature within this document.

4

**NCL Calibration Laboratories**  
 Division of APREL Inc.

**Electrical Calibration**

**Electrical Specification 835MHz**

Tissue Type	Measured Epsilon	Measured Sigma
Head	41.09	0.89
Body	53.15	0.95

**Head Tissue**

S11 FORWARD REFLECTION

LOG MAGNITUDE      REF=-20.000 dB      5.000 dB/DIV

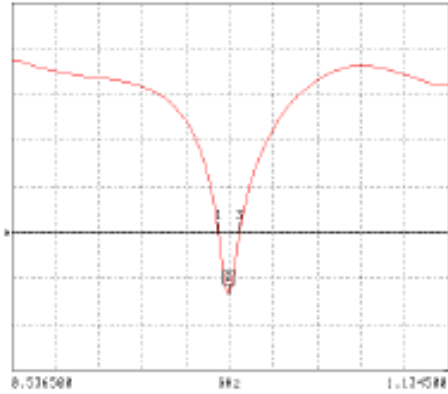

CH 1 - S11  
 5.8500 MHz REF  
 0.000 dB OFFSET  
 0.00° OFFSET

MARKER 2  
 8.835000 MHz  
 -20.000 dB

MARKER TO MAX  
 MARKER TO MIN

1 8.830834 MHz  
 -20.001 dB

3 8.849726 MHz  
 -20.001 dB

MARKER READOUT FUNCTIONS

**Body Tissue**

S11 FORWARD REFLECTION

LOG MAGNITUDE      REF=-20.000 dB      5.000 dB/DIV

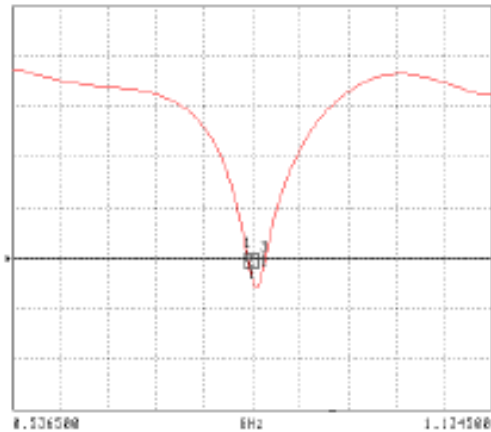

CH 1 - S11  
 5.8500 MHz REF  
 0.000 dB OFFSET  
 0.00° OFFSET

MARKER 2  
 8.835000 MHz  
 -22.106 dB

MARKER TO MAX  
 MARKER TO MIN

1 8.838132 MHz  
 -20.270 dB

3 8.850698 MHz  
 -20.742 dB

MARKER READOUT FUNCTIONS

This page has been reviewed for content and attested to by signature within this document.

**NCL Calibration Laboratories**  
 Division of APREL Inc.

**Electrical Specification 835MHz**  
**Impedance**

Tissue Type	Measured Epsilon	Measured Sigma
Head	41.09	0.89
Body	53.15	0.95

**Head Tissue**

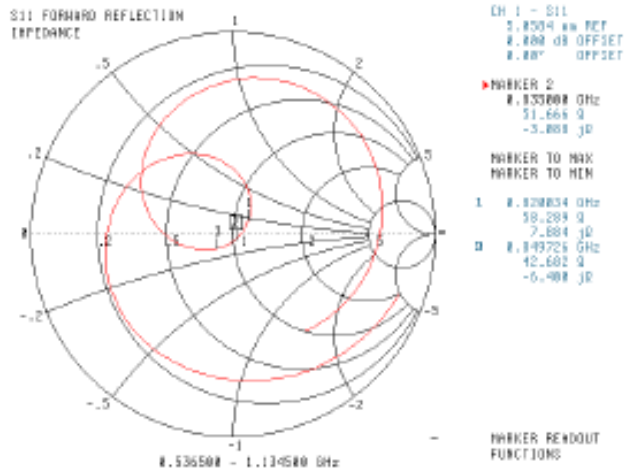

**Body Tissue**

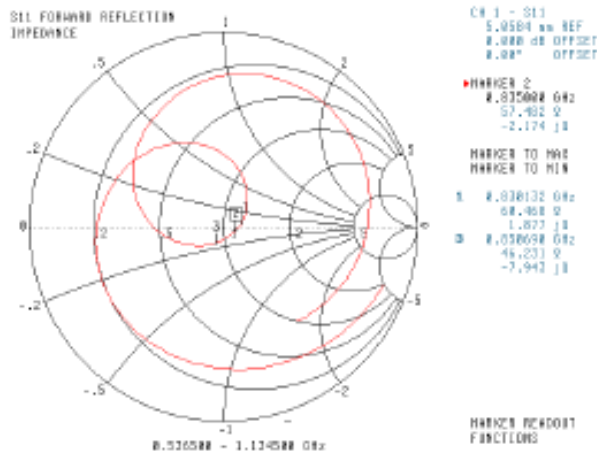

This page has been reviewed for content and attested to by signature within this document.



**NCL Calibration Laboratories**

Division of APREL Inc.

**Electrical Specification 835MHz  
Standing Wave Ratio**

Tissue Type	Measured Epsilon	Measured Sigma
Head	41.09	0.89
Body	53.15	0.95

**Head Tissue**

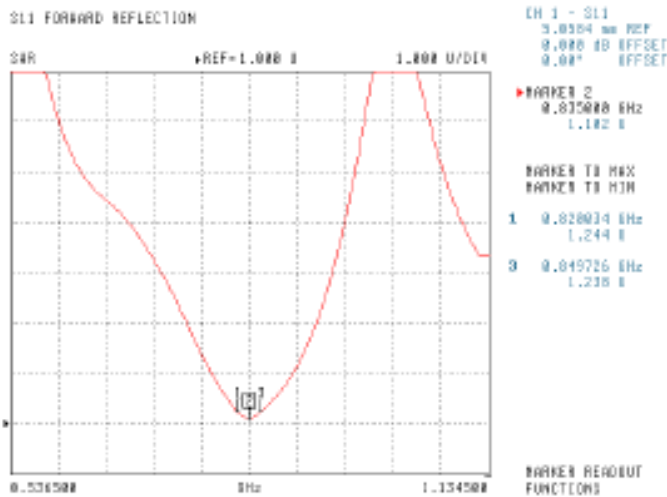

**Body Tissue**

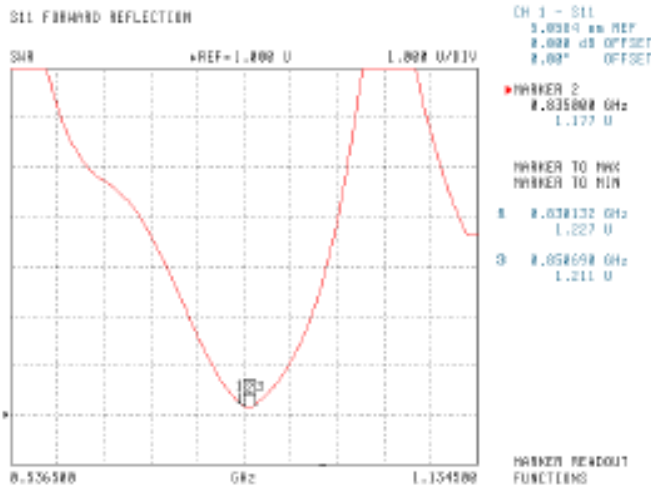

This page has been reviewed for content and attested to by signature within this document.

**NCL Calibration Laboratories**Division of APREL Inc.

---

**Test Equipment**

The test equipment used during Probe Calibration, manufacturer, model number and, current calibration status are listed and located on the main APREL server R:\NCL\Calibration Equipment\Instrument List May 2011.

This page has been reviewed for content and attested to by signature within this document.

8



**NCL CALIBRATION LABORATORIES**

Calibration File No: DC-1224/5  
Project Number: SGL-IAC-DC-5582-93

**CERTIFICATE OF CALIBRATION**

It is certified that the equipment identified below has been calibrated in the  
**NCL CALIBRATION LABORATORIES** by qualified personnel following recognized  
procedures and using transfer standards traceable to NRC/NIST.

Validation Dipole  
1900MHz Head & Body

Manufacturer: APREL Laboratories  
Part number: ALS-D-1900-S-2  
Frequency: 1900MHz  
Serial No: 210-00707

Customer: IAC

Calibrated: 16<sup>th</sup> May 2011  
Released on: 27<sup>th</sup> May 2011

This Calibration Certificate is incomplete unless accompanied with the Calibration Results Summary

Released By: \_\_\_\_\_

**NCL** CALIBRATION LABORATORIES

303 Terry Fox Drive, Suite 102  
Kanata, Ontario  
CANADA K2K 3J1

Division of APREL  
TEL: (613) 435-8300  
FAX: (613) 435-8306

**NCL Calibration Laboratories**  
Division of APREL Inc.

---

**Conditions**

Dipole 210-00707 was a new dipole taken from stock.

**Ambient Temperature of the Laboratory:** 22 °C +/- 0.5°C  
**Temperature of the Tissue:** 21 °C +/- 0.5°C

Dipoles are calibrated on the ALSAS-10U with a feed power normalized to 1Watt.

We the undersigned attest that to the best of our knowledge the calibration of this device has been accurately conducted and that all information contained within this report has been reviewed for accuracy.

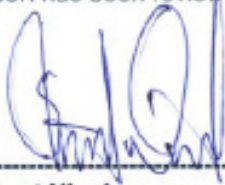

-----  
**Stuart Nicol**



-----  
**C. Teodorian**

**Primary Measurement Standards**

Instrument	Serial Number	Cal due date
Power meter Anritsu MA2408A	190025437	Nov.4, 2010
Power Sensor Anritsu MA2481D	103555	Nov 4, 2010
Attenuator HP 8495A (70dB)	1944A10711	Sept. 14, 2010
Network Analyzer Anritsu MT8801C	MB11855	Feb. 8, 2011

**Secondary Measurement Standards**

Signal Generator Agilent E4438C -506	MY55182336	June 7, 2011
--------------------------------------	------------	--------------

This page has been reviewed for content and attested to by signature within this document.

**NCL Calibration Laboratories**

Division of APREL Inc.

**Calibration Results Summary**

The following results relate the Calibrated Dipole and should be used as a quick reference for the user.

**Mechanical Dimensions**

Length: 67.1 mm  
 Height: 38.9 mm

**Electrical Specification 1900MHz**

Tissue Type	Return Loss:	Impedance:	SWR:
Head	-31.943	51.262	1.055U
Body	-25.099	57.750	1.119U

**System Validation Results**

Tissue	Frequency	1 Gram	10 Gram	Peak
Head	1900 MHz	39.378	19.668	77.268
Body	1900 MHz	39.654	19.668	77.268

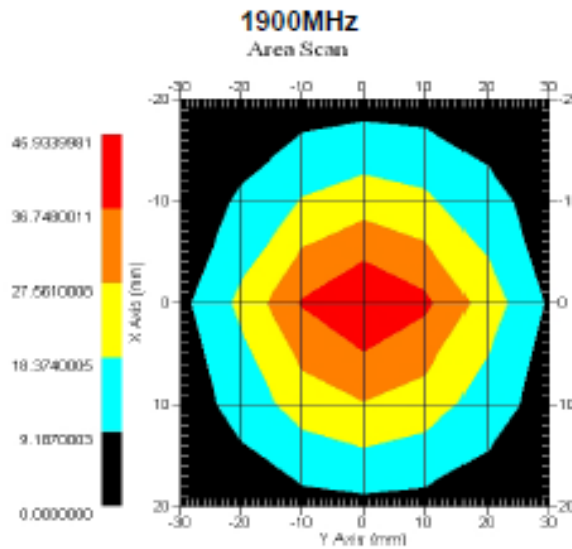

This page has been reviewed for content and attested to by signature within this document.

**NCL Calibration Laboratories**

Division of APREL Inc.

**Introduction**

This Calibration Report has been produced in line with the SSI Dipole Calibration Procedure SSI-TP-018-ALSAS. The results contained within this report are for Validation Dipole 200-00657. The calibration routine consisted of a three-step process. Step 1 was a mechanical verification of the dipole to ensure that it meets the mechanical specifications. Step 2 was an Electrical Calibration for the Validation Dipole, where the SWR, Impedance, and the Return loss were assessed. Step 3 involved a System Validation using the ALSAS-10U, along with APREL E-030 130 MHz to 26 GHz E-Field Probe Serial Number 215.

**References**

- o IEEE Standard 1528 (2003) including Amendment 1  
IEEE Recommended Practice for Determining the Peak Spatial-Average Specific Absorption Rate (SAR) in the Human Head from Wireless Communications Devices: Measurement Techniques
- o EN 62209-1 (2006)  
Human Exposure to RF Fields from hand-held and body-mounted wireless communication devices - Human models, instrumentation, and procedures-Part 1: Procedure to measure the Specific Absorption Rate (SAR) for hand-held mobile wireless devices
- o IEC 62209-2 Ed. 1.0 (2010-03)  
Human exposure to RF fields from hand-held and body-mounted wireless devices - Human models, instrumentation, and procedures - Part 2: specific absorption rate (SAR) for wireless communication devices (30 MHz - 6 GHz)
- o TP-D01-032-E020-V2 E-Field probe calibration procedure
- o D22-012-Tissue dielectric tissue calibration procedure
- o D28-002-Dipole procedure for validation of SAR system using a dipole
- o IEEE 1309 Draft Standard for Calibration of Electromagnetic Field Sensors and Probes, Excluding Antennas, from 9kHz to 40GHz

**Conditions**

Dipole 200-00657 was a re-calibration.

**Ambient Temperature of the Laboratory:** 22 °C +/- 0.5°C  
**Temperature of the Tissue:** 20 °C +/- 0.5°C

This page has been reviewed for content and attested to by signature within this document.

4

NCL Calibration Laboratories

Division of APREL Inc.

Electrical Calibration

Electrical Specification 1900MHz

Tissue Type	Measured Epsilon	Measured Sigma
Head	38.12	1.41
Body	51.52	1.57

Head Tissue

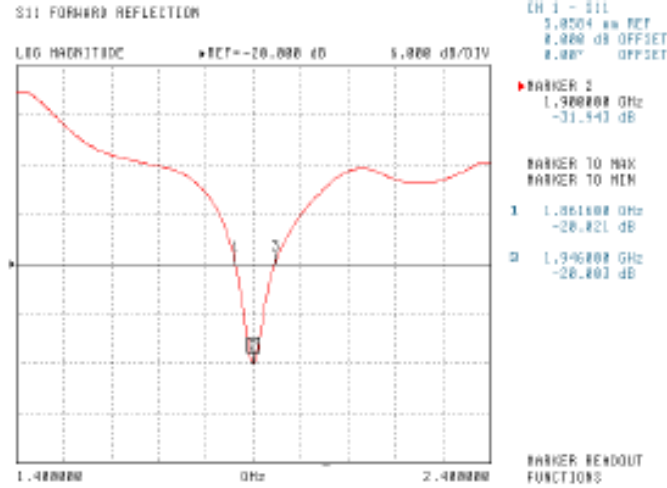

Body Tissue

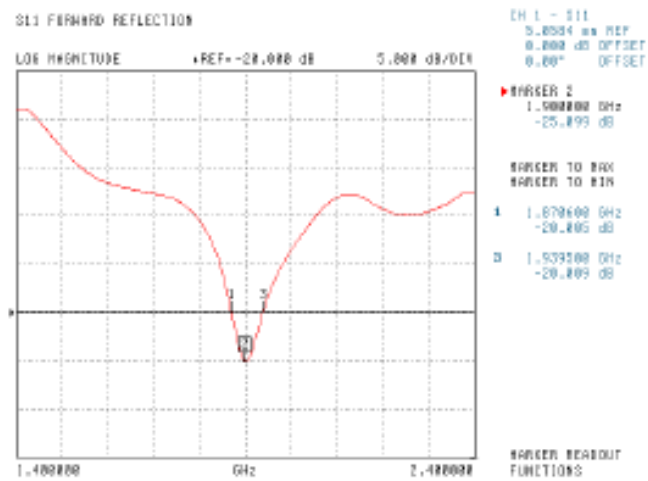

This page has been reviewed for content and attested to by signature within this document.

**NCL Calibration Laboratories**  
 Division of APREL Inc.

**Electrical Specification 1900MHz  
 Impedance**

Tissue Type	Measured Epsilon	Measured Sigma
Head	38.12	1.41
Body	51.52	1.57

**Head Tissue**

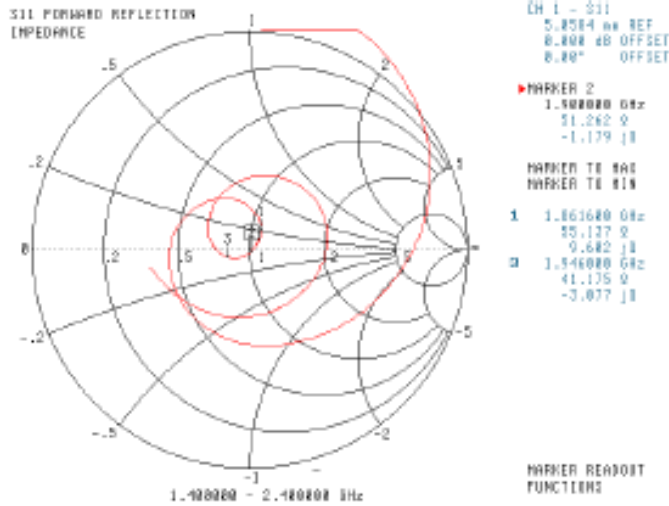

**Body Tissue**

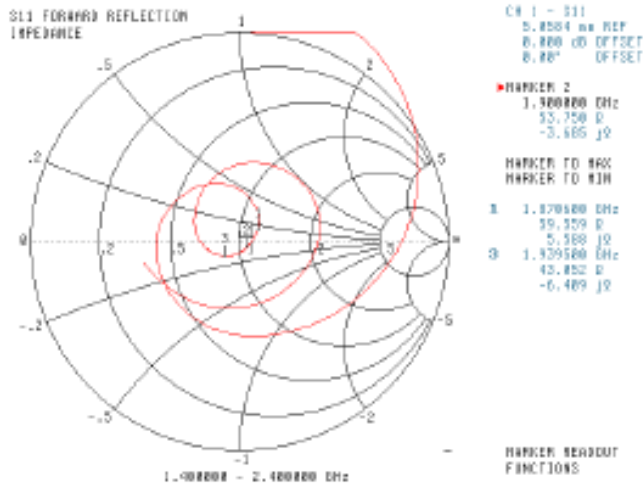

This page has been reviewed for content and attested to by signature within this document.

**NCL Calibration Laboratories**

Division of APREL Inc.

**Electrical Specification 1900MHz  
Standing Wave Ratio**

Tissue Type	Measured Epsilon	Measured Sigma
Head	38.12	1.41
Body	51.52	1.57

**Head Tissue**

S11 FORWARD REFLECTION

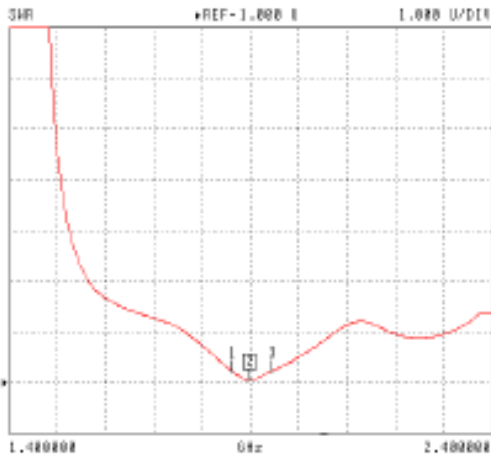

CH 1 - S11  
5.0504 uW REF  
0.000 dB OFFSET  
0.00" OFFSET

MARKER 2  
1.946000 GHz  
1.050 U

MARKER TO MAX  
MARKER TO MIN

1 1.881600 GHz  
1.254 U

2 1.946000 GHz  
1.227 U

MARKER READOUT FUNCTIONS

**Body Tissue**

S11 FORWARD REFLECTION

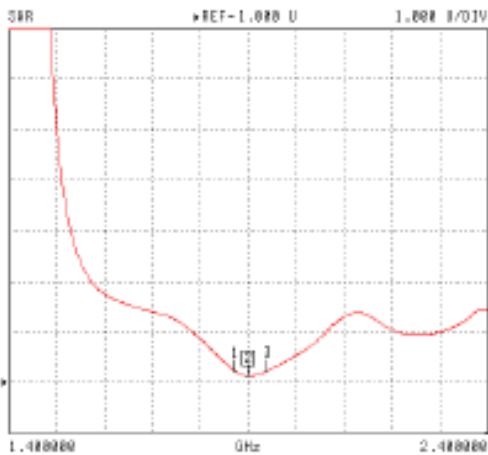

CH 1 - S11  
5.0504 uW REF  
0.000 dB OFFSET  
0.00" OFFSET

MARKER 2  
1.930500 GHz  
1.119 U

MARKER TO MAX  
MARKER TO MIN

1 1.870600 GHz  
1.232 U

2 1.930500 GHz  
1.226 U

MARKER READOUT FUNCTIONS

This page has been reviewed for content and attested to by signature within this document.

**NCL Calibration Laboratories**Division of APREL Inc.

---

**Test Equipment**

The test equipment used during Probe Calibration, manufacturer, model number and, current calibration status are listed and located on the main APREL server R:\NCL\Calibration Equipment\Instrument List May 2011.

This page has been reviewed for content and attested to by signature within this document.

8