

## FCC 47 CFR PART 15 SUBPART C

Product Type : Smartphone  
Applicant : HTC Corporation  
Address : No. 23, Xinghua Rd., Taoyuan City, Taoyuan County 330,  
Taiwan  
Trade Name : HTC  
Model Number : PC10110  
Test Specification : FCC 47 CFR PART 15 SUBPART C: Oct., 2009  
ANSI C63.4-2003  
Issue Date : Sep. 01, 2010

### Issue by

A Test Lab Techno Corp.  
No. 140-1, Changan Street, Bade City,  
Taoyuan County 334, Taiwan R.O.C.  
Tel : +886-3-2710188 / Fax : +886-3-2710190



Taiwan Accreditation Foundation accreditation number: 1330

**Note:** This report shall not be reproduced except in full, without the written approval of A Test Lab Techno Corp. This document may be altered or revised by A Test Lab Techno Corp. personnel only, and shall be noted in the revision section of the document. The client should not use it to claim product endorsement by TAF, or any government agencies. The test results in the report only apply to the tested sample.

**Revision History**

<b>Rev.</b>	<b>Issue Date</b>	<b>Revisions</b>	<b>Revised By</b>
00	Sep. 01, 2010	Initial Issue	

## Verification

Issued Date: 2010/09/01

Product Type : Smartphone  
Applicant : HTC Corporation  
Address : No. 23, Xinghua Rd., Taoyuan City, Taoyuan County 330,  
Taiwan  
Trade Name : HTC  
Model Number : PC10110  
FCC ID : NM8PC10110  
EUT Rated Voltage : DC 5.0V, 1.0A  
Test Voltage : 120 Vac / 60 Hz  
Applicable Standard : FCC 47 CFR PART 15 SUBPART C: Oct., 2009  
ANSI C63.4-2003  
Test Result : Complied  
Performing Lab. : A Test Lab Techno Corp.

No. 140-1, Changan Street, Bade City,  
Taoyuan County 334, Taiwan R.O.C.

Tel : +886-3-2710188 / Fax : +886-3-2710190

Taiwan Accreditation Foundation accreditation number:  
1330



<http://www.atl-lab.com.tw/e-index.htm>

The above equipment was tested by A Test Lab Techno Corp. The test data, data evaluation, test procedures, and equipment configurations shown in this report were made in accordance with the procedures given in ANSI C63.4: 2003 and the energy emitted by the sample tested as described in this report is in compliance with the requirements of FCC Rules Part 15.207, 15.209, 15.247 .  
The test results of this report relate only to the tested sample identified in this report.

Approved By :  
(Manager)

  
(Miller Lee )

Reviewed By :  
(Testing Engineer)

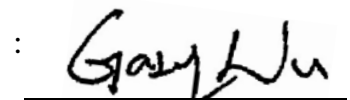
  
(Gary Wu)

## TABLE OF CONTENTS

<b>1</b>	<b>General Information .....</b>	<b>6</b>
<b>2</b>	<b>EUT Description .....</b>	<b>7</b>
<b>3</b>	<b>Test Methodology.....</b>	<b>8</b>
3.1.	Mode of Operation .....	8
3.2.	EUT Exercise Software.....	9
3.3.	Configuration of Test System Details.....	9
3.4.	Test Site Environment.....	9
<b>4</b>	<b>Conducted Emission Measurement .....</b>	<b>10</b>
4.1.	Limit .....	10
4.2.	Test Instruments .....	10
4.3.	Test Setup.....	10
4.4.	Test Procedure.....	11
4.5.	Test Result.....	12
<b>5</b>	<b>Radiated Interference Measurement .....</b>	<b>16</b>
5.1.	Limit .....	16
5.2.	Test Instruments .....	16
5.3.	Setup .....	17
5.4.	Test Procedure.....	17
5.5.	Test Result.....	19
<b>6</b>	<b>Maximum Conducted Output Power Measurement.....</b>	<b>25</b>
6.1.	Limit .....	25
6.2.	Test Setup.....	25
6.3.	Test Instruments .....	25
6.4.	Test Procedure.....	25
6.5.	Test Result.....	26
<b>7</b>	<b>Minimum 20dB RF Bandwidth Measurement .....</b>	<b>28</b>
7.1.	Limit .....	28
7.2.	Test Setup.....	28
7.3.	Test Instruments .....	28
7.4.	Test Procedure.....	28
7.5.	Test Result.....	29
7.6.	Test Graphs .....	30
<b>8</b>	<b>Carrier Frequency Separation Measurement .....</b>	<b>32</b>
8.1.	Limit .....	32
8.2.	Test Setup.....	32
8.3.	Test Instruments .....	32
8.4.	Test Procedure.....	33
8.5.	Test Result.....	34
8.6.	Test Graphs .....	35

<b>9</b>	<b>Number of Hopping Measurement .....</b>	<b>36</b>
9.1.	Limit .....	36
9.2.	Test Setup.....	36
9.3.	Test Instruments .....	36
9.4.	Test Procedure.....	36
9.5.	Test Result.....	37
9.6.	Test Graphs .....	38
<b>10</b>	<b>Time of Occupancy (Dwell Time) Measurement.....</b>	<b>40</b>
10.1.	Limit .....	40
10.2.	Test Setup.....	40
10.3.	Test Instruments .....	40
10.4.	Test Procedure.....	40
10.5.	Test Result.....	41
10.6.	Test Graphs .....	43
<b>11</b>	<b>Out of Band Conducted Emissions Measurement .....</b>	<b>45</b>
11.1.	Limit .....	45
11.2.	Test Setup.....	45
11.3.	Test Instruments .....	45
11.4.	Test Procedure.....	45
11.5.	Test Graphs .....	46
<b>12</b>	<b>Band Edges Measurement .....</b>	<b>48</b>
12.1.	Limit .....	48
12.2.	Test Setup.....	48
12.3.	Test Instruments .....	48
12.4.	Test Procedure.....	49
12.5.	Test Result.....	50
<b>13</b>	<b>99 % Occupied Bandwidth Measurement .....</b>	<b>58</b>
13.1.	Limit .....	58
13.2.	Test Setup.....	58
13.3.	Test Instruments .....	58
13.4.	Test Procedure.....	58
13.5.	Test Result.....	59
13.6.	Test Graphs .....	60
<b>14</b>	<b>Antenna Measurement.....</b>	<b>62</b>
14.1.	Limit .....	62
14.2.	Antenna Connector Construction .....	62

## 1 General Information

### 1.1 Summary of Test Result

Standard		Item	Result	Remark
15.247	RSS-GEN			
15.207	7.2.2	AC Power Conducted Emission	PASS	----
----	6	Receiver Radiated Emissions	PASS	----
Standard		Item	Result	Remark
15.247	RSS-210			
15.247(c)	A8.5	Transmitter Radiated Emissions	PASS	----
15.247(b)(1)	A8.4 (2)	Max. Output Power	PASS	----
15.247(a)(1)	A8.1 (1)	20dB RF Bandwidth	PASS	----
15.247(a)(1)(iii)	A8.1 (2)	Carrier Frequency Separation	PASS	----
15.247(a)(1)(iii)	A8.1 (4)	Number of Hopping	PASS	----
15.247(a)(1)(iii)	A8.1 (4)	Time of Occupancy (Dwell Time)	PASS	----
15.247(c)	A8.5	Out of Band Conducted Spurious Emission	PASS	----
15.247(c)	A8.5	Band Edge Measurement	PASS	----
15.203	-	Antenna Requirement	PASS	----

The test results of this report relate only to the tested sample(s) identified in this report. Manufacturer or whom it may concern should recognize the pass or fail of the test result.

### 1.2 Measurement Uncertainty

#### Conducted Emission

The measurement uncertainty is evaluated as  $\pm 2.24$  dB.

#### Radiated Emission

The measurement uncertainty of 30 MHz - 1GHz is evaluated as  $\pm 3.072$ dB.

## 2 EUT Description

Product	:	Smartphone		
Trade Name	:	HTC		
Model Number	:	PC10110		
IMEI Number	:	352212040000015		
Applicant	:	HTC Corporation No. 23, Xinghua Rd., Taoyuan City, Taoyuan County 330, Taiwan		
Manufacturer	:	HTC Corporation No. 23, Xinghua Rd., Taoyuan City, Taoyuan County 330, Taiwan		
FCC ID	:	NM8PC10110		
Frequency Range	:	2402 ~ 2480 MHz		
Modulation Type	:	GFSK for 1Mbps		
		$\pi/4$ -DQPSK for 2Mbps		
		8DPSK for 3Mbps		
Antenna Type	:	PIFA Type		
Antenna Gain	:	1.69 dBi		
RF Output Power (Conducted)	:	GFSK for 1Mbps	0.46 dBm /	0.00111 W
		$\pi/4$ -DQPSK for 2Mbps	3.31 dBm /	0.00214 W
		8DPSK for 3Mbps	1.22 dBm /	0.00132 W

### 3 Test Methodology

#### 3.1. Mode of Operation

Decision of Test ATL has verified the construction and function in typical operation. All the test modes were carried out with the EUT in normal operation, which was shown in this test report and defined as:

Test Mode
Mode 1: IDLE Mode
Mode 2: Normal Operation Mode
Mode 3: GFSK Link Mode
Mode 4: $\pi/4$ -DQPSK Link Mode
Mode 5: 8DPSK Link Mode
Mode 6: Receiver Mode

#### Description of Test Modes

Preliminary tests were performed in different modulation to find the worst case. The modulation shown in the table below is the worst-case. Investigation has been done on all the possible configurations for searching the worst cases. The following table is a list of the test modes shown in this test report.

Modulation Type	Channel	Frequency (MHz)	Packet Type	Peak Conducted Power		Worst Case
				(dBm)	(W)	
GFSK	Low	2402	DH1	0.29	0.00107	<input type="checkbox"/>
	Low	2402	DH3	0.30	0.00107	<input type="checkbox"/>
	Low	2402	DH5	0.29	0.00107	<input type="checkbox"/>
	Middle	2441	DH1	0.35	0.00108	<input type="checkbox"/>
	Middle	2441	DH3	0.46	0.00111	<input type="checkbox"/>
	Middle	2441	DH5	0.37	0.00109	<input type="checkbox"/>
	High	2480	DH1	0.12	0.00103	<input type="checkbox"/>
	High	2480	DH3	0.13	0.00103	<input type="checkbox"/>
	High	2480	DH5	0.12	0.00103	<input type="checkbox"/>
$\pi/4$ -DQPSK	Low	2402	2DH1	3.16	0.00207	<input type="checkbox"/>
	Low	2402	2DH3	3.20	0.00209	<input type="checkbox"/>
	Low	2402	2DH5	3.17	0.00207	<input type="checkbox"/>
	Middle	2441	2DH1	3.30	0.00214	<input type="checkbox"/>
	Middle	2441	2DH3	3.31	0.00214	<input checked="" type="checkbox"/>
	Middle	2441	2DH5	3.28	0.00213	<input type="checkbox"/>
	High	2480	2DH1	3.10	0.00204	<input type="checkbox"/>
	High	2480	2DH3	3.12	0.00205	<input type="checkbox"/>
	High	2480	2DH5	3.09	0.00204	<input type="checkbox"/>
8DPSK	Low	2402	3DH1	1.08	0.00128	<input type="checkbox"/>
	Low	2402	3DH3	1.09	0.00129	<input type="checkbox"/>
	Low	2402	3DH5	0.95	0.00124	<input type="checkbox"/>
	Middle	2441	3DH1	1.10	0.00129	<input type="checkbox"/>
	Middle	2441	3DH3	1.13	0.00130	<input type="checkbox"/>
	Middle	2441	3DH5	1.22	0.00132	<input type="checkbox"/>
	High	2480	3DH1	0.83	0.00121	<input type="checkbox"/>
	High	2480	3DH3	0.84	0.00121	<input type="checkbox"/>
	High	2480	3DH5	0.86	0.00122	<input type="checkbox"/>



### Tested System Details

The types for all equipments, plus descriptions of all cables used in the tested system (including inserted cards) are:

	Product	Manufacturer	Model Number	Serial Number	Power Cord
1.	Bluetooth Tester	R & S	CBT	100350	NA

### 3.2. EUT Exercise Software

1.	Setup the EUT and Bluetooth Tester (CBT) as shown on 3.3.
2.	Turn on the power of all equipment.
3.	EUT run test program.
4.	Open Bluetooth function link to CBT.

### 3.3. Configuration of Test System Details

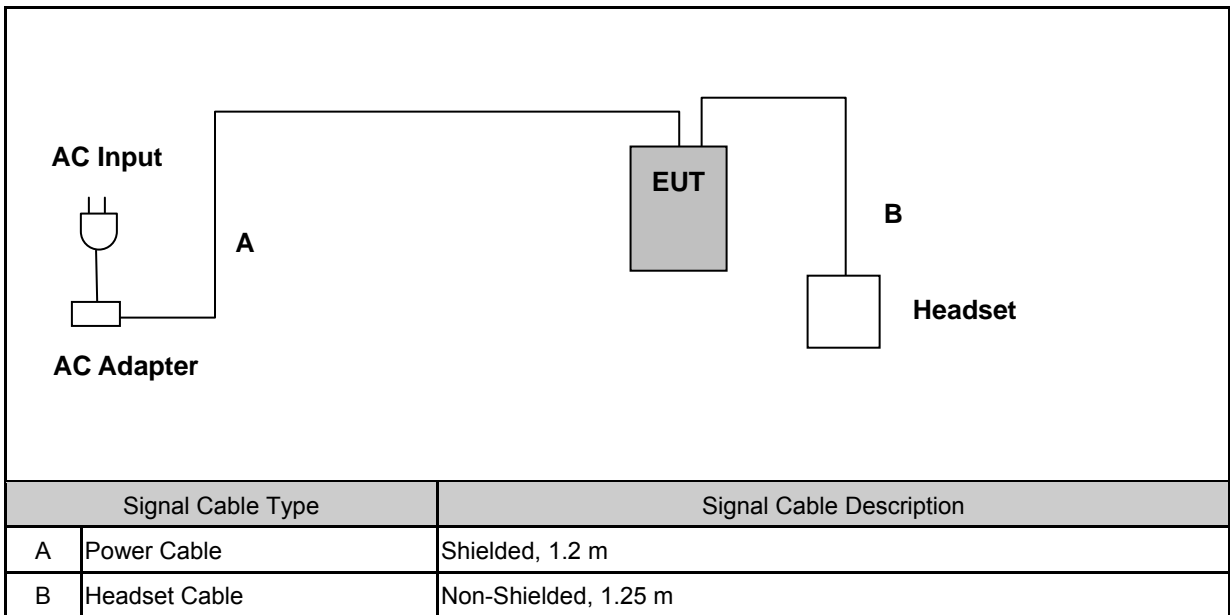

### 3.4. Test Site Environment

Items	Required (IEC 68-1)	Actual
Temperature (°C)	15-35	25
Humidity (%RH)	25-75	50
Barometric pressure (mbar)	860-1060	950

## 4 Conducted Emission Measurement

### 4.1. Limit

Frequency (MHz)	Quasi-peak	Average
0.15 - 0.5	66 to 56	56 to 46
0.50 - 5.0	56	46
5.0 - 30.0	60	50

### 4.2. Test Instruments

Describe	Manufacturer	Model Number	Serial Number	Cal. Date	Remark
Test Receiver	R&S	ESCI	100367	07/01/2010	(1)
LISN	R&S	ENV216	101040	03/02/2010	(1)
LISN	R&S	ENV216	101041	03/02/2010	(1)
Test Site	ATL	TE02	TE02	N.C.R.	-----

Remark: (1) Calibration period 1 year. (2) Calibration period 2 years.

NOTE: N.C.R. = No Calibration Request.

### 4.3. Test Setup

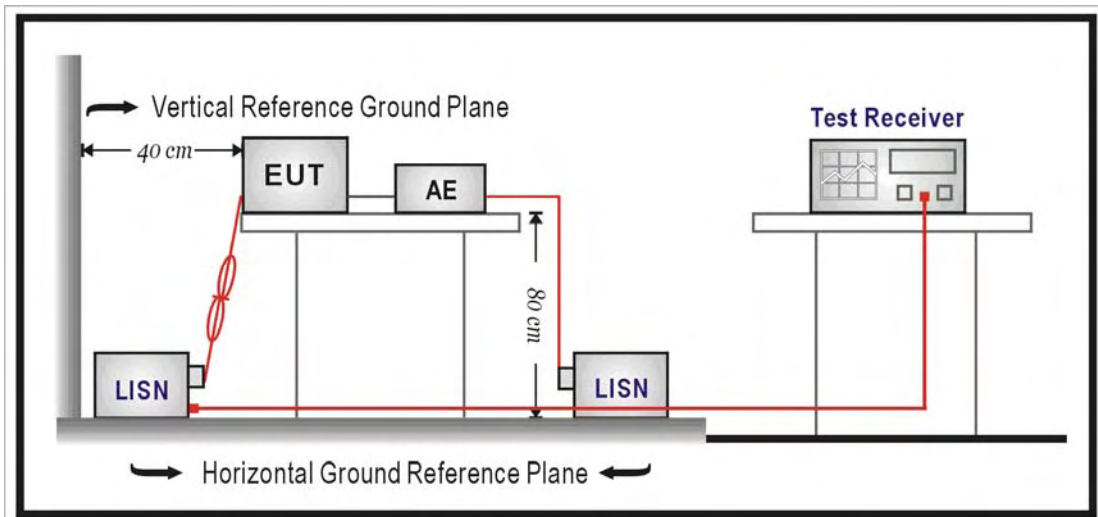

#### **4.4. Test Procedure**

The power line conducted emission measurements were performed in a shielded enclosure. The EUT was assembled on a wooden table which is 80 centimeters high, was placed 40 centimeters from the back wall and at least 1 meter from the sidewall.

Power was fed to the EUT from the public utility power grid through a line filter and EMCO Model 3162/2 SH Line Impedance Stabilization Networks (LISN). The LISN housing, measuring instrumentation case, ground plane, etc., were electrically bonded together at the same RF potential. The Spectrum analyzer was connected to the AC line through an isolation transformer. The 50-ohm output of the LISN was connected to the spectrum analyzer directly. Conducted emission levels were in the CISPR quasi-peak detection mode. The analyzer's 6 dB bandwidth was set to 9 KHz. No post-detector video filter was used.

The spectrum was scanned from 150 KHz to 30 MHz. The physical arrangement of the test system and associated cabling was varied (within the scope of arrangements likely to be encountered in actual use) to determine the effect on the unit's emanations in amplitude and frequency. All spurious emission frequencies were observed. The highest emission amplitudes relative to the appropriate limit were measured and have been recorded in paragraph 4.1.

#### 4.5. Test Result

Standard:	FCC Part 15C	Line:	L1
Test item:	Conducted Emission	Power:	AC 120V/60Hz
Model Number:	PC10110	Temp.(°C)/Hum.(%RH):	26(°C)/60%RH
Mode:	Mode 1	Date:	2010/08/11
		Test By:	Gary Wu
Description:			

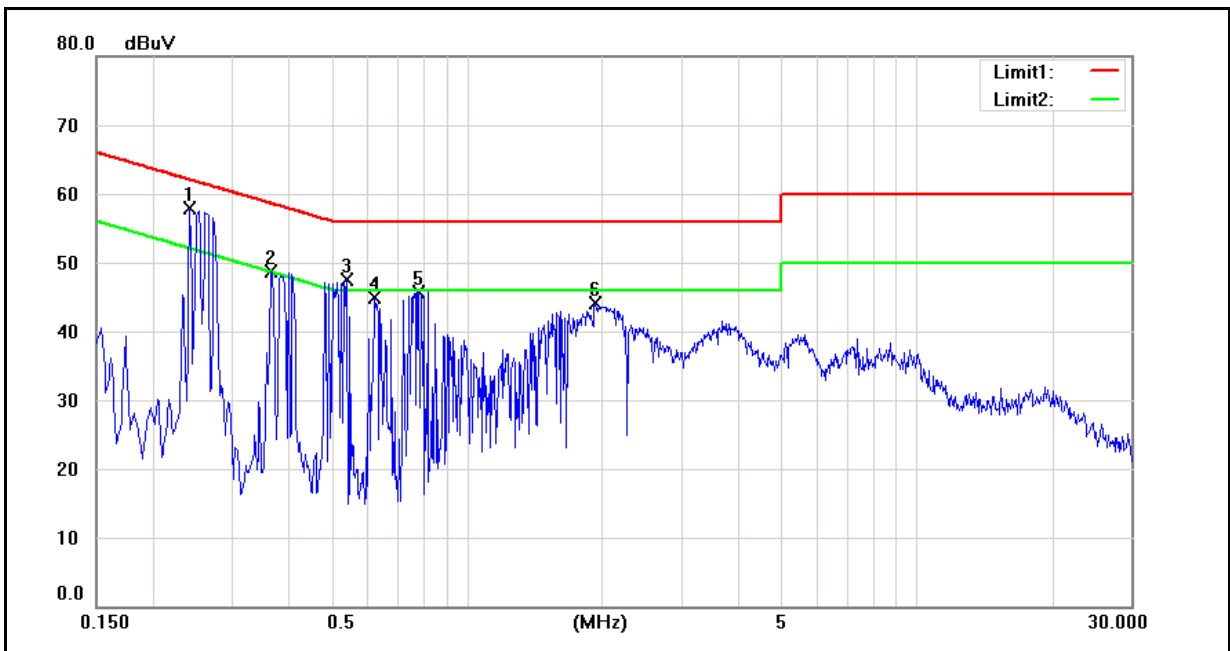

No.	Frequency (MHz)	QP reading (dBuV)	AVG reading (dBuV)	Correction factor (dB)	QP result (dBuV)	AVG result (dBuV)	QP limit (dBuV)	AVG limit (dBuV)	QP margin (dB)	AVG margin (dB)	Remark
1	0.2420	45.78	21.56	9.59	55.37	31.15	62.03	52.03	-6.66	-20.88	Pass
2	0.3660	36.39	14.03	9.59	45.98	23.62	58.59	48.59	-12.61	-24.97	Pass
3	0.5420	32.95	7.85	9.59	42.54	17.44	56.00	46.00	-13.46	-28.56	Pass
4	0.6220	30.70	7.10	9.59	40.29	16.69	56.00	46.00	-15.71	-29.31	Pass
5	0.7820	31.64	8.18	9.60	41.24	17.78	56.00	46.00	-14.76	-28.22	Pass
6	1.9300	27.60	8.69	9.61	37.21	18.30	56.00	46.00	-18.79	-27.70	Pass

Standard:	FCC Part 15C	Line:	N
Test item:	Conducted Emission	Power:	AC 120V/60Hz
Model Number:	PC10110	Temp.(°C)/Hum.(%RH):	26(°C)/60%RH
Mode:	Mode 1	Date:	2010/08/11
		Test By:	Gary Wu
Description:			

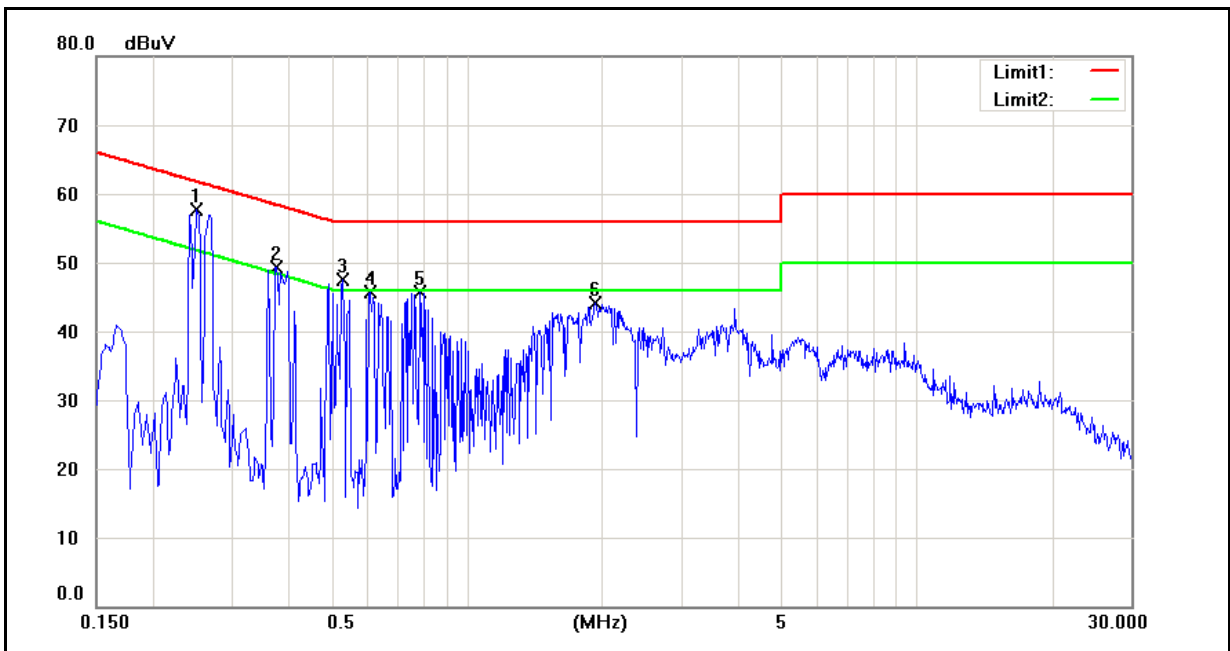

No.	Frequency (MHz)	QP reading (dBuV)	AVG reading (dBuV)	Correction factor (dB)	QP result (dBuV)	AVG result (dBuV)	QP limit (dBuV)	AVG limit (dBuV)	QP margin (dB)	AVG margin (dB)	Remark
1	0.2500	46.01	23.93	9.58	55.59	33.51	61.76	51.76	-6.17	-18.25	Pass
2	0.3780	36.34	13.19	9.59	45.93	22.78	58.32	48.32	-12.39	-25.54	Pass
3	0.5300	33.42	8.40	9.59	43.01	17.99	56.00	46.00	-12.99	-28.01	Pass
4	0.6100	31.38	8.18	9.59	40.97	17.77	56.00	46.00	-15.03	-28.23	Pass
5	0.7860	31.61	7.59	9.59	41.20	17.18	56.00	46.00	-14.80	-28.82	Pass
6	1.9340	27.51	7.28	9.60	37.11	16.88	56.00	46.00	-18.89	-29.12	Pass

Standard:	FCC Part 15C	Line:	L1
Test item:	Conducted Emission	Power:	AC 120V/60Hz
Model Number:	PC10110	Temp.(°C)/Hum.(%RH):	26(°C)/60%RH
Mode:	Mode 2	Date:	2010/08/11
		Test By:	Gary Wu
Description:			

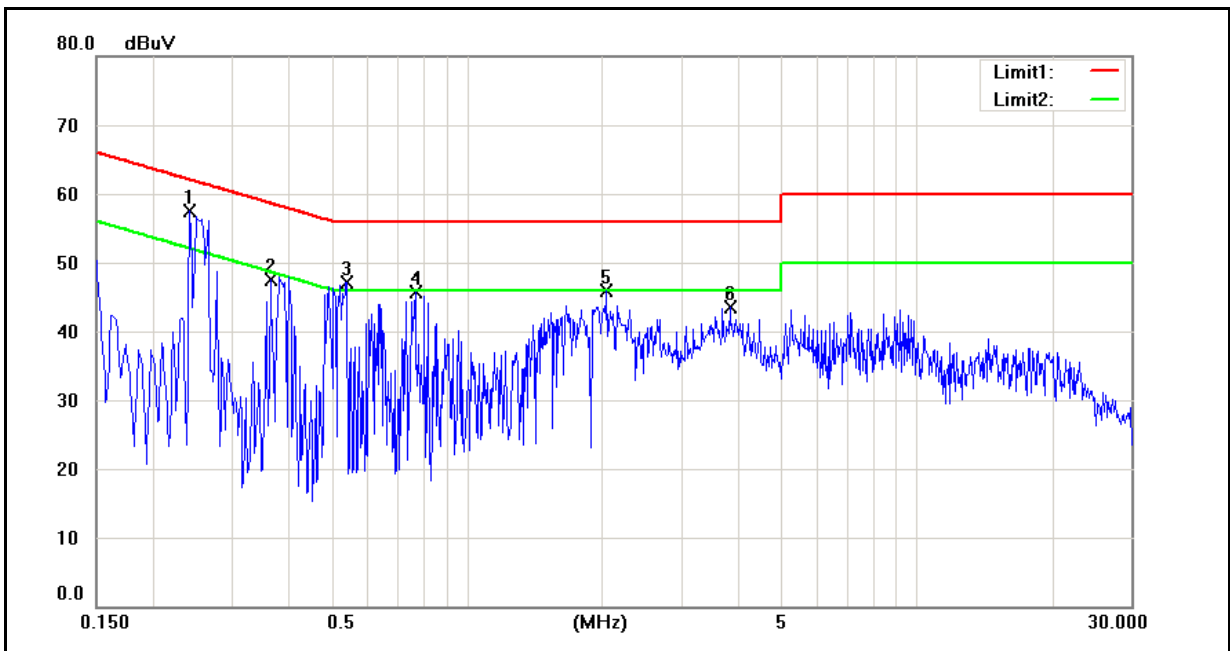

No.	Frequency (MHz)	QP reading (dBuV)	AVG reading (dBuV)	Correction factor (dB)	QP result (dBuV)	AVG result (dBuV)	QP limit (dBuV)	AVG limit (dBuV)	QP margin (dB)	AVG margin (dB)	Remark
1	0.2420	44.48	17.49	9.59	54.07	27.08	62.03	52.03	-7.96	-24.95	Pass
2	0.3660	34.41	10.91	9.59	44.00	20.50	58.59	48.59	-14.59	-28.09	Pass
3	0.5420	30.57	4.99	9.59	40.16	14.58	56.00	46.00	-15.84	-31.42	Pass
4	0.7700	34.58	17.15	9.60	44.18	26.75	56.00	46.00	-11.82	-19.25	Pass
5	2.0500	33.85	16.06	9.61	43.46	25.67	56.00	46.00	-12.54	-20.33	Pass
6	3.8460	30.68	11.16	9.63	40.31	20.79	56.00	46.00	-15.69	-25.21	Pass

Standard:	FCC Part 15C	Line:	N
Test item:	Conducted Emission	Power:	AC 120V/60Hz
Model Number:	PC10110	Temp.(°C)/Hum.(%RH):	26(°C)/60%RH
Mode:	Mode 2	Date:	2010/08/11
		Test By:	Gary Wu
Description:			

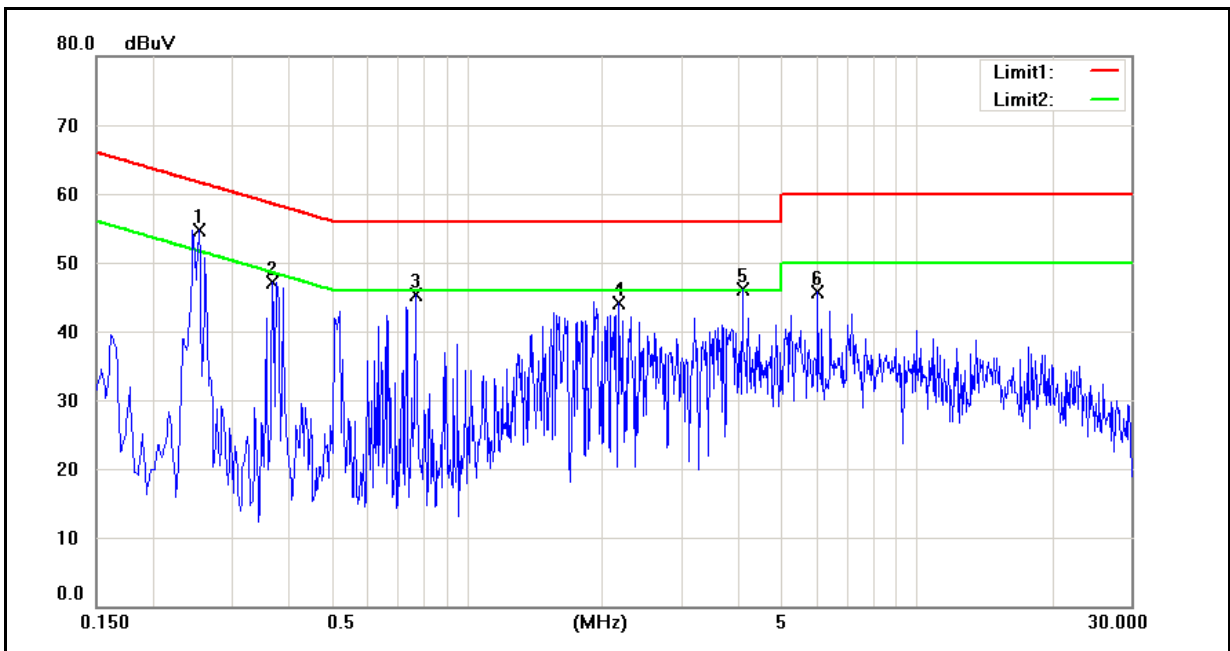

No.	Frequency (MHz)	QP reading (dBuV)	AVG reading (dBuV)	Correction factor (dB)	QP result (dBuV)	AVG result (dBuV)	QP limit (dBuV)	AVG limit (dBuV)	QP margin (dB)	AVG margin (dB)	Remark
1	0.2540	43.17	25.03	9.58	52.75	34.61	61.63	51.63	-8.88	-17.02	Pass
2	0.3700	32.78	10.28	9.59	42.37	19.87	58.50	48.50	-16.13	-28.63	Pass
3	0.7700	34.07	17.04	9.59	43.66	26.63	56.00	46.00	-12.34	-19.37	Pass
4	2.1820	31.43	13.02	9.60	41.03	22.62	56.00	46.00	-14.97	-23.38	Pass
5	4.1060	27.80	10.66	9.62	37.42	20.28	56.00	46.00	-18.58	-25.72	Pass
6	6.0300	25.08	7.97	9.65	34.73	17.62	60.00	50.00	-25.27	-32.38	Pass

## 5 Radiated Interference Measurement

### 5.1. Limit

Frequency Range (MHz)	Peak (dBuV)
30 to 88	39
88 to 216	43.5
216 to 960	46.4
Above 960	49.5

### 5.2. Test Instruments

3 Meter Chamber					
Equipment	Manufacturer	Model Number	Serial Number	Cal. Date	Remark
RF Pre-selector	Agilent	N9039A	MY46520256	01/07/2009	(2)
Spectrum Analyzer	Agilent	E4446A	MY46180578	02/24/2010	(1)
Pre Amplifier	Agilent	8449B	3008A02237	02/24/2010	(1)
Pre Amplifier	Agilent	8447D	2944A10961	02/24/2010	(1)
Bi-log Antenna	SCHWARZBECK MESS-ELEKTRONIK	VULB9163	9163-270	08/02/2010	(1)
Horn Antenna	SCHWARZBECK MESS-ELEKTRONIK	BBHA9120D	9120D-550	06/29/2010	(1)
Horn Antenna	SCHWARZBECK MESS-ELEKTRONIK	BBHA9170	9170-320	06/29/2010	(1)
Test Site	ATL	TE01	888001	07/30/2010	(1)

Remark: (1) Calibration period 1 year. (2) Calibration period 2 years.

NOTE: N.C.R. = No Calibration Request.



### 5.3. Setup

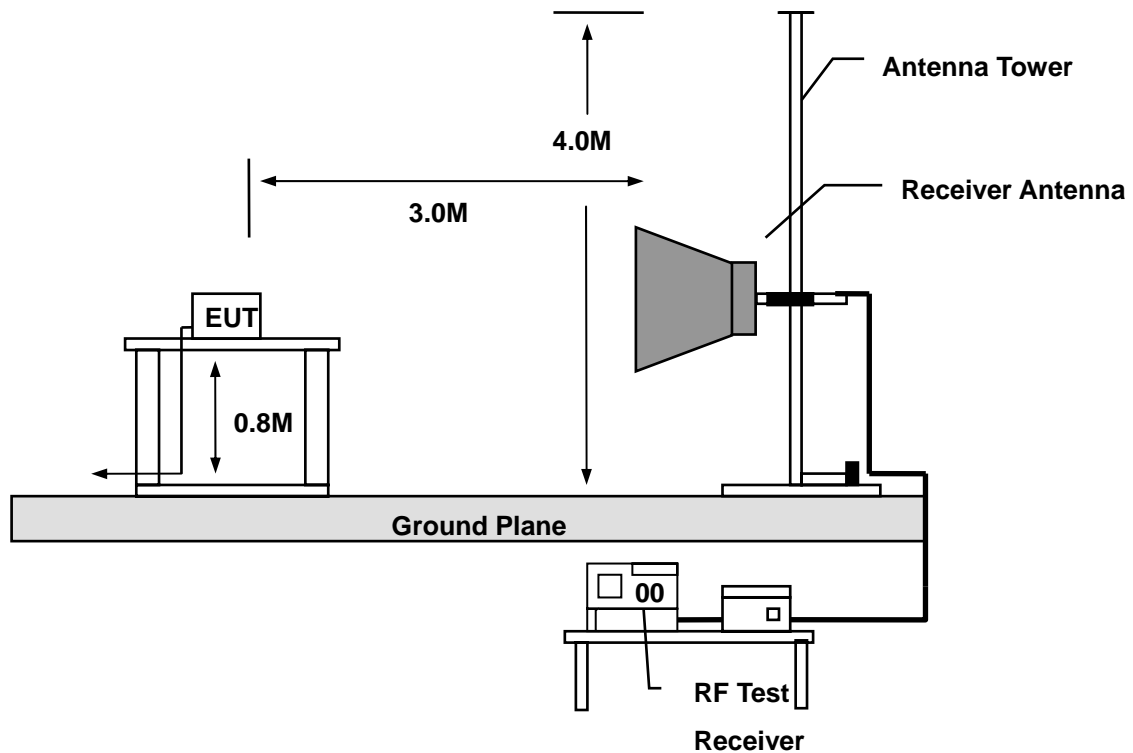

### 5.4. Test Procedure

Final radiation measurements were made on a three-meter, Semi Anechoic Chamber. The EUT system was placed on a nonconductive turntable which is 0.8 meters height, top surface 1.0 x 1.5 meter. The spectrum was examined from 250 MHz to 2.5 GHz in order to cover the whole spectrum below 10th harmonic which could generate from the EUT. During the test, EUT was set to transmit continuously & Measurements spectrum range from 30 MHz to 26.5 GHz is investigated.

For measurements below 1 GHz the resolution bandwidth is set to 100 kHz for peak detection measurements or 120 kHz for quasi-peak detection measurements. Peak detection is used unless otherwise noted as quasi-peak.

For measurements above 1 GHz the resolution bandwidth is set to 1 MHz, and then the video bandwidth is set to 1 MHz for peak measurements and 10 Hz for average measurements.

A nonconductive material surrounded the EUT to supporting the EUT for standing on three orthogonal planes. At each condition, the EUT was rotated 360 degrees, and the antenna was raised and lowered from one to four meters to find the maximum emission levels. Measurements were taken using both horizontal and vertical antenna polarization.

SCHWARZBECK MESS-ELEKTRONIK Biconilog Antenna (model VULB9163) at 3 Meter and the SCHWARZBECK Double Ridged Guide Antenna (model BBHA9120D&9170) was used in frequencies 1 – 26.5 GHz at a distance of 1 meter. All test results were extrapolated to equivalent signal at 3 meters utilizing an inverse linear distance extrapolation Factor (20dB/decade).

For testing above 1GHz, the emission level of the EUT in peak mode was 20dB lower than average limit (that means the emission level in peak mode also complies with the limit in average mode), then testing will be stopped and peak values of EUT will be reported, otherwise, the emissions will be measured in average mode again and reported.

Appropriate preamplifiers were used for improving sensitivity and precautions were taken to avoid overloading or desensitizing the spectrum analyzer. No post – detector video filters were used in the test.

The spectrum analyzer's 6 dB bandwidth was set to 1 MHz, and the analyzer was operated in the peak detection mode, for frequencies both below and up 1 GHz. The average levels were obtained by subtracting the duty cycle correction factor from the peak readings.

The following procedures were used to convert the emission levels measured in decibels referenced to 1 microvolt (dBuV) into field intensity in micro volts pre meter (uV/m).

The actual field intensity in decibels referenced to 1 microvolt in to field intensity in micro volts per meter (dBuV/m).

The actual field intensity in referenced to 1 microvolt per meter (dBuV/m) is determined by algebraically adding the measured reading in dBuV, the antenna factor (dB), and cable loss (dB) and Subtracting the gain of preamplifier (dB) is auto calculate in spectrum analyzer.

$$(1) \text{ Amplitude (dBuV/m) = FI (dBuV) +AF (dBuV) +CL (dBuV)-Gain (dB)}$$

FI= Reading of the field intensity.

AF= Antenna factor.

CL= Cable loss.

P.S Amplitude is auto calculate in spectrum analyzer.

$$(2) \text{ Actual Amplitude (dBuV/m) = Amplitude (dBuV)-Dis(dB)}$$

The FCC specified emission limits were calculated according the EUT operating frequency and by following linear interpolation equations:

(a) For fundamental frequency : Transmitter Output < +30dBm

(b) For spurious frequency : Spurious emission limits = fundamental emission limit /10

## 5.5. Test Result

### Below 1GHz

Standard:	FCC Part 15C	Test Distance:	3m
Test item:	Radiated Emission	Power:	AC 120V/60Hz
Model Number:	PC10110	Temp.(°C)/Hum.(%RH):	26(°C)/60%RH
Mode:	Mode 2	Date:	2010/08/12
Ant.Polar.:	Horizontal	Test By:	Gary Wu

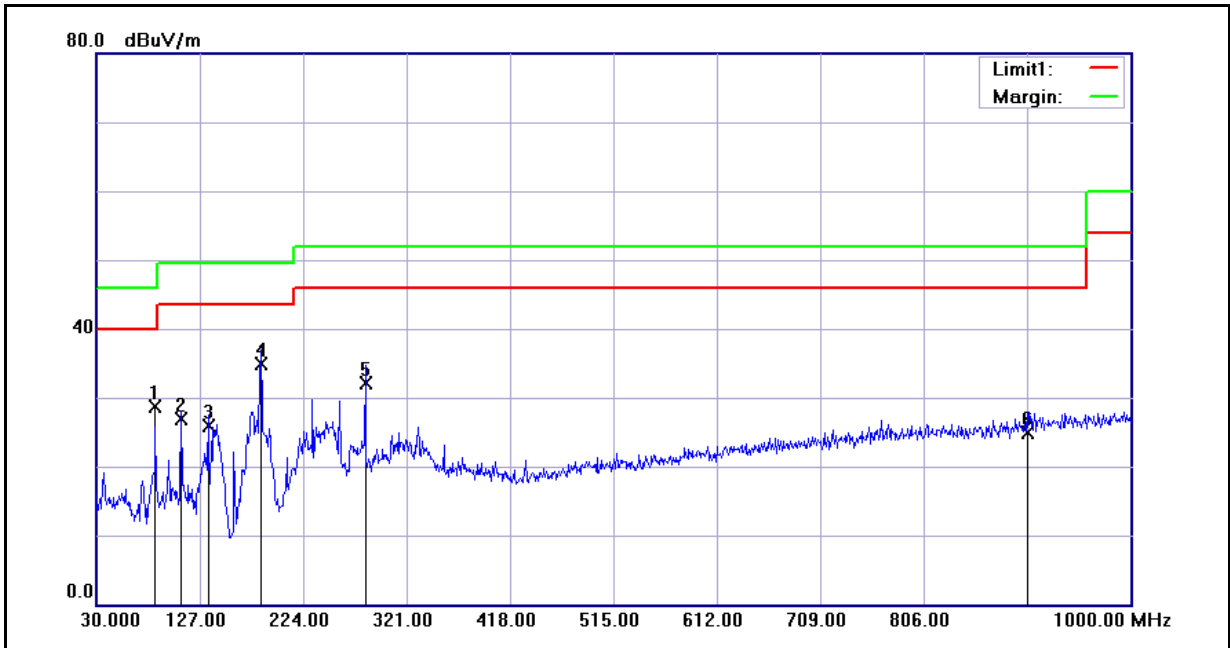

No.	Frequency (MHz)	Reading (dBuV)	Correct Factor(dB/m)	Result (dBuV/m)	Limit (dBuV/m)	Margin (dB)	Remark
1	86.0000	45.72	-16.95	28.77	40.00	-11.23	QP
2	110.5000	41.01	-14.16	26.85	43.50	-16.65	QP
3	135.0000	42.82	-16.96	25.86	43.50	-17.64	QP
4	184.5000	49.59	-14.75	34.84	43.50	-8.66	QP
5	282.5000	43.15	-11.00	32.15	46.00	-13.85	QP
6	903.5000	24.59	0.27	24.86	46.00	-21.14	QP

Standard:	FCC Part 15C	Test Distance:	3m
Test item:	Radiated Emission	Power:	AC 120V/60Hz
Model Number:	PC10110	Temp.(°C)/Hum.(%RH):	26(°C)/60%RH
Mode:	Mode 2	Date:	2010/08/12
Ant.Polar.:	Vertical	Test By:	Gary Wu

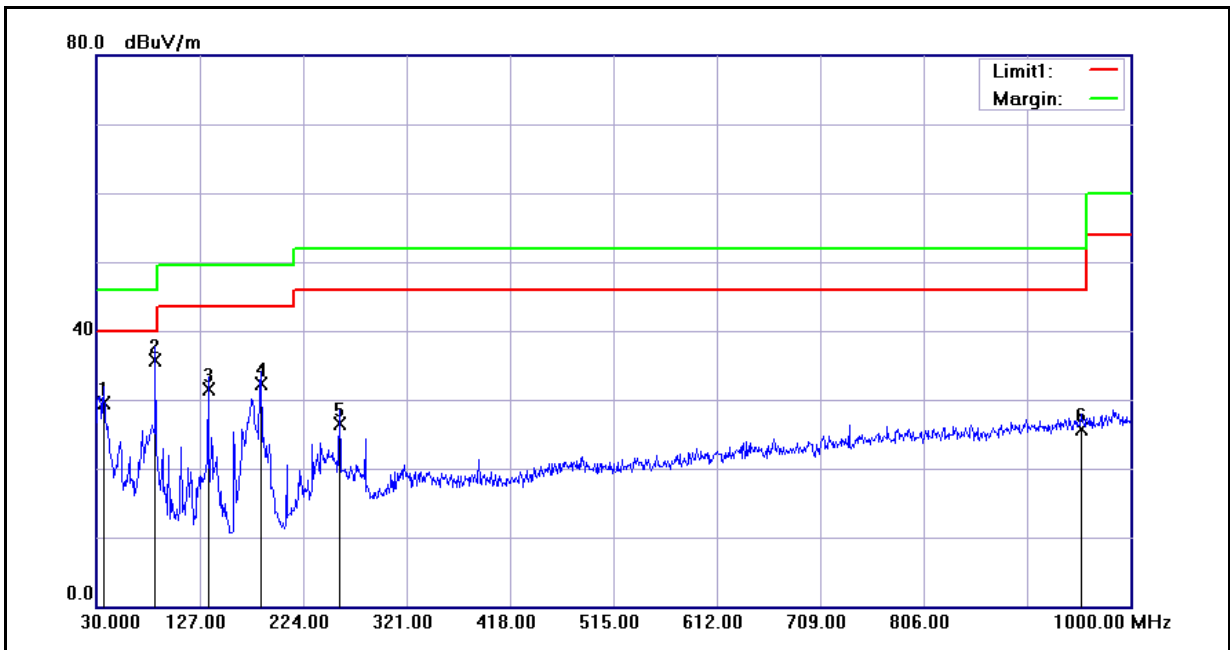

No.	Frequency (MHz)	Reading (dBuV)	Correct Factor(dB/m)	Result (dBuV/m)	Limit (dBuV/m)	Margin (dB)	Remark
1	37.0000	42.27	-12.73	29.54	40.00	-10.46	QP
2	86.0000	52.64	-16.95	35.69	40.00	-4.31	QP
3	135.0000	48.48	-16.96	31.52	43.50	-11.98	QP
4	184.5000	47.11	-14.75	32.36	43.50	-11.14	QP
5	258.0000	38.42	-11.84	26.58	46.00	-19.42	QP
6	953.5000	24.77	0.97	25.74	46.00	-20.26	QP

**Above 1GHz**

Standard:	FCC Part 15C			Test Distance:	3m		
Test item:	Radiated Emission			Power:	AC 120V/60Hz		
Model Number:	PC10110			Temp.(°C)/Hum.(%RH):	26(°C)/60%RH		
Mode:	Mode 3			Date:	2010/08/12		
Frequency:	2402 MHz			Test By:	Gary Wu		
Frequency (MHz)	Reading (dBuV)	Correct Factor(dB/m)	Result (dBuV/m)	Limit (dBuV/m)	Margin (dB)	Remark	Ant.Polar. H / V
4804.000	36.46	7.86	44.32	74.00	-29.68	peak	H
7206.000	35.37	14.96	50.33	74.00	-23.67	peak	H
4804.000	35.90	7.86	43.76	74.00	-30.24	peak	V
7206.000	35.25	14.96	50.21	74.00	-23.79	peak	V

Standard:	FCC Part 15C			Test Distance:	3m		
Test item:	Radiated Emission			Power:	AC 120V/60Hz		
Model Number:	PC10110			Temp.(°C)/Hum.(%RH):	26(°C)/60%RH		
Mode:	Mode 3			Date:	2010/08/12		
Frequency:	2441 MHz			Test By:	Gary Wu		
Frequency (MHz)	Reading (dBuV)	Correct Factor(dB/m)	Result (dBuV/m)	Limit (dBuV/m)	Margin (dB)	Remark	Ant.Polar. H / V
4882.000	35.61	8.11	43.72	74.00	-30.28	peak	H
7323.000	34.77	15.26	50.03	74.00	-23.97	peak	H
4882.000	36.18	8.11	44.29	74.00	-29.71	peak	V
7323.000	34.44	15.26	49.70	74.00	-24.30	peak	V

Standard:	FCC Part 15C			Test Distance:	3m		
Test item:	Radiated Emission			Power:	AC 120V/60Hz		
Model Number:	PC10110			Temp.(°C)/Hum.(%RH):	26(°C)/60%RH		
Mode:	Mode 3			Date:	2010/08/12		
Frequency:	2480 MHz			Test By:	Gary Wu		
Frequency (MHz)	Reading (dBuV)	Correct Factor(dB/m)	Result (dBuV/m)	Limit (dBuV/m)	Margin (dB)	Remark	Ant.Polar. H / V
4960.000	37.15	8.36	45.51	74.00	-28.49	peak	H
7440.000	35.62	15.57	51.19	74.00	-22.81	peak	H
4960.000	36.17	8.36	44.53	74.00	-29.47	peak	V
7440.000	35.06	15.57	50.63	74.00	-23.37	peak	V

Standard:	FCC Part 15C			Test Distance:	3m		
Test item:	Radiated Emission			Power:	AC 120V/60Hz		
Model Number:	PC10110			Temp.(°C)/Hum.(%RH):	26(°C)/60%RH		
Mode:	Mode 4			Date:	2010/08/12		
Frequency:	2402 MHz			Test By:	Gary Wu		
Frequency (MHz)	Reading (dBuV)	Correct Factor(dB/m)	Result (dBuV/m)	Limit (dBuV/m)	Margin (dB)	Remark	Ant.Polar. H / V
4804.000	37.03	7.86	44.89	74.00	-29.11	peak	H
7206.000	35.69	14.96	50.65	74.00	-23.35	peak	H
4804.000	36.64	7.86	44.50	74.00	-29.50	peak	V
7206.000	36.49	14.96	51.45	74.00	-22.55	peak	V

Standard:	FCC Part 15C			Test Distance:	3m		
Test item:	Radiated Emission			Power:	AC 120V/60Hz		
Model Number:	PC10110			Temp.(°C)/Hum.(%RH):	26(°C)/60%RH		
Mode:	Mode 4			Date:	2010/08/12		
Frequency:	2441 MHz			Test By:	Gary Wu		
Frequency (MHz)	Reading (dBuV)	Correct Factor(dB/m)	Result (dBuV/m)	Limit (dBuV/m)	Margin (dB)	Remark	Ant.Polar. H / V
4882.000	36.42	8.11	44.53	74.00	-29.47	peak	H
7323.000	34.74	15.26	50.00	74.00	-24.00	peak	H
4882.000	36.92	8.11	45.03	74.00	-28.97	peak	V
7323.000	35.73	15.26	50.99	74.00	-23.01	peak	V

Standard:	FCC Part 15C			Test Distance:	3m		
Test item:	Radiated Emission			Power:	AC 120V/60Hz		
Model Number:	PC10110			Temp.(°C)/Hum.(%RH):	26(°C)/60%RH		
Mode:	Mode 4			Date:	2010/08/12		
Frequency:	2480 MHz			Test By:	Gary Wu		
Frequency (MHz)	Reading (dBuV)	Correct Factor(dB/m)	Result (dBuV/m)	Limit (dBuV/m)	Margin (dB)	Remark	Ant.Polar. H / V
4960.000	36.14	8.36	44.50	74.00	-29.50	peak	H
7440.000	34.86	15.57	50.43	74.00	-23.57	peak	H
4960.000	36.09	8.36	44.45	74.00	-29.55	peak	V
7440.000	35.54	15.57	51.11	74.00	-22.89	peak	V

Standard:	FCC Part 15B	Test Distance:	3m
Test item:	Radiated Emission	Power:	AC 120V/60Hz
Model Number:	PC10110	Temp.(°C)/Hum.(%RH):	26(°C)/60%RH
Mode:	Mode 6	Date:	2010/08/12
Modulation:	$\pi/4$ -DQPSK	Test By:	Gary Wu
Frequency:	2441 MHz		

Frequency (MHz)	Reading (dBuV)	Correct Factor(dB/m)	Result (dBuV/m)	Peak Limit (dBuV/m)	AVG. Limit (dBuV/m)	Margin (dB)	Remark	Ant.Polar. H / V
3128.000	40.37	2.59	42.96	74.00	54.00	-31.04	peak	H
7111.000	36.99	14.70	51.69	74.00	54.00	-22.31	peak	H
3121.000	39.67	2.57	42.24	74.00	54.00	-31.76	peak	V
7356.000	36.21	15.35	51.56	74.00	54.00	-22.44	peak	V



## 6 Maximum Conducted Output Power Measurement

### 6.1. Limit

For frequency hopping systems operating in the 2400–2483.5 MHz band employing at least 75 non-overlapping hopping channels < 1 watt.

### 6.2. Test Setup

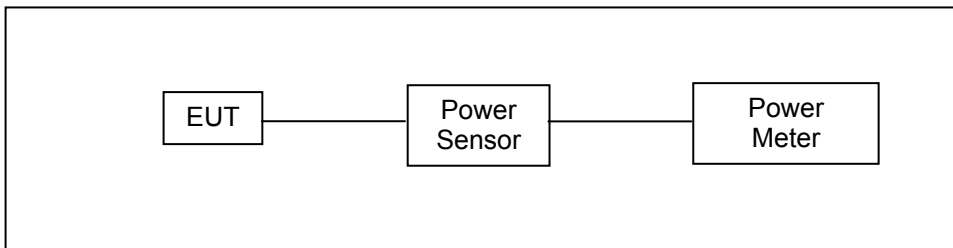

### 6.3. Test Instruments

Equipment	Manufacturer	Model Number	Serial Number	Cal. Date	Remark
Single Channel PK Power Sensor	Agilent	N1911A	MY45101619	07/19/2010	(1)
Wideband Power Meter	Agilent	N1921A	MY45241957	07/19/2010	(1)
Test Site	ATL	TE06	TE06	N.C.R.	----

Remark: (1) Calibration period 1 year. (2) Calibration period 2 years.

NOTE: N.C.R. = No Calibration Request.

### 6.4. Test Procedure

The tests below are run with the EUT's transmitter set at high power in TX mode. The EUT is needed to force selection of output power level and channel number. While testing, EUT was set to transmit continuously. Remove the Subjective device's antenna and connect the RF output port to power sensor. The maximum peak output power shall not exceed 1 watt.

Use a direct connection between the antenna port of transmitter and the power sensor, for prevent the power sensor input attenuation 40-50 dB. Set the RBW Bandwidth of the emission or use a channel power meter mode.

For antennas with gains of 6 dBi or less, maximum allowed transmitter output is 1 watt (+30 dBm). For antennas with gains greater than 6 dBi, transmitter output level must be decreased by an amount equal to (GAIN - 6)/3 dBm.

The antenna port of the EUT was connected to the input of a power sensor. Power was read directly and cable loss correction was added to the reading to obtain power at the EUT antenna terminals.

**6.5. Test Result**

Model Number	PC10110					
Test Item	Maximum Conducted Output Power					
Test Mode	Mode 3: GFSK Link Mode					
Date of Test	08/05/2010			Test Site	TE06	
Frequency (MHz)	Packet Type	Average Power		Peak Power		Limit (W)
		(dBm)	(W)	(dBm)	(W)	
2402	DH1	-5.54	0.00028	0.29	0.00107	< 1
	DH3	-2.22	0.00060	0.30	0.00107	< 1
	DH5	-2.67	0.00054	0.29	0.00107	< 1
2441	DH1	-5.36	0.00029	0.35	0.00108	< 1
	DH3	-2.04	0.00063	<b>0.46</b>	<b>0.00111</b>	< 1
	DH5	-2.48	0.00056	0.37	0.00109	< 1
2480	DH1	-5.55	0.00028	0.12	0.00103	< 1
	DH3	-2.22	0.00060	0.13	0.00103	< 1
	DH5	-2.67	0.00054	0.12	0.00103	< 1

Model Number	PC10110					
Test Item	Maximum Conducted Output Power					
Test Mode	Mode 4: $\pi/4$ -DQPSK Mode					
Date of Test	08/05/2010			Test Site	TE06	
Frequency (MHz)	Packet Type	Average Power		Peak Power		Limit (W)
		(dBm)	(W)	(dBm)	(W)	
2402	DH1	-5.41	0.00029	3.16	0.00207	< 1
	DH3	-3.45	0.00045	3.20	0.00209	< 1
	DH5	-5.22	0.00030	3.17	0.00207	< 1
2441	DH1	-5.20	0.00030	3.30	0.00214	< 1
	DH3	-3.27	0.00047	<b>3.31</b>	<b>0.00214</b>	< 1
	DH5	-5.02	0.00031	3.28	0.00213	< 1
2480	DH1	-5.39	0.00029	3.10	0.00204	< 1
	DH3	-3.44	0.00045	3.12	0.00205	< 1
	DH5	-5.20	0.00030	3.09	0.00204	< 1

Model Number	PC10110					
Test Item	Maximum Conducted Output Power					
Test Mode	Mode 5: 8DPSK Link Mode					
Date of Test	08/05/2010			Test Site	TE06	
Frequency (MHz)	Packet Type	Average Power		Peak Power		Limit (W)
		(dBm)	(W)	(dBm)	(W)	
2402	DH1	-8.06	0.00016	1.08	0.00128	< 1
	DH3	-7.61	0.00017	1.09	0.00129	< 1
	DH5	-9.36	0.00012	0.95	0.00124	< 1
2441	DH1	-7.90	0.00016	1.10	0.00129	< 1
	DH3	-7.46	0.00018	1.13	0.00130	< 1
	DH5	-9.19	0.00012	<b>1.22</b>	<b>0.00132</b>	< 1
2480	DH1	-8.13	0.00015	0.83	0.00121	< 1
	DH3	-7.70	0.00017	0.84	0.00121	< 1
	DH5	-9.43	0.00011	0.86	0.00122	< 1

## 7 Minimum 20dB RF Bandwidth Measurement

### 7.1. Limit

N/A

### 7.2. Test Setup

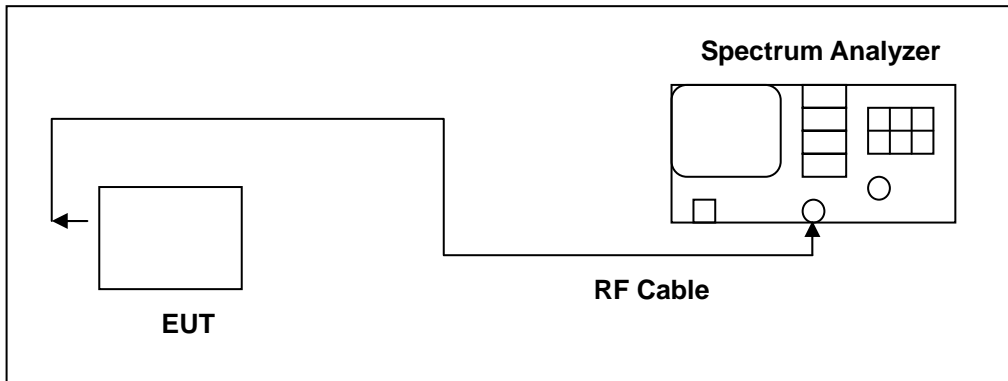

### 7.3. Test Instruments

Equipment	Manufacturer	Model Number	Serial Number	Cal. Date	Remark
Spectrum Analyzer	Agilent	E4445A	MY46181986	05/14/2009	(2)
Test Site	ATL	TE06	TE06	N.C.R.	-----

Remark: (1) Calibration period 1 year. (2) Calibration period 2 years.

NOTE: N.C.R. = No Calibration Request.

### 7.4. Test Procedure

The RF output port of the Equipment-Under-Test is directly coupled to the input of the EMC analyzer through a specialized RF connector and a 10dB passive attenuator. A fully charged battery was used for the supply voltage. The Bluetooth frequency hopping function of the EUT was enabled. The spectrum analyzer used the following settings:

1. Span = approx. 2 to 3 times the 20dB bandwidth, centered on a hopping frequency
2. RBW  $\geq$  1% of the 20dB span
3. VBW  $\geq$  RBW
4. Sweep = auto
5. Detector function = peak
6. Trace = max hold

The trace was allowed to stabilize. The EUT was transmitting at its maximum data rate. The marker-to-peak function was used to set the marker to the peak of the emission. The marker-delta function was used to measure 20dB down one side of the emission. The marker-delta function and marker was moved to the other side of the emission until it was even with the reference marker. The marker-delta reading at this point was the 20dB bandwidth of the emission.

## 7.5. Test Result

Model Number	PC10110		
Test Item	Minimum 20dB RF Bandwidth		
Test Mode	Mode 3: GFSK Link Mode		
Date of Test	08/03/2010	Test Site	TE06
Frequency (MHz)	Measurement (MHz)	Limit (MHz)	
2402	0.92625	-----	
2441	0.92625	-----	
2480	0.93000	-----	

Model Number	PC10110		
Test Item	Minimum 20dB RF Bandwidth		
Test Mode	Mode 4: $\pi/4$ -DQPSK Link Mode		
Date of Test	08/03/2010	Test Site	TE06
Frequency (MHz)	20dB Bandwidth (MHz)	Limit (MHz)	
2402	1.31250	-----	
2441	1.31250	-----	
2480	1.29375	-----	

**7.6. Test Graphs**

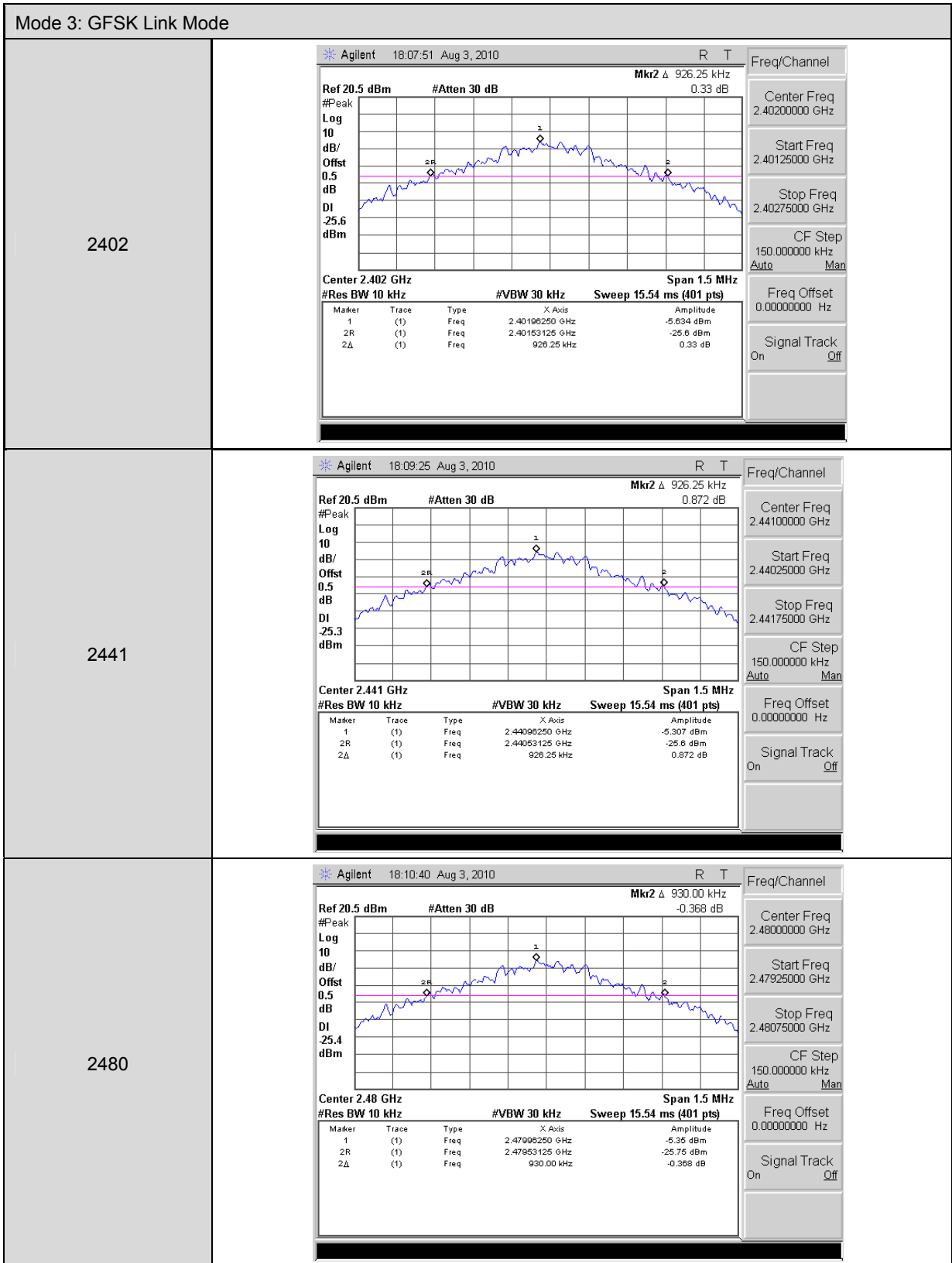

Mode 4: $\pi/4$ -DQPSK Link Mode																					
2402	<p>Agilent 18:15:05 Aug 3, 2010</p> <p>Ref 20.5 dBm #Atten 30 dB Mkr2 <math>\Delta</math> 1.31250 MHz 0.153 dB</p> <p>Center 2.402 GHz Span 1.5 MHz</p> <table border="1"> <thead> <tr> <th>Marker</th> <th>Trace</th> <th>Type</th> <th>X Axis</th> <th>Amplitude</th> </tr> </thead> <tbody> <tr> <td>1</td> <td>(1)</td> <td>Freq</td> <td>2.40215000 GHz</td> <td>-6.511 dBm</td> </tr> <tr> <td>2R</td> <td>(1)</td> <td>Freq</td> <td>2.40132875 GHz</td> <td>-26.54 dBm</td> </tr> <tr> <td>2<math>\Delta</math></td> <td>(1)</td> <td>Freq</td> <td>1.31250 MHz</td> <td>0.153 dB</td> </tr> </tbody> </table>	Marker	Trace	Type	X Axis	Amplitude	1	(1)	Freq	2.40215000 GHz	-6.511 dBm	2R	(1)	Freq	2.40132875 GHz	-26.54 dBm	2 $\Delta$	(1)	Freq	1.31250 MHz	0.153 dB
Marker	Trace	Type	X Axis	Amplitude																	
1	(1)	Freq	2.40215000 GHz	-6.511 dBm																	
2R	(1)	Freq	2.40132875 GHz	-26.54 dBm																	
2 $\Delta$	(1)	Freq	1.31250 MHz	0.153 dB																	
2441	<p>Agilent 18:13:42 Aug 3, 2010</p> <p>Ref 20.5 dBm #Atten 30 dB Mkr2 <math>\Delta</math> 1.31250 MHz -0.018 dB</p> <p>Center 2.441 GHz Span 1.5 MHz</p> <table border="1"> <thead> <tr> <th>Marker</th> <th>Trace</th> <th>Type</th> <th>X Axis</th> <th>Amplitude</th> </tr> </thead> <tbody> <tr> <td>1</td> <td>(1)</td> <td>Freq</td> <td>2.44115000 GHz</td> <td>-6.13 dBm</td> </tr> <tr> <td>2R</td> <td>(1)</td> <td>Freq</td> <td>2.44032875 GHz</td> <td>-26.02 dBm</td> </tr> <tr> <td>2<math>\Delta</math></td> <td>(1)</td> <td>Freq</td> <td>1.31250 MHz</td> <td>-0.018 dB</td> </tr> </tbody> </table>	Marker	Trace	Type	X Axis	Amplitude	1	(1)	Freq	2.44115000 GHz	-6.13 dBm	2R	(1)	Freq	2.44032875 GHz	-26.02 dBm	2 $\Delta$	(1)	Freq	1.31250 MHz	-0.018 dB
Marker	Trace	Type	X Axis	Amplitude																	
1	(1)	Freq	2.44115000 GHz	-6.13 dBm																	
2R	(1)	Freq	2.44032875 GHz	-26.02 dBm																	
2 $\Delta$	(1)	Freq	1.31250 MHz	-0.018 dB																	
2480	<p>Agilent 18:12:44 Aug 3, 2010</p> <p>Ref 20.5 dBm #Atten 30 dB Mkr2 <math>\Delta</math> 1.29375 MHz 0.58 dB</p> <p>Center 2.48 GHz Span 1.5 MHz</p> <table border="1"> <thead> <tr> <th>Marker</th> <th>Trace</th> <th>Type</th> <th>X Axis</th> <th>Amplitude</th> </tr> </thead> <tbody> <tr> <td>1</td> <td>(1)</td> <td>Freq</td> <td>2.48015000 GHz</td> <td>-6.141 dBm</td> </tr> <tr> <td>2R</td> <td>(1)</td> <td>Freq</td> <td>2.47934750 GHz</td> <td>-26.17 dBm</td> </tr> <tr> <td>2<math>\Delta</math></td> <td>(1)</td> <td>Freq</td> <td>1.29375 MHz</td> <td>0.58 dB</td> </tr> </tbody> </table>	Marker	Trace	Type	X Axis	Amplitude	1	(1)	Freq	2.48015000 GHz	-6.141 dBm	2R	(1)	Freq	2.47934750 GHz	-26.17 dBm	2 $\Delta$	(1)	Freq	1.29375 MHz	0.58 dB
Marker	Trace	Type	X Axis	Amplitude																	
1	(1)	Freq	2.48015000 GHz	-6.141 dBm																	
2R	(1)	Freq	2.47934750 GHz	-26.17 dBm																	
2 $\Delta$	(1)	Freq	1.29375 MHz	0.58 dB																	

## 8 Carrier Frequency Separation Measurement

### 8.1. Limit

Title 47 of the CFR: 2002, Part 15 Subpart (c) 15.247(a)(1)(i) requires the measurement of the bandwidth of the transmission between the -20 dB points on the transmitted spectrum. The results of this test determine the limits for channel spacing. The channel spacing shall be a minimum of 25 kHz or the 20 dB bandwidth.

### 8.2. Test Setup

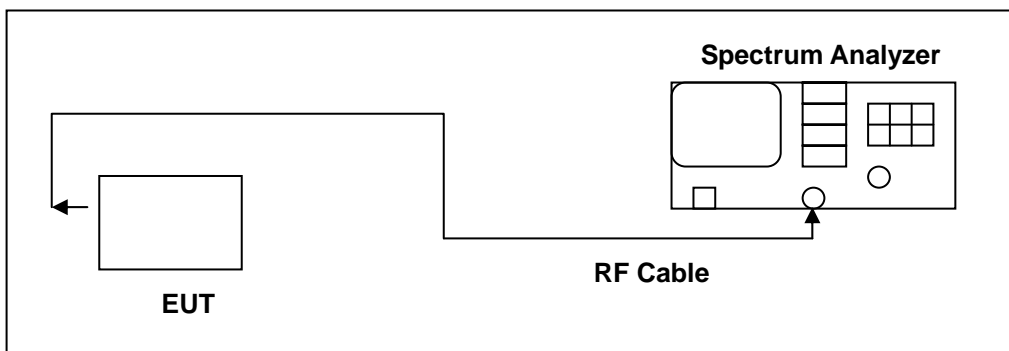

### 8.3. Test Instruments

Equipment	Manufacturer	Model Number	Serial Number	Cal. Date	Remark
Spectrum Analyzer	Agilent	E4445A	MY46181986	05/14/2009	(2)
Test Site	ATL	TE06	TE06	N.C.R.	-----

Remark: (1) Calibration period 1 year. (2) Calibration period 2 years.

NOTE: N.C.R. = No Calibration Request.



#### 8.4. Test Procedure

The RF output port of the Equipment-Under-Test is directly coupled to the input of the EMC analyzer through a specialized RF connector and a 10dB passive attenuator. A fully charged battery was used for the supply voltage. The Bluetooth transmitter of the V6 had its hopping function enabled. The following spectrum analyzer settings were used:

1. Span = wide enough to capture the peaks of two adjacent channels
2. Resolution (or IF) Bandwidth (RBW)  $\geq$  1% of the span
3. Video (or Average) Bandwidth (VBW)  $\geq$  RBW
4. Sweep = auto
5. Detector function = peak
6. Trace = max hold

The trace was allowed to stabilize. The marker-delta function was used to determine the separation between the peaks of the adjacent channels.

### 8.5. Test Result

Model Number	PC10110		
Test Item	Carrier Frequency Separation		
Test Mode	Mode 3: GFSK Link Mode		
Date of Test	08/03/2010	Test Site	TE06
Frequency (MHz)	Measurement (MHz)	Limit (MHz)	
2441	1	minimum of 25 kHz or the 20 dB bandwidth	

Model Number	PC10110		
Test Item	Carrier Frequency Separation		
Test Mode	Mode 4: $\pi/4$ -DQPSK Link Mode		
Date of Test	08/03/2010	Test Site	TE06
Frequency (MHz)	Measurement (MHz)	Limit (MHz)	
2441	1	minimum of 25 kHz or the 20 dB bandwidth	

**8.6. Test Graphs**

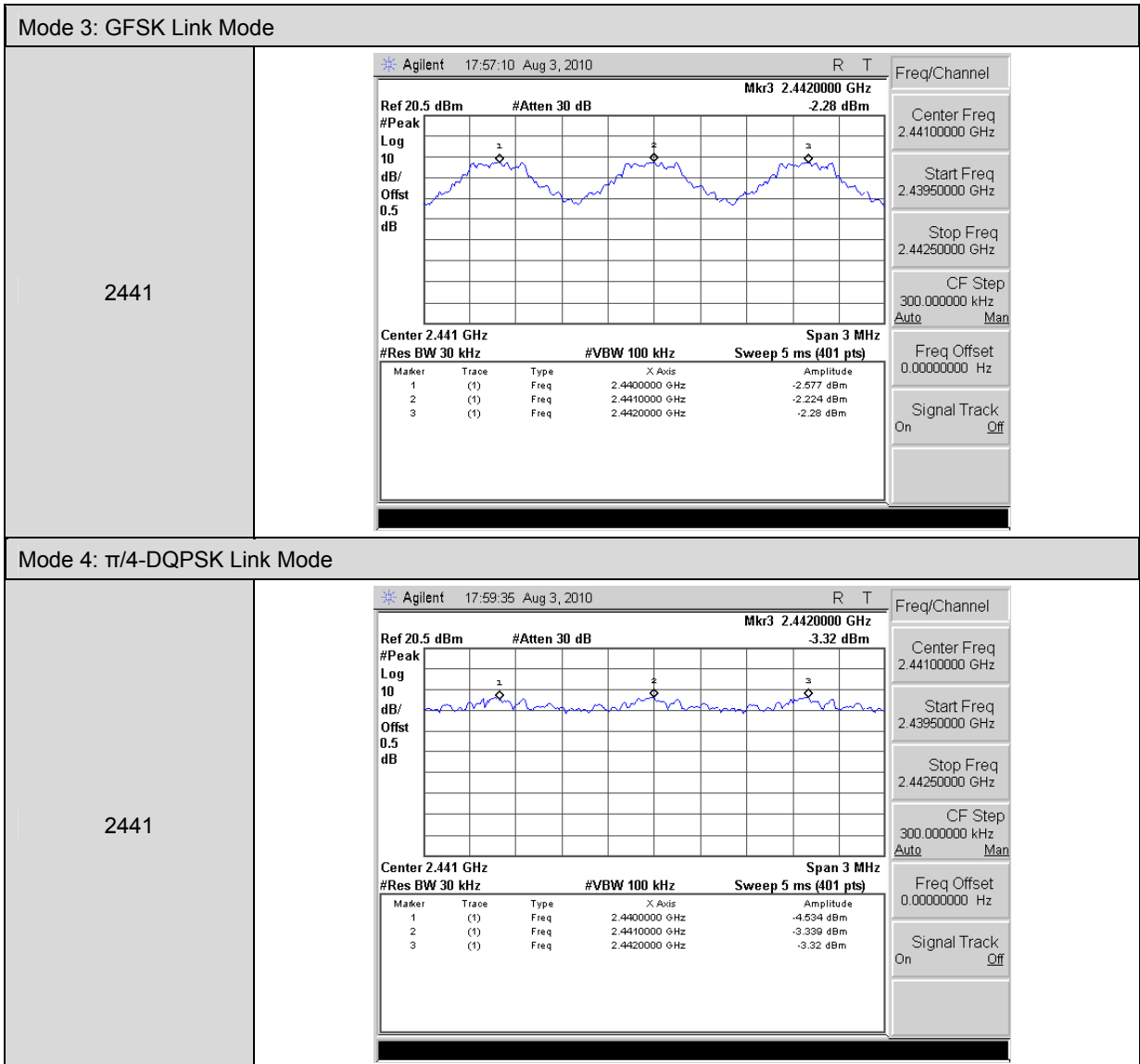

## 9 Number of Hopping Measurement

### 9.1. Limit

Frequency hopping systems in the 2400–2483.5 MHz band shall use at least 15 channels.

### 9.2. Test Setup

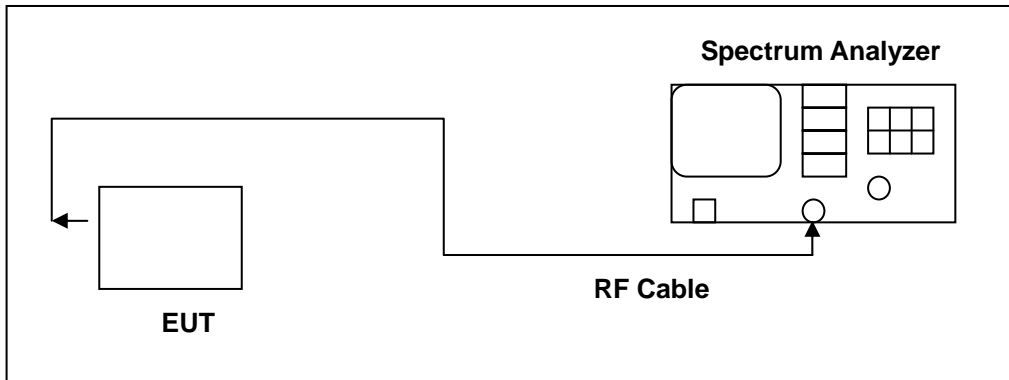

### 9.3. Test Instruments

Equipment	Manufacturer	Model Number	Serial Number	Cal. Date	Remark
Spectrum Analyzer	Agilent	E4445A	MY46181986	05/14/2009	(2)
Test Site	ATL	TE06	TE06	N.C.R.	-----

Remark: (1) Calibration period 1 year. (2) Calibration period 2 years.

NOTE: N.C.R. = No Calibration Request.

### 9.4. Test Procedure

The RF output port of the Equipment-Under-Test is directly coupled to the input of the EMC analyzer through a specialized RF connector and a 10dB passive attenuator. A fully charged battery was used for the supply voltage. The Bluetooth frequency hopping function of the EUT was enabled. The spectrum analyzer used the following settings:

1. Span = the frequency band of operation
2. RBW  $\geq$  1% of the span
3. VBW  $\geq$  RBW
4. Sweep = auto
5. Detector function = peak
6. Trace = max hold

The trace was allowed to stabilize.

**9.5. Test Result**

Model Number	PC10110		
Test Item	Number of Hopping		
Test Mode	Mode 3: GFSK Link Mode		
Date of Test	08/05/2010	Test Site	TE06
Frequency Range (MHz)	Measurement (ch)		Limit (ch)
2402 - 2480	79		> 15

Model Number	PC10110		
Test Item	Number of Hopping		
Test Mode	Mode 4: $\pi/4$ -DQPSK Link Mode		
Date of Test	08/05/2010	Test Site	TE06
Frequency Range (MHz)	Measurement (ch)		Limit (ch)
2402 - 2480	79		> 15

**9.6. Test Graphs**

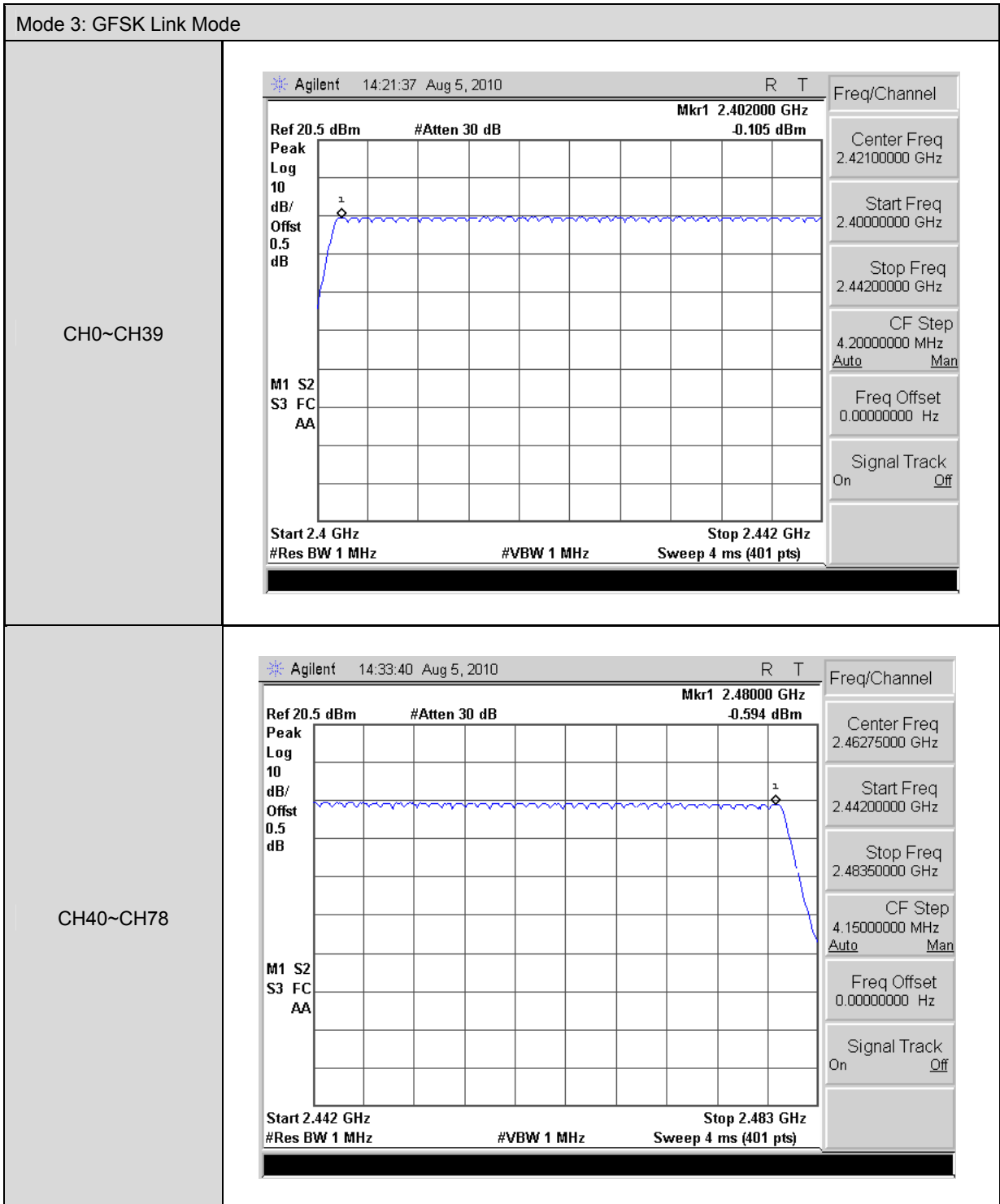

Mode 4:  $\pi/4$ -DQPSK Link Mode

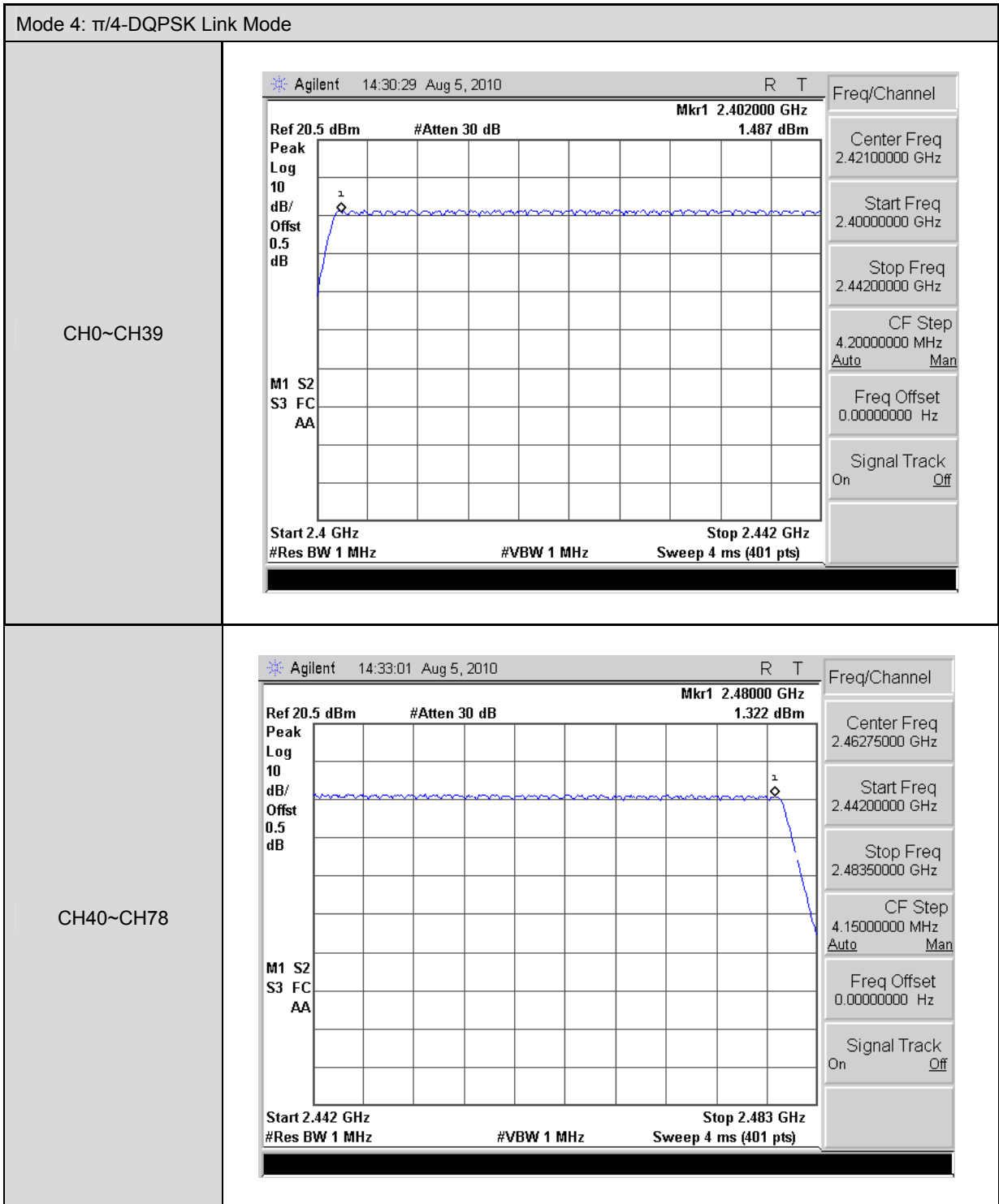

## 10 Time of Occupancy (Dwell Time) Measurement

### 10.1.Limit

The average time of occupancy on any channel shall not be greater than 0.4 seconds within a period of 0.4 seconds multiplied by the number of hopping channels employed.

### 10.2.Test Setup

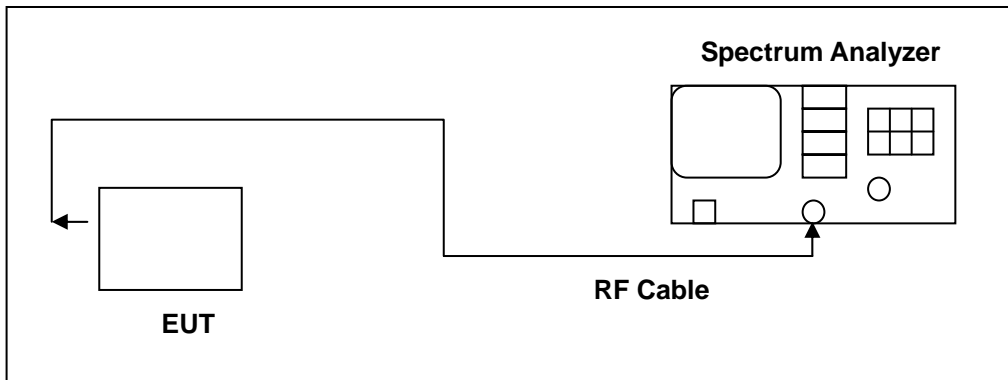

### 10.3.Test Instruments

Equipment	Manufacturer	Model Number	Serial Number	Cal. Date	Remark
Spectrum Analyzer	Agilent	E4445A	MY46181986	05/14/2009	(2)
Test Site	ATL	TE06	TE06	N.C.R.	-----

Remark: (1) Calibration period 1 year. (2) Calibration period 2 years.

NOTE: N.C.R. = No Calibration Request.

### 10.4.Test Procedure

The RF output port of the Equipment-Under-Test is directly coupled to the input of the EMC analyzer through a specialized RF connector and a 10dB passive attenuator. A fully charged battery was used for the supply voltage. The Bluetooth hopping function of the EUT was enabled. The following spectrum analyzer settings were used:

1. Span = zero span, centered on a hopping channel
2. RBW = 1 MHz
3. VBW  $\geq$  RBW
4. Sweep = as necessary to capture the entire dwell time per hopping channel
5. Detector function = peak
6. Trace = max hold

The marker-delta function was used to determine the dwell time.



**10.5.Test Result**

Model Number	PC10110		
Test Item	Time of Occupancy (Dwell Time)		
Test Mode	Mode 3: GFSK Link Mode		
Date of Test	08/03/2010	Test Site	TE06
DH1			
Cycle Calculate	79CH * 0.4 = 31.6 (sec)		
The EUT Hopping Number per Sec	1600 times/sec		
Each Channel Dwell Times per Sec	800/79CH = 10.13(times/sec)		
Each Channel Dwell Times (1)	0.525	ms (sec)	
Each Channel Dwell Times on Cycle(2)	31.6 * 10.13 = 320.108(times)		
Dwell Times on Cycle (1) * (2)	168.0567	ms (sec)	
LIMIT(msec)	< = 400		
DH3			
Cycle Calculate	79CH * 0.4 = 31.6 (sec)		
The EUT Hopping Number per Sec	1600 times/sec		
Each Channel Dwell Times per Sec	400/79CH = 5.1(times/sec)		
Each Channel Dwell Times (1)	1.775	ms (sec)	
Each Channel Dwell Times on Cycle(2)	31.6 * 5.1 = 161.16(times)		
Dwell Times on Cycle (1) * (2)	286.0590	ms (sec)	
LIMIT(msec)	< = 400		
DH5			
Cycle Calculate	79CH * 0.4 = 31.6 (sec)		
The EUT Hopping Number per Sec	1600 times/sec		
Each Channel Dwell Times per Sec	266.7/79CH = 3.37(times/sec)		
Each Channel Dwell Times (1)	2.375	ms (sec)	
Each Channel Dwell Times on Cycle(2)	31.6 * 3.37 = 106.492(times)		
Dwell Times on Cycle (1) * (2)	252.9185	ms (sec)	
LIMIT(msec)	< = 400		

Model Number	PC10110		
Test Item	Time of Occupancy (Dwell Time)		
Test Mode	Mode 4: $\pi/4$ -DQPSK Link Mode		
Date of Test	08/03/2010	Test Site	TE06
2DH1			
Cycle Calculate	$79CH * 0.4 = 31.6$ (sec)		
The EUT Hopping Number per Sec	1600 times/sec		
Each Channel Dwell Times per Sec	$800/79CH = 10.13$ (times/sec)		
Each Channel Dwell Times (1)	0.525	ms (sec)	
Each Channel Dwell Times on Cycle(2)	$31.6 * 10.13 = 320.108$ (times)		
Dwell Times on Cycle (1) * (2)	168.0567	ms (sec)	
LIMIT(msec)	< = 400		
2DH3			
Cycle Calculate	$79CH * 0.4 = 31.6$ (sec)		
The EUT Hopping Number per Sec	1600 times/sec		
Each Channel Dwell Times per Sec	$400/79CH = 5.1$ (times/sec)		
Each Channel Dwell Times (1)	1.350	ms (sec)	
Each Channel Dwell Times on Cycle(2)	$31.6 * 5.1 = 161.16$ (times)		
Dwell Times on Cycle (1) * (2)	217.566	ms (sec)	
LIMIT(msec)	< = 400		
2DH5			
Cycle Calculate	$79CH * 0.4 = 31.6$ (sec)		
The EUT Hopping Number per Sec	1600 times/sec		
Each Channel Dwell Times per Sec	$266.7/79CH = 3.37$ (times/sec)		
Each Channel Dwell Times (1)	1.375	ms (sec)	
Each Channel Dwell Times on Cycle(2)	$31.6 * 3.37 = 106.492$ (times)		
Dwell Times on Cycle (1) * (2)	146.4265	ms (sec)	
LIMIT(msec)	< = 400		

**10.6. Test Graphs**

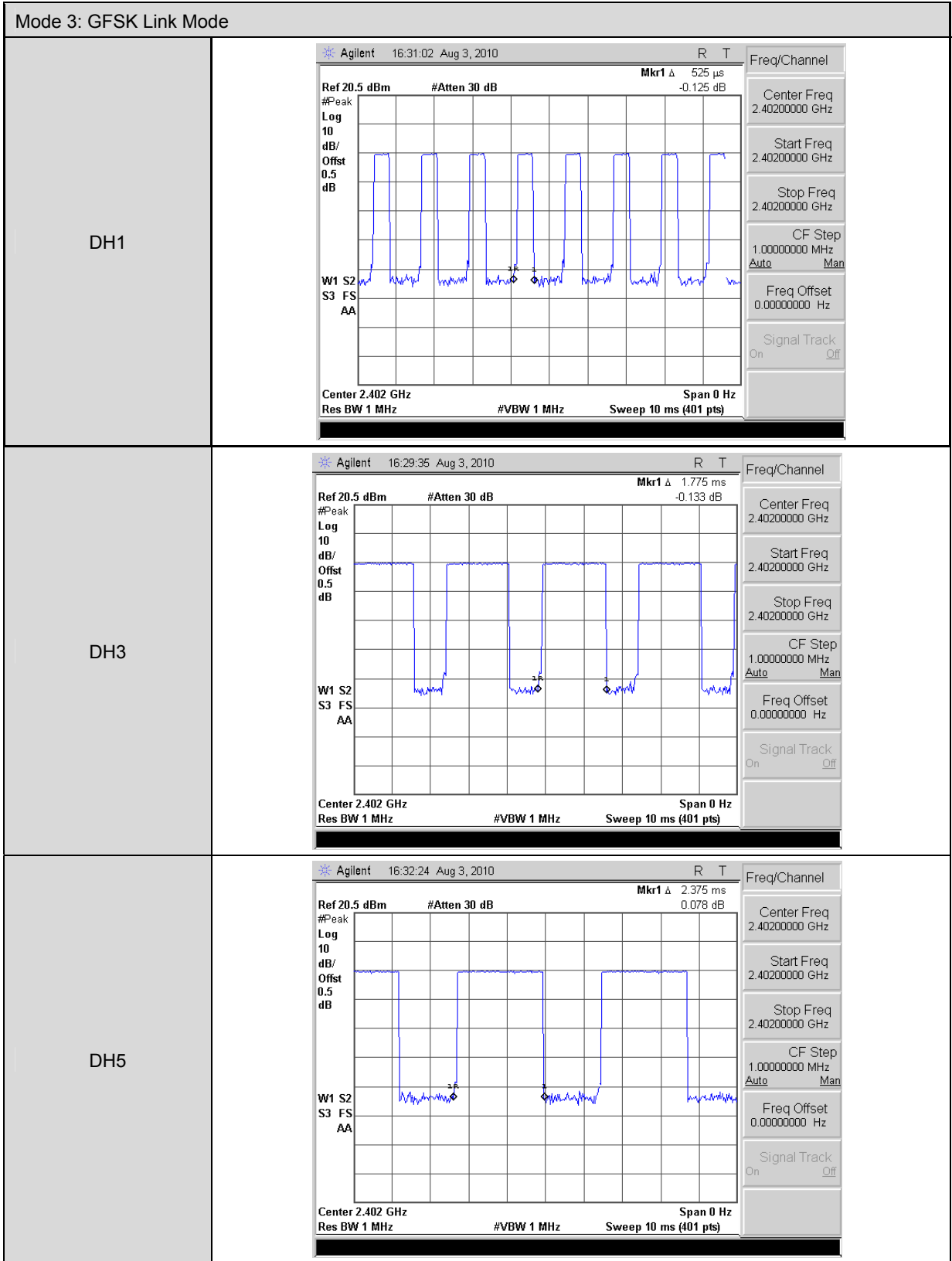

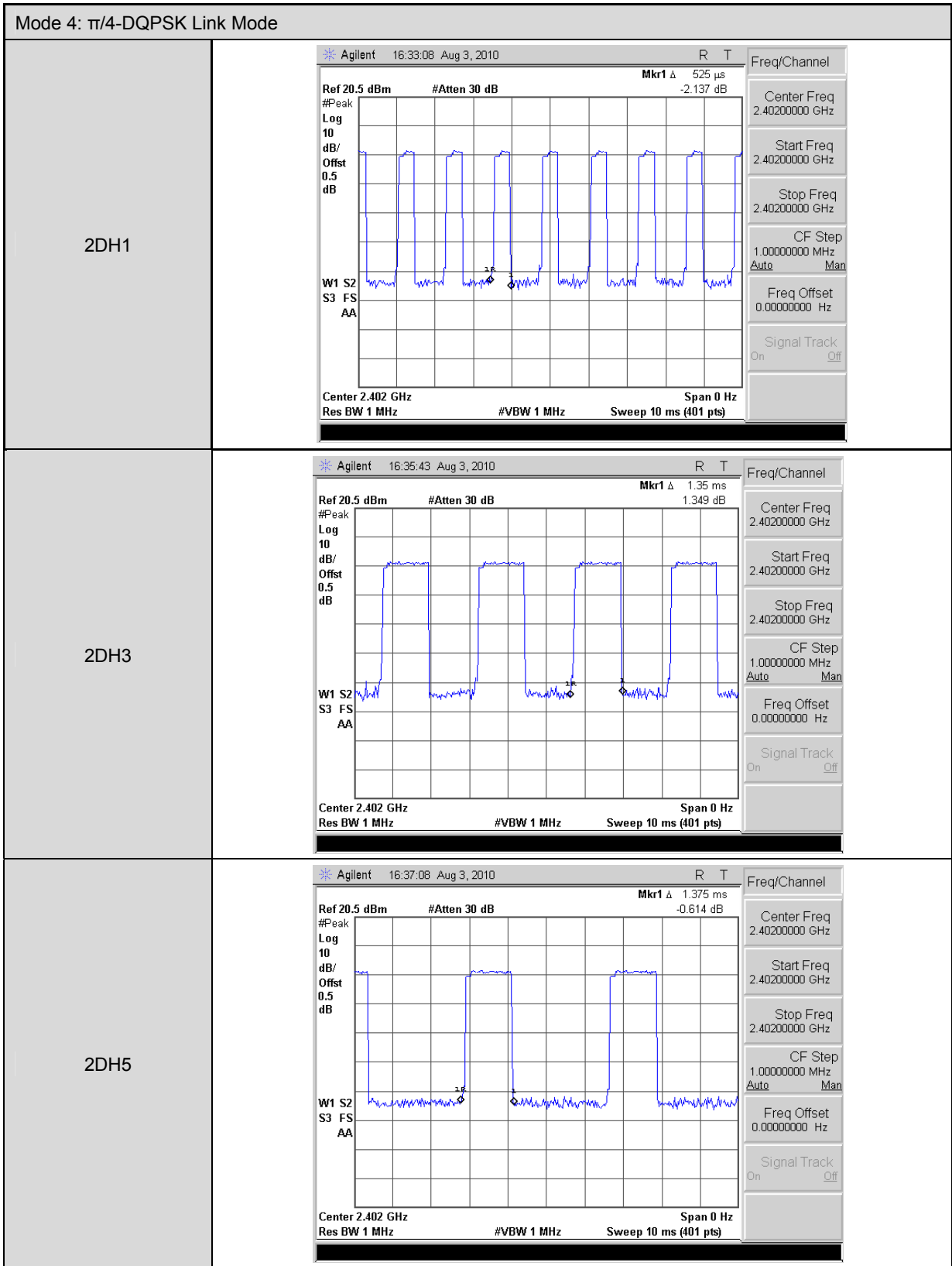

## 11 Out of Band Conducted Emissions Measurement

### 11.1.Limit

In any 100 kHz bandwidth outside the frequency band in which the spread spectrum or digitally modulated intentional radiator is operating, the radio frequency power that is produced by the intentional radiator shall be at least 20 dB below that in the 100 kHz bandwidth within the band that contains the highest level of the desired power

### 11.2.Test Setup

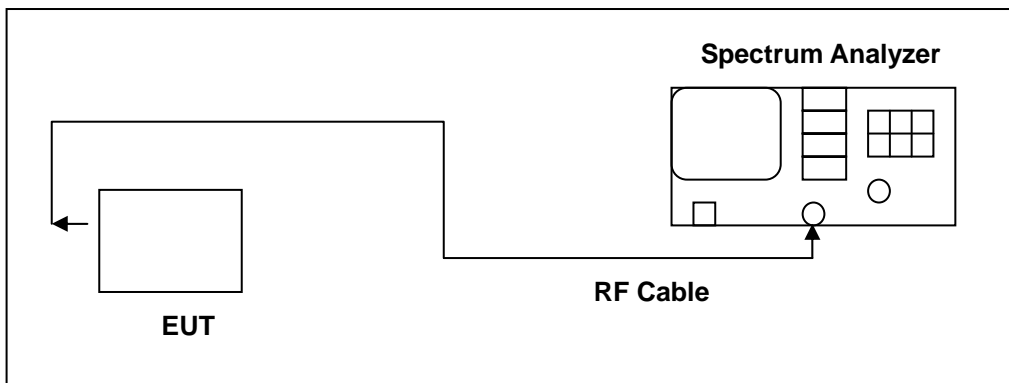

### 11.3.Test Instruments

Equipment	Manufacturer	Model Number	Serial Number	Cal. Date	Remark
Spectrum Analyzer	Agilent	E4445A	MY46181986	05/14/2009	(2)
Test Site	ATL	TE06	TE06	N.C.R.	-----

Remark: (1) Calibration period 1 year. (2) Calibration period 2 years.

NOTE: N.C.R. = No Calibration Request.

### 11.4.Test Procedure

In any 100 kHz bandwidth outside the EUT pass band, the RF power produced by the modulation products of the spreading sequence, the information sequence, and the carrier frequency shall be at least 20 dB below that of the maximum in-band 100 kHz emission, antenna output of the EUT was coupled directly to spectrum analyzer; if an external attenuator and/or cable was used, these losses are compensated for with the analyzer OFFSET function.

All other types of emissions from the EUT shall meet the general limits for radiated frequencies outside the pass band. The test was performed at 3 channels (Channel 0, 39, 78)

**11.5. Test Graphs**

Mode 3: GFSK Link Mode	
2402	<p>Agilent 15:01:36 Aug 5, 2010 R T</p> <p>Ref 20.5 dBm #Atten 30 dB Mkr1 2.40 GHz -1.957 dBm</p> <p>Peak Log 10 dB/Offst 0.5 dB DI -22.0 dBm V1 S2 S3 FC AA</p> <p>Start 30 MHz Stop 26.5 GHz #Res BW 100 kHz #VBW 100 kHz Sweep 3.41 s (401 pts)</p> <p>Freq/Channel: Center Freq 13.2650000 GHz, Start Freq 30.0000000 MHz, Stop Freq 26.5000000 GHz, CF Step 2.64700000 GHz, Freq Offset 0.00000000 Hz, Signal Track Off</p>
2441	<p>Agilent 15:00:42 Aug 5, 2010 R T</p> <p>Ref 20.5 dBm #Atten 30 dB Mkr1 2.44 GHz -1.477 dBm</p> <p>Peak Log 10 dB/Offst 0.5 dB DI -21.5 dBm V1 S2 S3 FC AA</p> <p>Start 30 MHz Stop 26.5 GHz #Res BW 100 kHz #VBW 100 kHz Sweep 3.41 s (401 pts)</p> <p>Freq/Channel: Center Freq 13.2650000 GHz, Start Freq 30.0000000 MHz, Stop Freq 26.5000000 GHz, CF Step 2.64700000 GHz, Freq Offset 0.00000000 Hz, Signal Track Off</p>
2480	<p>Agilent 14:58:15 Aug 5, 2010 R T</p> <p>Ref 20.5 dBm #Atten 30 dB Mkr1 2.48 GHz -2.199 dBm</p> <p>Peak Log 10 dB/Offst 0.5 dB DI -22.2 dBm V1 S2 S3 FC AA</p> <p>Start 30 MHz Stop 26.5 GHz #Res BW 100 kHz #VBW 100 kHz Sweep 3.41 s (401 pts)</p> <p>Freq/Channel: Center Freq 13.2650000 GHz, Start Freq 30.0000000 MHz, Stop Freq 26.5000000 GHz, CF Step 2.64700000 GHz, Freq Offset 0.00000000 Hz, Signal Track Off</p>

Mode 4: $\pi/4$ -DQPSK Link Mode	
2402	<p>Agilent 14:53:12 Aug 5, 2010 R T</p> <p>Ref 20.5 dBm #Atten 30 dB Mkr1 2.40 GHz -1.627 dBm</p> <p>Peak Log 10 dB/Offst 0.5 dB DI -21.6 dBm</p> <p>V1 S2 S3 FC AA</p> <p>Start 30 MHz Stop 26.5 GHz #Res BW 100 kHz #VBW 100 kHz Sweep 3.41 s (401 pts)</p> <p>Freq/Channel: Center Freq 13.2650000 GHz, Start Freq 30.0000000 MHz, Stop Freq 26.5000000 GHz, CF Step 2.64700000 GHz, Freq Offset 0.00000000 Hz, Signal Track Off</p>
2441	<p>Agilent 14:54:32 Aug 5, 2010 R T</p> <p>Ref 20.5 dBm #Atten 30 dB Mkr1 2.44 GHz -3.809 dBm</p> <p>Peak Log 10 dB/Offst 0.5 dB DI -23.8 dBm</p> <p>V1 S2 S3 FC AA</p> <p>Start 30 MHz Stop 26.5 GHz #Res BW 100 kHz #VBW 100 kHz Sweep 3.41 s (401 pts)</p> <p>Freq/Channel: Center Freq 13.2650000 GHz, Start Freq 30.0000000 MHz, Stop Freq 26.5000000 GHz, CF Step 2.64700000 GHz, Freq Offset 0.00000000 Hz, Signal Track Off</p>
2480	<p>Agilent 14:55:38 Aug 5, 2010 R T</p> <p>Ref 20.5 dBm #Atten 30 dB Mkr1 2.48 GHz -3.609 dBm</p> <p>Peak Log 10 dB/Offst 0.5 dB DI -23.6 dBm</p> <p>V1 S2 S3 FC AA</p> <p>Start 30 MHz Stop 26.5 GHz #Res BW 100 kHz #VBW 100 kHz Sweep 3.41 s (401 pts)</p> <p>Freq/Channel: Center Freq 13.2650000 GHz, Start Freq 30.0000000 MHz, Stop Freq 26.5000000 GHz, CF Step 2.64700000 GHz, Freq Offset 0.00000000 Hz, Signal Track Off</p>

## 12 Band Edges Measurement

### 12.1.Limit

In any 100 kHz bandwidth outside the frequency band in which the spread spectrum or digitally modulated intentional radiator is operating, the radio frequency power that is produced by the intentional radiator shall be at least 20 dB below that in the 100 kHz bandwidth within the band that contains the highest level of the desired power

### 12.2.Test Setup

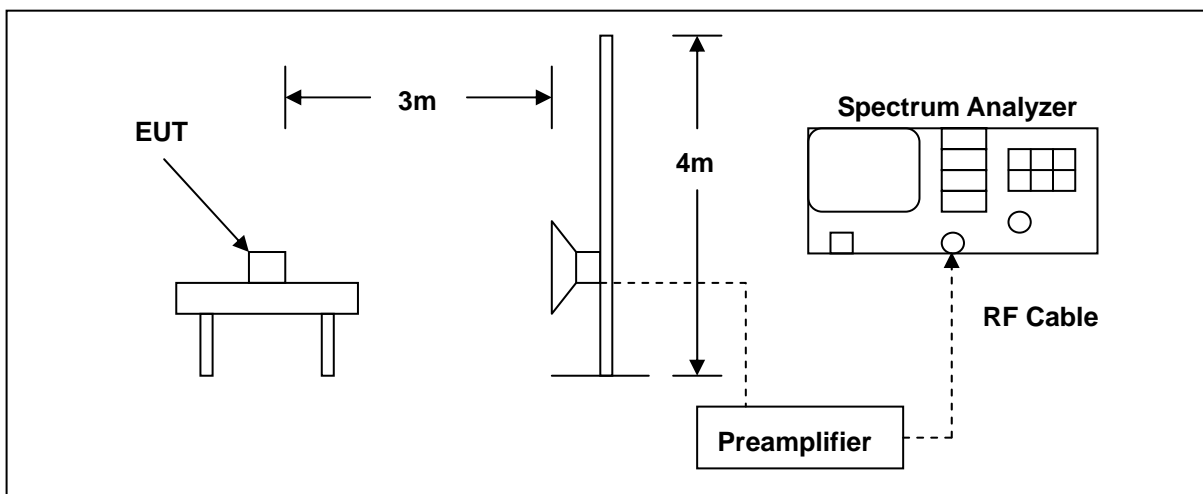

### 12.3.Test Instruments

Equipment	Manufacturer	Model Number	Serial Number	Cal. Date	Remark
Spectrum Analyzer	Agilent	E4408B	MY45107753	06/24/2010	(1)
Pre Amplifier	Agilent	8449B	3008A02237	02/24/2010	(1)
Horn Antenna	SCHWARZBECK MESS-ELEKTRONIK	9120D	9120D-550	06/29/2010	(1)
Test Site	ATL	TE06	TE06	N.C.R.	-----

Remark: (1) Calibration period 1 year. (2) Calibration period 2 years.

NOTE: N.C.R. = No Calibration Request.



## 12.4. Test Procedure

The emissions on the harmonics frequencies, the limits, and the margin of compliance are presented. These tests were made when the transmitter was in full radiated power. The additional test was performed to show compliance with the requirement at the band-edge frequency 2483.5 MHz and up to 2500 MHz and at 2390.0 MHz.

The transmitter was configured with the worst case antenna and setup to transmit at the highest channel. Then the field strength was measured at 2483.5 MHz.

The transmitter was then configured with the worst case antenna and setup to transmit at the lowest channel. Then the field strength was measured at 2390.0 MHz. These tests were performed at 4 different bit rates.

For measurements the resolution bandwidth is set to 1 MHz, and then the video bandwidth is set to 1 MHz for peak measurements and 10 Hz for average measurements.

**12.5.Test Result**

Standard:	FCC Part 15C	Test Distance:	3m
Test item:	Radiated Emission	Power:	AC 120V/60Hz
Model Number:	PC10110	Temp.(°C)/Hum.(%RH):	26(°C)/60%RH
Mode:	Mode 3	Date:	2010/08/12
Frequency:	2402 MHz	Test By:	Gary Wu
Ant.Polar.:	Horizontal		

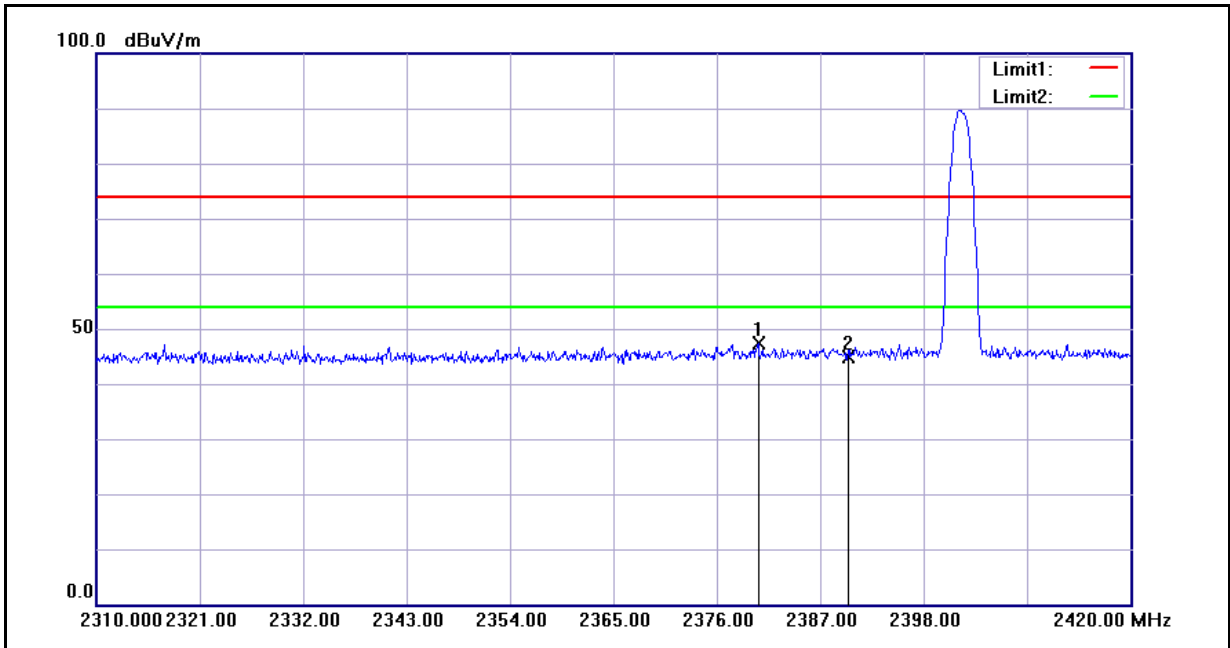

No.	Frequency (MHz)	Reading (dBuV)	Correct Factor(dB/m)	Result (dBuV/m)	Limit (dBuV/m)	Margin (dB)	Remark
1	2380.400	47.62	-0.26	47.36	74.00	-26.64	peak
2	2390.000	45.21	-0.22	44.99	74.00	-29.01	peak

Standard:	FCC Part 15C	Test Distance:	3m
Test item:	Radiated Emission	Power:	AC 120V/60Hz
Model Number:	PC10110	Temp.(°C)/Hum.(%RH):	26(°C)/60%RH
Mode:	Mode 3	Date:	2010/08/12
Frequency:	2402 MHz	Test By:	Gary Wu
Ant.Polar.:	Vertical		

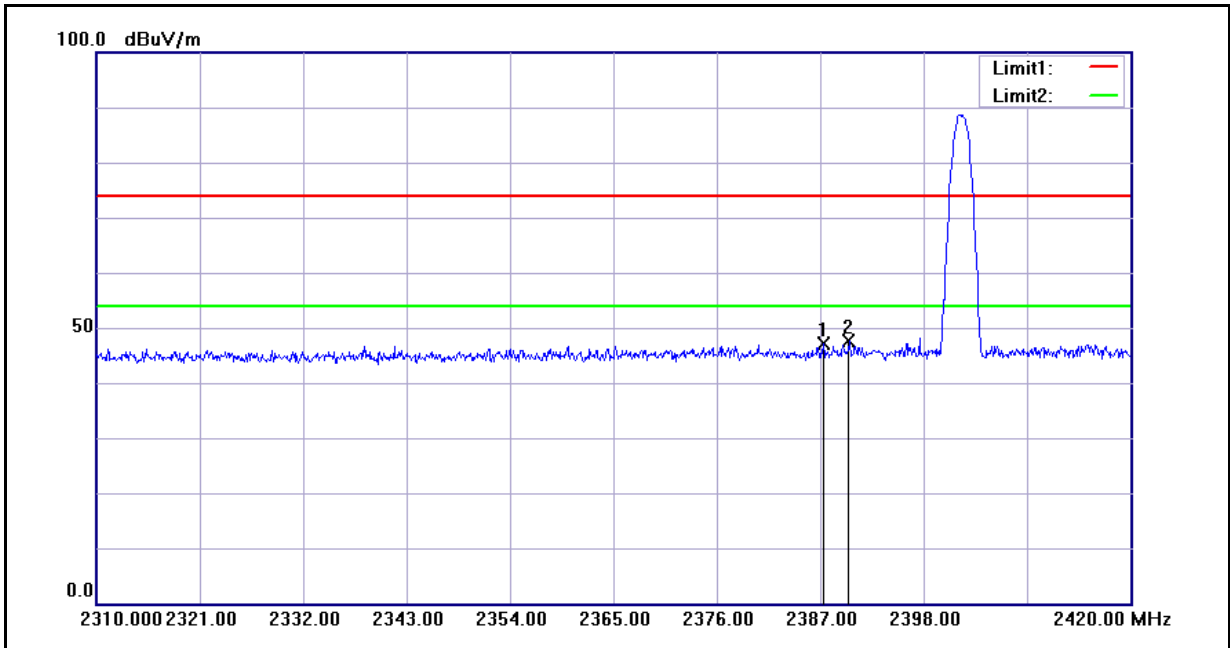

No.	Frequency (MHz)	Reading (dBuV)	Correct Factor(dB/m)	Result (dBuV/m)	Limit (dBuV/m)	Margin (dB)	Remark
1	2387.330	47.24	-0.22	47.02	74.00	-26.98	peak
2	2390.000	47.76	-0.22	47.54	74.00	-26.46	peak

Standard:	FCC Part 15C	Test Distance:	3m
Test item:	Radiated Emission	Power:	AC 120V/60Hz
Model Number:	PC10110	Temp.(°C)/Hum.(%RH):	26(°C)/60%RH
Mode:	Mode 3	Date:	2010/08/12
Frequency:	2480 MHz	Test By:	Gary Wu
Ant.Polar.:	Horizontal		

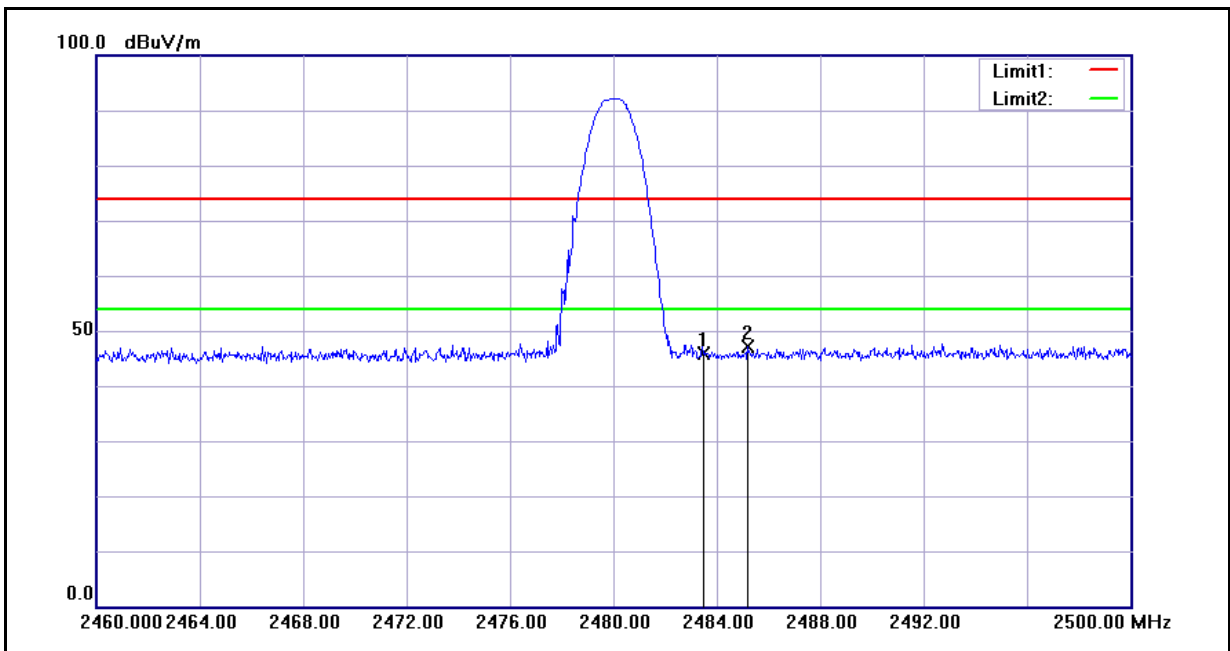

No.	Frequency (MHz)	Reading (dBuV)	Correct Factor(dB/m)	Result (dBuV/m)	Limit (dBuV/m)	Margin (dB)	Remark
1	2483.500	45.62	0.16	45.78	74.00	-28.22	peak
2	2485.200	46.92	0.16	47.08	74.00	-26.92	peak

Standard:	FCC Part 15C	Test Distance:	3m
Test item:	Radiated Emission	Power:	AC 120V/60Hz
Model Number:	PC10110	Temp.(°C)/Hum.(%RH):	26(°C)/60%RH
Mode:	Mode 3	Date:	2010/08/12
Frequency:	2480 MHz	Test By:	Gary Wu
Ant.Polar.:	Vertical		

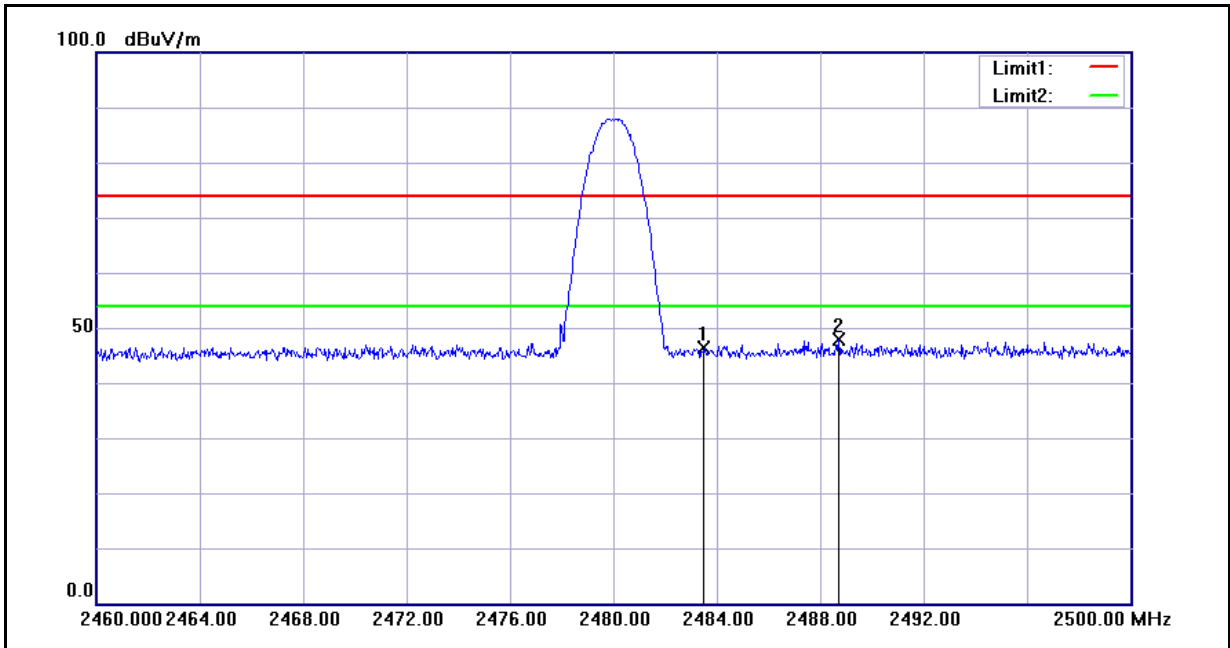

No.	Frequency (MHz)	Reading (dBuV)	Correct Factor(dB/m)	Result (dBuV/m)	Limit (dBuV/m)	Margin (dB)	Remark
1	2483.500	46.13	0.16	46.29	74.00	-27.71	peak
2	2488.720	47.69	0.18	47.87	74.00	-26.13	peak

Standard:	FCC Part 15C	Test Distance:	3m
Test item:	Radiated Emission	Power:	AC 120V/60Hz
Model Number:	PC10110	Temp.(°C)/Hum.(%RH):	26(°C)/60%RH
Mode:	Mode 4	Date:	2010/08/12
Frequency:	2402 MHz	Test By:	Gary Wu
Ant.Polar.:	Horizontal		

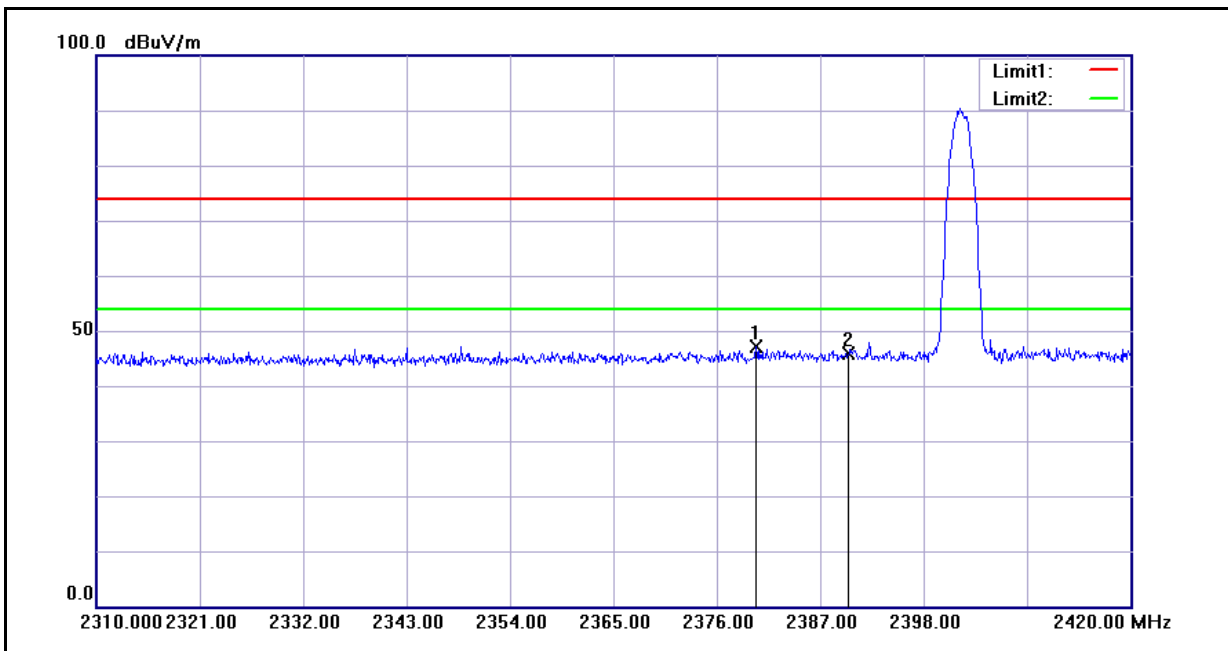

No.	Frequency (MHz)	Reading (dBuV)	Correct Factor(dB/m)	Result (dBuV/m)	Limit (dBuV/m)	Margin (dB)	Remark
1	2380.180	47.38	-0.26	47.12	74.00	-26.88	peak
2	2390.000	46.22	-0.22	46.00	74.00	-28.00	peak

Standard:	FCC Part 15C	Test Distance:	3m
Test item:	Radiated Emission	Power:	AC 120V/60Hz
Model Number:	PC10110	Temp.(°C)/Hum.(%RH):	26(°C)/60%RH
Mode:	Mode 4	Date:	2010/08/12
Frequency:	2402 MHz	Test By:	Gary Wu
Ant.Polar.:	Vertical		

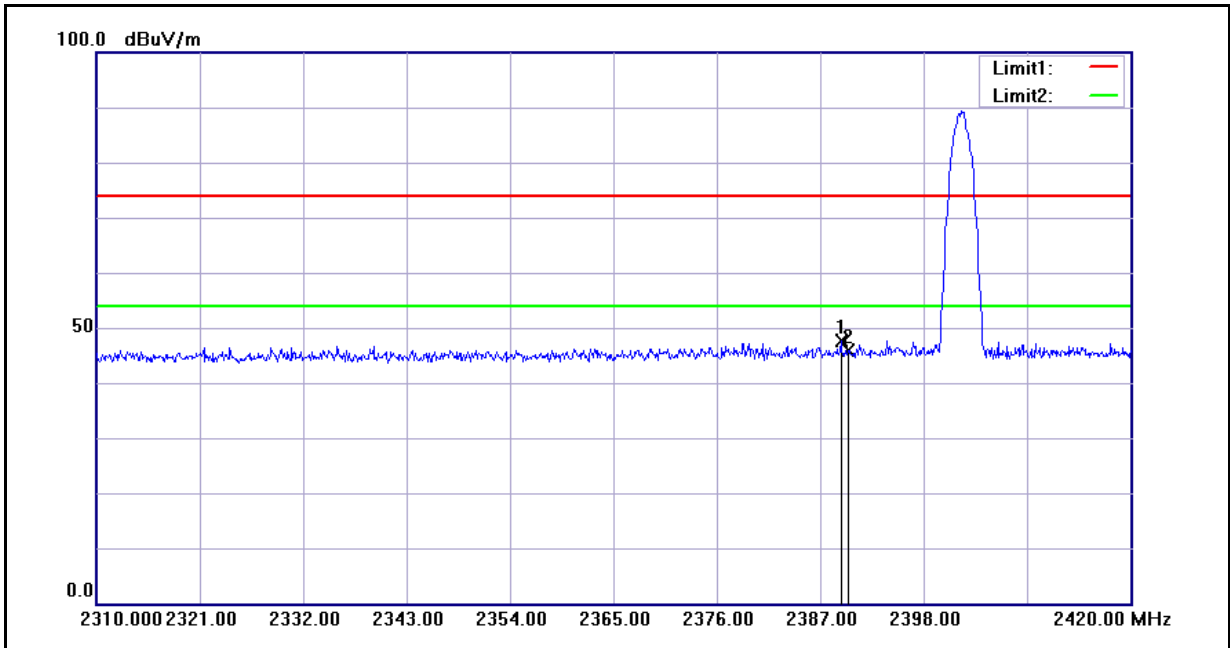

No.	Frequency (MHz)	Reading (dBuV)	Correct Factor(dB/m)	Result (dBuV/m)	Limit (dBuV/m)	Margin (dB)	Remark
1	2389.200	47.74	-0.22	47.52	74.00	-26.48	peak
2	2390.000	46.16	-0.22	45.94	74.00	-28.06	peak

Standard:	FCC Part 15C	Test Distance:	3m
Test item:	Radiated Emission	Power:	AC 120V/60Hz
Model Number:	PC10110	Temp.(°C)/Hum.(%RH):	26(°C)/60%RH
Mode:	Mode 4	Date:	2010/08/12
Frequency:	2480 MHz	Test By:	Gary Wu
Ant.Polar.:	Horizontal		

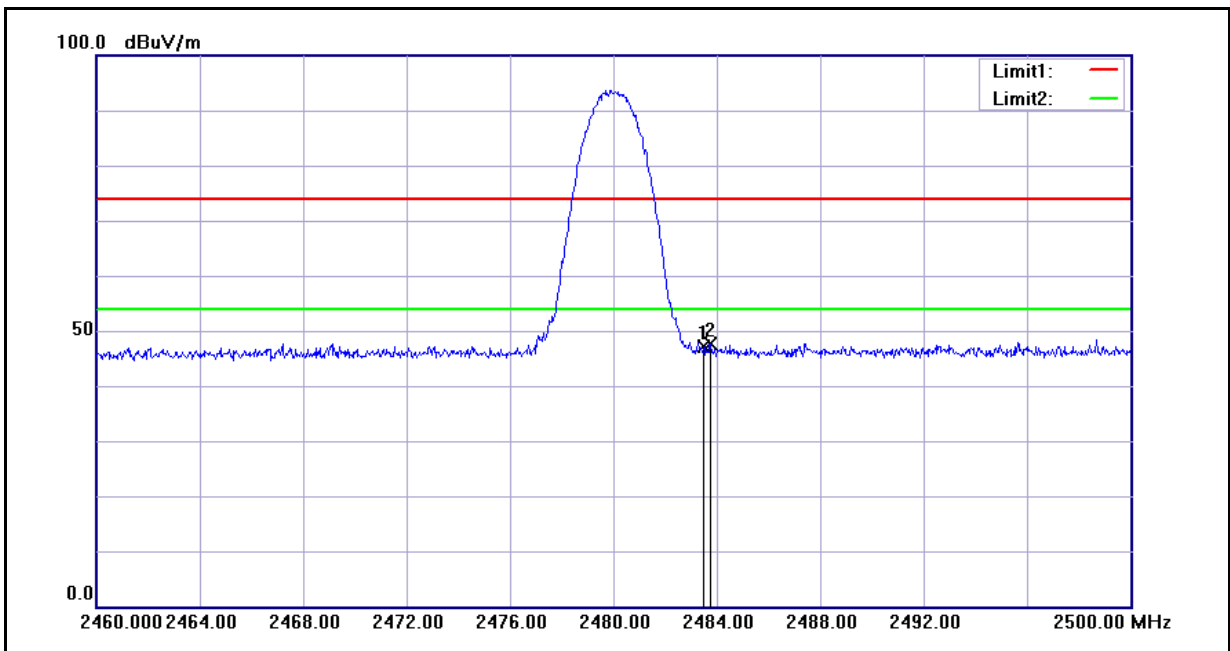

No.	Frequency (MHz)	Reading (dBuV)	Correct Factor(dB/m)	Result (dBuV/m)	Limit (dBuV/m)	Margin (dB)	Remark
1	2483.500	47.02	0.16	47.18	74.00	-26.82	peak
2	2483.760	47.57	0.16	47.73	74.00	-26.27	peak



Standard:	FCC Part 15C	Test Distance:	3m
Test item:	Radiated Emission	Power:	AC 120V/60Hz
Model Number:	PC10110	Temp.(°C)/Hum.(%RH):	26(°C)/60%RH
Mode:	Mode 4	Date:	2010/08/12
Frequency:	2480 MHz	Test By:	Gary Wu
Ant.Polar.:	Vertical		

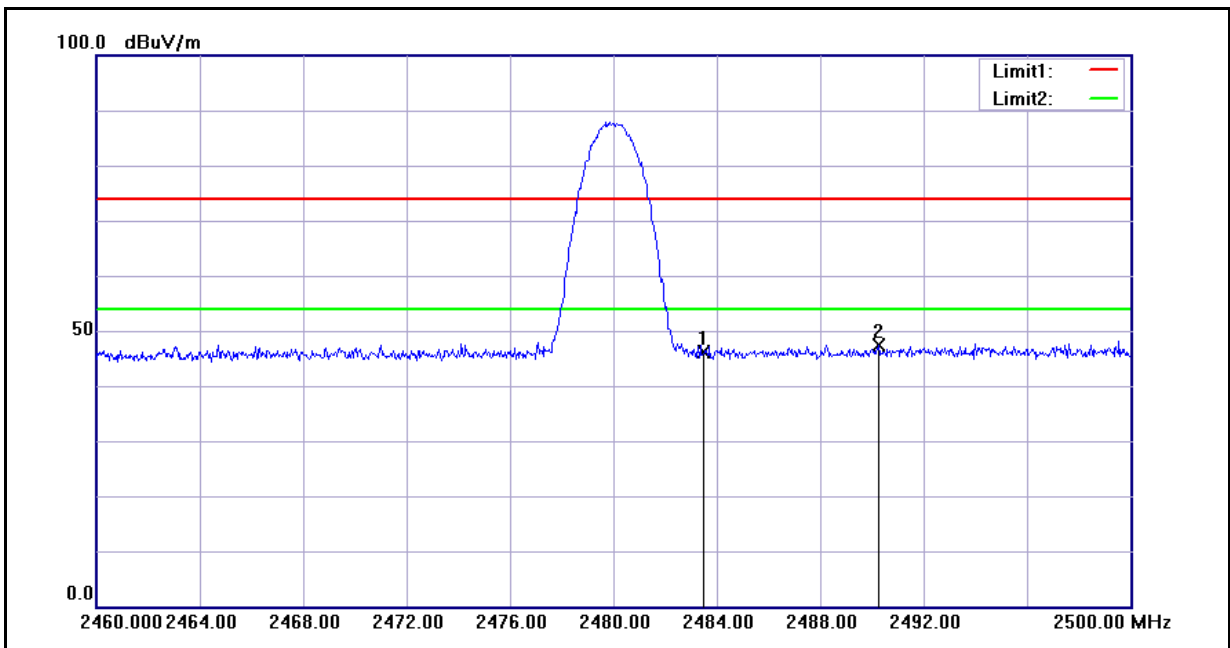

No.	Frequency (MHz)	Reading (dBuV)	Correct Factor(dB/m)	Result (dBuV/m)	Limit (dBuV/m)	Margin (dB)	Remark
1	2483.500	45.97	0.16	46.13	74.00	-27.87	peak
2	2490.280	47.08	0.18	47.26	74.00	-26.74	peak

### 13 99 % Occupied Bandwidth Measurement

#### 13.1.Limit

N/A

#### 13.2.Test Setup

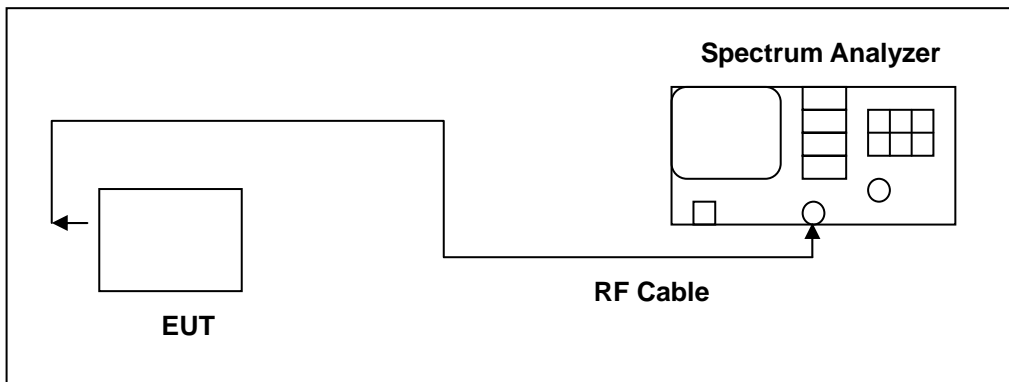

#### 13.3.Test Instruments

Equipment	Manufacturer	Model Number	Serial Number	Cal. Date	Remark
Spectrum Analyzer	Agilent	E4445A	MY46181986	05/14/2009	(2)
Test Site	ATL	TE06	TE06	N.C.R.	-----

Remark: (1) Calibration period 1 year. (2) Calibration period 2 years.

NOTE: N.C.R. = No Calibration Request.

#### 13.4.Test Procedure

The transmitter output is connected to the spectrum analyzer. The RBW is set to 1% to 3% of the 99 % bandwidth. The VBW is set to 3 times the RBW. The sweep time is coupled.

**13.5. Test Result**

Model Number	PC10110		
Test Item	99 % Occupied Bandwidth		
Test Mode	Mode 3: GFSK Link Mode		
Date of Test	08/03/2010	Test Site	TE06
Frequency (MHz)	Measurement (MHz)	Limit (MHz)	
2402	0.8608164	-----	
2441	0.8665288	-----	
2480	0.8597159	-----	

Model Number	PC10110		
Test Item	99 % Occupied Bandwidth		
Test Mode	Mode 4: $\pi/4$ -DQPSK Link Mode		
Date of Test	08/03/2010	Test Site	TE06
Frequency (MHz)	Measurement (MHz)	Limit (MHz)	
2402	1.1677	-----	
2441	1.1700	-----	
2480	1.1735	-----	

**13.6. Test Graphs**

Mode 3: GFSK Link Mode	
2402	<p>Agilent 18:04:13 Aug 3, 2010 R T</p> <p>Ch Freq 2.402 GHz Trig Free</p> <p>Occupied Bandwidth</p> <p>Ref 20.5 dBm #Atten 30 dB</p> <p>#Peak Log 10 dB/Offset 0.5 dB</p> <p>Center 2.402 GHz Span 3 MHz #Res BW 10 kHz #VBW 30 kHz Sweep 31.08 ms (401 pts)</p> <p><b>Occupied Bandwidth</b> 860.8164 kHz Occ BW % Pwr 99.00 % x dB -26.00 dB</p> <p>Transmit Freq Error -16.638 kHz x dB Bandwidth 1.186 MHz</p> <p>Freq/Channel Center Freq 2.40200000 GHz Start Freq 2.40050000 GHz Stop Freq 2.40350000 GHz CF Step 300.000000 kHz Auto Man Freq Offset 0.00000000 Hz Signal Track On Off</p>
2441	<p>Agilent 18:03:39 Aug 3, 2010 R T</p> <p>Ch Freq 2.441 GHz Trig Free</p> <p>Occupied Bandwidth</p> <p>Ref 20.5 dBm #Atten 30 dB</p> <p>#Peak Log 10 dB/Offset 0.5 dB</p> <p>Center 2.441 GHz Span 3 MHz #Res BW 10 kHz #VBW 30 kHz Sweep 31.08 ms (401 pts)</p> <p><b>Occupied Bandwidth</b> 866.5288 kHz Occ BW % Pwr 99.00 % x dB -26.00 dB</p> <p>Transmit Freq Error -15.235 kHz x dB Bandwidth 1.187 MHz</p> <p>Freq/Channel Center Freq 2.44100000 GHz Start Freq 2.43950000 GHz Stop Freq 2.44250000 GHz CF Step 300.000000 kHz Auto Man Freq Offset 0.00000000 Hz Signal Track On Off</p>
2480	<p>Agilent 18:03:05 Aug 3, 2010 R T</p> <p>Ch Freq 2.48 GHz Trig Free</p> <p>Occupied Bandwidth</p> <p>Ref 20.5 dBm #Atten 30 dB</p> <p>#Peak Log 10 dB/Offset 0.5 dB</p> <p>Center 2.48 GHz Span 3 MHz #Res BW 10 kHz #VBW 30 kHz Sweep 31.08 ms (401 pts)</p> <p><b>Occupied Bandwidth</b> 859.7159 kHz Occ BW % Pwr 99.00 % x dB -26.00 dB</p> <p>Transmit Freq Error -13.792 kHz x dB Bandwidth 1.188 MHz</p> <p>Freq/Channel Center Freq 2.48000000 GHz Start Freq 2.47850000 GHz Stop Freq 2.48150000 GHz CF Step 300.000000 kHz Auto Man Freq Offset 0.00000000 Hz Signal Track On Off</p>

Mode 4: $\pi/4$ -DQPSK Link Mode	
2402	<p>Agilent 18:01:24 Aug 3, 2010</p> <p>Ch Freq 2.402 GHz</p> <p>Occupied Bandwidth</p> <p>Ref 20.5 dBm #Atten 30 dB</p> <p>#Peak Log 10 dB/Offset 0.5 dB</p> <p>Center 2.402 GHz Span 3 MHz #Res BW 10 kHz #VBW 30 kHz Sweep 31.08 ms (401 pts)</p> <p><b>Occupied Bandwidth</b> 1.1677 MHz</p> <p>Occ BW % Pwr 99.00 % x dB -26.00 dB</p> <p>Transmit Freq Error -19.369 kHz x dB Bandwidth 1.359 MHz</p> <p>Freq/Channel: Center Freq 2.40200000 GHz, Start Freq 2.40050000 GHz, Stop Freq 2.40350000 GHz, CF Step 300.000000 kHz, Freq Offset 0.00000000 Hz, Signal Track On</p>
2441	<p>Agilent 18:01:56 Aug 3, 2010</p> <p>Ch Freq 2.441 GHz</p> <p>Occupied Bandwidth</p> <p>Ref 20.5 dBm #Atten 30 dB</p> <p>#Peak Log 10 dB/Offset 0.5 dB</p> <p>Center 2.441 GHz Span 3 MHz #Res BW 10 kHz #VBW 30 kHz Sweep 31.08 ms (401 pts)</p> <p><b>Occupied Bandwidth</b> 1.1700 MHz</p> <p>Occ BW % Pwr 99.00 % x dB -26.00 dB</p> <p>Transmit Freq Error -18.191 kHz x dB Bandwidth 1.357 MHz</p> <p>Freq/Channel: Center Freq 2.44100000 GHz, Start Freq 2.43950000 GHz, Stop Freq 2.44250000 GHz, CF Step 300.000000 kHz, Freq Offset 0.00000000 Hz, Signal Track On</p>
2480	<p>Agilent 18:02:27 Aug 3, 2010</p> <p>Ch Freq 2.48 GHz</p> <p>Occupied Bandwidth</p> <p>Ref 20.5 dBm #Atten 30 dB</p> <p>#Peak Log 10 dB/Offset 0.5 dB</p> <p>Center 2.48 GHz Span 3 MHz #Res BW 10 kHz #VBW 30 kHz Sweep 31.08 ms (401 pts)</p> <p><b>Occupied Bandwidth</b> 1.1735 MHz</p> <p>Occ BW % Pwr 99.00 % x dB -26.00 dB</p> <p>Transmit Freq Error -15.073 kHz x dB Bandwidth 1.357 MHz</p> <p>Freq/Channel: Center Freq 2.48000000 GHz, Start Freq 2.47850000 GHz, Stop Freq 2.48150000 GHz, CF Step 300.000000 kHz, Freq Offset 0.00000000 Hz, Signal Track On</p>

## **14 Antenna Measurement**

### **14.1.Limit**

For intentional device, according to 15.203, an intentional radiator shall be designed to ensure that no antenna other than that furnished by the responsible party shall be used with the device.

And According to 15.247 (b), if transmitting antennas of directional gain greater than 6 dBi are used, the power shall be reduced by the amount in dB that the directional gain of the antenna exceeds 6dBi.

### **14.2.Antenna Connector Construction**

The antenna used in this product is **PIFA antenna**. And the maximum Gain of this antenna is only **1.69 dBi**.