

P/N

241994000

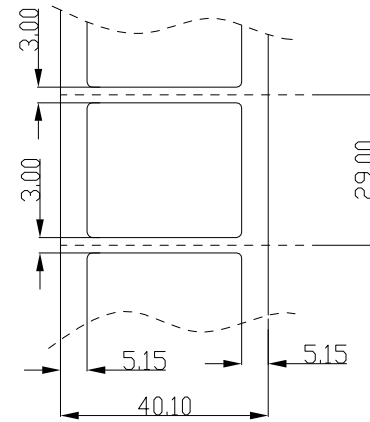
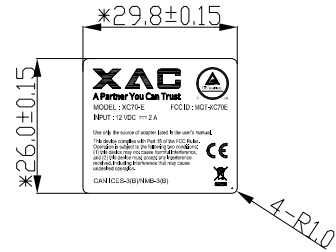

NOTES

- 1.) SURFACE MATERIAL: PET 0.05mmTHK.(+/-10%) WITH BACK ACRYLIC ADHESIVE.
- 2.) PRINT: PERMANENT BLACK OPAQUE INK.
- 3.) FINISH: SURFACE WITH PET COATING.
- 4.) TOTAL THICKNESS TO BE 0.13±0.02mm.
- 5.) LINER SPEC: ROLL TYPE, GLASSING PAPER, 82 gw/m² (REF.) SURFACE WITH SILICON COATING.
- 6.) LABEL MARKING TO COMPLY WITH UL'S RECOGNIZED COMPONENT MARKING AND LABELING SYSTEMS. ALL LABEL MATERIAL AND ADHESIVE MUST BE UL COMPLIANT/CERTIFIED
- 7.) FINISHED: MEET XAC's RoHS REQUIREMENT
- 8.) CRITICAL DIMENSIONS WITH " * " MARK.

3						UNLESS OTHERWISE SPECIFIED TOLERANCES ARE :	MODEL NO	XC70-ID		0 ← mm → 25	XAC XAC Automation Corp. A Partner You Can Trust		
							APPROVED	DATE	DO NOT SCALE DRAWING				
2						MATERIAL :	CHECKED	DATE	THIRD ANGLE PROJECTION	TITLE LABEL RATING XC70-E(RDHS)			
1						SEE NOTE	DESIGNER	DATE					
REV LTR	DATE	EC NO.	REV. DESCRIPTION	DESIGNER	APPROVED	FINISH :	DATE	PAPER SIZE:	A3	DWG NO.	241994000_A01	VER.	A01