



SPORTON International Inc.

No. 52, Hwa Ya 1st Rd., Kwei-Shan Hsiang, TaoYuan Hsien, Taiwan, R.O.C.
Ph: 886-3-327-3456 / FAX: 886-3-327-0973 / www.sporton.com.tw

FCC RADIO TEST REPORT

Applicant's company	Z-COM, Inc.
Applicant Address	5F, No.8 HSIN-ANN RD.HSINCHU SCIENCE PARK, HSINCHU, TAIWAN
FCC ID	M4Y-ZCN722MV1
Manufacturer's company	Z-COM, Inc.
Manufacturer Address	5F, No.8 HSIN-ANN RD.HSINCHU SCIENCE PARK, HSINCHU, TAIWAN

Product Name	IEEE 802.11b/g/n 2.4GHz Wireless LAN High Power USB Module
Brand Name	ZCOM
Model Name	ZCN-722M
Test Rule	47 CFR FCC Part 15 Subpart C § 15.247
Test Freq. Range	2400 ~ 2483.5MHz
Received Date	Jul. 28, 2011
Final Test Date	Aug. 01, 2011
Submission Type	Original Equipment



Statement

Test result included in this report is for the IEEE 802.11n and IEEE 802.11b/g part of the product.

The test result in this report refers exclusively to the presented test model / sample.

Without written approval of SPORTON International Inc., the test report shall not be reproduced except in full.

The measurements and test results shown in this test report were made in accordance with the procedures and found in compliance with the limit given in **ANSI C63.10-2009** and **47 CFR FCC Part 15 Subpart C**.

The test equipment used to perform the test is calibrated and traceable to NML/ROC.



Table of Contents

1. CERTIFICATE OF COMPLIANCE	1
2. SUMMARY OF THE TEST RESULT	2
3. GENERAL INFORMATION	3
3.1. Product Details.....	3
3.2. Accessories.....	6
3.3. Table for Filed Antenna.....	6
3.4. Table for Carrier Frequencies	6
3.5. Table for Test Modes	7
3.6. Table for Testing Locations.....	8
3.7. Table for Supporting Units	8
3.8. Table for Parameters of Test Software Setting	8
3.9. Test Configurations	11
4. TEST RESULT	15
4.1. AC Power Line Conducted Emissions Measurement.....	15
4.2. Peak Output Power Measurement	19
4.3. Power Spectral Density Measurement	30
4.4. 6dB Spectrum Bandwidth Measurement	51
4.5. Radiated Emissions Measurement	72
4.6. Band Edge Emissions Measurement	138
4.7. Antenna Requirements	179
5. LIST OF MEASURING EQUIPMENTS	180
6. TEST LOCATION.....	182
7. TAF CERTIFICATE OF ACCREDITATION	183
APPENDIX A. TEST PHOTOS	A1 ~ A11
APPENDIX B. MAXIMUM PERMISSIBLE EXPOSURE	B1 ~ B3



History of This Test Report

REPORT NO.	VERSION	DESCRIPTION	ISSUED DATE
FR160718-02	Rev. 01	Initial issue of report	Aug. 02, 2011



1. CERTIFICATE OF COMPLIANCE

Product Name : IEEE 802.11b/g/n 2.4GHz Wireless LAN High Power USB Module
Brand Name : ZCOM
Model Name : ZCN-722M
Applicant : Z-COM, Inc.
Test Rule Part(s) : 47 CFR FCC Part 15 Subpart C § 15.247

Sporton International as requested by the applicant to evaluate the EMC performance of the product sample received on Jul. 28, 2011 would like to declare that the tested sample has been evaluated and found to be in compliance with the tested rule parts. The data recorded as well as the test configuration specified is true and accurate for showing the sample's EMC nature.

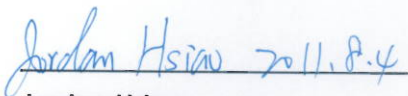
A handwritten signature in blue ink that reads "Jordan Hsiao 2011.8.4". The signature is written over a horizontal line.

Jordan Hsiao

SPORTON INTERNATIONAL INC.

2. SUMMARY OF THE TEST RESULT

Applied Standard: 47 CFR FCC Part 15 Subpart C				
Part	Rule Section	Description of Test	Result	Under Limit
4.1	15.207	AC Power Line Conducted Emissions	Complies	6.47 dB
4.2	15.247(b)(3)	Peak Output Power	Complies	0.00 dB
4.3	15.247(e)	Power Spectral Density	Complies	5.88 dB
4.4	15.247(a)(2)	6dB Spectrum Bandwidth	Complies	-
4.5	15.247(d)	Radiated Emissions	Complies	3.59 dB
4.6	15.247(d)	Band Edge Emissions	Complies	0.05 dB
4.7	15.203	Antenna Requirements	Complies	-

Test Items	Uncertainty	Remark
AC Power Line Conducted Emissions	±2.3dB	Confidence levels of 95%
Maximum Conducted Output Power	±0.8dB	Confidence levels of 95%
Power Spectral Density	±0.5dB	Confidence levels of 95%
6dB Spectrum Bandwidth	±8.5×10 ⁻⁸	Confidence levels of 95%
Radiated Emissions (9kHz~30MHz)	±0.8dB	Confidence levels of 95%
Radiated Emissions (30MHz~1000MHz)	±1.9dB	Confidence levels of 95%
Radiated / Band Edge Emissions (1GHz~18GHz)	±1.9dB	Confidence levels of 95%
Radiated Emissions (18GHz~40GHz)	±1.9dB	Confidence levels of 95%
Temperature	±0.7°C	Confidence levels of 95%
Humidity	±3.2%	Confidence levels of 95%
DC / AC Power Source	±1.4%	Confidence levels of 95%

3. GENERAL INFORMATION

3.1. Product Details

IEEE 802.11n

Items	Description
Product Type	WLAN (1TX, 1RX)
Radio Type	Intentional Transceiver
Power Type	From host system
Modulation	see the below table for IEEE 802.11n
Data Modulation	OFDM (BPSK / QPSK / 16QAM / 64QAM)
Data Rate (Mbps)	see the below table for IEEE 802.11n
Frequency Range	2400 ~ 2483.5MHz
Channel Number	11 for 20MHz bandwidth ; 7 for 40MHz bandwidth
Channel Band Width (99%)	<For Ant. 1> MCS0 (20MHz): 17.76 MHz ; MCS0 (40MHz): 36.32 MHz <For Ant. 2> MCS0 (20MHz): 17.76 MHz ; MCS0 (40MHz): 36.32 MHz <For Ant. 3> MCS0 (20MHz): 17.76 MHz ; MCS0 (40MHz): 36.32 MHz <For Ant. 4> MCS0 (20MHz): 17.76 MHz ; MCS0 (40MHz): 36.32 MHz <For Ant. 5> MCS0 (20MHz): 17.68 MHz ; MCS0 (40MHz): 36.40 MHz
Peak Output Power	<For Ant. 1> MCS0 (20MHz): 24.60 dBm ; MCS0 (40MHz): 24.30 dBm <For Ant. 2> MCS0 (20MHz): 29.10 dBm ; MCS0 (40MHz): 27.29 dBm <For Ant. 3> MCS0 (20MHz): 27.30 dBm ; MCS0 (40MHz): 25.78 dBm <For Ant. 4> MCS0 (20MHz): 29.43 dBm ; MCS0 (40MHz): 28.02 dBm <For Ant. 5> MCS0 (20MHz): 28.62 dBm ; MCS0 (40MHz): 28.41 dBm
Carrier Frequencies	Please refer to section 3.4
Antenna	Please refer to section 3.3

IEEE 802.11b/g

Items	Description
Product Type	WLAN (1TX, 1RX)
Radio Type	Intentional Transceiver
Power Type	From host system
Modulation	DSSS for IEEE 802.11b ; OFDM for IEEE 802.11g
Data Modulation	DSSS (BPSK / QPSK / CCK) ; OFDM (BPSK / QPSK / 16QAM / 64QAM)
Data Rate (Mbps)	DSSS (1/ 2/ 5.5/11) ; OFDM (6/9/12/18/24/36/48/54)
Frequency Range	2400 ~ 2483.5MHz
Channel Number	11
Channel Band Width (99%)	<For Ant. 1 > 11b: 15.72 MHz ; 11g: 16.56 MHz <For Ant. 2 > 11b: 15.76 MHz ; 11g: 16.56 MHz <For Ant. 3 > 11b: 15.72 MHz ; 11g: 16.56 MHz <For Ant. 4 > 11b: 15.68 MHz ; 11g: 16.56 MHz <For Ant. 5 > 11b: 15.76 MHz ; 11g: 16.56 MHz
Peak Output Power	<For Ant. 1 > 11b: 24.52 dBm ; 11g: 24.70 dBm <For Ant. 2 > 11b: 24.07 MHz ; 11g: 29.14 MHz <For Ant. 3 > 11b: 27.60 MHz ; 11g: 27.50 MHz <For Ant. 4 > 11b: 27.75 MHz ; 11g: 29.51 MHz <For Ant. 5 > 11b: 23.12 MHz ; 11g: 28.66 MHz
Carrier Frequencies	Please refer to section 3.4
Antenna	Please refer to section 3.3

Antenna & Band width

Antenna	Single (TX)	
Band width Mode	20 MHz	40 MHz
IEEE 802.11b	V	X
IEEE 802.11g	V	X
IEEE 802.11n	V	V

IEEE 802.11n spec

MCS Index	Nss	Modulation	R	NBPS	NCBPS		NDBPS		Datarate(Mbps)			
					20MHz	40MHz	20MHz	40MHz	800nsGI		400nsGI	
									20MHz	40MHz	20MHz	40MHz
0	1	BPSK	1/2	1	52	108	26	54	6.5	13.5	7.200	15
1	1	QPSK	1/2	2	104	216	52	108	13.0	27.0	14.400	30
2	1	QPSK	3/4	2	104	216	78	162	19.5	40.5	21.700	45
3	1	16-QAM	1/2	4	208	432	104	216	26.0	54.0	28.900	60
4	1	16-QAM	3/4	4	208	432	156	324	39.0	81.0	43.300	90
5	1	64-QAM	2/3	6	312	648	208	432	52.0	108.0	57.800	120
6	1	64-QAM	3/4	6	312	648	234	486	58.5	121.5	65.000	135
7	1	64-QAM	5/6	6	312	648	260	540	65.0	135.0	72.200	150
8	2	BPSK	1/2	1	104	216	52	108	13.0	27.0	14.444	30
9	2	QPSK	1/2	2	208	432	104	216	26.0	54.0	28.889	60
10	2	QPSK	3/4	2	208	432	156	324	39.0	81.0	43.333	90
11	2	16-QAM	1/2	4	416	864	208	432	52.0	108.0	57.778	120
12	2	16-QAM	3/4	4	416	864	312	648	78.0	162.0	86.667	180
13	2	64-QAM	2/3	6	624	1296	416	864	104.0	216.0	115.556	240
14	2	64-QAM	3/4	6	624	1296	468	972	117.0	243.0	130.000	270
15	2	64-QAM	5/6	6	624	1296	520	1080	130.0	270.0	144.444	300

Symbol	Explanation
NSS	Number of spatial streams
R	Code rate
NBPS	Number of coded bits per single carrier
NCBPS	Number of coded bits per symbol
NDBPS	Number of data bits per symbol
GI	guard interval

3.2. Accessories

N/A

3.3. Table for Filed Antenna

Ant.	Brand	Model Name	Antenna Type	Connector	Gain (dBi)	Cable loss (dB)	Test Gain (dBi)
1	PCTEL Inc.	WISP24013PTNF	PANEL Antenna	N Type	13	1.7	11.3
2	PCTEL Inc.	MHO24002NM	OMNI Antenna	I-PEX	2	1	1
3	PCTEL Inc.	MYP24010PTNF	YAGI Antenna	N Type	10	1.7	8.3
4	Wha Yu	25-030001-89N	DIPOLE Antenna	SMA Plug Reverse	5	0.9	4.1
5	PCTEL Inc.	BMMG24005ML195	DIPOLE Antenna	I-PEX	5	0.82	4.18

3.4. Table for Carrier Frequencies

For IEEE 802.11b/g, use Channel 1~Channel 11.

There are two bandwidth systems for IEEE 802.11n.

For both 20MHz bandwidth systems, use Channel 1~Channel 11.

For both 40MHz bandwidth systems, use Channel 3~Channel 9.

Frequency Band	Channel No.	Frequency	Channel No.	Frequency
2400~2483.5MHz	1	2412 MHz	7	2442 MHz
	2	2417 MHz	8	2447 MHz
	3	2422 MHz	9	2452 MHz
	4	2427 MHz	10	2457 MHz
	5	2432 MHz	11	2462 MHz
	6	2437 MHz	-	-

3.5. Table for Test Modes

Preliminary tests were performed in different data rate to find the worst radiated emission. The data rate shown in the table below is the worst-case rate with respect to the specific test item. Investigation has been done on all the possible configurations for searching the worst cases. The following table is a list of the test modes shown in this test report.

Test Items	Mode	Data Rate	Channel	Antenna
AC Power Line Conducted Emissions	Normal Link	-	-	-
Peak Output Power Power Spectral Density	MCS0/20MHz	6.5 Mbps	1/6/11	1/2/3/4/5
	MCS0/40MHz	13.5 Mbps	3/6/9	1/2/3/4/5
	11b/BPSK	1 Mbps	1/6/11	1/2/3/4/5
	11g/BPSK	6 Mbps	1/6/11	1/2/3/4/5
6dB Spectrum Bandwidth	MCS0/20MHz	6.5 Mbps	1/6/11	1/2/3/4/5
	MCS0/40MHz	13.5 Mbps	3/6/9	1/2/3/4/5
	11b/BPSK	1 Mbps	1/6/11	1/2/3/4/5
	11g/BPSK	6 Mbps	1/6/11	1/2/3/4/5
Radiated Emissions 9kHz~1GHz	Normal Link	-	-	-
Radiated Emissions 1GHz~10 th Harmonic	MCS0/20MHz	6.5 Mbps	1/6/11	1/2/3/4/5
	MCS0/40MHz	13.5 Mbps	3/6/9	1/2/3/4/5
	11b/BPSK	1 Mbps	1/6/11	1/2/3/4/5
	11g/BPSK	6 Mbps	1/6/11	1/2/3/4/5
Band Edge Emissions	MCS0/20MHz	6.5 Mbps	1/11	1/2/3/4/5
	MCS0/40MHz	13.5 Mbps	3/9	1/2/3/4/5
	11b/BPSK	1 Mbps	1/11	1/2/3/4/5
	11g/BPSK	6 Mbps	1/11	1/2/3/4/5

The following test modes were performed for all tests:

For Conducted Emission test and Radiated Emission below 1GHz test:

Due to Ant. 1 is the highest gain antenna, so it was performed for Conducted emission test and Radiated emission below 1GHz test.

For Radiated Emission above 1GHz test:

Mode 1. EUT with Ant. 1

Mode 2. EUT with Ant. 2

Mode 3. EUT with Ant. 3

Mode 4. EUT with Ant. 4

Mode 5. EUT with Ant. 5

All the test results were recorded in the report.

3.6. Table for Testing Locations

Test Site No.	Site Category	Location	FCC Reg. No.	IC File No.	VCCI Reg. No
03CH01-CB	SAC	Hsin Chu	187376	IC 4086D	-
CO01-CB	Conduction	Hsin Chu	187376	IC 4086D	-
TH01-CB	OVEN Room	Hsin Chu	-	-	-

Open Area Test Site (OATS); Semi Anechoic Chamber (SAC); Fully Anechoic Chamber (FAC).

Please refer section 6 for Test Site Address.

3.7. Table for Supporting Units

Support Unit	Brand	Model	FCC ID
Notebook	DELL	M1330	E2K4965AGNM
Mouse	Logitech	M-U0026	DoC
Wireless AP	Planex	GW-AP54SGX	N/A

3.8. Table for Parameters of Test Software Setting

During testing, Channel & Power Controlling Software provided by the customer was used to control the operating channel as well as the output power level. The RF output power selection is for the setting of RF output power expected by the customer and is going to be fixed on the firmware of the final end product.

<For Ant. 1>

Power Parameters of IEEE 802.11n

Test Software Version	Revision 0.8 BUILD #127 ART_11n		
Frequency	2412 MHz	2437 MHz	2462 MHz
MCS0 20MHz	15	15.5	15.5
Frequency	2422 MHz	2437 MHz	2452 MHz
MCS0 40MHz	14	15.5	14

Power Parameters of IEEE 802.11b/g

Test Software Version	Revision 0.8 BUILD #127 ART_11n		
Frequency	2412 MHz	2437 MHz	2462 MHz
IEEE 802.11b	22	21.5	21.5
IEEE 802.11g	15	15.5	16

<For Ant. 2>

Power Parameters of IEEE 802.11n

Test Software Version	Revision 0.8 BUILD #127 ART_11n		
Frequency	2412 MHz	2437 MHz	2462 MHz
MCS0 20MHz	20	23	19
Frequency	2422 MHz	2437 MHz	2452 MHz
MCS0 40MHz	16.5	20	16

Power Parameters of IEEE 802.11b/g

Test Software Version	Revision 0.8 BUILD #127 ART_11n		
Frequency	2412 MHz	2437 MHz	2462 MHz
IEEE 802.11b	22	22	22
IEEE 802.11g	19.5	23	19.5

<For Ant. 3>

Power Parameters of IEEE 802.11n

Test Software Version	Revision 0.8 BUILD #127 ART_11n		
Frequency	2412 MHz	2437 MHz	2462 MHz
MCS0 20MHz	16	18	16.5
Frequency	2422 MHz	2437 MHz	2452 MHz
MCS0 40MHz	13.5	17	13.5

Power Parameters of IEEE 802.11b/g

Test Software Version	Revision 0.8 BUILD #127 ART_11n		
Frequency	2412 MHz	2437 MHz	2462 MHz
IEEE 802.11b	18.5	18	19
IEEE 802.11g	17	18.5	17.5

<For Ant. 4>

Power Parameters of IEEE 802.11n

Test Software Version	Revision 0.8 BUILD #127 ART_11n		
Frequency	2412 MHz	2437 MHz	2462 MHz
MCS0 20MHz	20	24	21
Frequency	2422 MHz	2437 MHz	2452 MHz
MCS0 40MHz	20	24	21

Power Parameters of IEEE 802.11b/g

Test Software Version	Revision 0.8 BUILD #127 ART_11n		
Frequency	2412 MHz	2437 MHz	2462 MHz
IEEE 802.11b	23	25	23
IEEE 802.11g	20	24	21

<For Ant. 5>

Power Parameters of IEEE 802.11n

Test Software Version	ART Revision 0.8 BUILD #127 ART11n		
Frequency	2412 MHz	2437 MHz	2462 MHz
MCS0 20MHz	21	21	21
Frequency	2422 MHz	2437 MHz	2452 MHz
MCS0 40MHz	20.5	21.5	21.5

Power Parameters of IEEE 802.11b/g

Test Software Version	ART Revision 0.8 BUILD #127 ART11n		
Frequency	2412 MHz	2437 MHz	2462 MHz
IEEE 802.11b	22	22	22
IEEE 802.11g	21	21	21

During the test, "Revision 0.8 BUILD #127 ART_11n" under WIN XP was executed the test program to control the EUT continuously transmit RF signal.

3.9. Test Configurations

3.9.1. Radiation Emissions Test Configuration

<For Ant. 1 >

Test Configuration: 30MHz~1GHz

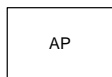
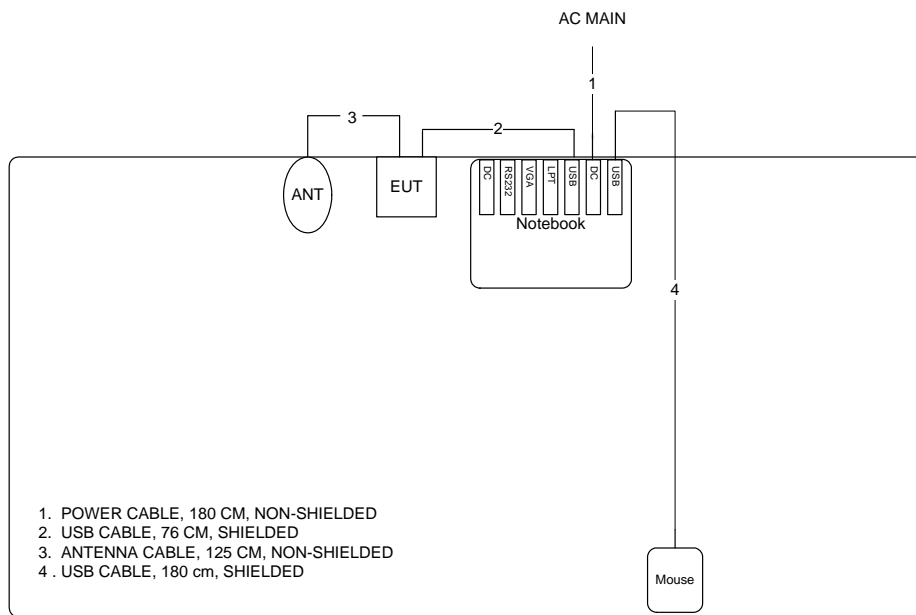

Test Configuration: above 1GHz

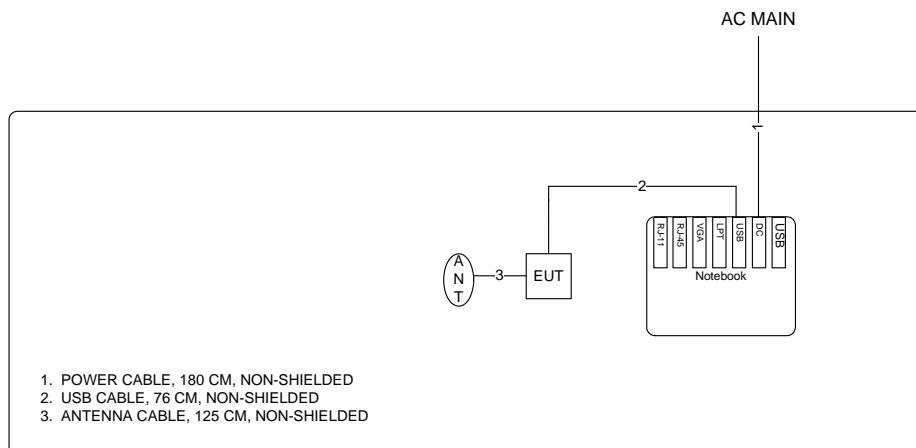

<For Ant. 2>

Test Configuration: above 1GHz

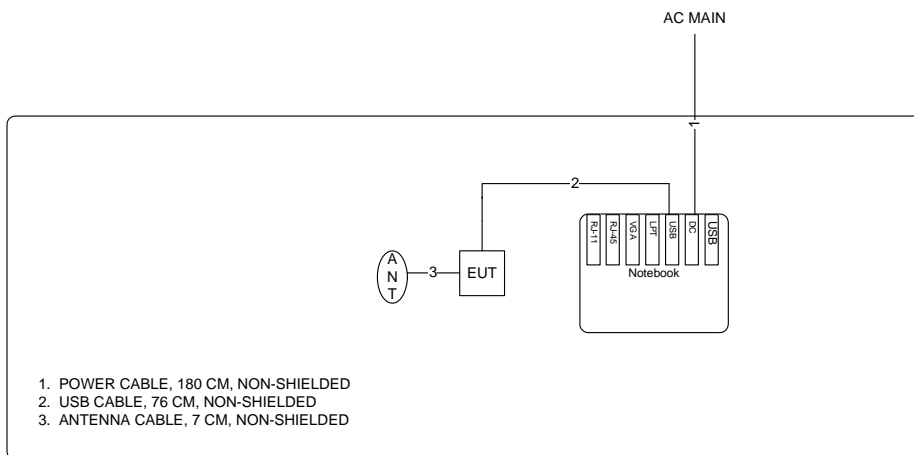

<For Ant. 3>

Test Configuration: above 1GHz

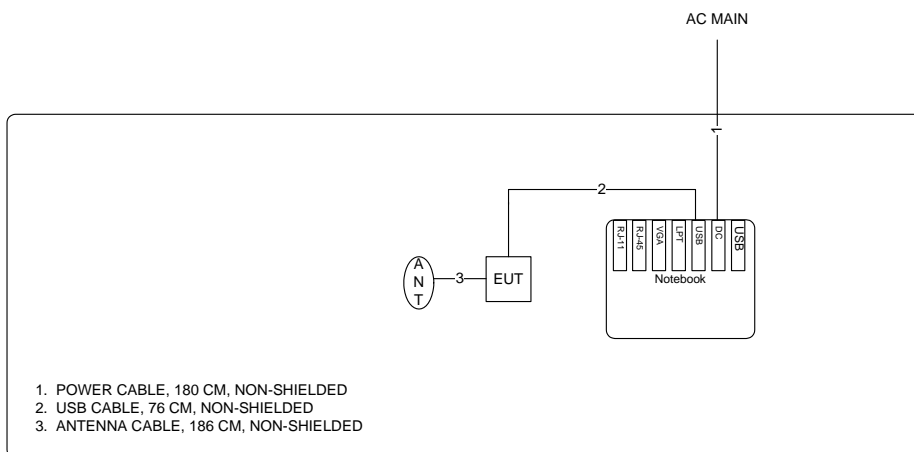

<For Ant. 4>

Test Configuration: above 1GHz

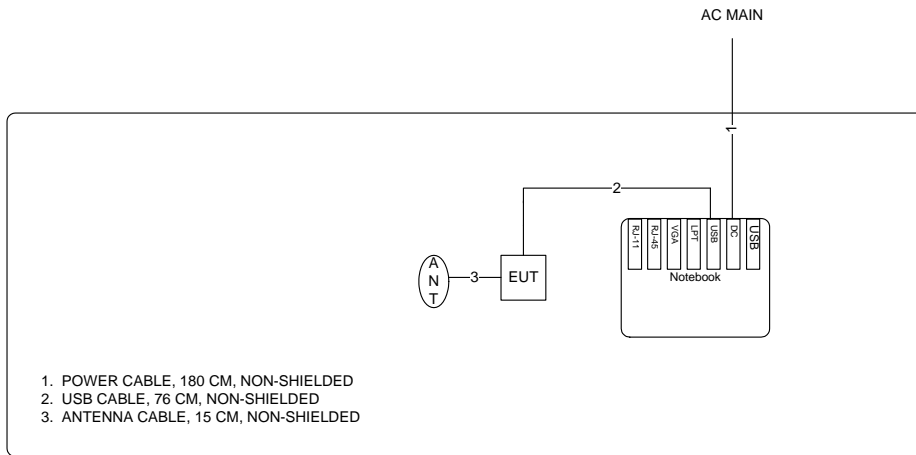

<For Ant. 5>

Test Configuration: above 1GHz

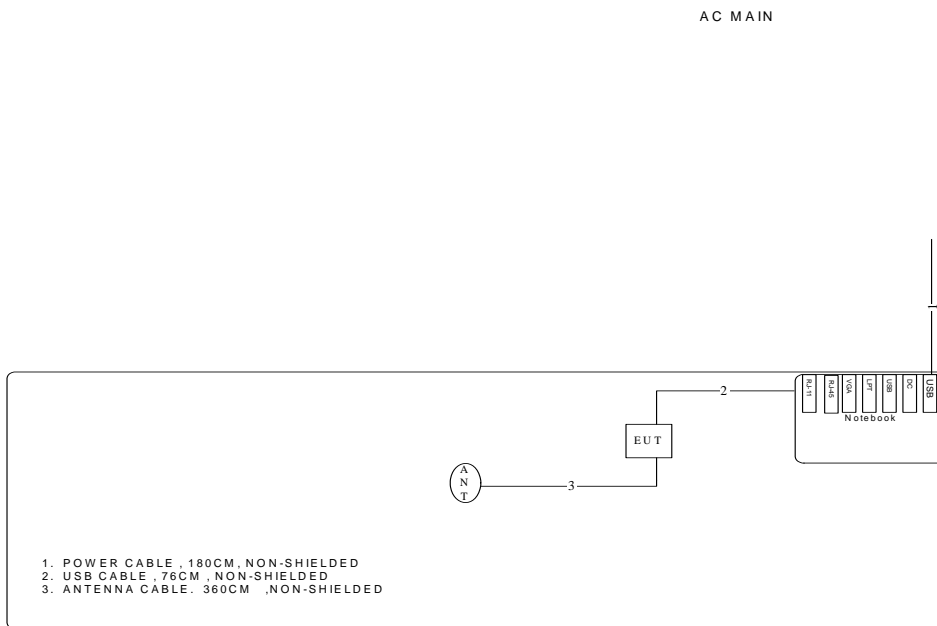

3.9.2. AC Power Line Conduction Emissions Test Configuration

<For Ant. 1 >

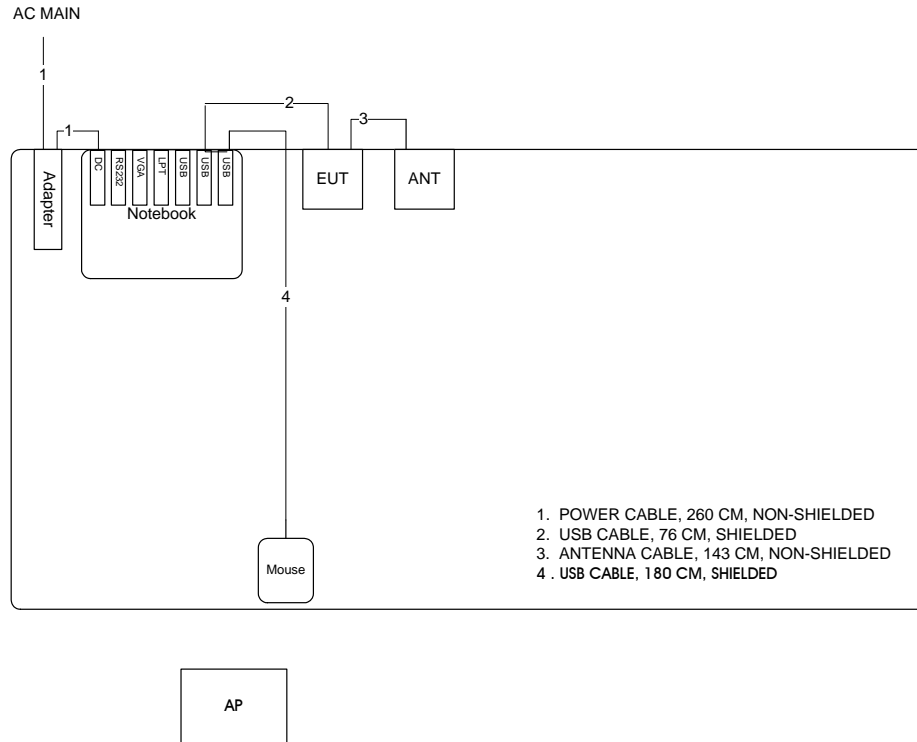

4. TEST RESULT

4.1. AC Power Line Conducted Emissions Measurement

4.1.1. Limit

For this product which is designed to be connected to the AC power line, the radio frequency voltage that is conducted back onto the AC power line on any frequency or frequencies within the band 150 kHz to 30 MHz shall not exceed below limits table.

Frequency (MHz)	QP Limit (dBuV)	AV Limit (dBuV)
0.15~0.5	66~56	56~46
0.5~5	56	46
5~30	60	50

4.1.2. Measuring Instruments and Setting

Please refer to section 5 of equipments list in this report. The following table is the setting of the receiver.

Receiver Parameters	Setting
Attenuation	10 dB
Start Frequency	0.15 MHz
Stop Frequency	30 MHz
IF Bandwidth	9 KHz

4.1.3. Test Procedures

1. Configure the EUT according to ANSI C63.10. The EUT or host of EUT has to be placed 0.4 meter far from the conducting wall of the shielding room and at least 80 centimeters from any other grounded conducting surface.
2. Connect EUT or host of EUT to the power mains through a line impedance stabilization network (LISN).
3. All the support units are connected to the other LISNs. The LISN should provide 50uH/50ohms coupling impedance.
4. The frequency range from 150 KHz to 30 MHz was searched.
5. Set the test-receiver system to Peak Detect Function and Specified Bandwidth with Maximum Hold Mode.
6. The measurement has to be done between each power line and ground at the power terminal.

4.1.4. Test Setup Layout

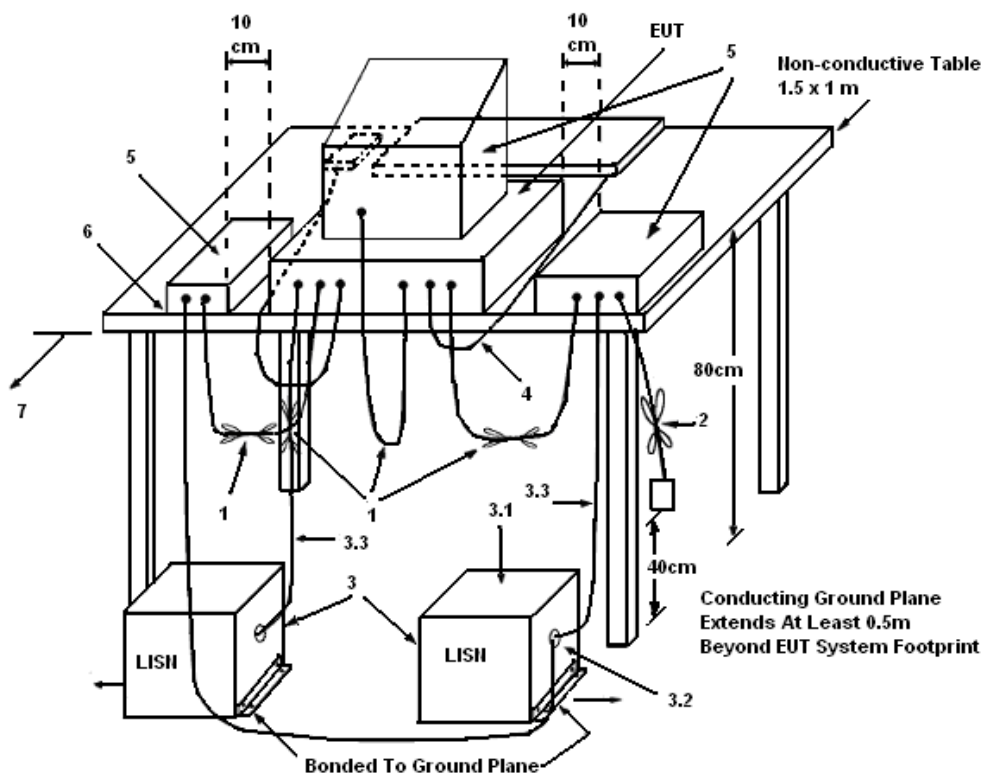

LEGEND:

- (1) Interconnecting cables that hang closer than 40 cm to the ground plane shall be folded back and forth in the center forming a bundle 30 to 40 cm long.
- (2) I/O cables that are not connected to a peripheral shall be bundled in the center. The end of the cable may be terminated, if required, using the correct terminating impedance. The overall length shall not exceed 1 m.
- (3) EUT connected to one LISN. Unused LISN measuring port connectors shall be terminated in 50 Ω . LISN can be placed on top of, or immediately beneath, reference ground plane.
 - (3.1) All other equipment powered from additional LISN(s).
 - (3.2) Multiple outlet strip can be used for multiple power cords of non-EUT equipment.
 - (3.3) LISN at least 80 cm from nearest part of EUT chassis.
- (4) Cables of hand-operated devices, such as keyboards, mice, etc., shall be placed as for normal use.
- (5) Non-EUT components of EUT system being tested.
- (6) Rear of EUT, including peripherals, shall all be aligned and flush with rear of tabletop.
- (7) Rear of tabletop shall be 40 cm removed from a vertical conducting plane that is bonded to the ground plane.

4.1.5. Test Deviation

There is no deviation with the original standard.

4.1.6. EUT Operation during Test

The EUT was placed on the test table and programmed in normal function.

4.1.7. Results of AC Power Line Conducted Emissions Measurement

Temperature	23°C	Humidity	61%
Test Engineer	Peter Wu	Phase	Line
Configuration	Normal Link / Ant. 1		

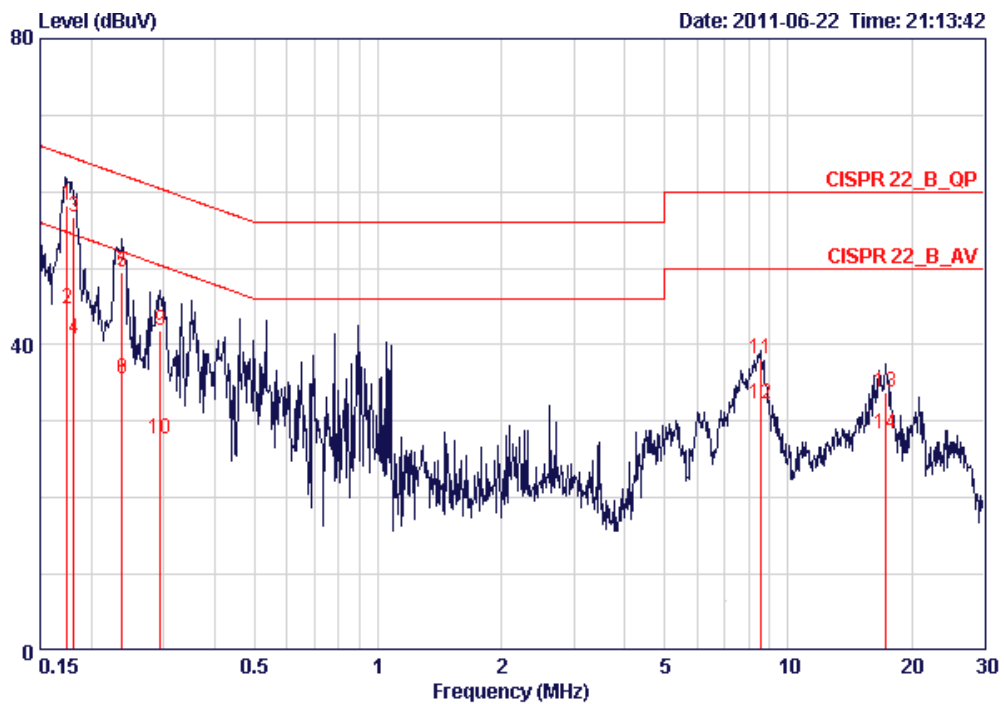

	Freq	Level	Over	Limit	Read	LISN	Cable	Remark
	MHz	dBuV	Limit	Line	Level	Factor	Loss	
			dB	dBuV	dBuV	dB	dB	
1	0.17475	58.26	-6.47	64.73	58.00	0.06	0.20	QP
2	0.17475	44.64	-10.09	54.73	44.38	0.06	0.20	AVERAGE
3	0.18152	56.78	-7.64	64.42	56.52	0.06	0.20	QP
4	0.18152	40.84	-13.58	54.42	40.58	0.06	0.20	AVERAGE
5	0.23784	49.52	-12.65	62.17	49.28	0.04	0.20	QP
6	0.23784	35.61	-16.56	52.17	35.37	0.04	0.20	AVERAGE
7	0.23784	49.44	-12.73	62.17	49.20	0.04	0.20	QP
8	0.23784	35.45	-16.72	52.17	35.21	0.04	0.20	AVERAGE
9	0.29398	41.79	-18.62	60.41	41.55	0.04	0.20	QP
10	0.29398	27.68	-22.73	50.41	27.44	0.04	0.20	AVERAGE
11	8.546	38.20	-21.80	60.00	37.59	0.31	0.30	QP
12	8.546	32.18	-17.82	50.00	31.57	0.31	0.30	AVERAGE
13	17.291	33.73	-26.28	60.00	32.54	0.69	0.50	QP
14	17.291	28.32	-21.69	50.00	27.13	0.69	0.50	AVERAGE

Temperature	23°C	Humidity	61%
Test Engineer	Peter Wu	Phase	Neutral
Configuration	Normal Link / Ant. 1		

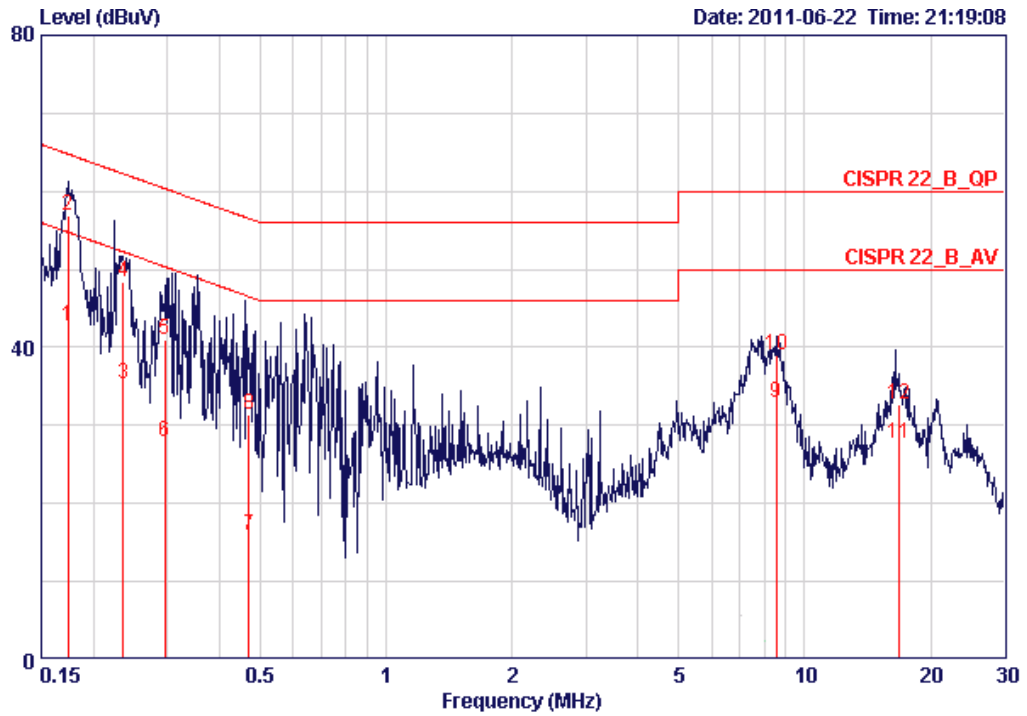

	Freq	Level	Over Limit	Limit Line	Read Level	LISN Factor	Cable Loss	Remark
	MHz	dBuV	dB	dBuV	dBuV	dB	dB	
1	0.17399	42.63	-12.14	54.77	42.34	0.09	0.20	AVERAGE
2	0.17399	56.99	-7.78	64.77	56.70	0.09	0.20	QP
3	0.23533	35.36	-16.90	52.26	35.08	0.08	0.20	AVERAGE
4	0.23533	48.47	-13.79	62.26	48.19	0.08	0.20	QP
5	0.29571	41.04	-19.32	60.36	40.77	0.07	0.20	QP
6	0.29571	27.81	-22.55	50.36	27.54	0.07	0.20	AVERAGE
7	0.47053	16.02	-30.48	46.50	15.75	0.07	0.20	AVERAGE
8	0.47053	31.48	-25.02	56.50	31.21	0.07	0.20	QP
9	8.546	32.90	-17.10	50.00	32.25	0.35	0.30	AVERAGE
10	8.546	39.01	-20.99	60.00	38.36	0.35	0.30	QP
11	16.750	27.77	-22.23	50.00	26.66	0.66	0.45	AVERAGE
12	16.750	32.62	-27.38	60.00	31.51	0.66	0.45	QP

Note:

Level = Read Level + LISN Factor + Cable Loss.

4.2. Peak Output Power Measurement

4.2.1. Limit

For systems using digital modulation in the 2400-2483.5MHz, the limit for peak output power is 30dBm. The limited has to be reduced by the amount in dB that the gain of the antenna exceed 6dBi. In case of point-to-point operation, the limit has to be reduced by 1dB for every 3dB that the directional gain of the antenna exceeds 6dBi.

4.2.2. Measuring Instruments and Setting

Please refer to section 5 of equipments list in this report. The following table is the setting of the peak power meter.

Power Meter Parameter	Setting
Bandwidth	50MHz bandwidth is greater than the EUT emission bandwidth
Detector	Peak

4.2.3. Test Procedures

Spectrum Parameter	Setting
RF Output Power Method	<input checked="" type="checkbox"/> ANSI C63.10 clause 6.10.2.1 (a) power meter method
RF Output Power Method	<input type="checkbox"/> ANSI C63.10 clause 6.10.2.1 (b) channel integration method
RF Output Power Method	<input type="checkbox"/> ANSI C63.10 clause 6.10.3.1 Method 1 - spectral trace averaging
RF Output Power Method	<input type="checkbox"/> ANSI C63.10 clause 6.10.3.2 Method 2 - zero-span mode with trace averaging

4.2.4. Test Setup Layout

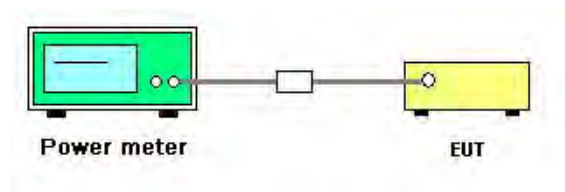

4.2.5. Test Deviation

There is no deviation with the original standard.

4.2.6. EUT Operation during Test

The EUT was programmed to be in continuously transmitting mode.

4.2.7. Test Result of Peak Output Power

<For Ant. 1 >

Temperature	22°C	Humidity	65%
Test Engineer	Serway Li	Configurations	IEEE 802.11n / Ant. 1
Test Date	Jun. 17, 2011		

Configuration IEEE 802.11n MCS0 20MHz / Ant. 1

Channel	Frequency	Conducted Power (dBm)	Max. Limit (dBm)	Result
1	2412 MHz	24.25	24.70	Complies
6	2437 MHz	24.60	24.70	Complies
11	2462 MHz	24.27	24.70	Complies

Configuration IEEE 802.11n MCS0 40MHz / Ant. 1

Channel	Frequency	Conducted Power (dBm)	Max. Limit (dBm)	Result
3	2422 MHz	23.15	24.70	Complies
6	2437 MHz	24.30	24.70	Complies
9	2452 MHz	22.60	24.70	Complies

Temperature	22°C	Humidity	65%
Test Engineer	Serway Li	Configurations	IEEE 802.11b/g / Ant. 1
Test Date	Jun. 17, 2011		

Configuration IEEE 802.11b / Ant. 1

Channel	Frequency	Conducted Power (dBm)	Max. Limit (dBm)	Result
1	2412 MHz	24.52	24.70	Complies
6	2437 MHz	23.56	24.70	Complies
11	2462 MHz	23.22	24.70	Complies

Configuration IEEE 802.11g / Ant. 1

Channel	Frequency	Conducted Power (dBm)	Max. Limit (dBm)	Result
1	2412 MHz	24.30	24.70	Complies
6	2437 MHz	24.50	24.70	Complies
11	2462 MHz	24.70	24.70	Complies

<For Ant. 2>

Temperature	22°C	Humidity	65%
Test Engineer	Serway Li	Configurations	IEEE 802.11n / Ant. 2
Test Date	Jun. 17, 2011		

Configuration IEEE 802.11n MCS0 20MHz / Ant. 2

Channel	Frequency	Conducted Power (dBm)	Max. Limit (dBm)	Result
1	2412 MHz	28.13	30.00	Complies
6	2437 MHz	29.10	30.00	Complies
11	2462 MHz	26.55	30.00	Complies

Configuration IEEE 802.11n MCS0 40MHz / Ant. 2

Channel	Frequency	Conducted Power (dBm)	Max. Limit (dBm)	Result
3	2422 MHz	24.96	30.00	Complies
6	2437 MHz	27.29	30.00	Complies
9	2452 MHz	23.46	30.00	Complies

Temperature	22°C	Humidity	65%
Test Engineer	Serway Li	Configurations	IEEE 802.11b/g / Ant. 2
Test Date	Jun. 17, 2011		

Configuration IEEE 802.11b / Ant. 2

Channel	Frequency	Conducted Power (dBm)	Max. Limit (dBm)	Result
1	2412 MHz	23.70	30.00	Complies
6	2437 MHz	24.06	30.00	Complies
11	2462 MHz	24.07	30.00	Complies

Configuration IEEE 802.11g / Ant. 2

Channel	Frequency	Conducted Power (dBm)	Max. Limit (dBm)	Result
1	2412 MHz	27.77	30.00	Complies
6	2437 MHz	29.14	30.00	Complies
11	2462 MHz	26.91	30.00	Complies

<For Ant. 3>

Temperature	22°C	Humidity	65%
Test Engineer	Serway Li	Configurations	IEEE 802.11n / Ant. 3
Test Date	Jun. 17, 2011		

Configuration IEEE 802.11n MCS0 20MHz / Ant. 3

Channel	Frequency	Conducted Power (dBm)	Max. Limit (dBm)	Result
1	2412 MHz	25.50	27.70	Complies
6	2437 MHz	27.30	27.70	Complies
11	2462 MHz	25.10	27.70	Complies

Configuration IEEE 802.11n MCS0 40MHz / Ant. 3

Channel	Frequency	Conducted Power (dBm)	Max. Limit (dBm)	Result
3	2422 MHz	22.60	27.70	Complies
6	2437 MHz	25.78	27.70	Complies
9	2452 MHz	22.30	27.70	Complies

Temperature	22°C	Humidity	65%
Test Engineer	Serway Li	Configurations	IEEE 802.11b/g / Ant. 3
Test Date	Jun. 17, 2011		

Configuration IEEE 802.11b / Ant. 3

Channel	Frequency	Conducted Power (dBm)	Max. Limit (dBm)	Result
1	2412 MHz	27.60	27.70	Complies
6	2437 MHz	27.30	27.70	Complies
11	2462 MHz	27.45	27.70	Complies

Configuration IEEE 802.11g / Ant. 3

Channel	Frequency	Conducted Power (dBm)	Max. Limit (dBm)	Result
1	2412 MHz	26.25	27.70	Complies
6	2437 MHz	27.50	27.70	Complies
11	2462 MHz	25.95	27.70	Complies

<For Ant. 4>

Temperature	22°C	Humidity	65%
Test Engineer	Serway Li	Configurations	IEEE 802.11n / Ant. 4
Test Date	Jun. 17, 2011		

Configuration IEEE 802.11n MCS0 20MHz / Ant. 4

Channel	Frequency	Conducted Power (dBm)	Max. Limit (dBm)	Result
1	2412 MHz	28.28	30.00	Complies
6	2437 MHz	29.43	30.00	Complies
11	2462 MHz	27.52	30.00	Complies

Configuration IEEE 802.11n MCS0 40MHz / Ant. 4

Channel	Frequency	Conducted Power (dBm)	Max. Limit (dBm)	Result
3	2422 MHz	25.76	30.00	Complies
6	2437 MHz	28.02	30.00	Complies
9	2452 MHz	24.22	30.00	Complies

Temperature	22°C	Humidity	65%
Test Engineer	Serway Li	Configurations	IEEE 802.11b/g / Ant. 4
Test Date	Jun. 17, 2011		

Configuration IEEE 802.11b / Ant. 4

Channel	Frequency	Conducted Power (dBm)	Max. Limit (dBm)	Result
1	2412 MHz	25.23	30.00	Complies
6	2437 MHz	27.75	30.00	Complies
11	2462 MHz	25.28	30.00	Complies

Configuration IEEE 802.11g / Ant. 4

Channel	Frequency	Conducted Power (dBm)	Max. Limit (dBm)	Result
1	2412 MHz	28.02	30.00	Complies
6	2437 MHz	29.51	30.00	Complies
11	2462 MHz	28.10	30.00	Complies

<For Ant. 5>

Temperature	23°C	Humidity	63%
Test Engineer	Satoshi Yang	Configurations	IEEE 802.11n / Ant. 5
Test Date	Aug. 01, 2011		

Configuration IEEE 802.11n MCS0 20MHz / Ant. 5

Channel	Frequency	Conducted Power (dBm)	Max. Limit (dBm)	Result
1	2412 MHz	28.62	30.00	Complies
6	2437 MHz	28.44	30.00	Complies
11	2462 MHz	27.90	30.00	Complies

Configuration IEEE 802.11n MCS0 40MHz / Ant. 5

Channel	Frequency	Conducted Power (dBm)	Max. Limit (dBm)	Result
3	2422 MHz	28.02	30.00	Complies
6	2437 MHz	28.41	30.00	Complies
9	2452 MHz	28.15	30.00	Complies

Temperature	23°C	Humidity	63%
Test Engineer	Satoshi Yang	Configurations	IEEE 802.11b/g / Ant. 5
Test Date	Aug. 01, 2011		

Configuration IEEE 802.11b / Ant. 5

Channel	Frequency	Conducted Power (dBm)	Max. Limit (dBm)	Result
1	2412 MHz	23.12	30.00	Complies
6	2437 MHz	22.72	30.00	Complies
11	2462 MHz	22.22	30.00	Complies

Configuration IEEE 802.11g / Ant. 5

Channel	Frequency	Conducted Power (dBm)	Max. Limit (dBm)	Result
1	2412 MHz	28.66	30.00	Complies
6	2437 MHz	28.35	30.00	Complies
11	2462 MHz	28.66	30.00	Complies

4.3. Power Spectral Density Measurement

4.3.1. Limit

For digitally modulated systems, the power spectral density conducted from the intentional radiator to the antenna shall not be greater than 8 dBm in any 3 kHz band during any time interval of continuous transmission.

4.3.2. Measuring Instruments and Setting

Please refer to section 5 of equipments list in this report. The following table is the setting of Spectrum Analyzer.

Spectrum Parameter	Setting
Attenuation	Auto
Span Frequency	30 kHz
RB	3 kHz
VB	30 kHz
Detector	Peak
Trace	Max Hold
Sweep Time	10s

4.3.3. Test Procedures

1. The transmitter output (antenna port) was connected to the spectrum analyzer.
2. Set RBW of spectrum analyzer to 3kHz and VBW to 30kHz. Set Detector to Peak, Trace to Max Hold.
3. Mark the frequency with maximum peak power as the center of the display of the spectrum.
4. Set the span to 30kHz and the sweep time to 10s and record the maximum peak value.

4.3.4. Test Setup Layout

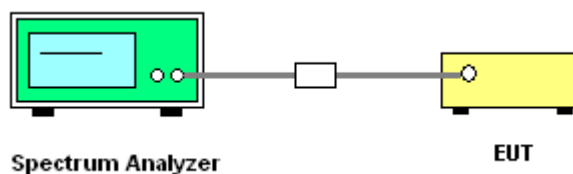

4.3.5. Test Deviation

There is no deviation with the original standard.

4.3.6. EUT Operation during Test

The EUT was programmed to be in continuously transmitting mode.

4.3.7. Test Result of Power Spectral Density

<For Ant. 1>

Temperature	22°C	Humidity	65%
Test Engineer	Serway Li	Configurations	IEEE 802.11n / Ant. 1

Configuration IEEE 802.11n MCS0 20MHz / Ant. 1

Channel	Frequency	Power Density (dBm/3kHz)	Power Density (mW/3kHz)	Max. Limit (dBm/3kHz)	Result
1	2412 MHz	-9.83	0.10	8.00	Complies
6	2437 MHz	-9.00	0.13	8.00	Complies
11	2462 MHz	-9.03	0.13	8.00	Complies

Configuration IEEE 802.11n MCS0 40MHz / Ant. 1

Channel	Frequency	Power Density (dBm/3kHz)	Power Density (mW/3kHz)	Max. Limit (dBm/3kHz)	Result
1	2412 MHz	-11.96	0.06	8.00	Complies
6	2437 MHz	-12.03	0.06	8.00	Complies
11	2462 MHz	-9.92	0.10	8.00	Complies

Temperature	22°C	Humidity	65%
Test Engineer	Serway Li	Configurations	IEEE 802.11b/g / Ant. 1

Configuration IEEE 802.11b / Ant. 1

Channel	Frequency	Power Density (dBm/3kHz)	Power Density (mW/3kHz)	Max. Limit (dBm/3kHz)	Result
1	2412 MHz	-1.70	0.68	8.00	Complies
6	2437 MHz	-2.44	0.57	8.00	Complies
11	2462 MHz	-2.32	0.59	8.00	Complies

Configuration IEEE 802.11g / Ant. 1

Channel	Frequency	Power Density (dBm/3kHz)	Power Density (mW/3kHz)	Max. Limit (dBm/3kHz)	Result
1	2412 MHz	-9.25	0.12	8.00	Complies
6	2437 MHz	-8.69	0.14	8.00	Complies
11	2462 MHz	-9.81	0.10	8.00	Complies

Note: All the test values were listed in the report.

For plots, only the channel with maximum results was shown.

<For Ant. 2>

Temperature	22°C	Humidity	65%
Test Engineer	Serway Li	Configurations	IEEE 802.11n / Ant. 2

Configuration IEEE 802.11n MCS0 20MHz / Ant. 2

Channel	Frequency	Power Density (dBm/3kHz)	Power Density (mW/3kHz)	Max. Limit (dBm/3kHz)	Result
1	2412 MHz	-4.68	0.34	8.00	Complies
6	2437 MHz	-1.04	0.79	8.00	Complies
11	2462 MHz	-5.87	0.26	8.00	Complies

Configuration IEEE 802.11n MCS0 40MHz / Ant. 2

Channel	Frequency	Power Density (dBm/3kHz)	Power Density (mW/3kHz)	Max. Limit (dBm/3kHz)	Result
1	2412 MHz	-9.45	0.11	8.00	Complies
6	2437 MHz	-8.16	0.15	8.00	Complies
11	2462 MHz	-8.46	0.14	8.00	Complies

Temperature	22°C	Humidity	65%
Test Engineer	Serway Li	Configurations	IEEE 802.11b/g / Ant. 2

Configuration IEEE 802.11b / Ant. 2

Channel	Frequency	Power Density (dBm/3kHz)	Power Density (mW/3kHz)	Max. Limit (dBm/3kHz)	Result
1	2412 MHz	-1.12	0.77	8.00	Complies
6	2437 MHz	-1.23	0.75	8.00	Complies
11	2462 MHz	-1.13	0.77	8.00	Complies

Configuration IEEE 802.11g / Ant. 2

Channel	Frequency	Power Density (dBm/3kHz)	Power Density (mW/3kHz)	Max. Limit (dBm/3kHz)	Result
1	2412 MHz	-5.40	0.29	8.00	Complies
6	2437 MHz	-1.50	0.71	8.00	Complies
11	2462 MHz	-4.77	0.33	8.00	Complies

Note: All the test values were listed in the report.

For plots, only the channel with maximum results was shown.

<For Ant. 3>

Temperature	22°C	Humidity	65%
Test Engineer	Serway Li	Configurations	IEEE 802.11n / Ant. 3

Configuration IEEE 802.11n MCS0 20MHz / Ant. 3

Channel	Frequency	Power Density (dBm/3kHz)	Power Density (mW/3kHz)	Max. Limit (dBm/3kHz)	Result
1	2412 MHz	-8.32	0.15	8.00	Complies
6	2437 MHz	-6.80	0.21	8.00	Complies
11	2462 MHz	-7.82	0.17	8.00	Complies

Configuration IEEE 802.11n MCS0 40MHz / Ant. 3

Channel	Frequency	Power Density (dBm/3kHz)	Power Density (mW/3kHz)	Max. Limit (dBm/3kHz)	Result
1	2412 MHz	-13.27	0.05	8.00	Complies
6	2437 MHz	-11.70	0.07	8.00	Complies
11	2462 MHz	-12.03	0.06	8.00	Complies

Temperature	22°C	Humidity	65%
Test Engineer	Serway Li	Configurations	IEEE 802.11b/g / Ant. 3

Configuration IEEE 802.11b / Ant. 3

Channel	Frequency	Power Density (dBm/3kHz)	Power Density (mW/3kHz)	Max. Limit (dBm/3kHz)	Result
1	2412 MHz	-5.88	0.26	8.00	Complies
6	2437 MHz	-5.32	0.29	8.00	Complies
11	2462 MHz	-4.80	0.33	8.00	Complies

Configuration IEEE 802.11g / Ant. 3

Channel	Frequency	Power Density (dBm/3kHz)	Power Density (mW/3kHz)	Max. Limit (dBm/3kHz)	Result
1	2412 MHz	-7.33	0.18	8.00	Complies
6	2437 MHz	-5.17	0.30	8.00	Complies
11	2462 MHz	-7.08	0.20	8.00	Complies

Note: All the test values were listed in the report.

For plots, only the channel with maximum results was shown.

<For Ant. 4>

Temperature	22°C	Humidity	65%
Test Engineer	Allen Liu	Configurations	IEEE 802.11n / Ant. 4

Configuration IEEE 802.11n MCS0 20MHz / Ant. 4

Channel	Frequency	Power Density (dBm/3kHz)	Power Density (mW/3kHz)	Max. Limit (dBm/3kHz)	Result
1	2412 MHz	-4.67	0.34	8.00	Complies
6	2437 MHz	-0.08	0.98	8.00	Complies
11	2462 MHz	-3.45	0.45	8.00	Complies

Configuration IEEE 802.11n MCS0 40MHz / Ant. 4

Channel	Frequency	Power Density (dBm/3kHz)	Power Density (mW/3kHz)	Max. Limit (dBm/3kHz)	Result
1	2412 MHz	-8.96	0.13	8.00	Complies
6	2437 MHz	-7.85	0.16	8.00	Complies
11	2462 MHz	-12.48	0.06	8.00	Complies

Temperature	22°C	Humidity	65%
Test Engineer	Allen Liu	Configurations	IEEE 802.11b/g / Ant. 4

Configuration IEEE 802.11b / Ant. 4

Channel	Frequency	Power Density (dBm/3kHz)	Power Density (mW/3kHz)	Max. Limit (dBm/3kHz)	Result
1	2412 MHz	0.24	1.06	8.00	Complies
6	2437 MHz	2.12	1.63	8.00	Complies
11	2462 MHz	0.11	1.03	8.00	Complies

Configuration IEEE 802.11g / Ant. 4

Channel	Frequency	Power Density (dBm/3kHz)	Power Density (mW/3kHz)	Max. Limit (dBm/3kHz)	Result
1	2412 MHz	-3.62	0.43	8.00	Complies
6	2437 MHz	-0.48	0.90	8.00	Complies
11	2462 MHz	-2.82	0.52	8.00	Complies

Note: All the test values were listed in the report.

For plots, only the channel with maximum results was shown.

<For Ant. 5>

Temperature	23°C	Humidity	63%
Test Engineer	Satoshi Yang	Configurations	IEEE 802.11n / Ant. 5

Configuration IEEE 802.11n MCS0 20MHz / Ant. 5

Channel	Frequency	Power Density (dBm/3kHz)	Max. Limit (dBm/3kHz)	Result
1	2412 MHz	-4.06	8.00	Complies
6	2437 MHz	-4.72	8.00	Complies
11	2462 MHz	-4.16	8.00	Complies

Configuration IEEE 802.11n MCS0 40MHz / Ant. 5

Channel	Frequency	Power Density (dBm/3kHz)	Max. Limit (dBm/3kHz)	Result
1	2412 MHz	-6.78	8.00	Complies
6	2437 MHz	-5.58	8.00	Complies
11	2462 MHz	-7.04	8.00	Complies

Temperature	22°C	Humidity	65%
Test Engineer	Serway Li	Configurations	IEEE 802.11b/g / Ant. 5

Configuration IEEE 802.11b / Ant. 5

Channel	Frequency	Power Density (dBm/3kHz)	Max. Limit (dBm/3kHz)	Result
1	2412 MHz	-3.31	8.00	Complies
6	2437 MHz	-2.42	8.00	Complies
11	2462 MHz	-3.35	8.00	Complies

Configuration IEEE 802.11g / Ant. 5

Channel	Frequency	Power Density (dBm/3kHz)	Max. Limit (dBm/3kHz)	Result
1	2412 MHz	-4.34	8.00	Complies
6	2437 MHz	-2.85	8.00	Complies
11	2462 MHz	-4.89	8.00	Complies

Note: All the test values were listed in the report.

For plots, only the channel with maximum results was shown.

<For Ant. 1>

Power Density Plot on Configuration IEEE 802.11n MCS0 20MHz / Ant. 1 / 2437 MHz

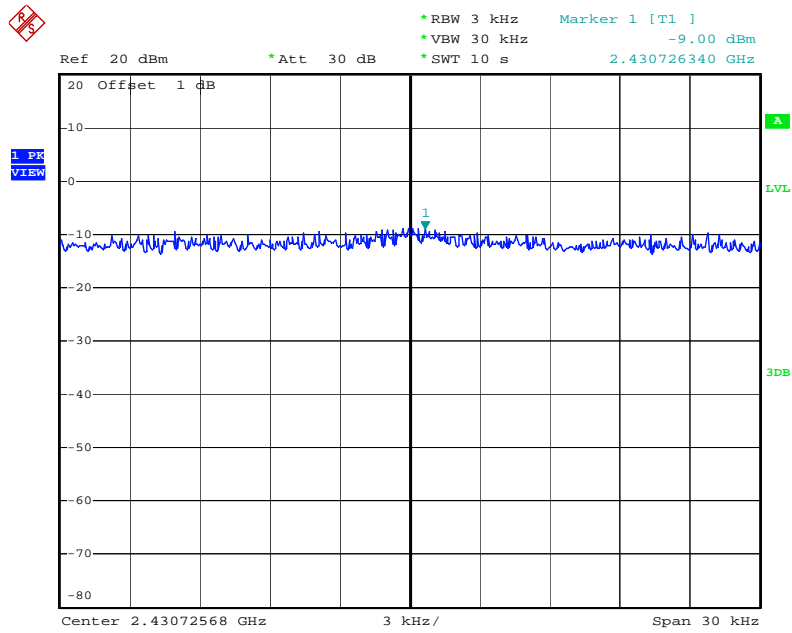

Date: 16.JUN.2011 11:54:05

Power Density Plot on Configuration IEEE 802.11n MCS0 40MHz / Ant. 1 / 2452 MHz

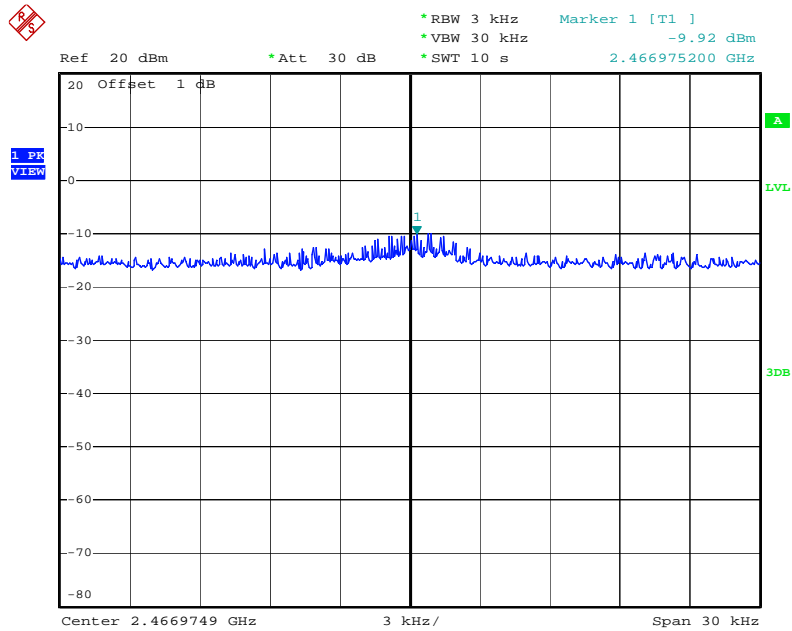

Date: 16.JUN.2011 12:04:20

Power Density Plot on Configuration IEEE 802.11b / Ant. 1 / 2412 MHz

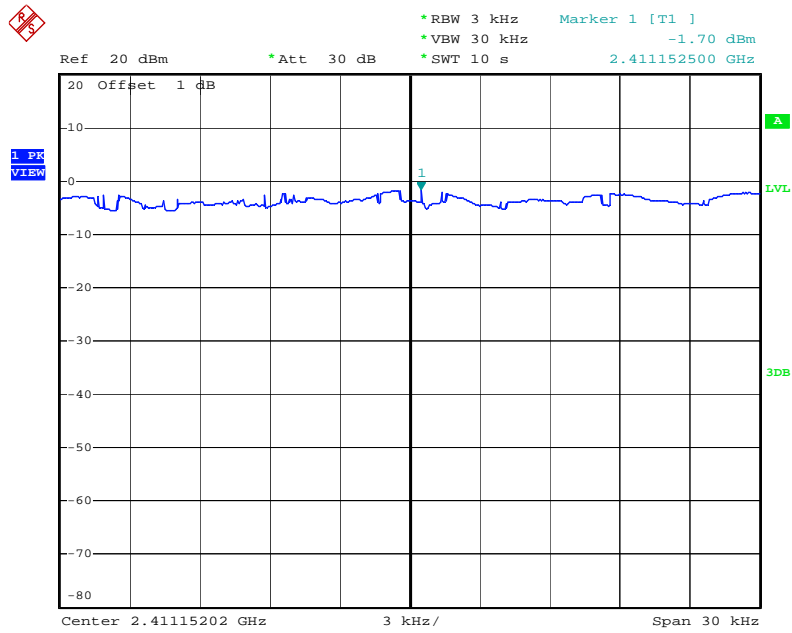

Date: 16.JUN.2011 11:38:03

Power Density Plot on Configuration IEEE 802.11g / Ant. 1 / 2437 MHz

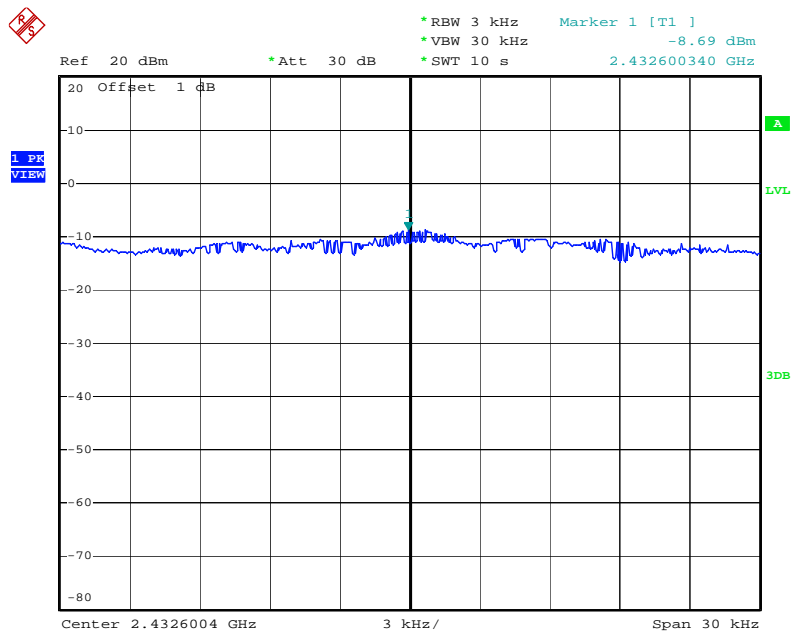

Date: 16.JUN.2011 11:47:16

<For Ant. 2>

Power Density Plot on Configuration IEEE 802.11n MCS0 20MHz / Ant. 2 / 2437 MHz

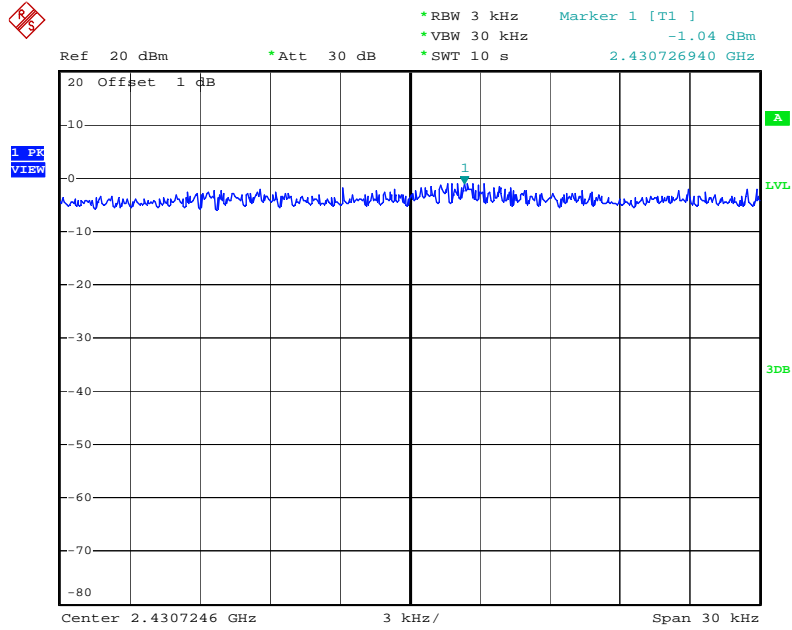

Date: 16.JUN.2011 12:59:04

Power Density Plot on Configuration IEEE 802.11n MCS0 40MHz / Ant. 2 / 2437 MHz

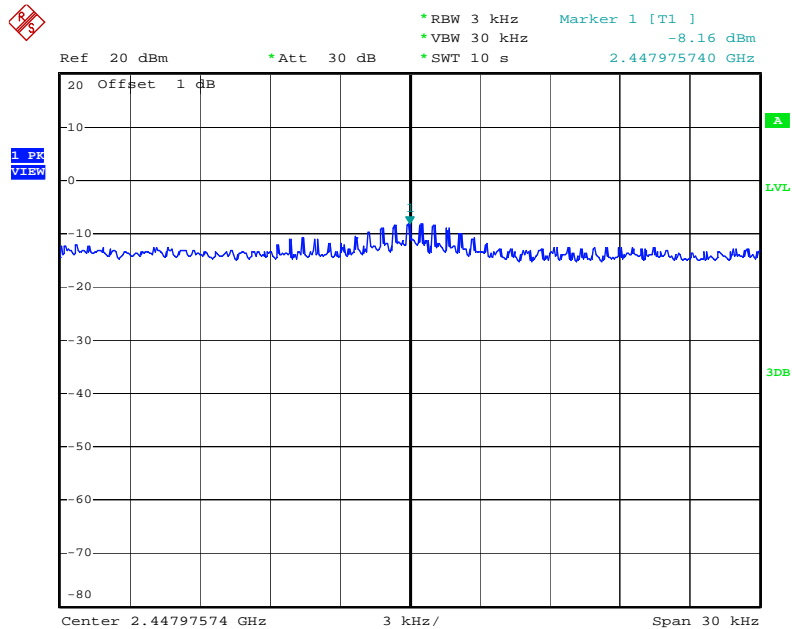

Date: 16.JUN.2011 13:06:33

Power Density Plot on Configuration IEEE 802.11b / Ant. 2 / 2412 MHz

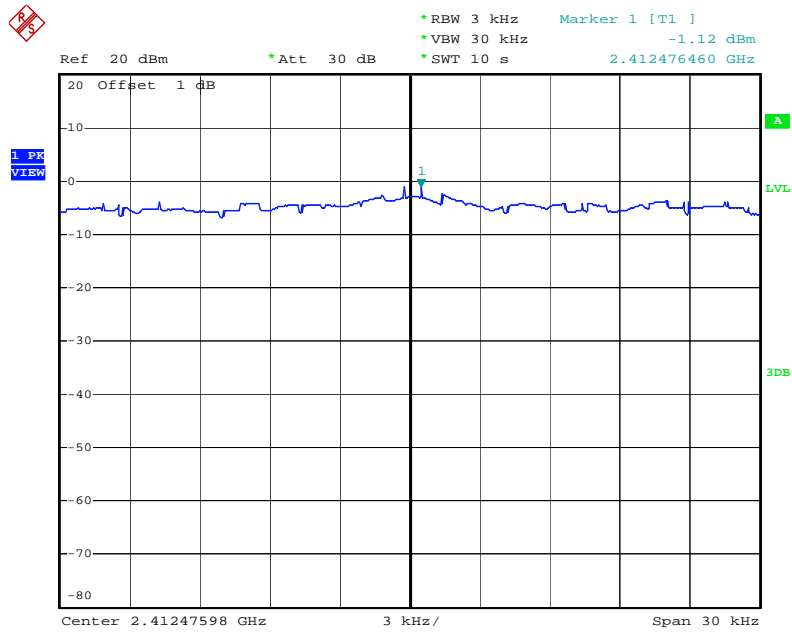

Date: 16.JUN.2011 12:42:32

Power Density Plot on Configuration IEEE 802.11g / Ant. 2 / 2437 MHz

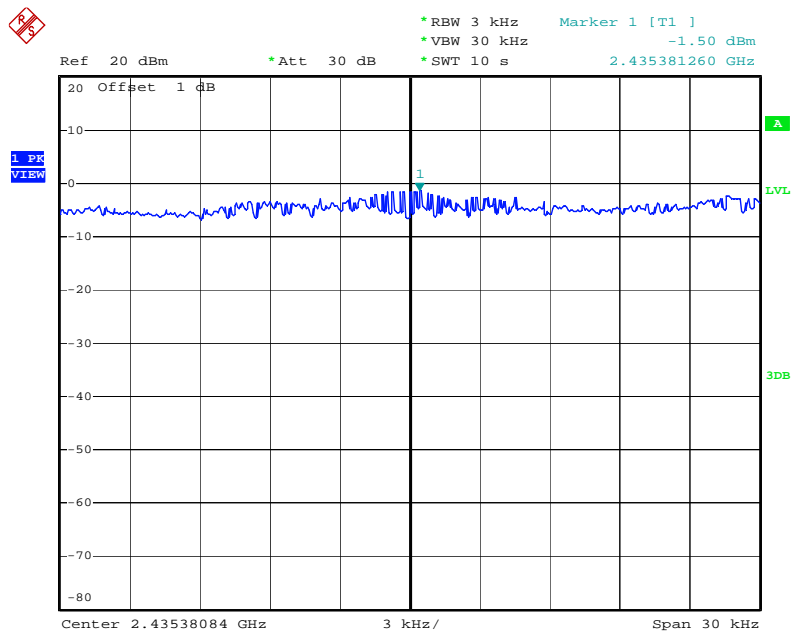

Date: 16.JUN.2011 12:51:50

<For Ant. 3>

Power Density Plot on Configuration IEEE 802.11n MCS0 20MHz / Ant. 3 / 2437 MHz

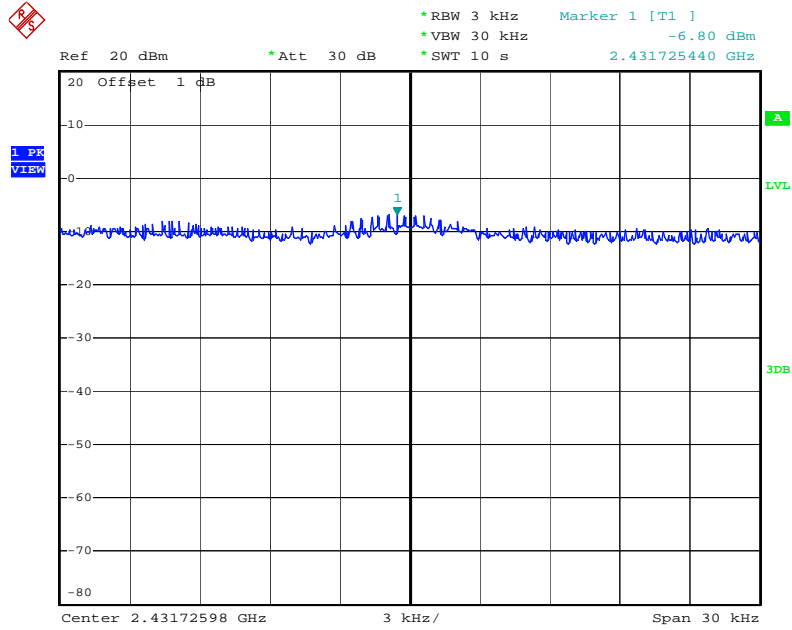

Date: 16.JUN.2011 10:39:05

Power Density Plot on Configuration IEEE 802.11n MCS0 40MHz / Ant. 3 / 2437 MHz

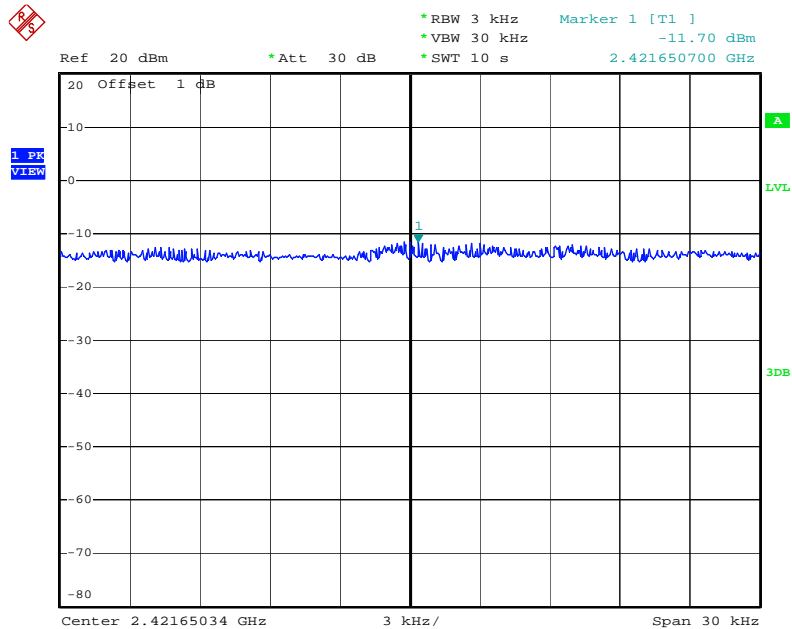

Date: 16.JUN.2011 10:45:55

Power Density Plot on Configuration IEEE 802.11b / Ant. 3 / 2462 MHz

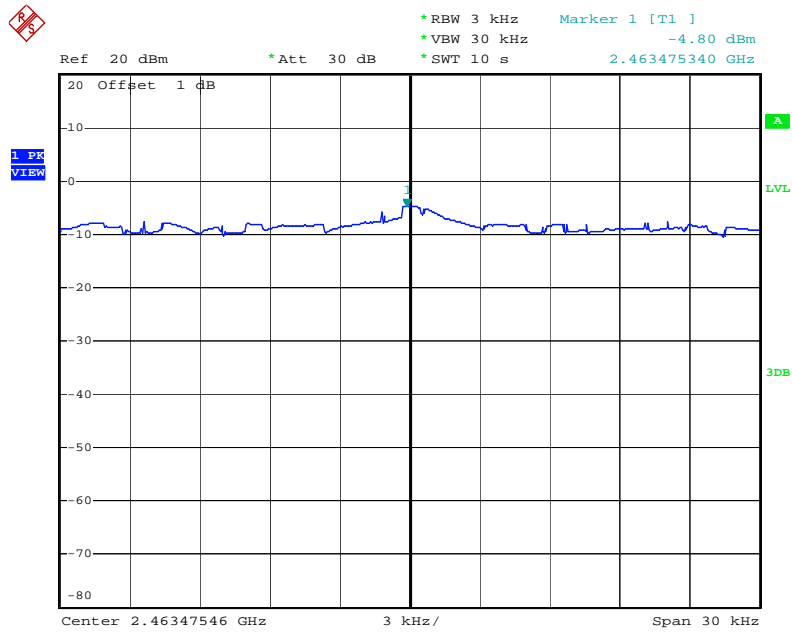

Date: 16.JUN.2011 10:27:04

Power Density Plot on Configuration IEEE 802.11g / Ant. 3 / 2437 MHz

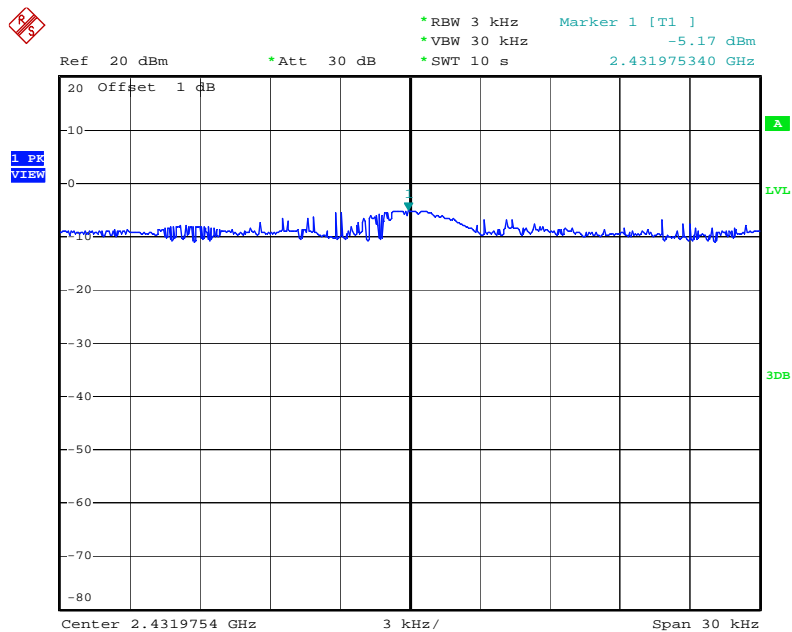

Date: 16.JUN.2011 10:31:49

<For Ant. 4>

Power Density Plot on Configuration IEEE 802.11n MCS0 20MHz / Ant. 4 / 2437 MHz

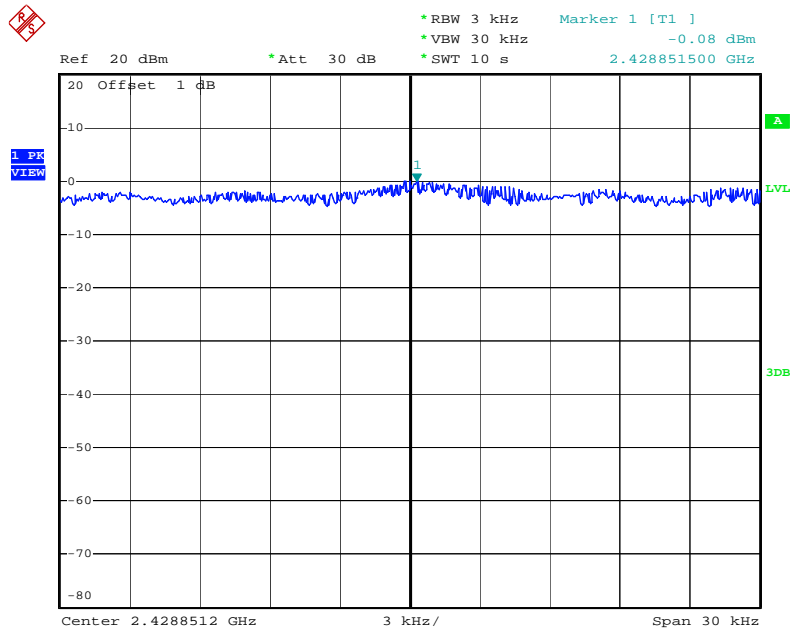

Date: 16.JUN.2011 12:27:57

Power Density Plot on Configuration IEEE 802.11n MCS0 40MHz / Ant. 4 / 2437 MHz

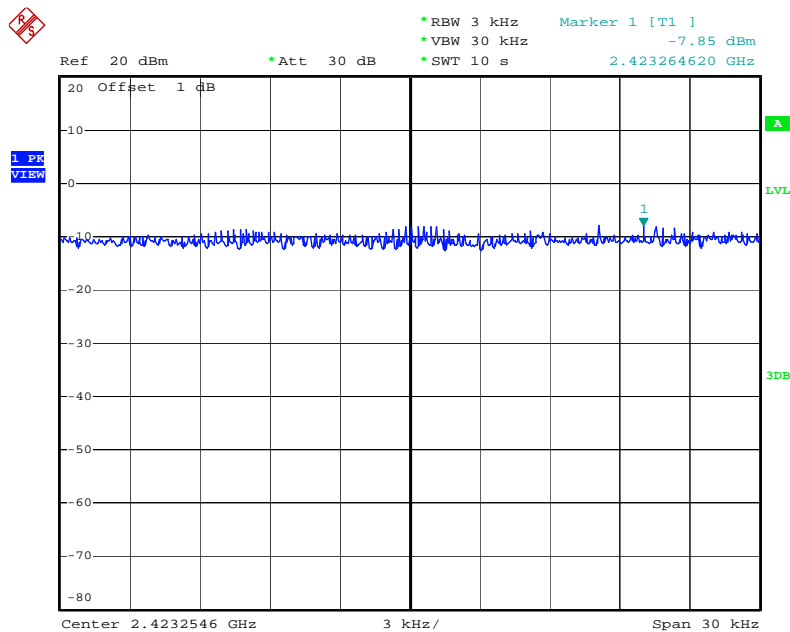

Date: 16.JUN.2011 12:34:53

Power Density Plot on Configuration IEEE 802.11b / Ant. 4 / 2437 MHz

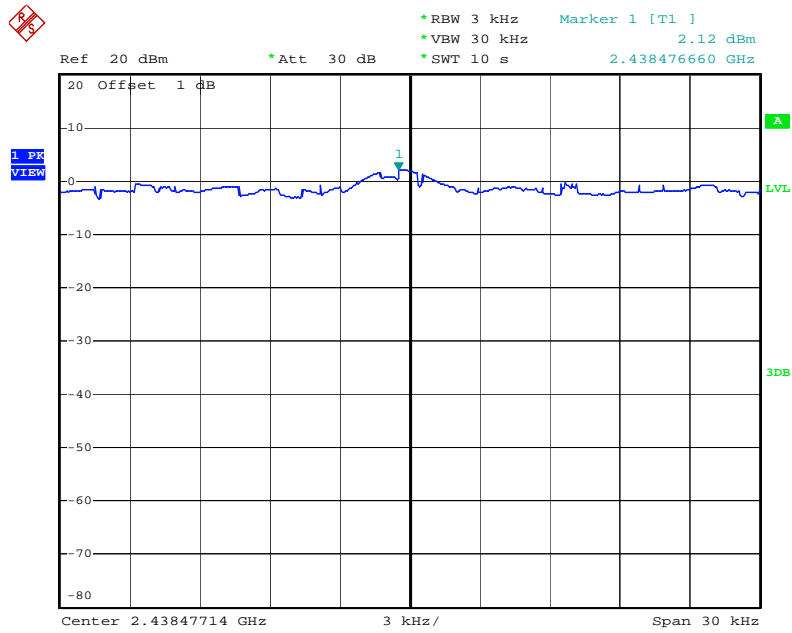

Date: 16.JUN.2011 12:12:59

Power Density Plot on Configuration IEEE 802.11g / Ant. 4 / 2437 MHz

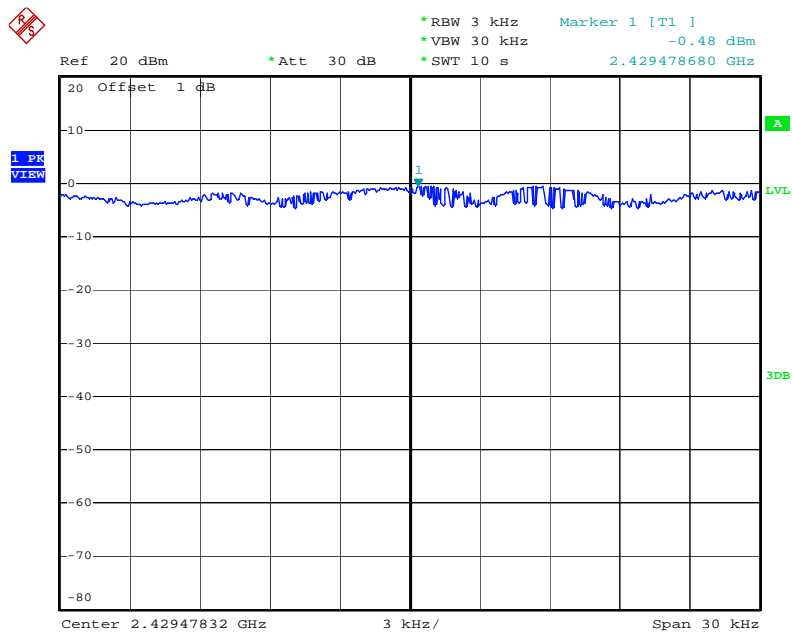

Date: 16.JUN.2011 12:21:10

<For Ant. 5>

Power Density Plot on Configuration IEEE 802.11n MCS0 20MHz / Ant. 5 / 2412 MHz

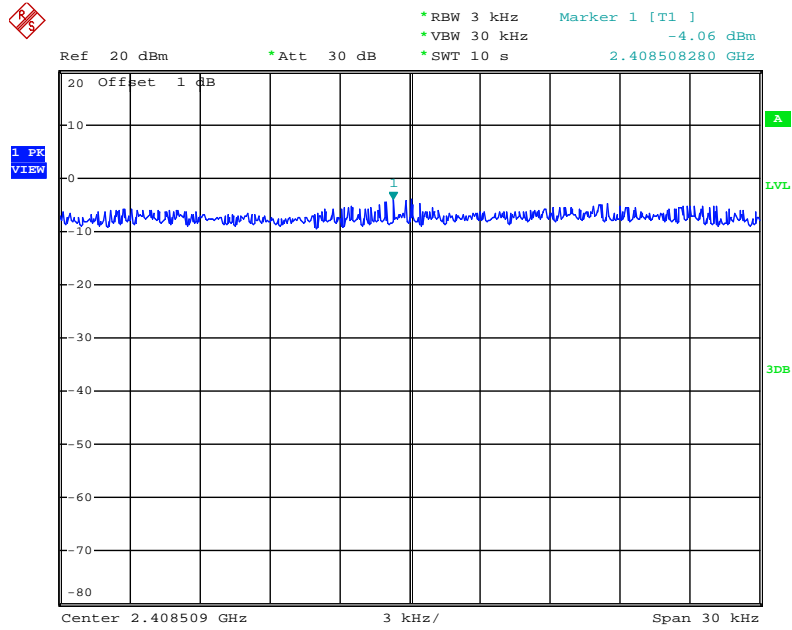

Date: 1.AUG.2011 22:11:55

Power Density Plot on Configuration IEEE 802.11n MCS0 40MHz / Ant. 5 / 2437 MHz

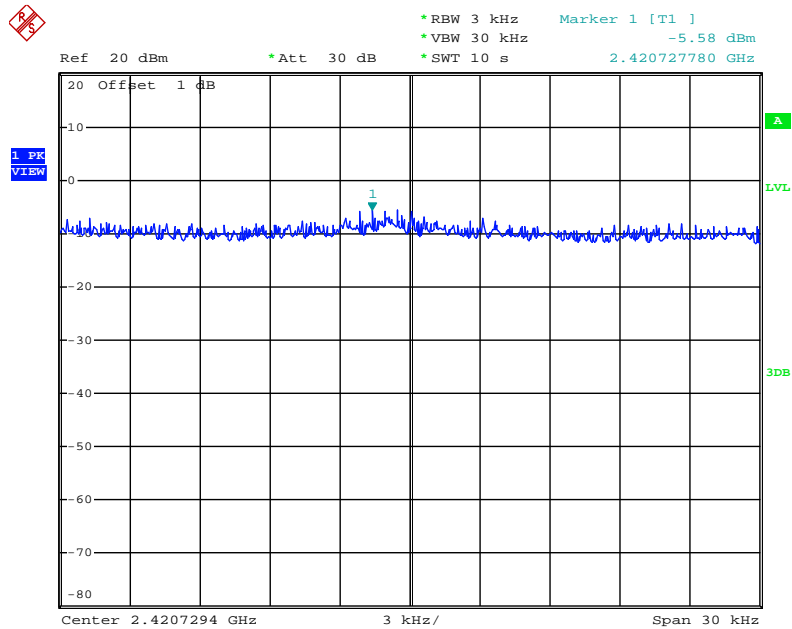

Date: 1.AUG.2011 22:19:57

Power Density Plot on Configuration IEEE 802.11b / Ant. 5 / 2437 MHz

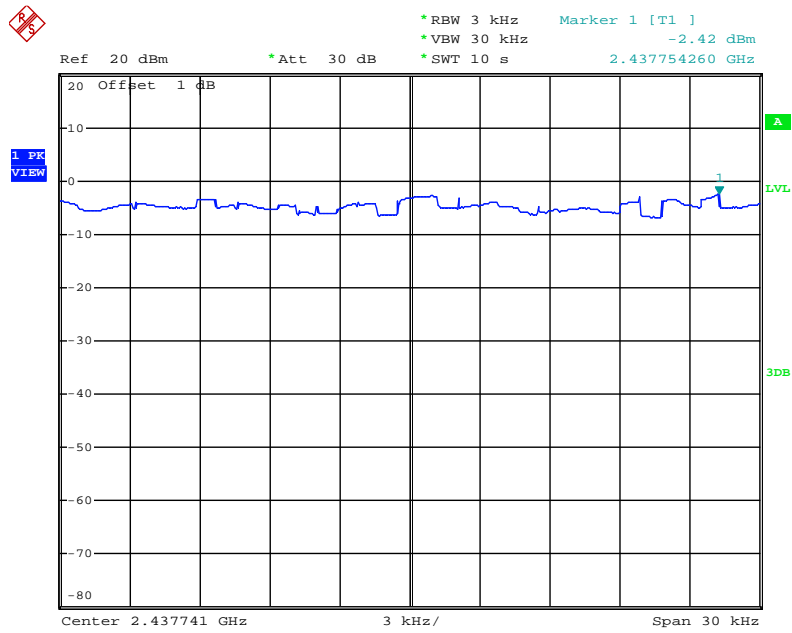

Date: 1.AUG.2011 22:00:49

Power Density Plot on Configuration IEEE 802.11g / Ant. 5 / 2437 MHz

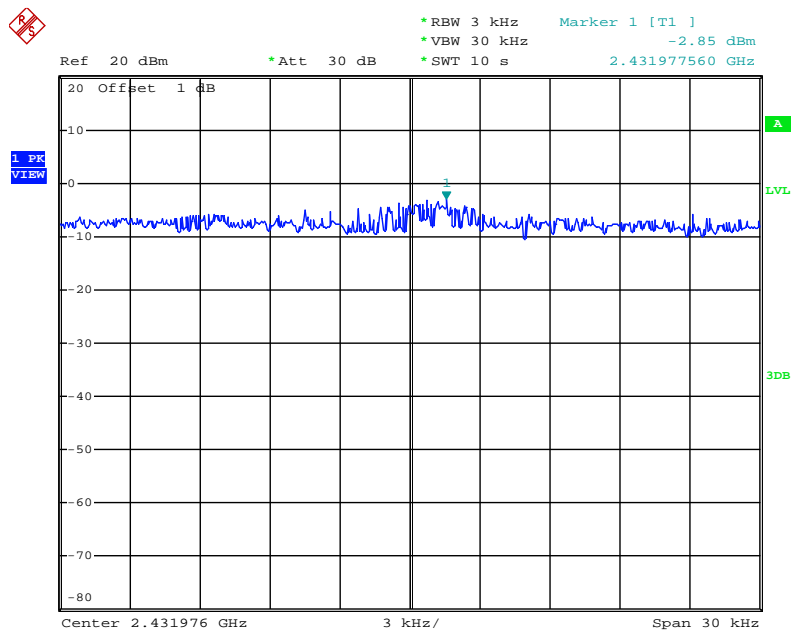

Date: 1.AUG.2011 22:06:40

4.4. 6dB Spectrum Bandwidth Measurement

4.4.1. Limit

For digital modulation systems, the minimum 6 dB bandwidth shall be at least 500 kHz.

4.4.2. Measuring Instruments and Setting

Please refer to section 5 of equipments list in this report. The following table is the setting of the Spectrum Analyzer.

Spectrum Parameters	Setting
Attenuation	Auto
Span Frequency	> 6dB Bandwidth
RB	100 kHz
VB	100 kHz
Detector	Peak
Trace	Max Hold
Sweep Time	Auto

4.4.3. Test Procedures

1. The transmitter output (antenna port) was connected to the spectrum analyzer in peak hold mode.
2. The resolution bandwidth of 100 kHz and the video bandwidth of 100 kHz were used.
3. Measured the spectrum width with power higher than 6dB below carrier.

4.4.4. Test Setup Layout

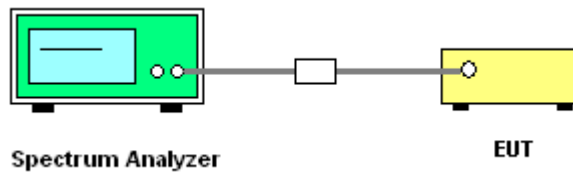

4.4.5. Test Deviation

There is no deviation with the original standard.

4.4.6. EUT Operation during Test

The EUT was programmed to be in continuously transmitting mode.

4.4.7. Test Result of 6dB Spectrum Bandwidth

<For Ant. 1 >

Temperature	22°C	Humidity	65%
Test Engineer	Serway Li	Configurations	IEEE 802.11n / Ant. 1

Configuration IEEE 802.11n MCS0 20MHz / Ant. 1

Channel	Frequency	6dB Bandwidth (MHz)	99% Occupied Bandwidth (MHz)	Min. Limit (kHz)	Test Result
1	2412 MHz	17.56	17.64	500	Complies
6	2437 MHz	17.60	17.76	500	Complies
11	2462 MHz	16.36	17.68	500	Complies

Configuration IEEE 802.11n MCS0 40MHz / Ant. 1

Channel	Frequency	6dB Bandwidth (MHz)	99% Occupied Bandwidth (MHz)	Min. Limit (kHz)	Test Result
3	2422 MHz	35.68	36.08	500	Complies
6	2437 MHz	36.32	36.24	500	Complies
9	2452 MHz	35.68	36.32	500	Complies

Temperature	22°C	Humidity	65%
Test Engineer	Serway Li	Configurations	IEEE 802.11b/g / Ant. 1

Configuration IEEE 802.11b / Ant. 1

Channel	Frequency	6dB Bandwidth (MHz)	99% Occupied Bandwidth (MHz)	Min. Limit (kHz)	Test Result
1	2412 MHz	12.04	15.28	500	Complies
6	2437 MHz	12.60	15.72	500	Complies
11	2462 MHz	11.60	15.56	500	Complies

Configuration IEEE 802.11g / Ant. 1

Channel	Frequency	6dB Bandwidth (MHz)	99% Occupied Bandwidth (MHz)	Min. Limit (kHz)	Test Result
1	2412 MHz	16.36	16.48	500	Complies
6	2437 MHz	16.36	16.56	500	Complies
11	2462 MHz	15.76	16.48	500	Complies

Note: All the test values were listed in the report.

For plots, only the channel with maximum results was shown.

<For Ant. 2>

Temperature	22°C	Humidity	65%
Test Engineer	Serway Li	Configurations	IEEE 802.11n / Ant. 2

Configuration IEEE 802.11n MCS0 20MHz / Ant. 2

Channel	Frequency	6dB Bandwidth (MHz)	99% Occupied Bandwidth (MHz)	Min. Limit (kHz)	Test Result
1	2412 MHz	17.56	17.64	500	Complies
6	2437 MHz	17.60	17.76	500	Complies
11	2462 MHz	16.40	17.68	500	Complies

Configuration IEEE 802.11n MCS0 40MHz / Ant. 2

Channel	Frequency	6dB Bandwidth (MHz)	99% Occupied Bandwidth (MHz)	Min. Limit (kHz)	Test Result
3	2422 MHz	35.76	36.08	500	Complies
6	2437 MHz	36.08	36.24	500	Complies
9	2452 MHz	35.76	36.32	500	Complies

Temperature	22°C	Humidity	65%
Test Engineer	Serway Li	Configurations	IEEE 802.11b/g / Ant. 2

Configuration IEEE 802.11b / Ant. 2

Channel	Frequency	6dB Bandwidth (MHz)	99% Occupied Bandwidth (MHz)	Min. Limit (kHz)	Test Result
1	2412 MHz	12.04	15.20	500	Complies
6	2437 MHz	12.56	15.76	500	Complies
11	2462 MHz	11.56	15.52	500	Complies

Configuration IEEE 802.11g / Ant. 2

Channel	Frequency	6dB Bandwidth (MHz)	99% Occupied Bandwidth (MHz)	Min. Limit (kHz)	Test Result
1	2412 MHz	16.36	16.48	500	Complies
6	2437 MHz	16.36	16.56	500	Complies
11	2462 MHz	15.72	16.52	500	Complies

Note: All the test values were listed in the report.

For plots, only the channel with maximum results was shown.

<For Ant. 3>

Temperature	22°C	Humidity	65%
Test Engineer	Serway Li	Configurations	IEEE 802.11n / Ant. 3

Configuration IEEE 802.11n MCS0 20MHz / Ant. 3

Channel	Frequency	6dB Bandwidth (MHz)	99% Occupied Bandwidth (MHz)	Min. Limit (kHz)	Test Result
1	2412 MHz	17.56	17.64	500	Complies
6	2437 MHz	17.64	17.76	500	Complies
11	2462 MHz	16.40	17.72	500	Complies

Configuration IEEE 802.11n MCS0 40MHz / Ant. 3

Channel	Frequency	6dB Bandwidth (MHz)	99% Occupied Bandwidth (MHz)	Min. Limit (kHz)	Test Result
3	2422 MHz	35.68	36.08	500	Complies
6	2437 MHz	35.92	36.24	500	Complies
9	2452 MHz	35.68	36.32	500	Complies

Temperature	22°C	Humidity	65%
Test Engineer	Serway Li	Configurations	IEEE 802.11b/g / Ant. 3

Configuration IEEE 802.11b / Ant. 3

Channel	Frequency	6dB Bandwidth (MHz)	99% Occupied Bandwidth (MHz)	Min. Limit (kHz)	Test Result
1	2412 MHz	12.04	15.28	500	Complies
6	2437 MHz	12.04	15.72	500	Complies
11	2462 MHz	11.56	15.56	500	Complies

Configuration IEEE 802.11g / Ant. 3

Channel	Frequency	6dB Bandwidth (MHz)	99% Occupied Bandwidth (MHz)	Min. Limit (kHz)	Test Result
1	2412 MHz	16.36	16.48	500	Complies
6	2437 MHz	16.36	16.56	500	Complies
11	2462 MHz	15.76	16.52	500	Complies

Note: All the test values were listed in the report.

For plots, only the channel with maximum results was shown.

<For Ant. 4>

Temperature	22°C	Humidity	65%
Test Engineer	Serway Li	Configurations	IEEE 802.11n / Ant. 4

Configuration IEEE 802.11n MCS0 20MHz / Ant. 4

Channel	Frequency	6dB Bandwidth (MHz)	99% Occupied Bandwidth (MHz)	Min. Limit (kHz)	Test Result
1	2412 MHz	17.60	17.64	500	Complies
6	2437 MHz	17.60	17.76	500	Complies
11	2462 MHz	16.36	17.72	500	Complies

Configuration IEEE 802.11n MCS0 40MHz / Ant. 4

Channel	Frequency	6dB Bandwidth (MHz)	99% Occupied Bandwidth (MHz)	Min. Limit (kHz)	Test Result
3	2422 MHz	35.76	36.08	500	Complies
6	2437 MHz	36.40	36.24	500	Complies
9	2452 MHz	35.76	36.32	500	Complies

Temperature	22°C	Humidity	65%
Test Engineer	Serway Li	Configurations	IEEE 802.11b/g / Ant. 4

Configuration IEEE 802.11b / Ant. 4

Channel	Frequency	6dB Bandwidth (MHz)	99% Occupied Bandwidth (MHz)	Min. Limit (kHz)	Test Result
1	2412 MHz	11.08	15.24	500	Complies
6	2437 MHz	12.56	15.68	500	Complies
11	2462 MHz	11.52	15.52	500	Complies

Configuration IEEE 802.11g / Ant. 4

Channel	Frequency	6dB Bandwidth (MHz)	99% Occupied Bandwidth (MHz)	Min. Limit (kHz)	Test Result
1	2412 MHz	16.36	16.48	500	Complies
6	2437 MHz	16.36	16.56	500	Complies
11	2462 MHz	15.64	16.52	500	Complies

Note: All the test values were listed in the report.

For plots, only the channel with maximum results was shown.

<For Ant. 5>

Temperature	23°C	Humidity	63%
Test Engineer	Satoshi Yang	Configurations	IEEE 802.11n / Ant. 5

Configuration IEEE 802.11n MCS0 20MHz / Ant. 5

Channel	Frequency	6dB Bandwidth (MHz)	99% Occupied Bandwidth (MHz)	Min. Limit (kHz)	Test Result
1	2412 MHz	15.72	17.68	500	Complies
6	2437 MHz	17.60	17.72	500	Complies
11	2462 MHz	14.44	16.48	500	Complies

Configuration IEEE 802.11n MCS0 40MHz / Ant. 5

Channel	Frequency	6dB Bandwidth (MHz)	99% Occupied Bandwidth (MHz)	Min. Limit (kHz)	Test Result
3	2422 MHz	35.68	36.16	500	Complies
6	2437 MHz	36.40	36.40	500	Complies
9	2452 MHz	34.56	36.32	500	Complies

Temperature	23°C	Humidity	63%
Test Engineer	Satoshi Yang	Configurations	IEEE 802.11b/g / Ant. 5

Configuration IEEE 802.11b / Ant. 5

Channel	Frequency	6dB Bandwidth (MHz)	99% Occupied Bandwidth (MHz)	Min. Limit (kHz)	Test Result
1	2412 MHz	12.08	15.36	500	Complies
6	2437 MHz	11.08	15.76	500	Complies
11	2462 MHz	11.12	15.48	500	Complies

Configuration IEEE 802.11g / Ant. 5

Channel	Frequency	6dB Bandwidth (MHz)	99% Occupied Bandwidth (MHz)	Min. Limit (kHz)	Test Result
1	2412 MHz	16.32	16.48	500	Complies
6	2437 MHz	16.36	16.56	500	Complies
11	2462 MHz	15.76	16.48	500	Complies

Note: All the test values were listed in the report.

For plots, only the channel with maximum results was shown.

<For Ant. 1>

6 dB Bandwidth Plot on Configuration IEEE 802.11n MCS0 20MHz / Ant. 1 / 2462 MHz

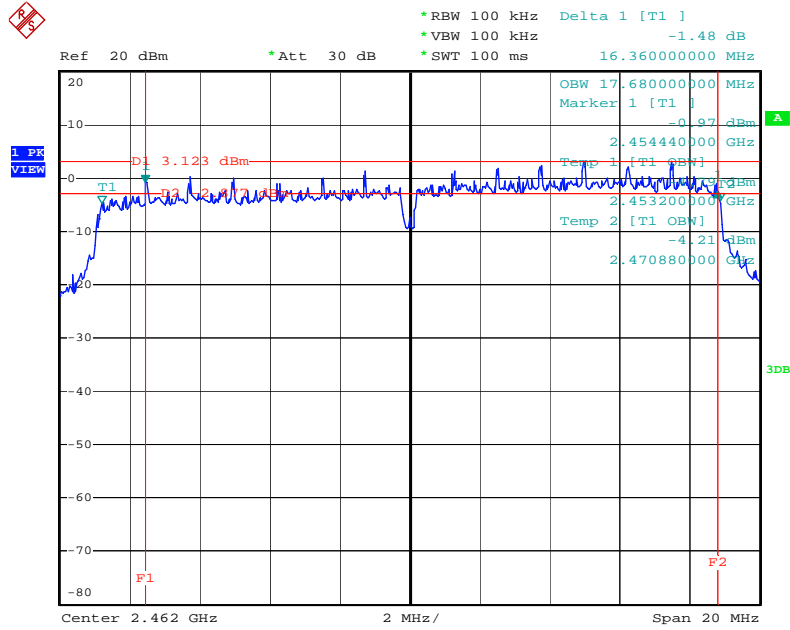

Date: 16.JUN.2011 11:55:31

6 dB Bandwidth Plot on Configuration IEEE 802.11n MCS0 40MHz / Ant. 1 / 2452 MHz

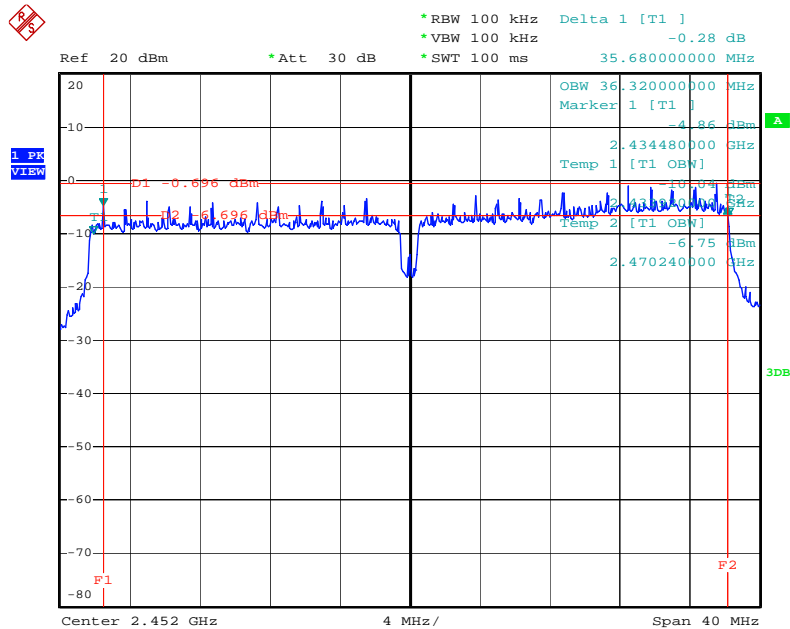

Date: 16.JUN.2011 12:02:50

6 dB Bandwidth Plot on Configuration IEEE 802.11b / Ant. 1 / 2462 MHz

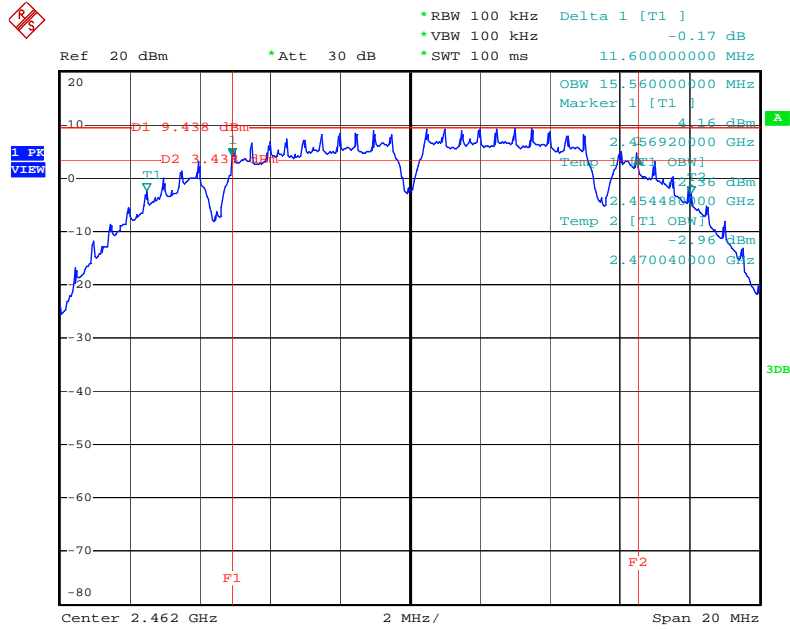

Date: 16.JUN.2011 11:41:05

6 dB Bandwidth Plot on Configuration IEEE 802.11g / Ant. 1 / 2462 MHz

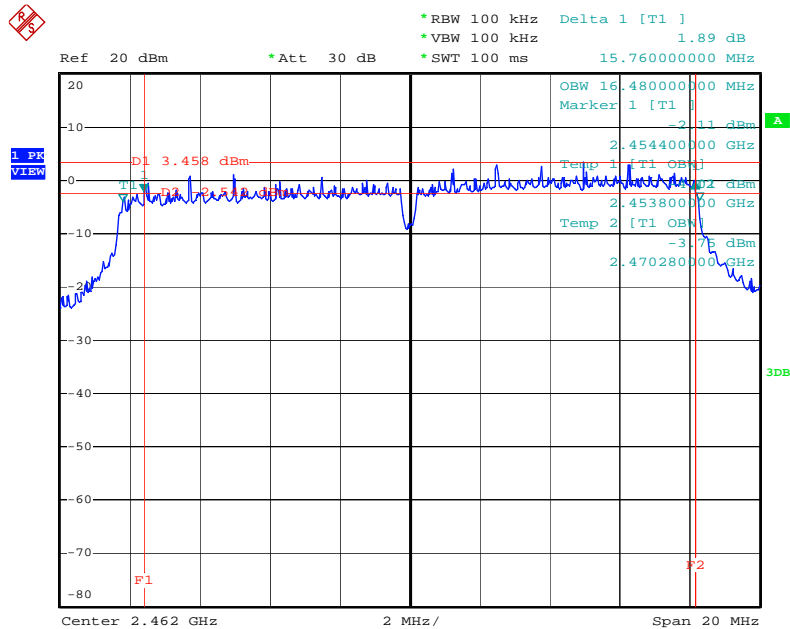

Date: 16.JUN.2011 11:47:54

<For Ant. 2>

6 dB Bandwidth Plot on Configuration IEEE 802.11n MCS0 20MHz / Ant. 2 / 2462 MHz

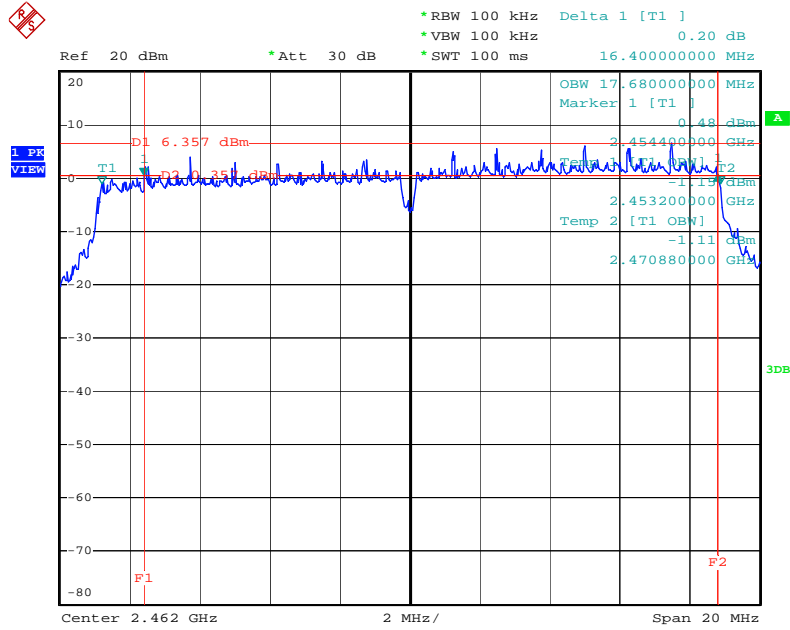

Date: 16.JUN.2011 12:59:38

6 dB Bandwidth Plot on Configuration IEEE 802.11n MCS0 40MHz / Ant. 2 / 2452 MHz

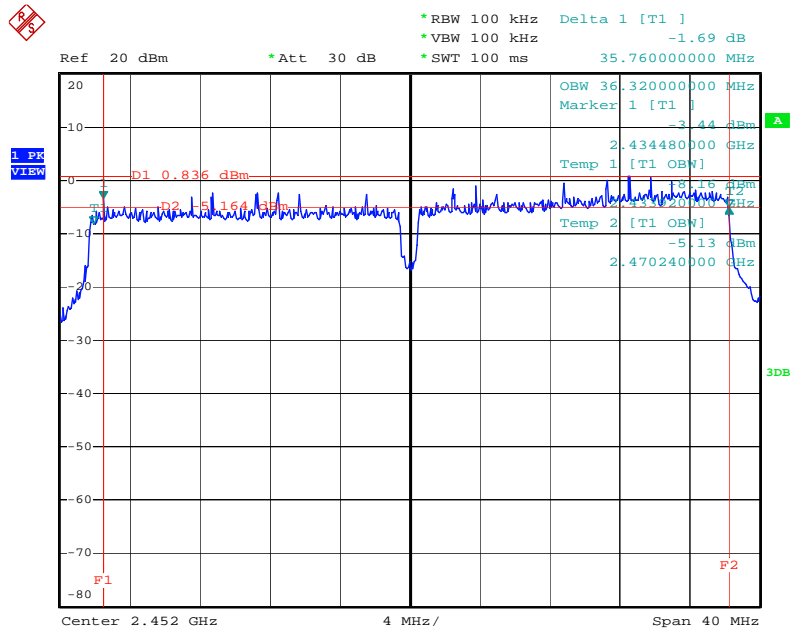

Date: 16.JUN.2011 13:07:12

6 dB Bandwidth Plot on Configuration IEEE 802.11b / Ant. 2 / 2462 MHz

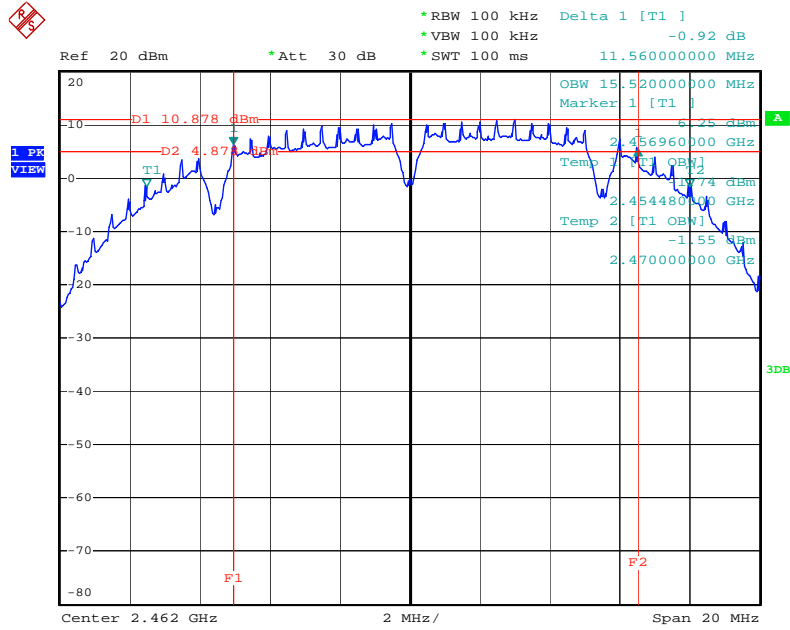

Date: 16.JUN.2011 12:45:40

6 dB Bandwidth Plot on Configuration IEEE 802.11g / Ant. 2 / 2462 MHz

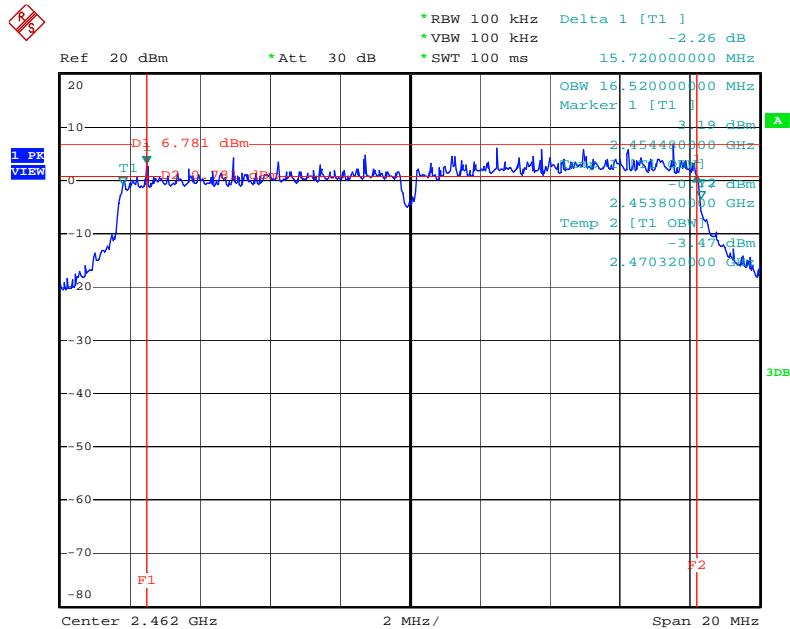

Date: 16.JUN.2011 12:52:36

<For Ant. 3>

6 dB Bandwidth Plot on Configuration IEEE 802.11n MCS0 20MHz / Ant. 3 / 2462 MHz

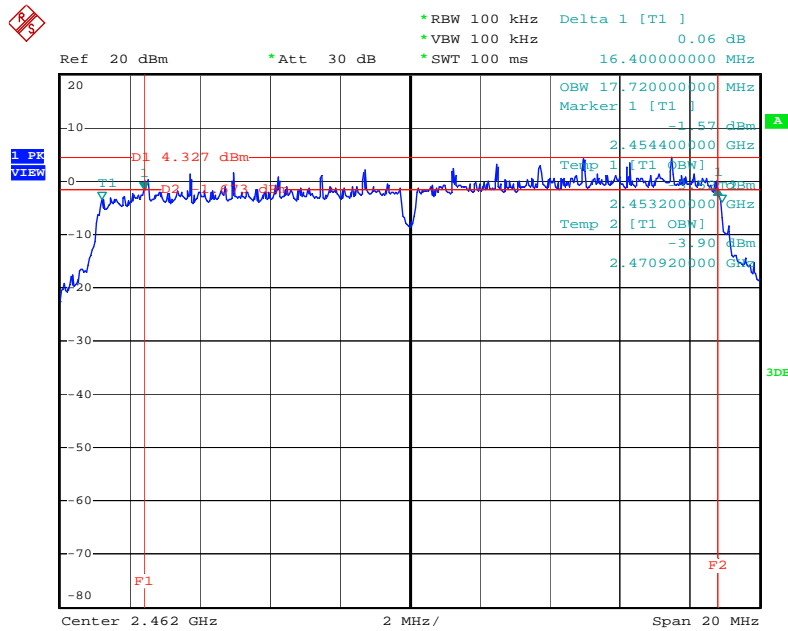

Date: 16.JUN.2011 10:39:36

6 dB Bandwidth Plot on Configuration IEEE 802.11n MCS0 40MHz / Ant. 3 / 2452 MHz

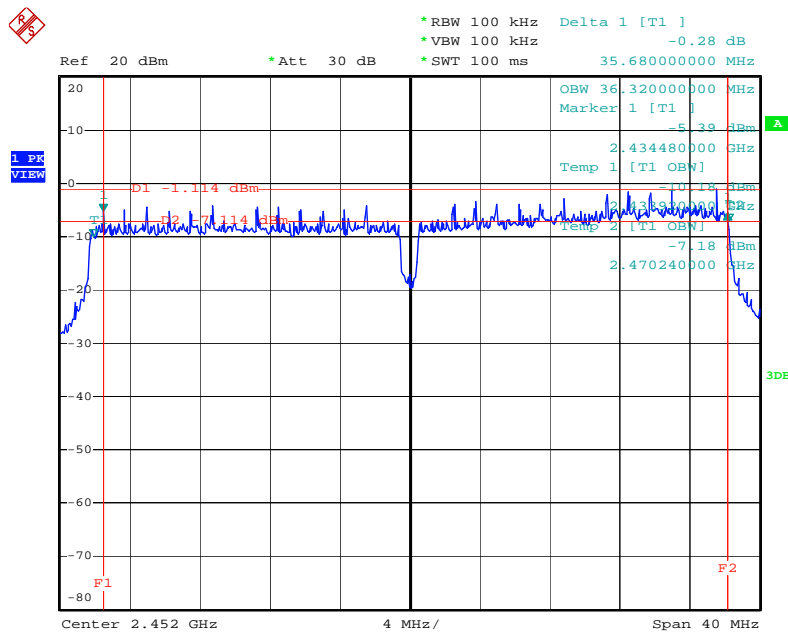

Date: 16.JUN.2011 10:42:10

6 dB Bandwidth Plot on Configuration IEEE 802.11b / Ant. 3 / 2462 MHz

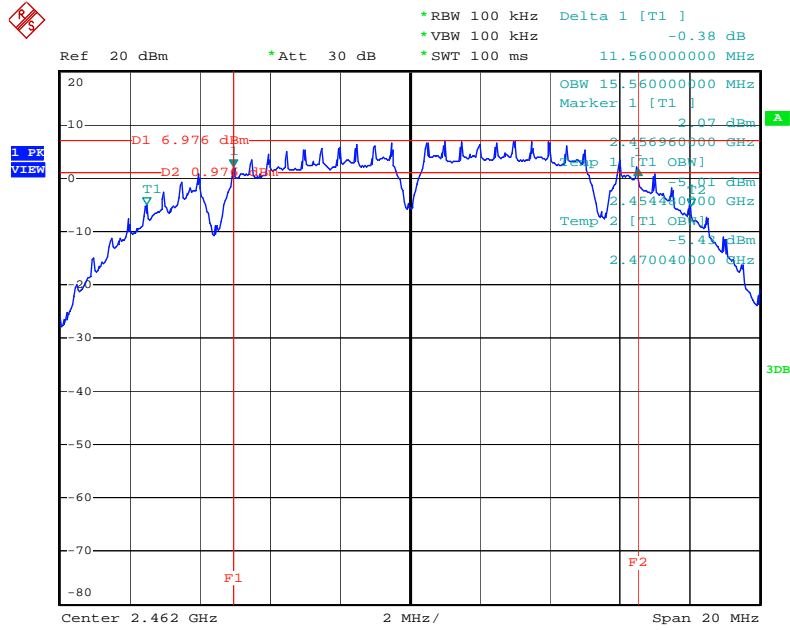

Date: 16.JUN.2011 10:25:34

6 dB Bandwidth Plot on Configuration IEEE 802.11g / Ant. 3 / 2462 MHz

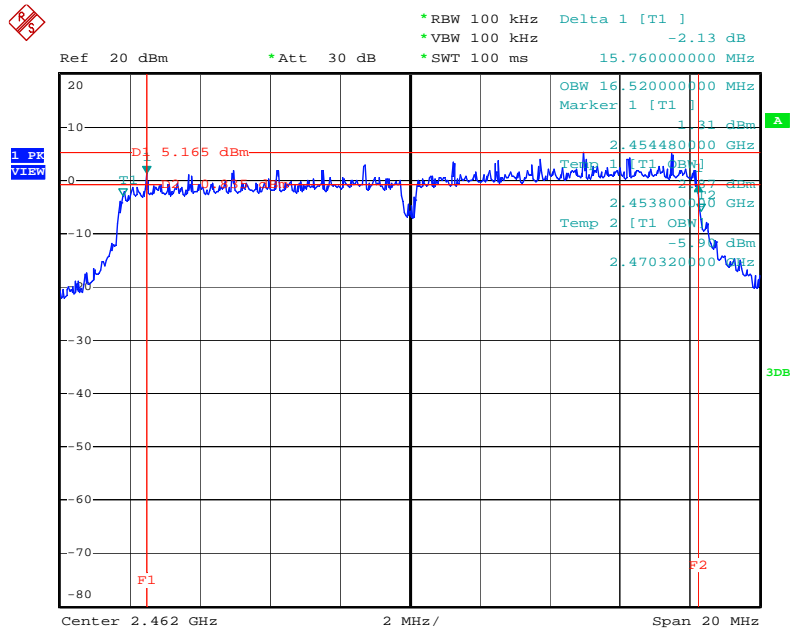

Date: 16.JUN.2011 10:27:49

<For Ant. 4>

6 dB Bandwidth Plot on Configuration IEEE 802.11n MCS0 20MHz / Ant. 4 / 2462 MHz

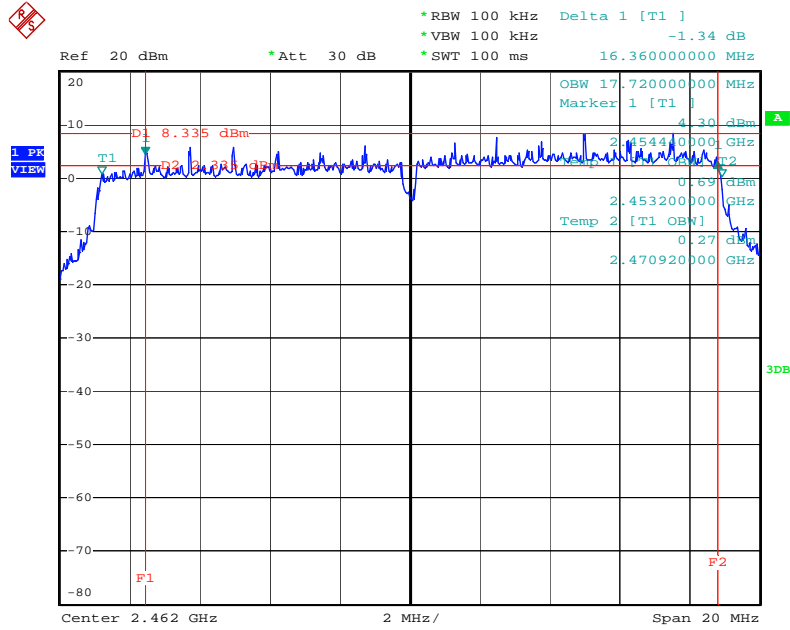

Date: 16.JUN.2011 12:28:32

6 dB Bandwidth Plot on Configuration IEEE 802.11n MCS0 40MHz / Ant. 4 / 2452 MHz

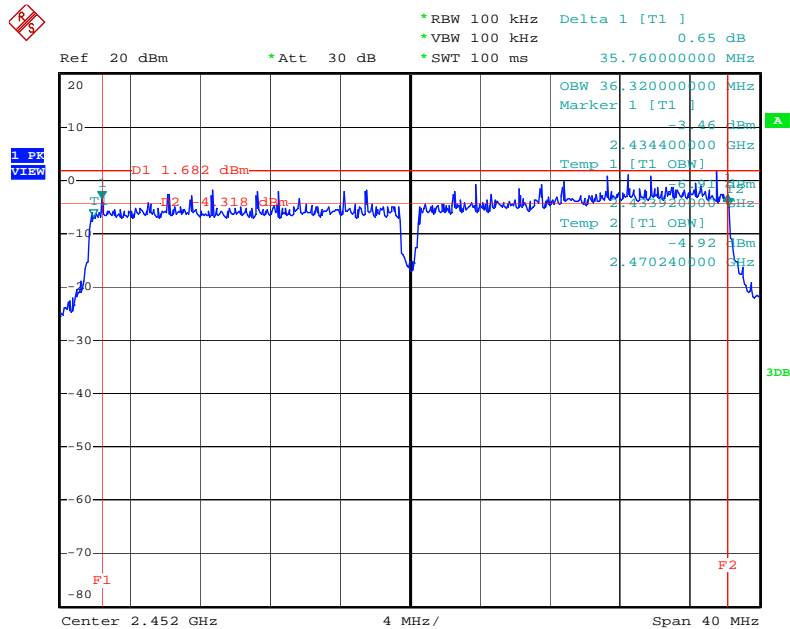

Date: 16.JUN.2011 12:35:31

6 dB Bandwidth Plot on Configuration IEEE 802.11b / Ant. 4 / 2412 MHz

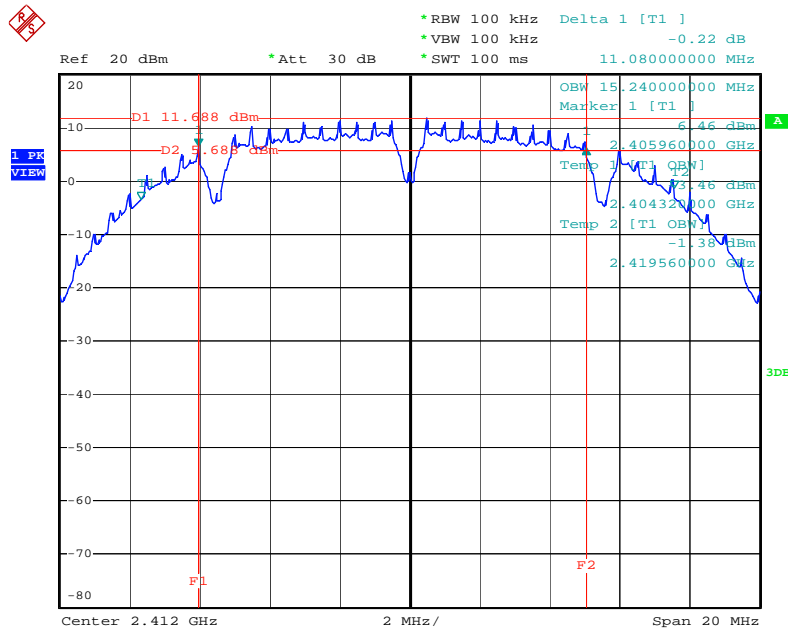

Date: 16.JUN.2011 12:09:05

6 dB Bandwidth Plot on Configuration IEEE 802.11g / Ant. 4 / 2462 MHz

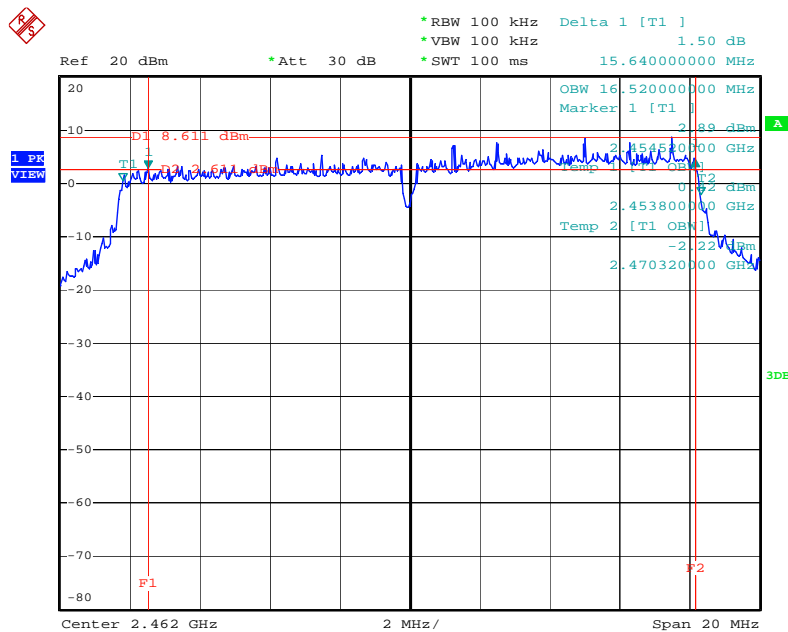

Date: 16.JUN.2011 12:21:45

<For Ant. 5>

6 dB Bandwidth Plot on Configuration IEEE 802.11n MCS0 20MHz / Ant. 5 / 2462 MHz

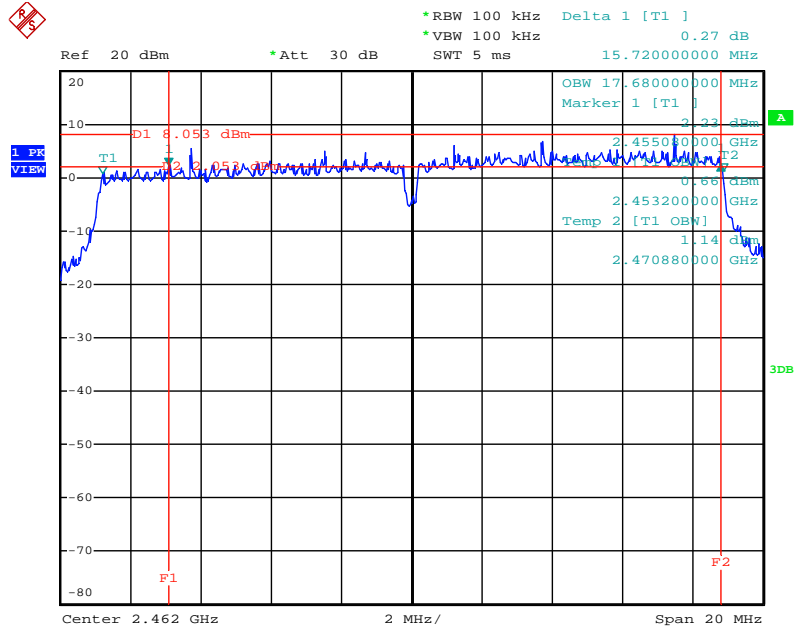

Date: 1.AUG.2011 21:44:04

6 dB Bandwidth Plot on Configuration IEEE 802.11n MCS0 40MHz / Ant. 5 / 2452 MHz

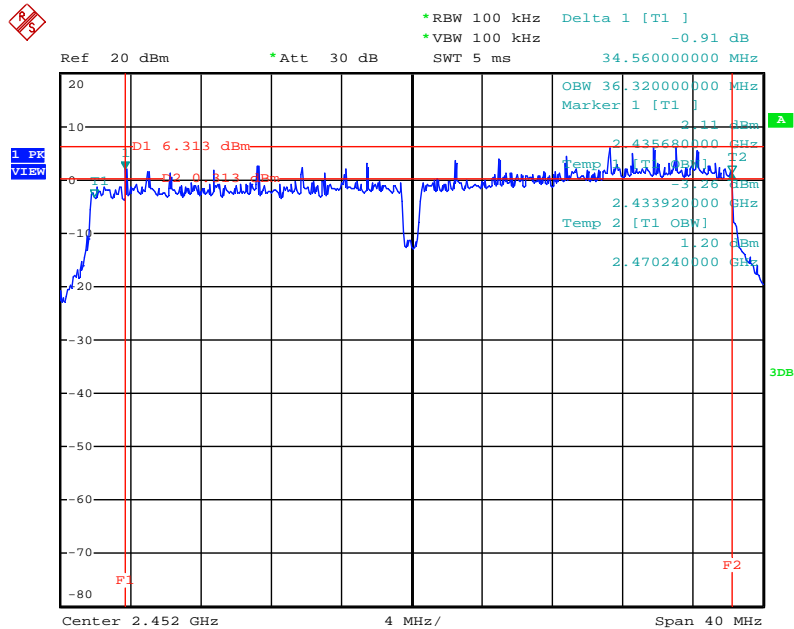

Date: 1.AUG.2011 21:42:21

6 dB Bandwidth Plot on Configuration IEEE 802.11b / Ant. 5 / 2437 MHz

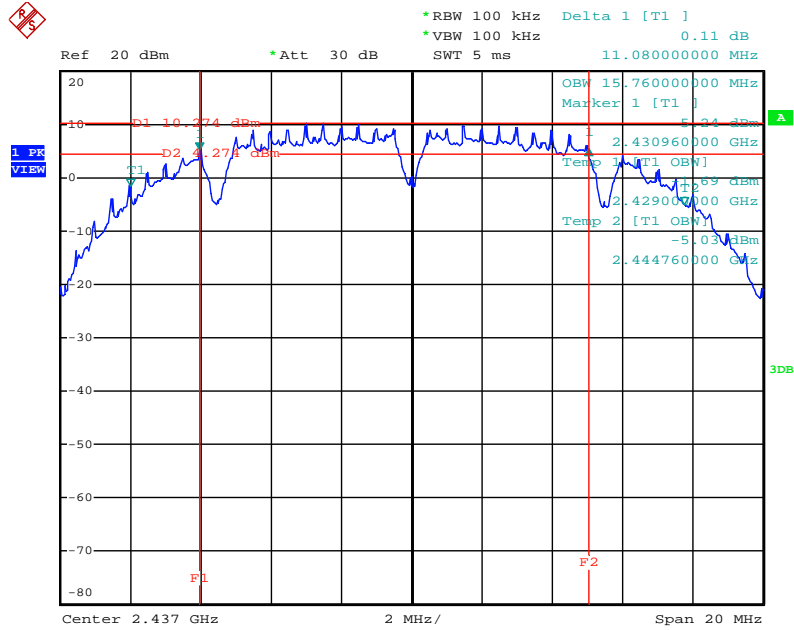

Date: 1.AUG.2011 21:55:19

6 dB Bandwidth Plot on Configuration IEEE 802.11g / Ant. 5 / 2412 MHz

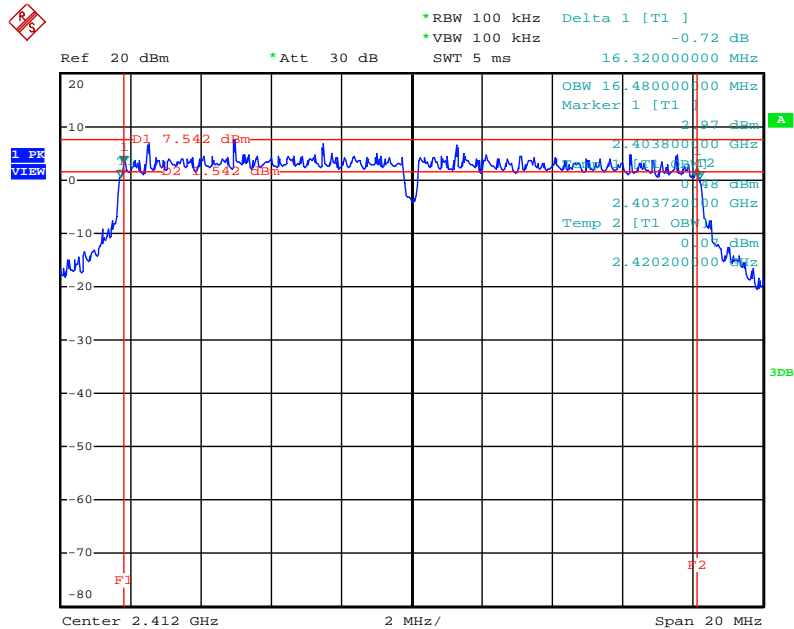

Date: 1.AUG.2011 21:53:07

4.5. Radiated Emissions Measurement

4.5.1. Limit

20dBc in any 100 kHz bandwidth outside the operating frequency band. In case the emission fall within the restricted band specified on 15.205(a), then the 15.209(a) limit in the table below has to be followed.

Frequencies (MHz)	Field Strength (micorvolts/meter)	Measurement Distance (meters)
0.009~0.490	2400/F(KHz)	300
0.490~1.705	24000/F(KHz)	30
1.705~30.0	30	30
30~88	100	3
88~216	150	3
216~960	200	3
Above 960	500	3

4.5.2. Measuring Instruments and Setting

Please refer to section 5 of equipments list in this report. The following table is the setting of spectrum analyzer and receiver.

Spectrum Parameter	Setting
Attenuation	Auto
Start Frequency	1000 MHz
Stop Frequency	10th carrier harmonic
RB / VB (Emission in restricted band)	1MHz / 1MHz for Peak, 1 MHz / 10Hz for Average
RB / VB (Emission in non-restricted band)	1MHz / 1MHz for peak

Receiver Parameter	Setting
Attenuation	Auto
Start ~ Stop Frequency	9kHz~150kHz / RB 200Hz for QP
Start ~ Stop Frequency	150kHz~30MHz / RB 9kHz for QP
Start ~ Stop Frequency	30MHz~1000MHz / RB 120kHz for QP

4.5.3. Test Procedures

1. Configure the EUT according to ANSI C63.10. The EUT was placed on the top of the turntable 0.8 meter above ground. The phase center of the receiving antenna mounted on the top of a height-variable antenna tower was placed 3 meters far away from the turntable.
2. Power on the EUT and all the supporting units. The turntable was rotated by 360 degrees to determine the position of the highest radiation.
3. The height of the broadband receiving antenna was varied between one meter and four meters above ground to find the maximum emissions field strength of both horizontal and vertical polarization.
4. For each suspected emissions, the antenna tower was scan (from 1 m to 4 m) and then the turntable was rotated (from 0 degree to 360 degrees) to find the maximum reading.
5. Set the test-receiver system to Peak or CISPR quasi-peak Detect Function with specified bandwidth under Maximum Hold Mode.
6. For emissions above 1GHz, use 1MHz VBW and RBW for peak reading. Then 1MHz RBW and 10Hz VBW for average reading in spectrum analyzer.
7. When the radiated emissions limits are expressed in terms of the average value of the emissions, and pulsed operation is employed, the measurement field strength shall be determined by averaging over one complete pulse train, including blanking intervals, as long as the pulse train does not exceed 0.1 seconds. As an alternative (provided the transmitter operates for longer than 0.1 seconds) or in cases where the pulse train exceeds 0.1 seconds, the measured field strength shall be determined from the average absolute voltage during a 0.1 second interval during which the field strength is at its maximum value.
8. If the emissions level of the EUT in peak mode was 3 dB lower than the average limit specified, then testing will be stopped and peak values of EUT will be reported, otherwise, the emissions which do not have 3 dB margin will be repeated one by one using the quasi-peak method for below 1GHz.
9. For testing above 1GHz, the emissions level of the EUT in peak mode was lower than average limit (that means the emissions level in peak mode also complies with the limit in average mode), then testing will be stopped and peak values of EUT will be reported, otherwise, the emissions will be measured in average mode again and reported.
10. In case the emission is lower than 30MHz, loop antenna has to be used for measurement and the recorded data should be QP measured by receiver. High – Low scan is not required in this case.

4.5.4. Test Setup Layout

For Radiated Emissions below 1GHz

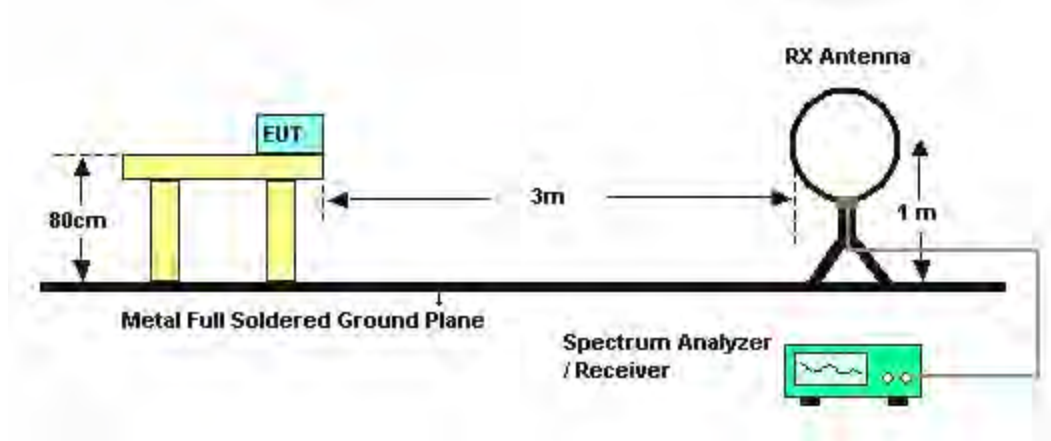

For Radiated Emissions above 1GHz

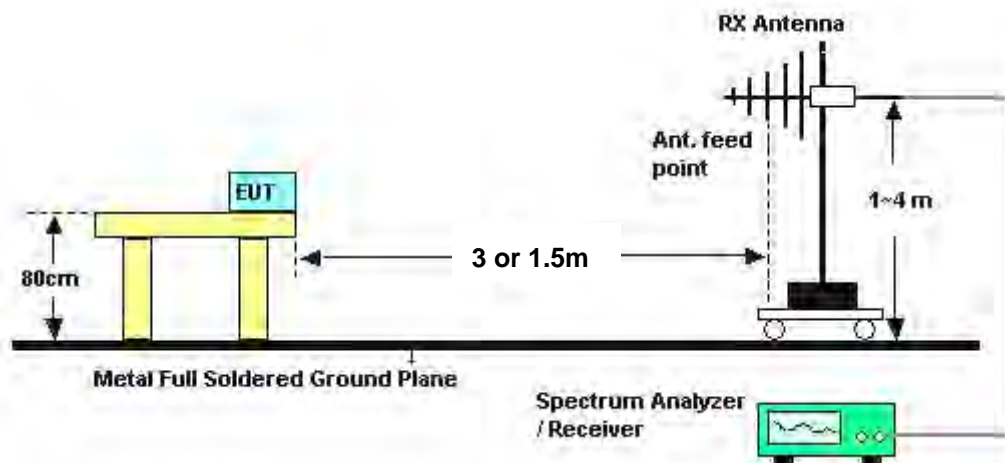

Above 10 GHz shall be extrapolated to the specified distance using an extrapolation factor of 20 dB/decade from 3m to 1.5m.

Distance extrapolation factor = $20 \log(\text{specific distance [3m]} / \text{test distance [1.5m]})$ (dB);

Limit line = specific limits (dBuV) + distance extrapolation factor [6 dB].

4.5.5. Test Deviation

There is no deviation with the original standard.

4.5.6. EUT Operation during Test

The EUT was programmed to be in continuously transmitting mode.

4.5.7. Results of Radiated Emissions (9kHz~30MHz)

Temperature	23°C	Humidity	65%
Test Engineer	Serway Li	Configurations	Normal Link
Test Date	Jun. 21, 2011		

Freq. (MHz)	Level (dBuV)	Over Limit (dB)	Limit Line (dBuV)	Remark
-	-	-	-	See Note

Note:

The amplitude of spurious emissions which are attenuated by more than 20 dB below the permissible value has no need to be reported.

Distance extrapolation factor = $40 \log(\text{specific distance} / \text{test distance})$ (dB);

Limit line = specific limits (dBuV) + distance extrapolation factor.

4.5.8. Results of Radiated Emissions (30MHz~1GHz)

<For Ant. 1 >

Temperature	23°C	Humidity	65%
Test Engineer	Serway Li	Configurations	Normal Link / Ant. 1

Horizontal

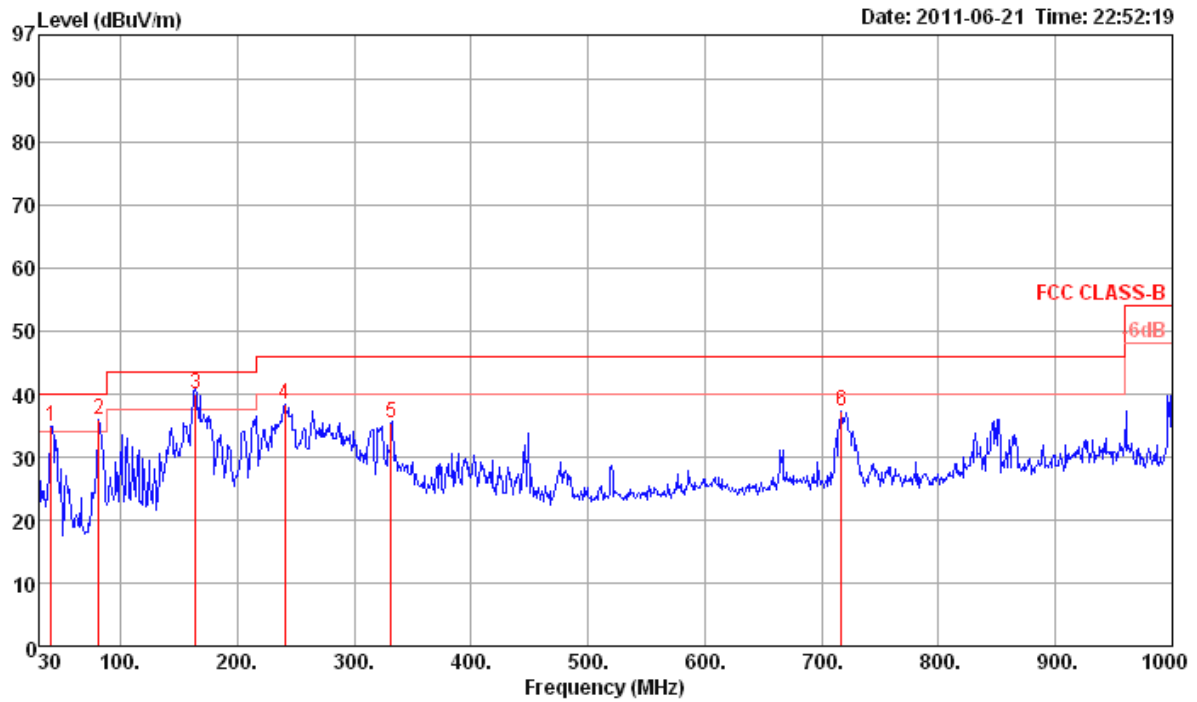

	Freq	Level	Limit	Over	Read	Cable	Antenna	Preamp	Remark	Pol/Phase
	MHz	dBuV/m	dBuV/m	dB	dBuV	dB	dB/m	dB		
1	40.67	34.84	40.00	-5.16	49.39	0.70	12.55	27.80	Peak	HORIZONTAL
2	81.41	35.97	40.00	-4.03	55.20	1.10	7.35	27.68	Peak	HORIZONTAL
3	163.86	39.91	43.50	-3.59	53.35	1.52	12.32	27.28	Peak	HORIZONTAL
4	240.49	38.47	46.00	-7.53	51.58	1.86	12.05	27.02	Peak	HORIZONTAL
5	331.67	35.42	46.00	-10.58	46.15	2.16	14.23	27.12	Peak	HORIZONTAL
6	716.76	37.33	46.00	-8.67	42.69	3.37	19.20	27.93	Peak	HORIZONTAL

Vertical

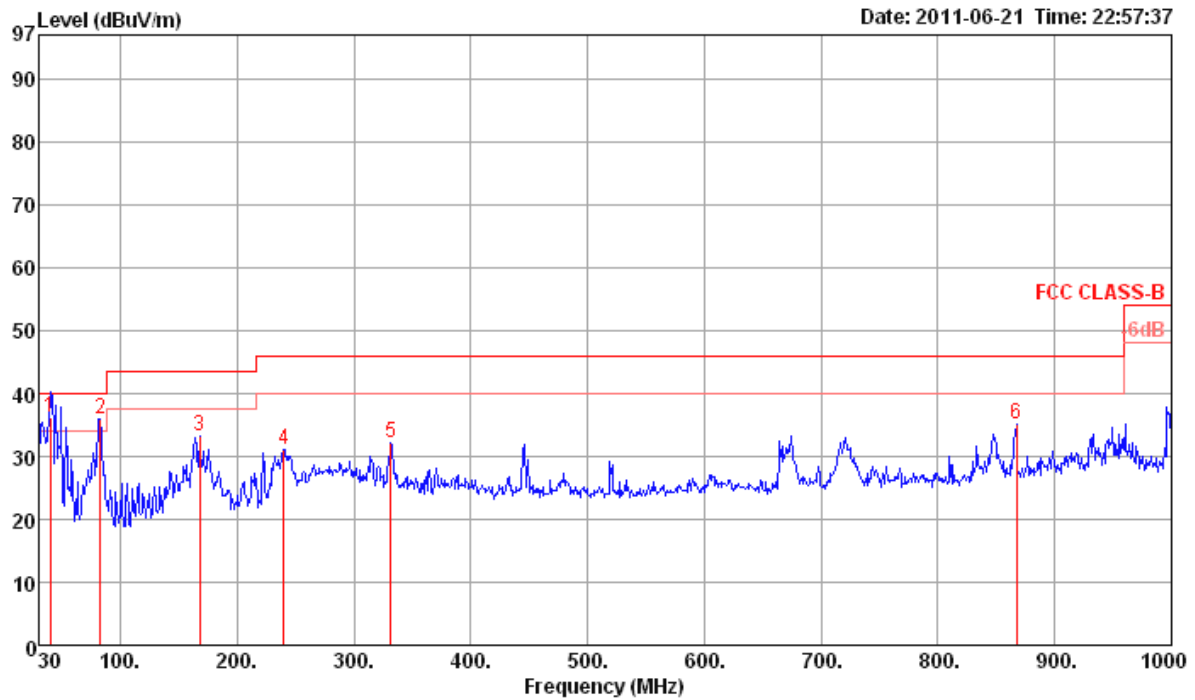

	Freq	Level	Limit	Over	Read	CableAntenna	Preamp	Remark	Pol/Phase
	MHz	dBuV/m	dBuV/m	dB	dBuV	dB	dB/m	dB	
1	40.00	36.33	40.00	-3.67	50.32	0.70	13.11	27.80	QP
2	82.38	35.91	40.00	-4.09	54.95	1.10	7.53	27.67	Peak
3	167.74	33.10	43.50	-10.40	46.21	1.54	12.61	27.26	Peak
4	239.52	31.19	46.00	-14.81	44.37	1.86	11.98	27.02	Peak
5	331.67	32.17	46.00	-13.83	42.90	2.16	14.23	27.12	Peak
6	867.11	35.03	46.00	-10.97	38.75	3.47	20.28	27.47	Peak

Note:

The amplitude of spurious emissions which are attenuated by more than 20 dB below the permissible value has no need to be reported.

Emission level (dBuV/m) = 20 log Emission level (uV/m).

Corrected Reading: Antenna Factor + Cable Loss + Read Level - Preamp Factor = Level.

4.5.9. Results for Radiated Emissions (1GHz~10th Harmonic)

<For Ant. 1 >

Temperature	23°C	Humidity	65%
Test Engineer	Serway Li	Configurations	IEEE 802.11n MCS0 20MHz Ch 1 / Ant. 1
Test Date	Jun. 16, 2011		

Horizontal

	Freq	Level	Limit Line	Over Limit	Read Level	Cable Loss	Antenna Factor	Preamp Factor	T/Pos	A/Pos	Remark	Pol/Phase
	MHz	dBuV/m	dBuV/m	dB	dBuV	dB	dB/m	dB	deg	cm		
1	4823.61	41.66	74.00	-32.34	40.32	3.31	33.06	35.03	279	100	Peak	HORIZONTAL
2	4824.05	29.29	54.00	-24.71	27.95	3.31	33.06	35.03	279	100	Average	HORIZONTAL

Vertical

	Freq	Level	Limit Line	Over Limit	Read Level	Cable Loss	Antenna Factor	Preamp Factor	T/Pos	A/Pos	Remark	Pol/Phase
	MHz	dBuV/m	dBuV/m	dB	dBuV	dB	dB/m	dB	deg	cm		
1	4824.08	42.98	74.00	-31.02	41.64	3.31	33.06	35.03	219	100	Peak	VERTICAL
2	4824.33	29.31	54.00	-24.69	27.97	3.31	33.06	35.03	219	100	Average	VERTICAL

Temperature	23°C	Humidity	65%
Test Engineer	Serway Li	Configurations	IEEE 802.11n MCS0 20MHz Ch 6 / Ant. 1
Test Date	Jun. 16, 2011		

Horizontal

	Freq	Level	Limit	Over	Read	Cable	Antenna	Preamp	T/Pos	A/Pos	Remark	Pol/Phase
	MHz	dBuV/m	dBuV/m	dB	dBuV	dB	dB/m	dB	deg	cm		
1	4873.58	41.80	74.00	-32.20	40.34	3.33	33.16	35.03	236	100	Peak	HORIZONTAL
2	4873.64	29.29	54.00	-24.71	27.83	3.33	33.16	35.03	236	100	Average	HORIZONTAL

Vertical

	Freq	Level	Limit	Over	Read	Cable	Antenna	Preamp	T/Pos	A/Pos	Remark	Pol/Phase
	MHz	dBuV/m	dBuV/m	dB	dBuV	dB	dB/m	dB	deg	cm		
1	4873.96	29.45	54.00	-24.55	27.99	3.33	33.16	35.03	180	100	Average	VERTICAL
2	4874.40	42.43	74.00	-31.57	40.97	3.33	33.16	35.03	180	100	Peak	VERTICAL

Temperature	23°C	Humidity	56%
Test Engineer	Serway Li	Configurations	IEEE 802.11n MCS0 20MHz Ch11 / Ant. 1
Test Date	Jun. 16, 2011		

Horizontal

	Freq	Level	Limit	Over	Read	Cable	Antenna	Preamp	T/Pos	A/Pos	Remark	Pol/Phase
	MHz	dBuV/m	dBuV/m	dB	dBuV	Loss	Factor	Factor	deg	cm		
1	4923.85	42.59	74.00	-31.41	40.99	3.35	33.26	35.01	296	100	Peak	HORIZONTAL
2	4924.44	28.81	54.00	-25.19	27.21	3.35	33.26	35.01	296	100	Average	HORIZONTAL

Vertical

	Freq	Level	Limit	Over	Read	Cable	Antenna	Preamp	T/Pos	A/Pos	Remark	Pol/Phase
	MHz	dBuV/m	dBuV/m	dB	dBuV	Loss	Factor	Factor	deg	cm		
1	4923.59	41.85	74.00	-32.15	40.25	3.35	33.26	35.01	230	100	Peak	VERTICAL
2	4923.98	29.41	54.00	-24.59	27.81	3.35	33.26	35.01	230	100	Average	VERTICAL

Temperature	23°C	Humidity	56%
Test Engineer	Serway Li	Configurations	IEEE 802.11n MCS0 40MHz Ch 3 / Ant. 1
Test Date	Jun. 16, 2011		

Horizontal

	Freq	Level	Limit	Over	Read	Cable	Antenna	Preamp	T/Pos	A/Pos	Remark	Pol/Phase
	MHz	dBuV/m	dBuV/m	dB	dBuV	dB	dB/m	dB	deg	cm		
1	4843.62	41.60	74.00	-32.40	40.22	3.32	33.09	35.03	249	100	Peak	HORIZONTAL
2	4844.17	29.22	54.00	-24.78	27.84	3.32	33.09	35.03	249	100	Average	HORIZONTAL

Vertical

	Freq	Level	Limit	Over	Read	Cable	Antenna	Preamp	T/Pos	A/Pos	Remark	Pol/Phase
	MHz	dBuV/m	dBuV/m	dB	dBuV	dB	dB/m	dB	deg	cm		
1	4843.92	42.35	74.00	-31.65	40.97	3.32	33.09	35.03	184	100	Peak	VERTICAL
2	4843.97	29.33	54.00	-24.67	27.95	3.32	33.09	35.03	184	100	Average	VERTICAL



Temperature	23°C	Humidity	56%
Test Engineer	Serway Li	Configurations	IEEE 802.11n MCS0 40MHz Ch 6 / Ant. 1
Test Date	Jun. 16, 2011		

Horizontal

	Freq	Level	Limit	Over	Read	Cable	Antenna	Preamp	T/Pos	A/Pos	Remark	Pol/Phase
	MHz	dBuV/m	dBuV/m	dB	dBuV	Loss	Factor	Factor	deg	cm		
1	4873.53	41.83	74.00	-32.17	40.37	3.33	33.16	35.03	220	100	Peak	HORIZONTAL
2	4874.44	29.25	54.00	-24.75	27.79	3.33	33.16	35.03	220	100	Average	HORIZONTAL

Vertical

	Freq	Level	Limit	Over	Read	Cable	Antenna	Preamp	T/Pos	A/Pos	Remark	Pol/Phase
	MHz	dBuV/m	dBuV/m	dB	dBuV	Loss	Factor	Factor	deg	cm		
1	4873.91	42.59	74.00	-31.41	41.13	3.33	33.16	35.03	138	100	Peak	VERTICAL
2	4874.05	29.40	54.00	-24.60	27.94	3.33	33.16	35.03	138	100	Average	VERTICAL

Temperature	23°C	Humidity	56%
Test Engineer	Serway Li	Configurations	IEEE 802.11n MCS0 40MHz Ch 9 / Ant. 1
Test Date	Jun. 16, 2011		

Horizontal

	Freq	Level	Limit	Over	Read	Cable	Antenna	Preamp	T/Pos	A/Pos	Remark	Pol/Phase
	MHz	dBuV/m	dBuV/m	dB	dBuV	Loss	Factor	Factor	deg	cm		
1	4904.10	42.98	74.00	-31.02	41.47	3.34	33.19	35.02	232	100	Peak	HORIZONTAL
2	4904.27	29.48	54.00	-24.52	27.97	3.34	33.19	35.02	232	100	Average	HORIZONTAL

Vertical

	Freq	Level	Limit	Over	Read	Cable	Antenna	Preamp	T/Pos	A/Pos	Remark	Pol/Phase
	MHz	dBuV/m	dBuV/m	dB	dBuV	Loss	Factor	Factor	deg	cm		
1	4903.89	29.55	54.00	-24.45	28.04	3.34	33.19	35.02	161	100	Average	VERTICAL
2	4904.24	43.07	74.00	-30.93	41.56	3.34	33.19	35.02	161	100	Peak	VERTICAL

Note:

The amplitude of spurious emissions which are attenuated by more than 20 dB below the permissible value has no need to be reported.

Emission level (dBuV/m) = 20 log Emission level (uV/m).

Corrected Reading: Antenna Factor + Cable Loss + Read Level - Preamp Factor = Level.



Temperature	23°C	Humidity	56%
Test Engineer	Serway Li	Configurations	IEEE 802.11b CH 1 / Ant. 1
Test Date	Jun. 16, 2011		

Horizontal

	Freq	Level	Limit Line	Over Limit	Read Level	CableAntenna Loss	Antenna Factor	Preamp Factor	T/Pos	A/Pos	Remark	Pol/Phase
	MHz	dBuV/m	dBuV/m	dB	dBuV	dB	dB/m	dB	deg	cm		
1	4824.17	29.58	54.00	-24.42	28.24	3.31	33.06	35.03	160	113	Average	HORIZONTAL
2	4824.29	42.26	74.00	-31.74	40.92	3.31	33.06	35.03	160	113	Peak	HORIZONTAL

Vertical

	Freq	Level	Limit Line	Over Limit	Read Level	CableAntenna Loss	Antenna Factor	Preamp Factor	T/Pos	A/Pos	Remark	Pol/Phase
	MHz	dBuV/m	dBuV/m	dB	dBuV	dB	dB/m	dB	deg	cm		
1	4823.99	33.85	54.00	-20.15	32.51	3.31	33.06	35.03	296	107	Average	VERTICAL
2	4824.35	47.20	74.00	-26.80	45.86	3.31	33.06	35.03	296	107	Peak	VERTICAL

Temperature	23°C	Humidity	56%
Test Engineer	Serway Li	Configurations	IEEE 802.11b CH 6 / Ant. 1
Test Date	Jun. 16, 2011		

Horizontal

	Freq	Level	Limit	Over	Read	Cable	Antenna	Preamp	T/Pos	A/Pos	Remark	Pol/Phase
	MHz	dBuV/m	dBuV/m	dB	dBuV	dB	dB/m	dB	deg	cm		
1	4873.77	44.61	74.00	-29.39	43.15	3.33	33.16	35.03	63	111	Peak	HORIZONTAL
2	4873.98	36.46	54.00	-17.54	35.00	3.33	33.16	35.03	63	111	Average	HORIZONTAL

Vertical

	Freq	Level	Limit	Over	Read	Cable	Antenna	Preamp	T/Pos	A/Pos	Remark	Pol/Phase
	MHz	dBuV/m	dBuV/m	dB	dBuV	dB	dB/m	dB	deg	cm		
1	4873.96	39.76	54.00	-14.24	38.30	3.33	33.16	35.03	26	100	Average	VERTICAL
2	4873.98	46.34	74.00	-27.66	44.88	3.33	33.16	35.03	26	100	Peak	VERTICAL

Temperature	23°C	Humidity	56%
Test Engineer	Serway Li	Configurations	IEEE 802.11b CH 11 / Ant. 1
Test Date	Jun. 16, 2011		

Horizontal

	Freq	Level	Limit Line	Over Limit	Read Level	Cable Loss	Antenna Factor	Preamp Factor	T/Pos	A/Pos	Remark	Pol/Phase
	MHz	dBuV/m	dBuV/m	dB	dBuV	dB	dB/m	dB	deg	cm		
1	4924.02	33.91	54.00	-20.09	32.31	3.35	33.26	35.01	159	100	Average	HORIZONTAL
2	4924.43	43.14	74.00	-30.86	41.54	3.35	33.26	35.01	159	100	Peak	HORIZONTAL

Vertical

	Freq	Level	Limit Line	Over Limit	Read Level	Cable Loss	Antenna Factor	Preamp Factor	T/Pos	A/Pos	Remark	Pol/Phase
	MHz	dBuV/m	dBuV/m	dB	dBuV	dB	dB/m	dB	deg	cm		
1	4923.78	44.93	74.00	-29.07	43.33	3.35	33.26	35.01	268	100	Peak	VERTICAL
2	4923.96	37.20	54.00	-16.80	35.60	3.35	33.26	35.01	268	100	Average	VERTICAL

Temperature	23°C	Humidity	56%
Test Engineer	Serway Li	Configurations	IEEE 802.11g CH 1 / Ant. 1
Test Date	Jun. 16, 2011		

Horizontal

	Freq	Level	Limit Line	Over Limit	Read Level	Cable Loss	Antenna Factor	Preamp Factor	T/Pos	A/Pos	Remark	Pol/Phase
	MHz	dBuV/m	dBuV/m	dB	dBuV	dB	dB/m	dB	deg	cm		
1	4873.75	29.09	54.00	-24.91	27.63	3.33	33.16	35.03	216	100	Average	HORIZONTAL
2	4874.08	41.86	74.00	-32.14	40.40	3.33	33.16	35.03	216	100	Peak	HORIZONTAL

Vertical

	Freq	Level	Limit Line	Over Limit	Read Level	Cable Loss	Antenna Factor	Preamp Factor	T/Pos	A/Pos	Remark	Pol/Phase
	MHz	dBuV/m	dBuV/m	dB	dBuV	dB	dB/m	dB	deg	cm		
1	4873.99	41.69	74.00	-32.31	40.23	3.33	33.16	35.03	145	100	Peak	VERTICAL
2	4874.28	29.25	54.00	-24.75	27.79	3.33	33.16	35.03	145	100	Average	VERTICAL

Temperature	23°C	Humidity	56%
Test Engineer	Serway Li	Configurations	IEEE 802.11g CH 6 / Ant. 1
Test Date	Jun. 16, 2011		

Horizontal

	Freq	Level	Limit	Over	Read	Cable	Antenna	Preamp	T/Pos	A/Pos	Remark	Pol/Phase
	MHz	dBuV/m	dBuV/m	dB	dBuV	Loss	Factor	Factor	deg	cm		
1	4873.55	42.47	74.00	-31.53	41.01	3.33	33.16	35.03	199	100	Peak	HORIZONTAL
2	4873.69	29.17	54.00	-24.83	27.71	3.33	33.16	35.03	199	100	Average	HORIZONTAL

Vertical

	Freq	Level	Limit	Over	Read	Cable	Antenna	Preamp	T/Pos	A/Pos	Remark	Pol/Phase
	MHz	dBuV/m	dBuV/m	dB	dBuV	Loss	Factor	Factor	deg	cm		
1	4873.75	29.57	54.00	-24.43	28.11	3.33	33.16	35.03	121	100	Average	VERTICAL
2	4874.48	41.99	74.00	-32.01	40.53	3.33	33.16	35.03	121	100	Peak	VERTICAL

Temperature	23°C	Humidity	56%
Test Engineer	Serway Li	Configurations	IEEE 802.11g CH 11 / Ant. 1
Test Date	Jun. 16, 2011		

Horizontal

	Freq	Level	Limit Line	Over Limit	Read Level	Cable Loss	Antenna Factor	Preamp Factor	T/Pos	A/Pos	Remark	Pol/Phase
	MHz	dBuV/m	dBuV/m	dB	dBuV	dB	dB/m	dB	deg	cm		
1	4924.20	28.72	54.00	-25.28	27.12	3.35	33.26	35.01	150	100	Average	HORIZONTAL
2	4924.22	42.27	74.00	-31.73	40.67	3.35	33.26	35.01	150	100	Peak	HORIZONTAL

Vertical

	Freq	Level	Limit Line	Over Limit	Read Level	Cable Loss	Antenna Factor	Preamp Factor	T/Pos	A/Pos	Remark	Pol/Phase
	MHz	dBuV/m	dBuV/m	dB	dBuV	dB	dB/m	dB	deg	cm		
1	4923.81	29.96	54.00	-24.04	28.36	3.35	33.26	35.01	205	100	Average	VERTICAL
2	4924.05	43.57	74.00	-30.43	41.97	3.35	33.26	35.01	205	100	Peak	VERTICAL

Note:

The amplitude of spurious emissions that are attenuated by more than 20dB below the permissible value has no need to be reported.

Emission level (dBuV/m) = 20 log Emission level (uV/m).

Corrected Reading: Antenna Factor + Cable Loss + Read Level - Preamp Factor = Level.

<For Ant. 2>

Temperature	23°C	Humidity	65%
Test Engineer	Serway Li	Configurations	IEEE 802.11n MCS0 20MHz Ch 1 / Ant. 2
Test Date	Jun. 13, 2011		

Horizontal

	Freq	Level	Limit	Over	Read	CableAntenna	Preamp	T/Pos	A/Pos	Remark	Pol/Phase
	MHz	dBuV/m	dBuV/m	dB	dBuV	Loss	Factor	Factor	deg	cm	
1	4825.83	29.17	54.00	-24.83	27.83	3.31	33.06	35.03	300	99 Average	HORIZONTAL
2	4827.80	42.69	74.00	-31.31	41.35	3.31	33.06	35.03	300	99 Peak	HORIZONTAL

Vertical

	Freq	Level	Limit	Over	Read	CableAntenna	Preamp	T/Pos	A/Pos	Remark	Pol/Phase
	MHz	dBuV/m	dBuV/m	dB	dBuV	Loss	Factor	Factor	deg	cm	
1	4827.38	29.39	54.00	-24.61	28.05	3.31	33.06	35.03	219	99 Average	VERTICAL
2	4828.22	42.51	74.00	-31.49	41.17	3.31	33.06	35.03	219	99 Peak	VERTICAL

Temperature	23°C	Humidity	65%
Test Engineer	Serway Li	Configurations	IEEE 802.11n MCS0 20MHz Ch 6 / Ant. 2
Test Date	Jun. 13, 2011		

Horizontal

	Freq	Level	Limit	Over	Read	CableAntenna	Preamp	T/Pos	A/Pos	Remark	Pol/Phase	
	MHz	dBuV/m	dBuV/m	dB	dBuV	dB	dB/m	dB	deg	cm		
1	4874.16	29.71	54.00	-24.29	28.25	3.33	33.16	35.03	285	100	Average	HORIZONTAL
2	4878.47	42.26	74.00	-31.74	40.80	3.33	33.16	35.03	285	100	Peak	HORIZONTAL

Vertical

	Freq	Level	Limit	Over	Read	CableAntenna	Preamp	T/Pos	A/Pos	Remark	Pol/Phase	
	MHz	dBuV/m	dBuV/m	dB	dBuV	dB	dB/m	dB	deg	cm		
1	4875.04	42.24	74.00	-31.76	40.78	3.33	33.16	35.03	186	100	Peak	VERTICAL
2	4877.21	30.02	54.00	-23.98	28.56	3.33	33.16	35.03	186	100	Average	VERTICAL

Temperature	23°C	Humidity	56%
Test Engineer	Serway Li	Configurations	IEEE 802.11n MCS0 20MHz Ch11 / Ant. 2
Test Date	Jun. 13, 2011		

Horizontal

	Freq	Level	Limit Line	Over Limit	Read Level	CableAntenna Loss	Antenna Factor	Preamp Factor	T/Pos	A/Pos	Remark	Pol/Phase
	MHz	dBuV/m	dBuV/m	dB	dBuV	dB	dB/m	dB	deg	cm		
1	4924.21	28.60	54.00	-25.40	27.00	3.35	33.26	35.01	213	100	Average	HORIZONTAL
2	4925.76	40.75	74.00	-33.25	39.15	3.35	33.26	35.01	213	100	Peak	HORIZONTAL

Vertical

	Freq	Level	Limit Line	Over Limit	Read Level	CableAntenna Loss	Antenna Factor	Preamp Factor	T/Pos	A/Pos	Remark	Pol/Phase
	MHz	dBuV/m	dBuV/m	dB	dBuV	dB	dB/m	dB	deg	cm		
1	4921.98	41.83	74.00	-32.17	40.23	3.35	33.26	35.01	138	100	Peak	VERTICAL
2	4922.21	28.70	54.00	-25.30	27.10	3.35	33.26	35.01	138	100	Average	VERTICAL



Temperature	23°C	Humidity	56%
Test Engineer	Serway Li	Configurations	IEEE 802.11n MCS0 40MHz Ch 3 / Ant. 2
Test Date	Jun. 13, 2011		

Horizontal

	Freq	Level	Limit	Over	Read	Cable	Antenna	Preamp	T/Pos	A/Pos	Remark	Pol/Phase
	MHz	dBuV/m	dBuV/m	dB	dBuV	dB	dB/m	dB	deg	cm		
1	4841.89	41.80	74.00	-32.20	40.42	3.32	33.09	35.03	180	100	Peak	HORIZONTAL
2	4844.11	29.28	54.00	-24.72	27.90	3.32	33.09	35.03	180	100	Average	HORIZONTAL

Vertical

	Freq	Level	Limit	Over	Read	Cable	Antenna	Preamp	T/Pos	A/Pos	Remark	Pol/Phase
	MHz	dBuV/m	dBuV/m	dB	dBuV	dB	dB/m	dB	deg	cm		
1	4843.95	29.18	54.00	-24.82	27.80	3.32	33.09	35.03	165	100	Average	VERTICAL
2	4845.72	41.89	74.00	-32.11	40.51	3.32	33.09	35.03	165	100	Peak	VERTICAL

Temperature	23°C	Humidity	56%
Test Engineer	Serway Li	Configurations	IEEE 802.11n MCS0 40MHz Ch 6 / Ant. 2
Test Date	Jun. 13, 2011		

Horizontal

	Freq	Level	Limit Line	Over Limit	Read Level	CableAntenna Loss	Antenna Factor	Preamp Factor	T/Pos	A/Pos	Remark	Pol/Phase
	MHz	dBuV/m	dBuV/m	dB	dBuV	dB	dB/m	dB	deg	cm		
1	4877.89	29.81	54.00	-24.19	28.35	3.33	33.16	35.03	144	100	Average	HORIZONTAL
2	4878.84	42.95	74.00	-31.05	41.49	3.33	33.16	35.03	144	100	Peak	HORIZONTAL

Vertical

	Freq	Level	Limit Line	Over Limit	Read Level	CableAntenna Loss	Antenna Factor	Preamp Factor	T/Pos	A/Pos	Remark	Pol/Phase
	MHz	dBuV/m	dBuV/m	dB	dBuV	dB	dB/m	dB	deg	cm		
1	4876.72	42.62	74.00	-31.38	41.16	3.33	33.16	35.03	180	100	Peak	VERTICAL
2	4877.25	29.79	54.00	-24.21	28.33	3.33	33.16	35.03	180	100	Average	VERTICAL



Temperature	23°C	Humidity	56%
Test Engineer	Serway Li	Configurations	IEEE 802.11n MCS0 40MHz Ch 9 / Ant. 2
Test Date	Jun. 13, 2011		

Horizontal

	Freq	Level	Limit Line	Over Limit	Read Level	Cable Loss	Antenna Factor	Preamp Factor	T/Pos	A/Pos	Remark	Pol/Phase
	MHz	dBuV/m	dBuV/m	dB	dBuV	dB	dB/m	dB	deg	cm		
1	4902.81	29.08	54.00	-24.92	27.57	3.34	33.19	35.02	144	100	Average	HORIZONTAL
2	4903.53	41.71	74.00	-32.29	40.20	3.34	33.19	35.02	144	100	Peak	HORIZONTAL

Vertical

	Freq	Level	Limit Line	Over Limit	Read Level	Cable Loss	Antenna Factor	Preamp Factor	T/Pos	A/Pos	Remark	Pol/Phase
	MHz	dBuV/m	dBuV/m	dB	dBuV	dB	dB/m	dB	deg	cm		
1	4901.50	29.20	54.00	-24.80	27.69	3.34	33.19	35.02	126	100	Average	VERTICAL
2	4903.34	41.64	74.00	-32.36	40.13	3.34	33.19	35.02	126	100	Peak	VERTICAL

Note:

The amplitude of spurious emissions which are attenuated by more than 20 dB below the permissible value has no need to be reported.

Emission level (dBuV/m) = 20 log Emission level (uV/m).

Corrected Reading: Antenna Factor + Cable Loss + Read Level - Preamp Factor = Level.

Temperature	23°C	Humidity	56%
Test Engineer	Serway Li	Configurations	IEEE 802.11b CH 1 / Ant. 2
Test Date	Jun. 13, 2011		

Horizontal

	Freq	Level	Limit	Over	Read	Cable	Preamp	Antenna	T/Pos	A/Pos	Remark	Pol/Phase
	MHz	dBuV/m	dBuV/m	dB	dBuV	dB	dB	dB/m	deg	cm		
1 a	4823.56	27.29	54.00	-26.71	27.09	3.00	35.26	32.46	219	100	Average	HORIZONTAL
2 p	4823.59	41.01	74.00	-32.99	40.81	3.00	35.26	32.46	219	100	Peak	HORIZONTAL

Vertical

	Freq	Level	Limit	Over	Read	Cable	Preamp	Antenna	T/Pos	A/Pos	Remark	Pol/Phase
	MHz	dBuV/m	dBuV/m	dB	dBuV	dB	dB	dB/m	deg	cm		
1 a	4823.96	28.61	54.00	-25.39	28.41	3.00	35.26	32.46	292	100	Average	VERTICAL
2 p	4824.13	42.04	74.00	-31.96	41.84	3.00	35.26	32.46	292	100	Peak	VERTICAL

Temperature	23°C	Humidity	56%
Test Engineer	Serway Li	Configurations	IEEE 802.11b CH 6 / Ant. 2
Test Date	Jun. 13, 2011		

Horizontal

	Freq	Level	Limit Line	Over Limit	Read Level	Cable Loss	Preamp Factor	Antenna Factor	T/Pos	A/Pos	Remark	Pol/Phase
	MHz	dBuV/m	dBuV/m	dB	dBuV	dB	dB	dB/m	deg	cm		
1 p	4873.86	43.11	74.00	-30.89	42.69	3.01	35.15	32.56	245	116	Peak	HORIZONTAL
2 a	4873.94	30.11	54.00	-23.89	29.69	3.01	35.15	32.56	245	116	Average	HORIZONTAL

Vertical

	Freq	Level	Limit Line	Over Limit	Read Level	Cable Loss	Preamp Factor	Antenna Factor	T/Pos	A/Pos	Remark	Pol/Phase
	MHz	dBuV/m	dBuV/m	dB	dBuV	dB	dB	dB/m	deg	cm		
1 a	4873.94	29.69	54.00	-24.31	29.27	3.01	35.15	32.56	290	100	Average	VERTICAL
2 p	4874.26	42.77	74.00	-31.23	42.35	3.01	35.15	32.56	290	100	Peak	VERTICAL

Temperature	23°C	Humidity	56%
Test Engineer	Serway Li	Configurations	IEEE 802.11b CH 11 / Ant. 2
Test Date	Jun. 13, 2011		

Horizontal

	Freq	Level	Limit	Over	Read	Cable	Preamp	Antenna	T/Pos	A/Pos	Remark	Pol/Phase
	MHz	dBuV/m	dBuV/m	dB	dBuV	dB	dB	dB/m	deg	cm		
1 a	4924.04	30.24	54.00	-23.76	29.59	3.02	35.03	32.66	135	100	Average	HORIZONTAL
2 p	4924.37	41.80	74.00	-32.20	41.15	3.02	35.03	32.66	135	100	Peak	HORIZONTAL

Vertical

	Freq	Level	Limit	Over	Read	Cable	Preamp	Antenna	T/Pos	A/Pos	Remark	Pol/Phase
	MHz	dBuV/m	dBuV/m	dB	dBuV	dB	dB	dB/m	deg	cm		
1 a	4923.95	30.72	54.00	-23.28	30.07	3.02	35.03	32.66	342	100	Average	VERTICAL
2 p	4924.06	42.95	74.00	-31.05	42.30	3.02	35.03	32.66	342	100	Peak	VERTICAL

Temperature	23°C	Humidity	56%
Test Engineer	Serway Li	Configurations	IEEE 802.11g CH 1 / Ant. 2
Test Date	Jun. 13, 2011		

Horizontal

	Freq	Level	Limit Line	Over Limit	Read Level	Cable Loss	Antenna Factor	Preamp Factor	T/Pos	A/Pos	Remark	Pol/Phase
	MHz	dBuV/m	dBuV/m	dB	dBuV	dB	dB/m	dB	deg	cm		
1	4825.65	29.20	54.00	-24.80	27.86	3.31	33.06	35.03	216	100	Average	HORIZONTAL
2	4826.16	42.05	74.00	-31.95	40.71	3.31	33.06	35.03	216	100	Peak	HORIZONTAL

Vertical

	Freq	Level	Limit Line	Over Limit	Read Level	Cable Loss	Antenna Factor	Preamp Factor	T/Pos	A/Pos	Remark	Pol/Phase
	MHz	dBuV/m	dBuV/m	dB	dBuV	dB	dB/m	dB	deg	cm		
1	4823.27	42.27	74.00	-31.73	40.93	3.31	33.06	35.03	166	100	Peak	VERTICAL
2	4825.80	29.37	54.00	-24.63	28.03	3.31	33.06	35.03	166	100	Average	VERTICAL

Temperature	23°C	Humidity	56%
Test Engineer	Serway Li	Configurations	IEEE 802.11g CH 6 / Ant. 2
Test Date	Jun. 13, 2011		

Horizontal

	Freq	Level	Limit Line	Over Limit	Read Level	Cable Loss	Antenna Factor	Preamp Factor	T/Pos	A/Pos	Remark	Pol/Phase
	MHz	dBuV/m	dBuV/m	dB	dBuV	dB	dB/m	dB	deg	cm		
1	4873.97	42.33	74.00	-31.67	40.87	3.33	33.16	35.03	129	100	Peak	HORIZONTAL
2	4875.54	29.72	54.00	-24.28	28.26	3.33	33.16	35.03	129	100	Average	HORIZONTAL

Vertical

	Freq	Level	Limit Line	Over Limit	Read Level	Cable Loss	Antenna Factor	Preamp Factor	T/Pos	A/Pos	Remark	Pol/Phase
	MHz	dBuV/m	dBuV/m	dB	dBuV	dB	dB/m	dB	deg	cm		
1	4874.10	29.87	54.00	-24.13	28.41	3.33	33.16	35.03	212	100	Average	VERTICAL
2	4875.78	42.37	74.00	-31.63	40.91	3.33	33.16	35.03	212	100	Peak	VERTICAL

Temperature	23°C	Humidity	56%
Test Engineer	Serway Li	Configurations	IEEE 802.11g CH 11 / Ant. 2
Test Date	Jun. 13, 2011		

Horizontal

	Freq	Level	Limit Line	Over Limit	Read Level	Cable Loss	Antenna Factor	Preamp Factor	T/Pos	A/Pos	Remark	Pol/Phase
	MHz	dBuV/m	dBuV/m	dB	dBuV	dB	dB/m	dB	deg	cm		
1	4923.48	41.54	74.00	-32.46	39.94	3.35	33.26	35.01	206	100	Peak	HORIZONTAL
2	4925.25	28.69	54.00	-25.31	27.09	3.35	33.26	35.01	206	100	Average	HORIZONTAL

Vertical

	Freq	Level	Limit Line	Over Limit	Read Level	Cable Loss	Antenna Factor	Preamp Factor	T/Pos	A/Pos	Remark	Pol/Phase
	MHz	dBuV/m	dBuV/m	dB	dBuV	dB	dB/m	dB	deg	cm		
1	4921.52	28.71	54.00	-25.29	27.14	3.35	33.23	35.01	222	100	Average	VERTICAL
2	4925.37	42.13	74.00	-31.87	40.53	3.35	33.26	35.01	222	100	Peak	VERTICAL

Note:

The amplitude of spurious emissions that are attenuated by more than 20dB below the permissible value has no need to be reported.

Emission level (dBuV/m) = 20 log Emission level (uV/m).

Corrected Reading: Antenna Factor + Cable Loss + Read Level - Preamp Factor = Level.

<For Ant. 3>

Temperature	23°C	Humidity	65%
Test Engineer	Serway Li	Configurations	IEEE 802.11n MCS0 20MHz Ch 1 / Ant. 3
Test Date	Jun. 16, 2011		

Horizontal

	Freq	Level	Limit Line	Over Limit	Read Level	Cable Loss	Preamp Factor	Antenna Factor	T/Pos	A/Pos	Remark	Pol/Phase
	MHz	dBuV/m	dBuV/m	dB	dBuV	dB	dB	dB/m	deg	cm		
1 p	4823.53	42.44	74.00	-31.56	40.86	4.38	35.26	32.46	277	100	Peak	HORIZONTAL
2 a	4823.63	29.88	54.00	-24.12	28.30	4.38	35.26	32.46	277	100	Average	HORIZONTAL

Vertical

	Freq	Level	Limit Line	Over Limit	Read Level	Cable Loss	Preamp Factor	Antenna Factor	T/Pos	A/Pos	Remark	Pol/Phase
	MHz	dBuV/m	dBuV/m	dB	dBuV	dB	dB	dB/m	deg	cm		
1 a	4823.98	32.96	54.00	-21.04	31.38	4.38	35.26	32.46	216	100	Average	VERTICAL
2 p	4824.45	44.79	74.00	-29.21	43.21	4.38	35.26	32.46	216	100	Peak	VERTICAL

Temperature	23°C	Humidity	65%
Test Engineer	Serway Li	Configurations	IEEE 802.11n MCS0 20MHz Ch 6 / Ant. 3
Test Date	Jun. 16, 2011		

Horizontal

	Freq	Level	Limit Line	Over Limit	Read Level	Cable Loss	Preamp Factor	Antenna Factor	T/Pos	A/Pos	Remark	Pol/Phase
	MHz	dBuV/m	dBuV/m	dB	dBuV	dB	dB	dB/m	deg	cm		
1 a	4873.76	29.73	54.00	-24.27	27.92	4.40	35.15	32.56	291	100	Average	HORIZONTAL
2 p	4873.88	42.61	74.00	-31.39	40.80	4.40	35.15	32.56	291	100	Peak	HORIZONTAL

Vertical

	Freq	Level	Limit Line	Over Limit	Read Level	Cable Loss	Preamp Factor	Antenna Factor	T/Pos	A/Pos	Remark	Pol/Phase
	MHz	dBuV/m	dBuV/m	dB	dBuV	dB	dB	dB/m	deg	cm		
1 a	4873.58	33.87	54.00	-20.13	32.06	4.40	35.15	32.56	186	100	Average	VERTICAL
2 p	4874.10	45.39	74.00	-28.61	43.58	4.40	35.15	32.56	186	100	Peak	VERTICAL

Temperature	23°C	Humidity	56%
Test Engineer	Serway Li	Configurations	IEEE 802.11n MCS0 20MHz Ch11 / Ant. 3
Test Date	Jun. 16, 2011		

Horizontal

	Freq	Level	Limit Line	Over Limit	Read Level	Cable Loss	Preamp Factor	Antenna Factor	T/Pos	A/Pos	Remark	Pol/Phase
	MHz	dBuV/m	dBuV/m	dB	dBuV	dB	dB	dB/m	deg	cm		
1 p	4923.53	43.28	74.00	-30.72	41.23	4.42	35.03	32.66	320	100	Peak	HORIZONTAL
2 a	4924.03	30.43	54.00	-23.57	28.38	4.42	35.03	32.66	320	100	Average	HORIZONTAL

Vertical

	Freq	Level	Limit Line	Over Limit	Read Level	Cable Loss	Preamp Factor	Antenna Factor	T/Pos	A/Pos	Remark	Pol/Phase
	MHz	dBuV/m	dBuV/m	dB	dBuV	dB	dB	dB/m	deg	cm		
1 a	4923.92	32.38	54.00	-21.62	30.33	4.42	35.03	32.66	262	100	Average	VERTICAL
2 p	4924.22	44.61	74.00	-29.39	42.56	4.42	35.03	32.66	262	100	Peak	VERTICAL

Temperature	23°C	Humidity	56%
Test Engineer	Serway Li	Configurations	IEEE 802.11n MCS0 40MHz Ch 3 / Ant. 3
Test Date	Jun. 16, 2011		

Horizontal

	Freq	Level	Limit Line	Over Limit	Read Level	Cable Loss	Preamp Factor	Antenna Factor	T/Pos	A/Pos	Remark	Pol/Phase
	MHz	dBuV/m	dBuV/m	dB	dBuV	dB	dB	dB/m	deg	cm		
1 p	4843.53	42.85	74.00	-31.15	41.17	4.39	35.20	32.49	266	100	Peak	HORIZONTAL
2 a	4844.15	29.90	54.00	-24.10	28.22	4.39	35.20	32.49	266	100	Average	HORIZONTAL

Vertical

	Freq	Level	Limit Line	Over Limit	Read Level	Cable Loss	Preamp Factor	Antenna Factor	T/Pos	A/Pos	Remark	Pol/Phase
	MHz	dBuV/m	dBuV/m	dB	dBuV	dB	dB	dB/m	deg	cm		
1 p	4844.17	42.86	74.00	-31.14	41.18	4.39	35.20	32.49	167	100	Peak	VERTICAL
2 a	4844.25	30.86	54.00	-23.14	29.18	4.39	35.20	32.49	167	100	Average	VERTICAL

Temperature	23°C	Humidity	56%
Test Engineer	Serway Li	Configurations	IEEE 802.11n MCS0 40MHz Ch 6 / Ant. 3
Test Date	Jun. 16, 2011		

Horizontal

	Freq	Level	Limit Line	Over Limit	Read Level	Cable Loss	Preamp Factor	Antenna Factor	T/Pos	A/Pos	Remark	Pol/Phase
	MHz	dBuV/m	dBuV/m	dB	dBuV	dB	dB	dB/m	deg	cm		
1 p	4873.58	43.24	74.00	-30.76	41.43	4.40	35.15	32.56	265	100	Peak	HORIZONTAL
2 a	4873.83	29.96	54.00	-24.04	28.15	4.40	35.15	32.56	265	100	Average	HORIZONTAL

Vertical

	Freq	Level	Limit Line	Over Limit	Read Level	Cable Loss	Preamp Factor	Antenna Factor	T/Pos	A/Pos	Remark	Pol/Phase
	MHz	dBuV/m	dBuV/m	dB	dBuV	dB	dB	dB/m	deg	cm		
1 a	4874.09	32.05	54.00	-21.95	30.24	4.40	35.15	32.56	179	100	Average	VERTICAL
2 p	4874.16	44.85	74.00	-29.15	43.04	4.40	35.15	32.56	179	100	Peak	VERTICAL

Temperature	23°C	Humidity	56%
Test Engineer	Serway Li	Configurations	IEEE 802.11n MCS0 40MHz Ch 9 / Ant. 3
Test Date	Jun. 16, 2011		

Horizontal

	Freq	Level	Limit Line	Over Limit	Read Level	Cable Loss	Preamp Factor	Antenna Factor	T/Pos	A/Pos	Remark	Pol/Phase
	MHz	dBuV/m	dBuV/m	dB	dBuV	dB	dB	dB/m	deg	cm		
1 p	4903.67	43.91	74.00	-30.09	41.96	4.41	35.09	32.63	201	100	Peak	HORIZONTAL
2 a	4904.38	30.65	54.00	-23.35	28.70	4.41	35.09	32.63	201	100	Average	HORIZONTAL

Vertical

	Freq	Level	Limit Line	Over Limit	Read Level	Cable Loss	Preamp Factor	Antenna Factor	T/Pos	A/Pos	Remark	Pol/Phase
	MHz	dBuV/m	dBuV/m	dB	dBuV	dB	dB	dB/m	deg	cm		
1 p	4903.72	44.14	74.00	-29.86	42.19	4.41	35.09	32.63	139	100	Peak	VERTICAL
2 a	4904.06	30.68	54.00	-23.32	28.73	4.41	35.09	32.63	139	100	Average	VERTICAL

Note:

The amplitude of spurious emissions which are attenuated by more than 20 dB below the permissible value has no need to be reported.

Emission level (dBuV/m) = 20 log Emission level (uV/m).

Corrected Reading: Antenna Factor + Cable Loss + Read Level - Preamp Factor = Level.

Temperature	23°C	Humidity	56%
Test Engineer	Serway Li	Configurations	IEEE 802.11b CH 1 / Ant. 3
Test Date	Jun. 16, 2011		

Horizontal

	Freq	Level	Limit Line	Over Limit	Read Level	Cable Loss	Preamp Factor	Antenna Factor	T/Pos	A/Pos	Remark	Pol/Phase
	MHz	dBuV/m	dBuV/m	dB	dBuV	dB	dB	dB/m	deg	cm		
1 a	4824.05	29.91	54.00	-24.09	28.33	4.38	35.26	32.46	232	100	Average	HORIZONTAL
2 p	4824.27	43.08	74.00	-30.92	41.50	4.38	35.26	32.46	232	100	Peak	HORIZONTAL

Vertical

	Freq	Level	Limit Line	Over Limit	Read Level	Cable Loss	Preamp Factor	Antenna Factor	T/Pos	A/Pos	Remark	Pol/Phase
	MHz	dBuV/m	dBuV/m	dB	dBuV	dB	dB	dB/m	deg	cm		
1 a	4824.02	33.59	54.00	-20.41	32.01	4.38	35.26	32.46	192	100	Average	VERTICAL
2 p	4824.31	44.19	74.00	-29.81	42.61	4.38	35.26	32.46	192	100	Peak	VERTICAL

Temperature	23°C	Humidity	56%
Test Engineer	Serway Li	Configurations	IEEE 802.11b CH 6 / Ant. 3
Test Date	Jun. 16, 2011		

Horizontal

	Freq	Level	Limit Line	Over Limit	Read Level	Cable Loss	Preamp Factor	Antenna Factor	T/Pos	A/Pos	Remark	Pol/Phase
	MHz	dBuV/m	dBuV/m	dB	dBuV	dB	dB	dB/m	deg	cm		
1 a	4873.89	32.55	54.00	-21.45	30.74	4.40	35.15	32.56	224	100	Average	HORIZONTAL
2 p	4874.02	42.95	74.00	-31.05	41.14	4.40	35.15	32.56	224	100	Peak	HORIZONTAL

Vertical

	Freq	Level	Limit Line	Over Limit	Read Level	Cable Loss	Preamp Factor	Antenna Factor	T/Pos	A/Pos	Remark	Pol/Phase
	MHz	dBuV/m	dBuV/m	dB	dBuV	dB	dB	dB/m	deg	cm		
1 p	4873.83	44.04	74.00	-29.96	42.23	4.40	35.15	32.56	194	103	Peak	VERTICAL
2 a	4874.03	33.39	54.00	-20.61	31.58	4.40	35.15	32.56	194	103	Average	VERTICAL

Temperature	23°C	Humidity	56%
Test Engineer	Serway Li	Configurations	IEEE 802.11b CH 11 / Ant. 3
Test Date	Jun. 16, 2011		

Horizontal

	Freq	Level	Limit Line	Over Limit	Read Level	Cable Loss	Preamp Factor	Antenna Factor	T/Pos	A/Pos	Remark	Pol/Phase
	MHz	dBuV/m	dBuV/m	dB	dBuV	dB	dB	dB/m	deg	cm		
1 p	4923.76	43.45	74.00	-30.55	41.40	4.42	35.03	32.66	232	100	Peak	HORIZONTAL
2 a	4924.84	30.62	54.00	-23.38	28.57	4.42	35.03	32.66	232	100	Average	HORIZONTAL

Vertical

	Freq	Level	Limit Line	Over Limit	Read Level	Cable Loss	Preamp Factor	Antenna Factor	T/Pos	A/Pos	Remark	Pol/Phase
	MHz	dBuV/m	dBuV/m	dB	dBuV	dB	dB	dB/m	deg	cm		
1 a	4924.30	33.20	54.00	-20.80	31.15	4.42	35.03	32.66	185	100	Average	VERTICAL
2 p	4924.96	44.43	74.00	-29.57	42.38	4.42	35.03	32.66	185	100	Peak	VERTICAL

Temperature	23°C	Humidity	56%
Test Engineer	Serway Li	Configurations	IEEE 802.11g CH 1 / Ant. 3
Test Date	Jun. 16, 2011		

Horizontal

	Freq	Level	Limit Line	Over Limit	Read Level	Cable Loss	Preamp Factor	Antenna Factor	T/Pos	A/Pos	Remark	Pol/Phase
	MHz	dBuV/m	dBuV/m	dB	dBuV	dB	dB	dB/m	deg	cm		
1 p	4824.05	42.82	74.00	-31.18	41.24	4.38	35.26	32.46	180	100	Peak	HORIZONTAL
2 a	4824.26	29.83	54.00	-24.17	28.25	4.38	35.26	32.46	180	100	Average	HORIZONTAL

Vertical

	Freq	Level	Limit Line	Over Limit	Read Level	Cable Loss	Preamp Factor	Antenna Factor	T/Pos	A/Pos	Remark	Pol/Phase
	MHz	dBuV/m	dBuV/m	dB	dBuV	dB	dB	dB/m	deg	cm		
1 p	4824.32	43.44	74.00	-30.56	41.86	4.38	35.26	32.46	291	100	Peak	VERTICAL
2 a	4824.33	32.69	54.00	-21.31	31.11	4.38	35.26	32.46	291	100	Average	VERTICAL

Temperature	23°C	Humidity	56%
Test Engineer	Serway Li	Configurations	IEEE 802.11g CH 6 / Ant. 3
Test Date	Jun. 16, 2011		

Horizontal

	Freq	Level	Limit Line	Over Limit	Read Level	Cable Loss	Preamp Factor	Antenna Factor	T/Pos	A/Pos	Remark	Pol/Phase
	MHz	dBuV/m	dBuV/m	dB	dBuV	dB	dB	dB/m	deg	cm		
1 a	4873.78	29.70	54.00	-24.30	27.89	4.40	35.15	32.56	211	100	Average	HORIZONTAL
2 p	4873.94	42.52	74.00	-31.48	40.71	4.40	35.15	32.56	211	100	Peak	HORIZONTAL

Vertical

	Freq	Level	Limit Line	Over Limit	Read Level	Cable Loss	Preamp Factor	Antenna Factor	T/Pos	A/Pos	Remark	Pol/Phase
	MHz	dBuV/m	dBuV/m	dB	dBuV	dB	dB	dB/m	deg	cm		
1 p	4873.52	44.58	74.00	-29.42	42.77	4.40	35.15	32.56	123	100	Peak	VERTICAL
2 a	4873.65	33.84	54.00	-20.16	32.03	4.40	35.15	32.56	123	100	Average	VERTICAL

Temperature	23°C	Humidity	56%
Test Engineer	Serway Li	Configurations	IEEE 802.11g CH 11 / Ant. 3
Test Date	Jun. 16, 2011		

Horizontal

	Freq	Level	Limit Line	Over Limit	Read Level	Cable Loss	Preamp Factor	Antenna Factor	T/Pos	A/Pos	Remark	Pol/Phase
	MHz	dBuV/m	dBuV/m	dB	dBuV	dB	dB	dB/m	deg	cm		
1 p	4923.73	43.57	74.00	-30.43	41.52	4.42	35.03	32.66	300	100	Peak	HORIZONTAL
2 a	4924.10	30.43	54.00	-23.57	28.38	4.42	35.03	32.66	300	100	Average	HORIZONTAL

Vertical

	Freq	Level	Limit Line	Over Limit	Read Level	Cable Loss	Preamp Factor	Antenna Factor	T/Pos	A/Pos	Remark	Pol/Phase
	MHz	dBuV/m	dBuV/m	dB	dBuV	dB	dB	dB/m	deg	cm		
1 a	4923.60	32.44	54.00	-21.56	30.39	4.42	35.03	32.66	223	100	Average	VERTICAL
2 p	4923.74	44.76	74.00	-29.24	42.71	4.42	35.03	32.66	223	100	Peak	VERTICAL

Note:

The amplitude of spurious emissions that are attenuated by more than 20dB below the permissible value has no need to be reported.

Emission level (dBuV/m) = 20 log Emission level (uV/m).

Corrected Reading: Antenna Factor + Cable Loss + Read Level - Preamp Factor = Level.

<For Ant. 4>

Temperature	23°C	Humidity	65%
Test Engineer	Serway Li	Configurations	IEEE 802.11n MCS0 20MHz Ch 1 / Ant. 4
Test Date	Jun. 15, 2011		

Horizontal

	Freq	Level	Limit	Over	Read	CableAntenna	Preamp	Remark	Pol/Phase	
	MHz	dBuV/m	dBuV/m	dB	dBuV	Loss	Factor	Factor		
						dB	dB/m	dB		
1	4822.12	31.06	54.00	-22.94	28.61	4.26	33.39	35.20	Average	HORIZONTAL
2	4824.32	43.93	74.00	-30.07	41.48	4.26	33.39	35.20	Peak	HORIZONTAL

Vertical

	Freq	Level	Limit	Over	Read	CableAntenna	Preamp	Remark	Pol/Phase	
	MHz	dBuV/m	dBuV/m	dB	dBuV	Loss	Factor	Factor		
						dB	dB/m	dB		
1	4821.24	31.11	54.00	-22.89	28.66	4.26	33.39	35.20	Average	VERTICAL
2	4821.28	43.84	74.00	-30.16	41.39	4.26	33.39	35.20	Peak	VERTICAL

Temperature	23°C	Humidity	65%
Test Engineer	Serway Li	Configurations	IEEE 802.11n MCS0 20MHz Ch 6 / Ant. 4
Test Date	Jun. 15, 2011		

Horizontal

	Freq	Level	Limit	Over	Read	CableAntenna	Preamp	Remark	Pol/Phase	
	MHz	dBuV/m	dBuV/m	dB	dBuV	Loss	Factor	Factor		
						dB	dB/m	dB		
1	4872.96	43.44	74.00	-30.56	40.83	4.33	33.48	35.20	Peak	HORIZONTAL
2	4876.30	30.94	54.00	-23.06	28.33	4.33	33.48	35.20	Average	HORIZONTAL

Vertical

	Freq	Level	Limit	Over	Read	CableAntenna	Preamp	Remark	Pol/Phase	
	MHz	dBuV/m	dBuV/m	dB	dBuV	Loss	Factor	Factor		
						dB	dB/m	dB		
1	4873.58	43.91	74.00	-30.09	41.30	4.33	33.48	35.20	Peak	VERTICAL
2	4875.58	31.07	54.00	-22.93	28.46	4.33	33.48	35.20	Average	VERTICAL

Temperature	23°C	Humidity	56%
Test Engineer	Serway Li	Configurations	IEEE 802.11n MCS0 20MHz Ch11 / Ant. 4
Test Date	Jun. 15, 2011		

Horizontal

	Freq	Level	Limit	Over	Read	CableAntenna	Preamp	Remark	Pol/Phase	
	MHz	dBuV/m	dBuV/m	dB	dBuV	Loss	Factor	Factor		
						dB	dB/m	dB		
1	4924.54	31.95	54.00	-22.05	29.18	4.39	33.58	35.20	Average	HORIZONTAL
2	4924.75	44.87	74.00	-29.13	42.10	4.39	33.58	35.20	Peak	HORIZONTAL

Vertical

	Freq	Level	Limit	Over	Read	CableAntenna	Preamp	Remark	Pol/Phase	
	MHz	dBuV/m	dBuV/m	dB	dBuV	Loss	Factor	Factor		
						dB	dB/m	dB		
1	4924.21	44.63	74.00	-29.37	41.86	4.39	33.58	35.20	Peak	VERTICAL
2	4924.27	32.02	54.00	-21.98	29.25	4.39	33.58	35.20	Average	VERTICAL

Temperature	23°C	Humidity	56%
Test Engineer	Serway Li	Configurations	IEEE 802.11n MCS0 40MHz Ch 3 / Ant. 4
Test Date	Jun. 15, 2011		

Horizontal

	Freq	Level	Limit	Over	Read	CableAntenna	Preamp	Remark	Pol/Phase	
	MHz	dBuV/m	dBuV/m	dB	dBuV	Loss	Factor	Factor		
						dB	dB/m	dB		
1	4846.10	43.63	74.00	-30.37	41.12	4.29	33.42	35.20	Peak	HORIZONTAL
2	4846.41	30.90	54.00	-23.10	28.39	4.29	33.42	35.20	Average	HORIZONTAL

Vertical

	Freq	Level	Limit	Over	Read	CableAntenna	Preamp	Remark	Pol/Phase	
	MHz	dBuV/m	dBuV/m	dB	dBuV	Loss	Factor	Factor		
						dB	dB/m	dB		
1	4842.12	30.93	54.00	-23.07	28.42	4.29	33.42	35.20	Average	VERTICAL
2	4845.15	43.80	74.00	-30.20	41.29	4.29	33.42	35.20	Peak	VERTICAL

Temperature	23°C	Humidity	56%
Test Engineer	Serway Li	Configurations	IEEE 802.11n MCS0 40MHz Ch 6 / Ant. 4
Test Date	Jun. 15, 2011		

Horizontal

	Freq	Level	Limit	Over	Read	CableAntenna	Preamp		
	MHz	dBuV/m	dBuV/m	dB	dBuV	Loss	Factor	Factor	Remark
						dB	dB/m	dB	
1	4875.33	43.73	74.00	-30.27	41.12	4.33	33.48	35.20	Peak
2	4876.32	30.98	54.00	-23.02	28.37	4.33	33.48	35.20	Average

Vertical

	Freq	Level	Limit	Over	Read	CableAntenna	Preamp		
	MHz	dBuV/m	dBuV/m	dB	dBuV	Loss	Factor	Factor	Remark
						dB	dB/m	dB	
1	4873.60	43.64	74.00	-30.36	41.03	4.33	33.48	35.20	Peak
2	4875.29	31.00	54.00	-23.00	28.39	4.33	33.48	35.20	Average

Temperature	23°C	Humidity	56%
Test Engineer	Serway Li	Configurations	IEEE 802.11n MCS0 40MHz Ch 9 / Ant. 4
Test Date	Jun. 15, 2011		

Horizontal

	Freq	Level	Limit	Over	Read	CableAntenna	Preamp	Remark	Pol/Phase	
	MHz	dBuV/m	dBuV/m	dB	dBuV	Loss Factor	Factor			
						dB	dB/m	dB		
1	4923.93	31.77	54.00	-22.23	29.00	4.39	33.58	35.20	Average	HORIZONTAL
2	4924.20	44.34	74.00	-29.66	41.57	4.39	33.58	35.20	Peak	HORIZONTAL

Vertical

	Freq	Level	Limit	Over	Read	CableAntenna	Preamp	Remark	Pol/Phase	
	MHz	dBuV/m	dBuV/m	dB	dBuV	Loss Factor	Factor			
						dB	dB/m	dB		
1	4922.74	31.93	54.00	-22.07	29.16	4.39	33.58	35.20	Average	VERTICAL
2	4924.95	44.52	74.00	-29.48	41.75	4.39	33.58	35.20	Peak	VERTICAL

Note:

The amplitude of spurious emissions which are attenuated by more than 20 dB below the permissible value has no need to be reported.

Emission level (dBuV/m) = 20 log Emission level (uV/m).

Corrected Reading: Antenna Factor + Cable Loss + Read Level - Preamp Factor = Level.

Temperature	23°C	Humidity	56%
Test Engineer	Serway Li	Configurations	IEEE 802.11b CH 1 / Ant. 4
Test Date	Jun. 15, 2011		

Horizontal

	Freq	Level	Limit	Over	Read	CableAntenna	Preamp	Remark	Pol/Phase	
	MHz	dBuV/m	dBuV/m	dB	dBuV	Loss	Factor	Factor		
						dB	dB/m	dB		
1	4823.69	43.84	74.00	-30.16	41.39	4.26	33.39	35.20	Peak	HORIZONTAL
2	4823.79	31.08	54.00	-22.92	28.63	4.26	33.39	35.20	Average	HORIZONTAL

Vertical

	Freq	Level	Limit	Over	Read	CableAntenna	Preamp	Remark	Pol/Phase	
	MHz	dBuV/m	dBuV/m	dB	dBuV	Loss	Factor	Factor		
						dB	dB/m	dB		
1	4823.94	35.86	54.00	-18.14	33.41	4.26	33.39	35.20	Average	VERTICAL
2	4824.01	46.35	74.00	-27.65	43.90	4.26	33.39	35.20	Peak	VERTICAL

Temperature	23°C	Humidity	56%
Test Engineer	Serway Li	Configurations	IEEE 802.11b CH 6 / Ant. 4
Test Date	Jun. 15, 2011		

Horizontal

	Freq	Level	Limit	Over	Read	CableAntenna	Preamp	Remark	Pol/Phase	
	MHz	dBuV/m	dBuV/m	dB	dBuV	Loss Factor	Factor			
						dB	dB/m	dB		
1	4873.93	35.70	54.00	-18.30	33.09	4.33	33.48	35.20	Average	HORIZONTAL
2	4873.96	45.31	74.00	-28.69	42.70	4.33	33.48	35.20	Peak	HORIZONTAL

Vertical

	Freq	Level	Limit	Over	Read	CableAntenna	Preamp	Remark	Pol/Phase	
	MHz	dBuV/m	dBuV/m	dB	dBuV	Loss Factor	Factor			
						dB	dB/m	dB		
1	4873.96	38.60	54.00	-15.40	35.99	4.33	33.48	35.20	Average	VERTICAL
2	4874.12	46.09	74.00	-27.91	43.48	4.33	33.48	35.20	Peak	VERTICAL

Temperature	23°C	Humidity	56%
Test Engineer	Serway Li	Configurations	IEEE 802.11b CH 11 / Ant. 4
Test Date	Jun. 15, 2011		

Horizontal

	Freq	Level	Limit	Over	Read	CableAntenna	Preamp	Remark	Pol/Phase	
	MHz	dBuV/m	dBuV/m	dB	dBuV	Loss	Factor	Factor		
						dB	dB/m	dB		
1	4923.94	37.64	54.00	-16.36	34.87	4.39	33.58	35.20	Average	HORIZONTAL
2	4923.94	49.33	74.00	-24.67	46.56	4.39	33.58	35.20	Peak	HORIZONTAL

Vertical

	Freq	Level	Limit	Over	Read	CableAntenna	Preamp	Remark	Pol/Phase	
	MHz	dBuV/m	dBuV/m	dB	dBuV	Loss	Factor	Factor		
						dB	dB/m	dB		
1	4923.94	42.37	54.00	-11.63	39.60	4.39	33.58	35.20	Average	VERTICAL
2	4924.09	51.13	74.00	-22.87	48.36	4.39	33.58	35.20	Peak	VERTICAL

Temperature	23°C	Humidity	56%
Test Engineer	Serway Li	Configurations	IEEE 802.11g CH 1 / Ant. 4
Test Date	Jun. 15, 2011		

Horizontal

	Freq	Level	Limit	Over	Read	CableAntenna	Preamp	Remark	Pol/Phase	
	MHz	dBuV/m	dBuV/m	dB	dBuV	Loss	Factor	Factor		
						dB	dB/m	dB		
1	4821.18	31.17	54.00	-22.83	28.72	4.26	33.39	35.20	Average	HORIZONTAL
2	4821.80	44.12	74.00	-29.88	41.67	4.26	33.39	35.20	Peak	HORIZONTAL

Vertical

	Freq	Level	Limit	Over	Read	CableAntenna	Preamp	Remark	Pol/Phase	
	MHz	dBuV/m	dBuV/m	dB	dBuV	Loss	Factor	Factor		
						dB	dB/m	dB		
1	4822.40	31.34	54.00	-22.66	28.89	4.26	33.39	35.20	Average	VERTICAL
2	4823.88	43.75	74.00	-30.25	41.30	4.26	33.39	35.20	Peak	VERTICAL

Temperature	23°C	Humidity	56%
Test Engineer	Serway Li	Configurations	IEEE 802.11g CH 6 / Ant. 4
Test Date	Jun. 15, 2011		

Horizontal

	Freq	Level	Limit	Over	Read	CableAntenna	Preamp	Remark	Pol/Phase	
	MHz	dBuV/m	dBuV/m	dB	dBuV	Loss	Factor	Factor		
						dB	dB/m	dB		
1	4874.52	43.00	74.00	-31.00	40.39	4.33	33.48	35.20	Peak	HORIZONTAL
2	4875.36	31.05	54.00	-22.95	28.44	4.33	33.48	35.20	Average	HORIZONTAL

Vertical

	Freq	Level	Limit	Over	Read	CableAntenna	Preamp	Remark	Pol/Phase	
	MHz	dBuV/m	dBuV/m	dB	dBuV	Loss	Factor	Factor		
						dB	dB/m	dB		
1	4877.80	43.88	74.00	-30.12	41.27	4.33	33.48	35.20	Peak	VERTICAL
2	4878.16	31.18	54.00	-22.82	28.57	4.33	33.48	35.20	Average	VERTICAL

Temperature	23°C	Humidity	56%
Test Engineer	Serway Li	Configurations	IEEE 802.11g CH 11 / Ant. 4
Test Date	Jun. 15, 2011		

Horizontal

	Freq	Level	Limit	Over	Read	CableAntenna	Preamp	Remark	Pol/Phase	
	MHz	dBuV/m	dBuV/m	dB	dBuV	dB	dB/m	dB		
1	4922.74	44.08	74.00	-29.92	41.31	4.39	33.58	35.20	Peak	HORIZONTAL
2	4923.22	31.92	54.00	-22.08	29.15	4.39	33.58	35.20	Average	HORIZONTAL

Vertical

	Freq	Level	Limit	Over	Read	CableAntenna	Preamp	Remark	Pol/Phase	
	MHz	dBuV/m	dBuV/m	dB	dBuV	dB	dB/m	dB		
1	4920.46	45.00	74.00	-29.00	42.27	4.39	33.54	35.20	Peak	VERTICAL
2	4922.10	31.81	54.00	-22.19	29.04	4.39	33.58	35.20	Average	VERTICAL

Note:

The amplitude of spurious emissions that are attenuated by more than 20dB below the permissible value has no need to be reported.

Emission level (dBuV/m) = 20 log Emission level (uV/m).

Corrected Reading: Antenna Factor + Cable Loss + Read Level - Preamp Factor = Level.

<For Ant. 5>

Temperature	20°C	Humidity	63%
Test Engineer	Serway Li	Configurations	IEEE 802.11n MCS0 20MHz Ch 1 / Ant. 5
Test Date	Jul. 30, 2011		

Horizontal

	Freq	Level	Limit	Over	Read	Cable	Preamp	Antenna	T/Pos	A/Pos	Remark	Pol/Phase
	MHz	dBuV/m	dBuV/m	dB	dBuV	dB	dB	dB/m	deg	cm		
1 a	4819.18	30.81	54.00	-23.19	29.23	4.38	35.26	32.46	42	100	Average	HORIZONTAL
2 p	4820.52	43.52	74.00	-30.48	41.94	4.38	35.26	32.46	42	100	Peak	HORIZONTAL

Vertical

	Freq	Level	Limit	Over	Read	Cable	Preamp	Antenna	T/Pos	A/Pos	Remark	Pol/Phase
	MHz	dBuV/m	dBuV/m	dB	dBuV	dB	dB	dB/m	deg	cm		
1 a	4819.24	30.82	54.00	-23.18	29.24	4.38	35.26	32.46	227	100	Average	VERTICAL
2 p	4822.08	43.21	74.00	-30.79	41.63	4.38	35.26	32.46	227	100	Peak	VERTICAL

Temperature	20°C	Humidity	63%
Test Engineer	Serway Li	Configurations	IEEE 802.11n MCS0 20MHz Ch 6 / Ant. 5
Test Date	Jul. 30, 2011		

Horizontal

	Freq	Level	Limit Line	Over Limit	Read Level	Cable Loss	Preamp Factor	Antenna Factor	T/Pos	A/Pos	Remark	Pol/Phase
	MHz	dBuV/m	dBuV/m	dB	dBuV	dB	dB	dB/m	deg	cm		
1 a	4875.08	30.91	54.00	-23.09	29.10	4.40	35.15	32.56	196	100	Average	HORIZONTAL
2 p	4877.40	43.13	74.00	-30.87	41.32	4.40	35.15	32.56	196	100	Peak	HORIZONTAL

Vertical

	Freq	Level	Limit Line	Over Limit	Read Level	Cable Loss	Preamp Factor	Antenna Factor	T/Pos	A/Pos	Remark	Pol/Phase
	MHz	dBuV/m	dBuV/m	dB	dBuV	dB	dB	dB/m	deg	cm		
1 p	4874.30	43.52	74.00	-30.48	41.71	4.40	35.15	32.56	38	100	Peak	VERTICAL
2 a	4875.30	30.58	54.00	-23.42	28.77	4.40	35.15	32.56	38	100	Average	VERTICAL

Temperature	20°C	Humidity	63%
Test Engineer	Serway Li	Configurations	IEEE 802.11n MCS0 20MHz Ch11 / Ant. 5
Test Date	Jul. 30, 2011		

Horizontal

	Freq	Level	Limit Line	Over Limit	Read Level	Cable Loss	Preamp Factor	Antenna Factor	T/Pos	A/Pos	Remark	Pol/Phase
	MHz	dBuV/m	dBuV/m	dB	dBuV	dB	dB	dB/m	deg	cm		
1 p	4926.56	43.44	74.00	-30.56	41.39	4.42	35.03	32.66	151	100	Peak	HORIZONTAL
2 a	4928.00	31.34	54.00	-22.66	29.29	4.42	35.03	32.66	151	100	Average	HORIZONTAL

Vertical

	Freq	Level	Limit Line	Over Limit	Read Level	Cable Loss	Preamp Factor	Antenna Factor	T/Pos	A/Pos	Remark	Pol/Phase
	MHz	dBuV/m	dBuV/m	dB	dBuV	dB	dB	dB/m	deg	cm		
1 p	4921.02	44.49	74.00	-29.51	42.44	4.42	35.03	32.66	57	100	Peak	VERTICAL
2 a	4923.70	31.35	54.00	-22.65	29.30	4.42	35.03	32.66	57	100	Average	VERTICAL

Temperature	20°C	Humidity	63%
Test Engineer	Serway Li	Configurations	IEEE 802.11n MCS0 40MHz Ch 3 / Ant. 5
Test Date	Jul. 30, 2011		

Horizontal

	Freq	Level	Limit	Over	Read	Cable	Preamp	Antenna	T/Pos	A/Pos	Remark	Pol/Phase
	MHz	dBuV/m	dBuV/m	dB	dBuV	dB	dB	dB/m	deg	cm		
1 p	4844.97	44.03	74.00	-29.97	42.35	4.39	35.20	32.49	44	100	Peak	HORIZONTAL
2 a	4845.72	30.78	54.00	-23.22	29.10	4.39	35.20	32.49	44	100	Average	HORIZONTAL

Vertical

	Freq	Level	Limit	Over	Read	Cable	Preamp	Antenna	T/Pos	A/Pos	Remark	Pol/Phase
	MHz	dBuV/m	dBuV/m	dB	dBuV	dB	dB	dB/m	deg	cm		
1 a	4843.18	30.84	54.00	-23.16	29.16	4.39	35.20	32.49	192	100	Average	VERTICAL
2 p	4843.72	43.09	74.00	-30.91	41.41	4.39	35.20	32.49	192	100	Peak	VERTICAL

Temperature	20°C	Humidity	63%
Test Engineer	Serway Li	Configurations	IEEE 802.11n MCS0 40MHz Ch 6 / Ant. 5
Test Date	Jul. 30, 2011		

Horizontal

	Freq	Level	Limit	Over	Read	Cable	Preamp	Antenna	T/Pos	A/Pos	Remark	Pol/Phase
	MHz	dBuV/m	dBuV/m	dB	dBuV	dB	dB	dB/m	deg	cm		
1 a	4872.25	30.65	54.00	-23.35	28.84	4.40	35.15	32.56	294	100	Average	HORIZONTAL
2 p	4873.63	43.63	74.00	-30.37	41.82	4.40	35.15	32.56	294	100	Peak	HORIZONTAL

Vertical

	Freq	Level	Limit	Over	Read	Cable	Preamp	Antenna	T/Pos	A/Pos	Remark	Pol/Phase
	MHz	dBuV/m	dBuV/m	dB	dBuV	dB	dB	dB/m	deg	cm		
1 p	4874.61	44.02	74.00	-29.98	42.21	4.40	35.15	32.56	176	100	Peak	VERTICAL
2 a	4875.66	30.61	54.00	-23.39	28.80	4.40	35.15	32.56	176	100	Average	VERTICAL

Temperature	20°C	Humidity	63%
Test Engineer	Serway Li	Configurations	IEEE 802.11n MCS0 40MHz Ch 9 / Ant. 5
Test Date	Jul. 30, 2011		

Horizontal

	Freq	Level	Limit	Over	Read	Cable	Preamp	Antenna	T/Pos	A/Pos	Remark	Pol/Phase
	MHz	dBuV/m	dBuV/m	dB	dBuV	dB	dB	dB/m	deg	cm		
1 a	4904.47	31.14	54.00	-22.86	29.19	4.41	35.09	32.63	100	100	Average	HORIZONTAL
2 p	4904.58	44.61	74.00	-29.39	42.66	4.41	35.09	32.63	100	100	Peak	HORIZONTAL

Vertical

	Freq	Level	Limit	Over	Read	Cable	Preamp	Antenna	T/Pos	A/Pos	Remark	Pol/Phase
	MHz	dBuV/m	dBuV/m	dB	dBuV	dB	dB	dB/m	deg	cm		
1 p	4901.57	43.86	74.00	-30.14	41.91	4.41	35.09	32.63	222	100	Peak	VERTICAL
2 a	4903.90	31.13	54.00	-22.87	29.18	4.41	35.09	32.63	222	100	Average	VERTICAL

Note:

The amplitude of spurious emissions which are attenuated by more than 20 dB below the permissible value has no need to be reported.

Emission level (dBuV/m) = 20 log Emission level (uV/m).

Corrected Reading: Antenna Factor + Cable Loss + Read Level - Preamp Factor = Level.

Temperature	20°C	Humidity	63%
Test Engineer	Serway Li	Configurations	IEEE 802.11b CH 1 / Ant. 5
Test Date	Jul. 30, 2011		

Horizontal

	Freq	Level	Limit Line	Over Limit	Read Level	Cable Loss	Preamp Factor	Antenna Factor	T/Pos	A/Pos	Remark	Pol/Phase
	MHz	dBuV/m	dBuV/m	dB	dBuV	dB	dB	dB/m	deg	cm		
1 a	4824.20	29.99	54.00	-24.01	28.41	4.38	35.26	32.46	125	100	Average	HORIZONTAL
2 p	4825.08	43.67	74.00	-30.33	42.09	4.38	35.26	32.46	125	100	Peak	HORIZONTAL

Vertical

	Freq	Level	Limit Line	Over Limit	Read Level	Cable Loss	Preamp Factor	Antenna Factor	T/Pos	A/Pos	Remark	Pol/Phase
	MHz	dBuV/m	dBuV/m	dB	dBuV	dB	dB	dB/m	deg	cm		
1 a	4823.85	35.46	54.00	-18.54	33.88	4.38	35.26	32.46	74	110	Average	VERTICAL
2 p	4824.01	46.10	74.00	-27.90	44.52	4.38	35.26	32.46	74	110	Peak	VERTICAL

Temperature	20°C	Humidity	63%
Test Engineer	Serway Li	Configurations	IEEE 802.11b CH 6 / Ant. 5
Test Date	Jul. 30, 2011		

Horizontal

	Freq	Level	Limit	Over	Read	Cable	Preamp	Antenna	T/Pos	A/Pos	Remark	Pol/Phase
	MHz	dBuV/m	dBuV/m	dB	dBuV	dB	dB	dB/m	deg	cm		
1 a	4873.96	31.02	54.00	-22.98	29.21	4.40	35.15	32.56	256	100	Average	HORIZONTAL
2 p	4878.20	43.31	74.00	-30.69	41.50	4.40	35.15	32.56	256	100	Peak	HORIZONTAL

Vertical

	Freq	Level	Limit	Over	Read	Cable	Preamp	Antenna	T/Pos	A/Pos	Remark	Pol/Phase
	MHz	dBuV/m	dBuV/m	dB	dBuV	dB	dB	dB/m	deg	cm		
1 p	4867.20	43.33	74.00	-30.67	41.56	4.40	35.15	32.52	9	100	Peak	VERTICAL
2 a	4873.92	33.87	54.00	-20.13	32.06	4.40	35.15	32.56	9	100	Average	VERTICAL

Temperature	20°C	Humidity	63%
Test Engineer	Serway Li	Configurations	IEEE 802.11b CH 11 / Ant. 5
Test Date	Jul. 30, 2011		

Horizontal

	Freq	Level	Limit	Over	Read	Cable	Preamp	Antenna	T/Pos	A/Pos	Remark	Pol/Phase
	MHz	dBuV/m	dBuV/m	dB	dBuV	dB	dB	dB/m	deg	cm		
1 a	4923.80	32.72	54.00	-21.28	30.67	4.42	35.03	32.66	62	100	Average	HORIZONTAL
2 p	4927.88	43.69	74.00	-30.31	41.64	4.42	35.03	32.66	62	100	Peak	HORIZONTAL

Vertical

	Freq	Level	Limit	Over	Read	Cable	Preamp	Antenna	T/Pos	A/Pos	Remark	Pol/Phase
	MHz	dBuV/m	dBuV/m	dB	dBuV	dB	dB	dB/m	deg	cm		
1 p	4919.12	44.22	74.00	-29.78	42.17	4.42	35.03	32.66	271	100	Peak	VERTICAL
2 a	4923.92	31.42	54.00	-22.58	29.37	4.42	35.03	32.66	271	100	Average	VERTICAL

Temperature	20°C	Humidity	63%
Test Engineer	Serway Li	Configurations	IEEE 802.11g CH 1 / Ant. 5
Test Date	Jul. 30, 2011		

Horizontal

	Freq	Level	Limit Line	Over Limit	Read Level	Cable Loss	Preamp Factor	Antenna Factor	T/Pos	A/Pos	Remark	Pol/Phase
	MHz	dBuV/m	dBuV/m	dB	dBuV	dB	dB	dB/m	deg	cm		
1 a	4819.24	30.86	54.00	-23.14	29.28	4.38	35.26	32.46	153	100	Average	HORIZONTAL
2 p	4827.38	43.41	74.00	-30.59	41.83	4.38	35.26	32.46	153	100	Peak	HORIZONTAL

Vertical

	Freq	Level	Limit Line	Over Limit	Read Level	Cable Loss	Preamp Factor	Antenna Factor	T/Pos	A/Pos	Remark	Pol/Phase
	MHz	dBuV/m	dBuV/m	dB	dBuV	dB	dB	dB/m	deg	cm		
1 p	4821.10	43.49	74.00	-30.51	41.91	4.38	35.26	32.46	268	100	Peak	VERTICAL
2 a	4821.82	30.85	54.00	-23.15	29.27	4.38	35.26	32.46	268	100	Average	VERTICAL

Temperature	20°C	Humidity	63%
Test Engineer	Serway Li	Configurations	IEEE 802.11g CH 6 / Ant. 5
Test Date	Jul. 30, 2011		

Horizontal

	Freq	Level	Limit Line	Over Limit	Read Level	Cable Loss	Preamp Factor	Antenna Factor	T/Pos	A/Pos	Remark	Pol/Phase
	MHz	dBuV/m	dBuV/m	dB	dBuV	dB	dB	dB/m	deg	cm		
1 p	4872.24	44.18	74.00	-29.82	42.37	4.40	35.15	32.56	114	100	Peak	HORIZONTAL
2 a	4878.08	30.56	54.00	-23.44	28.75	4.40	35.15	32.56	114	100	Average	HORIZONTAL

Vertical

	Freq	Level	Limit Line	Over Limit	Read Level	Cable Loss	Preamp Factor	Antenna Factor	T/Pos	A/Pos	Remark	Pol/Phase
	MHz	dBuV/m	dBuV/m	dB	dBuV	dB	dB	dB/m	deg	cm		
1 a	4876.16	30.81	54.00	-23.19	29.00	4.40	35.15	32.56	206	100	Average	VERTICAL
2 p	4877.26	43.30	74.00	-30.70	41.49	4.40	35.15	32.56	206	100	Peak	VERTICAL

Temperature	20°C	Humidity	63%
Test Engineer	Serway Li	Configurations	IEEE 802.11g CH 11 / Ant. 5
Test Date	Jul. 30, 2011		

Horizontal

	Freq	Level	Limit Line	Over Limit	Read Level	Cable Loss	Preamp Factor	Antenna Factor	T/Pos	A/Pos	Remark	Pol/Phase
	MHz	dBuV/m	dBuV/m	dB	dBuV	dB	dB	dB/m	deg	cm		
1 p	4922.98	43.80	74.00	-30.20	41.75	4.42	35.03	32.66	103	100	Peak	HORIZONTAL
2 a	4928.46	31.03	54.00	-22.97	28.98	4.42	35.03	32.66	103	100	Average	HORIZONTAL

Vertical

	Freq	Level	Limit Line	Over Limit	Read Level	Cable Loss	Preamp Factor	Antenna Factor	T/Pos	A/Pos	Remark	Pol/Phase
	MHz	dBuV/m	dBuV/m	dB	dBuV	dB	dB	dB/m	deg	cm		
1 p	4925.96	44.12	74.00	-29.88	42.07	4.42	35.03	32.66	244	100	Peak	VERTICAL
2 a	4927.58	31.09	54.00	-22.91	29.04	4.42	35.03	32.66	244	100	Average	VERTICAL

Note:

The amplitude of spurious emissions that are attenuated by more than 20dB below the permissible value has no need to be reported.

Emission level (dBuV/m) = 20 log Emission level (uV/m).

Corrected Reading: Antenna Factor + Cable Loss + Read Level - Preamp Factor = Level.

4.6. Band Edge Emissions Measurement

4.6.1. Limit

20dBc in any 100 kHz bandwidth outside the operating frequency band. In case the emission fall within the restricted band specified on 15.205(a), then the 15.209(a) limit in the table below has to be followed.

Frequencies (MHz)	Field Strength (micovolts/meter)	Measurement Distance (meters)
0.009~0.490	2400/F(KHz)	300
0.490~1.705	24000/F(KHz)	30
1.705~30.0	30	30
30~88	100	3
88~216	150	3
216~960	200	3
Above 960	500	3

4.6.2. Measuring Instruments and Setting

Please refer to section 5 of equipments list in this report. The following table is the setting of the spectrum analyzer.

Spectrum Parameter	Setting
Attenuation	Auto
Span Frequency	100 MHz
RB / VB (Emission in restricted band)	1 MHz / 1MHz for Peak, 1 MHz / 10Hz for Average
RB / VB (Emission in non-restricted band)	100 KHz /100 KHz for Peak

4.6.3. Test Procedures

1. The test procedure is the same as section 4.5.3, only the frequency range investigated is limited to 100MHz around bandedges.
2. In case the emission is fail due to the used RB/VB is too wide, marker-delta method of FCC Public Notice DA00-705 will be followed.

4.6.4. Test Setup Layout

This test setup layout is the same as that shown in section 4.5.4.

4.6.5. Test Deviation

There is no deviation with the original standard.

4.6.6. EUT Operation during Test

The EUT was programmed to be in continuously transmitting mode.

4.6.7. Test Result of Band Edge and Fundamental Emissions

<For Ant. 1 >

Temperature	23°C	Humidity	56%
Test Engineer	Serway Li	Configurations	IEEE 802.11n MCS0 20MHz Ch 1, 6, 11 / Ant. 1
Test Date	Jun. 16, 2011		

Channel 1

	Freq	Level	Limit Line	Over Limit	Read Level	CableAntenna Loss	Antenna Factor	Preamp Factor	T/Pos	A/Pos	Remark	Pol/Phase
	MHz	dBuV/m	dBuV/m	dB	dBuV	dB	dB/m	dB	deg	cm		
1	2389.00	71.57	74.00	-2.43	41.19	2.21	28.17	0.00	358	136	Peak	VERTICAL
2	2390.00	53.46	54.00	-0.54	23.07	2.22	28.17	0.00	358	136	Average	VERTICAL
3	2409.40	102.29				2.22	28.21	0.00	358	136	Average	VERTICAL
4	2413.60	112.98				2.22	28.21	0.00	358	136	Peak	VERTICAL

Item 3, 4 are the fundamental frequency at 2412 MHz.

Channel 6

	Freq	Level	Limit Line	Over Limit	Read Level	CableAntenna Loss	Antenna Factor	Preamp Factor	T/Pos	A/Pos	Remark	Pol/Phase
	MHz	dBuV/m	dBuV/m	dB	dBuV	dB	dB/m	dB	deg	cm		
1	2390.00	52.40	54.00	-1.60	22.01	2.22	28.17	0.00	350	135	Average	VERTICAL
2	2390.00	60.45	74.00	-13.55	30.06	2.22	28.17	0.00	350	135	Peak	VERTICAL
3	2430.00	107.92				2.23	28.25	0.00	350	135	Average	VERTICAL
4	2431.20	116.52				2.23	28.25	0.00	350	135	Peak	VERTICAL
5	2483.50	53.09	54.00	-0.91	22.46	2.26	28.37	0.00	350	135	Average	VERTICAL
6	2483.50	61.22	74.00	-12.78	30.59	2.26	28.37	0.00	350	135	Peak	VERTICAL

Item 3, 4 are the fundamental frequency at 2437MHz.

Channel 11

	Freq	Level	Limit Line	Over Limit	Read Level	CableAntenna Loss	Antenna Factor	Preamp Factor	T/Pos	A/Pos	Remark	Pol/Phase
	MHz	dBuV/m	dBuV/m	dB	dBuV	dB	dB/m	dB	deg	cm		
1	2468.80	113.12				2.26	28.37	0.00	356	177	Peak	VERTICAL
2	2469.00	102.85				2.26	28.37	0.00	356	177	Average	VERTICAL
3	2483.50	53.17	54.00	-0.83	22.54	2.26	28.37	0.00	356	177	Average	VERTICAL
4	2483.50	66.74	74.00	-7.26	36.11	2.26	28.37	0.00	356	177	Peak	VERTICAL

Item 1, 2 are the fundamental frequency at 2462 MHz.

Temperature	23°C	Humidity	56%
Test Engineer	Serway Li	Configurations	IEEE 802.11n MCS0 40MHz Ch 3, 6, 9 / Ant. 1
Test Date	Jun. 16, 2011		

Channel 3

	Freq	Level	Limit Line	Over Limit	Read Level	Cable Loss	Antenna Factor	Preamp Factor	T/Pos	A/Pos	Remark	Pol/Phase
	MHz	dBuV/m	dBuV/m	dB	dBuV	dB	dB/m	dB	deg	cm		
1	2390.00	53.14	54.00	-0.86	22.75	2.22	28.17	0.00	358	110	Average	VERTICAL
2	2390.00	68.33	74.00	-5.67	37.94	2.22	28.17	0.00	358	110	Peak	VERTICAL
3	2412.00	107.76				2.22	28.21	0.00	358	110	Peak	VERTICAL
4	2413.20	96.49				2.22	28.21	0.00	358	110	Average	VERTICAL

Item 3, 4 are the fundamental frequency at 2422 MHz.

Channel 6

	Freq	Level	Limit Line	Over Limit	Read Level	Cable Loss	Antenna Factor	Preamp Factor	T/Pos	A/Pos	Remark	Pol/Phase
	MHz	dBuV/m	dBuV/m	dB	dBuV	dB	dB/m	dB	deg	cm		
1	2390.00	52.69	54.00	-1.31	22.30	2.22	28.17	0.00	359	169	Average	VERTICAL
2	2390.00	67.06	74.00	-6.94	36.67	2.22	28.17	0.00	359	169	Peak	VERTICAL
3	2420.60	99.28				2.23	28.25	0.00	359	169	Average	VERTICAL
4	2423.80	109.68				2.23	28.25	0.00	359	169	Peak	VERTICAL
5	2483.50	53.33	54.00	-0.67	22.70	2.26	28.37	0.00	359	169	Average	VERTICAL
6	2483.90	66.76	74.00	-7.24	36.13	2.26	28.37	0.00	359	169	Peak	VERTICAL

Item 3, 4 are the fundamental frequency at 2437MHz.

Channel 9

	Freq	Level	Limit Line	Over Limit	Read Level	Cable Loss	Antenna Factor	Preamp Factor	T/Pos	A/Pos	Remark	Pol/Phase
	MHz	dBuV/m	dBuV/m	dB	dBuV	dB	dB/m	dB	deg	cm		
1	2467.20	107.83				2.26	28.33	0.00	2	168	Peak	VERTICAL
2	2468.00	97.64				2.26	28.33	0.00	2	168	Average	VERTICAL
3	2483.50	53.24	54.00	-0.76	22.61	2.26	28.37	0.00	2	168	Average	VERTICAL
4	2483.50	69.03	74.00	-4.97	38.40	2.26	28.37	0.00	2	168	Peak	VERTICAL

Item 1, 2 are the fundamental frequency at 2452 MHz.

Note:

Emission level (dBuV/m) = 20 log Emission level (uV/m).

Corrected Reading: Antenna Factor + Cable Loss + Read Level - Preamp Factor = Level.

Temperature	23°C	Humidity	56%
Test Engineer	Serway Li	Configurations	IEEE 802.11b CH 1, 6, 11 / Ant. 1
Test Date	Jun. 16, 2011		

Channel 1

	Freq	Level	Limit Line	Over Limit	Read Level	Cable Loss	Antenna Factor	Preamp Factor	T/Pos	A/Pos	Remark	Pol/Phase
	MHz	dBuV/m	dBuV/m	dB	dBuV	dB	dB/m	dB	deg	cm		
1	2390.00	53.13	54.00	-0.87	22.74	2.22	28.17	0.00	356	110	Average	VERTICAL
2	2390.00	61.80	74.00	-12.20	31.41	2.22	28.17	0.00	356	110	Peak	VERTICAL
3	2410.40	111.76				2.22	28.21	0.00	356	110	Average	VERTICAL
4	2411.20	114.60				2.22	28.21	0.00	356	110	Peak	VERTICAL

Item 3, 4 are the fundamental frequency at 2412 MHz.

Channel 6

	Freq	Level	Limit Line	Over Limit	Read Level	Cable Loss	Antenna Factor	Preamp Factor	T/Pos	A/Pos	Remark	Pol/Phase
	MHz	dBuV/m	dBuV/m	dB	dBuV	dB	dB/m	dB	deg	cm		
1	2390.00	52.44	54.00	-1.56	22.05	2.22	28.17	0.00	358	171	Average	VERTICAL
2	2390.00	63.03	74.00	-10.97	32.64	2.22	28.17	0.00	358	171	Peak	VERTICAL
3	2435.20	115.08				2.23	28.29	0.00	358	171	Average	VERTICAL
4	2436.20	118.54				2.23	28.29	0.00	358	171	Peak	VERTICAL
5	2483.50	65.50	74.00	-8.50	34.87	2.26	28.37	0.00	358	171	Peak	VERTICAL
6	2483.70	53.65	54.00	-0.35	23.02	2.26	28.37	0.00	358	171	Average	VERTICAL

Item 3, 4 are the fundamental frequency at 2437MHz.

Channel 11

	Freq	Level	Limit Line	Over Limit	Read Level	Cable Loss	Antenna Factor	Preamp Factor	T/Pos	A/Pos	Remark	Pol/Phase
	MHz	dBuV/m	dBuV/m	dB	dBuV	dB	dB/m	dB	deg	cm		
1	2464.60	115.35				2.24	28.33	0.00	354	167	Peak	VERTICAL
2	2464.80	111.93				2.24	28.33	0.00	354	167	Average	VERTICAL
3	2483.50	53.15	54.00	-0.85	22.52	2.26	28.37	0.00	354	167	Average	VERTICAL
4	2483.50	63.94	74.00	-10.06	33.31	2.26	28.37	0.00	354	167	Peak	VERTICAL

Item 1, 2 are the fundamental frequency at 2462 MHz.

Temperature	23°C	Humidity	56%
Test Engineer	Serway Li	Configurations	IEEE 802.11g CH 1, 6, 11 / Ant. 1
Test Date	Jun. 16, 2011		

Channel 1

	Freq	Level	Limit Line	Over Limit	Read Level	Cable Loss	Antenna Factor	Preamp Factor	T/Pos	A/Pos	Remark	Pol/Phase
	MHz	dBuV/m	dBuV/m	dB	dBuV	dB	dB/m	dB	deg	cm		
1	2389.60	69.60	74.00	-4.40	39.22	2.21	28.17	0.00	358	136	Peak	VERTICAL
2	2390.00	53.35	54.00	-0.65	22.96	2.22	28.17	0.00	358	136	Average	VERTICAL
3	2406.40	103.26				2.22	28.21	0.00	358	136	Average	VERTICAL
4	2409.80	113.25				2.22	28.21	0.00	358	136	Peak	VERTICAL

Item 3, 4 are the fundamental frequency at 2412 MHz.

Channel 6

	Freq	Level	Limit Line	Over Limit	Read Level	Cable Loss	Antenna Factor	Preamp Factor	T/Pos	A/Pos	Remark	Pol/Phase
	MHz	dBuV/m	dBuV/m	dB	dBuV	dB	dB/m	dB	deg	cm		
1	2390.00	51.84	54.00	-2.16	21.45	2.22	28.17	0.00	353	167	Average	VERTICAL
2	2390.00	60.86	74.00	-13.14	30.47	2.22	28.17	0.00	353	167	Peak	VERTICAL
3	2430.00	116.57				2.23	28.25	0.00	353	167	Peak	VERTICAL
4	2430.40	108.83				2.23	28.25	0.00	353	167	Average	VERTICAL
5	2483.50	53.27	54.00	-0.73	22.64	2.26	28.37	0.00	353	167	Average	VERTICAL
6	2483.50	62.98	74.00	-11.02	32.35	2.26	28.37	0.00	353	167	Peak	VERTICAL

Item 3, 4 are the fundamental frequency at 2437 MHz.

Channel 11

	Freq	Level	Limit Line	Over Limit	Read Level	Cable Loss	Antenna Factor	Preamp Factor	T/Pos	A/Pos	Remark	Pol/Phase
	MHz	dBuV/m	dBuV/m	dB	dBuV	dB	dB/m	dB	deg	cm		
1	2468.20	104.10				2.26	28.37	0.00	350	173	Average	VERTICAL
2	2468.80	113.75				2.26	28.37	0.00	350	173	Peak	VERTICAL
3	2483.50	53.15	54.00	-0.85	22.52	2.26	28.37	0.00	350	173	Average	VERTICAL
4	2483.50	66.19	74.00	-7.81	35.56	2.26	28.37	0.00	350	173	Peak	VERTICAL

Item 1, 2 are the fundamental frequency at 2462 MHz.

Note:

Emission level (dBuV/m) = 20 log Emission level (uV/m).

Corrected Reading: Antenna Factor + Cable Loss + Read Level - Preamp Factor = Level.

<For Ant. 2>

Temperature	23°C	Humidity	56%
Test Engineer	Serway Li	Configurations	IEEE 802.11n MCS0 20MHz Ch 1, 6, 11 / Ant. 2
Test Date	Jun. 13, 2011		

Channel 1

	Freq	Level	Limit Line	Over Limit	Read Level	CableAntenna Loss	Antenna Factor	Preamp Factor	T/Pos	A/Pos	Remark	Pol/Phase
	MHz	dBuV/m	dBuV/m	dB	dBuV	dB	dB/m	dB	deg	cm		
1	2389.52	68.59	74.00	-5.41	38.21	2.21	28.17	0.00	223	99	Peak	VERTICAL
2	2390.00	53.85	54.00	-0.15	23.46	2.22	28.17	0.00	223	99	Average	VERTICAL
3	2406.55	112.22				2.22	28.21	0.00	223	99	Peak	VERTICAL
4	2406.71	102.27				2.22	28.21	0.00	223	99	Average	VERTICAL

Item 3, 4 are the fundamental frequency at 2412 MHz.

Channel 6

	Freq	Level	Limit Line	Over Limit	Read Level	CableAntenna Loss	Antenna Factor	Preamp Factor	T/Pos	A/Pos	Remark	Pol/Phase
	MHz	dBuV/m	dBuV/m	dB	dBuV	dB	dB/m	dB	deg	cm		
1	2389.20	67.54	74.00	-6.46	37.16	2.21	28.17	0.00	93	127	Peak	VERTICAL
2	2390.00	50.11	54.00	-3.89	19.72	2.22	28.17	0.00	93	127	Average	VERTICAL
3	2429.79	106.96				2.23	28.25	0.00	93	127	Average	VERTICAL
4	2432.03	117.05				2.23	28.25	0.00	93	127	Peak	VERTICAL
5	2483.50	51.23	54.00	-2.77	20.60	2.26	28.37	0.00	93	127	Average	VERTICAL
6	2484.46	65.86	74.00	-8.14	35.23	2.26	28.37	0.00	93	127	Peak	VERTICAL

Item 3, 4 are the fundamental frequency at 2437MHz.

Channel 11

	Freq	Level	Limit Line	Over Limit	Read Level	CableAntenna Loss	Antenna Factor	Preamp Factor	T/Pos	A/Pos	Remark	Pol/Phase
	MHz	dBuV/m	dBuV/m	dB	dBuV	dB	dB/m	dB	deg	cm		
1	2466.01	113.30				2.24	28.33	0.00	95	124	Peak	VERTICAL
2	2469.21	103.61				2.26	28.37	0.00	95	124	Average	VERTICAL
3	2483.50	53.74	54.00	-0.26	23.11	2.26	28.37	0.00	95	124	Average	VERTICAL
4	2483.66	69.88	74.00	-4.12	39.25	2.26	28.37	0.00	95	124	Peak	VERTICAL

Item 1, 2 are the fundamental frequency at 2462 MHz.

Temperature	23°C	Humidity	56%
Test Engineer	Serway Li	Configurations	IEEE 802.11n MCS0 40MHz Ch 3, 6, 9 / Ant. 2
Test Date	Jun. 13, 2011		

Channel 3

	Freq	Level	Limit Line	Over Limit	Read Level	CableAntenna Loss	Preamp Factor	T/Pos	A/Pos	Remark	Pol/Phase
	MHz	dBuV/m	dBuV/m	dB	dBuV	dB	dB/m	deg	cm		
1	2390.00	53.59	54.00	-0.41	23.20	2.22	28.17	0.00	227	100 Average	VERTICAL
2	2390.00	68.57	74.00	-5.43	38.18	2.22	28.17	0.00	227	100 Peak	VERTICAL
3	2406.94	96.00				2.22	28.21	0.00	227	100 Average	VERTICAL
4	2406.94	106.80				2.22	28.21	0.00	227	100 Peak	VERTICAL

Item 3, 4 are the fundamental frequency at 2422 MHz.

Channel 6

	Freq	Level	Limit Line	Over Limit	Read Level	CableAntenna Loss	Preamp Factor	T/Pos	A/Pos	Remark	Pol/Phase
	MHz	dBuV/m	dBuV/m	dB	dBuV	dB	dB/m	deg	cm		
1	2389.36	67.15	74.00	-6.85	36.77	2.21	28.17	0.00	96	130 Peak	VERTICAL
2	2390.00	52.79	54.00	-1.21	22.40	2.22	28.17	0.00	96	130 Average	VERTICAL
3	2420.33	100.61				2.23	28.25	0.00	96	130 Average	VERTICAL
4	2421.94	111.43				2.23	28.25	0.00	96	130 Peak	VERTICAL
5	2483.50	53.59	54.00	-0.41	22.96	2.26	28.37	0.00	96	130 Average	VERTICAL
6	2483.50	67.84	74.00	-6.16	37.21	2.26	28.37	0.00	96	130 Peak	VERTICAL

Item 3, 4 are the fundamental frequency at 2437MHz.

Channel 9

	Freq	Level	Limit Line	Over Limit	Read Level	CableAntenna Loss	Preamp Factor	T/Pos	A/Pos	Remark	Pol/Phase
	MHz	dBuV/m	dBuV/m	dB	dBuV	dB	dB/m	deg	cm		
1	2468.35	97.96				2.26	28.37	0.00	95	122 Average	VERTICAL
2	2468.67	107.80				2.26	28.37	0.00	95	122 Peak	VERTICAL
3	2483.50	53.81	54.00	-0.19	23.18	2.26	28.37	0.00	95	122 Average	VERTICAL
4	2483.50	70.63	74.00	-3.37	40.00	2.26	28.37	0.00	95	122 Peak	VERTICAL

Item 1, 2 are the fundamental frequency at 2452 MHz.

Note:

Emission level (dBuV/m) = 20 log Emission level (uV/m).

Corrected Reading: Antenna Factor + Cable Loss + Read Level - Preamp Factor = Level.

Temperature	23°C	Humidity	56%
Test Engineer	Serway Li	Configurations	IEEE 802.11b CH 1, 6, 11 / Ant. 2
Test Date	Jun. 13, 2011		

Channel 1

	Freq	Level	Limit	Over	Read	Cable	Preamp	Antenna	T/Pos	A/Pos	Remark	Pol/Phase
	MHz	dBuV/m	dBuV/m	dB	dBuV	dB	dB	dB/m	deg	cm		
1	2389.60	65.11	74.00	-8.89	35.20	2.04	0.00	27.87	123	132	Peak	VERTICAL
2	2390.00	47.84	54.00	-6.16	17.92	2.05	0.00	27.87	123	132	Average	VERTICAL
3 p	2411.00	112.99				2.05	0.00	27.84	123	132	Peak	VERTICAL
4 a	2411.20	108.91				2.05	0.00	27.84	123	132	Average	VERTICAL

Item 3, 4 are the fundamental frequency at 2412 MHz.

Channel 6

	Freq	Level	Limit	Over	Read	Cable	Preamp	Antenna	T/Pos	A/Pos	Remark	Pol/Phase
	MHz	dBuV/m	dBuV/m	dB	dBuV	dB	dB	dB/m	deg	cm		
1	2389.80	59.37	74.00	-14.63	29.45	2.05	0.00	27.87	239	133	Peak	VERTICAL
2	2390.00	46.86	54.00	-7.14	16.94	2.05	0.00	27.87	239	133	Average	VERTICAL
3 a	2436.20	107.79				2.07	0.00	27.81	239	133	Average	VERTICAL
4 p	2438.00	111.36				2.07	0.00	27.78	239	133	Peak	VERTICAL
5	2483.50	46.60	54.00	-7.40	16.77	2.10	0.00	27.73	239	133	Average	VERTICAL
6	2483.70	58.09	74.00	-15.91	28.26	2.10	0.00	27.73	239	133	Peak	VERTICAL

Item 3, 4 are the fundamental frequency at 2437MHz.

Channel 11

	Freq	Level	Limit	Over	Read	Cable	Preamp	Antenna	T/Pos	A/Pos	Remark	Pol/Phase
	MHz	dBuV/m	dBuV/m	dB	dBuV	dB	dB	dB/m	deg	cm		
1 p	2464.60	109.47				2.08	0.00	27.76	122	132	Peak	VERTICAL
2 a	2464.70	105.91				2.08	0.00	27.76	122	132	Average	VERTICAL
3	2484.90	63.54	74.00	-10.46	33.71	2.10	0.00	27.73	122	132	Peak	VERTICAL
4	2484.90	46.26	54.00	-7.74	16.43	2.10	0.00	27.73	122	132	Average	VERTICAL

Item 1, 2 are the fundamental frequency at 2462 MHz.

Temperature	23°C	Humidity	56%
Test Engineer	Serway Li	Configurations	IEEE 802.11g CH 1, 6, 11 / Ant. 2
Test Date	Jun. 13, 2011		

Channel 1

	Freq	Level	Limit Line	Over Limit	Read Level	Cable Loss	Antenna Factor	Preamp Factor	T/Pos	A/Pos	Remark	Pol/Phase
	MHz	dBuV/m	dBuV/m	dB	dBuV	dB	dB/m	dB	deg	cm		
1	2390.00	53.47	54.00	-0.53	23.08	2.22	28.17	0.00	284	100	Average	VERTICAL
2	2390.00	70.07	74.00	-3.93	39.68	2.22	28.17	0.00	284	100	Peak	VERTICAL
3	2406.39	102.39				2.22	28.21	0.00	284	100	Average	VERTICAL
4	2409.60	112.30				2.22	28.21	0.00	284	100	Peak	VERTICAL

Item 3, 4 are the fundamental frequency at 2412 MHz.

Channel 6

	Freq	Level	Limit Line	Over Limit	Read Level	Cable Loss	Antenna Factor	Preamp Factor	T/Pos	A/Pos	Remark	Pol/Phase
	MHz	dBuV/m	dBuV/m	dB	dBuV	dB	dB/m	dB	deg	cm		
1	2388.56	65.17	74.00	-8.83	34.79	2.21	28.17	0.00	92	127	Peak	VERTICAL
2	2390.00	49.83	54.00	-4.17	19.44	2.22	28.17	0.00	92	127	Average	VERTICAL
3	2429.95	106.86				2.23	28.25	0.00	92	127	Average	VERTICAL
4	2430.75	116.42				2.23	28.25	0.00	92	127	Peak	VERTICAL
5	2483.50	50.98	54.00	-3.02	20.35	2.26	28.37	0.00	92	127	Average	VERTICAL
6	2484.78	68.21	74.00	-5.79	37.58	2.26	28.37	0.00	92	127	Peak	VERTICAL

Item 3, 4 are the fundamental frequency at 2437 MHz.

Channel 11

	Freq	Level	Limit Line	Over Limit	Read Level	Cable Loss	Antenna Factor	Preamp Factor	T/Pos	A/Pos	Remark	Pol/Phase
	MHz	dBuV/m	dBuV/m	dB	dBuV	dB	dB/m	dB	deg	cm		
1	2468.41	104.09				2.26	28.37	0.00	94	126	Average	VERTICAL
2	2469.53	113.58				2.26	28.37	0.00	94	126	Peak	VERTICAL
3	2483.50	53.60	54.00	-0.40	22.97	2.26	28.37	0.00	94	126	Average	VERTICAL
4	2483.50	67.68	74.00	-6.32	37.05	2.26	28.37	0.00	94	126	Peak	VERTICAL

Item 1, 2 are the fundamental frequency at 2462 MHz.

Note:

Emission level (dBuV/m) = 20 log Emission level (uV/m).

Corrected Reading: Antenna Factor + Cable Loss + Read Level - Preamp Factor = Level.

<For Ant. 3>

Temperature	23°C	Humidity	56%
Test Engineer	Serway Li	Configurations	IEEE 802.11n MCS0 20MHz Ch 1, 6, 11 / Ant. 3
Test Date	Jun. 16, 2011		

Channel 1

	Freq	Level	Limit Line	Over Limit	Read Level	Cable Loss	Preamp Factor	Antenna Factor	T/Pos	A/Pos	Remark	Pol/Phase
	MHz	dBuV/m	dBuV/m	dB	dBuV	dB	dB	dB/m	deg	cm		
1	2389.60	70.06	74.00	-3.94	39.03	3.16	0.00	27.87	359	102	Peak	VERTICAL
2	2390.00	53.76	54.00	-0.24	22.69	3.20	0.00	27.87	359	102	Average	VERTICAL
3 a	2407.00	103.51				3.20	0.00	27.84	359	102	Average	VERTICAL
4 p	2412.00	115.04				3.20	0.00	27.84	359	102	Peak	VERTICAL

Item 3, 4 are the fundamental frequency at 2412 MHz.

Channel 6

	Freq	Level	Limit Line	Over Limit	Read Level	Cable Loss	Preamp Factor	Antenna Factor	T/Pos	A/Pos	Remark	Pol/Phase
	MHz	dBuV/m	dBuV/m	dB	dBuV	dB	dB	dB/m	deg	cm		
1	2390.00	64.43	74.00	-9.57	33.36	3.20	0.00	27.87	359	100	Peak	VERTICAL
2	2390.00	51.89	54.00	-2.11	20.82	3.20	0.00	27.87	359	100	Average	VERTICAL
3 a	2429.60	108.65				3.23	0.00	27.81	359	100	Average	VERTICAL
4 p	2440.40	118.74				3.23	0.00	27.78	359	100	Peak	VERTICAL
5	2483.50	65.78	74.00	-8.22	34.74	3.31	0.00	27.73	359	100	Peak	VERTICAL
6	2483.70	53.15	54.00	-0.85	22.11	3.31	0.00	27.73	359	100	Average	VERTICAL

Item 3, 4 are the fundamental frequency at 2437MHz.

Channel 11

	Freq	Level	Limit Line	Over Limit	Read Level	Cable Loss	Preamp Factor	Antenna Factor	T/Pos	A/Pos	Remark	Pol/Phase
	MHz	dBuV/m	dBuV/m	dB	dBuV	dB	dB	dB/m	deg	cm		
1 a	2469.20	104.38				3.31	0.00	27.76	6	100	Average	VERTICAL
2 p	2470.00	112.60				3.31	0.00	27.76	6	100	Peak	VERTICAL
3	2483.50	65.24	74.00	-8.76	34.20	3.31	0.00	27.73	6	100	Peak	VERTICAL
4	2483.50	53.64	54.00	-0.36	22.60	3.31	0.00	27.73	6	100	Average	VERTICAL

Item 1, 2 are the fundamental frequency at 2462 MHz.

Temperature	23°C	Humidity	56%
Test Engineer	Serway Li	Configurations	IEEE 802.11n MCS0 40MHz Ch 3, 6, 9 / Ant. 3
Test Date	Jun. 16, 2011		

Channel 3

	Freq	Level	Limit Line	Over Limit	Read Level	Cable Loss	Preamp Factor	Antenna Factor	T/Pos	A/Pos	Remark	Pol/Phase
	MHz	dBuV/m	dBuV/m	dB	dBuV	dB	dB	dB/m	deg	cm		
1	2390.00	70.44	74.00	-3.56	39.37	3.20	0.00	27.87	359	105	Peak	VERTICAL
2	2390.00	53.48	54.00	-0.52	22.41	3.20	0.00	27.87	359	105	Average	VERTICAL
3 a	2412.80	98.24				3.20	0.00	27.84	359	105	Average	VERTICAL
4 p	2415.60	109.38				3.23	0.00	27.84	359	105	Peak	VERTICAL

Item 3, 4 are the fundamental frequency at 2422 MHz.

Channel 6

	Freq	Level	Limit Line	Over Limit	Read Level	Cable Loss	Preamp Factor	Antenna Factor	T/Pos	A/Pos	Remark	Pol/Phase
	MHz	dBuV/m	dBuV/m	dB	dBuV	dB	dB	dB/m	deg	cm		
1	2388.80	66.58	74.00	-7.42	35.55	3.16	0.00	27.87	2	100	Peak	VERTICAL
2	2390.00	52.58	54.00	-1.42	21.51	3.20	0.00	27.87	2	100	Average	VERTICAL
3 a	2423.00	102.38				3.23	0.00	27.81	2	100	Average	VERTICAL
4 p	2429.00	111.71				3.23	0.00	27.81	2	100	Peak	VERTICAL
5	2483.50	65.01	74.00	-8.99	33.97	3.31	0.00	27.73	2	100	Peak	VERTICAL
6	2483.50	53.28	54.00	-0.72	22.24	3.31	0.00	27.73	2	100	Average	VERTICAL

Item 3, 4 are the fundamental frequency at 2437MHz.

Channel 9

	Freq	Level	Limit Line	Over Limit	Read Level	Cable Loss	Preamp Factor	Antenna Factor	T/Pos	A/Pos	Remark	Pol/Phase
	MHz	dBuV/m	dBuV/m	dB	dBuV	dB	dB	dB/m	deg	cm		
1 p	2463.20	108.24				3.27	0.00	27.76	357	100	Peak	VERTICAL
2 a	2469.20	97.97				3.31	0.00	27.76	357	100	Average	VERTICAL
3	2483.50	72.82	74.00	-1.18	41.78	3.31	0.00	27.73	357	100	Peak	VERTICAL
4	2483.50	53.91	54.00	-0.09	22.87	3.31	0.00	27.73	357	100	Average	VERTICAL

Item 1, 2 are the fundamental frequency at 2452 MHz.

Note:

Emission level (dBuV/m) = 20 log Emission level (uV/m).

Corrected Reading: Antenna Factor + Cable Loss + Read Level - Preamp Factor = Level.

Temperature	23°C	Humidity	56%
Test Engineer	Serway Li	Configurations	IEEE 802.11b CH 1, 6, 11 / Ant. 3
Test Date	Jun. 16, 2011		

Channel 1

	Freq	Level	Limit	Over	Read	Cable	Preamp	Antenna	T/Pos	A/Pos	Remark	Pol/Phase
	MHz	dBuV/m	dBuV/m	dB	dBuV	dB	dB	dB/m	deg	cm		
1 l	2388.40	69.55	74.00	-4.45	38.52	3.16	0.00	27.87	3	100	Peak	VERTICAL
2 l	2390.00	53.61	54.00	-0.39	22.54	3.20	0.00	27.87	3	100	Average	VERTICAL
3 p	2413.00	116.69				3.20	0.00	27.84	3	100	Peak	VERTICAL
4 a	2414.00	113.52				3.20	0.00	27.84	3	100	Average	VERTICAL

Item 3, 4 are the fundamental frequency at 2412 MHz.

Channel 6

	Freq	Level	Limit	Over	Read	Cable	Preamp	Antenna	T/Pos	A/Pos	Remark	Pol/Phase
	MHz	dBuV/m	dBuV/m	dB	dBuV	dB	dB	dB/m	deg	cm		
1	2390.00	63.62	74.00	-10.38	32.55	3.20	0.00	27.87	360	100	Peak	VERTICAL
2 l	2390.00	53.07	54.00	-0.93	22.00	3.20	0.00	27.87	360	100	Average	VERTICAL
3 a	2435.20	114.67				3.23	0.00	27.81	360	100	Average	VERTICAL
4 p	2436.20	118.19				3.23	0.00	27.81	360	100	Peak	VERTICAL
5	2483.50	66.13	74.00	-7.87	35.09	3.31	0.00	27.73	360	100	Peak	VERTICAL
6 l	2483.50	53.95	54.00	-0.05	22.91	3.31	0.00	27.73	360	100	Average	VERTICAL

Item 3, 4 are the fundamental frequency at 2437MHz.

Channel 11

	Freq	Level	Limit	Over	Read	Cable	Preamp	Antenna	T/Pos	A/Pos	Remark	Pol/Phase
	MHz	dBuV/m	dBuV/m	dB	dBuV	dB	dB	dB/m	deg	cm		
1 a	2463.80	112.82				3.27	0.00	27.76	359	100	Average	VERTICAL
2 p	2464.60	115.98				3.27	0.00	27.76	359	100	Peak	VERTICAL
3 l	2483.50	53.09	54.00	-0.91	22.05	3.31	0.00	27.73	359	100	Average	VERTICAL
4 l	2485.70	68.35	74.00	-5.65	37.31	3.31	0.00	27.73	359	100	Peak	VERTICAL

Item 1, 2 are the fundamental frequency at 2462 MHz.

Temperature	23°C	Humidity	56%
Test Engineer	Serway Li	Configurations	IEEE 802.11g CH 1, 6, 11 / Ant. 3
Test Date	Jun. 16, 2011		

Channel 1

	Freq	Level	Limit Line	Over Limit	Read Level	Cable Loss	Preamp Factor	Antenna Factor	T/Pos	A/Pos	Remark	Pol/Phase
	MHz	dBuV/m	dBuV/m	dB	dBuV	dB	dB	dB/m	deg	cm		
1 !	2390.00	70.10	74.00	-3.90	39.03	3.20	0.00	27.87	1	100	Peak	VERTICAL
2 !	2390.00	53.81	54.00	-0.19	22.74	3.20	0.00	27.87	1	100	Average	VERTICAL
3 a	2411.00	104.79				3.20	0.00	27.84	1	100	Average	VERTICAL
4 p	2414.80	115.62				3.20	0.00	27.84	1	100	Peak	VERTICAL

Item 3, 4 are the fundamental frequency at 2412 MHz.

Channel 6

	Freq	Level	Limit Line	Over Limit	Read Level	Cable Loss	Preamp Factor	Antenna Factor	T/Pos	A/Pos	Remark	Pol/Phase
	MHz	dBuV/m	dBuV/m	dB	dBuV	dB	dB	dB/m	deg	cm		
1	2390.00	63.81	74.00	-10.19	32.74	3.20	0.00	27.87	359	100	Peak	VERTICAL
2 !	2390.00	51.82	54.00	-2.18	20.75	3.20	0.00	27.87	359	100	Average	VERTICAL
3 p	2429.60	119.30				3.23	0.00	27.81	359	100	Peak	VERTICAL
4 a	2430.20	109.01				3.23	0.00	27.81	359	100	Average	VERTICAL
5	2483.50	64.37	74.00	-9.63	33.33	3.31	0.00	27.73	359	100	Peak	VERTICAL
6 !	2483.50	53.12	54.00	-0.88	22.08	3.31	0.00	27.73	359	100	Average	VERTICAL

Item 3, 4 are the fundamental frequency at 2437 MHz.

Channel 11

	Freq	Level	Limit Line	Over Limit	Read Level	Cable Loss	Preamp Factor	Antenna Factor	T/Pos	A/Pos	Remark	Pol/Phase
	MHz	dBuV/m	dBuV/m	dB	dBuV	dB	dB	dB/m	deg	cm		
1 p	2468.40	114.77				3.31	0.00	27.76	357	100	Peak	VERTICAL
2 a	2469.60	105.95				3.31	0.00	27.76	357	100	Average	VERTICAL
3	2483.50	66.96	74.00	-7.04	35.92	3.31	0.00	27.73	357	100	Peak	VERTICAL
4 !	2483.50	53.52	54.00	-0.48	22.48	3.31	0.00	27.73	357	100	Average	VERTICAL

Item 1, 2 are the fundamental frequency at 2462 MHz.

Note:

Emission level (dBuV/m) = 20 log Emission level (uV/m).

Corrected Reading: Antenna Factor + Cable Loss + Read Level - Preamp Factor = Level.

<For Ant. 4>

Temperature	23°C	Humidity	56%
Test Engineer	Serway Li	Configurations	IEEE 802.11n MCS0 20MHz Ch 1, 6, 11 / Ant. 4
Test Date	Jun. 15, 2011		

Channel 1

	Freq	Level	Limit	Over	Read	CableAntenna	Preamp	Remark	Pol/Phase	
	MHz	dBuV/m	dBuV/m	dB	dBuV	Loss	Factor			
						dB	dB/m	dB		
1	2388.40	69.01	74.00	-4.99	38.10	2.86	28.05	0.00	Peak	VERTICAL
2	2390.00	53.53	54.00	-0.47	22.60	2.88	28.05	0.00	Average	VERTICAL
3	2410.40	111.79				2.88	28.09	0.00	Peak	VERTICAL
4	2411.00	101.99				2.88	28.09	0.00	Average	VERTICAL

Item 3, 4 are the fundamental frequency at 2412 MHz.

Channel 6

	Freq	Level	Limit	Over	Read	CableAntenna	Preamp	Remark	Pol/Phase	
	MHz	dBuV/m	dBuV/m	dB	dBuV	Loss	Factor			
						dB	dB/m	dB		
1	2387.40	69.43	74.00	-4.57	38.52	2.86	28.05	0.00	Peak	VERTICAL
2	2390.00	51.22	54.00	-2.78	20.29	2.88	28.05	0.00	Average	VERTICAL
3	2429.60	106.07				2.89	28.13	0.00	Average	VERTICAL
4	2429.80	116.62				2.89	28.13	0.00	Peak	VERTICAL
5	2483.50	52.60	54.00	-1.40	21.41	2.93	28.26	0.00	Average	VERTICAL
6	2484.90	71.50	74.00	-2.50	40.31	2.93	28.26	0.00	Peak	VERTICAL

Item 3, 4 are the fundamental frequency at 2437MHz.

Channel 11

	Freq	Level	Limit	Over	Read	CableAntenna	Preamp	Remark	Pol/Phase	
	MHz	dBuV/m	dBuV/m	dB	dBuV	Loss	Factor			
						dB	dB/m	dB		
1	2468.00	112.12				2.93	28.22	0.00	Peak	VERTICAL
2	2469.00	102.25				2.93	28.26	0.00	Average	VERTICAL
3	2483.50	53.72	54.00	-0.28	22.53	2.93	28.26	0.00	Average	VERTICAL
4	2484.10	70.13	74.00	-3.87	38.94	2.93	28.26	0.00	Peak	VERTICAL

Item 1, 2 are the fundamental frequency at 2462 MHz.

Temperature	23°C	Humidity	56%
Test Engineer	Serway Li	Configurations	IEEE 802.11n MCS0 40MHz Ch 3, 6, 9 / Ant. 4
Test Date	Jun. 15, 2011		

Channel 3

	Freq	Level	Limit	Over	Read	CableAntenna	Preamp	Remark	Pol/Phase	
	MHz	dBuV/m	dBuV/m	dB	dBuV	dB	dB/m	dB		
1	2390.00	53.43	54.00	-0.57	22.50	2.88	28.05	0.00	Average	VERTICAL
2	2390.00	69.71	74.00	-4.29	38.78	2.88	28.05	0.00	Peak	VERTICAL
3	2412.80	97.18				2.88	28.09	0.00	Average	VERTICAL
4	2414.00	107.48				2.88	28.09	0.00	Peak	VERTICAL

Item 3, 4 are the fundamental frequency at 2422 MHz.

Channel 6

	Freq	Level	Limit	Over	Read	CableAntenna	Preamp	Remark	Pol/Phase	
	MHz	dBuV/m	dBuV/m	dB	dBuV	dB	dB/m	dB		
1	2386.00	68.34	74.00	-5.66	37.43	2.86	28.05	0.00	Peak	VERTICAL
2	2390.00	53.32	54.00	-0.68	22.39	2.88	28.05	0.00	Average	VERTICAL
3	2430.20	98.66				2.89	28.13	0.00	Average	VERTICAL
4	2431.00	109.85				2.89	28.13	0.00	Peak	VERTICAL
5	2483.50	52.69	54.00	-1.31	21.50	2.93	28.26	0.00	Average	VERTICAL
6	2483.90	65.92	74.00	-8.08	34.73	2.93	28.26	0.00	Peak	VERTICAL

Item 3, 4 are the fundamental frequency at 2437MHz.

Channel 9

	Freq	Level	Limit	Over	Read	CableAntenna	Preamp	Remark	Pol/Phase	
	MHz	dBuV/m	dBuV/m	dB	dBuV	dB	dB/m	dB		
1	2468.00	96.95				2.93	28.22	0.00	Average	VERTICAL
2	2468.40	107.09				2.93	28.26	0.00	Peak	VERTICAL
3	2483.50	53.58	54.00	-0.42	22.39	2.93	28.26	0.00	Average	VERTICAL
4	2483.50	72.77	74.00	-1.23	41.58	2.93	28.26	0.00	Peak	VERTICAL

Item 1, 2 are the fundamental frequency at 2452 MHz.

Note:

Emission level (dBuV/m) = 20 log Emission level (uV/m).

Corrected Reading: Antenna Factor + Cable Loss + Read Level - Preamp Factor = Level.

Temperature	23°C	Humidity	56%
Test Engineer	Serway Li	Configurations	IEEE 802.11b CH 1, 6, 11 / Ant. 4
Test Date	Jun. 15, 2011		

Channel 1

	Freq	Level	Limit Line	Over Limit	Read Level	CableAntenna Loss	Antenna Factor	Preamp Factor	Remark	Pol/Phase
	MHz	dBuV/m	dBuV/m	dB	dBuV	dB	dB/m	dB		
1	2386.20	53.68	54.00	-0.32	22.77	2.86	28.05	0.00	Average	VERTICAL
2	2386.20	61.90	74.00	-12.10	30.99	2.86	28.05	0.00	Peak	VERTICAL
3	2411.20	112.21				2.88	28.09	0.00	Peak	VERTICAL
4	2413.80	108.80				2.88	28.09	0.00	Average	VERTICAL

Item 3, 4 are the fundamental frequency at 2412 MHz.

Channel 6

	Freq	Level	Limit Line	Over Limit	Read Level	CableAntenna Loss	Antenna Factor	Preamp Factor	Remark	Pol/Phase
	MHz	dBuV/m	dBuV/m	dB	dBuV	dB	dB/m	dB		
1	2389.80	60.55	74.00	-13.45	29.62	2.88	28.05	0.00	Peak	VERTICAL
2	2390.00	49.45	54.00	-4.55	18.52	2.88	28.05	0.00	Average	VERTICAL
3	2436.00	112.07				2.89	28.18	0.00	Average	VERTICAL
4	2436.00	115.40				2.89	28.18	0.00	Peak	VERTICAL
5	2483.50	52.48	54.00	-1.52	21.29	2.93	28.26	0.00	Average	VERTICAL
6	2483.50	62.36	74.00	-11.64	31.17	2.93	28.26	0.00	Peak	VERTICAL

Item 3, 4 are the fundamental frequency at 2437MHz.

Channel 11

	Freq	Level	Limit Line	Over Limit	Read Level	CableAntenna Loss	Antenna Factor	Preamp Factor	Remark	Pol/Phase
	MHz	dBuV/m	dBuV/m	dB	dBuV	dB	dB/m	dB		
1	2463.80	110.60				2.91	28.22	0.00	Average	VERTICAL
2	2464.60	114.17				2.91	28.22	0.00	Peak	VERTICAL
3	2483.90	67.30	74.00	-6.70	36.11	2.93	28.26	0.00	Peak	VERTICAL
4	2487.80	53.81	54.00	-0.19	22.58	2.93	28.30	0.00	Average	VERTICAL

Item 1, 2 are the fundamental frequency at 2462 MHz.

Temperature	23°C	Humidity	56%
Test Engineer	Serway Li	Configurations	IEEE 802.11g CH 1, 6, 11 / Ant. 4
Test Date	Jun. 15, 2011		

Channel 1

	Freq	Level	Limit Line	Over Limit	Read Level	Cable Loss	Antenna Factor	Preamp Factor	Remark	Pol/Phase
	MHz	dBuV/m	dBuV/m	dB	dBuV	dB	dB/m	dB		
1	2387.60	71.14	74.00	-2.86	40.23	2.86	28.05	0.00	Peak	VERTICAL
2	2390.00	53.47	54.00	-0.53	22.54	2.88	28.05	0.00	Average	VERTICAL
3	2410.80	112.63				2.88	28.09	0.00	Peak	VERTICAL
4	2411.00	103.08				2.88	28.09	0.00	Average	VERTICAL

Item 3, 4 are the fundamental frequency at 2412 MHz.

Channel 6

	Freq	Level	Limit Line	Over Limit	Read Level	Cable Loss	Antenna Factor	Preamp Factor	Remark	Pol/Phase
	MHz	dBuV/m	dBuV/m	dB	dBuV	dB	dB/m	dB		
1	2389.80	63.47	74.00	-10.53	32.54	2.88	28.05	0.00	Peak	VERTICAL
2	2390.00	49.84	54.00	-4.16	18.91	2.88	28.05	0.00	Average	VERTICAL
3	2439.20	106.70				2.89	28.18	0.00	Average	VERTICAL
4	2441.00	117.90				2.91	28.18	0.00	Peak	VERTICAL
5	2483.50	53.88	54.00	-0.12	22.69	2.93	28.26	0.00	Average	VERTICAL
6	2483.70	69.53	74.00	-4.47	38.34	2.93	28.26	0.00	Peak	VERTICAL

Item 3, 4 are the fundamental frequency at 2437 MHz.

Channel 11

	Freq	Level	Limit Line	Over Limit	Read Level	Cable Loss	Antenna Factor	Preamp Factor	Remark	Pol/Phase
	MHz	dBuV/m	dBuV/m	dB	dBuV	dB	dB/m	dB		
1	2468.00	112.95				2.93	28.22	0.00	Peak	VERTICAL
2	2468.80	103.43				2.93	28.26	0.00	Average	VERTICAL
3	2483.50	53.87	54.00	-0.13	22.68	2.93	28.26	0.00	Average	VERTICAL
4	2484.30	72.01	74.00	-1.99	40.82	2.93	28.26	0.00	Peak	VERTICAL

Item 1, 2 are the fundamental frequency at 2462 MHz.

Note:

Emission level (dBuV/m) = 20 log Emission level (uV/m).

Corrected Reading: Antenna Factor + Cable Loss + Read Level - Preamp Factor = Level.

<For Ant. 5>

Temperature	20°C	Humidity	63%
Test Engineer	Serway Li	Configurations	IEEE 802.11n MCS0 20MHz Ch 1, 6, 11 / Ant. 5
Test Date	Jul. 30, 2011		

Channel 1

	Freq	Level	Limit Line	Over Limit	Read Level	Cable Loss	Preamp Factor	Antenna Factor	T/Pos	A/Pos	Remark	Pol/Phase
	MHz	dBuV/m	dBuV/m	dB	dBuV	dB	dB	dB/m	deg	cm		
1	2390.00	57.90	74.00	-16.10	26.83	3.20	0.00	27.87	89	106	Peak	VERTICAL
2	2390.00	45.82	54.00	-8.18	14.75	3.20	0.00	27.87	89	106	Average	VERTICAL
3 a	2410.60	95.24				3.20	0.00	27.84	89	106	Average	VERTICAL
4 p	2411.80	104.29				3.20	0.00	27.84	89	106	Peak	VERTICAL

Item 3, 4 are the fundamental frequency at 2412 MHz.

Channel 6

	Freq	Level	Limit Line	Over Limit	Read Level	Cable Loss	Preamp Factor	Antenna Factor	T/Pos	A/Pos	Remark	Pol/Phase
	MHz	dBuV/m	dBuV/m	dB	dBuV	dB	dB	dB/m	deg	cm		
1	2389.40	55.88	74.00	-18.12	24.85	3.16	0.00	27.87	272	102	Peak	VERTICAL
2	2390.00	44.63	54.00	-9.37	13.56	3.20	0.00	27.87	272	102	Average	VERTICAL
3 a	2442.80	92.26				3.27	0.00	27.78	272	102	Average	VERTICAL
4 p	2443.00	103.36				3.27	0.00	27.78	272	102	Peak	VERTICAL
5	2483.50	55.10	74.00	-18.90	24.06	3.31	0.00	27.73	272	102	Peak	VERTICAL
6	2483.50	44.51	54.00	-9.49	13.47	3.31	0.00	27.73	272	102	Average	VERTICAL

Item 3, 4 are the fundamental frequency at 2437MHz.

Channel 11

	Freq	Level	Limit Line	Over Limit	Read Level	Cable Loss	Preamp Factor	Antenna Factor	T/Pos	A/Pos	Remark	Pol/Phase
	MHz	dBuV/m	dBuV/m	dB	dBuV	dB	dB	dB/m	deg	cm		
1 a	2469.20	94.61				3.31	0.00	27.76	271	271	Average	VERTICAL
2 p	2470.00	104.10				3.31	0.00	27.76	271	100	Peak	VERTICAL
3	2483.50	45.50	54.00	-8.50	14.46	3.31	0.00	27.73	271	100	Average	VERTICAL
4	2483.90	57.16	74.00	-16.84	26.12	3.31	0.00	27.73	271	100	Peak	VERTICAL

Item 1, 2 are the fundamental frequency at 2462 MHz.

Temperature	20°C	Humidity	63%
Test Engineer	Serway Li	Configurations	IEEE 802.11n MCS0 40MHz Ch 3, 6, 9 / Ant. 5
Test Date	Jul. 30, 2011		

Channel 3

	Freq	Level	Limit Line	Over Limit	Read Level	Cable Loss	Preamp Factor	Antenna Factor	T/Pos	A/Pos	Remark	Pol/Phase
	MHz	dBuV/m	dBuV/m	dB	dBuV	dB	dB	dB/m	deg	cm		
1	2390.00	66.88	74.00	-7.12	35.81	3.20	0.00	27.87	89	107	Peak	VERTICAL
2	2390.00	51.55	54.00	-2.45	20.48	3.20	0.00	27.87	89	107	Average	VERTICAL
3	2407.20	104.85				3.20	0.00	27.84	89	107	Peak	VERTICAL
4	2410.80	95.15				3.20	0.00	27.84	89	107	Average	VERTICAL

Item 3, 4 are the fundamental frequency at 2422 MHz.

Channel 6

	Freq	Level	Limit Line	Over Limit	Read Level	Cable Loss	Preamp Factor	Antenna Factor	T/Pos	A/Pos	Remark	Pol/Phase
	MHz	dBuV/m	dBuV/m	dB	dBuV	dB	dB	dB/m	deg	cm		
1	2389.60	70.64	74.00	-3.36	39.61	3.16	0.00	27.87	273	102	Peak	VERTICAL
2	2390.00	52.62	54.00	-1.38	21.55	3.20	0.00	27.87	273	102	Average	VERTICAL
3	2423.00	97.01				3.23	0.00	27.81	273	102	Average	VERTICAL
4	2424.20	109.76				3.23	0.00	27.81	273	102	Peak	VERTICAL
5	2483.50	50.92	54.00	-3.08	19.88	3.31	0.00	27.73	273	102	Average	VERTICAL
6	2483.90	67.73	74.00	-6.27	36.69	3.31	0.00	27.73	273	102	Peak	VERTICAL

Item 3, 4 are the fundamental frequency at 2437MHz.

Channel 9

	Freq	Level	Limit Line	Over Limit	Read Level	Cable Loss	Preamp Factor	Antenna Factor	T/Pos	A/Pos	Remark	Pol/Phase
	MHz	dBuV/m	dBuV/m	dB	dBuV	dB	dB	dB/m	deg	cm		
1	2466.80	107.72				3.31	0.00	27.76	270	100	Peak	VERTICAL
2	2468.40	96.03				3.31	0.00	27.76	270	100	Average	VERTICAL
3	2483.50	53.34	54.00	-0.66	22.30	3.31	0.00	27.73	270	100	Average	VERTICAL
4	2490.70	72.15	74.00	-1.85	41.14	3.31	0.00	27.70	270	100	Peak	VERTICAL

Item 1, 2 are the fundamental frequency at 2452 MHz.

Note:

Emission level (dBuV/m) = 20 log Emission level (uV/m).

Corrected Reading: Antenna Factor + Cable Loss + Read Level - Preamp Factor = Level.

Temperature	20°C	Humidity	63%
Test Engineer	Serway Li	Configurations	IEEE 802.11b CH 1, 6, 11 / Ant. 5
Test Date	Jul. 30, 2011		

Channel 1

	Freq	Level	Limit	Over	Read	Cable	Preamp	Antenna	T/Pos	A/Pos	Remark	Pol/Phase
	MHz	dBuV/m	dBuV/m	dB	dBuV	dB	dB	dB/m	deg	cm		
1	2389.20	56.86	74.00	-17.14	25.83	3.16	0.00	27.87	89	106	Peak	VERTICAL
2	2390.00	45.17	54.00	-8.83	14.10	3.20	0.00	27.87	89	106	Average	VERTICAL
3 p	2411.00	106.95				3.20	0.00	27.84	89	106	Peak	VERTICAL
4 a	2411.20	103.36				3.20	0.00	27.84	89	106	Average	VERTICAL

Item 3, 4 are the fundamental frequency at 2412 MHz.

Channel 6

	Freq	Level	Limit	Over	Read	Cable	Preamp	Antenna	T/Pos	A/Pos	Remark	Pol/Phase
	MHz	dBuV/m	dBuV/m	dB	dBuV	dB	dB	dB/m	deg	cm		
1	2388.40	55.95	74.00	-18.05	24.92	3.16	0.00	27.87	272	102	Peak	VERTICAL
2	2390.00	44.61	54.00	-9.39	13.54	3.20	0.00	27.87	272	102	Average	VERTICAL
3 p	2438.00	105.17				3.23	0.00	27.78	272	102	Peak	VERTICAL
4 a	2438.80	101.54				3.23	0.00	27.78	272	102	Average	VERTICAL
5	2483.50	55.85	74.00	-18.15	24.81	3.31	0.00	27.73	272	102	Peak	VERTICAL
6	2483.50	44.51	54.00	-9.49	13.47	3.31	0.00	27.73	272	102	Average	VERTICAL

Item 3, 4 are the fundamental frequency at 2437MHz.

Channel 11

	Freq	Level	Limit	Over	Read	Cable	Preamp	Antenna	T/Pos	A/Pos	Remark	Pol/Phase
	MHz	dBuV/m	dBuV/m	dB	dBuV	dB	dB	dB/m	deg	cm		
1 a	2463.80	100.23				3.27	0.00	27.76	272	100	Average	VERTICAL
2 p	2464.60	103.76				3.27	0.00	27.76	272	100	Peak	VERTICAL
3	2483.50	44.89	54.00	-9.11	13.85	3.31	0.00	27.73	272	100	Average	VERTICAL
4	2485.50	55.65	74.00	-18.35	24.61	3.31	0.00	27.73	272	100	Peak	VERTICAL

Item 1, 2 are the fundamental frequency at 2462 MHz.

Temperature	20°C	Humidity	63%
Test Engineer	Serway Li	Configurations	IEEE 802.11g CH 1, 6, 11 / Ant. 5
Test Date	Jul. 30, 2011		

Channel 1

	Freq	Level	Limit	Over	Read	Cable	Preamp	Antenna	T/Pos	A/Pos	Remark	Pol/Phase
	MHz	dBuV/m	dBuV/m	dB	dBuV	dB	dB	dB/m	deg	cm		
1	2389.80	59.49	74.00	-14.51	28.42	3.20	0.00	27.87	91	107	Peak	VERTICAL
2	2390.00	46.57	54.00	-7.43	15.50	3.20	0.00	27.87	91	107	Average	VERTICAL
3 a	2410.40	97.61				3.20	0.00	27.84	91	91	Average	VERTICAL
4 p	2411.00	106.68				3.20	0.00	27.84	91	107	Peak	VERTICAL

Item 3, 4 are the fundamental frequency at 2412 MHz.

Channel 6

	Freq	Level	Limit	Over	Read	Cable	Preamp	Antenna	T/Pos	A/Pos	Remark	Pol/Phase
	MHz	dBuV/m	dBuV/m	dB	dBuV	dB	dB	dB/m	deg	cm		
1	2389.40	55.12	74.00	-18.88	24.09	3.16	0.00	27.87	271	100	Peak	VERTICAL
2	2390.00	44.52	54.00	-9.48	13.45	3.20	0.00	27.87	271	100	Average	VERTICAL
3 p	2440.60	105.27				3.23	0.00	27.78	271	100	Peak	VERTICAL
4 a	2443.40	94.27				3.27	0.00	27.78	271	100	Average	VERTICAL
5	2483.50	44.50	54.00	-9.50	13.46	3.31	0.00	27.73	271	100	Average	VERTICAL
6	2484.30	55.43	74.00	-18.57	24.39	3.31	0.00	27.73	271	100	Peak	VERTICAL

Item 3, 4 are the fundamental frequency at 2437 MHz.

Channel 11

	Freq	Level	Limit	Over	Read	Cable	Preamp	Antenna	T/Pos	A/Pos	Remark	Pol/Phase
	MHz	dBuV/m	dBuV/m	dB	dBuV	dB	dB	dB/m	deg	cm		
1 p	2466.20	108.49				3.27	0.00	27.76	280	135	Peak	VERTICAL
2 a	2468.60	97.53				3.31	0.00	27.76	280	135	Average	VERTICAL
3	2483.50	61.44	74.00	-12.56	30.40	3.31	0.00	27.73	280	135	Peak	VERTICAL
4	2483.50	47.46	54.00	-6.54	16.42	3.31	0.00	27.73	280	135	Average	VERTICAL

Item 1, 2 are the fundamental frequency at 2462 MHz.

Note:

Emission level (dBuV/m) = 20 log Emission level (uV/m).

Corrected Reading: Antenna Factor + Cable Loss + Read Level - Preamp Factor = Level.

For Emission not in Restricted Band

<For Ant. 1>

Low Band Edge Plot on Configuration IEEE 802.11n MCS0 20MHz / Ant. 1 / 2412 MHz

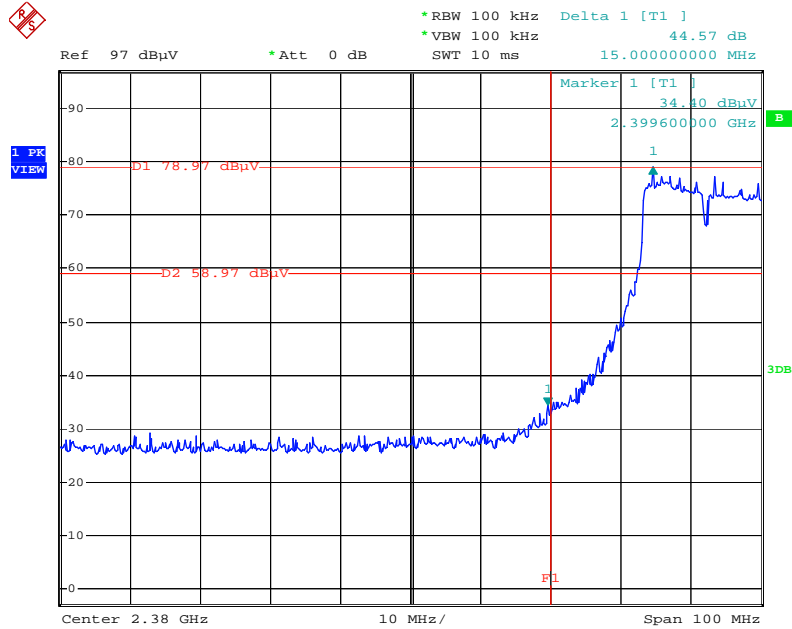

Date: 16.JUN.2011 02:38:37

High Band Edge Plot on Configuration IEEE 802.11n MCS0 20MHz / Ant. 1 / 2462 MHz

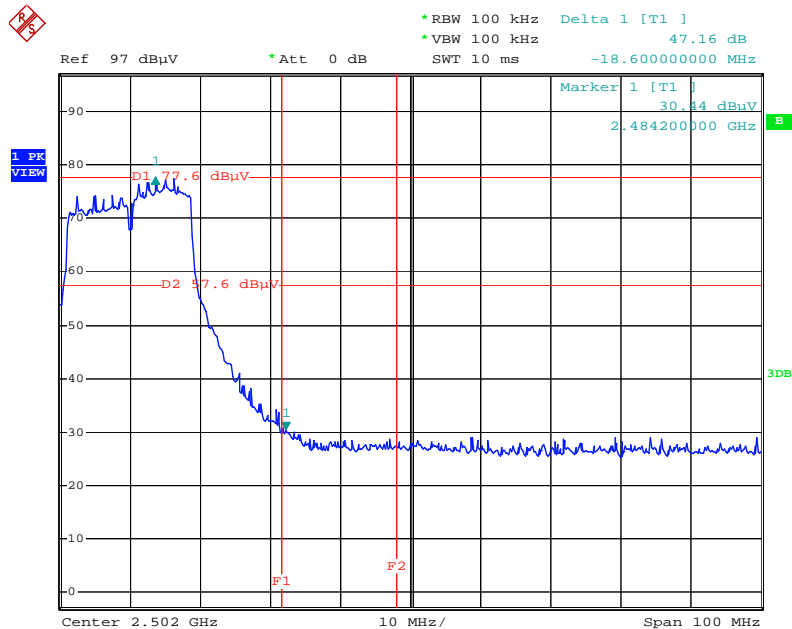

Date: 16.JUN.2011 02:24:43

Low Band Edge Plot on Configuration IEEE 802.11n MCS0 40MHz / Ant. 1 / 2422 MHz

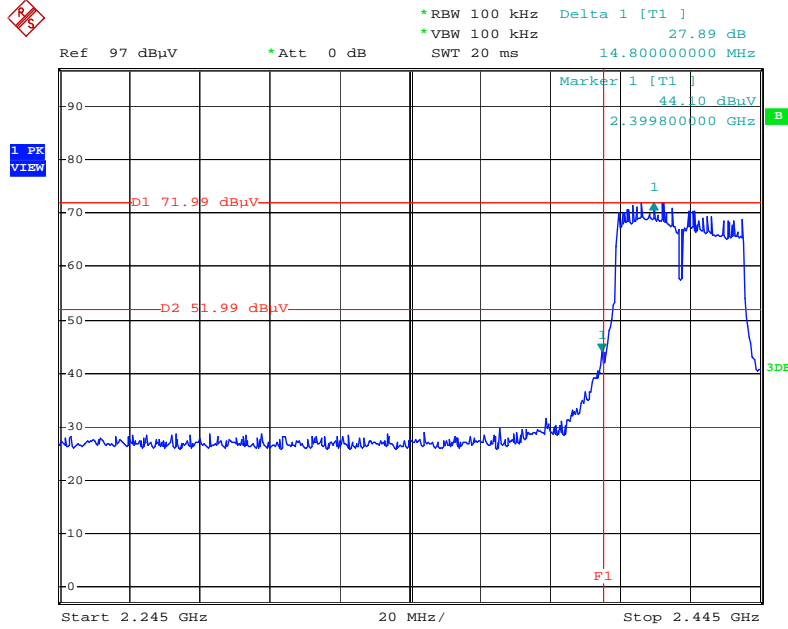

Date: 16.JUN.2011 02:31:07

High Band Edge Plot on Configuration IEEE 802.11n MCS0 40MHz / Ant. 1 / 2452 MHz

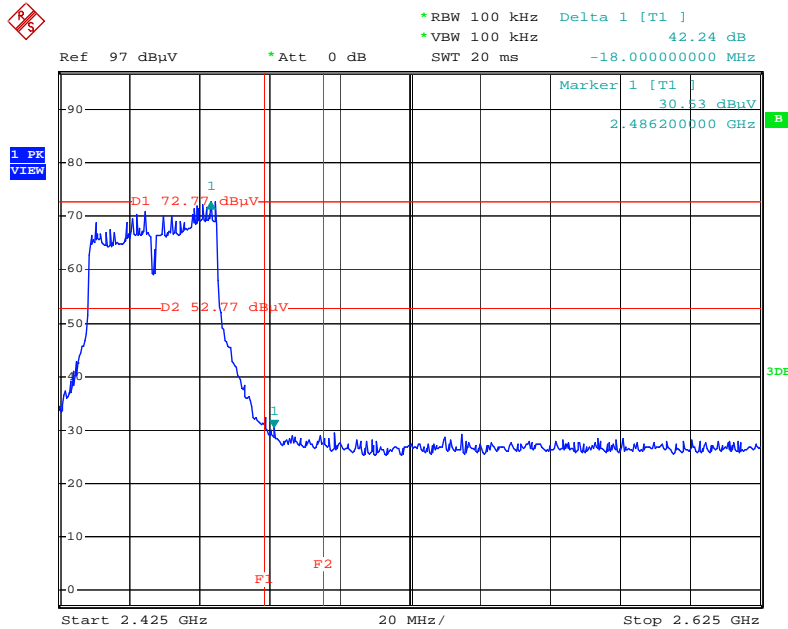

Date: 16.JUN.2011 02:27:12

Low Band Edge Plot on Configuration IEEE 802.11b / Ant. 1 / 2412 MHz

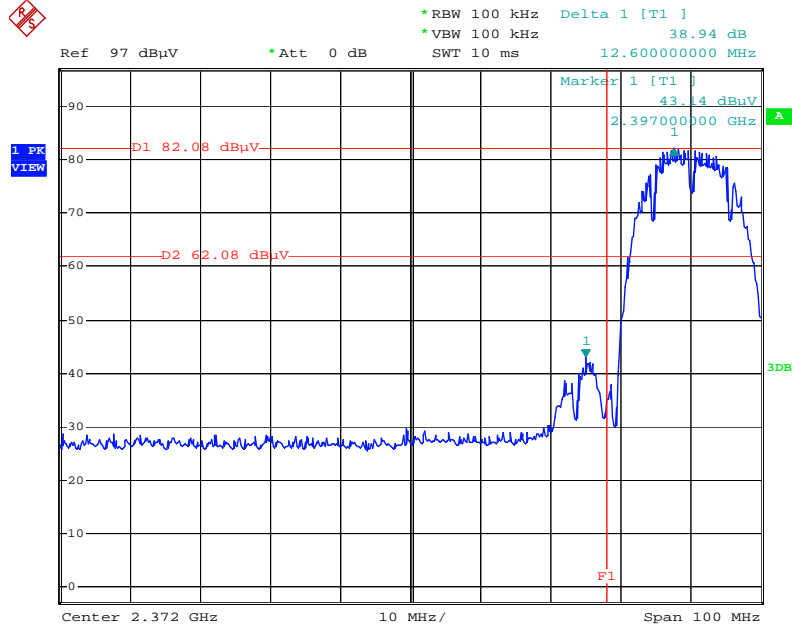

Date: 16.JUN.2011 00:11:18

High Band Edge Plot on Configuration IEEE 802.11b / Ant. 1 / 2462 MHz

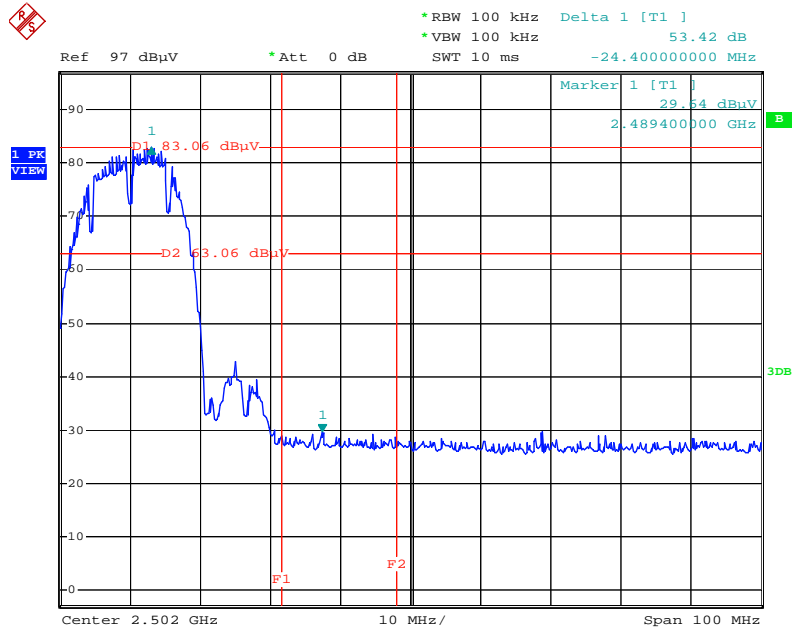

Date: 16.JUN.2011 02:19:37

Low Band Edge Plot on Configuration IEEE 802.11g / Ant. 1 / 2412 MHz

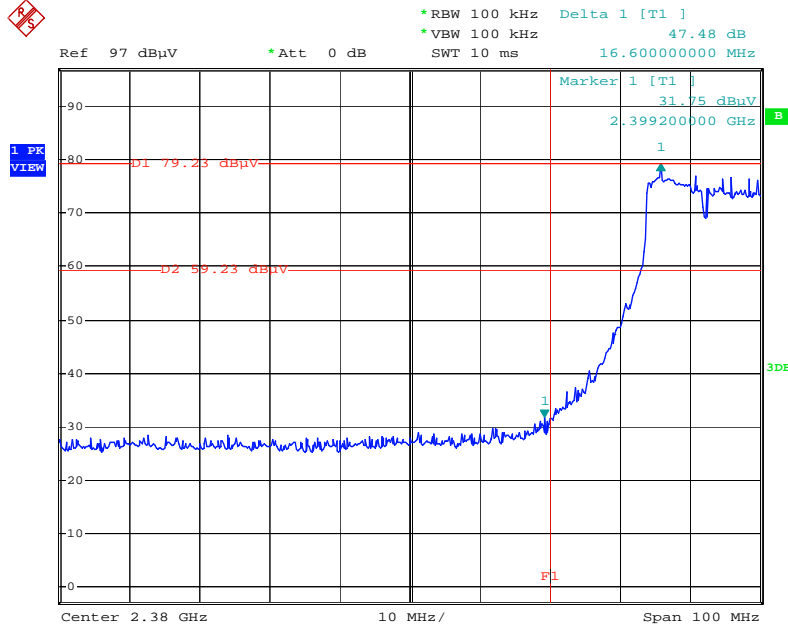

Date: 16.JUN.2011 02:40:53

High Band Edge Plot on Configuration IEEE 802.11g / Ant. 1 / 2462 MHz

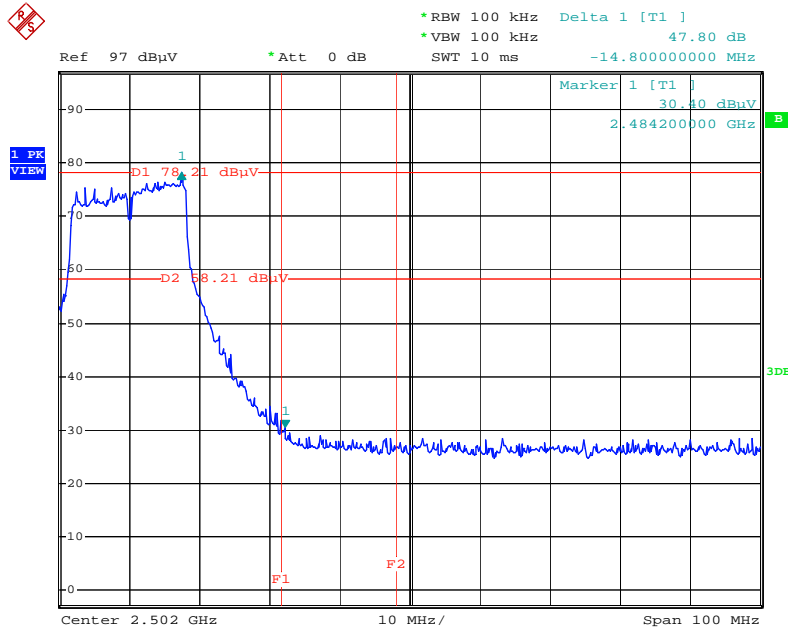

Date: 16.JUN.2011 02:22:39

For Emission not in Restricted Band

<For Ant. 2>

Low Band Edge Plot on Configuration IEEE 802.11n MCS0 20MHz / Ant. 2 / 2412 MHz

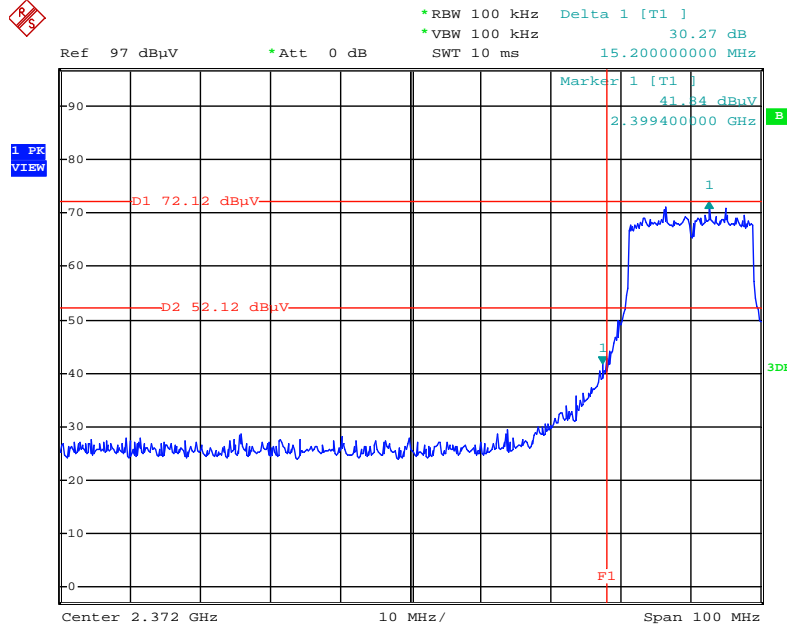

Date: 15.JUN.2011 19:25:38

High Band Edge Plot on Configuration IEEE 802.11n MCS0 20MHz / Ant. 2 / 2462 MHz

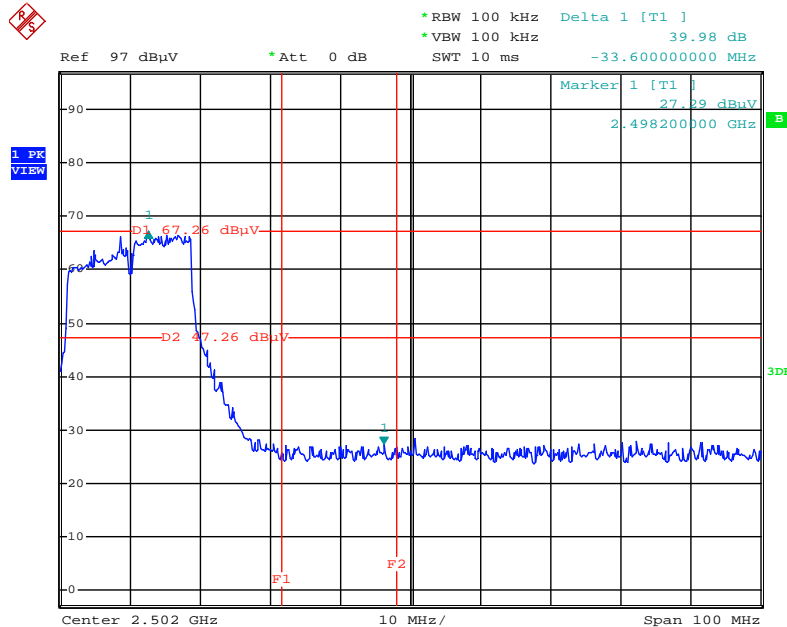

Date: 15.JUN.2011 19:41:05

Low Band Edge Plot on Configuration IEEE 802.11n MCS0 40MHz / Ant. 2 / 2422 MHz

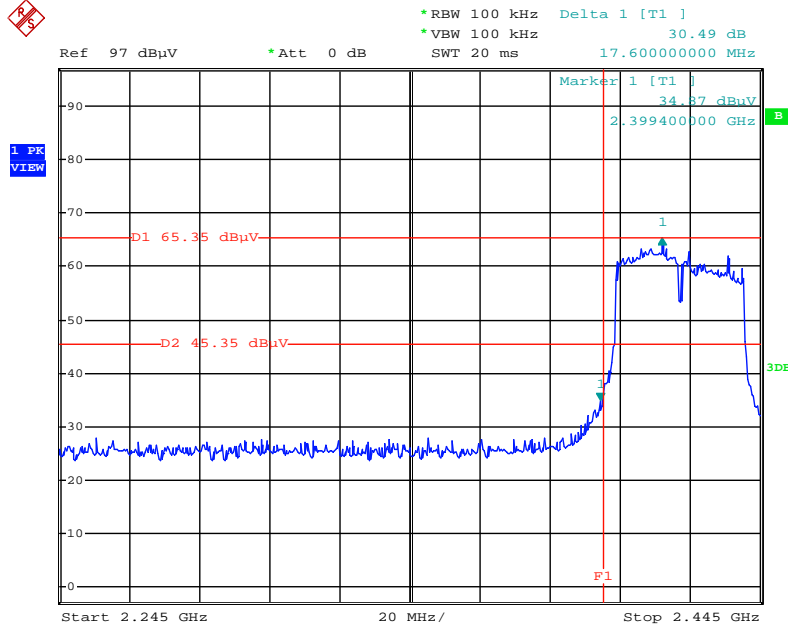

Date: 15.JUN.2011 19:29:56

High Band Edge Plot on Configuration IEEE 802.11n MCS0 40MHz / Ant. 2 / 2452 MHz

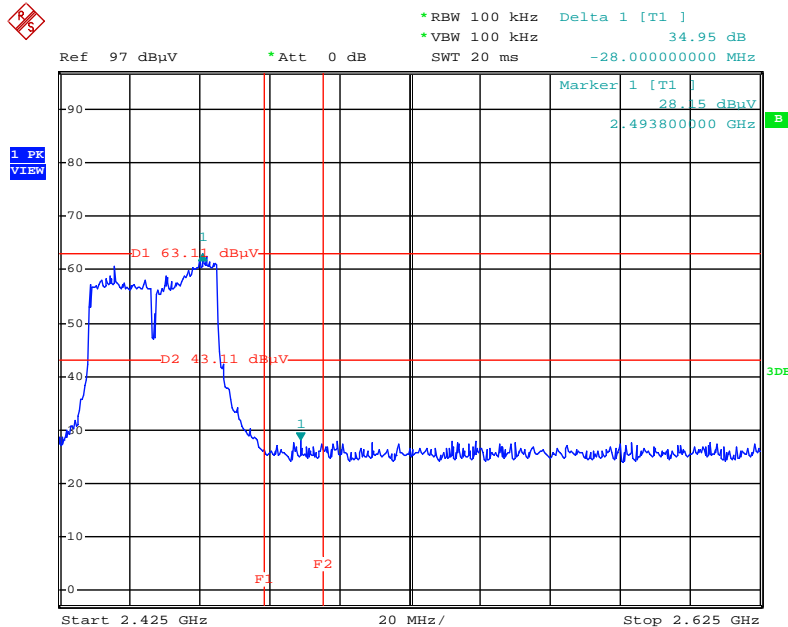

Date: 15.JUN.2011 19:43:36

Low Band Edge Plot on Configuration IEEE 802.11b / Ant. 2 / 2412 MHz

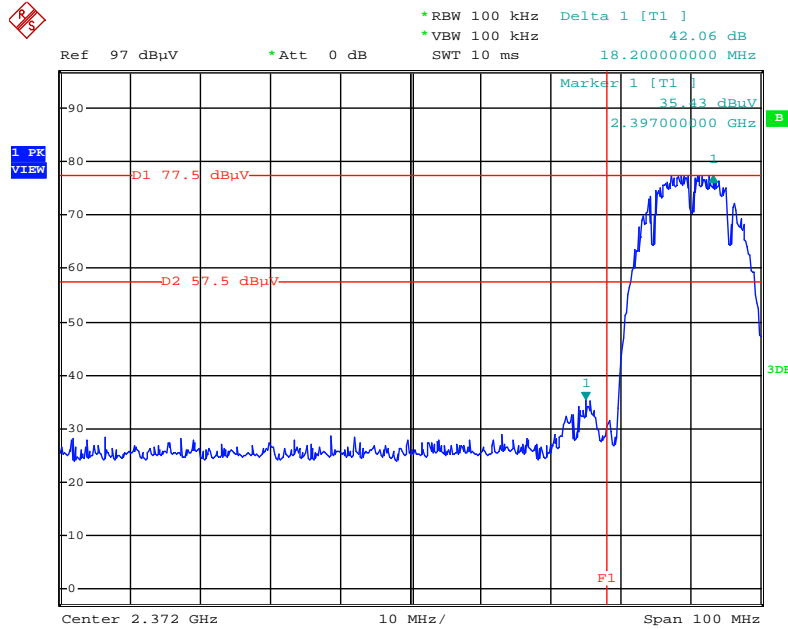

Date: 15.JUN.2011 19:14:08

High Band Edge Plot on Configuration IEEE 802.11b / Ant. 2 / 2462 MHz

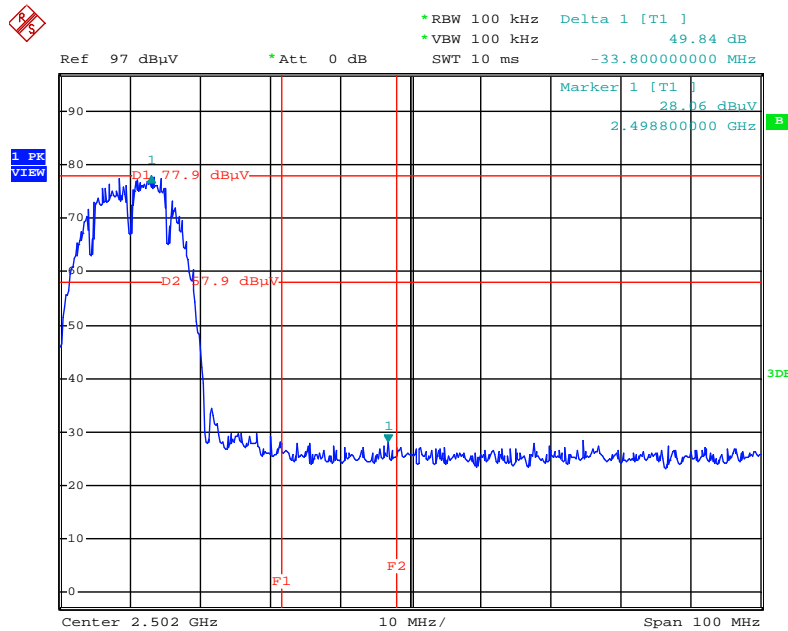

Date: 15.JUN.2011 19:34:40

Low Band Edge Plot on Configuration IEEE 802.11g / Ant. 2 / 2412 MHz

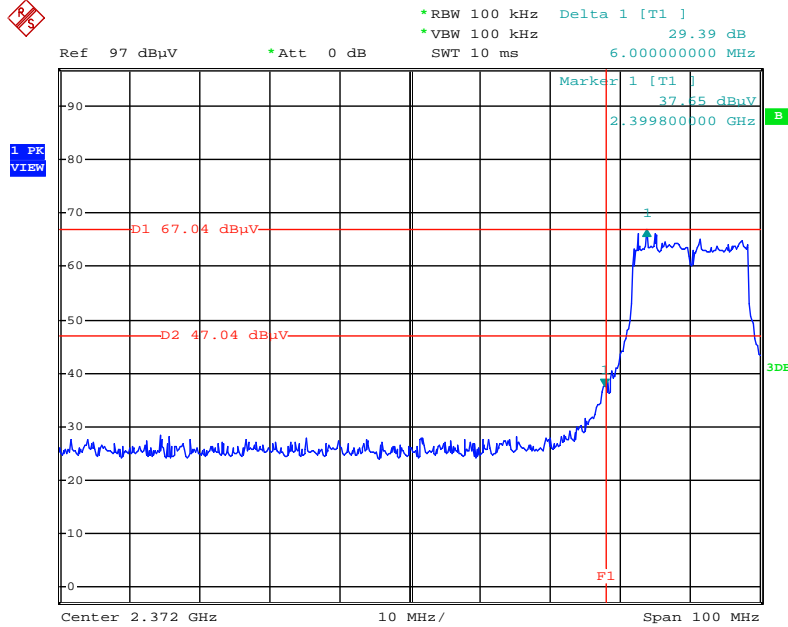

Date: 15.JUN.2011 19:22:36

High Band Edge Plot on Configuration IEEE 802.11g / Ant. 2 / 2462 MHz

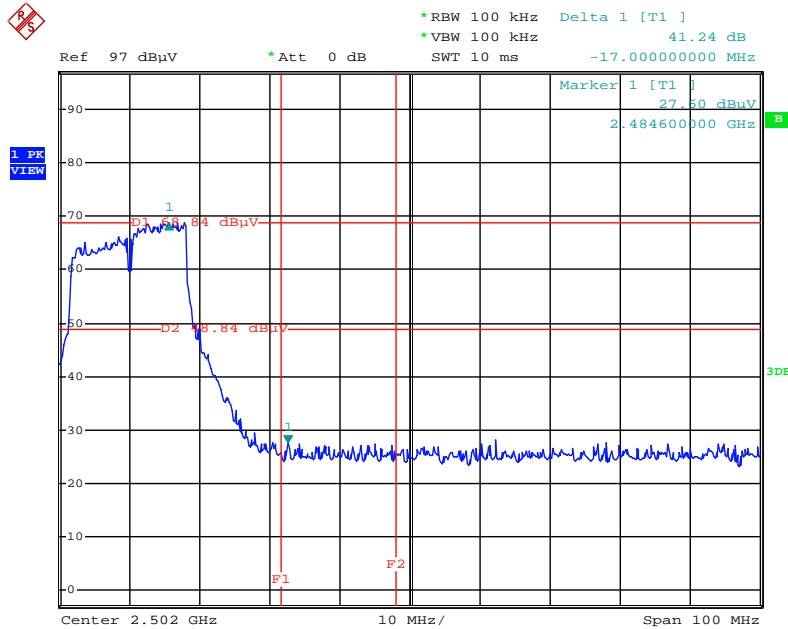

Date: 15.JUN.2011 19:37:46

For Emission not in Restricted Band

<For Ant. 3>

Low Band Edge Plot on Configuration IEEE 802.11n MCS0 20MHz / Ant. 3 / 2412 MHz

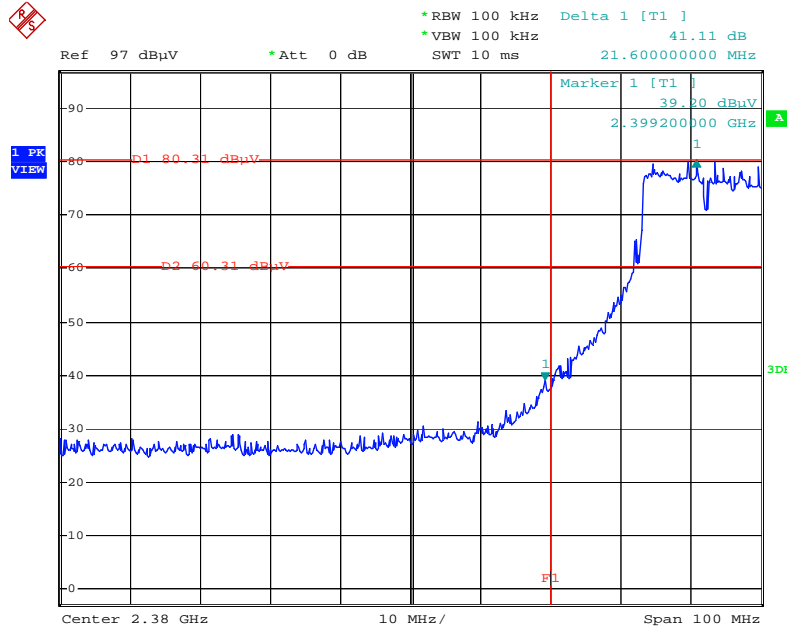

Date: 16.JUN.2011 22:52:20

High Band Edge Plot on Configuration IEEE 802.11n MCS0 20MHz / Ant. 3 / 2462 MHz

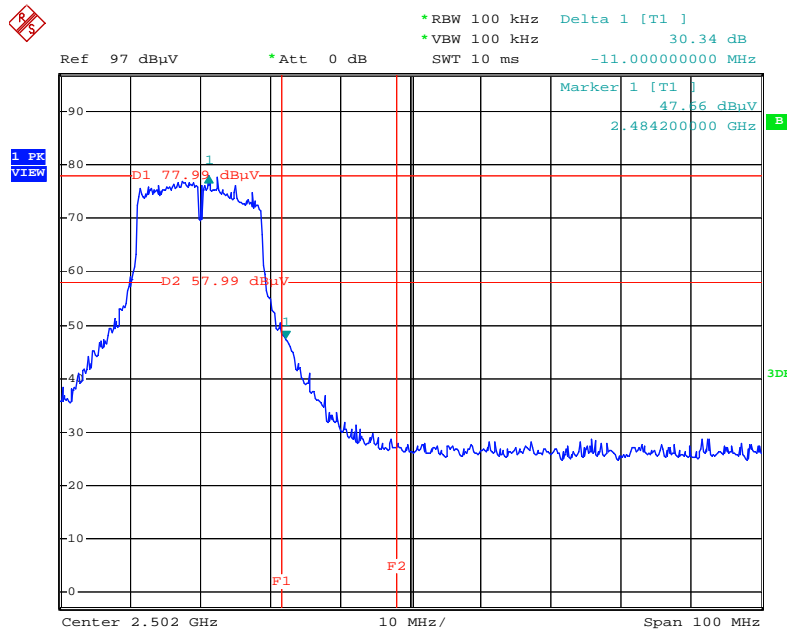

Date: 16.JUN.2011 22:54:42

Low Band Edge Plot on Configuration IEEE 802.11n MCS0 40MHz / Ant. 3 / 2422 MHz

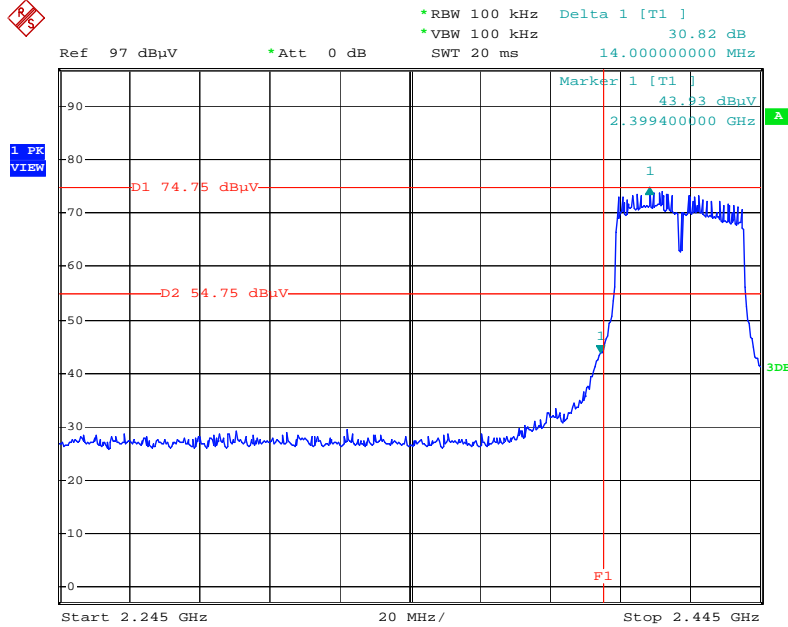

Date: 16.JUN.2011 23:01:55

High Band Edge Plot on Configuration IEEE 802.11n MCS0 40MHz / Ant. 3 / 2452 MHz

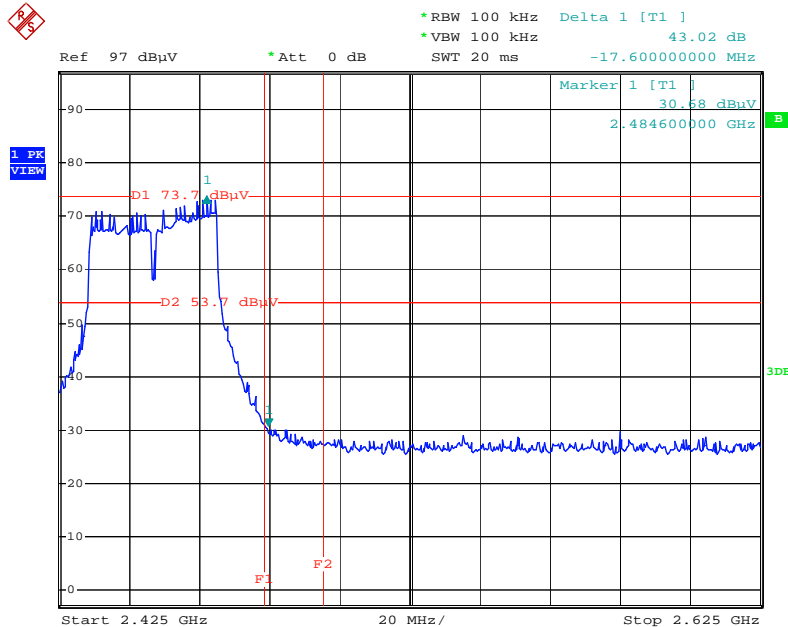

Date: 16.JUN.2011 22:58:18

Low Band Edge Plot on Configuration IEEE 802.11b / Ant. 3 / 2412 MHz

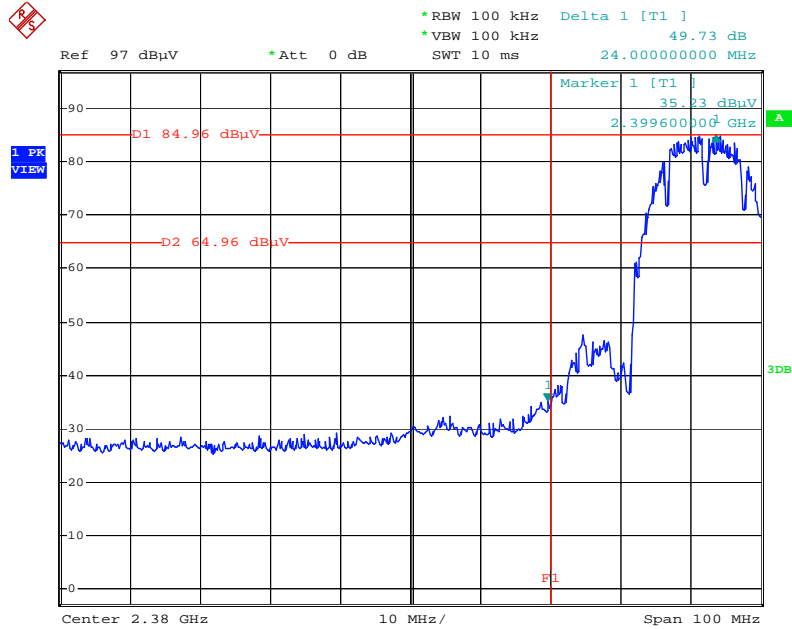

Date: 16.JUN.2011 20:56:38

High Band Edge Plot on Configuration IEEE 802.11b / Ant. 3 / 2462 MHz

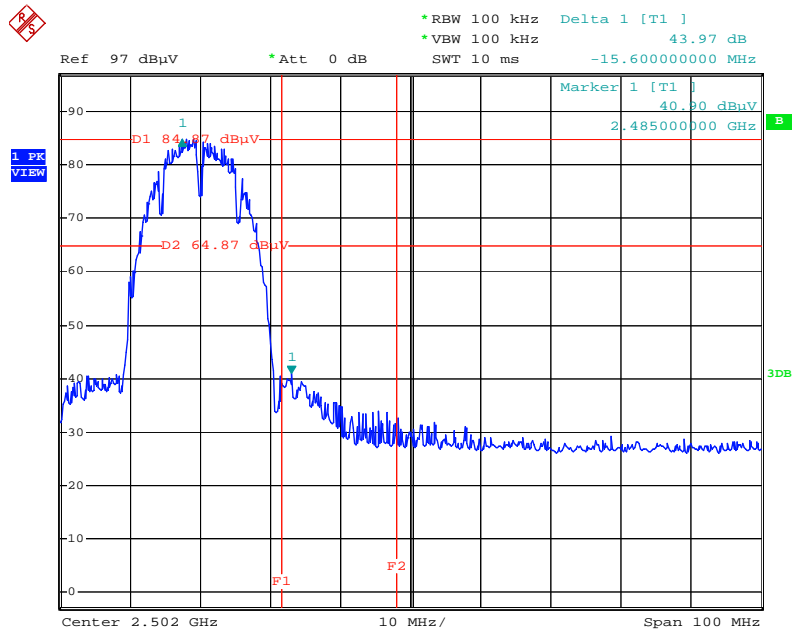

Date: 16.JUN.2011 22:42:52

Low Band Edge Plot on Configuration IEEE 802.11g / Ant. 3 / 2412 MHz

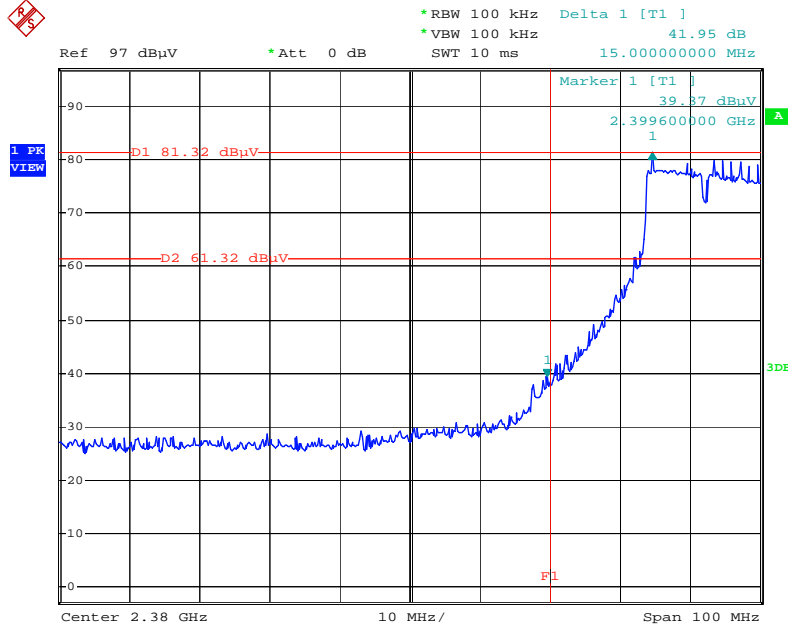

Date: 16.JUN.2011 22:49:09

High Band Edge Plot on Configuration IEEE 802.11g / Ant. 3 / 2462 MHz

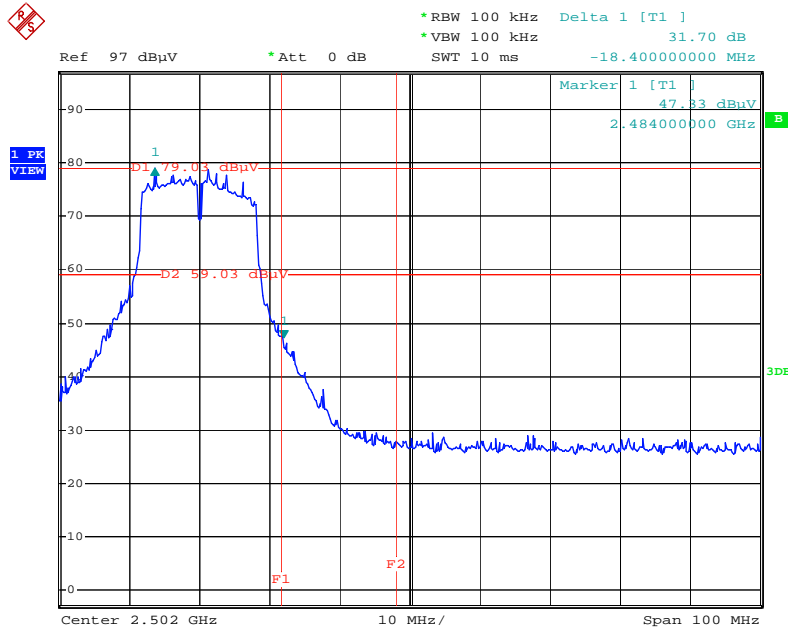

Date: 16.JUN.2011 22:47:05

For Emission not in Restricted Band

<For Ant. 4>

Low Band Edge Plot on Configuration IEEE 802.11n MCS0 20MHz / Ant. 4 / 2412 MHz

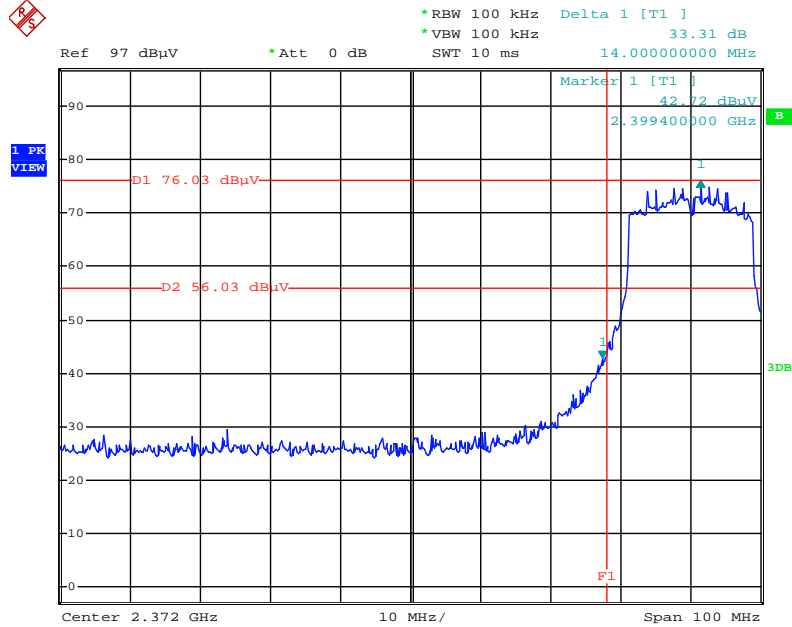

Date: 15.JUN.2011 18:41:03

High Band Edge Plot on Configuration IEEE 802.11n MCS0 20MHz / Ant. 4 / 2462 MHz

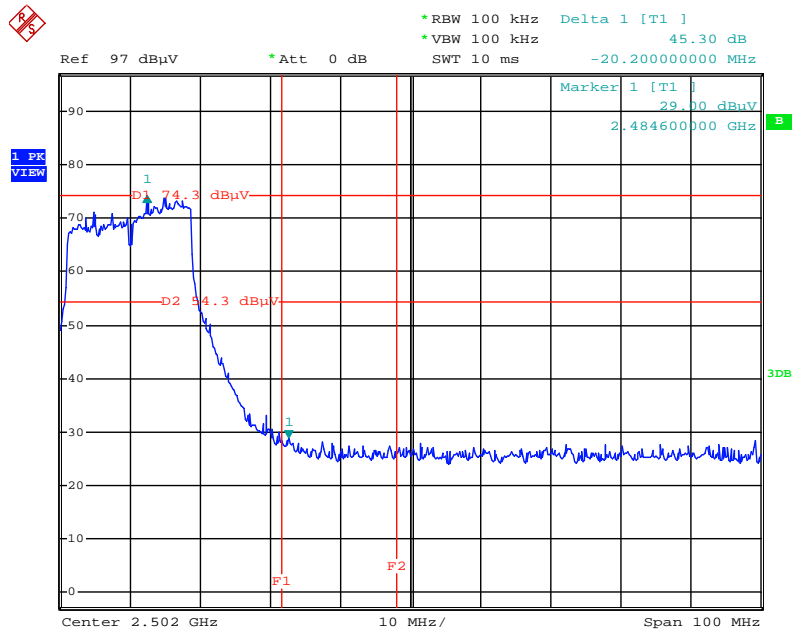

Date: 15.JUN.2011 18:59:47

Low Band Edge Plot on Configuration IEEE 802.11n MCS0 40MHz / Ant. 4 / 2422 MHz

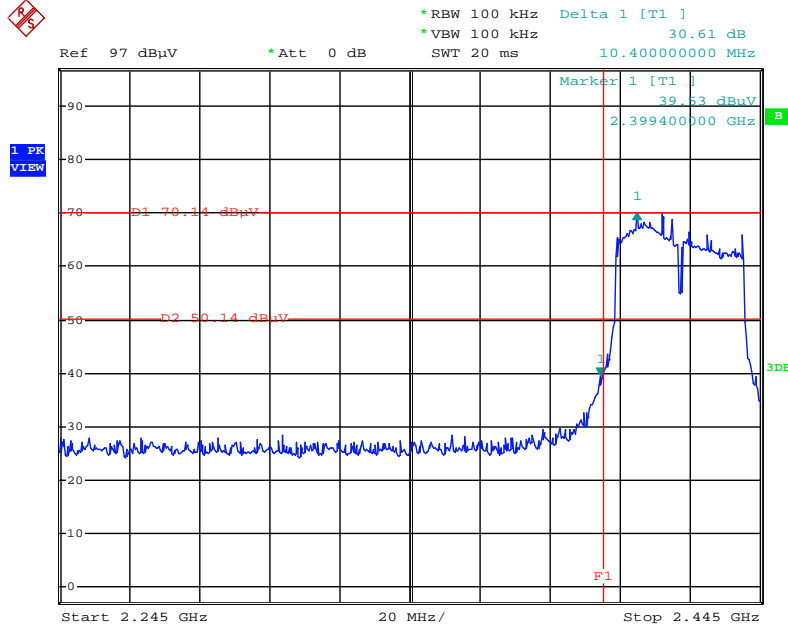

Date: 15.JUN.2011 18:47:14

High Band Edge Plot on Configuration IEEE 802.11n MCS0 40MHz / Ant. 4 / 2452 MHz

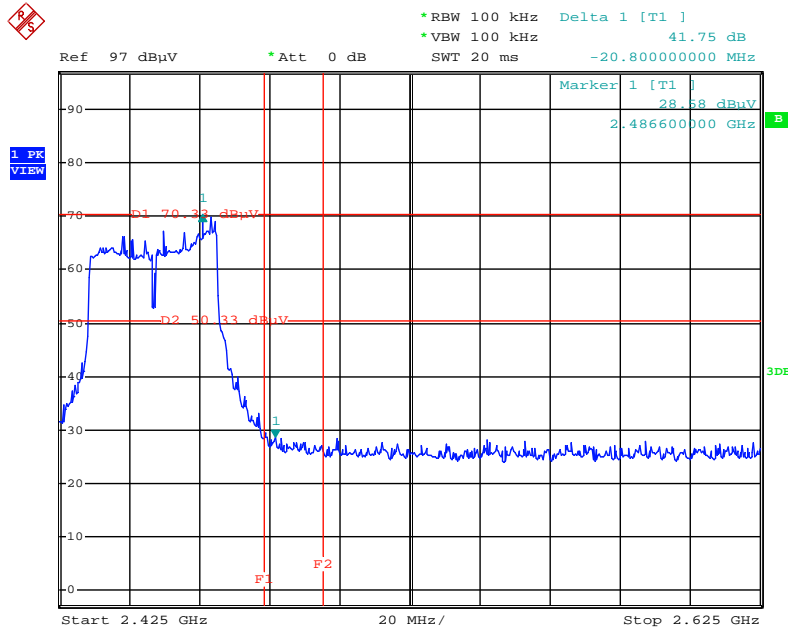

Date: 15.JUN.2011 19:03:11

Low Band Edge Plot on Configuration IEEE 802.11b / Ant. 4 / 2412 MHz

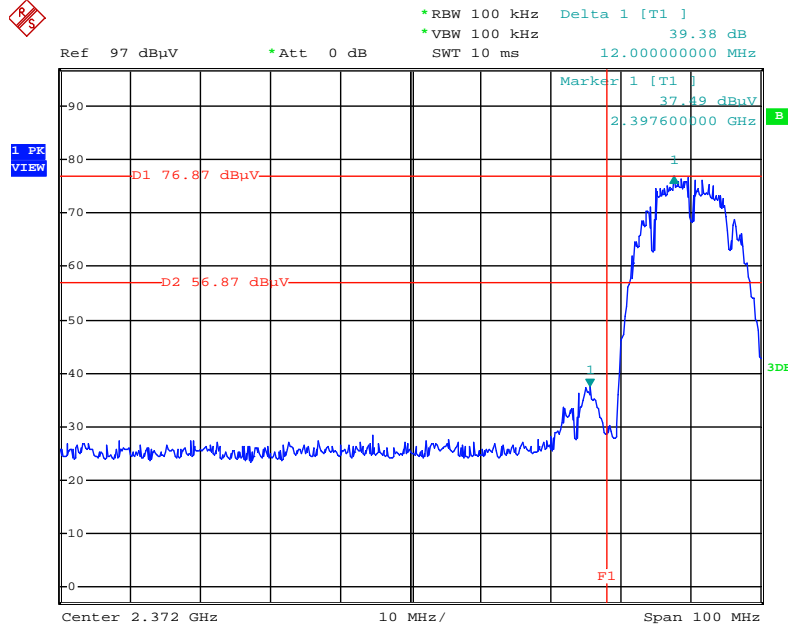

Date: 15.JUN.2011 18:35:04

High Band Edge Plot on Configuration IEEE 802.11b / Ant. 4 / 2462 MHz

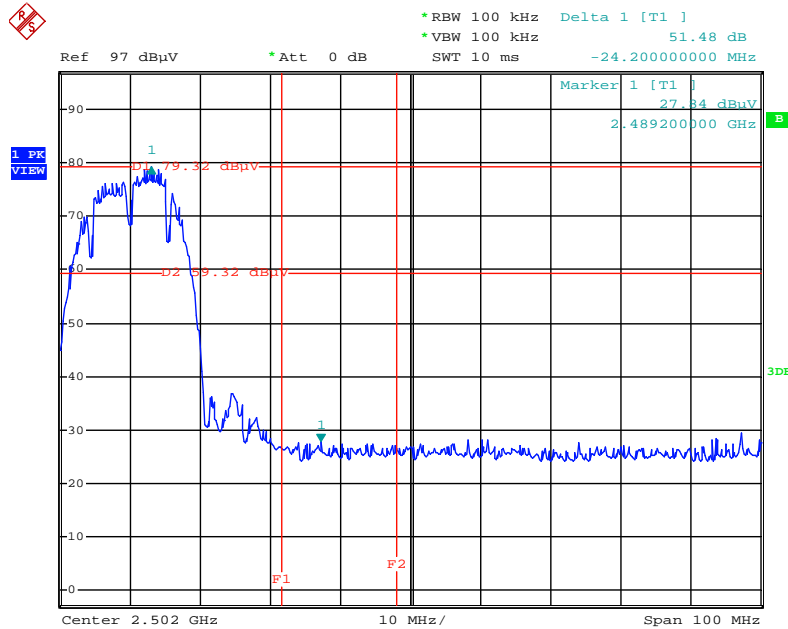

Date: 15.JUN.2011 18:51:58

Low Band Edge Plot on Configuration IEEE 802.11g / Ant. 4 / 2412 MHz

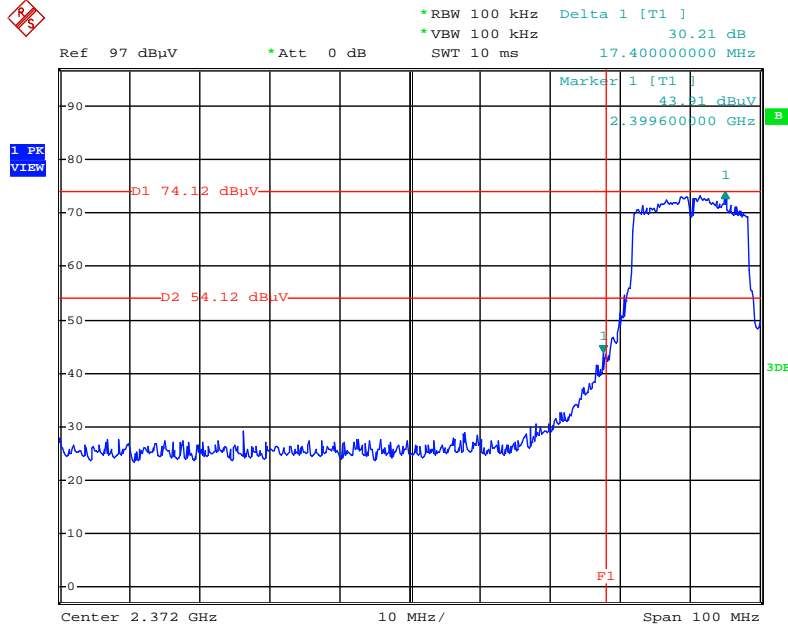

Date: 15.JUN.2011 18:37:49

High Band Edge Plot on Configuration IEEE 802.11g / Ant. 4 / 2462 MHz

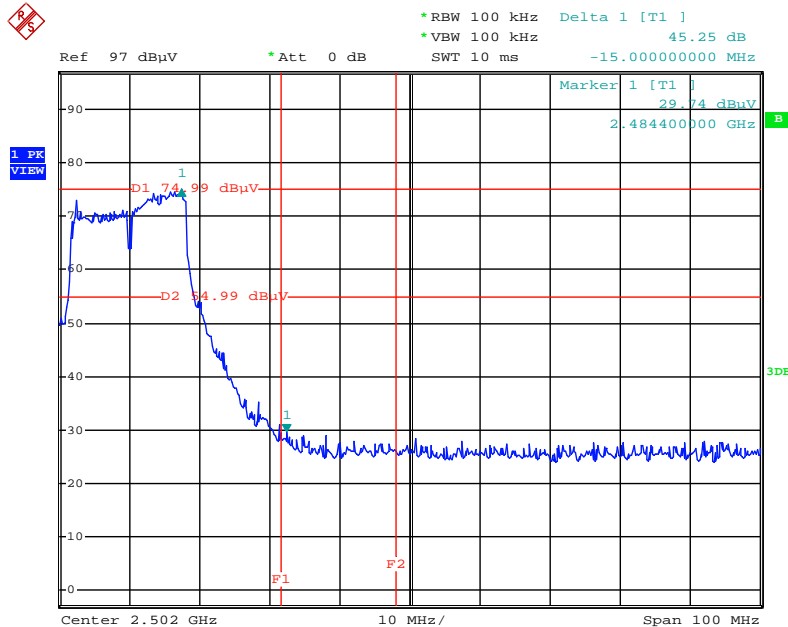

Date: 15.JUN.2011 18:54:59

For Emission not in Restricted Band

<For Ant. 5>

Low Band Edge Plot on Configuration IEEE 802.11n MCS0 20MHz / Ant. 5 / 2412 MHz

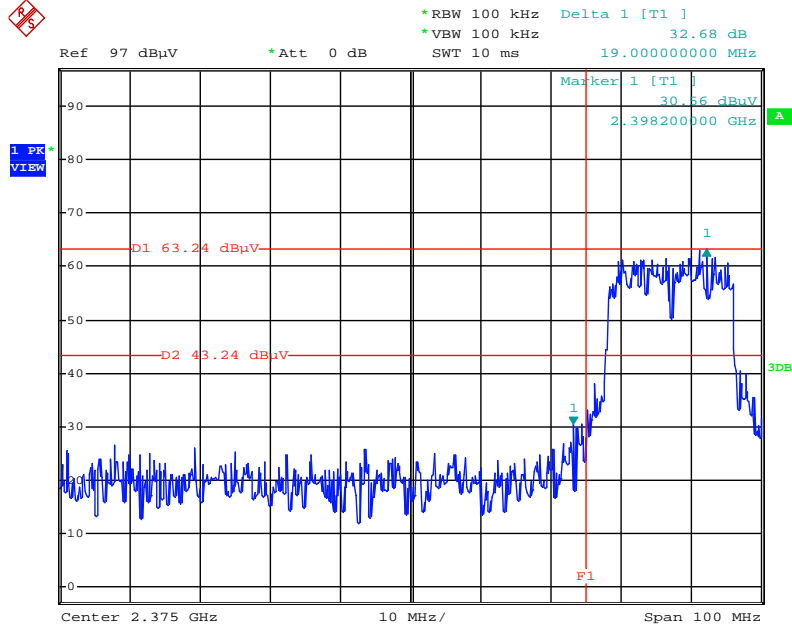

Date: 30.JUL.2011 17:52:40

High Band Edge Plot on Configuration IEEE 802.11n MCS0 20MHz / Ant. 5 / 2462 MHz

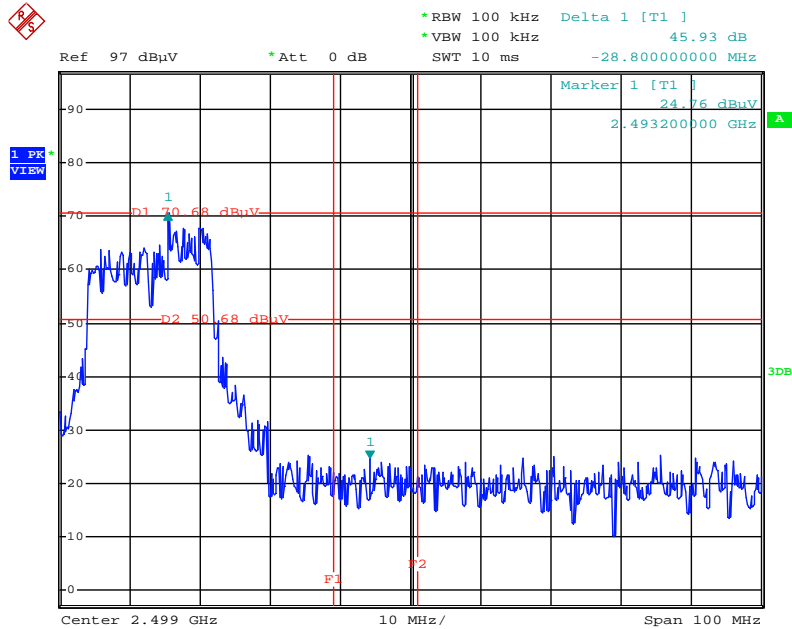

Date: 30.JUL.2011 18:14:37

Low Band Edge Plot on Configuration IEEE 802.11n MCS0 40MHz / Ant. 5 / 2422 MHz

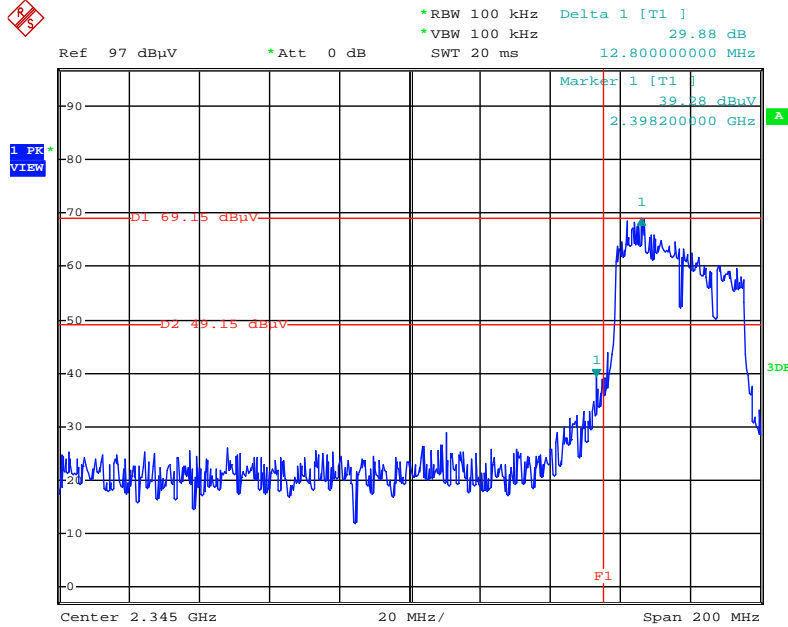

Date: 30.JUL.2011 18:01:54

High Band Edge Plot on Configuration IEEE 802.11n MCS0 40MHz / Ant. 5 / 2452 MHz

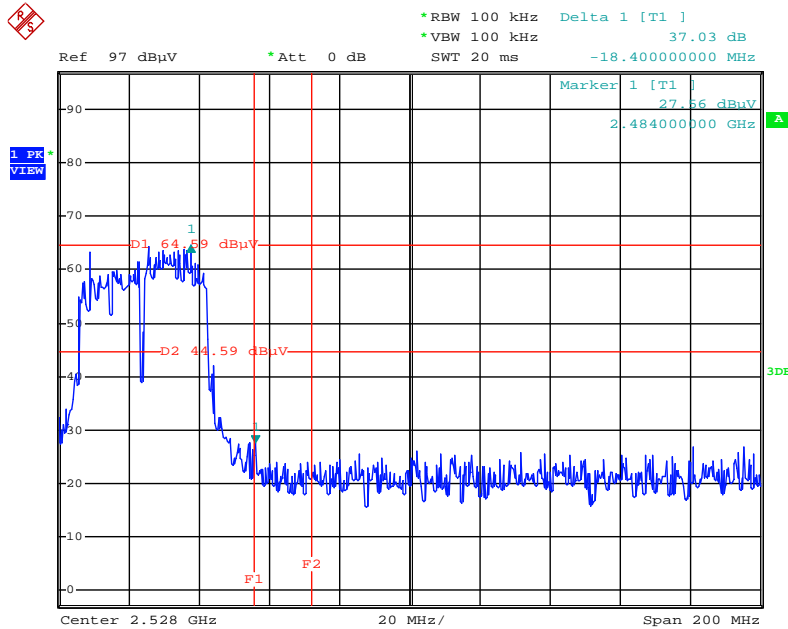

Date: 30.JUL.2011 18:05:14

Low Band Edge Plot on Configuration IEEE 802.11b / Ant. 5 / 2412 MHz

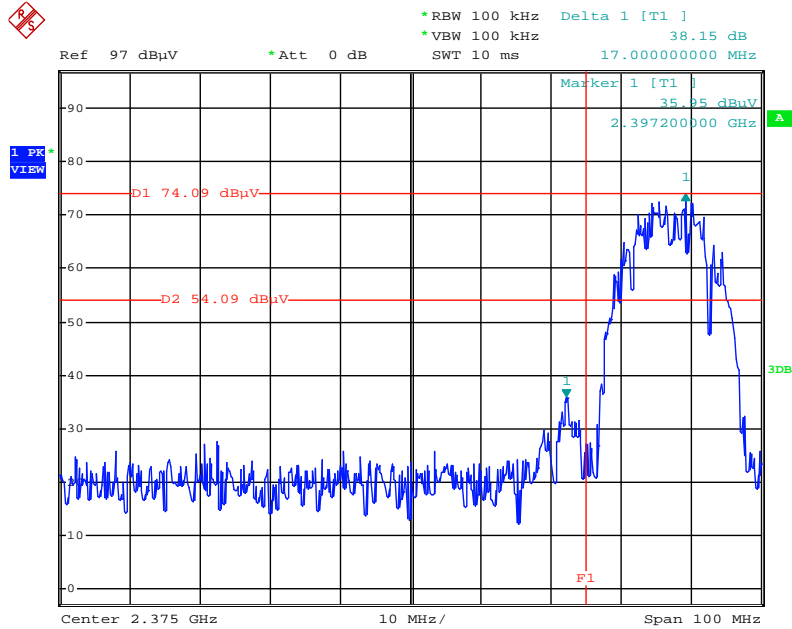

Date: 30.JUL.2011 17:56:50

High Band Edge Plot on Configuration IEEE 802.11b / Ant. 5 / 2462 MHz

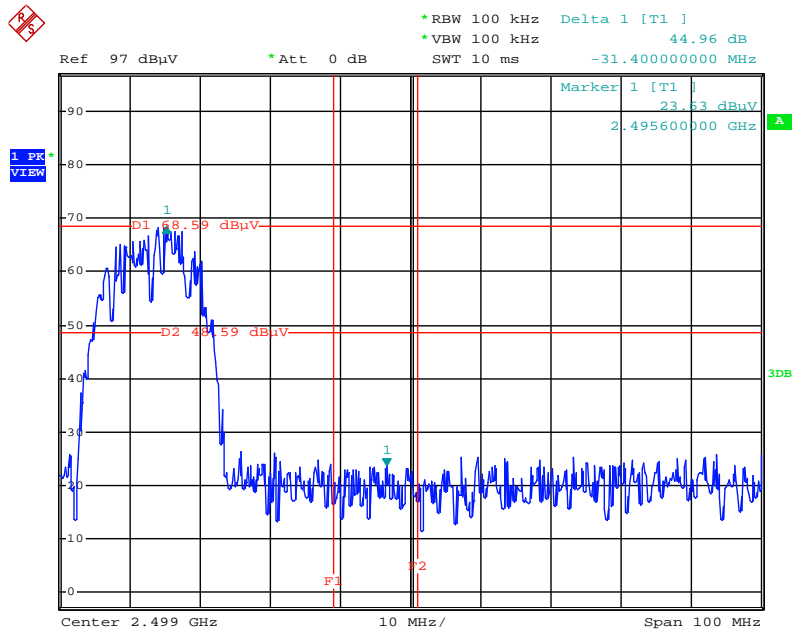

Date: 30.JUL.2011 18:13:08

Low Band Edge Plot on Configuration IEEE 802.11g / Ant. 5 / 2412 MHz

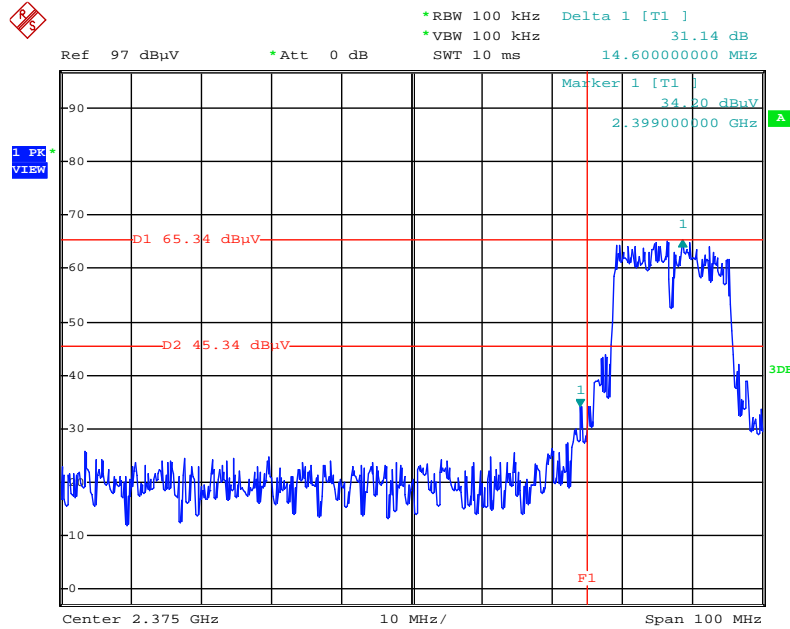

Date: 30.JUL.2011 17:55:10

High Band Edge Plot on Configuration IEEE 802.11g / Ant. 5 / 2462 MHz

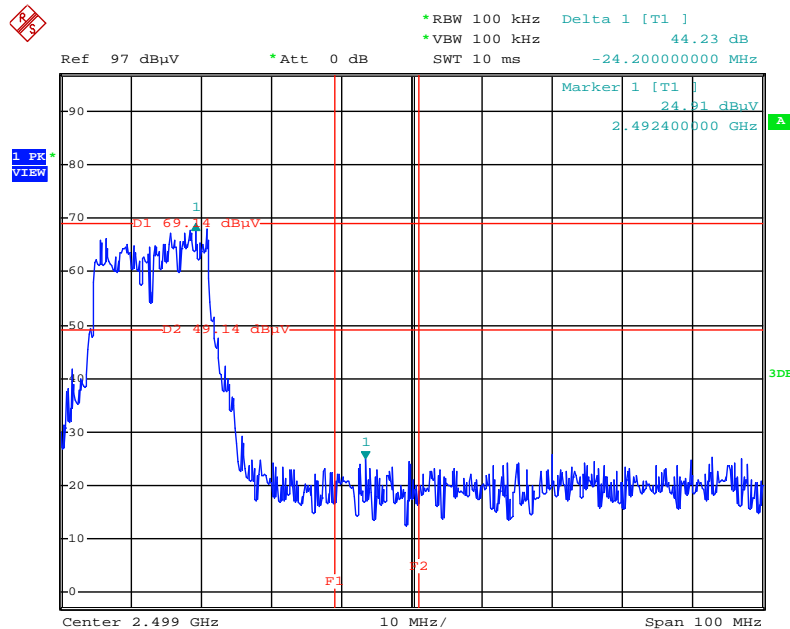

Date: 30.JUL.2011 18:09:03

4.7. Antenna Requirements

4.7.1. Limit

Except for special regulations, the Low-power Radio-frequency Devices must not be equipped with any jacket for installing an antenna with extension cable. An intentional radiator shall be designed to ensure that no antenna other than that furnished by the responsible party shall be used with the device. The use of a permanently attached antenna or of an antenna that uses a unique coupling to the intentional radiator shall be considered sufficient to comply with the provisions of this Section. The manufacturer may design the unit so that the user can replace a broken antenna, but the use of a standard antenna jack or electrical connector is prohibited. Further, this requirement does not apply to intentional radiators that must be professionally installed.

4.7.2. Antenna Connector Construction

Please refer to section 3.3 in this test report; antenna connector complied with the requirements.

5. LIST OF MEASURING EQUIPMENTS

Instrument	Manufacturer	Model No.	Serial No.	Characteristics	Calibration Date	Remark
EMI Test Receiver	R&S	ESCS 30	100377	9kHz ~ 2.75GHz	Sep. 01,2010	Conduction (CO01-CB)
LISN	F.C.C.	FCC-LISN-50-16-2	04083	150kHz ~ 100MHz	Oct. 28,2010	Conduction (CO01-CB)
V- LISN	Schwarzbeck	NSLK 8127	8127-478	9K ~ 30MHz	Nov. 16, 2010	Conduction (CO01-CB)
PULSE LIMITER	R&S	ESH3-Z2	100430	9K~30MHz	Jan. 04, 2011	Conduction (CO01-CB)
COND Cable	-	Cable	-	0.15MHz~30MHz	Dec. 04, 2010	Conduction (CO01-CB)
BILOG ANTENNA	Schaffner	CBL6112D	22021	20MHz ~ 2GHz	Oct. 17, 2010	Radiation (03CH01-CB)
Horn Antenna	EMCO	3115	00075790	750MHz~18GHz	Nov. 22, 2010	Radiation (03CH01-CB)
Horn Antenna	SCHWARZBEAK	BBHA 9170	BBHA9170252	15GHz ~ 40GHz	Oct. 08, 2010	Radiation (03CH01-CB)
Pre-Amplifier	Agilent	8447D	2944A10991	0.1MHz ~ 1.3GHz	Nov. 17, 2010	Radiation (03CH01-CB)
Pre-Amplifier	Agilent	8449B	3008A02310	1GHz ~ 26.5GHz	Nov. 23, 2010	Radiation (03CH01-CB)
Pre-Amplifier	WM	TF-130N-R1	923365	26.5GHz ~ 40GHz	Nov. 17, 2010	Radiation (03CH01-CB)
Spectrum analyzer	R&S	FSP	100304	9kHz ~ 40GHz	Nov. 22, 2010	Radiation (03CH01-CB)
EMI Test Receiver	R&S	ESCS 30	100355	9KHz ~ 2.75GHz	Mar. 22, 2011	Radiation (03CH01-CB)
Loop Antenna	Teseq	HLA 6120	24155	9 kHz - 30 MHz	Sep. 09, 2010*	Radiation (03CH01-CB)
Turn Table	INN CO	CO 2000	N/A	0 ~ 360 degree	N/A	Radiation (03CH01-CB)
Antenna Mast	INN CO	CO2000	N/A	1 m - 4 m	N/A	Radiation (03CH01-CB)
RF Cable-low	Woken	Low Cable-1	N/A	30 MHz - 1 GHz	Nov. 17, 2010	Radiation (03CH01-CB)
RF Cable-high	Woken	High Cable-1	N/A	1 GHz – 26.5 GHz	Nov. 17, 2010	Radiation (03CH01-CB)
RF Cable-high	Woken	High Cable-2	N/A	1 GHz – 26.5 GHz	Nov. 17, 2010	Radiation (03CH01-CB)
RF Cable-high	Woken	High Cable-3	N/A	1 GHz - 40 GHz	Nov. 17, 2010	Radiation (03CH01-CB)
RF Cable-high	Woken	High Cable-4	N/A	1 GHz - 40 GHz	Nov. 17, 2010	Radiation (03CH01-CB)
Spectrum analyzer	R&S	FSV30	101026	9KHz~30GHz	Jul. 23, 2011	Conducted (TH01-CB)
Temp. and Humidity Chamber	Ten Billion	TTH-D3SP	TBN-931011	-30~100 degree	May 20, 2011	Conducted (TH01-CB)
Thermo-Hygro Meter	N/A	HC 520	#1	15~70 degree	Nov. 02, 2010	Conducted (TH01-CB)
RF Power Divider	HP	11636A	00306	2GHz ~ 18GHz	N/A	Conducted (TH01-CB)
RF Power Splitter	Anaren	44100	1839	2GHz ~ 18GHz	N/A	Conducted (TH01-CB)

Instrument	Manufacturer	Model No.	Serial No.	Characteristics	Calibration Date	Remark
RF Power Splitter	Anaren	42100	17930	2GHz ~ 18GHz	N/A	Conducted (TH01-CB)
RF Cable-high	Woken	High Cable-7	-	1 GHz – 26.5 GHz	Nov. 17, 2010	Conducted (TH01-CB)
RF Cable-high	Woken	High Cable-8	-	1 GHz – 26.5 GHz	Nov. 17, 2010	Conducted (TH01-CB)
RF Cable-high	Woken	High Cable-9	-	1 GHz – 26.5 GHz	Nov. 17, 2010	Conducted (TH01-CB)
RF Cable-high	Woken	High Cable-10	-	1 GHz – 26.5 GHz	Nov. 17, 2010	Conducted (TH01-CB)
RF Cable-high	Woken	High Cable-11	-	1 GHz – 26.5 GHz	Nov. 17, 2010	Conducted (TH01-CB)
RF Cable-high	Woken	High Cable-12	-	1 GHz – 26.5 GHz	Nov. 17, 2010	Conducted (TH01-CB)
RF Cable-high	Woken	High Cable-13	-	1 GHz – 26.5 GHz	Nov. 17, 2010	Conducted (TH01-CB)
Power Sensor	Anritsu	MA2411B	0917223	300MHz~40GHz	Sep. 13, 2010	Conducted (TH01-CB)
Power Meter	Anritsu	ML2495A	1035008	300MHz~40GHz	Sep. 08, 2010	Conducted (TH01-CB)

Note: Calibration Interval of instruments listed above is one year.

Note: *Calibration Interval of instruments listed above is two year.

6. TEST LOCATION

SHIJR	ADD : 6Fl., No. 106, Sec. 1, Shintai 5th Rd., Shijr City, Taipei, Taiwan 221, R.O.C. TEL : 886-2-2696-2468 FAX : 886-2-2696-2255
HWA YA	ADD : No. 52, Hwa Ya 1st Rd., Kwei-Shan Hsiang, Tao Yuan Hsien, Taiwan, R.O.C. TEL : 886-3-327-3456 FAX : 886-3-318-0055
LINKOU	ADD : No. 30-2, Dingfu Tsuen, Linkou Shiang, Taipei, Taiwan 244, R.O.C TEL : 886-2-2601-1640 FAX : 886-2-2601-1695
DUNGHU	ADD : No. 3, Lane 238, Kangle St., Neihu Chiu, Taipei, Taiwan 114, R.O.C. TEL : 886-2-2631-4739 FAX : 886-2-2631-9740
JUNGHE	ADD : 7Fl., No. 758, Jungjeng Rd., Junghe City, Taipei, Taiwan 235, R.O.C. TEL : 886-2-8227-2020 FAX : 886-2-8227-2626
NEIHU	ADD : 4Fl., No. 339, Hsin Hu 2 nd Rd., Taipei 114, Taiwan, R.O.C. TEL : 886-2-2794-8886 FAX : 886-2-2794-9777
JHUBEI	ADD : No.8, Lane 724, Bo-ai St., Jhubei City, HsinChu County 302, Taiwan, R.O.C. TEL : 886-3-656-9065 FAX : 886-3-656-9085

7. TAF CERTIFICATE OF ACCREDITATION



Certificate No. : L1190-091230

財團法人全國認證基金會
Taiwan Accreditation Foundation

Certificate of Accreditation

This is to certify that

Sporton International Inc.
EMC & Wireless Communications Laboratory
No.52, Hwa Ya 1st Rd., Hwa Ya Technology Park, Kwei-Shan Hsiang, Tao Yuan Hsien,
Taiwan, R.O.C.

is accredited in respect of laboratory

Accreditation Criteria	: ISO/IEC 17025:2005
Accreditation Number	: 1190
Originally Accredited	: December 15, 2003
Effective Period	: January 10, 2010 to January 09, 2013
Accredited Scope	: Testing Field, see described in the Appendix
Specific Accreditation Program	: Accreditation Program for Designated Testing Laboratory for Commodities Inspection Accreditation Program for Telecommunication Equipment Testing Laboratory Accreditation Program for BSMI Mutual Recognition Arrangement with Foreign Authorities

Jay-san Chen

Jay-San Chen
President, Taiwan Accreditation Foundation
Date : December 30, 2009

Pl, total 22 pages

The Appendix forms an integral part of this Certificate, which shall be invalid when use without the Appendix