

# ***Measurement Report***

*Product*.....: *Keyboard*  
*Manufacture*.....: *SOLID YEAR CO., LTD*  
*FCC ID*.....: *L2BACEKEY100U*  
*Model*.....: *ACK-100U*  
*Report No.*.....: *MLT9909P15001*  
*Test Date*.....: *September 21.1999*

*Test By*

**Max Light Technology Co.,Ltd.**  
*Room 5, 8F, No.125, Section 3 Roosevelt Road,*  
*Taipei, Taiwan., R.O.C.*  
**Tel: 886-2-2363-2447 Fax: 886-2-2363-2597**

**The test report consists of 20 pages in total. It may be duplicated completely for legal use with the allowance of the applicant. It shall not be reproduced except in full, without the written approval of our laboratory.**



# **MAX LIGHT**

## **MEASUREMENT REPORT**

### **Table of Contents :**

<b><i>I. General</i></b> .....	<b>4</b>
<b><i>II. Conducted Emissions Requirements</i></b> .....	<b>8</b>
<b><i>III. Radiated Emissions Requirements</i></b> .....	<b>14</b>
<b><i>Appendix I (EUT Test Setup)</i></b> .....	<b>20</b>



# MAX LIGHT

## MEASUREMENT REPORT

Page: 3/20

### CERTIFICATION

We here by verify that :

The test data, data evaluation, test procedures and equipment configurations shown in this report were made in accordance with the procedures given in ANSI C63.4-1992. All test were conducted by MLT (Max Light Technology Co.,Ltd) Room 5, 8F, No.125, Section 3 Roosevelt Road, Taipei, Taiwan, R.O.C Also, we attest to the accuracy of each.

We further submit that the energy emitted by the sample EUT tested as described in the report is in compliance with Class B radiated and conducted emission limit of FCC Rules Part 15 Subpart B.



**EUT** : Keyboard

**Applicant** : SOLID YEAR CO., LTD  
NO.3 PAO CHI LANE, CHUANG YA TSUN,  
SIU SHUI HSIANG, CHANGHWA HSIEN,  
TAIWAN R.O.C

**Manufacturer** : SOLID YEAR CO., LTD  
NO.3 PAO CHI LANE, CHUANG YA TSUN,  
SIU SHUI HSIANG, CHANGHWA HSIEN,  
TAIWAN R.O.C

**Model No** : ACK-100U

**FCC ID** : L2BACEKEY100U

Prepared by :  Approved by :   
Country Huang Roger Chen



# **MAX LIGHT**

## **MEASUREMENT REPORT**

Page: 4/20

### **I. GENERAL**

#### **1.1 Introduction**

The following measurement report is submitted on behalf of **SOLID YEAR CO., LTD.** In support of a **Class B Digital Device** certification in accordance with **Part2 Subpart J** and **Part 15 Subpart A and B** of the Commission's Rules and Regulations.

#### **1.2 Description of EUT**

**EUT** : **Keyboard**

**Applicant** : **SOLID YEAR CO., LTD**  
**NO.3 PAO CHI LANE, CHUANG YA TSUN,**  
**SIU SHUI HSIANG, CHANGHWA HSIEN,**  
**TAIWAN R.O.C**

**Manufacturer** : **SOLID YEAR CO., LTD**  
**NO.3 PAO CHI LANE, CHUANG YA TSUN,**  
**SIU SHUI HSIANG, CHANGHWA HSIEN,**  
**TAIWAN R.O.C**

**Model No** : **ACK-100U**

**FCC ID** : **L2BACEKEY100U**

**Power Type** : **5V DC form host computer.**

**USB Cable** : **USB connectorx1(Shielded, 83 cm long)**

The Keyboard is designed for PC system. EUT is the Windows 98 enhanced keyboard. During testing the EUT(Keyboard)was using the EMI-TEST software to set at Keyboard Test mode for each emission measured . This was done in order to ensure that maximum emission levels were attained.



# MAX LIGHT

## MEASUREMENT REPORT

### 1.3 Description of Support Equipment

In order to construct the minimum system which required by the ANSI C63.4-1991, following equipments were used as the support units.

*Computer* : **COMPAQ**  
**Model No.** : **3284**  
**Serial No.** : **L708BKTB4154**  
**FCC ID** : **EJH3284**

*Monitor* : **COMPAQ**  
**Model No.** : **303U**  
**Serial No.** : **704AG19TG099**  
**FCC ID** : **BJMCM14UH**

*Printer* : **PANASONIC**  
**Model No.** : **KX-P1080I**  
**Serial No.** : **7CKAKE98933**  
**FCC ID** : **ACJ5Z6KX-P10801**

*Mouse* : **COMPAQ**  
**Model No.** : **MZE4**  
**Serial No.** : **97033491**  
**FCC ID** : **FSUGMZE4**

*Modem* : **Askey (External Fax / Data Modem)**  
**Model No.** : **WS1414VE**  
**Serial No.** : **IAH-10811**  
**FCC ID** : **H8N1414VE**

*Keyboard* : **COMPAQ**  
**Model No.** : **KPQ-E99ZC-13**  
**Serial No.** : **237743-334**  
**FCC ID** : **CMYKPQ7285**

### 1.4 Configuration of System Under Test

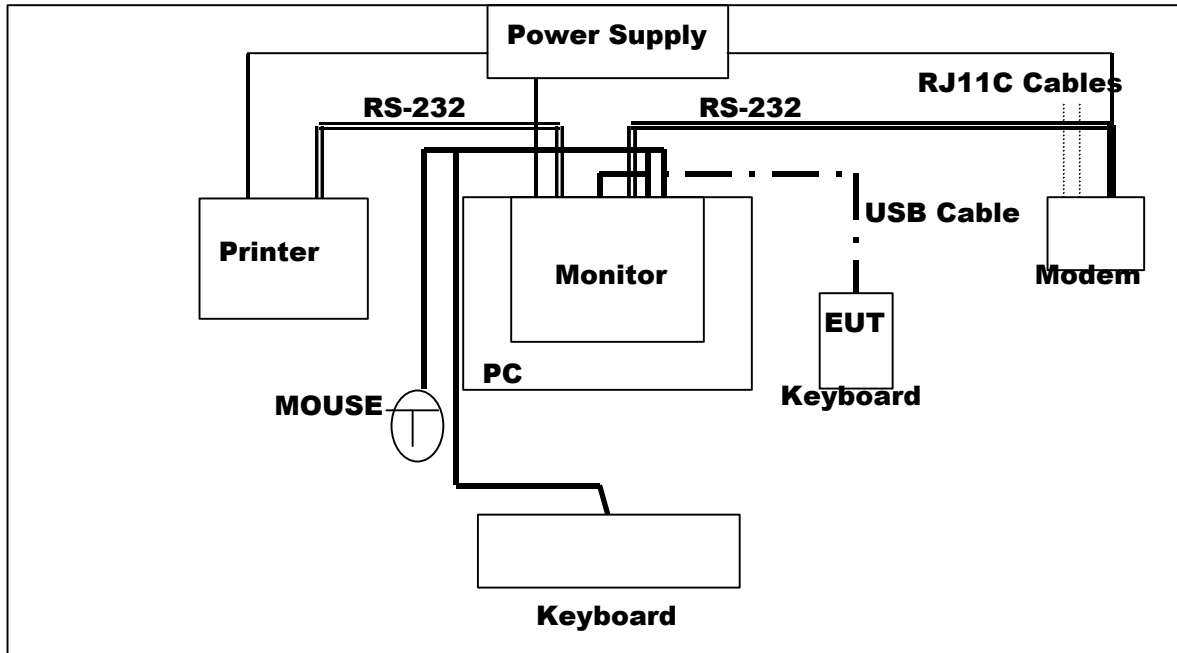

During testing the EUT(Keyboard) was connected to the Compaq PC's USB port. So there is no need for additional I/O card. A keyboard was connected to PS/2 port and A mouse was connected to other PS/2 port. A modem was connected to the series port and a printer was connected to the parallel port. Two telephone line(RJ11C cables) connected to the Phone Jack of modem and the Line Jack of modem.

### 1.5 Test Procedure

All measurements contained in this report were performed according to the techniques described in Measurement procedure ANSI C63.4-1992 "Measurement of unintentional Radiators."



# **MAX LIGHT**

## **MEASUREMENT REPORT**

Page: 7/20

### **1.6 General Test Condition**

**The conditions under which the EUT operates were varied to determine their effect on the equipment's emission characteristics. The final configuration of the test system and the mode of operation used during these tests were chosen as that which produced the highest emission levels. However, only those conditions, which the EUT was considered likely to encounter in normal use, were investigated. The system's radiated and conducted emissions were investigated.**



## ***II. Conducted Emissions Requirements***

### **2.1 General & Setup :**

**The power line conducted emission measurements were performed in a shielded enclosure. The EUT was assembled on a wooden table which is 80 centimeters high, was placed 40 centimeters from the backwall and at least 1 meter from the sidewall.**

**Power was fed to the EUT from the public utility power grid through a line filter and EMC0 Model 3825/2 Line Impedance Stabilization Networks (LISN). The LISN housing, measuring instrumentation case, ground plane, etc., were electrically bonded together at the same RF potential. The Spectrum analyzer was connected to the AC line through an isolation transformer. The 50-ohm output of the LISN was connected to the spectrum analyzer directly. Conducted emission levels were in the CISPER quasi-peak detection mode. The analyzer's 6 dB bandwidth was set to 9 KHz. No post-detector video filter was used.**

**The spectrum was scanned from 450 KHz to 30 MHz. The physical arrangement of the test system and associated cabling was varied (within the scope of arrangements likely to be encountered in actual use) to determine the effect on the unit's emanations in amplitude and frequency. All spurious emission frequencies were observed. The highest emission amplitudes relative to the appropriate limit were measured and have been recorded in paragraph 2.6.**

### **2.2 Test Equipment List:**

- A. EMC0 3825/2 LISN (S/N:2654)**
- B. EMC0 3825/2 LISN (S/N:2658)**
- C. HP 8591EM 9KHZ-1.8GHz Spectrum Analyzer (S/N:73412A00110)**
- D. Shielded Room (MLT-SR1)**



### **2.3 Test Configuration:**



**Rear View of The Test Configuration**

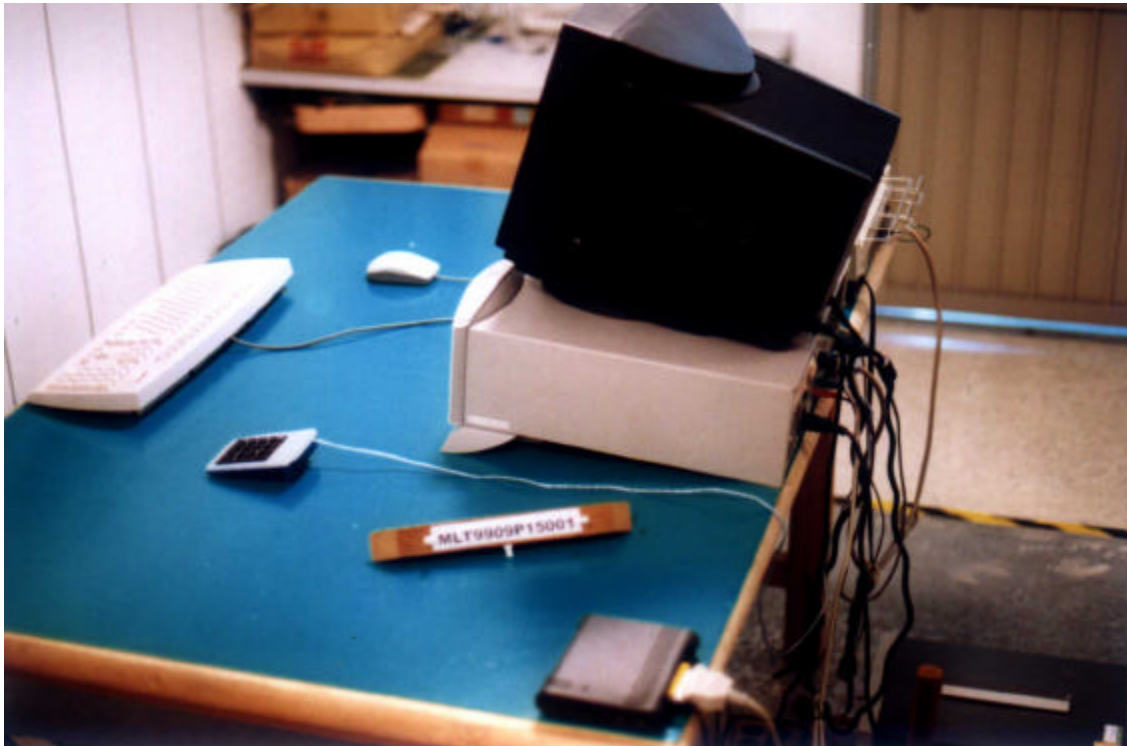

**Rear View of The Test Configuration**



# **MAX LIGHT**

## **MEASUREMENT REPORT**

### **2.4 Test condition:**

**EUT tested in accordance with the specifications given by the manufacturer , and exercised in the most unfavorable manner.**

### **2.5 Conducted Emissions Limits:**

<i>Frequency range (MHz)</i>	<i>Limits (dBuV)</i>
0.45 to 30	47.9

**2.6 Measurement Data Of Conducted Emissions:**

The following table show a summary of the highest emissions of power line conducted emissions to the **HOT** and **NATURAL** conductor of the **EUT** power.

Manufacturer : SOLID YEAR CO., LTD  
 Model No : ACK-100U  
 EUT : Keyboard

<b>Power Line Conducted Emissions (Class B)</b>			
<b>Conductor</b>	<b>Frequency (MHz)</b>	<b>Peak Amplitude (dBuV)</b>	<b>Limits (dBuV)</b>
<b>L1</b>	0.45	31.27	47.9
	9.56	33.65	47.9
	13.01	34.98	47.9
	16.67	36.37	47.9
	19.58	37.83	47.9
	23.65	33.61	47.9
	29.99	32.22	47.9
<b>L2</b>	0.45	30.85	47.9
	9.56	34.72	47.9
	13.01	35.03	47.9
	16.67	35.76	47.9
	19.58	37.40	47.9
	23.65	32.99	47.9
	29.99	33.13	47.9

Notes : 1.L1: One end & Ground L2: The other end & Ground  
 2.Height of table on which the EUT was placed : 0.8 m.  
 3.The above test results are obtained under the normal condition.



### ***III. Radiated Emissions Requirements***

#### **3.1 General & Setup :**

Prior to open-field testing, the EUT was placed in a shielded enclosure and scanned at a close distance to determine its emission characteristics. The physical arrangement of the EUT was varied (within the scope of arrangements likely to be encountered in actual use) to determine the effect on the unit's emanations in amplitude, directivity, and frequency. The exact system configuration which produced the highest emissions was noted so it could be reproduced later during the open-field tests. This was done to ensure that the final measurements would demonstrate the worst-case interference potential of the EUT. Final radiation measurements were made on a three-meter, open-field test site. The EUT system was placed on a nonconductive turntable which is 0.8 meters height, top surface 1.0 x 1.5 meter. The spectrum was examined from 30 MHz to 1000 MHz using an Hewlett Packard 8591EM Spectrum Analyzer, EMCO Biconical Antenna (Model 3142) for 30-1000MHz. At each frequency, the EUT was rotated 360 degrees, and the antenna was raised and lowered from one to four meters to find the maximum emission levels. Measurements were taken using both horizontal and vertical antenna polarization. Appropriate preamplifiers were used for improving sensitivity and precautions were taken to avoid overloading or desensitizing the spectrum analyzer. No post-detector video filters were used in the test. The spectrum analyzer's 6 dB bandwidth was set to 120 KHz, and the analyzer was operated in the quasi-peak detection mode. The highest emission amplitudes relative to the appropriate limit were measured and recorded in paragraph 3.6.

#### **3.2 Test Equipment List:**

- A. HP 8591EM 9KHz-1.8GHz Spectrum Analyzer (S/N:73412A00230)**
- B. HP 8447D Pre Amplifier (S/N:2944A08954)**
- C. EMCO 3142 Biconilog Antenna (S/N:1184)**
- D. HP 8590A 10KHz-1.5GHz Spectrum Analyzer (S/N:5212A000260U)**
- E. HP 9872B Plotter (S/N:20447A03436)**

### **3.3 Test Configuration:**



**Front View of The Test Configuration**



**Rear View of The Test Configuration**



# **MAX LIGHT**

## **MEASUREMENT REPORT**

### **3.4 Test condition:**

**EUT tested in accordance with the specifications given by the manufacturer , and exercised in the most unfavorable manner.**

### **3.5 Radiated Emissions Limits:**

<i>Frequency range (MHz)</i>	<i>Peak(dBuV)</i>
30 to 88	40
88 to 216	43.5
216 to 960	46
Above 960	54





# MAX LIGHT

## MEASUREMENT REPORT

### 3.6 Measurement Data Of Radiated Emissions:

#### 3.6.1 Open Field Radiated Emissions (HORIZONTAL)

The highest peak values of radiated emissions from the EUT at various antenna heights, antenna polarization, EUT orientation , etc. are recorded on the following

Manufacturer : SOLID YEAR CO., LTD  
Model No : ACK-100U  
EUT : Keyboard

Radiated Emissions (HORIZONTAL)					
Frequency (MHz)	Amplitude (dBuV/m)	Ant. (m)	Table (Degree)	Limits(Class B) (dBuV/m)	Margin (dB)
58.12	32.17	1	360	40	-7.83
73.33	33.55	1	360	40	-6.45
83.27	32.93	1.5	340	40	-7.07
126.81	37.12	1	360	43.5	-6.38
139.92	38.93	2	350	43.5	-4.57
187.64	36.42	1.5	340	43.5	-7.08
199.90	41.84	2	360	43.5	-1.66
236.93	39.21	1.5	300	46	-6.79
298.86	33.96	1	300	46	-12.04

- Notes :
1. **Margin= Amplitude - Limits**
  2. **Distance of Measurement : 3 Meter (30-1000MHz)**
  3. **Height of table for EUT placed: 0.8 Meter.**
  4. **ANT= Antenna height.**
  5. **Amplitude= Reading Amplitude -Amplifier gain+Cable loss +Antenna factor**  
**(Auto calculate in spectrum analyzer)**



# MAX LIGHT MEASUREMENT REPORT

### 3.6.2 Open Field Radiated Emissions (VERTICAL)

The highest peak values of radiated emissions from the EUT at various antenna heights, antenna polarization, EUT orientation , etc. are recorded on the following.

Manufacturer : SOLID YEAR CO., LTD.  
Model No : ACK-100U  
EUT : Keyboard

Radiated Emissions (VERTICAL)					
Frequency (MHz)	Amplitude (dBuV/m)	Ant. (m)	Table (Degree)	Limits(Class B) (dBuV/m)	Margin (dB)
58.12	35.83	1.5	270	40	-4.17
73.33	36.31	1	360	40	-3.69
83.27	34.62	1.5	300	40	-5.38
126.81	37.81	1	360	43.5	-5.69
139.92	39.43	1.5	300	43.5	-4.07
187.64	38.66	1	200	43.5	-4.84
199.90	40.91	1.5	300	43.5	-2.59
236.93	38.62	1	360	46	-7.38
298.86	33.41	1.5	270	46	-12.59

- Notes :
1. Margin= Amplitude - Limits
  2. Distance of Measurement : 3 Meter (30-1000MHz)
  3. Height of table for EUT placed: 0.8 Meter.
  4. ANT= Antenna height.
  5. Amplitude= Reading Amplitude –Amplifier gain+Cable loss +Antenna factor  
(Auto calculate in spectrum analyzer)

**Appendix I- EUT Test SETUP**

**MEASUREMENT OF POWER LINE CONDUCTED RFI VOLTAGE**

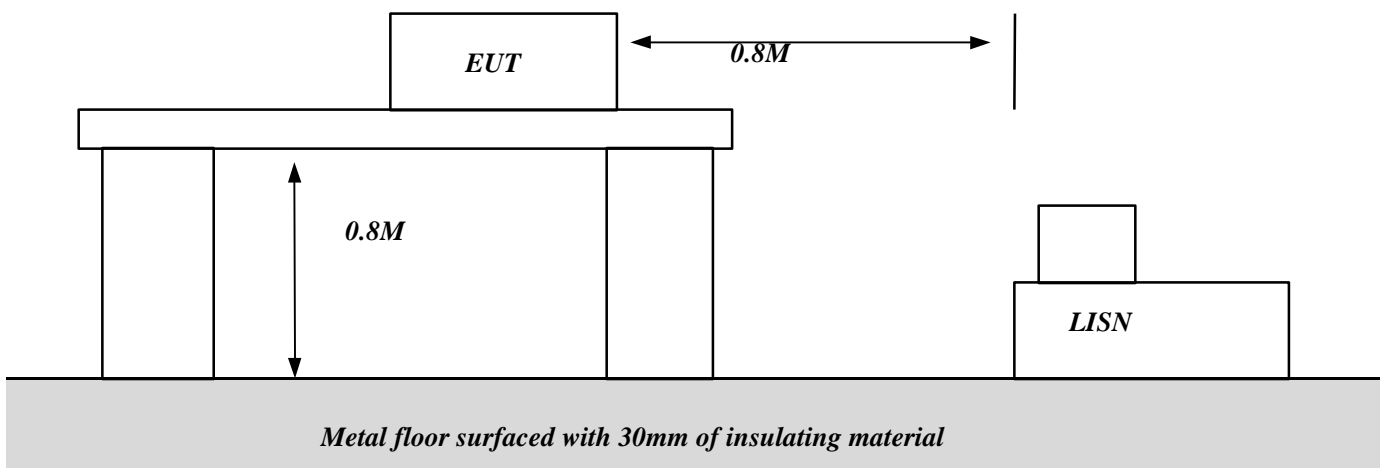

**Appendix I- EUT Test SETUP**

**MEASUREMENT OF RADIATED EMISSION**

