

# THE SERVICE MANUAL SK3133-PPQ



CE

VERSION: 180924\_V1

## TABLE OF CONTENTS

CIRCUIT .....	3
BLOCK DIAGRAM .....	4
THE DESCRIPTION .....	5-8
THE PCB LAYOUTS – Top & Bottom Sides .....	9
THE SILK SCREENS – Top & Bottom Sides .....	10

THE SILK SCREENS – TOP & BOTTOM SIDES

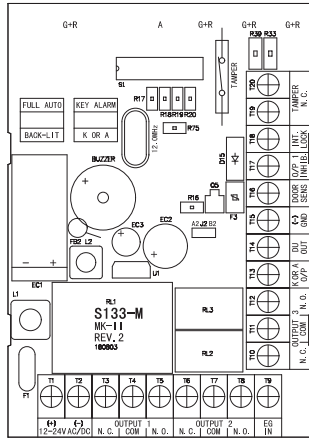

Top side silk screen

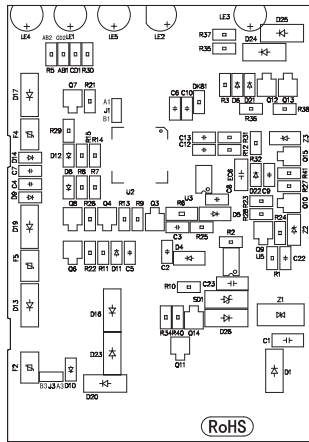

Bottom side silk screen

CIRCUIT

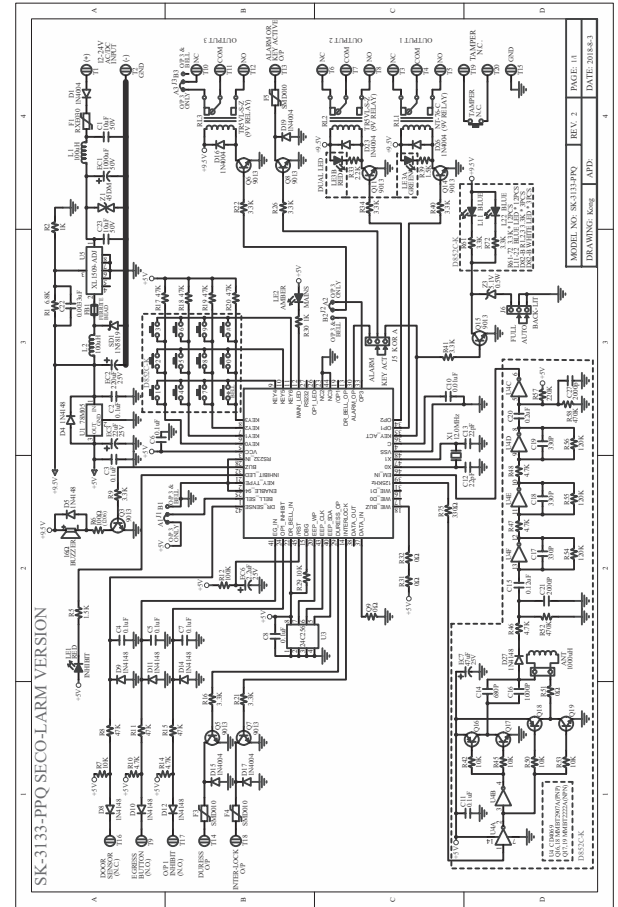

Figure 1 circuit diagram

**BLOCK DIAGRAM**

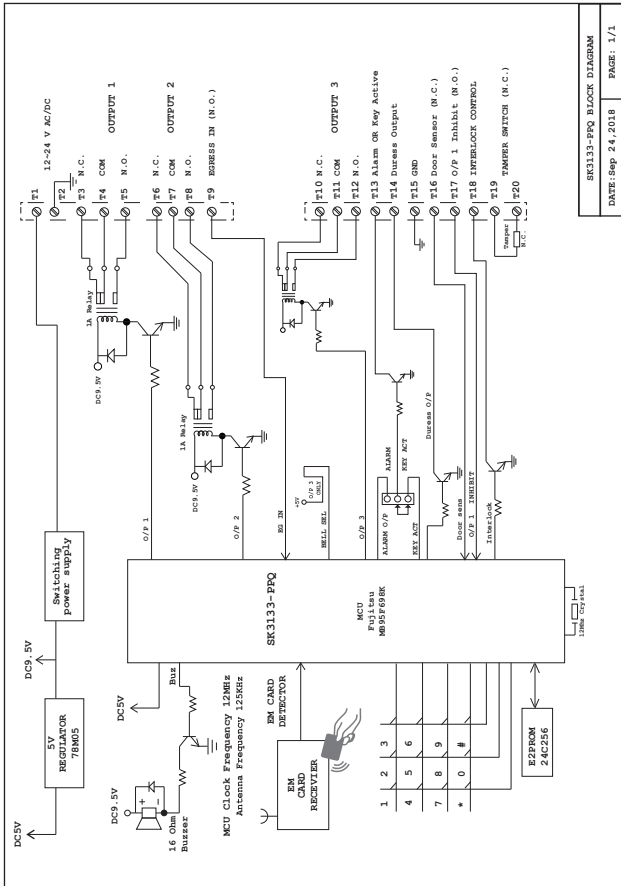
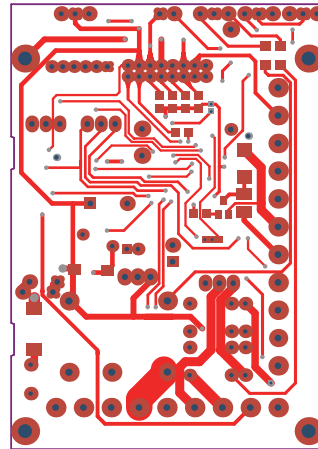
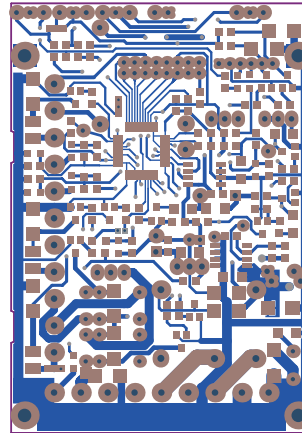

Figure 2 Block diagram

**THE PCB LAYOUTS – TOP & BOTTOM SIDES**



Top side circuit diagram



Bottom side circuit diagram

T18	INT. LOCK	Interlock control – N.O. input, connect to Output 1 Inhibit of second keypad if needed so that if one keypad is used to open door Output 1, the other is temporarily disabled.
T19	TAMPER	Tamper switch output – N.C. contact , max 50mA@24VDC, Connect to the N.C. 24 hour protection zone of an alarm if needed.
T20	TAMPER	

## THE DESCRIPTION

### Description of the Block Diagram – SK3133-PPQ

The key functions of the keypad are prepared with the software that programmed in the MCU. It provides the following functions.

- 1) A keyboard for code entry.
- 2) 125Khz Proximity Card detection.
- 3) 3 groups of user codes for controlling output 1, 2 & 3
- 4) Amber (Middle) LED driver for the "Main/Status".
- 5) Green/Red (Right) LED driver for Output 1 & Output 2.
- 6) Red (Left) LED driver for Inhibit.
- 7) The output port to give Keypad Active or Alarm function.
- 8) N.C. Tamper closed contact is allowed to connect.
- 9) A Normally Closed (N.C.) door sensing point with the help for monitors the open or close status of the door.
- 10) Inter-lock output which gives signal to disable the partner keypad in an inter-lock system.
- 11) Output 1 Inhibit Control Input which mainly for the cross wire connection with the "Inter-lock O/P" point of partner keypad in an inter-lock system.
- 12) Duress Output used for trigger an alarm zone of a security system or turn on a buzzer to notify a guard.
- 13) A buzzer driver to provide pacific tones.

### MCU - Fujitsu MB95F698K

- The operating voltage 5V
- Built-in low voltage detection reset circuit  
The low-voltage detection reset circuit generates a reset signal if the power supply voltage falls below the low-voltage detection voltage.
- CMOS I/O ports
- Lead-Free Packaging

### E2PROM – AT24C256

- It is a memory device stores all the programming data from MCU.
- Up to 1200 users (codes/cards) storage.

### 125 KHZ CARD RECEIVERS

- Referring figure 2 block diagram, MCU pin "125KHZ" continuously generate a 125 kHz square wave. The antenna module takes a 125 kHz square wave input, buffers it, using two inverting gates(U4A,U4B) and push pull amplifier(Q16~Q19), forming the carrier signal, and fed into an antenna that transmits the carrier continuously toward any RFID tag(ANT) position above it.
- The part of the filtering module's main purpose (U4C~U4F) is to filter out the carrier signal and any noise that was picked up by the antenna.
- The encoded signal is picked up by the reader's antenna, filtered, and processed on the embedded microcontroller(pin EM\_IN) to extract the tag's unique identity. At this point the identity can be matched against the records stored on the reader.
- It is compatible with ID cards of 64 bit read-only EM4100, TK4100, and EM4102 series. This module outputs original card information (Manchester code) and ascii codes. Code format: Manufacturers code + ID card number + parity bits.

## POWER SUPPLY

### SWITCHING POWER SUPPLY

- The XL1509 is a 150 KHz fixed frequency PWM buck (step-down) DC/DC converter, capable of driving a 2A load with high efficiency, low ripple and excellent line and load regulation.
- Referring to schematic diagram figure 1, input voltage range from DC12V to DC24V step down to DC9.5V , then output to RELAY unit and 78M05 regulator.

### 5V VOLTAGE REGULATOR

- 78M05 provide a stable voltage (DC5V) to MCU unit.

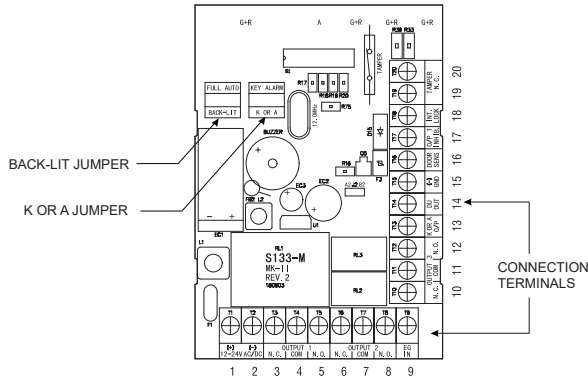

Connection Terminals		
Terminals No.	Terminal Name	Description
T10	Output 3 Relay N.C.	Output 3, N.C./COM/N.O. Max. 1A@24VDC
T11	Output 3 Relay COM	
T12	Output 3 Relay N.O.	
T13	K OR A O/P (selectable by Jumper)	K (Keypad Active Output) – NPN Transistor ground output , max 100mA@24VDC A (Alarm Output) – NPN Transistor ground output , max 100mA@24VDC
T14	DU OUT	Duress Output – NPN Transistor ground output, max. 100mA@24VDC. Triggers a silent alarm or other device when the user enters a duress code.
T15	GND	Common ground output
T16	DOOR SENS	Door Sensor – Connect to an optional N.C. sensor such as a magnetic contact to monitor if the door Output 1 is open or closed. Connect to ground if not used.
T17	O/P 1 INHIB.	Output 1 inhibit – N.O. input, connected to interlock control of second keypad if needed so that if one keypad is used to open a door Output 1 , the other is temporarily disabled.

Connection Terminals		
Terminals No.	Terminal Name	Description
T1	12-24V AC/DC	Connect to 12 – 24V AC/DC Power supply.
T2	GND	
T3	Output 1 N.C.	Output 1 , N.C./COM/N.O. Relay output, Max. 5A@24VDC
T4	Output 1 COM	
T5	Output 1 N.O.	
T6	Output 2 N.C.	Output 2 , Relay output, Max. 1A@24VDC
T7	Output 2 COM	
T8	Output 2 N.O.	
T9	EG IN	Egress In – N.O. Push button contact to ground, Press button to Initiate door unlock Output 1

## FCC STATEMENT

1. This device complies with Part 15 of the FCC Rules. Operation is subject to the following two conditions: (1) This device may not cause harmful interference, and (2) This device must accept any interference received, including interference that may cause undesired operation.
2. Changes or modifications not expressly approved by the party responsible for compliance could void the user's authority to operate the equipment.

This equipment has been tested and found to comply with the limits for a Class B digital device, pursuant to part 15 of the FCC Rules. These limits are designed to provide reasonable protection against harmful interference in a residential installation. This equipment generates, uses and can radiate radio frequency energy and, if not installed and used in accordance with the instructions, may cause harmful interference to radio communications. However, there is no guarantee that interference will not occur in a particular installation. If this equipment does cause harmful interference to radio or television reception, which can be determined by turning the equipment off and on, the user is encouraged to try to correct the interference by one or more of the following measures:

- Reorient or relocate the receiving antenna.
- Increase the separation between the equipment and receiver.
- Connect the equipment into an outlet on a circuit different from that to which the receiver is connected.
- Consult the dealer or an experienced radio/ TV technician for help.