

FCC REPORT

Applicant: Primos Inc

Address of Applicant: 604 First Street Flora Mississippi United States 39071

Equipment Under Test (EUT)

Product Name: Speak Easy

Model No.: 7754, 3758

FCC ID: K2R-5500

Applicable standards: FCC CFR Title 47 Part 15 Subpart C Section 15.231:2010

Date of sample receipt: Apr. 10, 2012

Date of Test: Apr. 10-May 02, 2012

Date of report issued: May 03, 2012

Test Result : PASS *

* In the configuration tested, the EUT complied with the standards specified above.

Authorized Signature:

A circular logo for GTS Global Testing is overlaid with a handwritten signature in blue ink. The logo contains the text 'GTS GLOBAL TESTING' and 'GLOBAL UNITED TECHNOLOGY SERVICES CO., LTD.' around the perimeter.

Robinson Lu
Laboratory Manager

This report details the results of the testing carried out on one sample. The results contained in this test report do not relate to other samples of the same product and does not permit the use of the GTS product certification mark. The manufacturer should ensure that all products in series production are in conformity with the product sample detailed in this report.

This report may only be reproduced and distributed in full. If the product in this report is used in any configuration other than that detailed in the report, the manufacturer must ensure the new system complies with all relevant standards. Any mention of GTS International Electrical Approvals or testing done by GTS International Electrical Approvals in connection with, distribution or use of the product described in this report must be approved by GTS International Electrical Approvals in writing.

This document cannot be reproduced except in full, without prior written approval of the Company. Any unauthorized alteration, forgery or falsification of the content or appearance of this document is unlawful and offenders may be prosecuted to the fullest extent of the law. Unless otherwise stated the results shown in this test report refer only to the sample(s) tested and such sample(s) are retained for 90 days only."

2 Version

Version No.	Date	Description
00	May 03, 2012	Original

Prepared By: Oscear. Li **Date:** May 03, 2012
Project Engineer

Check By: Hans. Hu **Date:** May 03, 2012
Reviewer

3 Contents

Page

1	COVER PAGE.....	1
2	VERSION.....	2
3	CONTENTS.....	3
4	TEST SUMMARY.....	4
5	GENERAL INFORMATION.....	5
5.1	CLIENT INFORMATION.....	5
5.2	GENERAL DESCRIPTION OF E.U.T.....	5
5.3	TEST MODE.....	6
5.4	TEST FACILITY.....	6
5.5	TEST LOCATION.....	6
5.6	OTHER INFORMATION REQUESTED BY THE CUSTOMER.....	6
5.7	TEST INSTRUMENTS LIST.....	7
6	TEST RESULTS AND MEASUREMENT DATA.....	8
6.1	ANTENNA REQUIREMENT:.....	8
6.2	RADIATED EMISSION METHOD.....	9
6.2.1	Field Strength of The Fundamental Signal.....	11
6.2.2	Spurious emissions.....	13
6.3	20dB OCCUPY BANDWIDTH.....	15
6.4	DWELL TIME:.....	16
7	TEST SETUP PHOTO.....	17
8	EUT CONSTRUCTIONAL DETAILS.....	18

4 Test Summary

Test Item	Section in CFR 47	Result
Antenna requirement	15.203	Pass
Field strength of the fundamental signal	15.231 (b)	Pass
Spurious emissions	15.231 (b)/15.209	Pass
20dB Bandwidth	15.231 (c)	Pass
Dwell time	15.231 (a)	Pass

Pass: The EUT complies with the essential requirements in the standard.

5 General Information

5.1 Client Information

Applicant:	Primos Inc
Address of Applicant:	604 First Street Flora Mississippi United States 39071
Manufacturer:	TAT MAN INVESTEMENT LIMITED
Address of Manufacturer	Room 910, 9/F, Hang Bong Commercial Centre, 28 ShangHai Street, TsimShaTsui, HK
Factory:	YaoBiao Manufactory
Address of Factory:	C Tower, YaoBiao Factory, AoDing Village, GuangDong Community GuanLan Street, BaoAn County, SZ City, GuangDong, China

5.2 General Description of E.U.T.

Product Name:	Speak Easy
Model No.:	7754, 3758
Operation Frequency:	315.48MHz
Modulation technology:	ASK
Antenna Type:	PCB antenna
Antenna gain:	2dBi (declare by Manufacturer)
Power supply:	DC 1.5V(1*1.5V for "AAA" Size)
Remark:	Only the model No. 7754 was tested. 3758 and 7754 are identical interior structure, electrical circuits, components and appearance with different model names for the marketing requirement.

5.3 Test mode

Transmitting mode	Keep the EUT in transmitting mode.
-------------------	------------------------------------

Per-test mode.

We have verified the construction and function in typical operation, The EUT was placed on three different polar directions; i.e. X axis, Y axis, Z axis. which was shown in this test report and defined as follows:

Axis	X	Y	Z
Field Strength(dBuV/m)	82.24	85.87	81.11

Final Test Mode:

According to ANSI C63.4 standards, the test results are both the “worst case” and “worst setup”:
Y axis (see the test setup photo)

5.4 Test Facility

The test facility is recognized, certified, or accredited by the following organizations:

- **FCC —Registration No.: 600491**

Global United Technology Services Co., Ltd., Shenzhen EMC Laboratory has been registered and fully described in a report filed with the (FCC) Federal Communications Commission.

The acceptance letter from the FCC is maintained in our files. Registration 600491, July 20, 2010.

- **Industry Canada (IC)**

The 3m Semi-anechoic chamber of Global United Technology Services Co., Ltd. Has been

Registered by Certification and Engineering Bureau of Industry Canada for radio equipment testing with Registration No.: 9079A-1.

5.5 Test Location

All tests were performed at:

Global United Technology Services Co., Ltd.

Address: 2nd Floor, Block No.2, Laodong Industrial Zone, Xixiang Road Baoan District, Shenzhen, China

Tel: 0755-27798480

Fax: 0755-27798960

5.6 Other Information Requested by the Customer

None.

5.7 Test Instruments list

Radiated Emission:						
Item	Test Equipment	Manufacturer	Model No.	Inventory No.	Cal.Date (mm-dd-yy)	Cal.Due date (mm-dd-yy)
1	3m Semi- Anechoic Chamber	ZhongYu Electron	9.2(L)*6.2(W)* 6.4(H)	GTS250	Mar. 30 2011	Mar. 29 2013
2	Control Room	ZhongYu Electron	6.2(L)*2.5(W)* 2.4(H)	GTS251	N/A	N/A
3	EMI Test Receiver	Rohde & Schwarz	ESU26	GTS203	Jul. 04 2011	Jul. 03 2012
4	BiConiLog Antenna	SCHWARZBECK MESS-ELEKTRONIK	VULB9163	GTS214	Mar. 10 2012	Mar. 09 2013
5	Double -ridged waveguide horn	SCHWARZBECK MESS-ELEKTRONIK	9120D-829	GTS208	Mar. 10 2012	Mar. 09 2013
6	Horn Antenna	ETS-LINDGREN	3160	GTS217	Mar. 10 2012	Mar. 09 2013
7	EMI Test Software	AUDIX	E3	N/A	N/A	N/A
8	Coaxial Cable	GTS	N/A	GTS213	Jul. 04 2011	Jul. 03 2012
9	Coaxial Cable	GTS	N/A	GTS211	Jul. 04 2011	Jul. 03 2012
10	Coaxial cable	GTS	N/A	GTS210	Jul. 04 2011	Jul. 03 2012
11	Coaxial Cable	GTS	N/A	GTS212	Jul. 04 2011	Jul. 03 2012
12	Amplifier(100kHz-3GHz)	HP	8347A	GTS204	Jul. 04 2011	Jul. 03 2012
13	Amplifier(2GHz-20GHz)	HP	8349B	GTS206	Jul. 04 2011	Jul. 03 2012
14	Amplifier (18-26GHz)	Rohde & Schwarz	AFS33-18002 650-30-8P-44	GTS218	June 30 2011	June 29 2012
15	Band filter	Amindeon	82346	GTS219	Mar. 31 2012	Mar. 30 2013
16	D.C. Power Supply	Instek	PS-3030	GTS232	Mar. 31 2012	Mar. 30 2013
17	Thermo meter	KTJ	TA328	GTS256	Jul. 07 2011	Jul. 06 2012

General used equipment:						
Item	Test Equipment	Manufacturer	Model No.	Inventory No.	Cal.Date (dd-mm-yy)	Cal.Due date (dd-mm-yy)
1	Barometer	ChangChun	DYM3	GTS257	July 11 2011	July 10 2012

6 Test results and Measurement Data

6.1 Antenna requirement:

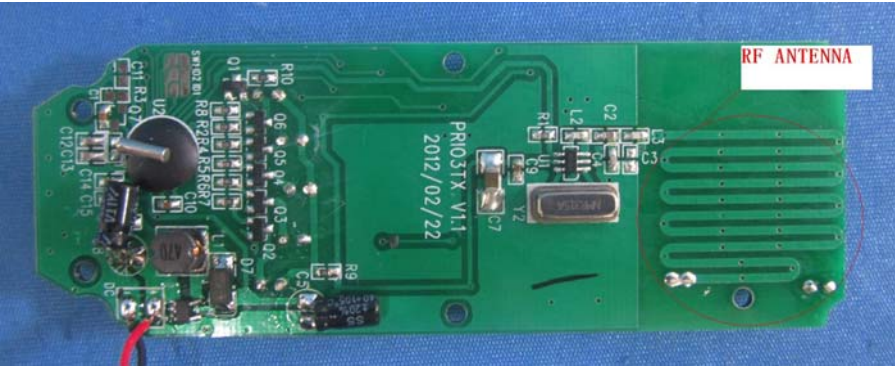
Standard requirement:	FCC Part15 C Section 15.203
<p>15.203 requirement:</p> <p>An intentional radiator shall be designed to ensure that no antenna other than that furnished by the responsible party shall be used with the device. The use of a permanently attached antenna or of an antenna that uses a unique coupling to the intentional radiator, the manufacturer may design the unit so that a broken antenna can be replaced by the user, but the use of a standard antenna jack or electrical connector is prohibited.</p>	
E.U.T Antenna:	
<p>The EUT make use of a PCB antenna, the typical gain of the antenna is 2dBi.</p> 	

6.2 Radiated Emission Method

Test Requirement:	FCC Part15 C Section 15.209			
Test Method:	ANSI C63.4: 2003			
Test Frequency Range:	30MHz to 3200MHz			
Test site:	Measurement Distance: 3m			
Receiver setup:	Frequency	Detector	RBW	VBW
	30MHz-1GHz	Quasi-peak	120KHz	300KHz
	Above 1GHz	Peak	1MHz	3MHz
Limit: (Field strength of the fundamental signal)	Frequency	Limit (dBuV/m @3m)		Remark
	315.48MHz	75.62		Average Value
		95.62		Peak Value
Limit: (Spurious Emissions)	Frequency	Limit (dBuV/m @3m)	Remark	
	30MHz-88MHz	40.00	Quasi-peak Value	
	88MHz-216MHz	43.50	Quasi-peak Value	
	216MHz-960MHz	46.00	Quasi-peak Value	
	960MHz-1GHz	54.00	Quasi-peak Value	
	Above 1GHz	54.00		Average Value
		74.00		Peak Value
Or The maximum permitted unwanted emission level is 20 dB below the maximum permitted fundamental level whichever limit permits a higher field strength.				
Test setup:	Below 1GHz			
Above 1GHz				

	<p>The diagram illustrates the test setup. An EUT (Equipment Under Test) is placed on a turn table that is 0.8 meters above the ground. The turn table is positioned 3 meters away from the antenna tower. The antenna tower is a variable-height structure with a horn antenna mounted on top. The antenna height is varied from 1 meter to 4 meters above the ground. The antenna is connected to a spectrum analyzer via an amplifier.</p>
<p>Test Procedure:</p>	<ol style="list-style-type: none"> 1. The EUT was placed on the top of a rotating table 0.8 meters above the ground at a 3 meter camber. The table was rotated 360 degrees to determine the position of the highest radiation. 2. The EUT was set 3 meters away from the interference-receiving antenna, which was mounted on the top of a variable-height antenna tower. 3. The antenna height is varied from one meter to four meters above the ground to determine the maximum value of the field strength. Both horizontal and vertical polarizations of the antenna are set to make the measurement. 4. For each suspected emission, the EUT was arranged to its worst case and then the antenna was tuned to heights from 1 meter to 4 meters and the rota table was turned from 0 degrees to 360 degrees to find the maximum reading. 5. The test-receiver system was set to Peak Detect Function and Specified Bandwidth with Maximum Hold Mode. 6. If the emission level of the EUT in peak mode was 10dB lower than the limit specified, then testing could be stopped and the peak values of the EUT would be reported. Otherwise the emissions that did not have 10dB margin would be re-tested one by one using peak, quasi-peak or average method as specified and then reported in a data sheet.
<p>Test Instruments:</p>	<p>Refer to section 5.7 for details</p>
<p>Test mode:</p>	<p>Refer to section 5.3 for details</p>
<p>Test results:</p>	<p>Pass</p>

Measurement data:

6.2.1 Field Strength of The Fundamental Signal

Peak value:

Frequency (MHz)	Read Level (dBuV)	Antenna Factor (dB/m)	Cable Loss (dB)	Preamp Factor (dB)	Level (dBuV/m)	Limit Line (dBuV/m)	Over Limit (dB)	polarization
315.48	104.25	13.28	0.64	32.3	85.87	95.62	-9.75	Horizontal
315.48	95.67	12.73	0.64	32.3	76.74	95.62	-18.88	Vertical

Average value:

Frequency (MHz)	Peak Value (dBuV/m)	Duty cycle factor	Average value (dBuV/m)	Limit Line (dBuV/m)	Over Limit (dB)	Polarization
315.48	85.87	-14.33	71.54	75.62	-4.08	Horizontal
315.48	76.74	-14.33	62.41	75.62	-13.21	Vertical

Average value:	
Calculate Formula:	Average value=Peak value + Duty Cycle Factor
	Duty cycle factor=20 log(Duty cycle)
	Duty cycle= T on time / T period
Test data:	Ton time =(8.94-3.92)*1+(13.68-11.88)*2+0.609*11=15.31ms
	T period =79.69ms
	Duty cycle= 19.21%
	duty cycle factor= -14.33

Test plot as follows:

T period:

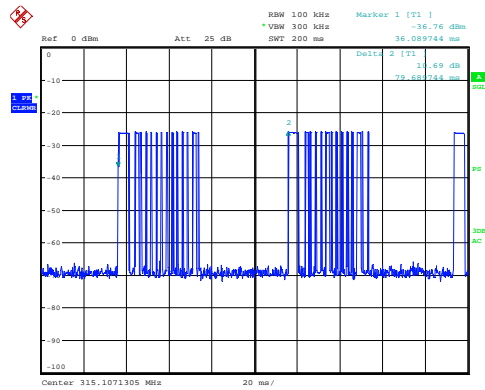

Date: 16.APR.2012 11:05:00

T on time slot:

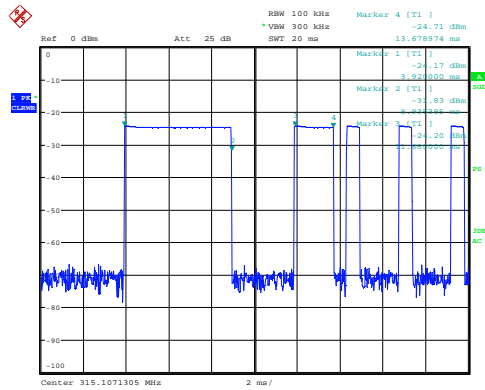

Date: 16.APR.2012 11:09:53

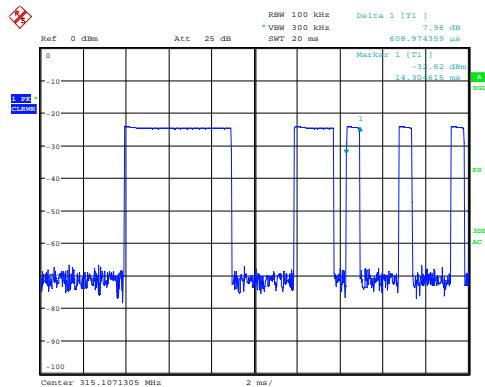

Date: 16.APR.2012 11:10:39

6.2.2 Spurious emissions

■ Below 1GHz

Frequency (MHz)	Read Level (dBuV)	Antenna Factor (dB/m)	Cable Loss (dB)	Preamp Factor (dB)	Level (dBuV/m)	Limit Line (dBuV/m)	Over Limit (dB)	polarization
56.79	41.51	14.70	0.18	31.97	24.42	40.00	-15.58	Vertical
96.10	39.62	12.13	0.22	31.71	20.26	43.50	-23.24	Vertical
143.83	40.08	12.86	0.31	31.95	21.30	43.50	-22.20	Vertical
354.18	46.66	12.97	0.73	32.31	28.05	46.00	-17.95	Vertical
630.96	61.39	19.06	1.23	31.43	50.25	55.62	-5.37	Vertical
946.44	56.78	23.58	1.78	31.49	50.65	55.62	-4.97	Vertical
58.41	42.62	12.96	0.18	31.97	23.79	40.00	-16.21	Horizontal
94.43	38.96	11.81	0.22	31.73	19.26	43.50	-24.24	Horizontal
130.38	37.75	13.43	0.31	31.86	19.63	43.50	-23.87	Horizontal
207.85	53.81	10.63	0.46	32.27	32.63	43.50	-10.87	Horizontal
630.96	64.04	19.06	1.23	31.43	52.90	55.62	-2.72	Horizontal
946.44	58.51	23.58	1.78	31.49	52.38	55.62	-3.24	Horizontal

■ Above 1GHz

Peak value:

Frequency (MHz)	Read Level (dBuV)	Antenna Factor (dB/m)	Cable Loss (dB)	Preamp Factor (dB)	Level (dBuV/m)	Limit Line (dBuV/m)	Over Limit (dB)	polarization
1260.43	53.71	25.55	2.07	31.68	49.65	75.62	-25.97	Vertical
1575.54	65.82	25.02	2.28	31.82	61.30	75.62	-14.32	Vertical
2205.76	59.83	27.96	2.70	31.44	59.05	74.00	-14.95	Vertical
2835.97	56.22	28.39	3.13	29.92	57.82	74.00	-16.18	Vertical
3037.72	*							Vertical
1260.43	54.28	25.55	2.07	31.68	50.22	75.62	-25.40	Horizontal
1575.54	60.65	25.02	2.28	31.82	56.13	75.62	-19.49	Horizontal
2205.76	62.24	27.96	2.70	31.44	61.46	74.00	-12.54	Horizontal
2835.97	56.26	28.39	3.13	29.92	57.86	74.00	-16.14	Horizontal
3037.72	*							Horizontal

Average value:

Frequency (MHz)	Level (dBuV/m)	Duty cycle factor	Average value (dBuV/m)	Limit Line (dBuV/m)	Over Limit (dB)	polarization
1260.43	50.22	-14.33	35.89	55.62	-19.73	Horizontal
1575.54	56.13	-14.33	41.80	55.62	-13.82	Horizontal
2205.76	61.46	-14.33	47.13	54.00	-6.87	Horizontal
2835.97	57.86	-14.33	43.53	54.00	-10.47	Horizontal
3037.72	*					Horizontal
1260.43	49.65	-14.33	35.32	55.62	-20.30	Vertical
1575.54	61.30	-14.33	46.97	55.62	-8.65	Vertical
2205.76	59.05	-14.33	44.72	54.00	-9.28	Vertical
2835.97	57.82	-14.33	43.49	54.00	-10.51	Vertical
3037.72	*					Vertical

Remark:

1. *Final Level = Receiver Read level + Antenna Factor + Cable Loss – Pre-amplifier Factor*
2. *Average value = Peak value + Duty cycle factor*
3. *“*” , means this data is the too weak instrument of signal is unable to test.*

6.3 20dB Occupy Bandwidth

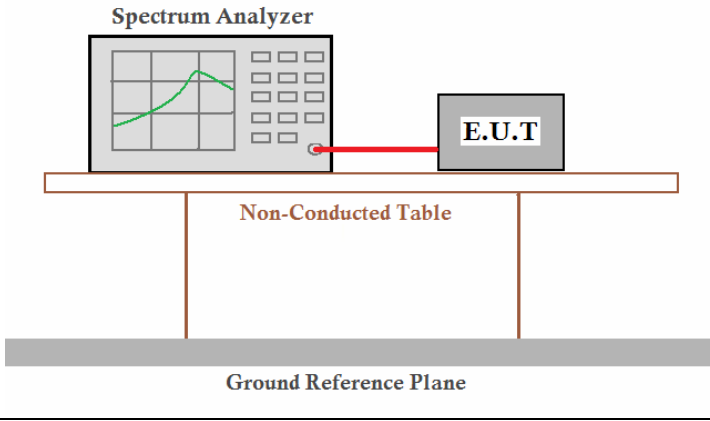
Test Requirement:	FCC Part15 C Section 15.231 (c)
Test Method:	ANSI C63.4:2003
Limit:	The bandwidth of the emission shall be no wider than 0.25% of the center frequency for devices operating above 70 MHz and below 900 MHz. For devices operating above 900 MHz, the emission shall be no wider than 0.5% of the center frequency. Bandwidth is determined at the points 20 dB down from the modulated carrier.
Test setup:	
Test Instruments:	Refer to section 5.7 for details
Test mode:	Refer to section 5.3 for details
Test results:	Pass

Measurement Data

Test Frequency (MHz)	20dB bandwidth (MHz)	Limit (MHz)	Result
315.48	0.05	0.789 MHz	Pass

Note: Limit= Fundamental frequency×0.25%=315.48×0.25%=0.789MHz

Test plot as follows:

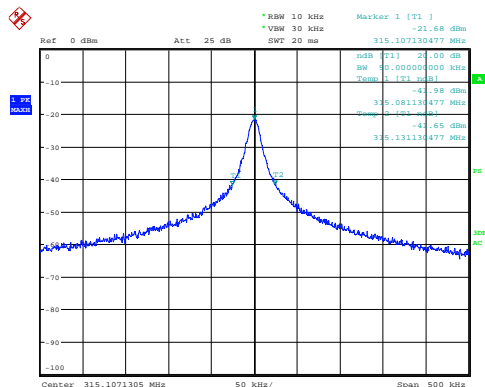

Date: 16.APR.2012 11:01:31

6.4 Dwell time:

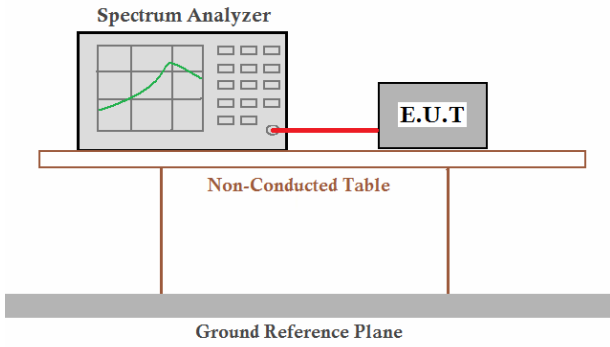
Test Requirement:	FCC Part15 C Section 15.231 (e)
Test Method:	ANSI C63.4:2003
Receiver setup:	RBW=100KHz, VBW=300KHz, span=0Hz, detector: Peak
Limit:	Not more than 5 seconds
Test setup:	
Test Instruments:	Refer to section 5.7 for details
Test mode:	Refer to section 5.3 for details
Test results:	Pass

Measurement data:

Dwell time (second)	Limit (second)	Result
1.21	<5.0	Pass

Test plot as follows:

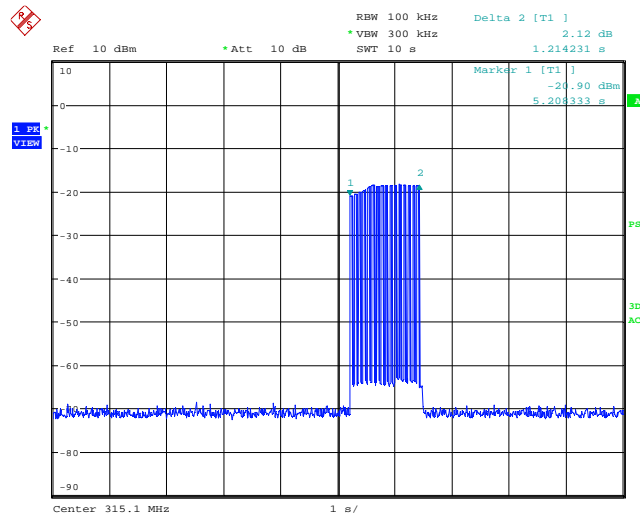

Date: 17.APR.2012 18:34:56

7 Test Setup Photo

Radiated Emission

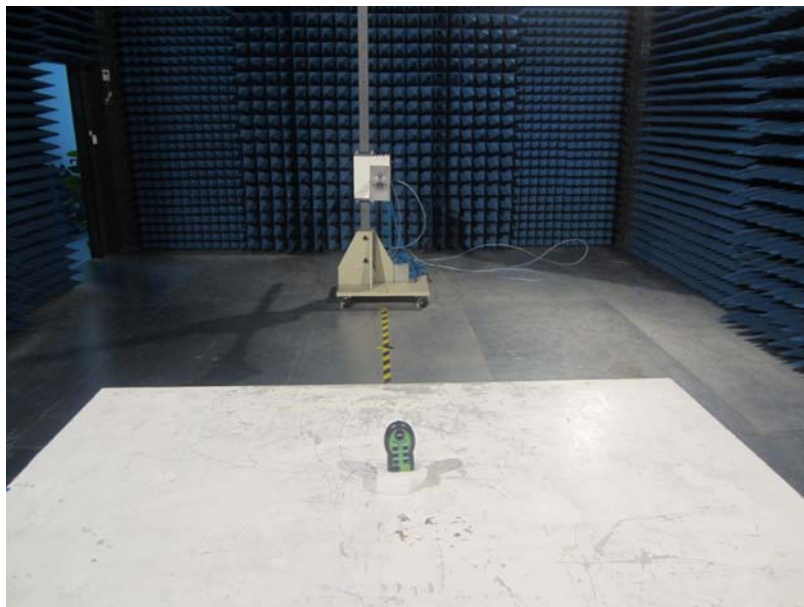
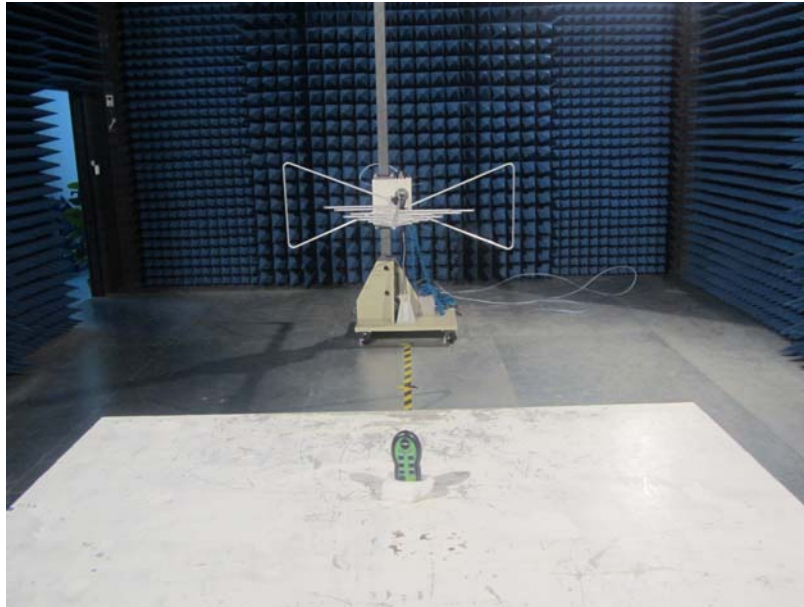

8 EUT Constructional Details







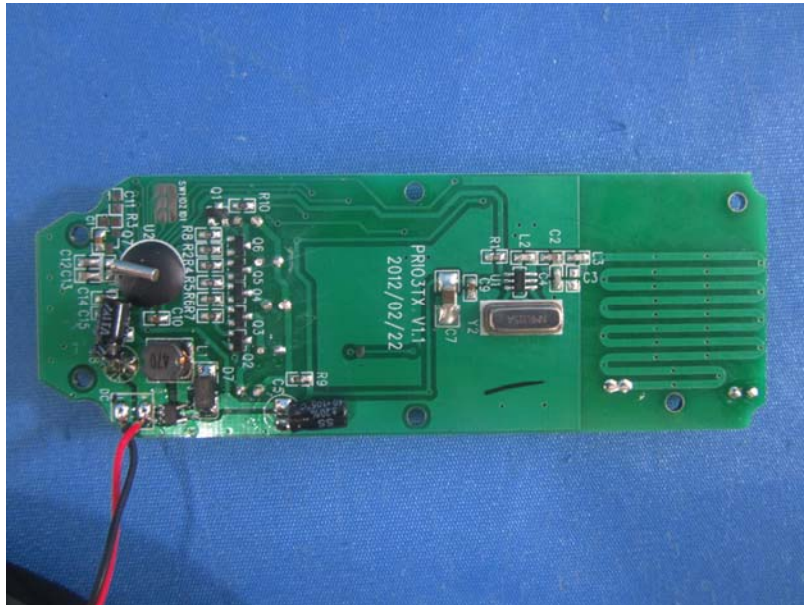
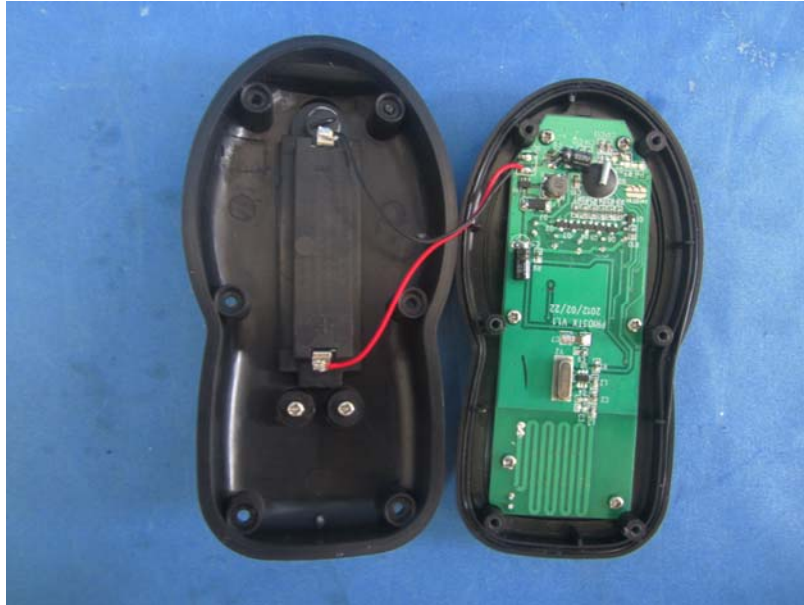

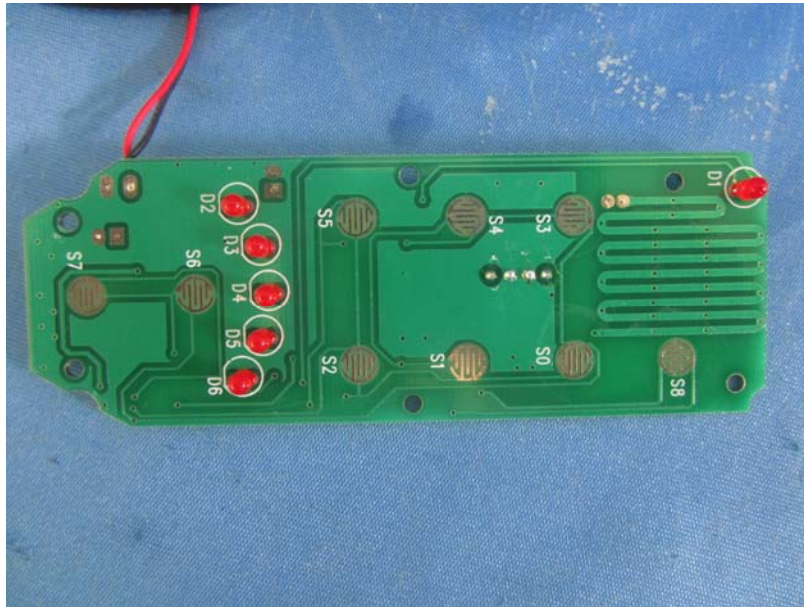

----- End -----