



FCC Test Report

APPLICANT : Motorola Mobility LLC
EQUIPMENT : Mobile Cellular Phone
BRAND NAME : Motorola
MODEL NAME : XT1926-2, XT1926-3
FCC ID : IHDT56WL2
STANDARD : FCC 47 CFR FCC Part 15 Subpart B
CLASSIFICATION : Certification

The product was received on Dec. 27, 2017 and testing was completed on Jan. 26, 2018. We, Sporton International (KunShan) Inc., would like to declare that the tested sample has been evaluated in accordance with the test procedures given in ANSI C63.4-2014 and has been in compliance with the applicable technical standards.

The test results in this report apply exclusively to the tested model / sample. Without written approval of Sporton International (KunShan) Inc., the test report shall not be reproduced except in full.



Approved by: James Huang / Manager

Sporton International (Kunshan) Inc.

No.3-2 Ping-Xiang Rd, Kunshan Development Zone Kunshan City Jiangsu Province 215335 China



TABLE OF CONTENTS

REVISION HISTORY..... 3

SUMMARY OF TEST RESULT 4

1. GENERAL DESCRIPTION 5

 1.1. Applicant..... 5

 1.2. Manufacturer 5

 1.3. Product Feature of Equipment Under Test 5

 1.4. Product Specification of Equipment Under Test 6

 1.5. Modification of EUT 7

 1.6. Specification of Accessory 8

 1.7. Test Location 9

 1.8. Applicable Standards 9

2. TEST CONFIGURATION OF EQUIPMENT UNDER TEST 10

 2.1. Test Mode 10

 2.2. Connection Diagram of Test System 12

 2.3. Support Unit used in test configuration and system 14

 2.4. EUT Operation Test Setup 15

3. TEST RESULT 16

 3.1. Test of AC Conducted Emission Measurement 16

 3.2. Test of Radiated Emission Measurement 24

4. LIST OF MEASURING EQUIPMENT 30

5. UNCERTAINTY OF EVALUATION 31

APPENDIX A. SETUP PHOTOGRAPHS



REVISION HISTORY

REPORT NO.	VERSION	DESCRIPTION	ISSUED DATE
FC7D2702-01	Rev. 01	Initial issue of report	Mar. 13, 2018



SUMMARY OF TEST RESULT

Report Section	FCC Rule	Description	Limit	Result	Remark
3.1	15.107	AC Conducted Emission	< 15.107 limits	PASS	Under limit 4.08 dB at 0.267 MHz
3.2	15.109	Radiated Emission	< 15.109 limits	PASS	Under limit 4.35 dB at 44.580 MHz for Quasi-Peak



1. General Description

1.1. Applicant

Motorola Mobility LLC
222 W,Merchandise Mart Plaza, Chicago IL 60654 USA

1.2. Manufacturer

Motorola Mobility LLC
222 W,Merchandise Mart Plaza, Chicago IL 60654 USA

1.3. Product Feature of Equipment Under Test

Product Feature	
Equipment	Mobile Cellular Phone
Brand Name	Motorola
Model Name	XT1926-2, XT1926-3
FCC ID	IHDT56WL2
EUT supports Radios application	GSM/GPRS/EGPRS/WCDMA/HSPA/DC-HSDPA/ HSPA+/LTE/NFC WLAN 2.4GHz 802.11b/g/n HT20 WLAN 5GHz 802.11a/n HT20/HT40 WLAN 5GHz 802.11ac VHT20/VHT40/VHT80 Bluetooth v3.0+ EDR / Bluetooth v4.0 LE/ Bluetooth v4.1 LE / Bluetooth v4.2 LE / Bluetooth v5.0 LE
IMEI Code	Conduction: 351854090024592/351854090024600 for Sample 1 351871090006163 for Sample 2 Radiation: 351854090024592 351854090024600 for Sample 1 351871090006197 for Sample 2
HW Version	DVT1B
SW Version	evert_n-userdebug 8.0.0 OPW27.88 1825 intcfg,test-keys
EUT Stage	Identical Prototype

Remark:

1. The above EUT's information was declared by manufacturer. Please refer to the specifications or user's manual for more detailed description.
2. There are two types of EUT sample 1 and sample 2, the differences between two samples are only for SIM slot, sample 1(Model name: XT1926-3) is dual SIM slot, sample 2(Model name: XT1926-2) is single SIM slot. According to the difference, we choose sample 1 to perform full test, and sample 2 to verify worst case.



1.4. Product Specification of Equipment Under Test

Standards-related Product Specification	
Tx Frequency	GSM850: 824.2 MHz ~ 848.8 MHz GSM1900: 1850.2 MHz ~ 1909.8MHz WCDMA Band V: 826.4 MHz ~ 846.6 MHz WCDMA Band II: 1852.4 MHz ~ 1907.6 MHz LTE Band 5 : 824.7 MHz ~ 848.3 MHz LTE Band 7 : 2502.5 MHz ~ 2567.5 MHz LTE Band 38 : 2572.5 MHz ~ 2617.5 MHz 802.11b/g/n: 2412 MHz ~ 2462 MHz 802.11a/n/ac: 5180 MHz ~ 5240 MHz; 5260 MHz ~ 5320 MHz; 5500 MHz ~ 5700 MHz; 5745 MHz ~ 5825 MHz; Bluetooth: 2402 MHz ~ 2480 MHz NFC : 13.56 MHz
Rx Frequency	GSM850: 869.2 MHz ~ 893.8 MHz GSM1900: 1930.2 MHz ~ 1989.8 MHz WCDMA Band V: 871.4 MHz ~ 891.6 MHz WCDMA Band II: 1932.4 MHz ~ 1987.6 MHz LTE Band 5 : 869.7 MHz ~ 893.3 MHz LTE Band 7 : 2622.5 MHz ~ 2687.5 MHz LTE Band 38 : 2572.5 MHz ~ 2617.5 MHz 802.11b/g/n: 2412 MHz ~ 2462 MHz 802.11a/n/ac: 5180 MHz ~ 5240 MHz; 5260 MHz ~ 5320 MHz; 5500 MHz ~ 5700 MHz; 5745 MHz ~ 5825 MHz; Bluetooth: 2402 MHz ~ 2480 MHz GNSS : 1559 MHz ~ 1610 MHz FM : 88 MHz ~ 108 MHz NFC : 13.56 MHz
Antenna Type	WWAN : PIFA Antenna WLAN : PIFA Antenna Bluetooth : PIFA Antenna GNSS: PIFA Antenna NFC: Loop Antenna FM: External headset Antenna



Type of Modulation	GSM: GMSK GPRS: GMSK EDGE(MCS 0-4): GMSK / (MCS 5-9): 8PSK WCDMA : BPSK (Uplink) HSDPA/DC-HSDPA : QPSK (Uplink) HSUPA : QPSK (Uplink) HSPA+ : 16QAM (Uplink) DC-HSDPA : 64QAM LTE: QPSK / 16QAM / 64QAM 802.11b : DSSS (DBPSK / DQPSK / CCK) 802.11a/g/n/ac : OFDM (BPSK / QPSK / 16QAM / 64QAM / 256QAM) Bluetooth LE : GFSK Bluetooth (1Mbps) : GFSK Bluetooth (2Mbps) : $\pi/4$ -DQPSK Bluetooth (3Mbps) : 8-DPSK GNSS : BPSK NFC : ASK FM
---------------------------	--

Note: GNSS Rx = GPS Rx + Glonass Rx

1.5. Modification of EUT

No modifications are made to the EUT during all test items.



1.6. Specification of Accessory

Specification of Accessory				
AC Adapter 1(US)	Brand Name	Motorola (Salom)	Model Name	SC-22
	Power Rating	I/P: 100-240 Vac, 500mA, O/P: 5Vdc,3000mA or 9Vdc,1600mA or 12Vdc,1200mA		
AC Adapter 1(EU)	Brand Name	Motorola (Salom)	Model Name	SC-23
	Power Rating	I/P: 100-240 Vac, 500mA, O/P: 5Vdc,3000mA or 9Vdc,1600mA or 12Vdc,1200mA		
AC Adapter 1(UK)	Brand Name	Motorola (Salom)	Model Name	SC-24
	Power Rating	I/P: 100-240 Vac, 500mA, O/P: 5Vdc,3000mA or 9Vdc,1600mA or 12Vdc,1200mA		
AC Adapter 1(IN)	Brand Name	Motorola (Salom)	Model Name	SC-25
	Power Rating	I/P: 100-240 Vac, 500mA, O/P: 5Vdc,3000mA or 9Vdc,1600mA or 12Vdc,1200mA		
AC Adapter 1(AU)	Brand Name	Motorola (Salom)	Model Name	SC-26
	Power Rating	I/P: 100-240 Vac, 500mA, O/P: 5Vdc,3000mA or 9Vdc,1600mA or 12Vdc,1200mA		
AC Adapter 2(US)	Brand Name	Motorola (Chenyang)	Model Name	SC-22
	Power Rating	I/P: 100-240 Vac, 500mA, O/P: 5Vdc,3000mA or 9Vdc,1600mA or 12Vdc,1200mA		
AC Adapter 2(EU)	Brand Name	Motorola (Chenyang)	Model Name	SC-23
	Power Rating	I/P: 100-240 Vac, 500mA, O/P: 5Vdc,3000mA or 9Vdc,1600mA or 12Vdc,1200mA		
AC Adapter 2(UK)	Brand Name	Motorola (Chenyang)	Model Name	SC-24
	Power Rating	I/P: 100-240 Vac, 500mA, O/P: 5Vdc,3000mA or 9Vdc,1600mA or 12Vdc,1200mA		
AC Adapter 2(IN)	Brand Name	Motorola (Chenyang)	Model Name	SC-25
	Power Rating	I/P: 100-240 Vac, 500mA, O/P: 5Vdc,3000mA or 9Vdc,1600mA or 12Vdc,1200mA		
AC Adapter 2(AU)	Brand Name	Motorola (Chenyang)	Model Name	SC-26
	Power Rating	I/P: 100-240 Vac, 500mA, O/P: 5Vdc,3000mA or 9Vdc,1600mA or 12Vdc,1200mA		
Battery	Brand Name	Motorola (ATL)	Model Name	JT40
	Power Rating	3.8Vdc,3200mAh	Type	Li-ion Polymer
Earphone 1	Brand Name	Motorola (Jiahe)	Model Name	LS-118M-12
	Signal Line Type	1.2 meter, non-shielded cable, without ferrite core		
Earphone 2	Brand Name	Motorola (Lianyun)	Model Name	TS910A-38AMS01WHR-M
	Signal Line Type	1.2 meter, non-shielded cable, without ferrite core		
USB Cable	Brand Name	Motorola (Liqi)	Model Name	L32B-053000100-ALL
	Signal Line Type	1.0 meter, shielded cable, without ferrite core		



1.7. Test Location

Sporton International (Kunshan) Inc. is accredited to ISO 17025 by National Voluntary Laboratory Accreditation Program (NVLAP code: 600155-0) and the FCC designation No. is CN5013.

Test Site	Sporton International (Kunshan) Inc.		
Test Site Location	No.3-2 Ping-Xiang Rd, Kunshan Development Zone Kunshan City Jiangsu Province 215335 China TEL : +86-512-57900158 FAX : +86-512-57900958		
Test Site No.	Sporton Site No.		FCC Test Firm Registration No.
	CO01-KS	03CH02-KS	630927

Note: The test site complies with ANSI C63.4 2014 requirement.

1.8. Applicable Standards

According to the specifications of the manufacturer, the EUT must comply with the requirements of the following standards:

- FCC 47 CFR FCC Part 15 Subpart B
- ANSI C63.4-2014

Remark: All test items were verified and recorded according to the standards and without any deviation during the test.



2. Test Configuration of Equipment Under Test

2.1. Test Mode

The EUT has been associated with peripherals pursuant to ANSI C63.4-2014 and configuration operated in a manner tended to maximize its emission characteristics in a typical application.

Frequency range investigated: conduction (150 kHz to 30 MHz), radiation (30MHz to the 5th harmonic of the highest fundamental frequency or to 40 GHz, whichever is lower).

Test Items	Function Type
AC Conducted Emission	Mode 1 : GSM 850 Idle + Bluetooth Idle + WLAN Idle (2.4G) + USB Cable (Charging from Adapter1) + Earphone 1 + Battery + Camera (Rear) + SIM 1 for Sample 1<fig.1>
	Mode 2 : PCS 1900 Idle + Bluetooth Idle + WLAN Idle (2.4G) + USB Cable (Charging from Adapter1) + Earphone 1 + Battery + Camera (Front) + SIM 2 for Sample 1<fig.1>
	Mode 3 : WCDMA Band V Idle + Bluetooth Idle + WLAN Idle (2.4G) + USB Cable (Charging from Adapter1) + Earphone 1 + Battery + MPEG4 + SIM 1 for Sample 1<fig.1>
	Mode 4 : WCDMA Band II Idle + Bluetooth Idle + WLAN Idle (2.4G) + USB Cable (Charging from Adapter1) + Earphone 1 + Battery + GNSS Rx + SIM 2 for Sample 1<fig.2>
	Mode 5 : WCDMA Band II Idle + Bluetooth Idle + WLAN Idle (2.4G) + USB Cable (Charging from Adapter1) + Earphone 1 + Battery + NFC On + SIM 2 for Sample 1<fig.1>
	Mode 6 : GSM 850 Idle + Bluetooth Idle + WLAN Idle (2.4G) + USB Cable (Charging from Adapter2) + Earphone 2 + Battery + Camera (Rear) + SIM 1 for Sample 1<fig.1>
	Mode 7 : GSM 850 Idle + Bluetooth Idle + WLAN Idle (2.4G) + USB Cable 1 (Charging from Adapter1) + Earphone 1 + Battery + Camera (Rear) for Sample 2<fig.1>
	Mode 8 : LTE Band 7 Idle + Bluetooth Idle + WLAN Idle (2.4G) + USB Cable (Data Link with Notebook) + Earphone 1 + Battery + GNSS Rx + SIM 1 for Sample 1<fig.3>
	Mode 9 : USB Cable (Charging from Adapter 1) + Earphone 1 + Battery + FM Rx (88MHz) for Sample 1<fig.4>
	Mode 10 : USB Cable (Charging from Adapter 1) + Earphone 1 + Battery + FM Rx (98MHz) for Sample 1<fig.4>
	Mode 11 : USB Cable (Charging from Adapter 1) + Earphone 1 + Battery + FM Rx (108MHz) for Sample 1<fig.4>
	Mode 12 : USB Cable (Charging from Adapter 2) + Earphone 2 + Battery + FM Rx (88MHz) for Sample 1<fig.4>



Radiated Emissions< 1GHz	<p>Mode 1: GSM 850 Idle + Bluetooth Idle + WLAN Idle (2.4G) + USB Cable (Charging from Adapter1) + Earphone 1 + Battery + Camera (Rear) + SIM 1 for Sample 1<fig.1></p> <p>Mode 2: PCS 1900 Idle + Bluetooth Idle + WLAN Idle (2.4G) + USB Cable (Charging from Adapter1) + Earphone 1 + Battery + Camera (Front) + SIM 2 for Sample 1<fig.1></p> <p>Mode 3: WCDMA Band V Idle + Bluetooth Idle + WLAN Idle (2.4G) + USB Cable (Charging from Adapter1) + Earphone 1 + Battery + MPEG4 + SIM 1 for Sample 1<fig.1></p> <p>Mode 4: WCDMA Band II Idle + Bluetooth Idle + WLAN Idle (2.4G) + USB Cable (Charging from Adapter1) + Earphone 1 + Battery + GNSS Rx + SIM 2 for Sample 1<fig.2></p> <p>Mode 5: WCDMA Band II Idle + Bluetooth Idle + WLAN Idle (2.4G) + USB Cable (Charging from Adapter1) + Earphone 1 + Battery + NFC On + SIM 2 for Sample 1<fig.1></p> <p>Mode 6: WCDMA Band V Idle + Bluetooth Idle + WLAN Idle (2.4G) + USB Cable (Charging from Adapter2) + Earphone 2 + Battery + MPEG4 + SIM 1 for Sample 1<fig.1></p> <p>Mode 7: GSM 850 Idle + Bluetooth Idle + WLAN Idle (2.4G) + USB Cable 1 (Charging from Adapter1) + Earphone 1 + Battery + MPEG4 for Sample 2<fig.1></p> <p>Mode 8: LTE Band 7 Idle + Bluetooth Idle + WLAN Idle (2.4G) + USB Cable (Data Link with Notebook) + Earphone 1 + Battery + GNSS Rx + SIM 1 for Sample 1<fig.3></p> <p>Mode 9: USB Cable (Charging from Adapter 1) + Earphone 1 + Battery + FM Rx (88MHz) for Sample 1<fig.4></p> <p>Mode 10 : USB Cable (Charging from Adapter 1) + Earphone 1 + Battery + FM Rx (98MHz) for Sample 1<fig.4></p> <p>Mode 11 : USB Cable (Charging from Adapter 1) + Earphone 1 + Battery + FM Rx (108MHz) for Sample 1<fig.4></p> <p>Mode 12 : USB Cable (Charging from Adapter 2) + Earphone 2 + Battery + FM Rx (108MHz) for Sample 1<fig.4></p>
Radiated Emissions ≥ 1GHz	<p>Mode 1: USB Cable (Charging from Adapter 1) + Earphone 1 + Battery + FM Rx (108MHz) for Sample 1 <Fig.4></p> <p>Mode 2: LTE Band 7 Idle + Bluetooth Idle + WLAN Idle (2.4G) + USB Cable (Data Link with Notebook) + Earphone 1 + Battery + GNSS Rx + SIM 1 for Sample 1<Fig.3></p>
<p>Remark:</p> <ol style="list-style-type: none"> 1. The worst case of AC is mode 12; and USB Link is mode 8, the test data of these modes were reported. 2. The worst case of RE < 1G is mode 11; and USB Link is mode 8, the test data of these modes were reported. 3. Data Link with Notebook means data application transferred mode between EUT and Notebook 	

2.2. Connection Diagram of Test System

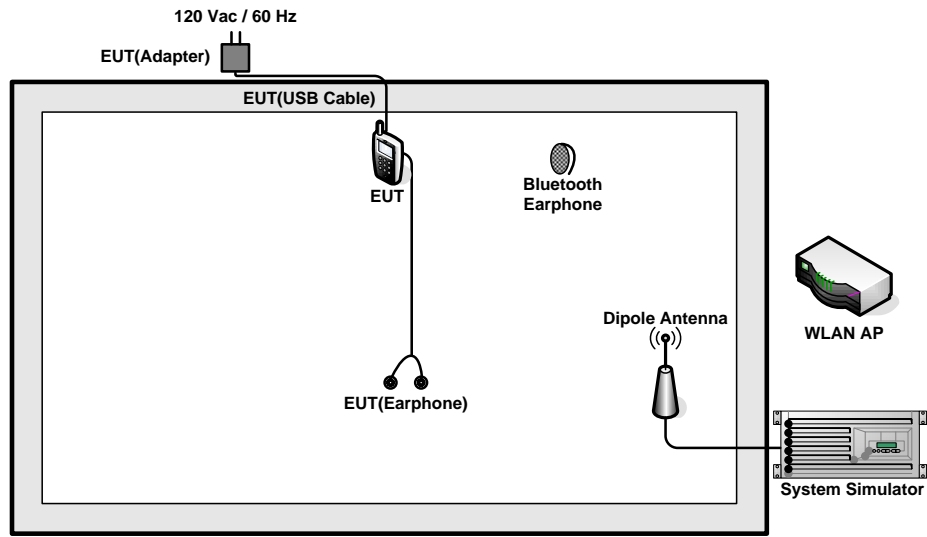

<Fig.1>

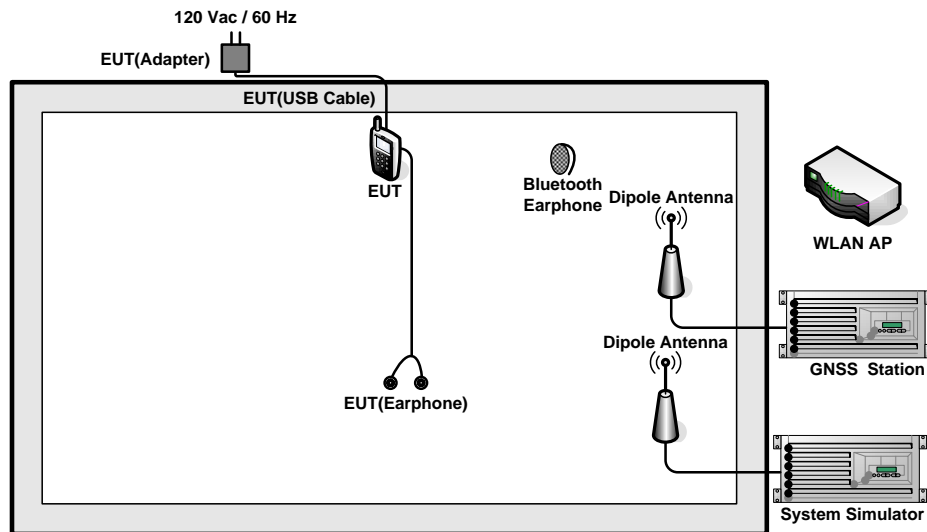

<Fig.2>

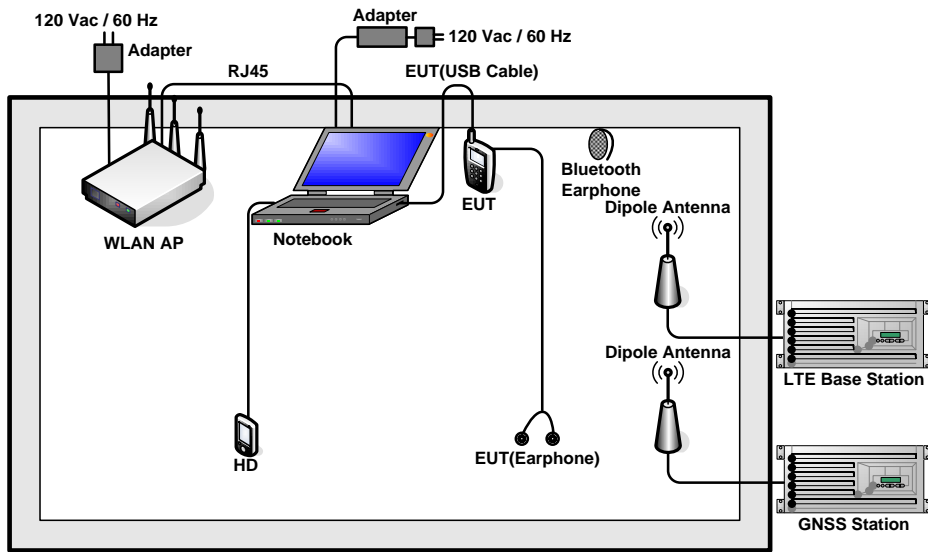

<Fig.3>

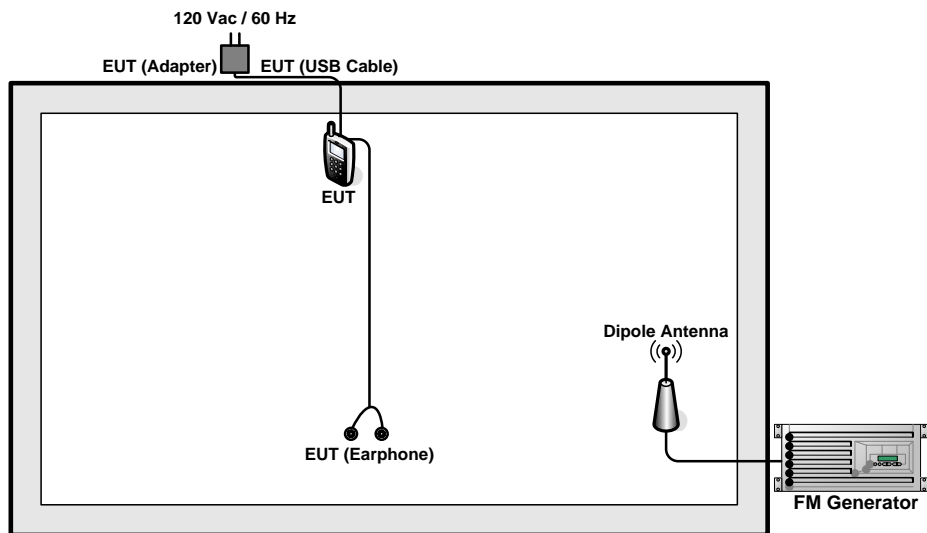

<Fig.4>



2.3. Support Unit used in test configuration and system

Item	Equipment	Trade Name	Model Name	FCC ID	Data Cable	Power Cord
1.	LTE Base Station	Anritsu	MT8820C	N/A	N/A	Unshielded,1.8m
2.	System Simulator	R&S	CMU200	N/A	N/A	Unshielded,1.8m
3.	GNSS Station	ADIVIC	MP9000	N/A	N/A	Unshielded,1.8m
4.	GNSS Station	RACELOGIC	RLLS03-2RP	N/A	N/A	Unshielded,1.8m
5.	FM Generator	R&S	SMBV100A	N/A	N/A	Unshielded, 1.8m
6.	WLAN AP	D-Link	DIR-855	KA2DIR855A2	N/A	Unshielded,1.8m
7.	WLAN AP	TP-LINK	TL-WDR5600	N/A	N/A	Unshielded, 1.8m
8.	Notebook	Lenovo	G480	N/A	N/A	AC I/P: Unshielded, 1.8m DC O/P: Shielded, 1.8m
9.	Notebook	Lenovo	Y510P	N/A	N/A	shielded cable DC O/P 1.8m , Unshielded AC I/P cable 1.8m
10.	Bluetooth Earphone	Lenovo	LBH308	N/A	N/A	N/A
11.	SD Card	Kingston	8GB	N/A	N/A	N/A
12.	SD Card	SanDisk	Uitra	N/A	N/A	N/A
13.	Hard Disk	Lenovo	F310	DoC	Shielded, 1.2m	N/A



2.4. EUT Operation Test Setup

The EUT was in GSM or WCDMA or LTE idle mode during the testing. The EUT was synchronized to the BCCH, and is in continuous receiving mode by setting system simulator's paging reorganization.

At the same time, the EUT was attached to the Bluetooth earphone or WLAN AP, and the following programs installed in the EUT were programmed during the test.

1. Data application is transferred between Notebook and EUT via USB cable.
2. Turn on GNSS function to make the EUT receive continuous signals from GNSS station.
3. Turn on FM function to make the EUT receive continuous signals from FM Generator
4. Execute "Video player" to play MPEG4 files.
5. Turn on camera to capture images.
6. Turn on NFC function.

3. Test Result

3.1. Test of AC Conducted Emission Measurement

3.1.1 Limits of AC Conducted Emission

For equipment that is designed to be connected to the public utility (AC) power line, the radio frequency voltage that is conducted back onto the AC power line on any frequency or frequencies within the band 150 kHz to 30 MHz shall not exceed the limits in the following table.

Frequency of emission (MHz)	Conducted limit (dBuV)	
	Quasi-peak	Average
0.15-0.5	66 to 56*	56 to 46*
0.5-5	56	46
5-30	60	50

*Decreases with the logarithm of the frequency.

3.1.2 Measuring Instruments

The measuring equipment is listed in the section 4 of this test report.

3.1.3 Test Procedure

1. The EUT was placed 0.4 meter from the conducting wall of the shielding room was kept at least 80 centimeters from any other grounded conducting surface.
2. Connect EUT to the power mains through a line impedance stabilization network (LISN).
3. All the support units are connecting to the other LISN.
4. The LISN provides 50 ohm coupling impedance for the measuring instrument.
5. The FCC states that a 50 ohm, 50 microhenry LISN should be used.
6. Both sides of AC line were checked for maximum conducted interference.
7. The frequency range from 150 kHz to 30 MHz was searched.
8. Set the test-receiver system to Peak Detect Function and specified bandwidth (IF Bandwidth = 9kHz) with Maximum Hold Mode. Then measurement is also conducted by Average Detector and Quasi-Peak Detector Function respectively.

3.1.4 Test Setup

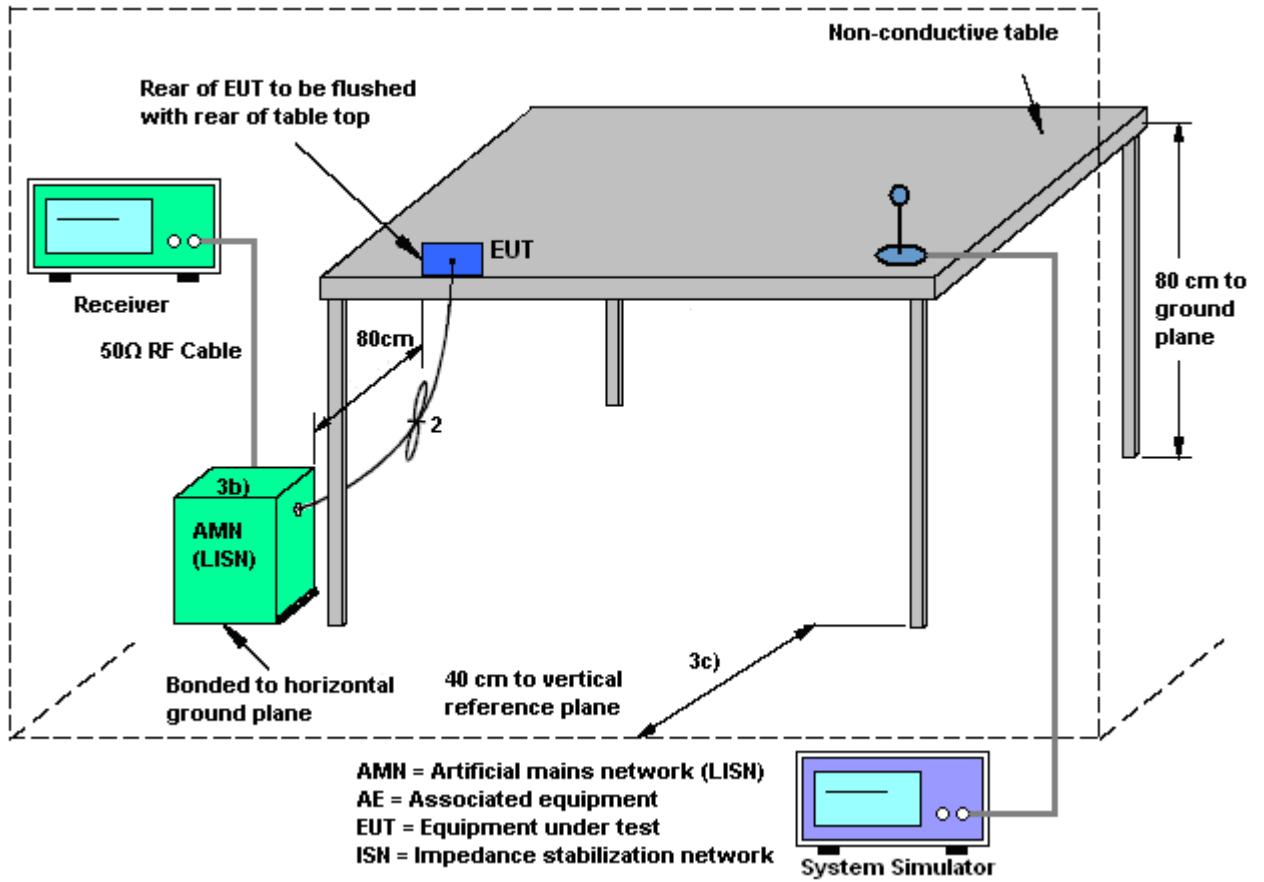



3.1.5 Test Result of AC Conducted Emission

Test Mode :	Mode 12	Temperature :	22~24°C
Test Engineer :	Amos Zhang	Relative Humidity :	42~46%
Test Voltage :	120Vac / 60Hz	Phase :	Line
Function Type :	USB Cable (Charging from Adapter 2) + Earphone 2 + Battery + FM Rx (88MHz) for Sample 1		

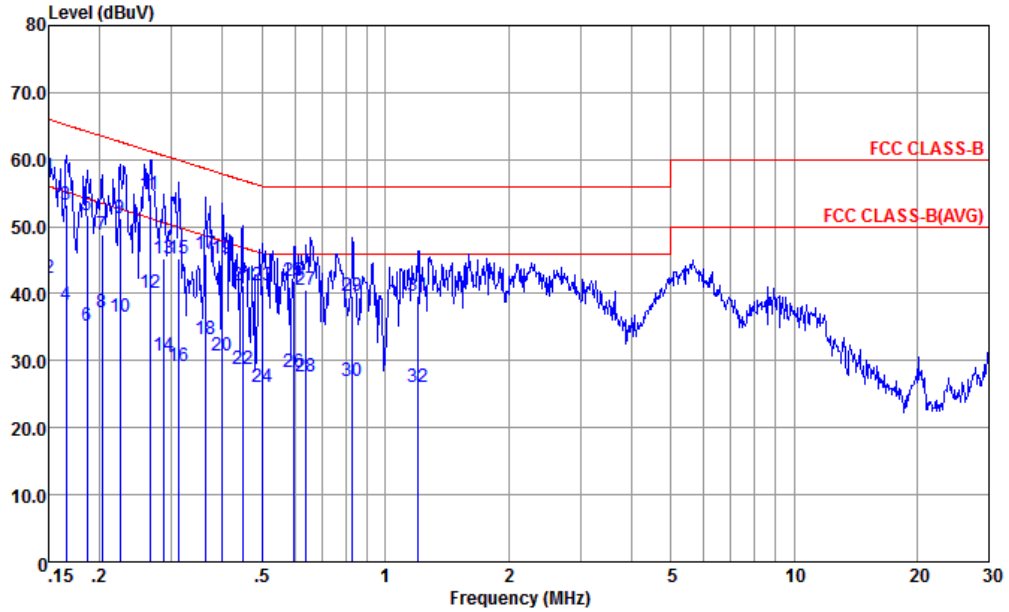

Site : CO01-KS
 Condition : FCC CLASS-B LISN-L-171013-060103 LINE
 Project : (FC) 7D2702-01

: 351854090024592/351854090024600 #9

	Freq	Level	Over Limit	Limit Line	Read Level	LISN Factor	Cable Loss	Remark
	MHz	dBuV	dB	dBuV	dBuV	dB	dB	
1	0.150	57.58	-8.42	66.00	46.80	0.16	10.62	QP
2	0.150	42.28	-13.72	56.00	31.50	0.16	10.62	Average
3	0.166	53.33	-11.83	65.16	42.60	0.17	10.56	QP
4	0.166	38.33	-16.83	55.16	27.60	0.17	10.56	Average
5	0.186	51.79	-12.41	64.20	41.10	0.19	10.50	QP
6	0.186	35.29	-18.91	54.20	24.60	0.19	10.50	Average
7	0.203	48.86	-14.63	63.49	38.21	0.20	10.45	QP
8	0.203	37.26	-16.23	53.49	26.61	0.20	10.45	Average
9	0.224	51.15	-11.51	62.66	40.49	0.21	10.45	QP
10	0.224	36.45	-16.21	52.66	25.79	0.21	10.45	Average
11 *	0.266	54.75	-6.50	61.25	44.09	0.22	10.44	QP
12	0.266	40.15	-11.10	51.25	29.49	0.22	10.44	Average
13	0.288	45.25	-15.34	60.59	34.60	0.22	10.43	QP
14	0.288	30.85	-19.74	50.59	20.20	0.22	10.43	Average
15	0.313	45.25	-14.63	59.88	34.60	0.23	10.42	QP
16	0.313	29.25	-20.63	49.88	18.60	0.23	10.42	Average
17	0.363	45.85	-12.80	58.65	35.20	0.24	10.41	QP



Test Mode :	Mode 12	Temperature :	22~24°C
Test Engineer :	Amos Zhang	Relative Humidity :	42~46%
Test Voltage :	120Vac / 60Hz	Phase :	Line
Function Type :	USB Cable (Charging from Adapter 2) + Earphone 2 + Battery + FM Rx (88MHz) for Sample 1		

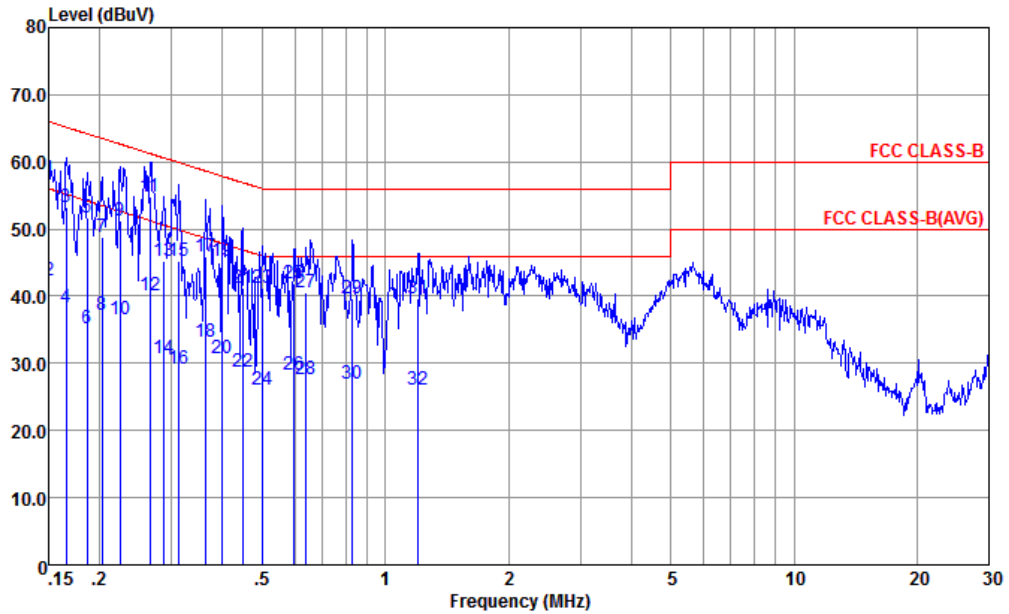

Site : CO01-KS
 Condition : FCC CLASS-B LISN-L-171013-060103 LINE
 Project : (FC) 7D2702-01

: 351854090024592/351854090024600 #9

Freq	Level	Over Limit	Limit	Read	LISN	Cable	Remark
MHz	dBuV	dB	dBuV	dBuV	dB	dB	
18	0.363	33.25	-15.40	48.65	22.60	0.24	Average
19	0.398	45.15	-12.75	57.90	34.49	0.25	QP
20	0.398	30.85	-17.05	47.90	20.19	0.25	Average
21	0.447	41.21	-15.72	56.93	30.60	0.25	QP
22	0.447	28.81	-18.12	46.93	18.20	0.25	Average
23	0.499	41.17	-14.84	56.01	30.60	0.26	QP
24	0.499	26.17	-19.84	46.01	15.60	0.26	Average
25	0.598	41.99	-14.01	56.00	31.50	0.26	QP
26	0.598	28.39	-17.61	46.00	17.90	0.26	Average
27	0.641	40.66	-15.34	56.00	30.20	0.26	QP
28	0.641	27.66	-18.34	46.00	17.20	0.26	Average
29	0.830	39.66	-16.34	56.00	29.30	0.26	QP
30	0.830	26.96	-19.04	46.00	16.60	0.26	Average
31	1.197	39.60	-16.40	56.00	29.19	0.27	QP
32	1.197	26.00	-20.00	46.00	15.59	0.27	Average



Test Mode :	Mode 12	Temperature :	22~24°C
Test Engineer :	Amos Zhang	Relative Humidity :	42~46%
Test Voltage :	120Vac / 60Hz	Phase :	Neutral
Function Type :	USB Cable (Charging from Adapter 2) + Earphone 2 + Battery + FM Rx (88MHz) for Sample 1		

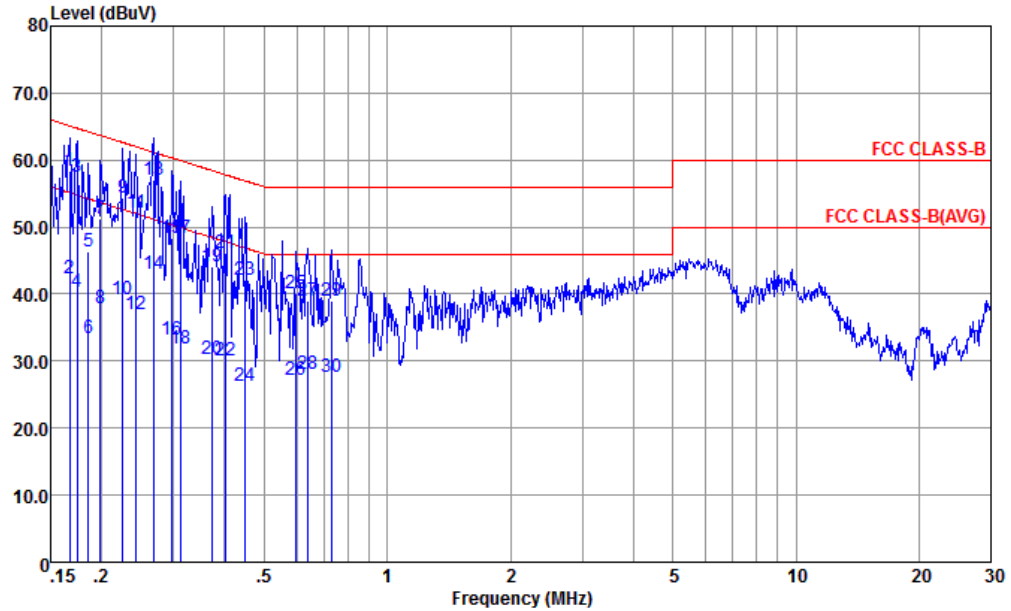

Site : CO01-KS
 Condition : FCC CLASS-B LISN-N-171013-060103 NEUTRAL
 Project : (FC) 7D2702-01

: 351854090024592/351854090024600 #9

	Over	Limit	Read	LISN	Cable		
Freq	Level	Limit	Line	Level	Factor	Loss	Remark
MHz	dBuV	dB	dBuV	dBuV	dB	dB	
1	0.167	58.44	-6.68	65.12	47.60	0.28	10.56 QP
2	0.167	42.44	-12.68	55.12	31.60	0.28	10.56 Average
3	0.174	57.42	-7.35	64.77	46.60	0.28	10.54 QP
4	0.174	40.42	-14.35	54.77	29.60	0.28	10.54 Average
5	0.185	46.28	-17.96	64.24	35.50	0.28	10.50 QP
6	0.185	33.38	-20.86	54.24	22.60	0.28	10.50 Average
7	0.199	51.34	-12.33	63.67	40.60	0.28	10.46 QP
8	0.199	37.94	-15.73	53.67	27.20	0.28	10.46 Average
9	0.226	54.33	-8.28	62.61	43.60	0.28	10.45 QP
10	0.226	39.33	-13.28	52.61	28.60	0.28	10.45 Average
11	0.243	52.22	-9.78	62.00	41.50	0.28	10.44 QP
12	0.243	37.02	-14.98	52.00	26.30	0.28	10.44 Average
13 *	0.267	57.12	-4.08	61.20	46.40	0.28	10.44 QP
14	0.267	42.92	-8.28	51.20	32.20	0.28	10.44 Average
15	0.297	48.31	-12.01	60.32	37.60	0.28	10.43 QP
16	0.297	33.21	-17.11	50.32	22.50	0.28	10.43 Average
17	0.312	48.31	-11.62	59.93	37.61	0.28	10.42 QP



Test Mode :	Mode 12	Temperature :	22~24°C
Test Engineer :	Amos Zhang	Relative Humidity :	42~46%
Test Voltage :	120Vac / 60Hz	Phase :	Neutral
Function Type :	USB Cable (Charging from Adapter 2) + Earphone 2 + Battery + FM Rx (88MHz) for Sample 1		

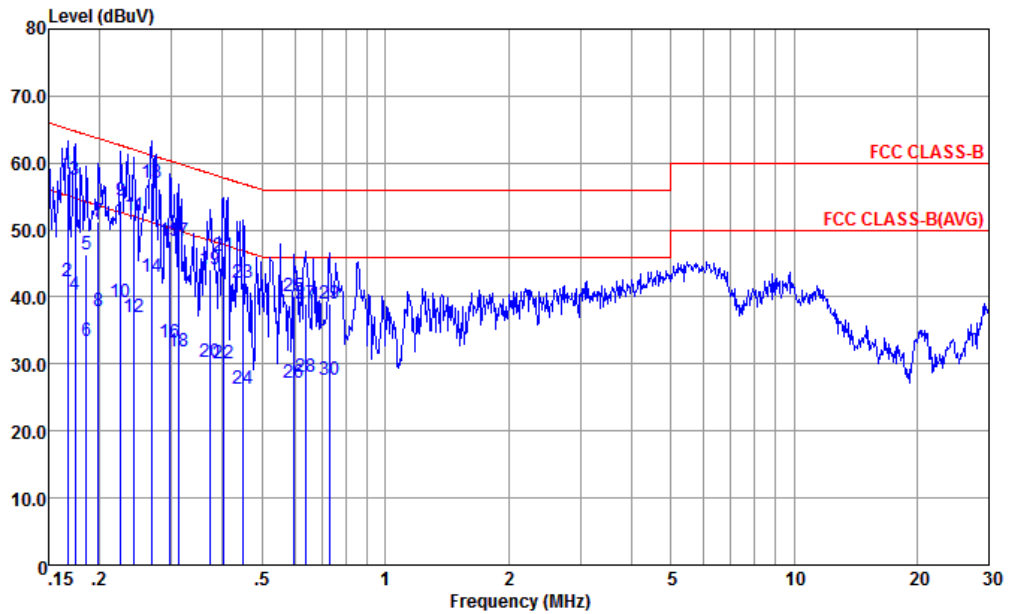

Site : CO01-KS
 Condition : FCC CLASS-B LISN-N-171013-060103 NEUTRAL
 Project : (FC) 7D2702-01

: 351854090024592/351854090024600 #9

	Freq	Level	Over Limit	Limit Line	Read Level	LISN Factor	Cable Loss	Remark
	MHz	dBuV	dB	dBuV	dBuV	dB	dB	
18	0.312	31.91	-18.02	49.93	21.21	0.28	10.42	Average
19	0.373	44.20	-14.23	58.43	33.50	0.29	10.41	QP
20	0.373	30.30	-18.13	48.43	19.60	0.29	10.41	Average
21	0.402	46.19	-11.62	57.81	35.50	0.29	10.40	QP
22	0.402	29.99	-17.82	47.81	19.30	0.29	10.40	Average
23	0.449	42.14	-14.75	56.89	31.49	0.29	10.36	QP
24	0.449	26.24	-20.65	46.89	15.59	0.29	10.36	Average
25	0.595	40.13	-15.87	56.00	29.60	0.30	10.23	QP
26	0.595	27.13	-18.87	46.00	16.60	0.30	10.23	Average
27	0.641	39.10	-16.90	56.00	28.60	0.30	10.20	QP
28	0.641	28.00	-18.00	46.00	17.50	0.30	10.20	Average
29	0.731	39.04	-16.96	56.00	28.60	0.30	10.14	QP
30	0.731	27.64	-18.36	46.00	17.20	0.30	10.14	Average



Test Mode :	Mode 8	Temperature :	22~24°C
Test Engineer :	Amos Zhang	Relative Humidity :	42~46%
Test Voltage :	120Vac / 60Hz	Phase :	Line
Function Type :	LTE Band 7 Idle + Bluetooth Idle + WLAN Idle (2.4G) + USB Cable (Data Link with Notebook) + Earphone 1 + Battery + GNSS Rx + SIM 1 for Sample 1		

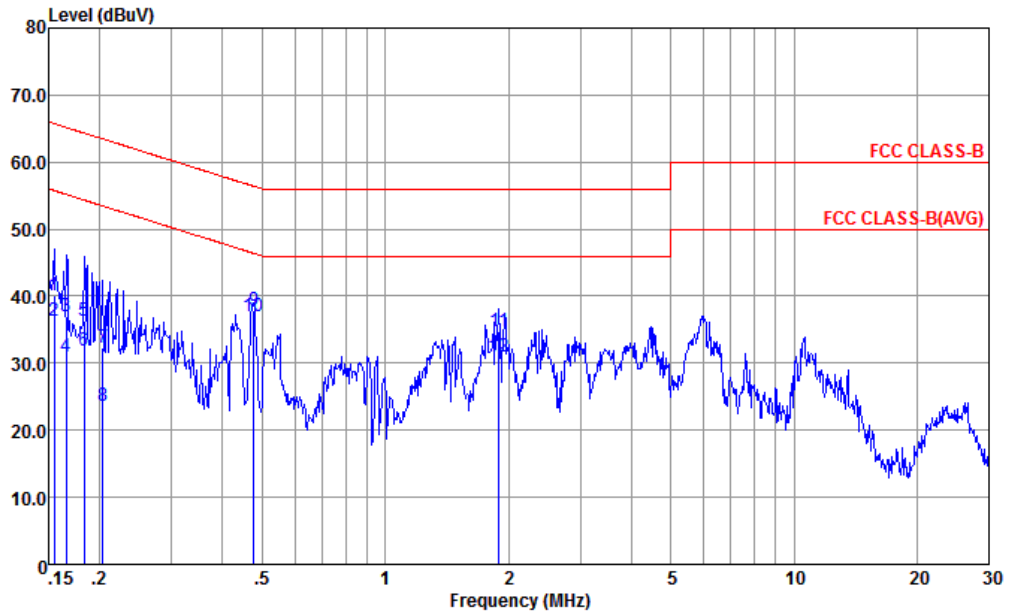

Site : CO01-KS
 Condition : FCC CLASS-B LISN-L-171013-060103 LINE
 Project : (FC) 7D2702-01

 : 351854090024592/351854090024600 #9

	Freq	Level	Over Limit	Limit	Read	LISN	Cable	Loss	Remark
	MHz	dBuV		dB	dBuV	dBuV	dB	dB	
1	0.155	40.06	-25.68	65.74	29.30	0.16	10.60	QP	
2	0.155	36.26	-19.48	55.74	25.50	0.16	10.60	Average	
3	0.166	36.93	-28.23	65.16	26.20	0.17	10.56	QP	
4	0.166	30.93	-24.23	55.16	20.20	0.17	10.56	Average	
5	0.183	36.30	-28.03	64.33	25.60	0.19	10.51	QP	
6	0.183	31.90	-22.43	54.33	21.20	0.19	10.51	Average	
7	0.204	32.26	-31.19	63.45	21.61	0.20	10.45	QP	
8	0.204	23.56	-29.89	53.45	12.91	0.20	10.45	Average	
9	0.476	37.78	-18.63	56.41	27.19	0.26	10.33	QP	
10 *	0.476	37.08	-9.33	46.41	26.49	0.26	10.33	Average	
11	1.898	34.68	-21.32	56.00	24.19	0.28	10.21	QP	
12	1.898	30.88	-15.12	46.00	20.39	0.28	10.21	Average	



Test Mode :	Mode 8	Temperature :	22~24°C
Test Engineer :	Amos Zhang	Relative Humidity :	42~46%
Test Voltage :	120Vac / 60Hz	Phase :	Neutral
Function Type :	LTE Band 7 Idle + Bluetooth Idle + WLAN Idle (2.4G) + USB Cable (Data Link with Notebook) + Earphone 1 + Battery + GNSS Rx + SIM 1 for Sample 1		

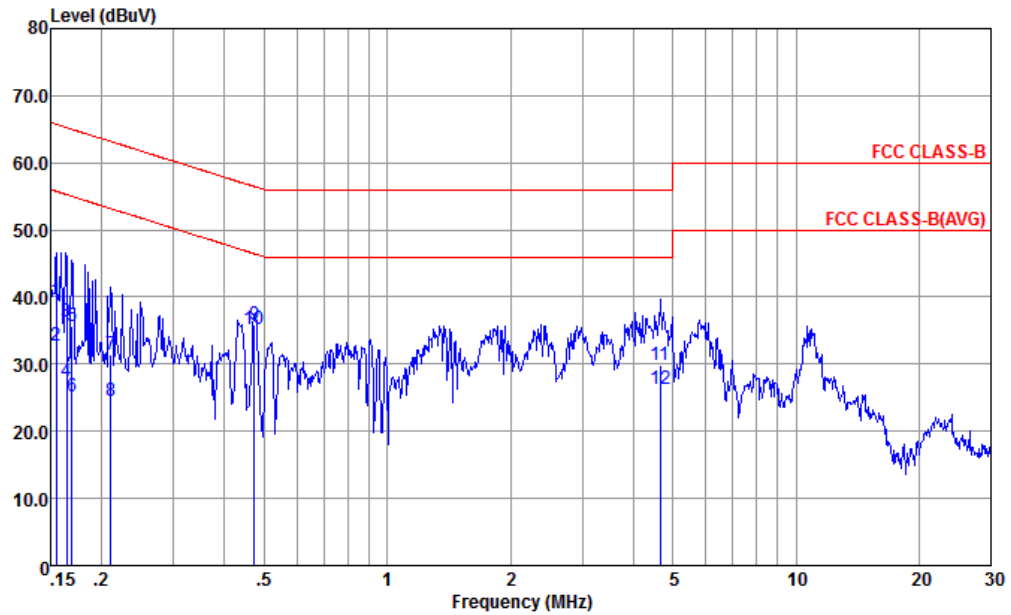

Site : CO01-KS
 Condition : FCC CLASS-B LISN-N-171013-060103 NEUTRAL
 Project : (FC) 7D2702-01

: 351854090024592/351854090024600 #9

	Freq	Level	Over Limit	Limit Line	Read Level	LISN Factor	Cable Loss	Remark
	MHz	dBuV	dB	dBuV	dBuV	dB	dB	
1	0.155	39.48	-26.26	65.74	28.60	0.28	10.60	QP
2	0.155	32.68	-23.06	55.74	21.80	0.28	10.60	Average
3	0.164	36.35	-28.90	65.25	25.50	0.28	10.57	QP
4	0.164	27.45	-27.80	55.25	16.60	0.28	10.57	Average
5	0.169	35.63	-29.36	64.99	24.80	0.28	10.55	QP
6	0.169	25.13	-29.86	54.99	14.30	0.28	10.55	Average
7	0.211	31.33	-31.85	63.18	20.60	0.28	10.45	QP
8	0.211	24.53	-28.65	53.18	13.80	0.28	10.45	Average
9	0.474	35.82	-20.63	56.45	25.20	0.29	10.33	QP
10 *	0.474	35.12	-11.33	46.45	24.50	0.29	10.33	Average
11	4.647	29.75	-26.25	56.00	19.20	0.34	10.21	QP
12	4.647	26.35	-19.65	46.00	15.80	0.34	10.21	Average



3.2. Test of Radiated Emission Measurement

3.2.1. Limit of Radiated Emission

The emissions from an unintentional radiator shall not exceed the field strength levels specified in the following table:

Frequency (MHz)	Field Strength (microvolts/meter)	Measurement Distance (meters)
30 – 88	100	3
88 – 216	150	3
216 - 960	200	3
Above 960	500	3

3.2.2. Measuring Instruments

The measuring equipment is listed in the section 4 of this test report.

3.2.3. Test Procedures

1. The EUT was placed on a turntable with 0.8 meter above ground.
2. The EUT was set 3 meters from the interference receiving antenna, which was mounted on the top of a variable height antenna tower.
3. The table was rotated 360 degrees to determine the position of the highest radiation.
4. The antenna is a Bi-Log antenna and its height is adjusted between one to four meters above ground to find the maximum value of the field strength for both horizontal polarization and vertical polarization of the antenna.
5. For each suspected emission, the EUT was arranged to its worst case and then tune the antenna tower (from 1 m to 4 m) and turntable (from 0 degree to 360 degrees) to find the maximum reading.
6. Set the test-receiver system to Peak Detect Function and specified bandwidth with Maximum Hold Mode (RBW=120kHz/VBW=300kHz for frequency below 1GHz; RBW=1MHz VBW=3MHz (Peak), RBW=1MHz/VBW=10Hz (Average) for frequency above 1GHz).
7. If the emission level of the EUT in peak mode was 3 dB lower than the limit specified, peak values of EUT will be reported. Otherwise, the emission will be repeated by using the quasi-peak method and reported.
8. Emission level (dBµV/m) = 20 log Emission level (µV/m)
9. Corrected Reading: Antenna Factor + Cable Loss + Read Level - Preamp Factor = Level

3.2.4. Test Setup of Radiated Emission

For radiated emissions from 30MHz to 1GHz

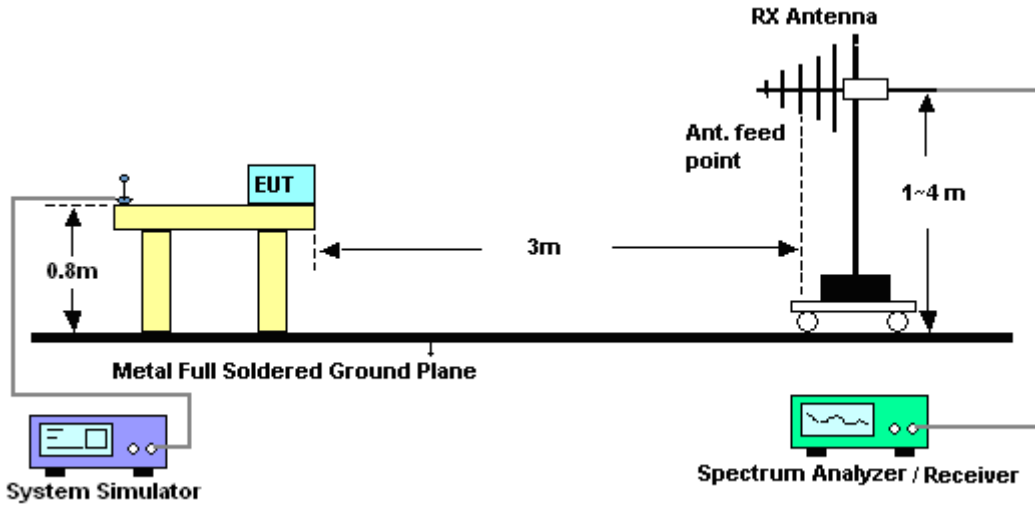

For radiated emissions above 1GHz

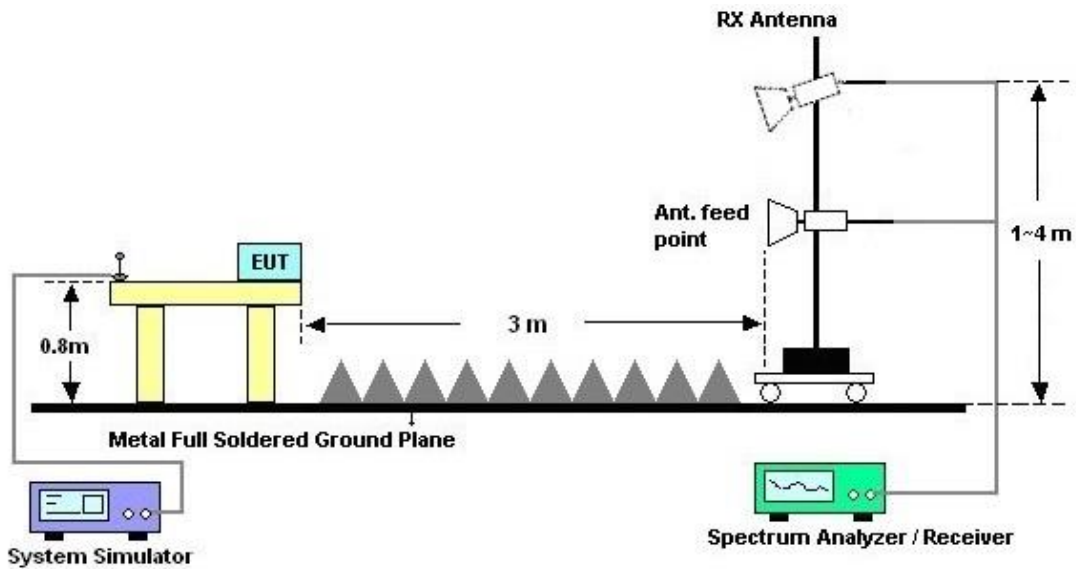



3.2.5. Test Result of Radiated Emission

Test Mode :	Mode 11	Temperature :	21~22°C
Test Engineer :	Maker Qi	Relative Humidity :	41~42%
Test Distance :	3m	Polarization :	Horizontal
Function Type :	USB Cable (Charging from Adapter 1) + Earphone 1 + Battery + FM Rx (108MHz) for Sample 1		
Remark :	#3 is system simulator (FM Option) signal which can be ignored.		

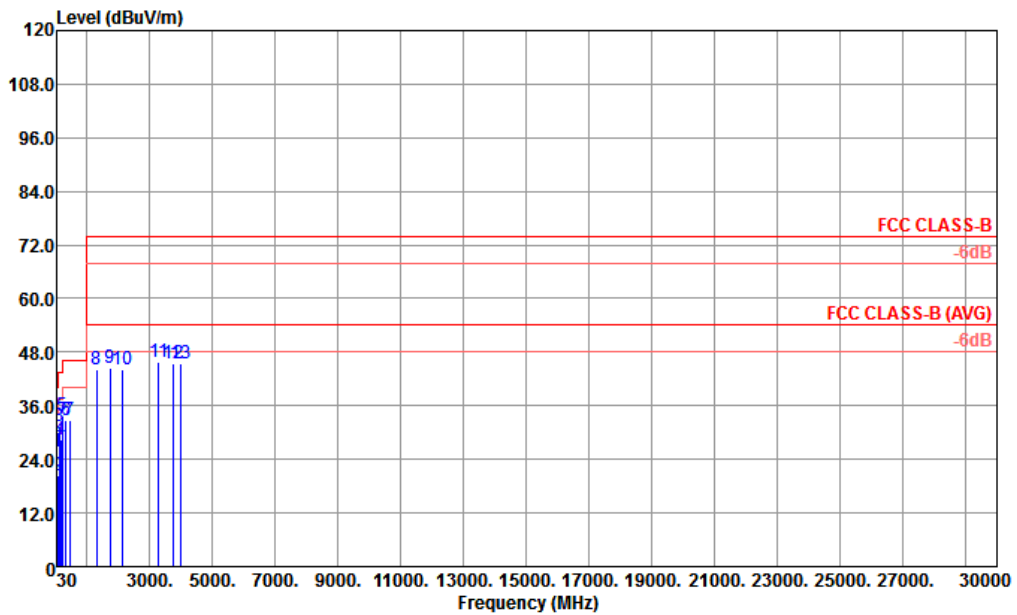

Site : 03CH02-KS
 Condition : FCC CLASS-B 3m LF 47610 HORIZONTAL
 Project : (FC)7D2702-01
 IMEI : 351854090024592 351854090024600 #9

	Freq	Level	Over	Limit	ReadAntenna	Cable	Preamp	A/Pos	T/Pos	Remark	
	MHz	dBuV/m	dB	dBuV/m	dBuV	dB/m	dB	dB	cm	deg	
1	44.58	25.62	-14.38	40.00	40.77	16.30	0.66	32.11	---	---	Peak
2	98.31	20.33	-23.17	43.50	34.87	16.42	1.00	31.96	---	---	Peak
3	108.03	31.46			44.65	17.68	1.05	31.92	---	---	Peak
4	170.13	28.57	-14.93	43.50	43.30	15.70	1.34	31.77	---	---	Peak
5	200.91	33.84	-9.66	43.50	48.67	15.39	1.45	31.67	100	0	Peak
6	337.10	32.60	-13.40	46.00	41.62	20.02	1.91	30.95	---	---	Peak
7	454.00	32.72	-13.28	46.00	38.20	22.85	2.19	30.52	---	---	Peak
8	1316.00	44.00	-30.00	74.00	46.69	28.53	3.78	35.00	---	---	Peak
9	1732.00	44.33	-29.67	74.00	45.06	29.20	4.35	34.28	---	---	Peak
10	2106.00	43.97	-30.03	74.00	41.20	30.65	4.79	32.67	---	---	Peak
11	3285.00	45.92	-28.08	74.00	36.34	33.21	6.24	29.87	---	---	Peak
12	3726.00	45.60	-28.40	74.00	34.57	34.48	6.57	30.02	---	---	Peak
13	4005.00	45.33	-28.67	74.00	33.61	35.12	6.71	30.11	---	---	Peak



Test Mode :	Mode 11	Temperature :	21~22°C
Test Engineer :	Maker Qi	Relative Humidity :	41~42%
Test Distance :	3m	Polarization :	Vertical
Function Type :	USB Cable (Charging from Adapter 1) + Earphone 1 + Battery + FM Rx (108MHz) for Sample 1		
Remark :	#4 is system simulator (FM Option) signal which can be ignored.		

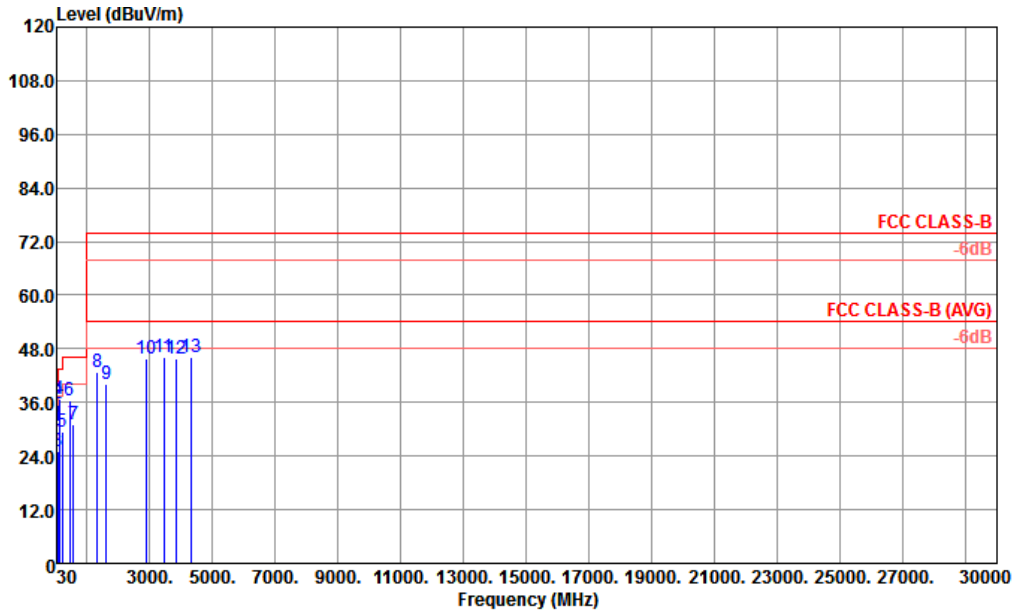

Site : 03CH02-KS
 Condition : FCC CLASS-B 3m LF 47610 VERTICAL
 Project : (FC)7D2702-01
 IMEI : 351854090024592 351854090024600 #9

	Freq	Level	Over	Limit	ReadAntenna	Cable	Preamp	A/Pos	T/Pos	Remark
	MHz	dBuV/m	dB	dBuV/m	dBuV	dB	dB	cm	deg	
1	31.62	31.05	-8.95	40.00	38.60	23.88	0.60	32.03	---	Peak
2	44.58	35.65	-4.35	40.00	50.80	16.30	0.66	32.11	100	243 QP
3	70.23	24.95	-15.05	40.00	43.82	12.30	0.85	32.02	---	Peak
4	108.03	36.63			49.82	17.68	1.05	31.92	---	Peak
5	202.26	29.35	-14.15	43.50	44.18	15.37	1.46	31.66	---	Peak
6	455.40	36.54	-9.46	46.00	41.97	22.88	2.20	30.51	---	Peak
7	576.50	30.94	-15.06	46.00	33.42	24.74	2.59	29.81	---	Peak
8	1336.00	42.91	-31.09	74.00	45.48	28.57	3.81	34.95	---	Peak
9	1620.00	40.15	-33.85	74.00	41.58	29.00	4.23	34.66	---	Peak
10	2892.00	45.74	-28.26	74.00	37.57	32.25	5.90	29.98	---	Peak
11	3456.00	45.99	-28.01	74.00	36.07	33.46	6.32	29.86	---	Peak
12	3822.00	45.80	-28.20	74.00	34.46	34.81	6.64	30.11	---	Peak
13	4302.00	46.07	-27.93	74.00	33.40	35.58	7.21	30.12	---	Peak



Test Mode :	Mode 8	Temperature :	21~22°C
Test Engineer :	Maker Qi	Relative Humidity :	41~42%
Test Distance :	3m	Polarization :	Horizontal
Function Type :	LTE Band 7 Idle + Bluetooth Idle + WLAN Idle (2.4G) + USB Cable (Data Link with Notebook) + Earphone 1 + Battery + GNSS Rx + SIM 1 for Sample 1		

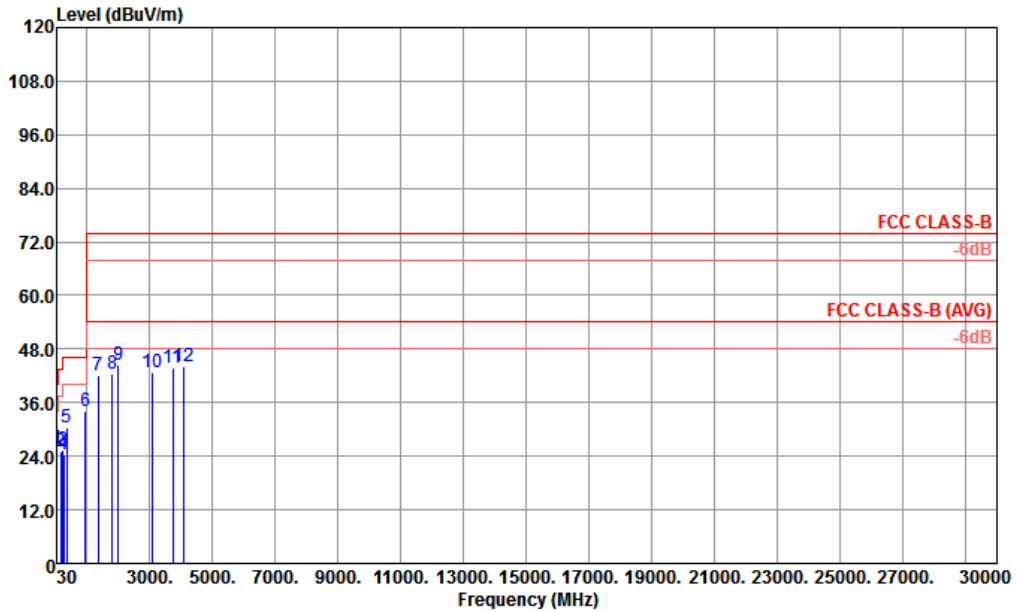

Site : 03CH02-KS
 Condition : FCC CLASS-B 3m LF 47610 HORIZONTAL
 Project : (FC)7D2702-01
 IMEI : 351854090024592 351854090024600 #9

	Freq	Level	Over Limit	Limit Line	ReadAntenna Level	Antenna Factor	Cable Loss	Preamp Factor	A/Pos	T/Pos	Remark
	MHz	dBuV/m	dB	dBuV/m	dBuV	dB/m	dB	dB	cm	deg	
1	43.50	25.59	-14.41	40.00	40.15	16.88	0.66	32.10	---	---	Peak
2	165.27	25.22	-18.28	43.50	39.79	15.90	1.32	31.79	---	---	Peak
3	229.80	25.37	-20.63	46.00	39.04	16.30	1.63	31.60	---	---	Peak
4	254.37	24.49	-21.51	46.00	35.29	18.96	1.76	31.52	---	---	Peak
5	344.80	30.44	-15.56	46.00	39.26	20.19	1.91	30.92	---	---	Peak
6	946.10	34.21	-11.79	46.00	31.30	26.88	3.20	27.17	100	0	Peak
7	1354.00	42.24	-31.76	74.00	44.68	28.60	3.85	34.89	---	---	Peak
8	1810.00	42.61	-31.39	74.00	42.70	29.37	4.46	33.92	---	---	Peak
9	1988.00	44.44	-29.56	74.00	43.04	30.19	4.61	33.40	---	---	Peak
10	3060.00	42.63	-31.37	74.00	33.65	32.74	6.04	29.80	---	---	Peak
11	3744.00	43.90	-30.10	74.00	32.85	34.59	6.57	30.11	---	---	Peak
12	4083.00	44.21	-29.79	74.00	32.15	35.23	6.94	30.11	---	---	Peak



Test Mode :	Mode 8	Temperature :	21~22°C
Test Engineer :	Maker Qi	Relative Humidity :	41~42%
Test Distance :	3m	Polarization :	Vertical
Function Type :	LTE Band 7 Idle + Bluetooth Idle + WLAN Idle (2.4G) + USB Cable (Data Link with Notebook) + Earphone 1 + Battery + GNSS Rx + SIM 1 for Sample 1		

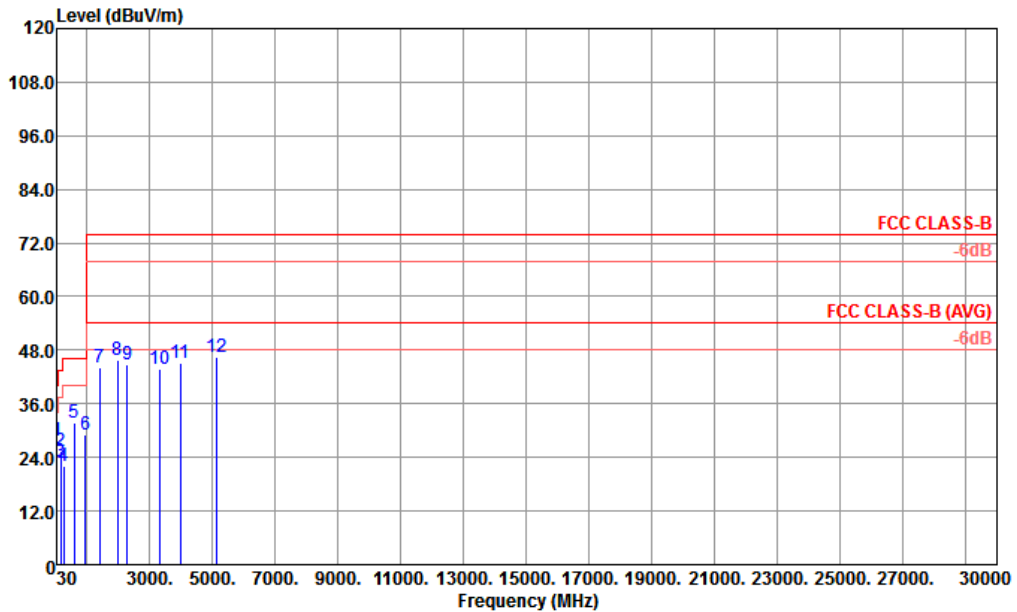

Site : 03CH02-KS
 Condition : FCC CLASS-B 3m LF 47610 VERTICAL
 Project : (FC)7D2702-01
 IMEI : 351854090024592 351854090024600 #9

	Freq	Level	Over Limit	Limit Line	ReadAntenna Level	Antenna Factor	Cable Loss	Preamp Factor	A/Pos	T/Pos	Remark
	MHz	dBuV/m	dB	dBuV/m	dBuV	dB/m	dB	dB	cm	deg	
1	43.50	27.59	-12.41	40.00	42.15	16.88	0.66	32.10	100	0	Peak
2	153.12	25.32	-18.18	43.50	39.50	16.38	1.27	31.83	---	---	Peak
3	165.81	23.13	-20.37	43.50	37.74	15.86	1.32	31.79	---	---	Peak
4	254.91	21.92	-24.08	46.00	32.57	19.10	1.76	31.51	---	---	Peak
5	599.60	31.66	-14.34	46.00	34.10	24.61	2.62	29.67	---	---	Peak
6	953.80	29.01	-16.99	46.00	25.98	26.94	3.21	27.12	---	---	Peak
7	1398.00	43.96	-30.04	74.00	46.16	28.67	3.91	34.78	---	---	Peak
8	1976.00	45.64	-28.36	74.00	44.40	30.07	4.61	33.44	---	---	Peak
9	2276.00	44.69	-29.31	74.00	40.32	31.11	5.02	31.76	---	---	Peak
10	3297.00	43.70	-30.30	74.00	34.09	33.23	6.25	29.87	---	---	Peak
11	3969.00	45.04	-28.96	74.00	33.39	35.06	6.70	30.11	---	---	Peak
12	5142.00	46.41	-27.59	74.00	37.51	35.39	7.77	34.26	---	---	Peak



4. List of Measuring Equipment

Instrument	Manufacturer	Model No.	Serial No.	Characteristics	Calibration Date	Test Date	Due Date	Remark
EMI Receiver	R&S	ESCI7	100768	9kHz~7GHz;	Apr. 20, 2017	Jan. 17, 2018	Apr. 19, 2018	Conduction (CO01-KS)
AC LISN	MessTec	AN3016	060103	9kHz~30MHz	Oct. 13, 2017	Jan. 17, 2018	Oct. 12, 2018	Conduction (CO01-KS)
AC LISN (for auxiliary equipment)	MessTec	AN3016	060105	9kHz~30MHz	Oct. 13, 2017	Jan. 17, 2018	Oct. 12, 2018	Conduction (CO01-KS)
AC Power Source	Chroma	61602	ABP000000 811	AC 0V~300V, 45Hz~1000Hz	Oct. 12, 2017	Jan. 17, 2018	Oct. 11, 2018	Conduction (CO01-KS)
EMI Test Receiver	R&S	ESR7	101403	9kHz~7GHz; Max 30dBm	Aug. 08, 2017	Jan. 26, 2018	Aug. 07, 2018	Radiation (03CH02-KS)
EXA Spectrum Analyzer	Keysight	N9010A	MY551502 08	10Hz~44GHz, MAX 30dB	Apr. 18, 2017	Jan. 26, 2018	Apr. 17, 2018	Radiation (03CH02-KS)
Bilog Antenna	TeseQ	CBL6112D	23182	30MHz~2GHz	Nov. 29, 2017	Jan. 26, 2018	Nov. 28, 2018	Radiation (03CH02-KS)
Double Ridge Horn Antenna	ETS-Lindgren	3117	75957	1GHz~18GHz	Oct. 21, 2017	Jan. 26, 2018	Oct. 20, 2018	Radiation (03CH02-KS)
SHF-EHF Horn	Schwarzbeck	BBHA 9170	BBHA1702 49	15GHz~40GHz	Feb. 15, 2017	Jan. 26, 2018	Feb. 14, 2018	Radiation (03CH02-KS)
Amplifier	SONOMA	310N	187289	9kHz~1GHz	Aug. 07, 2017	Jan. 26, 2018	Aug. 06, 2018	Radiation (03CH02-KS)
Amplifier	Agilent	8449B	3008A0238 4	1-26.5GHz Gain 30dB	Oct. 12, 2017	Jan. 26, 2018	Oct. 11, 2018	Radiation (03CH02-KS)
Amplifier	MITEQ	TTA1840-35-HG	1887435	18GHz~40GHz	Oct. 12, 2017	Jan. 26, 2018	Oct. 11, 2018	Radiation (03CH02-KS)
AC Power Source	Chroma	61601	616010002 473	N/A	NCR	Jan. 26, 2018	NCR	Radiation (03CH02-KS)
Turn Table	MF	MF7802	N/A	0~360 degree	NCR	Jan. 26, 2018	NCR	Radiation (03CH02-KS)
Antenna Mast	MF	MF7802	N/A	1 m~4 m	NCR	Jan. 26, 2018	NCR	Radiation (03CH02-KS)

NCR: No Calibration Required



5. Uncertainty of Evaluation

Uncertainty of Conducted Emission Measurement (150 kHz ~ 30 MHz)

Measuring Uncertainty for a Level of Confidence of 95% ($U = 2Uc(y)$)	2.3dB
---	-------

Uncertainty of Radiated Emission Measurement (30 MHz ~ 1000 MHz)

Measuring Uncertainty for a Level of Confidence of 95% ($U = 2Uc(y)$)	4.5dB
---	-------

Uncertainty of Radiated Emission Measurement (1GHz ~ 18GHz)

Measuring Uncertainty for a Level of Confidence of 95% ($U = 2Uc(y)$)	4.2dB
---	-------

Uncertainty of Radiated Emission Measurement (18GHz ~ 40GHz)

Measuring Uncertainty for a Level of Confidence of 95% ($U = 2Uc(y)$)	4.7dB
---	-------