



# Compliance Testing, LLC

Previously Flom Test Lab

EMI, EMC, RF Testing Experts Since 1963

toll-free: (866) 311-3268

fax: (480) 926-3598

<http://www.ComplianceTesting.com>

[info@ComplianceTesting.com](mailto:info@ComplianceTesting.com)

## Test Report

Prepared for: Proxim Wireless

Model: XB92HPW

Description: 4.9GHz Radio

FCC ID: HZB-XB92WFR

To

FCC Part 90 Y

Date of Issue: July 20, 2016

On the behalf of the applicant:

Proxim Wireless  
47633 Westinghouse Dr  
Fremont, CA 95131

Attention of:

Cor Van de Water, Sr. Regulatory and Compliance Manager  
Ph: (408)383-7626  
E-Mail: [cwater@proxim.com](mailto:cwater@proxim.com)

Prepared By  
Compliance Testing, LLC  
1724 S. Nevada Way  
Mesa, AZ 85204  
(480) 926-3100 phone / (480) 926-3598 fax  
[www.compliancetesting.com](http://www.compliancetesting.com)  
Project No: p1640031

**Alex Macon**  
Project Test Engineer

This report may not be reproduced, except in full, without written permission from Compliance Testing.  
All results contained herein relate only to the sample tested.



### Test Report Revision History

Revision	Date	Revised By	Reason for Revision
1.0	June 23, 2016	Poona Saber	Original Document



## Table of Contents

<u>Description</u>	<u>Page</u>
Standard Test Conditions and Engineering Practices	6
Test Result Summary	8
Carrier Output Power (Conducted)	9
Peak Power Spectral Density	11
Peak Excursion	13
Conducted Spurious Emissions	14
Field Strength of Spurious Radiation	15
Emission Masks (Occupied Bandwidth)	17
Frequency Stability (Temperature and voltage Variation)	18
Test Equipment Utilized	19

**ILAC / A2LA**

Compliance Testing, LLC, has been accredited in accordance with the recognized International Standard ISO/IEC 17025:2005. This accreditation demonstrates technical competence for a defined scope and the operation of a laboratory quality management system (refer to the joint ISO-ILAC-IAF Communiqué dated January 2009).

The tests results contained within this test report all fall within our scope of accreditation, unless noted below.

Please refer to <http://www.compliancetesting.com/labscope.html> for current scope of accreditation.

Testing Certificate Number: **2152.01**



**FCC Site Reg. #349717**

**IC Site Reg. #2044A-2**

**Non-accredited tests contained in this report:**

**N/A**

**The Applicant has been cautioned as to the following:**

**15.21: Information to the User**

The user's manual or instruction manual for an intentional radiator shall caution the user that changes or modifications not expressly approved by the party responsible for compliance could void the user's authority to operate the equipment.

**15.27(a): Special Accessories**

Equipment marketed to a consumer must be capable of complying with the necessary regulations in the configuration in which the equipment is marketed. Where special accessories, such as shielded cables and/or special connectors are required to enable an unintentional or intentional radiator to comply with the emission limits in this part, the equipment must be marketed with, i.e. shipped and sold with, those special accessories. However, in lieu of shipping or packaging the special accessories with the unintentional or intentional radiator, the responsible party may employ other methods of ensuring that the special accessories are provided to the consumer, without an additional charge.

Information detailing any alternative method used to supply the special accessories for a grant of equipment authorization or retained in the verification records, as appropriate. The party responsible for the equipment, as detailed in § 2.909 of this chapter, shall ensure that these special accessories are provided with the equipment. The instruction manual for such devices shall include appropriate instructions on the first page of text concerned with the installation of the device that these special accessories must be used with the device. It is the responsibility of the user to use the needed special accessories supplied with the equipment.

## Test and Measurement Data

The objective is to determine compliance with FCC Part 90, Subpart Y of the Federal Communication Commissions rules. of the Federal Communication Commissions rules.

Maintenance of compliance is the responsibility of the manufacturer. Any modification of the product, which result in lowering the emission, should be checked to ensure compliance has been maintained.

All measurements contained in this report were conducted with ANSI C63.4, American National Standard for Methods of Measurement of Radio-Noise Emissions from Low-Voltage Electrical and Electronic Equipment in the range of 9 kHz to 40 GHz. The public notice KDB 789033 D02 v01r02 for Unlicensed National Information Infrastructure (U-NII) Devices shall be performed also.

## Standard Test Conditions and Engineering Practices

Except as noted herein, the following conditions and procedures were observed during the testing.

In accordance with ANSI/TIA 603C, and unless otherwise indicated in the specific measurement results, the ambient temperature of the actual EUT was maintained within the range of 10° to 40°C (50° to 104°F) unless the particular equipment requirements specified testing over a different temperature range. Also, unless otherwise indicated, the humidity levels were in the range of 10% to 90% relative humidity.

Environmental Conditions		
Temp (°C)	Humidity (%)	Pressure (mbar)
23.8 – 24.5	21 - 28	961 - 968

Measurement results, unless otherwise noted, are worst-case measurements.

### EUT Description

**Model:** 4.9GHz Radio

**Description:** 4.9GHz Radio

**Firmware:** N/A

**Software:** N/A

**Serial Number:** N/A

**Additional Information:** The EUT is a 2x2 MIMO device powered by POE. The antenna gain is 13.5 dBi

### EUT Operation during Tests

The EUT was controlled using the manufacturers HTML terminal



**Accessories:**

Qty	Description	Manufacturer	Model	S/N
1	POE Power Supply	SL Power	PENB1032E4800F02	N/A

**Cables:**

Qty	Description	Length (M)	Shielding Y/N	Shielded Hood Y/N	Termination
2	Ethernet cable	<3m	N	N	N/A

**Modifications:** None



## Test Result Summary

Specification	Test Name	Pass, Fail, N/A	Comments
90.205 90.1215	Carrier Output Power (Conducted)	Pass	
90.205, 90.1215	Peak Power Spectral Density	Pass	
90.1215	Peak Excursion	Pass	
2.1051 90.210	Unwanted Emissions (Transmitter Conducted)	Pass	
2.1053 90.210	Field Strength of Spurious Radiation	Pass	
90.210, 2.1049	Emission Masks (Occupied Bandwidth)	Pass	
90.209	Bandwidth	Pass	
2.1055 90.213	Frequency Stability (Temperature Variation)	Pass	
2.1055 90.213	Frequency Stability (Voltage Variation)	Pass	



**Carrier Output Power (Conducted)**

**Engineer:** Poona Saber

**Test Date:** 6/17/16

**Test Requirements**

According to § 90.1215 (a)

(1) The maximum conducted output power should not exceed:

Channel Bandwidth (MHz)	Low Power Maximum Conducted Output Power (dBm)
5	14
10	17
20	20

(2) Low power devices are also limited to a peak power spectral density of 8 dBm per one MHz. Low power devices using channel bandwidths other than those listed above are permitted; however, they are limited to a peak power spectral density of 8 dBm/MHz. If transmitting antennas of directional gain greater than 9 dBi are used, both the maximum conducted output power and the peak power spectral density should be reduced by the amount in decibels that the directional gain of the antenna exceeds 9 dBi.

**Measurement Procedure**

The Equipment Under Test (EUT) was connected to a spectrum analyzer through a 30 dB Power attenuator. All cable and attenuator losses were input into the spectrum analyzer as a reference level offset to ensure accurate readings were obtained.

The RF power was calculated using the spectrum analyzers' band power function per Method SA-1 from KDB 789033 D02 General U-NII Test Procedures New Rules v01. Measurements were made at the low, mid, and high channels of the band.

**The Spectrum Analyzer was set to the following:**

- a. RBW = 1 MHz
- b. VBW ≥ 3 MHz
- c. Sweep time = auto
- d. Detector = RMS
- e. 100 traces in power averaging mode

The EUT incorporates a 13.5 dBi antenna.

**Test Setup**

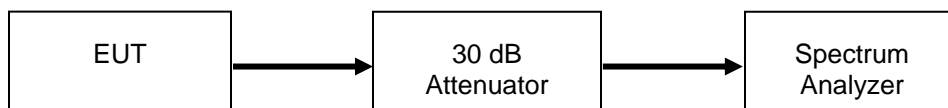



### Low Power Transmitter Peak Output Power

Bandwidth	Test Frequency	TP	JA Measured Level	JB Measured Level	JA Measured Level	JB Measured Level	Combined Output Power	Limit	Margin
MHz	MHz		dBm	dBm	mW	mW	dBm	dBm	dB
5	4942.5	7.5	3.4	6.2	2.2	4.2	8.0	9.5	-1.5
5	4967.5	7.5	3.2	5.9	2.1	3.9	7.8	9.5	-1.7
5	4987.5	7.5	3.4	6.0	2.2	4.0	7.9	9.5	-1.6
10	4945	9.5	8.6	9.5	7.2	8.9	12.1	12.5	-0.4
10	4965	9.5	8.5	9.3	7.1	8.6	11.9	12.5	-0.6
10	4985	9	7.5	9.0	5.6	7.9	11.3	12.5	-1.2
20	4950	13	11.6	12.2	14.5	16.7	14.9	15.5	-0.6
20	4965	13	11.7	12.3	14.8	16.8	15.0	15.5	-0.5
20	4980	13	11.6	12.1	14.6	16.2	14.9	15.5	-0.6

**Peak Power Spectral Density**

**Engineer:** Poona Saber

**Test Date:** 6/17/16

**Test Requirements**

According to § 90.1215 (a)

(1) The maximum Power Spectral Density should not exceed:

Channel Bandwidth (MHz)	Low Power Maximum Conducted Output Power (dBm)
5	8
10	8
20	8

(2) Low power devices are also limited to a peak power spectral density of 8 dBm per one MHz. Low power devices using channel bandwidths other than those listed above are permitted; however, they are limited to a peak power spectral density of 8 dBm/MHz. If transmitting antennas of directional gain greater than 9 dBi are used, both the maximum conducted output power and the peak power spectral density should be reduced by the amount in decibels that the directional gain of the antenna exceeds 9 dBi.

**Measurement Procedure**

The Equipment Under Test (EUT) was connected to a spectrum analyzer through a 30 dB Power attenuator. All cable and attenuator losses were input into the spectrum analyzer as a reference level offset to ensure accurate readings were obtained.

The Power Spectral Density was measured using the method per SA-1 from KDB 789033 D02 General U-NII Test Procedures New Rules v01. Measurements were made at the low, mid, and high channels of the band. The maximum PSD was determine by finding the peak value across the carrier bandwidth.

**The Spectrum Analyzer was set to the following:**

- a. RBW = 1 MHz
- b. VBW ≥ 3 MHz
- c. Span 1.5 \* BW
- d. Sweep time = auto
- e. Detector = RMS
- f. 100 traces in power averaging mode

The EUT incorporates a 13.5 dBi antenna.

**Test Setup**

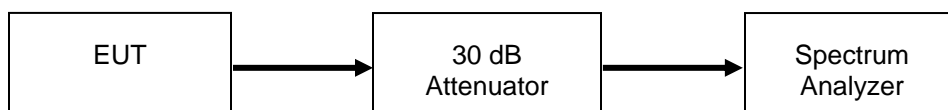



**Low Power Transmitter Power Spectral Density**

Bandwidth	Test Frequency	TP	JA Measured Level	JB Measured Level	JA Measured Level	JB Measured Level	Combined Output Power	Limit	Margin
MHz	MHz		dBm	dBm	mW	mW	dBm	dBm	dB
5	4942.5	7.5	-2.1	0.6	0.6	1.1	2.5	3.5	-1.0
5	4967.5	7.5	-2.0	0.3	0.6	1.1	2.3	3.5	-1.2
5	4987.5	7.5	-2.0	0.4	0.6	1.1	2.4	3.5	-1.1
10	4945	9.5	0.2	0.8	1.0	1.2	3.5	3.5	0.0
10	4965	9.5	0.0	0.9	1.0	1.2	3.5	3.5	0.0
10	4985	9	-0.9	0.4	0.8	1.1	2.8	3.5	-0.7
20	4950	12	0.2	0.7	1.0	1.2	3.5	3.5	0.0
20	4965	12	0.2	0.7	1.1	1.2	3.5	3.5	0.0
20	4980	12	0.3	0.6	1.1	1.1	3.5	3.5	0.0

## Peak Excursion

**Engineer:** Poona Saber

**Test Date:** 6/20/16

### Test Requirements

According to 90.1215 (e) the ratio of the peak excursion of the modulation envelope (measured using a peak hold function) to the maximum conducted output power shall not exceed 13 dB across any 1 MHz bandwidth or the emission bandwidth whichever is less.

### Test Procedure

1. Set the spectrum analyzer or EMI receiver span to view the entire emission bandwidth.
2. Find the maximum of the peak-max-hold spectrum.
3. Set RBW = 1 MHz.
4. VBW  $\geq$  3 MHz.
5. Detector = peak.
6. Trace mode = max-hold.
7. Allow the sweeps to continue until the trace stabilizes.
8. Use the peak search function to find the peak of the spectrum.
9. Compute the ratio of the modulation envelope (measured using a peak hold function) to the maximum conducted output power

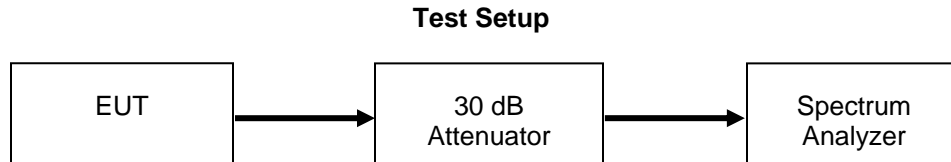

**See Annex A for Test Results**

## Conducted Spurious Emissions

**Engineer:** Alex Macon

**Test Date:** 5/13/16

### Standard Applicable

According to § 90.210 Emission masks L:

On any frequency removed from the assigned frequency above 150% of the authorized bandwidth: 40 dB.

### Test Procedure

The EUT was connected directly to a spectrum analyzer to verify that the UUT met the requirements for spurious emissions. A tunable notch filter was utilized to ensure the fundamental did not put the spectrum analyzer into compression. The resolution bandwidth set for 100 kHz < 1GHz and 1MHz >1 GHz the reference level was adjusted to ensure the system had sufficient dynamic range to measure spurious emissions. The frequency range from 30 MHz to the 10<sup>th</sup> harmonic of the fundamental transmitter was observed and plotted.

### Test Setup

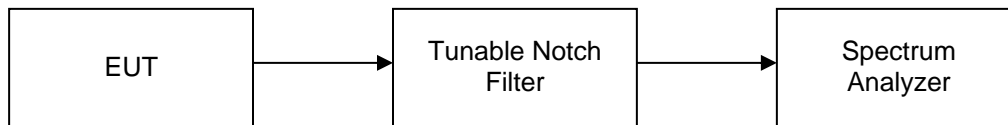

**See Annex B for Test Results**



## Field Strength of Spurious Radiation

Engineer: Alex Macon

Test Date: 6/24/16

### Test Procedure

- A) Connect the equipment as illustrated below.
- B) Adjust the spectrum analyzer to the following settings:
  - 1) Resolution Bandwidth 100 kHz (< 1 GHz), 1 MHz (> 1GHz)
  - 2) Video Bandwidth  $\geq 3$  times Resolution Bandwidth, or 30 kHz
  - 3) Sweep Speed  $\leq 2000$  Hz/second
  - 4) Detector Mode = Mean or Average Power
- C) Place the transmitter to be tested on the turntable in the standard test site. The transmitter is transmitting into a non-radiating load that is placed on the turntable. The RF cable to this load should be of minimum length.
- D) For each spurious measurement the test antenna should be adjusted to the correct length for the frequency involved. This length may be determined from a calibration ruler supplied with the equipment. Measurements shall be made from the lowest radio frequency generated in the equipment to the tenth harmonic of the carrier, except for the region close to the carrier equal to  $\pm$  the test bandwidth (see Section 1.3.4.4).
- E) For each spurious frequency, raise and lower the test antenna from 1 m to 4 m to obtain a maximum reading on the spectrum analyzer with the test antenna at horizontal polarity. Repeat this procedure to obtain the highest possible reading. Record this maximum reading.
- F) Repeat Step E) for each spurious frequency with the test antenna polarized vertically.
- G) Reconnect the equipment as illustrated.
- H) Keep the spectrum analyzer adjusted as in Step B).
- I) Remove the transmitter and replace it with a substitution antenna (the antenna should be half wavelength for each frequency involved). The center of the substitution antenna should be approximately at the same location as the center of the transmitter. At lower frequencies, where the substitution antenna is very long, this will be impossible to achieve when the antenna is polarized vertically. In such case the lower end of the antenna should be 0.3 m above the ground.
- J) Feed the substitution antenna at the transmitter end with a signal generator connected to the antenna by means of a non-radiating cable. With the antennas at both ends horizontally polarized and with the signal generator tuned to a particular spurious frequency, raise and lower the test antenna to obtain a maximum reading at the spectrum analyzer. Adjust the level of the signal generator output until the previously recorded maximum reading for this set of conditions is obtained. This should be done carefully repeating the adjustment of the test antenna and generator output.
- K) Repeat Step J) with both antennas vertically polarized for each spurious frequency.
- L) Calculate power in dBm into a reference ideal half-wave dipole antenna by reducing the readings obtained in Steps J) and K) by the power loss in the cable between the generator and the antenna and further corrected for the gain of the substitution antenna used relative to an ideal half-wave dipole antenna.
- M) The levels recorded in Step L) are absolute levels of radiated spurious emissions in dBm. The radiated spurious emissions in dB can be calculated by the following:

$$\text{Radiated spurious emissions dB} = 10\log_{10} (\text{TX power in watts}/0.001) - \text{the levels in Step I)}$$

*NOTE: It is permissible that the other antennas provided can be referenced to a dipole.*

**Test Setup**

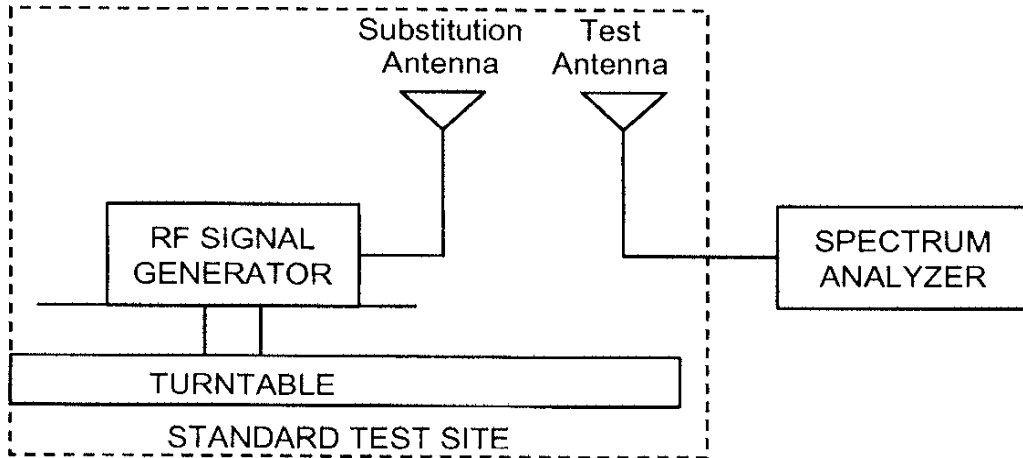
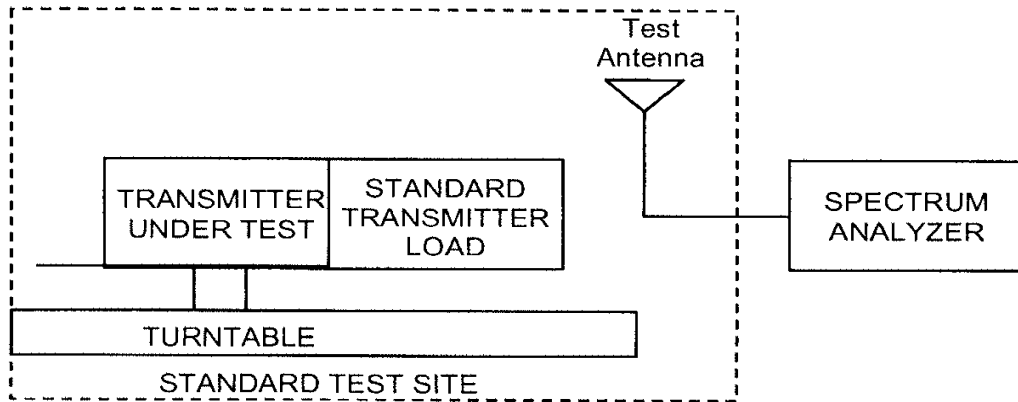

See Annex C for Test Results



## Emission Masks (Occupied Bandwidth)

**Engineer:** Poona Saber

**Test Date:** 6/20/16

### Measurement Procedure

According to 90.209 Bandwidth limitations this test was performed to measure transmitter occupied bandwidth and the EUT was connected directly to a spectrum analyzer to verify that the EUT meets the required emissions mask. L

**For the Emissions Band width measurements the spectrum analyzer was set to the following parameters:**

- 1) Set RBW = approximately 1% of the emission bandwidth.
- 2) Set the VBW > RBW.
- 3) Trace mode = max hold.
- 4) Measure the maximum width of the emission that is 26 dB down from the peak of the emission. Compare this with the RBW setting of the analyzer. Readjust RBW and repeat measurement as needed until the RBW/EBW ratio is approximately 1%.

**For the Emissions Mask measurements the spectrum analyzer was set to the following parameters:**

- 1) Set RBW = 100kHz
- 2) Set the VBW= 30kHz
- 3) Trace mode = max hold.
- 4) Measure the maximum width of the emission that is 26 dB down from the peak of the emission. Compare this with the RBW setting of the analyzer. Readjust RBW and repeat measurement as needed until the RBW/EBW ratio is approximately 1%.

### Test Setup

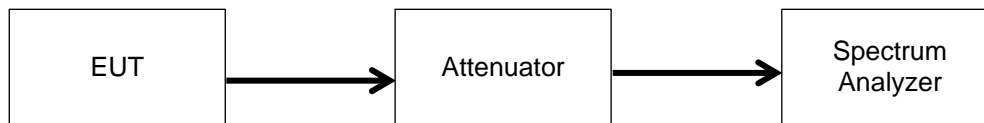

**See Annex D for Test Results**

**Frequency Stability (Temperature and Voltage Variation)**

**Engineer:** Poona Saber

**Test Date:** 6/21/16

**Measurement Procedure**

The EUT was placed in an environmental test chamber and the RF output was connected directly to a spectrum analyzer. The temperature was varied from -30°C to 50°C in 10°C increments. After a sufficient time for temperature stabilization the RF output frequency was measured. At 20°C the power supply voltage to the EUT was varied from 85% to 115% of the nominal value and the RF output was measured.

**Measurement Setup**

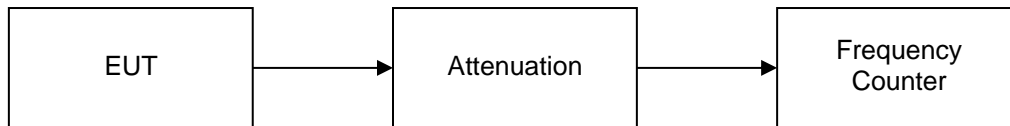

**See Annex E for Test Results**



## Test Equipment Utilized

Description	Manufacturer	Model #	CT Asset #	Last Cal Date	Cal Due Date
Temperature Chamber	Tenney	Tenney Jr	i00027	Verified on: 6/20/16	
Horn Antenna	EMCO	3115	i00103	1/20/15	1/20/17
Horn Antenna, Amplified	ARA	MWH-1826/B	i00273	4/22/15	4/22/18
Humidity / Temp Meter	Newport	IBTHX-W-5	i00282	5/26/16	5/26/17
Spectrum Analyzer	Agilent	E4407B	i00331	9/18/15	9/18/16
Data Logger	Fluke	Hydra Data Bucket	i00343	4/5/16	4/5/17
Bi-Log Antenna	Schaffner	CBL 6111D	i00349	10/19/15	10/19/17
EMI Analyzer	Agilent	E7405A	i00379	2/11/16	2/11/17
3 Meter Semi-Anechoic Chamber	Panashield	3 Meter Semi-Anechoic Chamber	i00428	7/27/14	7/27/16
PSA Spectrum Analyzer	Agilent	E4445A	i00471	8/26/15	8/26/16
Preamplifier for 1-18GHz horn antenna	Miteq	AFS44 00101 400 23-10P-44	i00509	N/A	N/A

In addition to the above listed equipment standard RF connectors and cables were utilized in the testing of the described equipment. Prior to testing these components were tested to verify proper operation.

END OF TEST REPORT