

# **FCC RADIO TEST REPORT**

according to

47 CFR FCC Part 15 Subpart C § 15.247

**Equipment** : PDA Scanner  
**Model No.** : PA966BTG, PA967BTG  
**Brand Name** : unitech  
**Filing Type** : New Application  
**Applicant** : unitech electronics co., ltd.  
3F, No.236, Shinhu 2<sup>nd</sup> Rd., Neihu Chiu, Taipei, Taiwan114, R.O.C.  
**FCC ID** : HLEPA966BTG  
**Manufacturer** : unitech electronics co., ltd.  
5F, No.136, Lane 235, Pao-Chiao Rd., Hsin-Tien, Taiwan 231  
R.O.C.  
**Received Date** : Jan. 28, 2007  
**Final Test Date** : Aug. 14, 2007

## Statement

**Test result included is only for the 802.11b/g part of the product.**

The test result in this report refers exclusively to the presented test model / sample.

Without written approval of SPORTON International Inc., the test report shall not be reproduced except in full.

The measurements and test results shown in this test report were made in accordance with the procedures and found in compliance with the limit given in **ANSI C63.4-2003** and **47 CFR FCC Part 15 Subpart C**.

The test equipment used to perform the test is calibrated and traceable to NML/ROC.



***SPORTON International Inc.***

*6F, No. 106, Sec. 1, Hsin Tai Wu Rd., Hsi Chih, Taipei Hsien, Taiwan, R.O.C.*

**Table of Contents**

**1. SUMMARY OF THE TEST RESULT ..... 2**

**2. GENERAL INFORMATION..... 3**

2.1. Product Details ..... 3

2.2. Accessories ..... 3

2.3. Table for Filed Antenna ..... 3

2.4. Table for Carrier Frequencies ..... 4

2.5. Table for Test Modes ..... 4

2.6. Table for Testing Locations ..... 5

2.7. Table for Supporting Units..... 5

2.8. Table for Parameters of Test Software Setting ..... 5

2.9. EUT Operation during Test ..... 5

2.10. Test Configurations ..... 6

**3. TEST RESULT ..... 8**

3.1. AC Power Line Conducted Emissions Measurement..... 8

3.2. Maximum Peak Output Power Measurement..... 12

3.3. Power Spectral Density Measurement ..... 14

3.4. 6dB Spectrum Bandwidth Measurement..... 19

3.5. Radiated Emissions Measurement..... 24

3.6. Band Edge Emissions Measurement ..... 42

3.7. Antenna Requirements..... 47

**4. LIST OF MEASURING EQUIPMENTS ..... 48**

**5. TEST LOCATION..... 49**

**6. TAF CERTIFICATE OF ACCREDITATION ..... 50**

**APPENDIX A. COLLECTION REPORT (WLAN WITH BT)..... A1 ~ A14**

**APPENDIX B. TEST PHOTOS ..... B1 ~ B6**

**APPENDIX C. PHOTOGRAPHS OF EUT ..... C1 ~ C49**

### History of This Test Report

Original Issue Date: Aug. 16, 2007

Report No.: FR711905-01AC

No additional attachment.

Additional attachment were issued as following record:

Attachment No.	Issue Date	Description

# **CERTIFICATE OF COMPLIANCE**

according to

47 CFR FCC Part 15 Subpart C § 15.247

Equipment : PDA Scanner  
Model No. : PA966BTG, PA967BTG  
Brand Name : unitech  
Applicant : unitech electronics co., **ltd.**  
3F, No.236, Shinhu 2<sup>nd</sup> Rd., Neihu Chiu, Taipei, Taiwan114, R.O.C.

Sporton International as requested by the applicant to evaluate the EMC performance of the product sample received on Jan. 28, 2007 would like to declare that the tested sample has been evaluated and found to be in compliance with the tested rule parts. The data recorded as well as the test configuration specified is true and accurate for showing the sample's EMC nature.



Wayne Hsu

***SPORTON International Inc.***

*6F, No.106, Sec. 1, Hsin Tai Wu Rd., Hsi Chih, Taipei Hsien, Taiwan, R.O.C.*

**1. SUMMARY OF THE TEST RESULT**

<b>Applied Standard: 47 CFR FCC Part 15 Subpart C</b>				
<b>Part</b>	<b>Rule Section</b>	<b>Description of Test</b>	<b>Result</b>	<b>Under Limit</b>
3.1	15.207	AC Power Line Conducted Emissions	Complies	13.04 dB
3.2	15.247(b)(3)	Maximum Peak Conducted Output Power	Complies	11.43 dB
3.3	15.247(e)	Power Spectral Density	Complies	16.29 dB
3.4	15.247(a)(2)	6dB Spectrum Bandwidth	Complies	-
3.5	15.247(d)	Radiated Emissions	Complies	3.18 dB
3.6	15.247(d)	Band Edge Emissions	Complies	4.65 dB
3.7	15.203	Antenna Requirements	Complies	-

<b>Test Items</b>	<b>Uncertainty</b>	<b>Remark</b>
AC Power Line Conducted Emissions	±2.3dB	Confidence levels of 95%
Maximum Peak Conducted Output Power	±0.8dB	Confidence levels of 95%
Power Spectral Density	±0.5dB	Confidence levels of 95%
6dB Spectrum Bandwidth	±8.5×10 <sup>-8</sup>	Confidence levels of 95%
Radiated Emissions (9kHz~30MHz)	±0.8dB	Confidence levels of 95%
Radiated Emissions (30MHz~1000MHz)	±1.9dB	Confidence levels of 95%
Radiated / Band Edge Emissions (1GHz~18GHz)	±1.9dB	Confidence levels of 95%
Radiated Emissions (18GHz~40GHz)	±1.9dB	Confidence levels of 95%
Temperature	±0.7°C	Confidence levels of 95%
Humidity	±3.2%	Confidence levels of 95%
DC / AC Power Source	±1.4%	Confidence levels of 95%

**2. GENERAL INFORMATION**

**2.1. Product Details**

There are two difference models (model name: PA966BTG and PA967BTG), The difference between these two models is “PA966BTG is handheld, PA967BTG is gun grip”. Only the radio detail of WLAN is shown in the table below. For more detailed features description, please refer to the manufacturer’s specifications or user’s manual.

Items	Description
Power Type	7.4Vdc from Li-ion Battery; 12Vdc from adapter
Modulation	DSSS for IEEE 802.11b ; OFDM for IEEE 802.11g
Data Modulation	DSSS (BPSK / QPSK / CCK) ; OFDM (BPSK / QPSK / 16QAM / 64QAM)
Data Rate (Mbps)	DSSS (1/ 2/ 5.5/11) ; OFDM (6/9/12/18/24/36/48/54)
Frequency Range	2400 ~ 2483.5MHz
Channel Number	11
Channel Band Width (99%)	11b: 12.56 MHz ; 11g: 16.44 MHz
Conducted Output Power	11b: 18.57 dBm ; 11g: 17.88 dBm

**2.2. Accessories**

Power	Brand	Model	Rating
Switching Adapter	DVE	DSA-0421S-12 1	INPUT: 100-240V ~50/60Hz, 1.2A 60VA OUTPUT: 12V 2A
Li-ion Battery	-	-	7.4Vdc
Others			
Cradle / Power Cable / USB Cable			

**2.3. Table for Filed Antenna**

Ant.	Antenna Type	Connector	Gain (dBi)	Remark
1	Printed	UFL	-1.48	TX & RX
2	PIFA	UFL	0.33	RX

2.4. Table for Carrier Frequencies

Frequency Band	Channel No.	Frequency	Channel No.	Frequency
2400~2483.5MHz	1	2412 MHz	7	2442 MHz
	2	2417 MHz	8	2447 MHz
	3	2422 MHz	9	2452 MHz
	4	2427 MHz	10	2457 MHz
	5	2432 MHz	11	2462 MHz
	6	2437 MHz		

2.5. Table for Test Modes

Preliminary tests were performed in different data rate to find the worst radiated emission. The data rate shown in the table below is the worst-case rate with respect to the specific test item. Investigation has been done on all the possible configurations for searching the worst cases. The following table is a list of the test modes shown in this test report.

Test Items	Mode	Data Rate	Channel	Antenna
AC Power Line Conducted Emissions	Mode 4	11 Mbps	6	1
Maximum Peak Conducted Output Power Power Spectral Density 6dB Spectrum Bandwidth	11b/CCK	11 Mbps	1/6/11	NA
	11g/BPSK	6 Mbps	1/6/11	NA
Radiated Emissions 9kHz~1GHz	Mode 1 / 11g/BPSK	6 Mbps	6	1
Radiated Emissions 1GHz~10 <sup>th</sup> Harmonic	11b/CCK	11 Mbps	1/6/11	1
	11g/BPSK	6 Mbps	1/6/11	1
Band Edge Emissions	11b/CCK	11 Mbps	1/6/11	1
	11g/BPSK	6 Mbps	1/6/11	1

Note:

For AC Power Conducted Emissions test, the following modes were tested:

- Mode 1. Without handheld (PA966BTG)
- Mode 2. Without handheld+ Cradle (USB Link+BT Link) (PA966BTG)
- Mode 3. With handheld (PA967BTG)
- Mode 4. With handheld+ Cradle (USB Link+BT Link) (PA967BTG)

**Because "mode 4" generated the worst test result, it was reported as final data.**

For Radiated Emissions Below 1GHz test, the following modes were tested:

- Mode 1. Without handheld (For USB Link) (PA966BTG)
- Mode 2. Without handheld (Charging Mode) (PA966BTG)
- Mode 3. With handheld (For USB Link) (PA967BTG)
- Mode 4. With handheld (Charging Mode) (PA967BTG)

**Radiated-Because "mode 1" generated the worst test result, it was reported as final data.**

**2.6. Table for Testing Locations**

Test Site No.	Site Category	Location	FCC Reg. No.	IC File No.	VCCI Reg. No
03CH03-HY	SAC	Hwa Ya	101377	IC 4088	-
CO01-HY	Conduction	Hwa Ya	101377	IC 4088	-
TH01-HY	OVEN Room	Hwa Ya	-	-	-

Open Area Test Site (OATS); Semi Anechoic Chamber (SAC); Fully Anechoic Chamber (FAC).

**2.7. Table for Supporting Units**

Support Unit	Brand	Model	FCC ID
Notebook	DELL	D400	DoC
Mouse	Microsoft	1004	DoC
Modem	ACEEX	DM1414	IFAXDM1414
Printer	EPSON	C61	DoC
Central Office (Remote Workstation)	Easy Switch	PX-4	DoC

**2.8. Table for Parameters of Test Software Setting**

During testing, Channel & Power Controlling Software provided by the customer was used to control the operating channel as well as the output power level. The RF output power selection is for the setting of RF output power expected by the customer and is going to be fixed on the firmware of the final end product.

**Power Parameters of IEEE 802.11b/g**

Test Software Version	SDC TEST		
Frequency	2412 MHz	2437 MHz	2462 MHz
IEEE 802.11b	Default	Default	Default
IEEE 802.11g	Default	Default	Default

**2.9. EUT Operation during Test**

An executive program, EMCTEST.EXE under WIN XP, which generates a complete line of continuously repeating “ H “ pattern was used as the test software.

The program was executed as follows :

Turn on the power of all equipment.

The NB reads the test program from the hard disk drive and runs it.

The NB sends “ H “ messages to the printer, then the printer prints them on the paper.

The NB sends “ H “ messages to the modem.



**2.10. Test Configurations**

**2.10.1. Radiation Emissions Test Configuration**

**For radiated emissions 9kHz~1GHz**

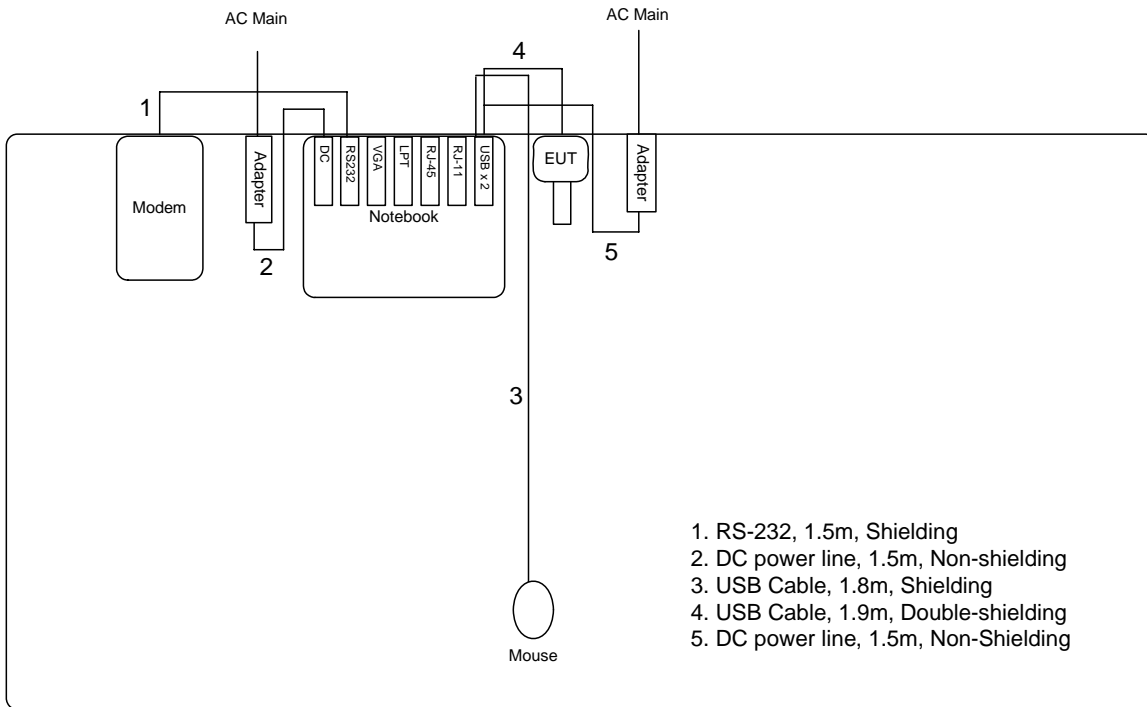

C.O.  
(Remote Workstation)

**For radiated emissions above 1GHz**

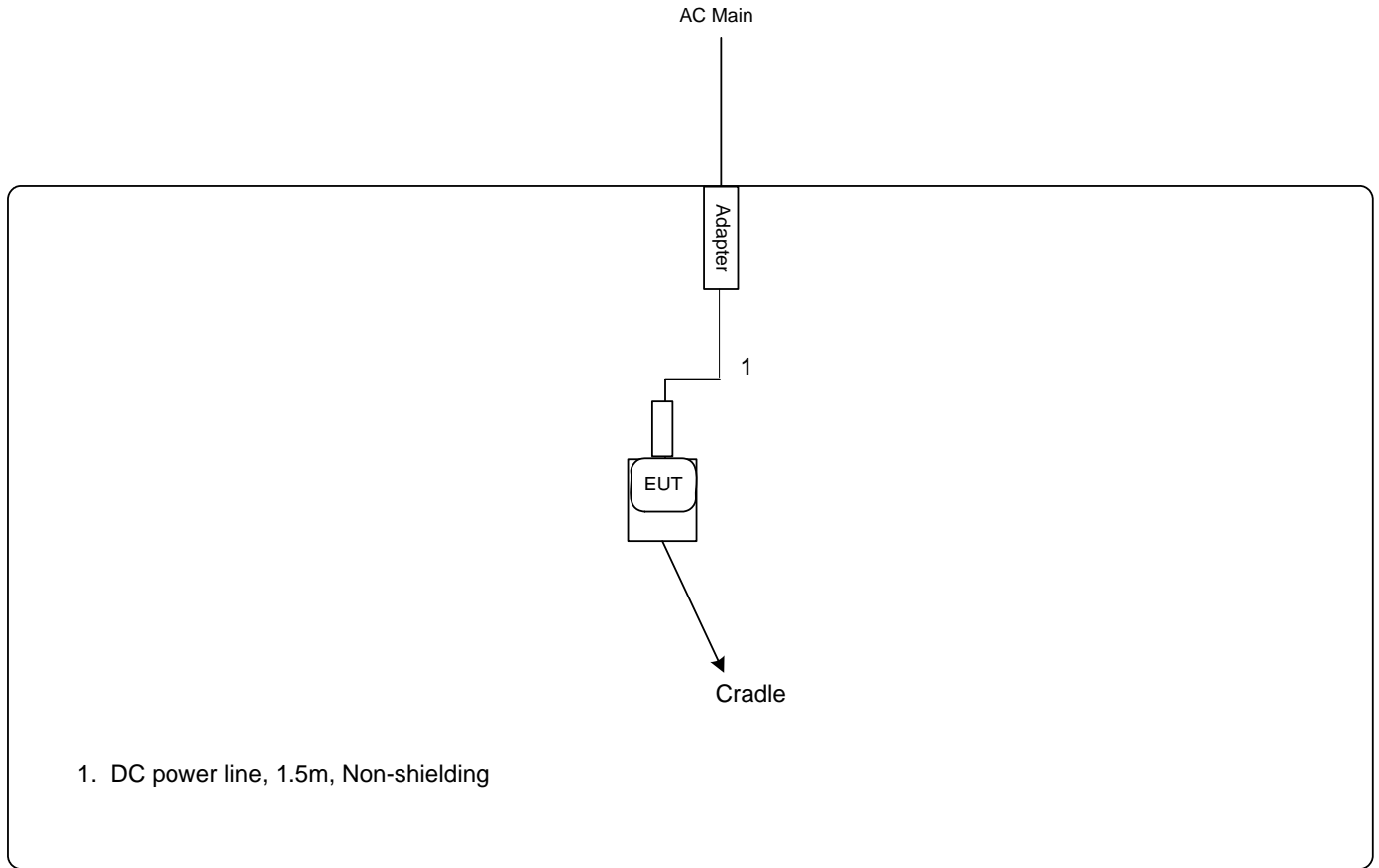

**3. TEST RESULT**

**3.1. AC Power Line Conducted Emissions Measurement**

**3.1.1. Limit**

For this product which is designed to be connected to the AC power line, the radio frequency voltage that is conducted back onto the AC power line on any frequency or frequencies within the band 150 kHz to 30 MHz shall not exceed below limits table.

Frequency (MHz)	QP Limit (dBuV)	AV Limit (dBuV)
0.15~0.5	66~56	56~46
0.5~5	56	46
5~30	60	50

**3.1.2. Measuring Instruments and Setting**

Please refer to section 4 of equipments list in this report. The following table is the setting of the receiver.

Receiver Parameters	Setting
Attenuation	10 dB
Start Frequency	0.15 MHz
Stop Frequency	30 MHz
IF Bandwidth	9 KHz

**3.1.3. Test Procedures**

1. Configure the EUT according to ANSI C63.4. The EUT or host of EUT has to be placed 0.4 meter far from the conducting wall of the shielding room and at least 80 centimeters from any other grounded conducting surface.
2. Connect EUT or host of EUT to the power mains through a line impedance stabilization network (LISN).
3. All the support units are connected to the other LISNs. The LISN should provide 50uH/50ohms coupling impedance.
4. The frequency range from 150 KHz to 30 MHz was searched.
5. Set the test-receiver system to Peak Detect Function and Specified Bandwidth with Maximum Hold Mode.
6. The measurement has to be done between each power line and ground at the power terminal.

3.1.4. Test Setup Layout

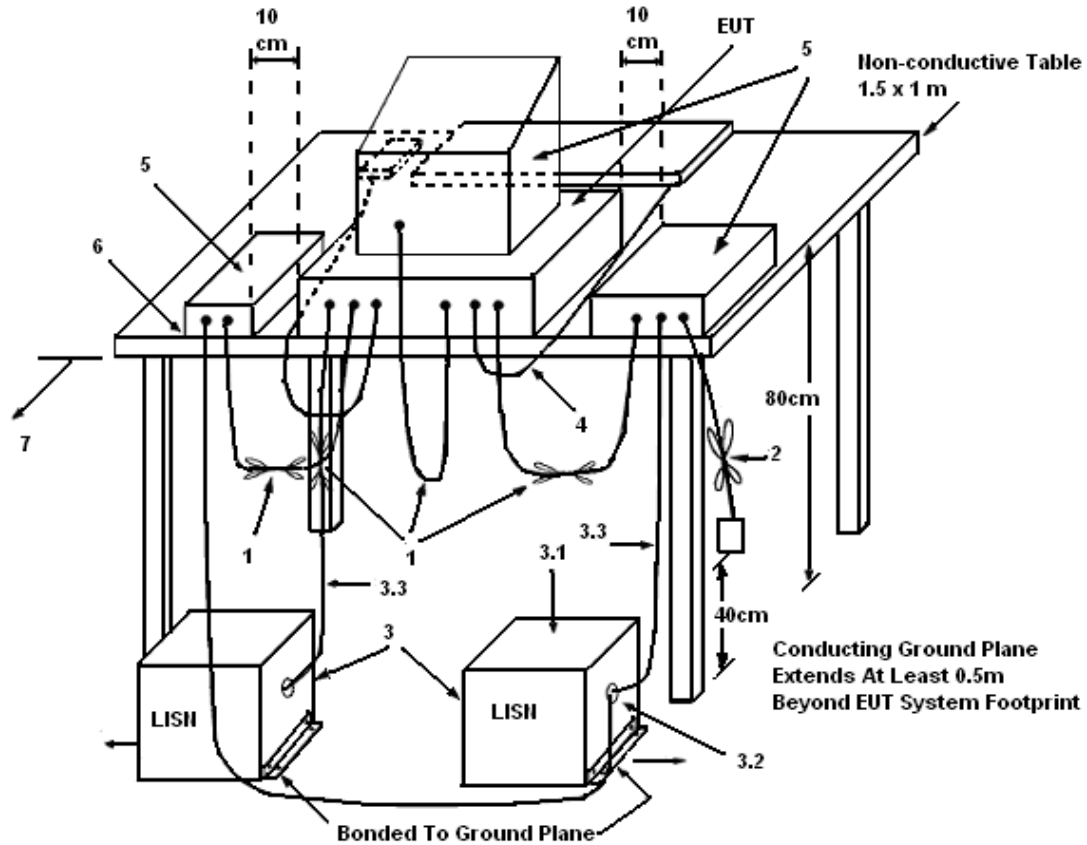

LEGEND:

- (1) Interconnecting cables that hang closer than 40 cm to the ground plane shall be folded back and forth in the center forming a bundle 30 to 40 cm long.
- (2) I/O cables that are not connected to a peripheral shall be bundled in the center. The end of the cable may be terminated, if required, using the correct terminating impedance. The overall length shall not exceed 1 m.
- (3) EUT connected to one LISN. Unused LISN measuring port connectors shall be terminated in 50 Ω. LISN can be placed on top of, or immediately beneath, reference ground plane.
- (3.1) All other equipment powered from additional LISN(s).
- (3.2) Multiple outlet strip can be used for multiple power cords of non-EUT equipment.
- (3.3) LISN at least 80 cm from nearest part of EUT chassis.
- (4) Cables of hand-operated devices, such as keyboards, mice, etc., shall be placed as for normal use.
- (5) Non-EUT components of EUT system being tested.
- (6) Rear of EUT, including peripherals, shall all be aligned and flush with rear of tabletop.
- (7) Rear of tabletop shall be 40 cm removed from a vertical conducting plane that is bonded to the ground plane.

**3.1.5. Test Deviation**

There is no deviation with the original standard.

**3.1.6. EUT Operation during Test**

The EUT was placed on the test table and programmed in normal function.

**3.1.7. Results of AC Power Line Conducted Emissions Measurement**

<b>Temperature</b>	24°C	<b>Humidity</b>	32%
<b>Test Engineer</b>	Ted Chiu	<b>Phase</b>	Line
<b>Configuration</b>	Mode 4		

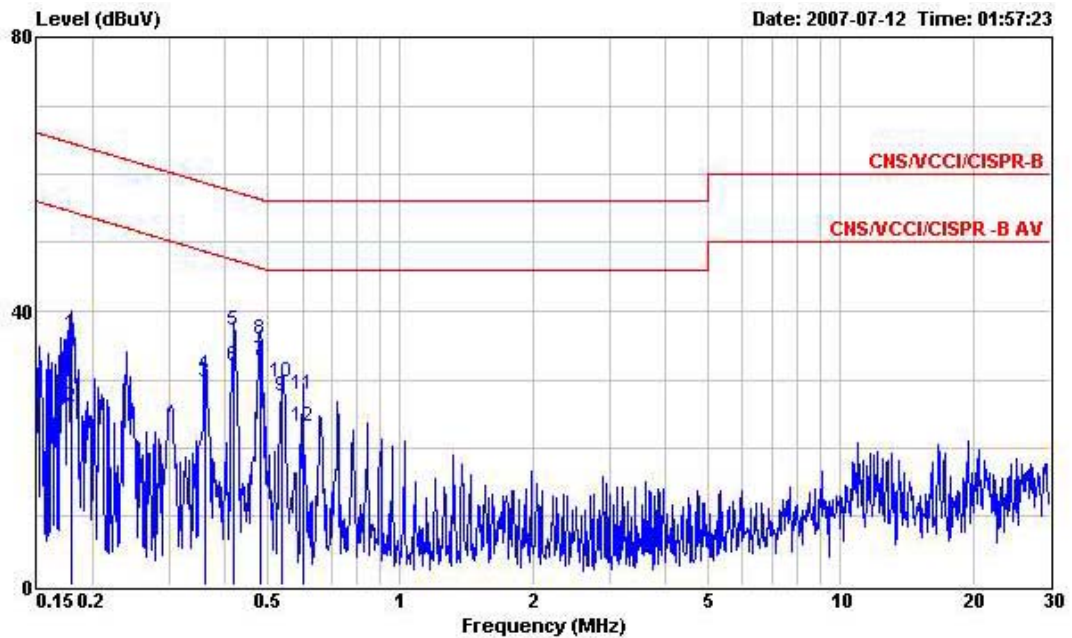

	Freq	Level	Over Limit	Limit Line	Read Level	Probe Factor	Cable Loss	Remark
	MHz	dBuV	dB	dBuV	dBuV	dB	dB	
1	0.179	36.54	-27.99	64.53	36.35	0.10	0.09	QP
2	0.179	26.03	-28.50	54.53	25.84	0.10	0.09	Average
3	0.360	29.60	-19.13	48.73	29.45	0.10	0.05	Average
4	0.360	30.75	-27.98	58.73	30.60	0.10	0.05	QP
5	0.419	37.09	-20.38	57.47	36.94	0.10	0.05	QP
6	0.419	32.08	-15.39	47.47	31.93	0.10	0.05	Average
7	0.481	32.68	-13.64	46.32	32.51	0.10	0.07	Average
8	0.481	35.72	-20.60	56.32	35.55	0.10	0.07	QP
9	0.539	27.47	-18.53	46.00	27.29	0.10	0.08	Average
10	0.539	29.58	-26.42	56.00	29.40	0.10	0.08	QP
11	0.601	27.80	-28.20	56.00	27.60	0.10	0.10	QP
12	0.601	23.24	-22.76	46.00	23.04	0.10	0.10	Average

Temperature	24°C	Humidity	32%
Test Engineer	Ted Chiu	Phase	Neutral
Configuration	Mode 4		

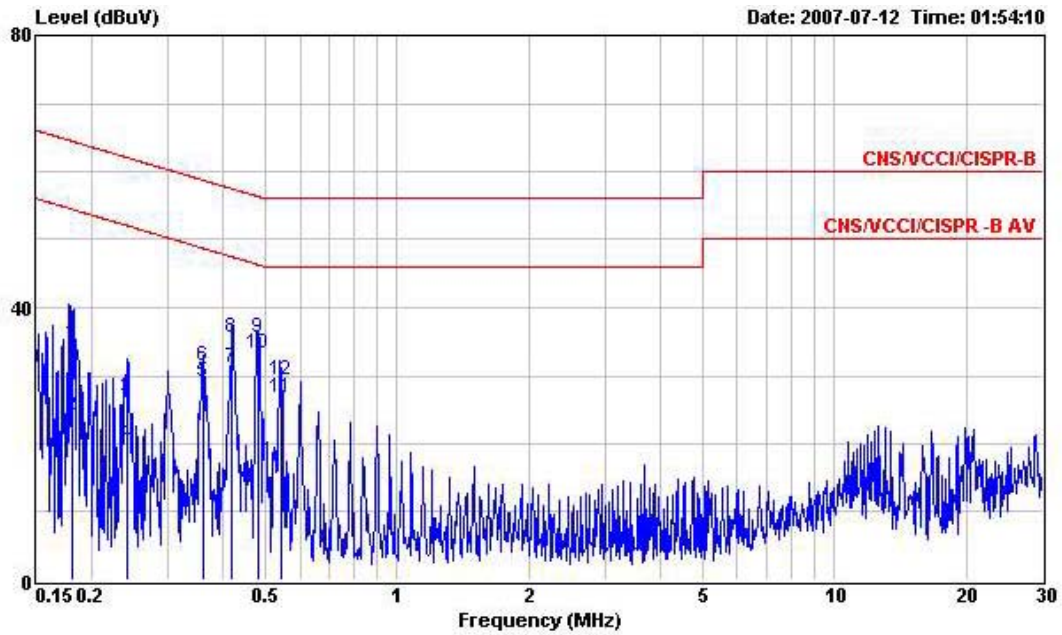

	Freq	Level	Over Limit	Limit Line	Read Level	Probe Factor	Cable Loss	Remark
	MHz	dBuV	dB	dBuV	dBuV	dB	dB	
1	0.181	34.85	-29.60	64.45	34.66	0.10	0.09	QP
2	0.181	24.09	-30.36	54.45	23.90	0.10	0.09	Average
3	0.242	26.83	-35.20	62.03	26.65	0.10	0.08	QP
4	0.242	19.94	-32.09	52.03	19.76	0.10	0.08	Average
5	0.360	29.20	-19.53	48.73	29.05	0.10	0.05	Average
6	0.360	31.30	-27.43	58.73	31.15	0.10	0.05	QP
7	0.419	31.16	-16.31	47.47	31.01	0.10	0.05	Average
8	0.419	35.51	-21.96	57.47	35.36	0.10	0.05	QP
9	0.481	35.66	-20.66	56.32	35.49	0.10	0.07	QP
10	0.481	33.28	-13.04	46.32	33.11	0.10	0.07	Average
11	0.541	26.64	-19.36	46.00	26.46	0.10	0.08	Average
12	0.541	29.40	-26.60	56.00	29.22	0.10	0.08	QP

Note:

Level = Read Level + LISN Factor + Cable Loss.

**3.2. Maximum Peak Output Power Measurement**

**3.2.1. Limit**

For systems using digital modulation in the 2400-2483.5MHz, the limit for peak output power is 30dBm. The limited has to be reduced by the amount in dB that the gain of the antenna exceed 6dBi. In case of point-to-point operation, the limit has to be reduced by 1dB for every 3dB that the directional gain of the antenna exceeds 6dBi.

**3.2.2. Measuring Instruments and Setting**

Please refer to section 4 of equipments list in this report. The following table is the setting of the power meter.

Power Meter Parameter	Setting
Filter No.	Auto
Measurement time	0.135 s ~ 26 s
Used Peak Sensor	NRV-Z32 (model 04)

**3.2.3. Test Procedures**

1. The transmitter output (antenna port) was connected to the power meter.
2. Turn on the EUT and power meter and then record the peak power value.
3. Repeat above procedures on all channels needed to be tested.

**3.2.4. Test Setup Layout**

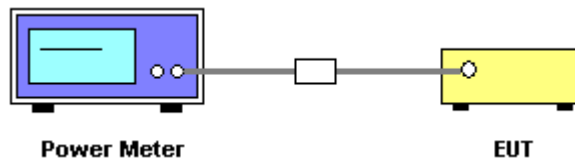

**3.2.5. Test Deviation**

There is no deviation with the original standard.

**3.2.6. EUT Operation during Test**

The EUT was programmed to be in continuously transmitting mode.

**3.2.7. Test Result of Maximum Peak Output Power**

<b>Temperature</b>	26.8°C	<b>Humidity</b>	54%
<b>Test Engineer</b>	Murphy	<b>Configurations</b>	802.11b/g

**Configuration IEEE 802.11b**

<b>Channel</b>	<b>Frequency</b>	<b>Conducted Power (dBm)</b>	<b>Max. Limit (dBm)</b>	<b>Result</b>
1	2412 MHz	18.57	30.00	<b>Complies</b>
6	2437 MHz	18.21	30.00	<b>Complies</b>
11	2462 MHz	18.15	30.00	<b>Complies</b>

**Configuration IEEE 802.11g**

<b>Channel</b>	<b>Frequency</b>	<b>Conducted Power (dBm)</b>	<b>Max. Limit (dBm)</b>	<b>Result</b>
1	2412 MHz	17.52	30.00	<b>Complies</b>
6	2437 MHz	17.88	30.00	<b>Complies</b>
11	2462 MHz	17.81	30.00	<b>Complies</b>



**3.3. Power Spectral Density Measurement**

**3.3.1. Limit**

For digitally modulated systems, the power spectral density conducted from the intentional radiator to the antenna shall not be greater than 8 dBm in any 3 kHz band during any time interval of continuous transmission.

**3.3.2. Measuring Instruments and Setting**

Please refer to section 4 of equipments list in this report. The following table is the setting of the spectrum analyzer.

Spectrum Parameter	Setting
Attenuation	Auto
Span Frequency	1.5MHz
RB	3 kHz
VB	30 kHz
Detector	Peak
Trace	Max Hold
Sweep Time	500s

**3.3.3. Test Procedures**

1. The transmitter output (antenna port) was connected to the spectrum analyser.
2. Set RBW of spectrum analyzer to 3kHz and VBW to 30kHz. Set Detector to Peak, Trace to Max Hold.
3. Mark the frequency with maximum peak power as the center of the display of the spectrum.
4. Set the span to 1.5MHz and the sweep time to 500s and record the maximum peak value.

**3.3.4. Test Setup Layout**

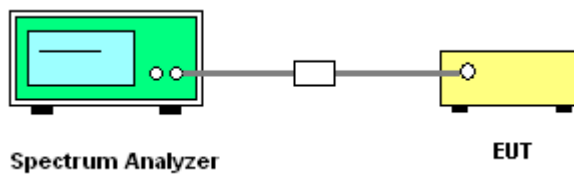

**3.3.5. Test Deviation**

There is no deviation with the original standard.

**3.3.6. EUT Operation during Test**

The EUT was programmed to be in continuously transmitting mode.

**3.3.7. Test Result of Power Spectral Density**

<b>Temperature</b>	26.8°C	<b>Humidity</b>	54%
<b>Test Engineer</b>	Murphy	<b>Configurations</b>	802.11b/g

**Configuration IEEE 802.11b**

Channel	Frequency	Power Density (dBm)	Max. Limit (dBm)	Result
1	2412 MHz	-10.39	8.00	<b>Complies</b>
6	2437 MHz	-8.29	8.00	<b>Complies</b>
11	2462 MHz	-9.46	8.00	<b>Complies</b>

**Configuration IEEE 802.11g**

Channel	Frequency	Power Density (dBm)	Max. Limit (dBm)	Result
1	2412 MHz	-15.16	8.00	<b>Complies</b>
6	2437 MHz	-14.89	8.00	<b>Complies</b>
11	2462 MHz	-15.47	8.00	<b>Complies</b>

Power Density Plot on Configuration IEEE 802.11b / 2412 MHz

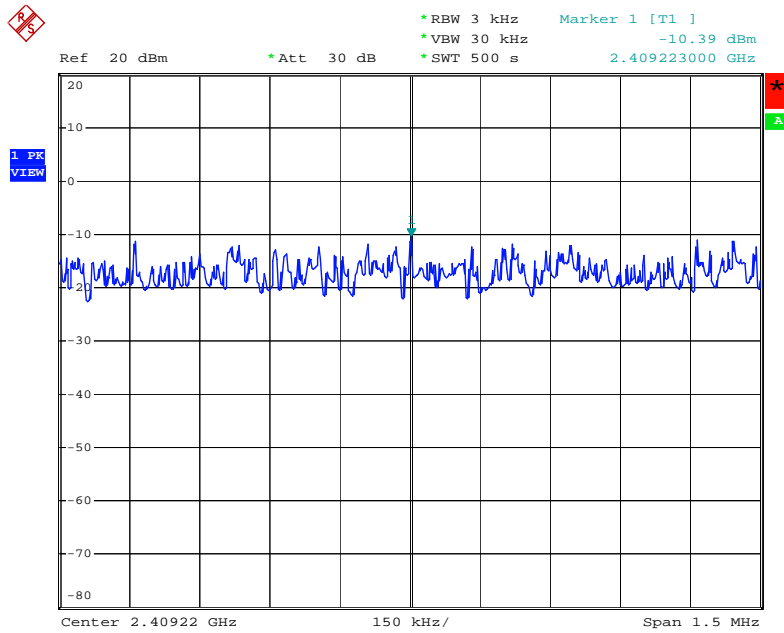

Date: 31.JUL.2007 23:14:09

Power Density Plot on Configuration IEEE 802.11b / 2437 MHz

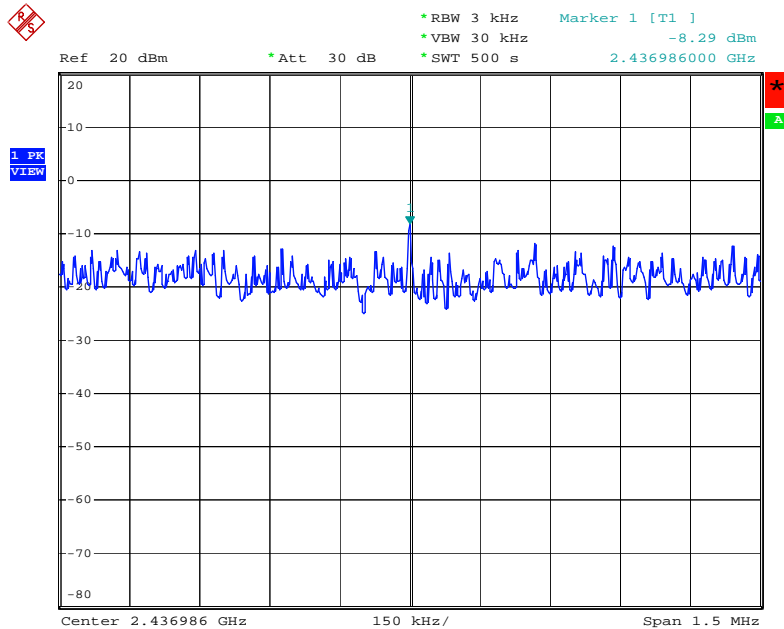

Date: 31.JUL.2007 22:42:49

Power Density Plot on Configuration IEEE 802.11b / 2462 MHz

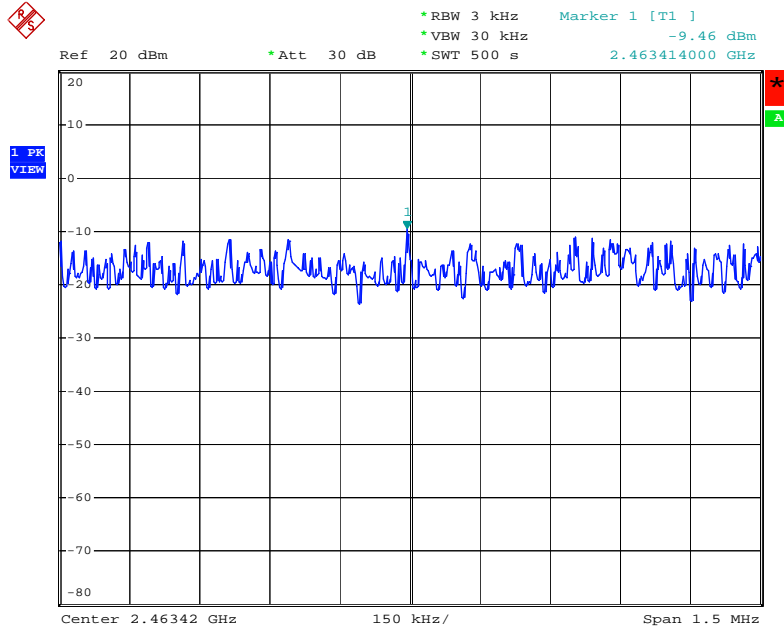

Date: 31.JUL.2007 22:51:10

Power Density Plot on Configuration IEEE 802.11g / 2412 MHz

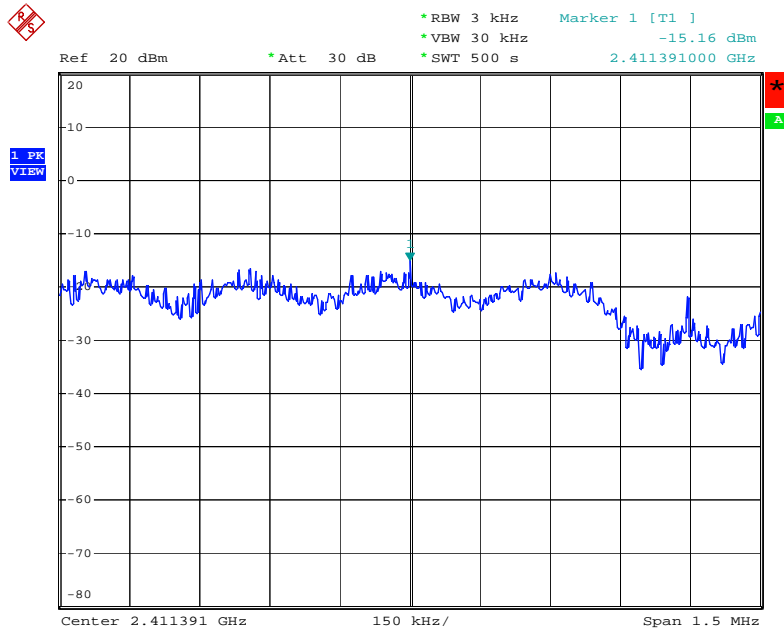

Date: 31.JUL.2007 23:32:46

Power Density Plot on Configuration IEEE 802.11g / 2437 MHz

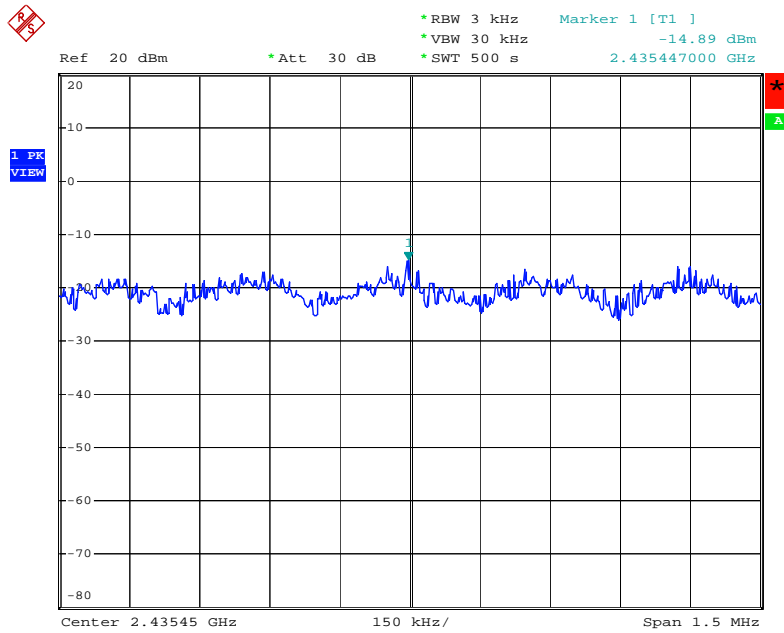

Date: 31.JUL.2007 23:35:29

Power Density Plot on Configuration IEEE 802.11g / 2462 MHz

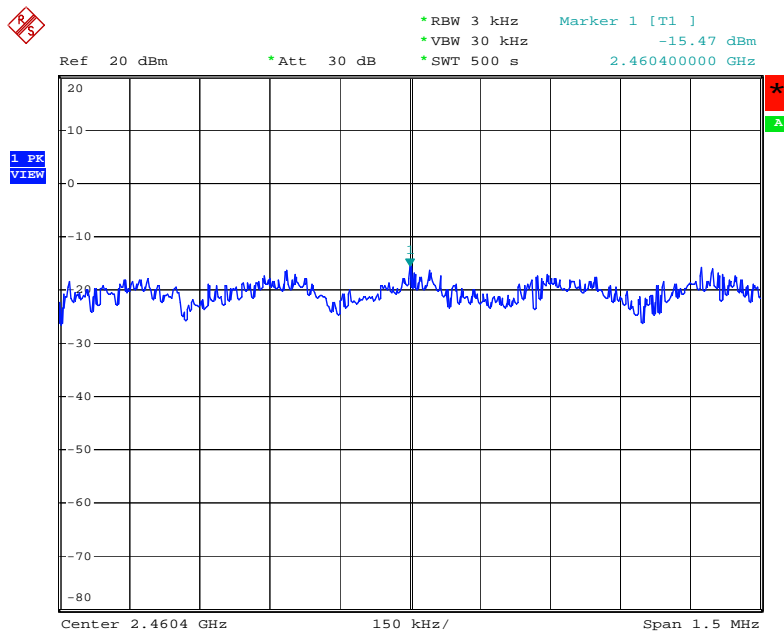

Date: 31.JUL.2007 23:43:48

**3.4. 6dB Spectrum Bandwidth Measurement**

**3.4.1. Limit**

For digital modulation systems, the minimum 6dB bandwidth shall be at least 500 kHz.

**3.4.2. Measuring Instruments and Setting**

Please refer to section 4 of equipments list in this report. The following table is the setting of the spectrum analyzer.

Spectrum Parameters	Setting
Attenuation	Auto
Span Frequency	> 6dB Bandwidth
RB	100 kHz
VB	100 kHz
Detector	Peak
Trace	Max Hold
Sweep Time	Auto

**3.4.3. Test Procedures**

1. The transmitter output (antenna port) was connected to the spectrum analyser in peak hold mode.
2. The resolution bandwidth of 100 kHz and the video bandwidth of 100 kHz were used.
3. Measured the spectrum width with power higher than 6dB below carrier.

**3.4.4. Test Setup Layout**

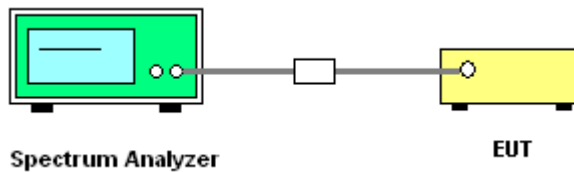

**3.4.5. Test Deviation**

There is no deviation with the original standard.

**3.4.6. EUT Operation during Test**

The EUT was programmed to be in continuously transmitting mode.

**3.4.7. Test Result of 6dB Spectrum Bandwidth**

<b>Temperature</b>	26.8°C	<b>Humidity</b>	54%
<b>Test Engineer</b>	Murphy	<b>Configurations</b>	802.11b/g

**Configuration IEEE 802.11b**

Channel	Frequency	6dB Bandwidth (MHz)	99% Occupied Bandwidth (MHz)	Min. Limit (kHz)	Test Result
1	2412 MHz	10.64	12.52	500	<b>Complies</b>
6	2437 MHz	10.60	12.56	500	<b>Complies</b>
11	2462 MHz	10.60	12.56	500	<b>Complies</b>

**Configuration IEEE 802.11g**

Channel	Frequency	6dB Bandwidth (MHz)	99% Occupied Bandwidth (MHz)	Min. Limit (kHz)	Test Result
1	2412 MHz	16.36	16.44	500	<b>Complies</b>
6	2437 MHz	16.36	16.44	500	<b>Complies</b>
11	2462 MHz	16.36	16.44	500	<b>Complies</b>

6 dB Bandwidth Plot on Configuration IEEE 802.11b / 2412 MHz

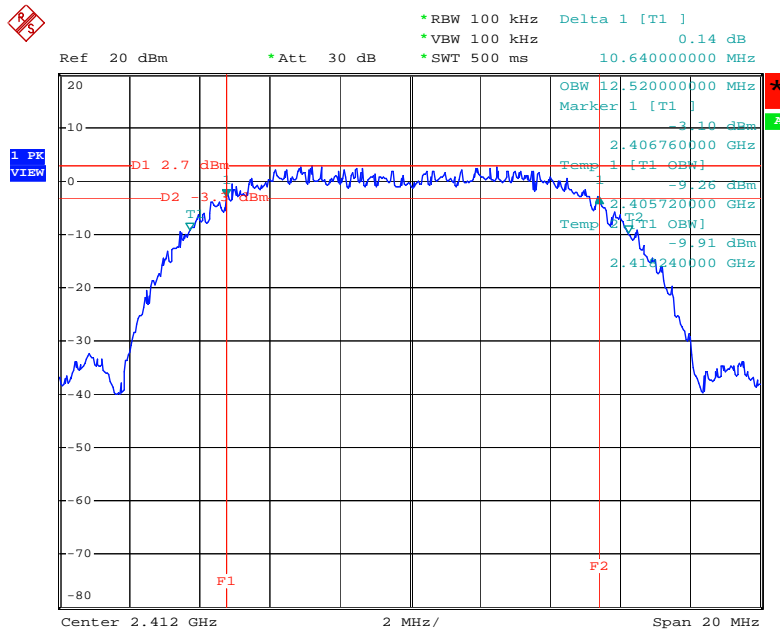

Date: 31.JUL.2007 23:11:29

6 dB Bandwidth Plot on Configuration IEEE 802.11b / 2437 MHz

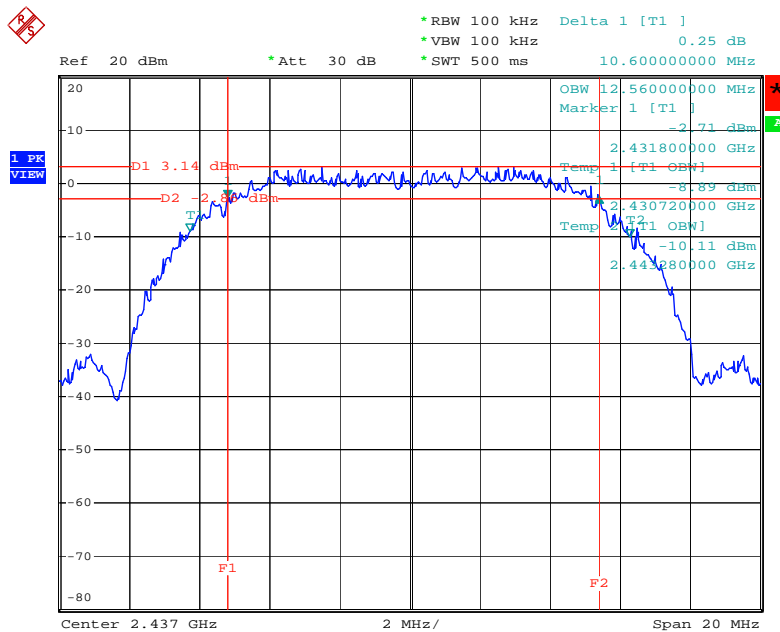

Date: 31.JUL.2007 22:30:25



6 dB Bandwidth Plot on Configuration IEEE 802.11b / 2462 MHz

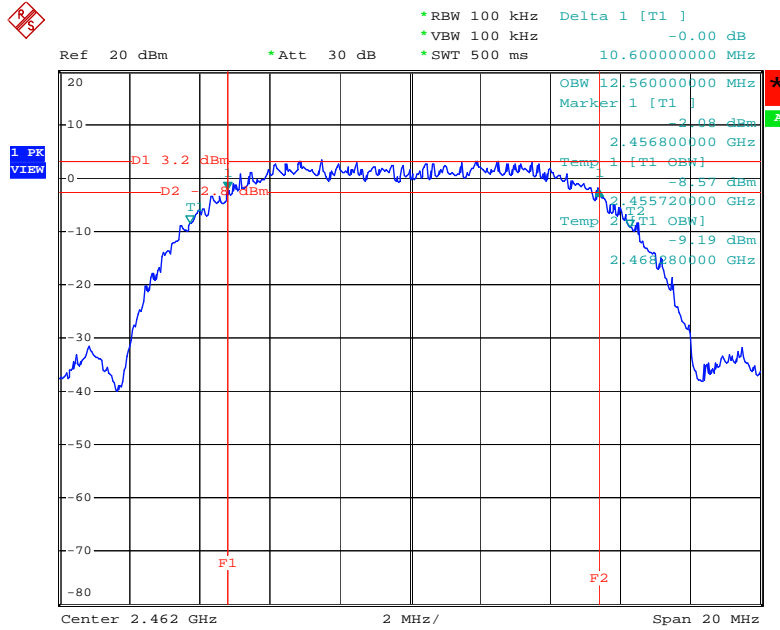

Date: 31.JUL.2007 22:55:51

6 dB Bandwidth Plot on Configuration IEEE 802.11g / 2412 MHz

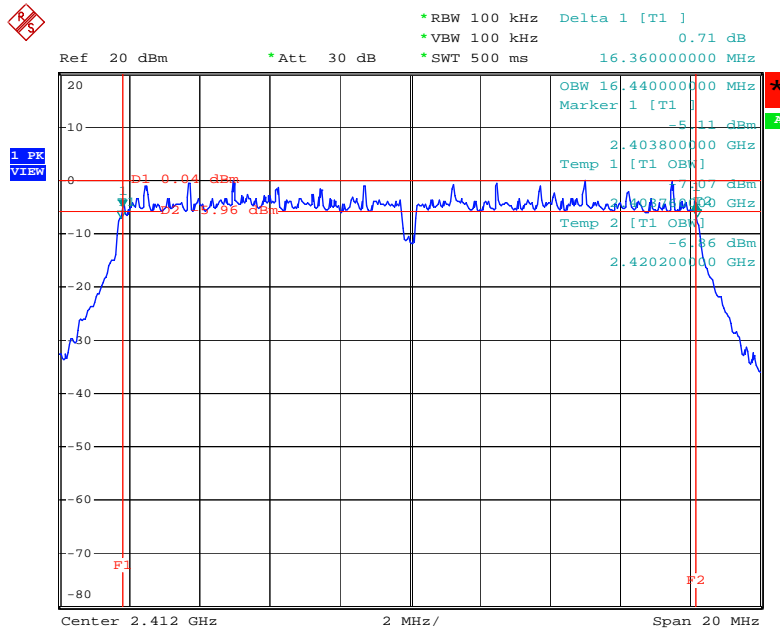

Date: 31.JUL.2007 23:26:10

6 dB Bandwidth Plot on Configuration IEEE 802.11g / 2437 MHz

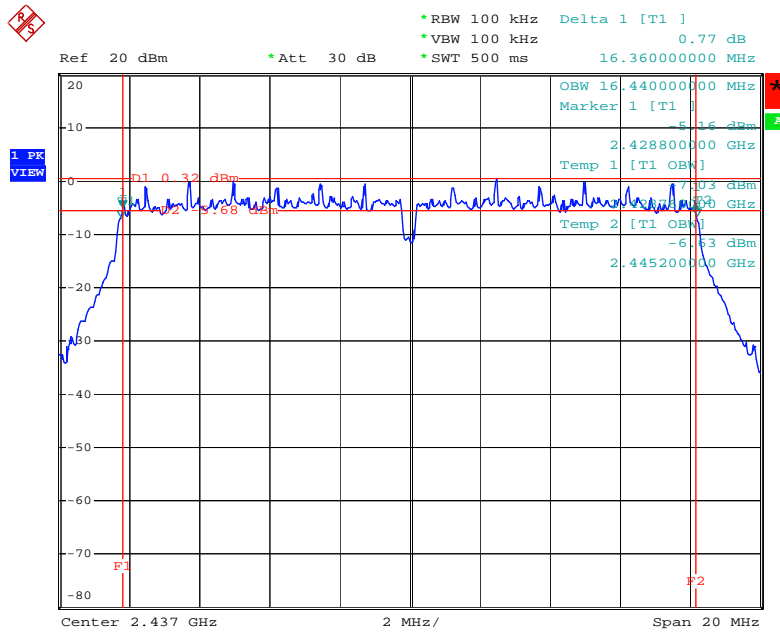

Date: 31.JUL.2007 23:37:31

6 dB Bandwidth Plot on Configuration IEEE 802.11g / 2462 MHz

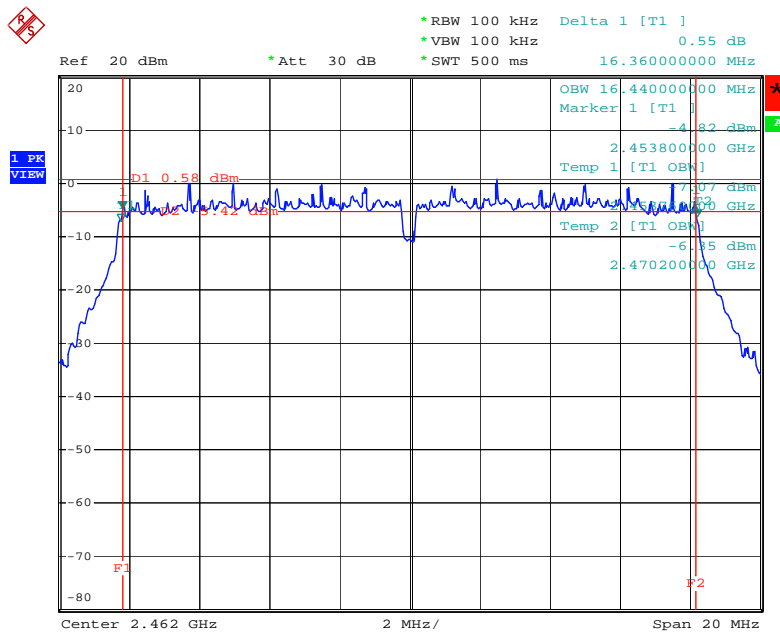

Date: 31.JUL.2007 23:40:27

**3.5. Radiated Emissions Measurement**

**3.5.1. Limit**

20dBc in any 100 kHz bandwidth outside the operating frequency band. In case the emission fall within the restricted band specified on 15.205(a), then the 15.209(a) limit in the table below has to be followed.

<b>Frequencies (MHz)</b>	<b>Field Strength (micorvolts/meter)</b>	<b>Measurement Distance (meters)</b>
0.009~0.490	2400/F(KHz)	300
0.490~1.705	24000/F(KHz)	30
1.705~30.0	30	30
30~88	100	3
88~216	150	3
216~960	200	3
Above 960	500	3

**3.5.2. Measuring Instruments and Setting**

Please refer to section 4 of equipments list in this report. The following table is the setting of spectrum analyzer and receiver.

<b>Spectrum Parameter</b>	<b>Setting</b>
Attenuation	Auto
Start Frequency	1000 MHz
Stop Frequency	10th carrier harmonic
RB / VB (Emission in restricted band)	1MHz / 1MHz for Peak, 1 MHz / 10Hz for Average
RB / VB (Emission in non-restricted band)	100KHz / 100KHz for peak

<b>Receiver Parameter</b>	<b>Setting</b>
Attenuation	Auto
Start ~ Stop Frequency	9kHz~150kHz / RB 200Hz for QP
Start ~ Stop Frequency	150kHz~30MHz / RB 9kHz for QP
Start ~ Stop Frequency	30MHz~1000MHz / RB 120kHz for QP

**3.5.3. Test Procedures**

1. Configure the EUT according to ANSI C63.4. The EUT was placed on the top of the turntable 0.8 meter above ground. The phase center of the receiving antenna mounted on the top of a height-variable antenna tower was placed 3 meters far away from the turntable.
2. Power on the EUT and all the supporting units. The turntable was rotated by 360 degrees to determine the position of the highest radiation.
3. The height of the broadband receiving antenna was varied between one meter and four meters above ground to find the maximum emissions field strength of both horizontal and vertical polarization.
4. For each suspected emissions, the antenna tower was scan (from 1 M to 4 M) and then the turntable was rotated (from 0 degree to 360 degrees) to find the maximum reading.
5. Set the test-receiver system to Peak or CISPR quasi-peak Detect Function with specified bandwidth under Maximum Hold Mode.
6. For emissions above 1GHz, use 1MHz VBW and RBW for peak reading. Then 1MHz RBW and 10Hz VBW for average reading in spectrum analyzer.
7. When the radiated emissions limits are expressed in terms of the average value of the emissions, and pulsed operation is employed, the measurement field strength shall be determined by averaging over one complete pulse train, including blanking intervals, as long as the pulse train does not exceed 0.1 seconds. As an alternative (provided the transmitter operates for longer than 0.1 seconds) or in cases where the pulse train exceeds 0.1 seconds, the measured field strength shall be determined from the average absolute voltage during a 0.1 second interval during which the field strength is at its maximum value.
8. If the emissions level of the EUT in peak mode was 3 dB lower than the average limit specified, then testing will be stopped and peak values of EUT will be reported, otherwise, the emissions which do not have 3 dB margin will be repeated one by one using the quasi-peak method for below 1GHz.
9. For testing above 1GHz, the emissions level of the EUT in peak mode was lower than average limit (that means the emissions level in peak mode also complies with the limit in average mode), then testing will be stopped and peak values of EUT will be reported, otherwise, the emissions will be measured in average mode again and reported.
10. In case the emission is lower than 30MHz, loop antenna has to be used for measurement and the recorded data should be QP measured by receiver. High – Low scan is not required in this case.

**3.5.4. Test Setup Layout**

For radiated emissions below 30MHz

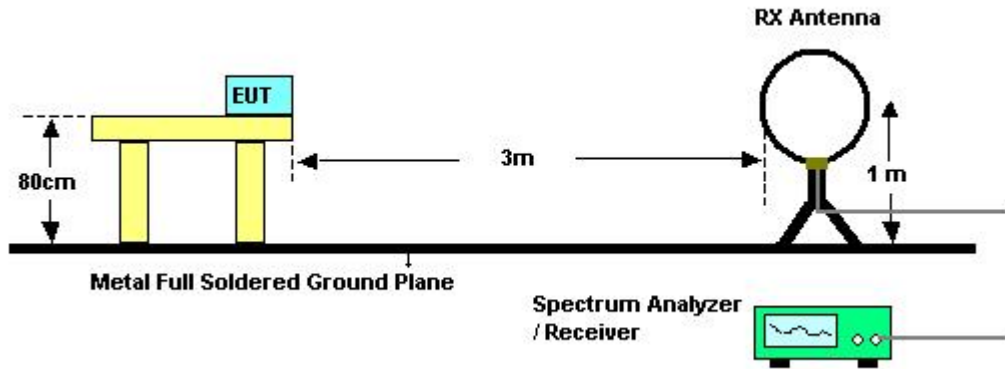

For radiated emissions above 30MHz

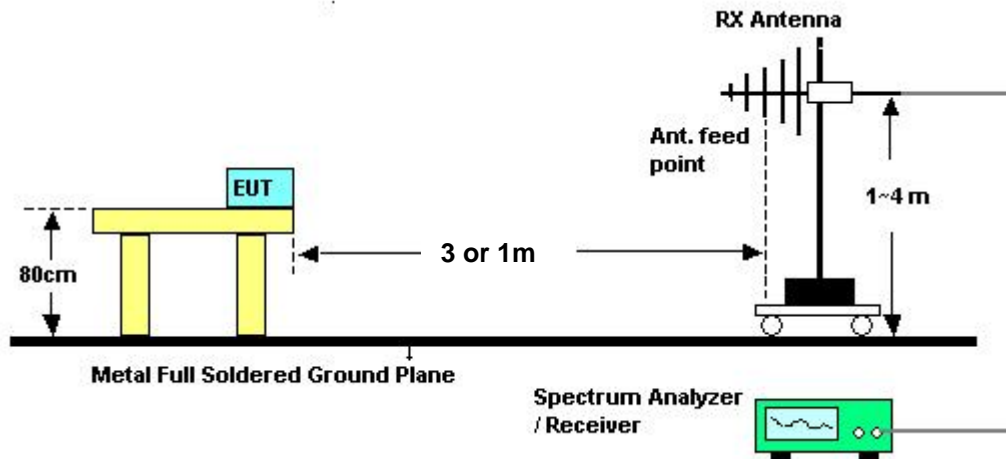

Above 10 GHz shall be extrapolated to the specified distance using an extrapolation factor of 20 dB/decade from 3m to 1m.

Distance extrapolation factor =  $20 \log (\text{specific distance [3m]} / \text{test distance [1m]})$  (dB);

Limit line = specific limits (dBuV) + distance extrapolation factor [9.54 dB].

**3.5.5. Test Deviation**

There is no deviation with the original standard.

**3.5.6. EUT Operation during Test**

The EUT was programmed to be in continuously transmitting mode.

**3.5.7. Results of Radiated Emissions (9kHz~30MHz)**

<b>Temperature</b>	25°C	<b>Humidity</b>	54%
<b>Test Engineer</b>	Duncan		

<b>Freq. (MHz)</b>	<b>Level (dBuV)</b>	<b>Over Limit (dB)</b>	<b>Limit Line (dBuV)</b>	<b>Remark</b>
-	-	-	-	See Note

Note:

The amplitude of spurious emissions that are attenuated by more than 20 dB below the permissible value has no need to be reported.

Distance extrapolation factor =  $40 \log(\text{specific distance} / \text{test distance})$  (dB);

Limit line = specific limits (dBuV) + distance extrapolation factor.

3.5.8. Results of Radiated Emissions (30MHz~1GHz)

Temperature	25°C	Humidity	54%
Test Engineer	Duncan	Configurations	Mode 1

Horizontal

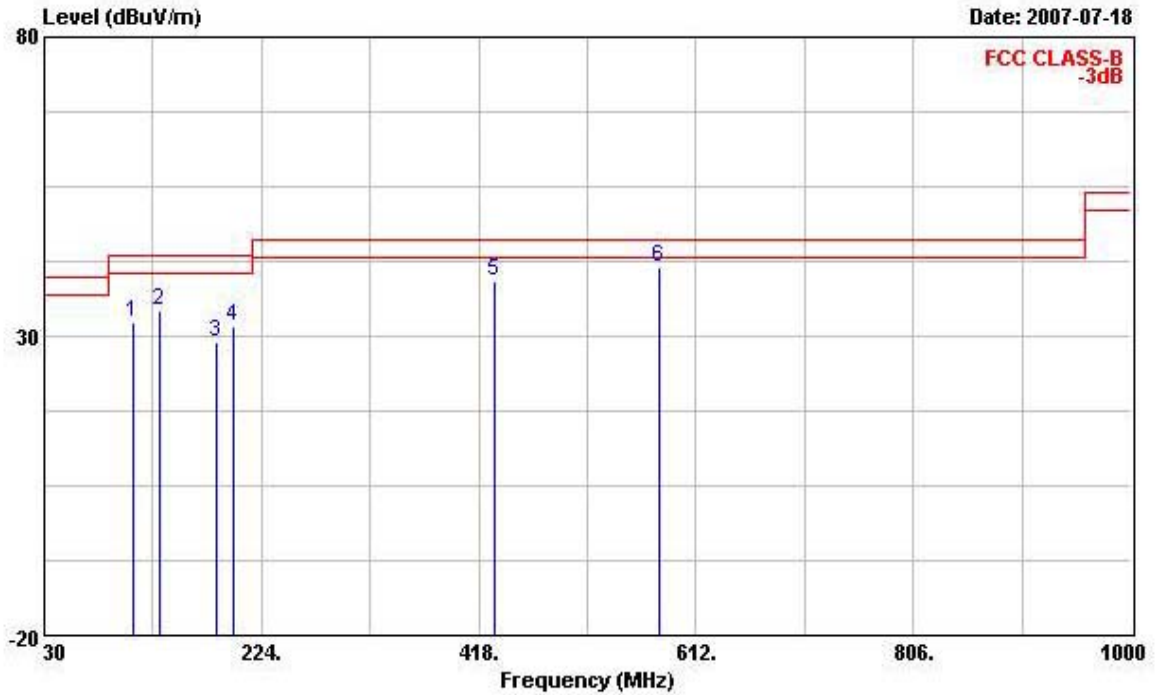

	Freq	Level	Read Level	Over Limit	Limit	Antenna Line Factor	Cable Loss	Preamp Factor	Remark
	MHz	dBUV/m	dBUV	dB	dBUV/m	dB/m	dB	dB	
1	109.540	32.35	45.03	-11.15	43.50	12.40	2.72	27.80	Peak
2	132.820	34.13	47.00	-9.37	43.50	12.10	2.96	27.93	Peak
3	184.230	29.12	44.81	-14.38	43.50	9.10	3.07	27.87	Peak
4	198.780	31.51	46.46	-11.99	43.50	9.61	3.54	28.09	Peak
5	432.550	39.11	46.53	-6.89	46.00	17.08	4.42	28.92	QP
6	579.990	41.54	47.02	-4.46	46.00	19.30	4.79	29.57	Peak

Vertical

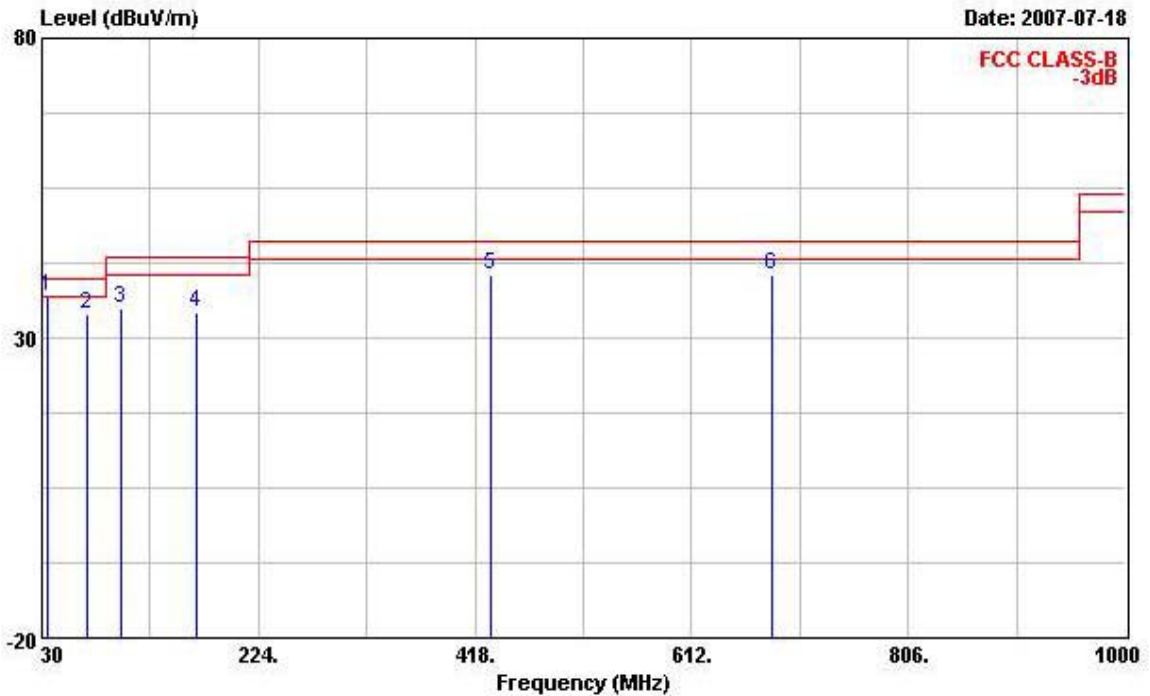

	Freq	Level	Read Level	Over Limit	Limit	Antenna Line Factor	Cable Loss	Preamp Factor	Remark
	MHz	dBuV/m	dBuV	dB	dBuV/m	dB/m	dB	dB	
1	35.820	36.82	47.08	-3.18	40.00	14.94	2.50	27.70	QP
2	70.740	33.98	52.18	-6.02	40.00	6.10	3.42	27.73	Peak
3	101.780	34.93	48.40	-8.57	43.50	11.44	2.83	27.74	Peak
4	167.740	34.21	48.90	-9.29	43.50	9.81	3.36	27.86	Peak
5	431.580	40.50	47.91	-5.50	46.00	17.09	4.41	28.91	Peak
6	684.750	40.41	45.07	-5.59	46.00	19.86	5.24	29.77	Peak

Note:

The amplitude of spurious emissions that are attenuated by more than 20dB below the permissible value has no need to be reported.

Emission level (dBuV/m) = 20 log Emission level (uV/m).

Corrected Reading: Antenna Factor + Cable Loss + Read Level - Preamp Factor = Level.



3.5.9. Results for Radiated Emissions (1GHz~10<sup>th</sup> Harmonic)

Temperature	25°C	Humidity	54%
Test Engineer	Duncan	Configurations	802.11b CH 1

Horizontal

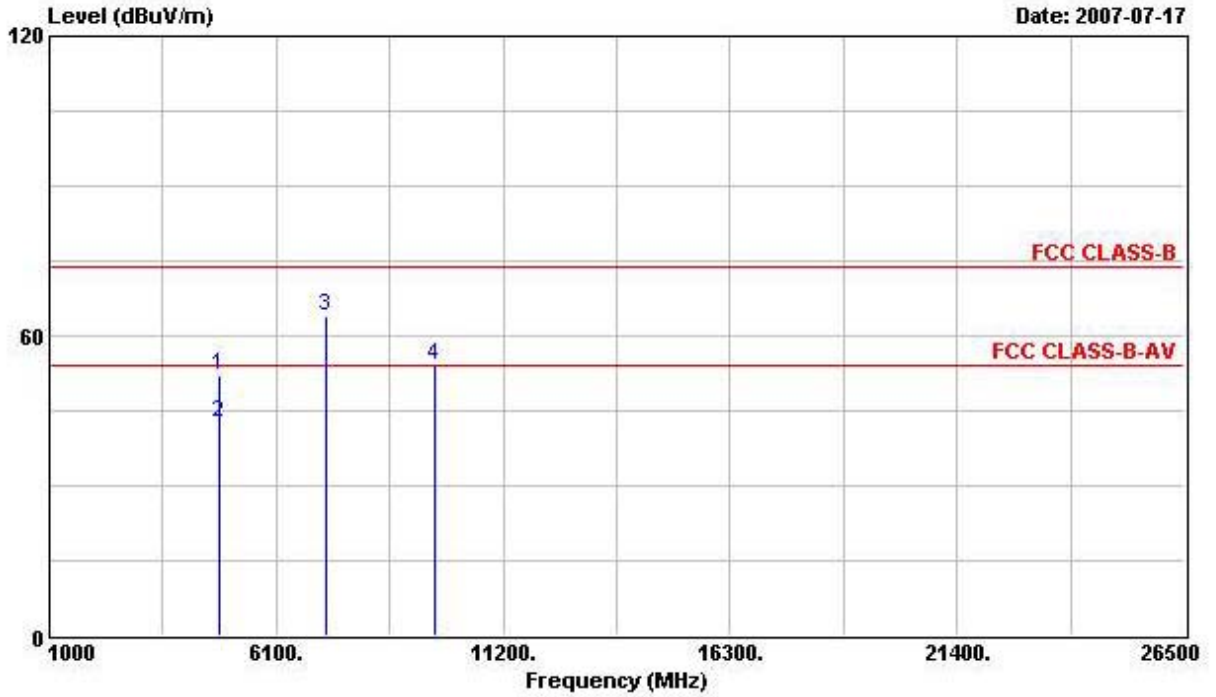

	Freq	Level	Read	Over	Limit	Antenna	Cable	Preamp	Remark
	MHz	dBuV/m	Level	Limit	Line	Factor	Loss	Factor	
			dBuV	dB	dBuV/m	dB/m	dB	dB	
1	4822.000	52.11	47.44	-21.89	74.00	33.06	4.35	32.74	Peak
2	4822.000	42.60	37.93	-11.40	54.00	33.06	4.35	32.74	Average
3	7236.000	64.02	56.01			35.78	5.18	32.95	PEAK
4	9648.000	54.00	42.52			38.41	6.48	33.40	PEAK

Note: Items 3 and 4 are on un-restricted band, so the limit is -20dBc for the field strength of the fundamental emissions (see section 3.6.7).

Vertical

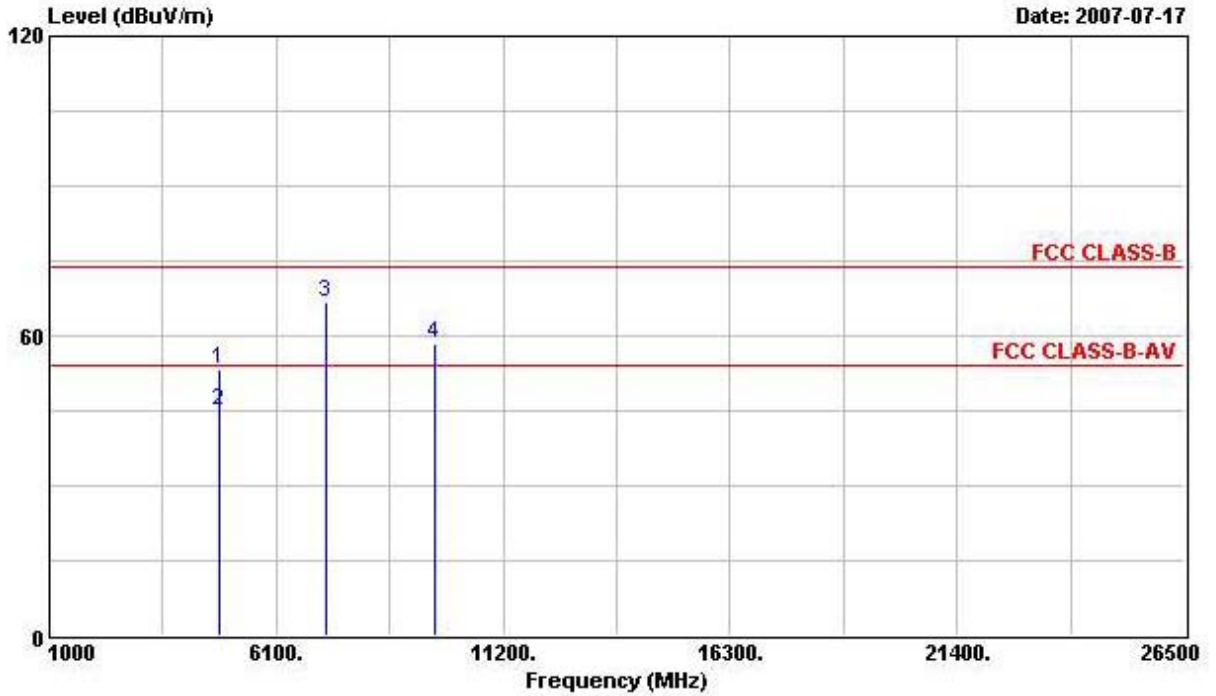

	Freq	Level	Read Level	Over Limit	Limit	Antenna Line Factor	Cable Loss	Preamp Factor	Remark
	MHz	dBuV/m	dBuV	dB	dBuV/m	dB/m	dB	dB	
1	4824.000	53.35	48.68	-20.65	74.00	33.06	4.35	32.74	PEAK
2	4824.000	44.94	40.27	-9.06	54.00	33.06	4.35	32.74	Average
3	7236.000	66.59	58.58			35.78	5.18	32.95	PEAK
4	9648.000	58.36	46.87			38.41	6.48	33.40	PEAK

Note: Items 3 and 4 are on un-restricted band, so the limit is -20dBc for the field strength of the fundamental emissions (see section 3.6.7).

Temperature	25°C	Humidity	54%
Test Engineer	Duncan	Configurations	802.11b CH 6

Horizontal

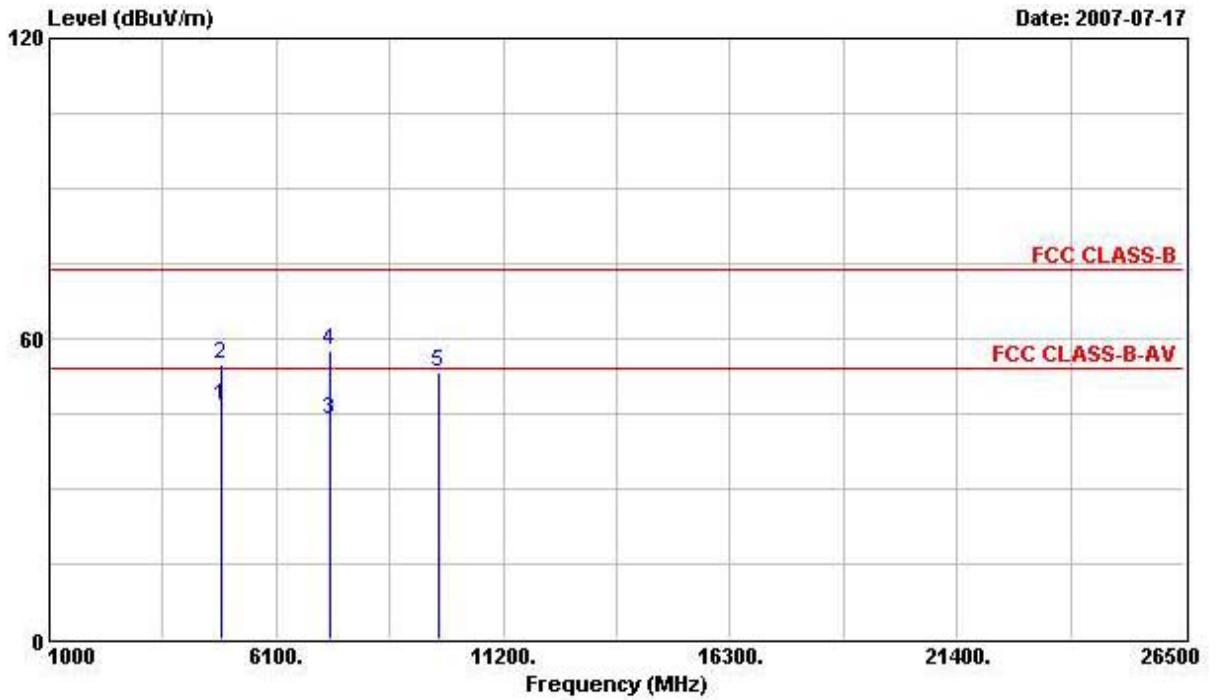

	Freq	Level	Read Level	Over Limit	Limit	Antenna Line Factor	Cable Loss	Preamp Factor	Remark
	MHz	dBuV/m	dBuV	dB	dBuV/m	dB/m	dB	dB	
1	4876.000	46.59	41.79	-7.41	54.00	33.16	4.36	32.73	Average
2	4876.000	54.88	50.08	-19.12	74.00	33.16	4.36	32.73	PEAK
3	7308.000	43.92	35.64	-10.08	54.00	35.94	5.30	32.96	Average
4	7308.000	57.72	49.44	-16.28	74.00	35.94	5.30	32.96	PEAK
5	9748.000	53.28	41.47			38.62	6.58	33.40	PEAK

Note: Items 5 is on un-restricted band, so the limit is -20dBc for the field strength of the fundamental emissions (see section 3.6.7).

Vertical

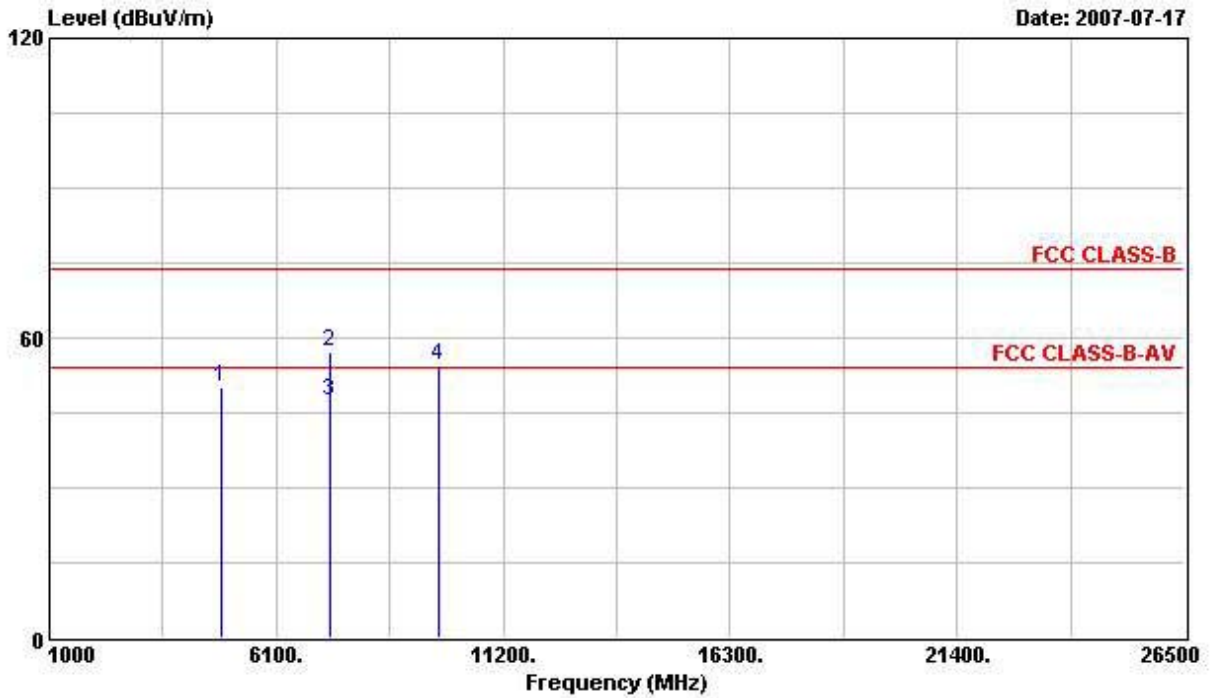

	Freq	Level	Read Level	Over Limit	Limit	Antenna Line Factor	Cable Loss	Preamp Factor	Remark
	MHz	dBUV/m	dBuV	dB	dBUV/m	dB/m	dB	dB	
1	4876.000	49.99	45.19	-4.01	54.00	33.16	4.36	32.73	Average
2	7308.000	57.12	48.83	-16.88	74.00	35.94	5.30	32.96	PEAK
3	7308.000	47.52	39.24	-6.48	54.00	35.94	5.30	32.96	Average
4	9748.000	54.28	42.48			38.62	6.58	33.40	PEAK

Note: Items 4 is on un-restricted band, so the limit is -20dBc for the field strength of the fundamental emissions (see section 3.6.7).

Temperature	25°C	Humidity	54%
Test Engineer	Duncan	Configurations	802.11b CH 11

Horizontal

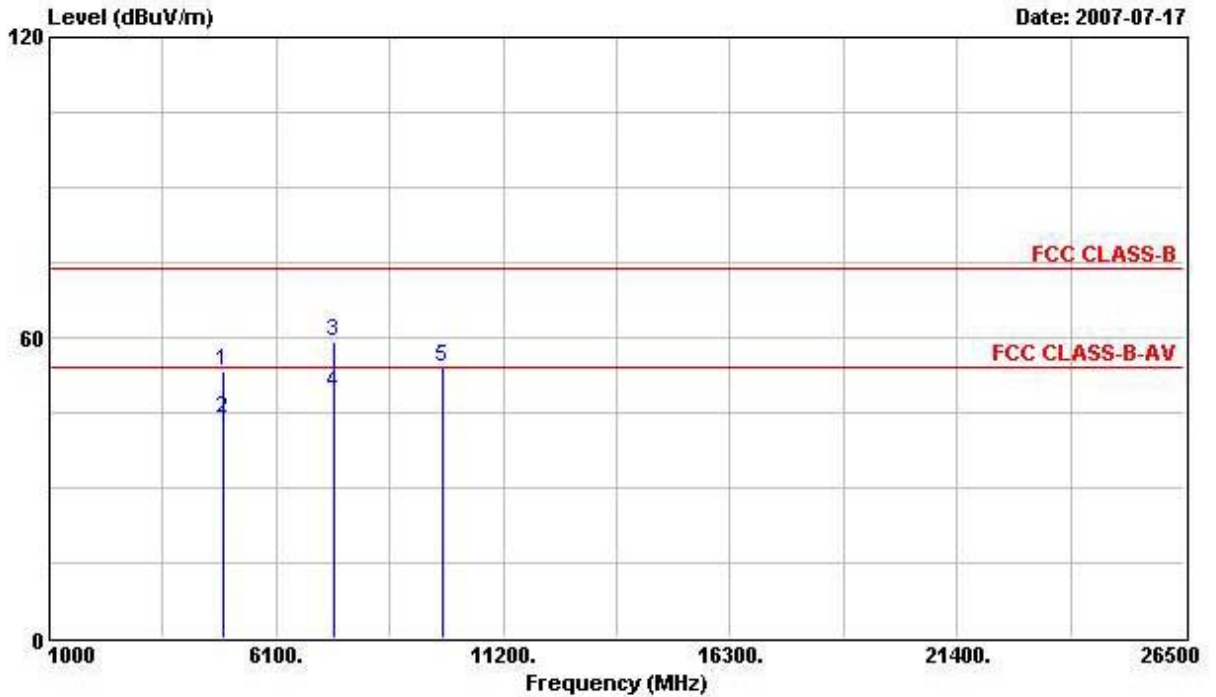

	Freq	Level	Read Level	Over Limit	Limit	Antenna Line Factor	Cable Loss	Preamp Factor	Remark
	MHz	dBuV/m	dBuV	dB	dBuV/m	dB/m	dB	dB	
1	4924.000	53.32	48.38	-20.68	74.00	33.26	4.40	32.72	PEAK
2	4924.000	43.73	38.79	-10.27	54.00	33.26	4.40	32.72	Average
3	7384.000	59.33	50.74	-14.67	74.00	36.15	5.41	32.98	PEAK
4	7384.000	48.83	40.24	-5.17	54.00	36.15	5.41	32.98	Average
5	9848.000	54.27	42.14			38.79	6.74	33.40	PEAK

Note: Items 5 is on un-restricted band, so the limit is -20dBc for the field strength of the fundamental emissions (see section 3.6.7).

Vertical

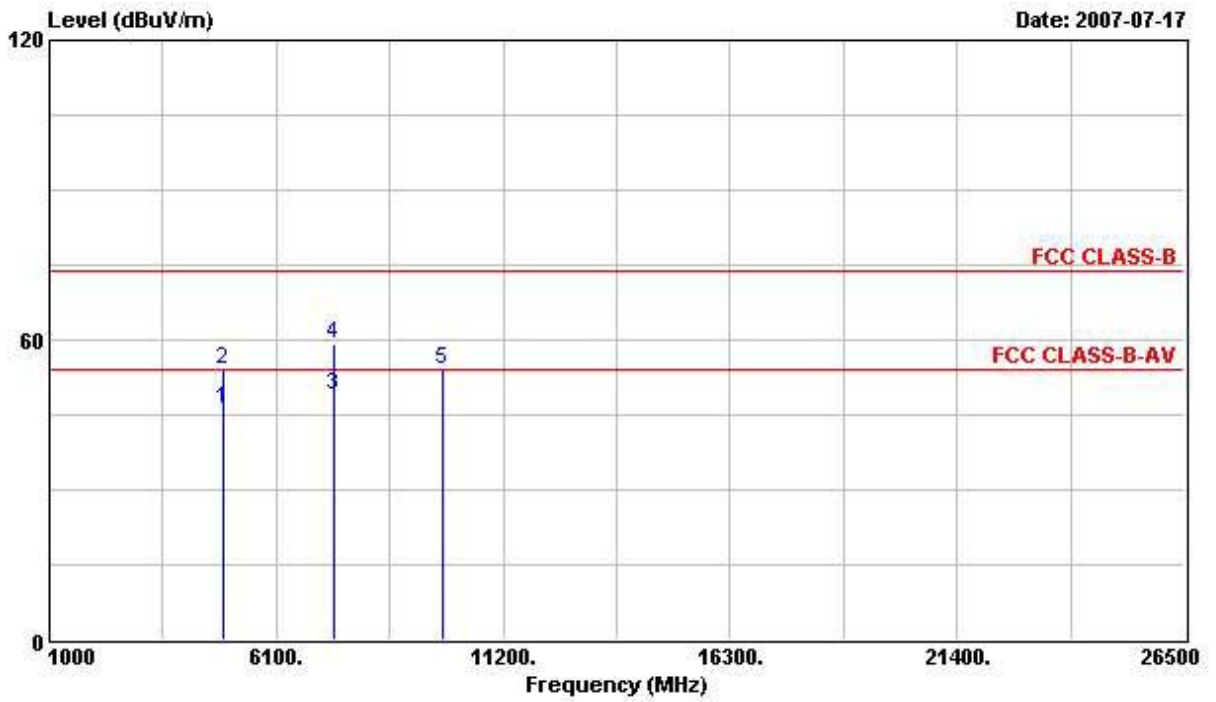

	Freq	Level	Read Level	Over Limit	Limit	Antenna Line Factor	Cable Loss	Preamp Factor	Remark
	MHz	dBuV/m	dBuV	dB	dBuV/m	dB/m	dB	dB	
1	4924.000	46.15	41.21	-7.85	54.00	33.26	4.40	32.72	Average
2	4924.000	54.26	49.32	-19.74	74.00	33.26	4.40	32.72	PEAK
3	7388.000	48.82	40.23	-5.18	54.00	36.15	5.41	32.98	Average
4	7388.000	59.37	50.78	-14.63	74.00	36.15	5.41	32.98	PEAK
5	9848.000	54.24	42.10			38.79	6.74	33.40	PEAK

Note: Items 5 is on un-restricted band, so the limit is -20dBc for the field strength of the fundamental emissions (see section 3.6.7).

Temperature	25°C	Humidity	54%
Test Engineer	Duncan	Configurations	802.11g CH 1

Horizontal

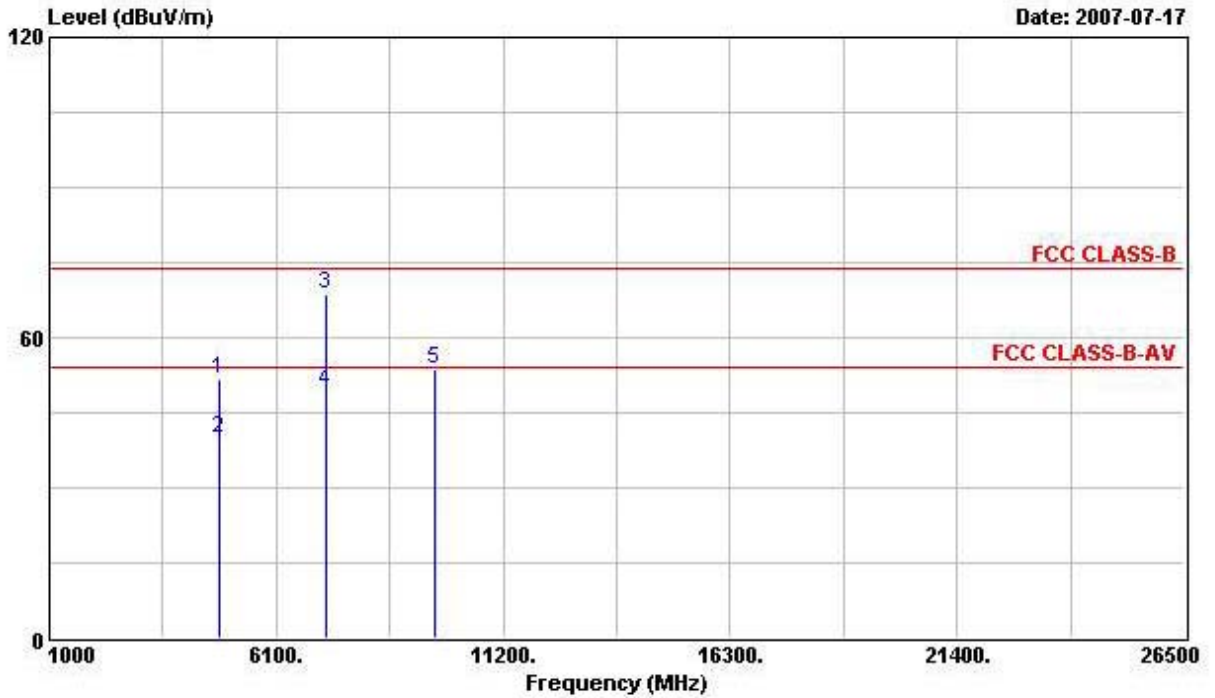

	Freq	Level	Read Level	Over Limit	Limit	Antenna Line Factor	Cable Loss	Preamp Factor	Remark
	MHz	dBUV/m	dBuV	dB	dBUV/m	dB/m	dB	dB	
1	4824.000	51.90	47.23	-22.10	74.00	33.06	4.35	32.74	PEAK
2	4824.000	39.94	35.27	-14.06	54.00	33.06	4.35	32.74	Average
3	7240.000	68.77	60.76	-5.23	74.00	35.78	5.18	32.95	PEAK
4	7240.000	49.52	41.51	-4.48	54.00	35.78	5.18	32.95	Average
5	9644.000	53.69	42.24			38.38	6.48	33.40	PEAK

Note: Items 5 is on un-restricted band, so the limit is -20dBc for the field strength of the fundamental emissions (see section 3.6.7).

Vertical

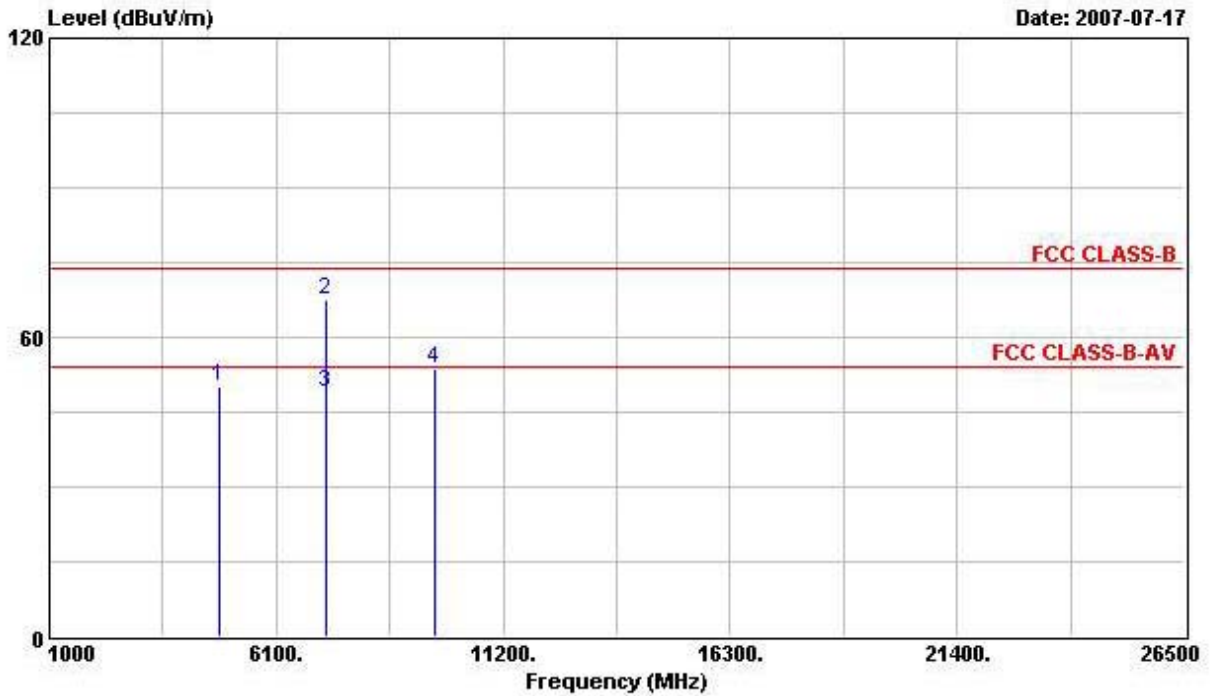

	Freq	Level	Read Level	Over Limit	Limit	Antenna Line Factor	Cable Loss	Preamp Factor	Remark
	MHz	dBuV/m	dBuV	dB	dBuV/m	dB/m	dB	dB	
1	4824.000	49.99	45.32	-4.01	54.00	33.06	4.35	32.74	Average
2	7236.000	67.57	59.56	-6.43	74.00	35.78	5.18	32.95	PEAK
3	7236.000	48.94	40.93	-5.06	54.00	35.78	5.18	32.95	Average
4	9648.000	53.54	42.05			38.41	6.48	33.40	PEAK

Note: Items 4 is on un-restricted band, so the limit is -20dBc for the field strength of the fundamental emissions (see section 3.6.7).



<b>Temperature</b>	25°C	<b>Humidity</b>	54%
<b>Test Engineer</b>	Duncan	<b>Configurations</b>	802.11g CH 6

**Horizontal**

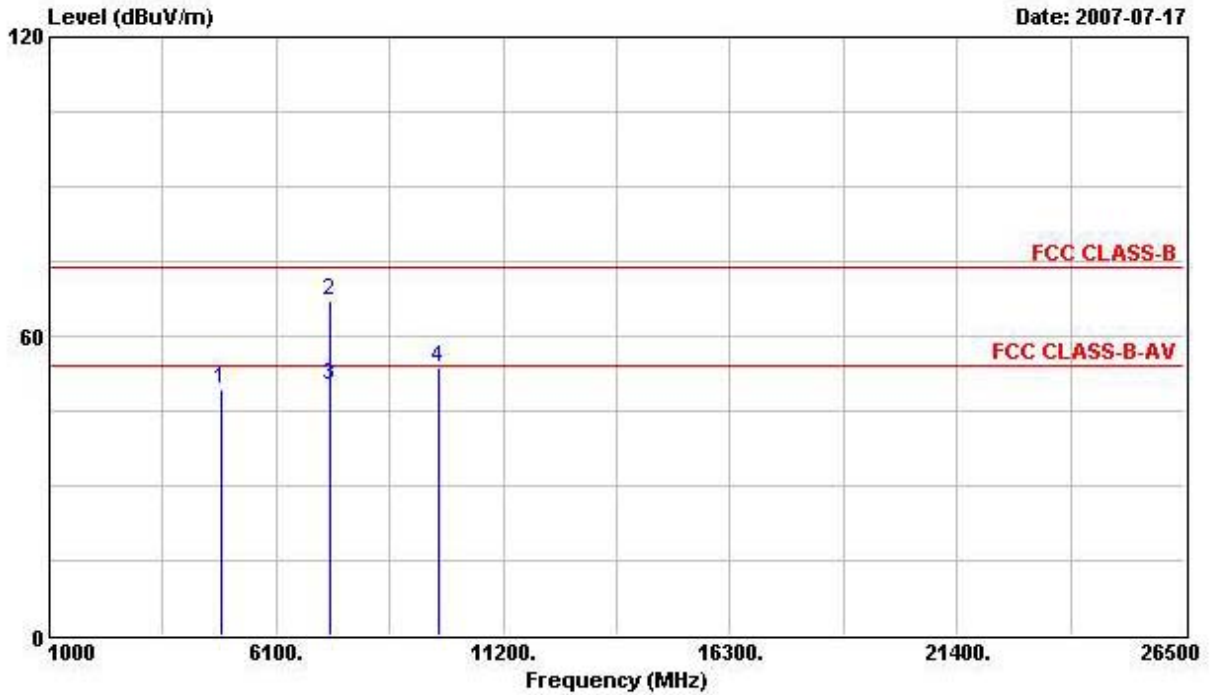

	Freq	Level	Read Level	Over Limit	Limit	Antenna Line Factor	Cable Loss	Preamp Factor	Remark
	MHz	dBUV/m	dBuV	dB	dBUV/m	dB/m	dB	dB	
1	4876.000	49.17	44.37	-4.83	54.00	33.16	4.36	32.73	Average
2	7312.000	67.23	58.95	-6.77	74.00	35.94	5.30	32.97	PEAK
3	7312.000	50.05	41.77	-3.95	54.00	35.94	5.30	32.97	Average
4	9744.000	53.54	41.77			38.58	6.58	33.40	PEAK

Note: Items 4 is on un-restricted band, so the limit is -20dBc for the field strength of the fundamental emissions (see section 3.6.7).

Vertical

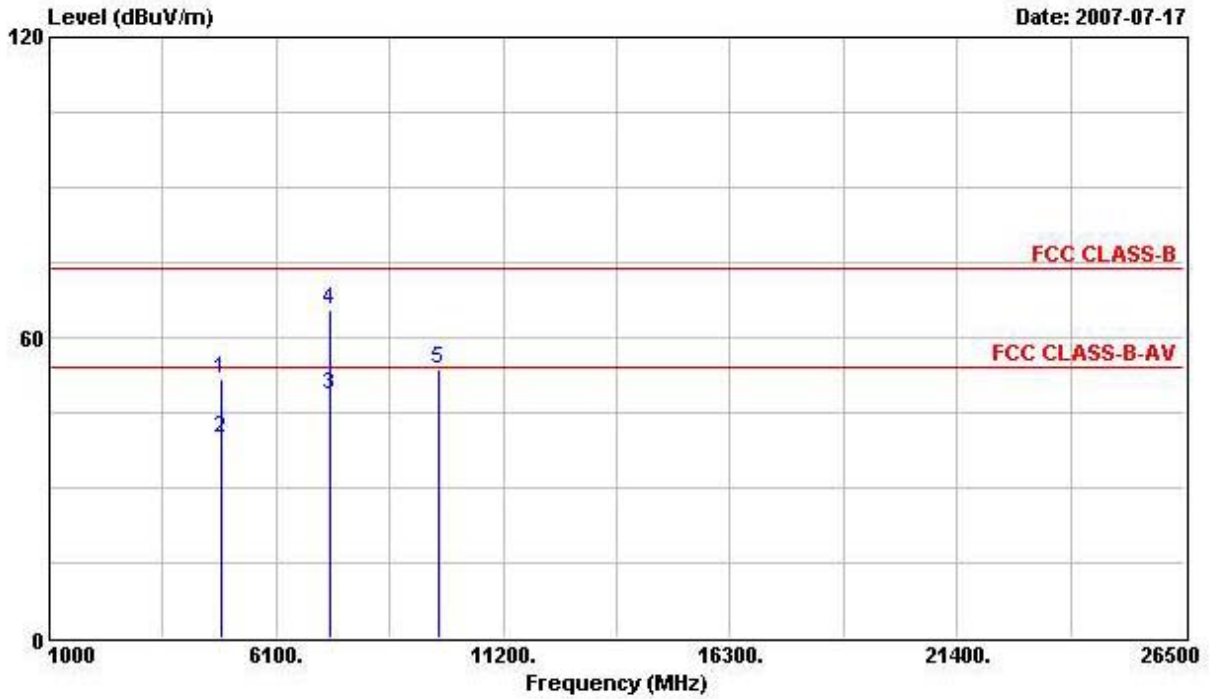

	Freq	Level	Read Level	Over Limit	Limit	Antenna Line Factor	Cable Loss	Preamp Factor	Remark
	MHz	dBuV/m	dBuV	dB	dBuV/m	dB/m	dB	dB	
1	4872.000	51.64	46.84	-22.36	74.00	33.16	4.36	32.73	Peak
2	4872.000	40.01	35.21	-13.99	54.00	33.16	4.36	32.73	Average
3	7312.000	48.39	40.11	-5.61	54.00	35.94	5.30	32.97	Average
4	7312.000	65.49	57.21	-8.51	74.00	35.94	5.30	32.97	Peak
5	9744.000	53.52	41.75			38.58	6.58	33.40	Peak

Note: Items 5 is on un-restricted band, so the limit is -20dBc for the field strength of the fundamental emissions (see section 3.6.7).

Temperature	25°C	Humidity	54%
Test Engineer	Duncan	Configurations	802.11g CH 11

Horizontal

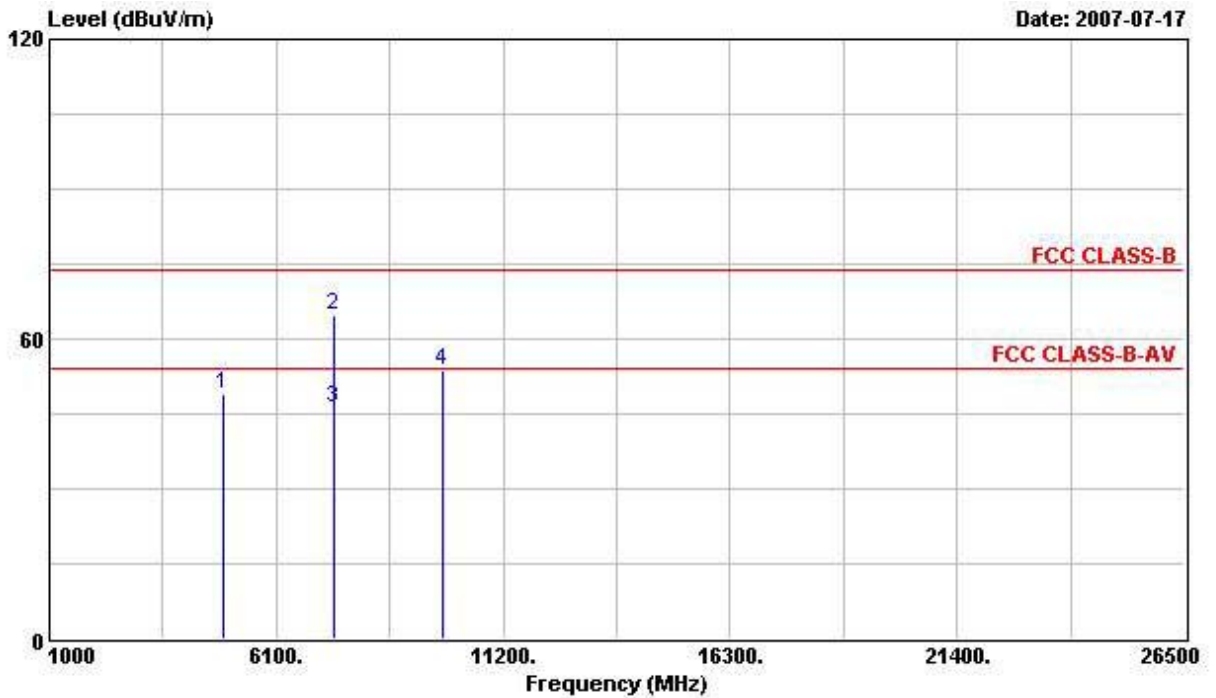

	Freq	Level	Read Level	Over Limit	Limit	Antenna Line Factor	Cable Loss	Preamp Factor	Remark
	MHz	dBuV/m	dBuV	dB	dBuV/m	dB/m	dB	dB	
1	4924.000	49.10	44.15	-4.90	54.00	33.26	4.40	32.72	Average
2	7384.000	64.76	56.17	-9.24	74.00	36.15	5.41	32.98	PEAK
3	7384.000	46.38	37.79	-7.62	54.00	36.15	5.41	32.98	Average
4	9848.000	53.72	41.59			38.79	6.74	33.40	PEAK

Note: Items 4 is on un-restricted band, so the limit is -20dBc for the field strength of the fundamental emissions (see section 3.6.7).

Vertical

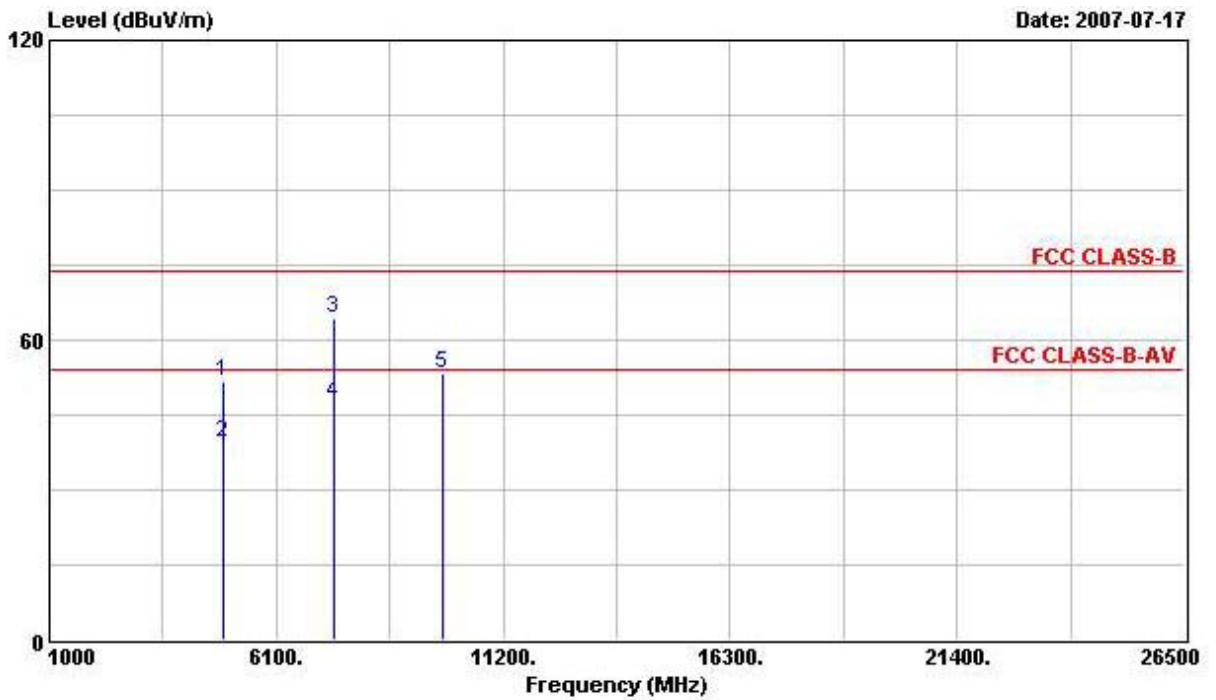

	Freq	Level	Read Level	Over Limit	Limit	Antenna Line Factor	Cable Loss	Preamp Factor	Remark
	MHz	dBuV/m	dBuV	dB	dBuV/m	dB/m	dB	dB	
1	4924.000	51.75	46.81	-22.25	74.00	33.26	4.40	32.72	PEAK
2	4924.000	39.39	34.45	-14.61	54.00	33.26	4.40	32.72	Average
3	7384.000	64.26	55.67	-9.74	74.00	36.15	5.41	32.98	PEAK
4	7384.000	47.48	38.89	-6.52	54.00	36.15	5.41	32.98	Average
5	9852.000	53.44	41.27			38.82	6.74	33.40	PEAK

Note: Items 5 is on un-restricted band, so the limit is -20dBc for the field strength of the fundamental emissions (see section 3.6.7).

**3.6. Band Edge Emissions Measurement**

**3.6.1. Limit**

20dBc in any 100 kHz bandwidth outside the operating frequency band. In case the emission fall within the restricted band specified on 15.205(a), then the 15.209(a) limit in the table below has to be followed.

<b>Frequencies (MHz)</b>	<b>Field Strength (micorvolts/meter)</b>	<b>Measurement Distance (meters)</b>
0.009~0.490	2400/F(KHz)	300
0.490~1.705	24000/F(KHz)	30
1.705~30.0	30	30
30~88	100	3
88~216	150	3
216~960	200	3
Above 960	500	3

**3.6.2. Measuring Instruments and Setting**

Please refer to section 4 of equipments list in this report. The following table is the setting of the spectrum analyzer.

<b>Spectrum Parameter</b>	<b>Setting</b>
Attenuation	Auto
Span Frequency	100 MHz
RB / VB (Emission in restricted band)	1MHz / 1MHz for Peak, 1 MHz / 10Hz for Average
RB / VB (Emission in non-restricted band)	100 KHz /100 KHz for Peak

**3.6.3. Test Procedures**

1. The test procedure is the same as section 3.5.3, only the frequency range investigated is limited to 100MHz around bandedges.
2. In case the emission is fail due to the used RB/VB is too wide, marker-delta method of FCC Public Notice DA00-705 will be followed.

**3.6.4. Test Setup Layout**

This test setup layout is the same as that shown in section 3.5.4.

**3.6.5. Test Deviation**

There is no deviation with the original standard.

**3.6.6. EUT Operation during Test**

The EUT was programmed to be in continuously transmitting mode.

**3.6.7. Test Result of Band Edge and Fundamental Emissions**

<b>Temperature</b>	25°C	<b>Humidity</b>	54%
<b>Test Engineer</b>	Duncan	<b>Configurations</b>	802.11b CH 1, 6, 11

**Channel 1**

	<b>Freq</b>	<b>Level</b>	<b>Read Level</b>	<b>Over Limit</b>	<b>Limit</b>	<b>Antenna Line Factor</b>	<b>Cable Loss</b>	<b>Preamp Factor</b>	<b>Remark</b>
	<b>MHz</b>	<b>dBuV/m</b>	<b>dBuV</b>	<b>dB</b>	<b>dBuV/m</b>	<b>dB/m</b>	<b>dB</b>	<b>dB</b>	
<b>1</b>	<b>2390.000</b>	<b>57.72</b>	<b>26.60</b>	<b>-16.28</b>	<b>74.00</b>	<b>28.29</b>	<b>2.82</b>	<b>0.00</b>	<b>Peak</b>
<b>2 @</b>	<b>2414.500</b>	<b>109.24</b>	<b>78.09</b>			<b>28.33</b>	<b>2.82</b>	<b>0.00</b>	<b>Peak</b>
<b>1</b>	<b>2390.000</b>	<b>45.63</b>	<b>14.51</b>	<b>-8.37</b>	<b>54.00</b>	<b>28.29</b>	<b>2.82</b>	<b>0.00</b>	<b>Average</b>
<b>2 @</b>	<b>2414.500</b>	<b>99.77</b>	<b>68.62</b>			<b>28.33</b>	<b>2.82</b>	<b>0.00</b>	<b>Average</b>

**Channel 6**

	<b>Freq</b>	<b>Level</b>	<b>Read Level</b>	<b>Over Limit</b>	<b>Limit</b>	<b>Antenna Line Factor</b>	<b>Cable Loss</b>	<b>Preamp Factor</b>	<b>Remark</b>
	<b>MHz</b>	<b>dBuV/m</b>	<b>dBuV</b>	<b>dB</b>	<b>dBuV/m</b>	<b>dB/m</b>	<b>dB</b>	<b>dB</b>	
<b>1 @</b>	<b>2438.060</b>	<b>102.26</b>	<b>71.02</b>			<b>28.40</b>	<b>2.85</b>	<b>0.00</b>	<b>Peak</b>
<b>1 @</b>	<b>2438.060</b>	<b>93.28</b>	<b>62.04</b>			<b>28.40</b>	<b>2.85</b>	<b>0.00</b>	<b>Average</b>

**Channel 11**

	<b>Freq</b>	<b>Level</b>	<b>Read Level</b>	<b>Over Limit</b>	<b>Limit</b>	<b>Antenna Line Factor</b>	<b>Cable Loss</b>	<b>Preamp Factor</b>	<b>Remark</b>
	<b>MHz</b>	<b>dBuV/m</b>	<b>dBuV</b>	<b>dB</b>	<b>dBuV/m</b>	<b>dB/m</b>	<b>dB</b>	<b>dB</b>	
<b>1 @</b>	<b>2464.090</b>	<b>105.18</b>	<b>73.88</b>			<b>28.43</b>	<b>2.87</b>	<b>0.00</b>	<b>Peak</b>
<b>2</b>	<b>2483.500</b>	<b>56.37</b>	<b>25.03</b>	<b>-17.63</b>	<b>74.00</b>	<b>28.47</b>	<b>2.87</b>	<b>0.00</b>	<b>Peak</b>
<b>1 @</b>	<b>2464.090</b>	<b>97.47</b>	<b>66.17</b>			<b>28.43</b>	<b>2.87</b>	<b>0.00</b>	<b>Average</b>
<b>2</b>	<b>2483.500</b>	<b>44.78</b>	<b>13.44</b>	<b>-9.22</b>	<b>54.00</b>	<b>28.47</b>	<b>2.87</b>	<b>0.00</b>	<b>Average</b>

<b>Temperature</b>	25°C	<b>Humidity</b>	54%
<b>Test Engineer</b>	Duncan	<b>Configurations</b>	802.11g CH 1, 6, 11

**Channel 1**

	<b>Freq</b>	<b>Level</b>	<b>Read Level</b>	<b>Over Limit</b>	<b>Limit</b>	<b>Antenna Line Factor</b>	<b>Cable Loss</b>	<b>Preamp Factor</b>	<b>Remark</b>
	<b>MHz</b>	<b>dBuV/m</b>	<b>dBuV</b>	<b>dB</b>	<b>dBuV/m</b>	<b>dB/m</b>	<b>dB</b>	<b>dB</b>	
<b>1</b>	<b>2390.000</b>	<b>67.27</b>	<b>36.15</b>	<b>-6.73</b>	<b>74.00</b>	<b>28.29</b>	<b>2.82</b>	<b>0.00</b>	<b>Peak</b>
<b>2 @</b>	<b>2416.780</b>	<b>104.44</b>	<b>73.29</b>			<b>28.33</b>	<b>2.82</b>	<b>0.00</b>	<b>Peak</b>
<b>1</b>	<b>2390.000</b>	<b>49.35</b>	<b>18.23</b>	<b>-4.65</b>	<b>54.00</b>	<b>28.29</b>	<b>2.82</b>	<b>0.00</b>	<b>Average</b>
<b>2 @</b>	<b>2416.780</b>	<b>94.50</b>	<b>63.35</b>			<b>28.33</b>	<b>2.82</b>	<b>0.00</b>	<b>Average</b>

**Channel 6**

	<b>Freq</b>	<b>Level</b>	<b>Read Level</b>	<b>Over Limit</b>	<b>Limit</b>	<b>Antenna Line Factor</b>	<b>Cable Loss</b>	<b>Preamp Factor</b>	<b>Remark</b>
	<b>MHz</b>	<b>dBuV/m</b>	<b>dBuV</b>	<b>dB</b>	<b>dBuV/m</b>	<b>dB/m</b>	<b>dB</b>	<b>dB</b>	
<b>1 @</b>	<b>2430.650</b>	<b>99.25</b>	<b>68.04</b>			<b>28.36</b>	<b>2.85</b>	<b>0.00</b>	<b>Peak</b>
<b>1 @</b>	<b>2430.650</b>	<b>89.60</b>	<b>58.39</b>			<b>28.36</b>	<b>2.85</b>	<b>0.00</b>	<b>Average</b>

**Channel 11**

	<b>Freq</b>	<b>Level</b>	<b>Read Level</b>	<b>Over Limit</b>	<b>Limit</b>	<b>Antenna Line Factor</b>	<b>Cable Loss</b>	<b>Preamp Factor</b>	<b>Remark</b>
	<b>MHz</b>	<b>dBuV/m</b>	<b>dBuV</b>	<b>dB</b>	<b>dBuV/m</b>	<b>dB/m</b>	<b>dB</b>	<b>dB</b>	
<b>1 @</b>	<b>2466.940</b>	<b>100.11</b>	<b>68.81</b>			<b>28.43</b>	<b>2.87</b>	<b>0.00</b>	<b>Peak</b>
<b>2</b>	<b>2483.500</b>	<b>62.41</b>	<b>31.07</b>	<b>-11.59</b>	<b>74.00</b>	<b>28.47</b>	<b>2.87</b>	<b>0.00</b>	<b>Peak</b>
<b>1 @</b>	<b>2466.940</b>	<b>90.26</b>	<b>58.96</b>			<b>28.43</b>	<b>2.87</b>	<b>0.00</b>	<b>Average</b>
<b>2</b>	<b>2483.500</b>	<b>47.46</b>	<b>16.12</b>	<b>-6.54</b>	<b>54.00</b>	<b>28.47</b>	<b>2.87</b>	<b>0.00</b>	<b>Average</b>

Note:

Emission level (dBuV/m) = 20 log Emission level (uV/m).

Corrected Reading: Antenna Factor + Cable Loss + Read Level - Preamp Factor = Level.

For Emission not in Restricted Band

Low Band Edge Plot on Configuration IEEE 802.11b / 2412 MHz

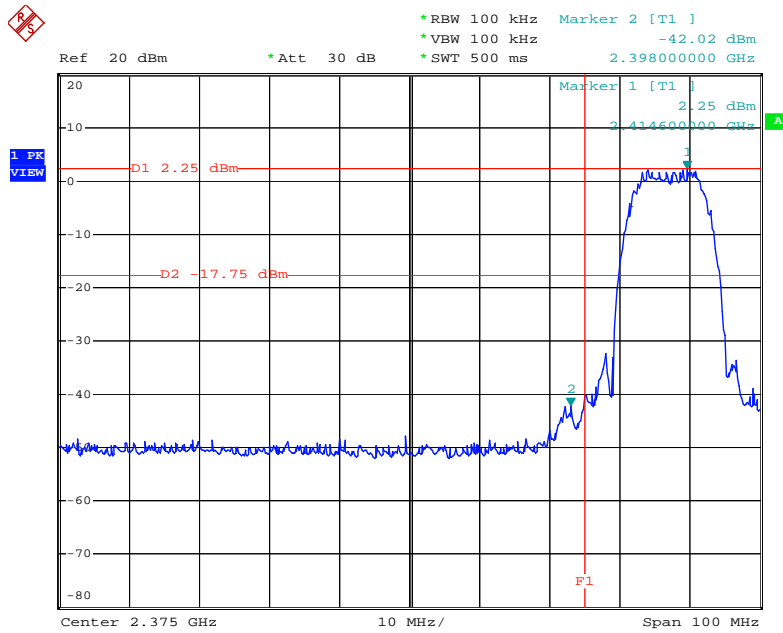

Date: 31.JUL.2007 23:08:24

High Band Edge Plot on Configuration IEEE 802.11b / 2462 MHz

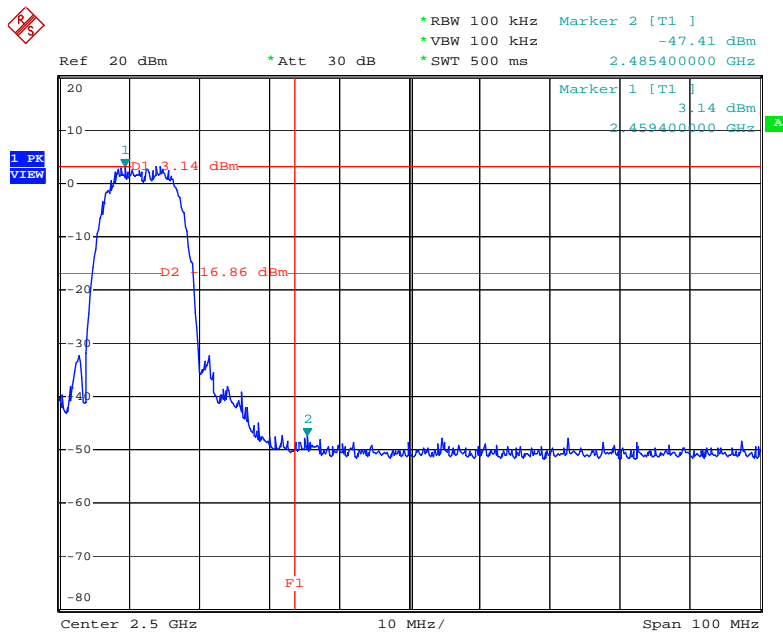

Date: 31.JUL.2007 23:02:22



Low Band Edge Plot on Configuration IEEE 802.11g / 2412 MHz

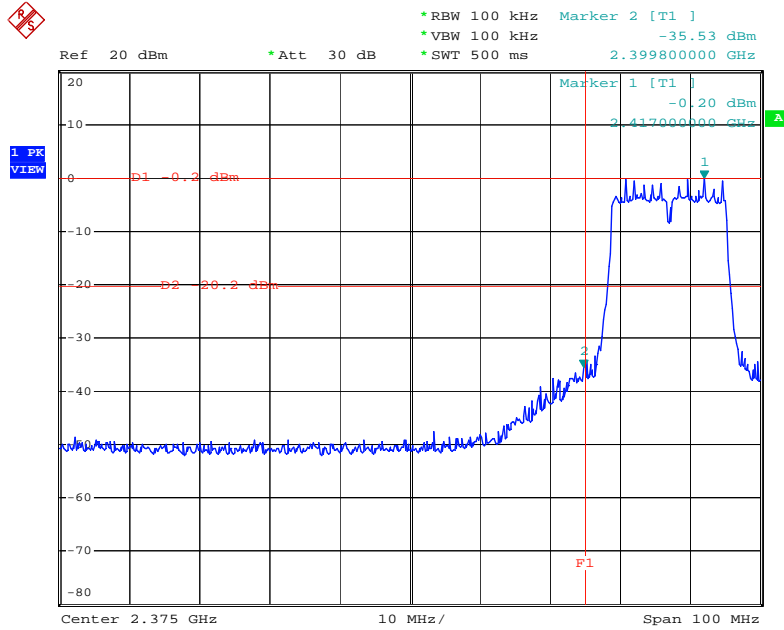

Date: 31.JUL.2007 23:30:05

High Band Edge Plot on Configuration IEEE 802.11g / 2462 MHz

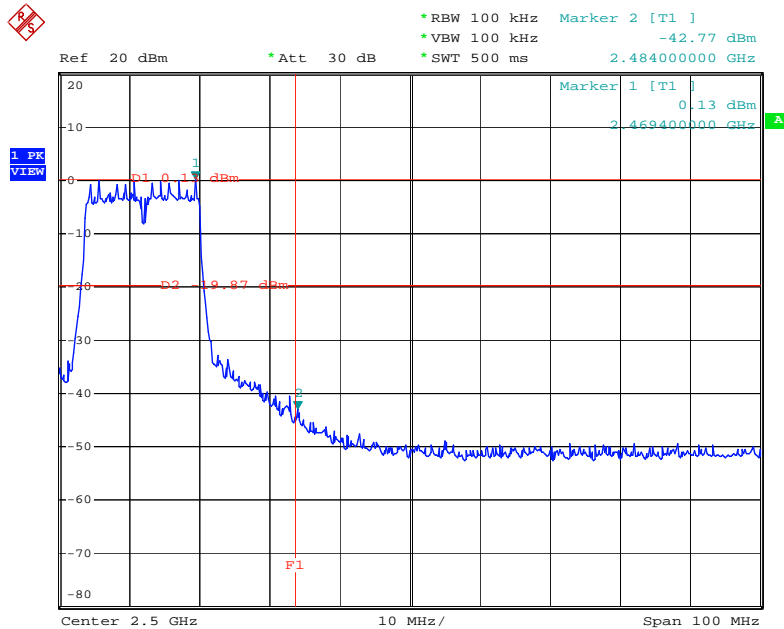

Date: 31.JUL.2007 23:41:41

### **3.7. Antenna Requirements**

#### **3.7.1. Limit**

Except for special regulations, the Low-power Radio-frequency Devices must not be equipped with any jacket for installing an antenna with extension cable. An intentional radiator shall be designed to ensure that no antenna other than that furnished by the responsible party shall be used with the device. The use of a permanently attached antenna or of an antenna that uses a unique coupling to the intentional radiator shall be considered sufficient to comply with the provisions of this Section. The manufacturer may design the unit so that the user can replace a broken antenna, but the use of a standard antenna jack or electrical connector is prohibited. Further, this requirement does not apply to intentional radiators that must be professionally installed.

#### **3.7.2. Antenna Connector Construction**

Please refer to section 2.3 in this test report; antenna connector complied with the requirements.

**4. LIST OF MEASURING EQUIPMENTS**

Instrument	Manufacturer	Model No.	Serial No.	Characteristics	Calibration Date	Remark
EMC Receiver	R&S	ESCS 30	100132	9kHz – 2.75GHz	Aug. 30, 2006	Conduction (CO01-HY)
LISN	MessTec	NNB-2/16Z	2001/004	9kHz – 30MHz	Mar. 30, 2007	Conduction (CO01-HY)
LISN (Support Unit)	MessTec	NNB-2/16Z	2001/009	9kHz – 30MHz	Mar. 30, 2007	Conduction (CO01-HY)
EMI Filter	LINDGREN	LRE-2060	1004	< 450Hz	N/A	Conduction (CO01-HY)
EMI Filter	LINDGREN	N6006	201052	0 – 60Hz	N/A	Conduction (CO01-HY)
RF Cable-CON	Suhner Switzerland	RG223/U	CB029	9kHz – 30MHz	Dec. 04, 2006	Conduction (CO01-HY)
Isolation Transformer	Erika Fiedler OHG	D-65396 Walluf	58	45MHz-2.15GHz	N/A	Conduction (CO01-HY)
3m Semi Anechoic Chamber	SIDT FRANKONIA	SAC-3M	03CH03-HY	30 MHz - 1 GHz 3m	Jun. 14, 2007	Radiation (03CH03-HY)
Amplifier	SCHAFFNER	CPA9231A	1886	9 kHz - 2 GHz	Jan. 22, 2007	Radiation (03CH03-HY)
Amplifier	Agilent	8449B	3008A02120	1 GHz - 26.5 GHz	Jun.07, 2007	Radiation (03CH03-HY)
Spectrum Analyzer	R&S	FSP40	100004/040	9 kHz - 40 GHz	Sep. 21, 2006	Radiation (03CH03-HY)
Bilog Antenna	SCHAFFNER	CBL 6112D	22237	30 MHz – 1 GHz	Jul. 21, 2007	Radiation (03CH03-HY)
Horn Antenna	EMCO	3115	6741	1GHz ~ 18GHz	May 04, 2007	Radiation (03CH03-HY)
Horn Antenna	SCHWARZBECK	BBHA9170	BBHA9170154	15 GHz - 40 GHz	NCR	Radiation (03CH03-HY)
RF Cable-R03m	Jye Bao	RG142	CB021	30 MHz - 1 GHz	Dec. 02, 2006	Radiation (03CH03-HY)
RF Cable-HIGH	SUHNER	SUCOFLEX 106	03CH03-HY	1 GHz - 40 GHz	Dec. 02, 2006	Radiation (03CH03-HY)
Turn Table	HD	DS 420	420/650/00	0 – 360 degree	N/A	Radiation (03CH03-HY)
Antenna Mast	HD	MA 240	240/560/00	1 m - 4 m	N/A	Radiation (03CH03-HY)
Spectrum Analyzer	R&S	FSP30	100023	9kHz ~ 30GHz	Dec. 17, 2006	Conducted (TH01-HY)
Power Meter	R&S	NRVS	100444	DC ~ 40GHz	Jun. 27, 2007	Conducted (TH01-HY)
Power Sensor	R&S	NRV-Z51	100458	DC ~ 30GHz	Jun. 27, 2007	Conducted (TH01-HY)
Power Sensor	R&S	NRV-Z32	100057	30MHz ~ 6GHz	Jun. 27, 2007	Conducted (TH01-HY)
DC Power Source	G.W.	GPC-6030D	C671845	DC 1V ~ 60V	Mar. 03, 2007	Conducted (TH01-HY)
Temp. and Humidity Chamber	KSON	THS-C3L	612	N/A	Oct. 02, 2006	Conducted (TH01-HY)
RF CABLE-1m	Jye Bao	RG142	CB034-1m	20MHz ~ 7GHz	Dec. 01, 2006	Conducted (TH01-HY)
RF CABLE-2m	Jye Bao	RG142	CB035-2m	20MHz ~ 1GHz	Dec. 01, 2006	Conducted (TH01-HY)
Vector Signal Generator	R&S	SMU200A	102098	100kHz ~ 6GHz	Nov. 14, 2006	Conducted (TH01-HY)
Signal Generator	R&S	SMR40	100116	10MHz ~ 40GHz	Mar. 07, 2007	Conducted (TH01-HY)

Note: Calibration Interval of instruments listed above is one year. NCR: Non-Calibration required.

Instrument	Manufacturer	Model No.	Serial No.	Characteristics	Calibration Date	Remark
Amplifier	MITEQ	AMF-6F-260400	923364	26.5 GHz - 40 GHz	Jan. 22, 2007*	Radiation (03CH03-HY)
Loop Antenna	R&S	HFH2-Z2	860004/001	9 kHz - 30 MHz	May 23, 2006*	Radiation (03CH03-HY)
AC Power Source	HPC	HPA-500W	HPA-9100024	AC 0 ~ 300V	May 04, 2007*	Conducted (TH01-HY)

Note: Calibration Interval of instruments listed above is two year.

## 5. TEST LOCATION

SHIJR	ADD : 6Fl., No. 106, Sec. 1, Shintai 5th Rd., Shijr City, Taipei, Taiwan 221, R.O.C. TEL : 886-2-2696-2468 FAX : 886-2-2696-2255
HWA YA	ADD : No. 52, Hwa Ya 1st Rd., Kwei-Shan Hsiang, Tao Yuan Hsien, Taiwan, R.O.C. TEL : 886-3-327-3456 FAX : 886-3-318-0055
LINKOU	ADD : No. 30-2, Dingfu Tsuen, Linkou Shiang, Taipei, Taiwan 244, R.O.C TEL : 886-2-2601-1640 FAX : 886-2-2601-1695
DUNGHU	ADD : No. 3, Lane 238, Kangle St., Neihu Chiu, Taipei, Taiwan 114, R.O.C. TEL : 886-2-2631-4739 FAX : 886-2-2631-9740
JUNGHE	ADD : 7Fl., No. 758, Jungjeng Rd., Junghe City, Taipei, Taiwan 235, R.O.C. TEL : 886-2-8227-2020 FAX : 886-2-8227-2626
NEIHU	ADD : 4Fl., No. 339, Hsin Hu 2 <sup>nd</sup> Rd., Taipei 114, Taiwan, R.O.C. TEL : 886-2-2794-8886 FAX : 886-2-2794-9777
JHUBEI	ADD : No.8, Lane 724, Bo-ai St., Jhubei City, HsinChu County 302, Taiwan, R.O.C. TEL : 886-3-656-9065 FAX : 886-3-656-9085

6. TAF CERTIFICATE OF ACCREDITATION



Certificate No. : L1190-070110

財團法人全國認證基金會  
Taiwan Accreditation Foundation

Certificate of Accreditation

This is to certify that

**Sporton International Inc.**

**EMC & Wireless Communications Laboratory**

No.52, Hwa Ya 1st Rd., Hwa Ya Technology Park, Kwei-Shan Hsiang, Tao Yuan Hsien,  
Taiwan, R.O.C.

is accredited in respect of laboratory

- Accreditation Criteria : ISO/IEC 17025:2005
- Accreditation Number : 1190
- Originally Accredited : December 15, 2003
- Effective Period : January 10, 2007 to January 09, 2010
- Accredited Scope : Testing Field, see described in the Appendix
- Specific Accreditation Program : Accreditation Program for Designated Testing Laboratory  
for Commodities Inspection  
Accreditation Program for Telecommunication Equipment  
Testing Laboratory

Jay-San Chen  
President, Taiwan Accreditation Foundation  
Date : January 10, 2007

Pl. total 9 pages

The Appendix forms an integral part of this Certificate, which shall be invalid when used without the Appendix.