

VDP-A1
Video Door Phone
Installation Guide

Table of Contents

1.	INTRODUCTION	8
2.	APPLICATION OVERVIEW	9
2.1.	PARTS IDENTIFICATION	9
2.2.	LED INDICATOR	10
2.3.	THE POWER SUPPLY	10
3.	GETTING STARTED	11
3.1.	EQUIPMENT REQUIRED	11
3.2.	HARDWARE INSTALLATION	11
3.3.	WI-FI SETUP AND LEARNING	13
4.	OPERATION	16
4.1.	WEB BROWSER ACCESS	16
4.2.	SMARTPHONE ACCESS	17
4.3.	DOORBELL NOTIFICATION	18
4.4.	VIDEO / PICTURE CAPTURE	19
5.	PROGRAMMING	20
5.1.	VIDEO SETTING	20
5.2.	VDP SETTING	23
6.	LOCAL PROGRAMMING WEBPAGE	28
6.1.	CONNECTING TO WEBPAGE	30
7.	IP CAMERA	31
7.1.	IMAGE TUNING	31
7.2.	TIME STAMP	32
7.3.	STREAM SETTING	33
7.4.	RECORDED FILES	34
7.5.	ALARM SETTING	35
8.	NETWORK SETTING	36
8.1.	NETWORK	36
8.2.	WIRELESS	37
8.3.	UPNP	38
9.	SYSTEM SETTING	39
9.1.	CHANGE PASSWORD	39

9.2.	REPORT	40
9.3.	MEDIA UPLOAD	41
9.4.	XMPP	42
9.5.	DATE & TIME	43
9.6.	DYNAMIC DNS	44
9.7.	FIRMWARE	45
9.8.	FACTORY RESET	46
9.9.	BACKUP & RESTORE	47
9.10.	SYSTEM LOG	48
9.11.	LOGOUT	49
9.12.	REBOOT	49
10.	HISTORY	50
10.1.	EVENT LOG	50
10.2.	REPORTED EVENTS	50

1. Introduction

VDP-A1 Video Door Phone is designed to replace conventional doorbell by providing remote video streaming access, two-way communication via WiFi network. The Video Door Phone functions as part of Climax alarm system and must be connected with a Climax security system Control Panel. Setup and remote access of Video Door Phone is performed via Climax Home Portal Server, using provided smartphone application.

2. Application Overview

2.1. Parts Identification

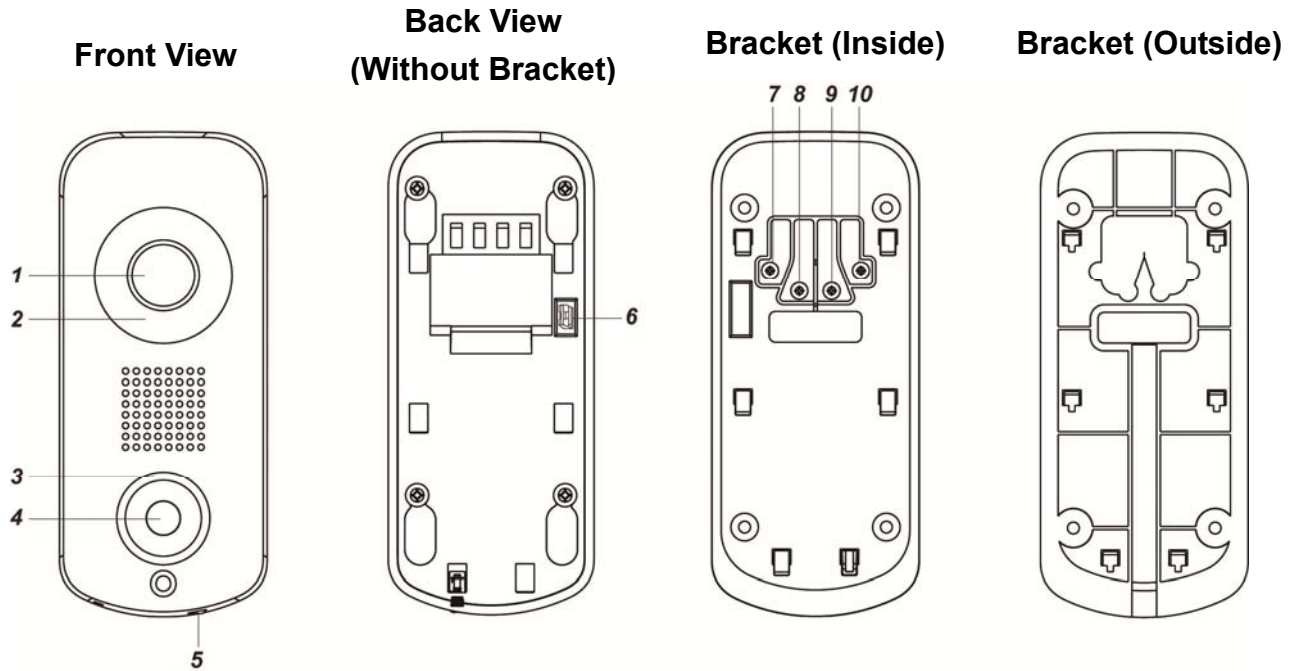

1. Camera Lens
2. Night Light LED
3. LED Indicator (Blue / Amber)
4. Function Button
5. Bottom Screw

The bottom screw should be loosened before hooking the VDP onto mounting bracket, and tightened after VDP is hooked to bracket.

When tightened, the bottom screw fixes VDP to mounting bracket. VDP cannot be detached from bracket as long as screw is tightened.

6. Doorbell Jumper Switch



Jumper On

The jumper link is inserted connecting the two pins.



Jumper Off

If the jumper link is removed or "parked" on one pin.

Jumper ON: Connect the Jumper Switch when using VDP with hardware doorbell.

Jumper OFF: Disconnect the Jumper Switch when not using VDP with hardware Doorbell.

7. 24V ADC Power Input
8. Doorbell Terminal
9. Doorbell Terminal
10. 24V ADC Power Input

2.2. LED Indicator

The Video Door Phone has 2 sets of LED in Blue and Amber color, arranged in circular pattern around the button to indicate device status.

LED Color	Behavior	Indication
Blue	Flash every 3 seconds	VDP under Wi-Fi setup mode (AP mode)
	Spinning	VDP button pressed, waiting for answer
	ON	VDP under video streaming and two-way communication
Amber	ON for 3 seconds	VDP finish warm up upon power on, entering normal operation.
	Flash every 3 seconds	Wi-Fi connectivity problem*
	Flash every second	VDP unable to connect to server
	3 Flash then ON for 6 seconds	VDP reset to factory default

***Note:** It takes about 1 minute for VDP to connect to Wi-Fi after power on. Before the Wi-Fi connection is established, the Amber LED may flash momentarily.

2.3. The Power Supply

The VDP uses $24V \pm 10\%$ AC or DC power as power source. Connect power to the connector on the bracket, install the VDP on the bracket to power on the device.

3. Getting Started

3.1. Equipment required

The following equipment is required to use VDP:

- A Climax IP based security system alarm panel – The panel must be registered in Climax Home Portal Server with a valid user account. Refer to panel and Home Portal Server user guide to complete panel setup and registration process.
- A router supporting 2.4 GHz Wi-Fi network. The Climax panel should be connected to this router with access to internet and Home Portal Server.
- An iPhone or Android smartphone with Climax Vesta Home 2 app installed.

Android version requirement: Android **5.1** or over.

iPhone version requirement: iOS **8** or over

3.2. Hardware Installation

1. Determine whether the VDP would be connected to a conventional doorbell.

If doorbell is used, connect the Jumper Switch.

If doorbell is not used, do NOT connect the Jumper Switch.

Warning

The Jumper Switch setting **MUST** be adjusted according to doorbell usage. Make sure the jumper setting is correct before proceeding with installation. Incorrect setting may cause damage to VDP when wiring.

2. Find the wall mounting bracket, connect 24V±10% ADC power to the connector on the bracket. If doorbell is used, also connect the door bell.

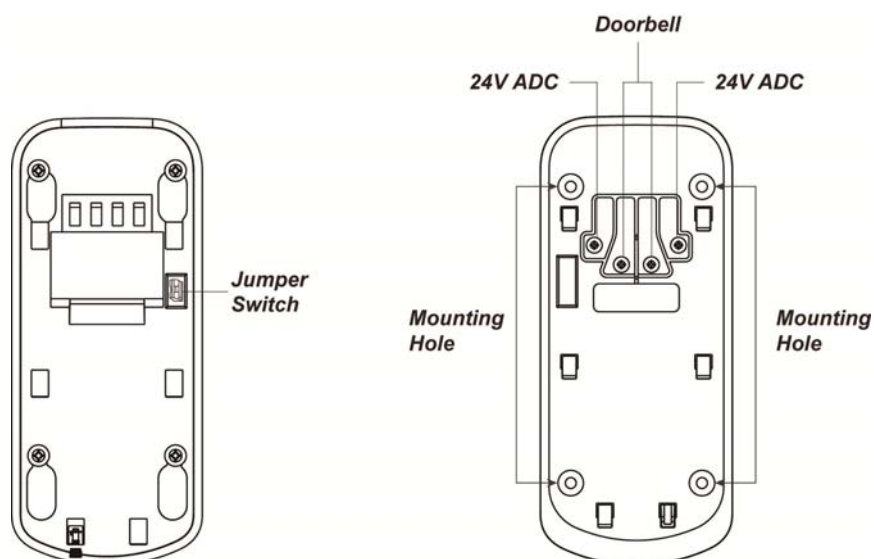

The wiring should connect to the connector on the inside of bracket, pass through the opening on the bracket and tucked into the bracket's central cavity on the back.

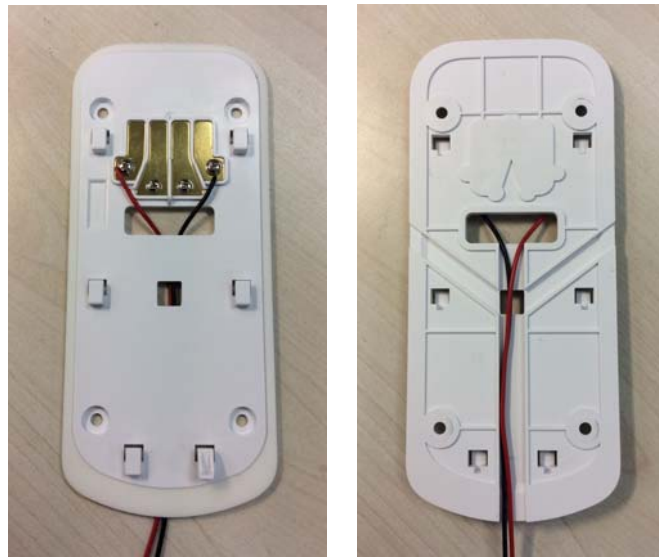

3. The wall mounting bracket has 4 mounting holes. Use the mounting holes as template, mark mounting location on the wall, drill holes and insert wall plug if needed.
4. Screw the mounting bracket onto marked location.
5. Hook VDP onto the bracket. When VDP is hooked on the bracket, the connect come in contact with the device and VDP is powered on.
6. Tighten the bottom screw to lock VDP onto bracket.

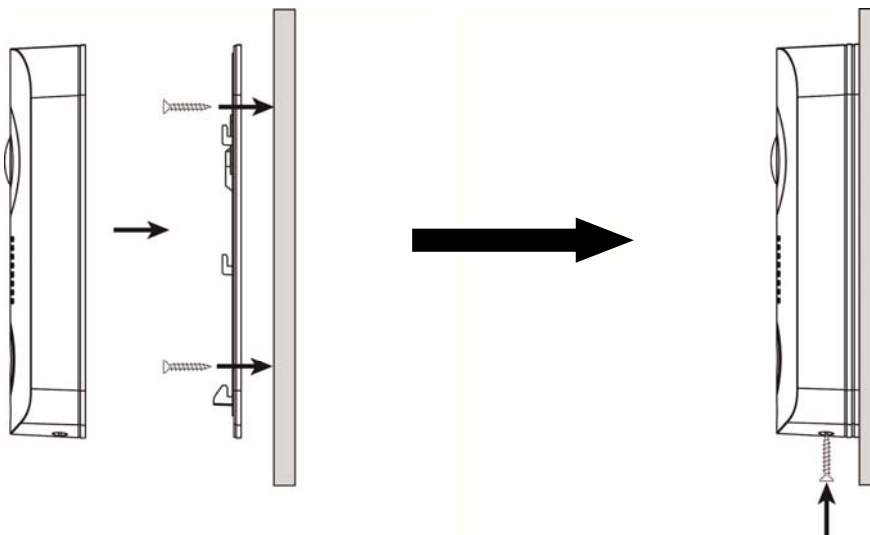

3.3. Wi-Fi Setup and Learning

- 1 Use your smartphone to open Vesta Home 2 app and log into the user account registered by the control panel.
- 2 Select the Camera tab in the app. Press “New Video Doorbell” to begin setting.
- 3 Power up the Video Doorbell by applying AC power. The device will first warm up for about 30 seconds, then the Blue LED will begin to flash.

Flashing Blue LED indicates the Video Doorbell does not have a working Wi-Fi setting and it enter Wi-Fi setup mode (AP mode) automatically upon power up.

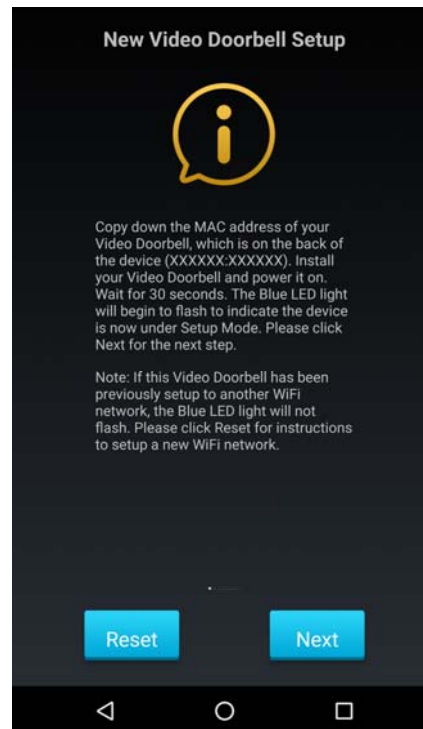
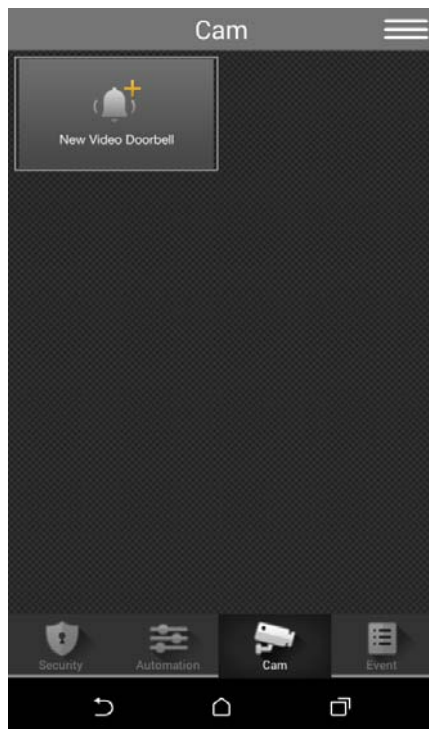

- 4 If the VDP has already finished Wi-Fi setting, it will not enter Wi-Fi setup mode upon power up and must be reset to factory default. Follow procedure below to factory reset:
 - a. Disconnect and reconnect AC power.
 - b. Press and hold VDP button as soon as AC power is reconnected. Do NOT wait for warm up to complete.
 - c. Keep holding the button for about 25 seconds until VDP Amber LED flashes 3 times, then stays ON, then release the button.
 - d. Factory Reset is complete, VDP will reboot and enter W-Fi setup mode.

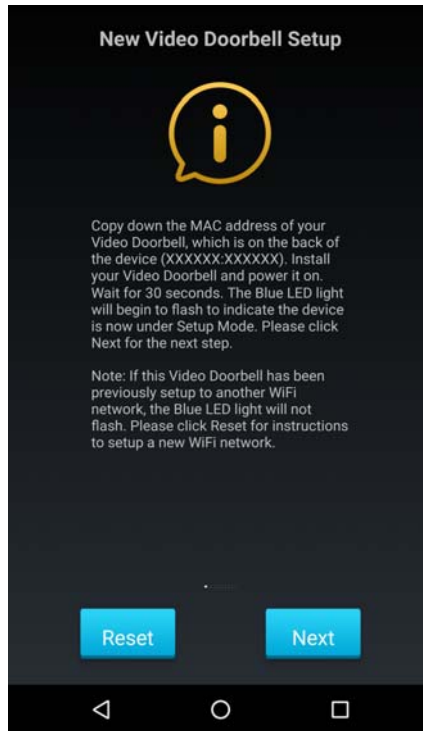

- 5 Leave the Vesta Home 2 TW app in the background and access your Smartphone's Wi-Fi setting function. Look for wireless network named **VDP_XXXXXXXXXXXX**. (XXXXXXXXXXXX = device MAC address) Connect to this wire network, then return to Vesta Home 2 TW app and continue.

If your smartphone warns the network has no internet access, ignore the warning and proceed.

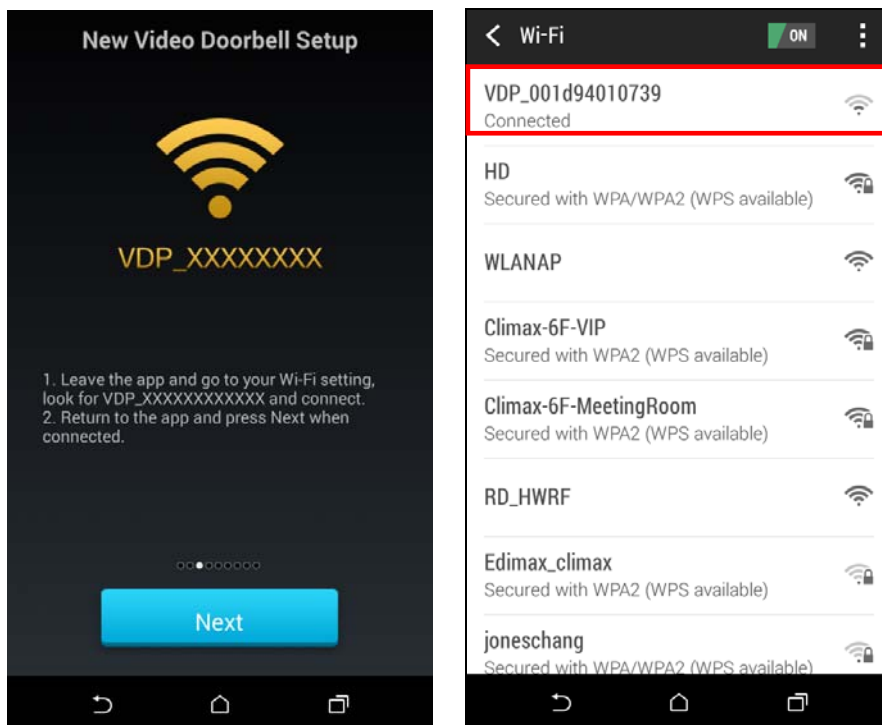

- 6 The app will search for available wireless network and display search result. Select the wireless network desired and enter password to join the network.

If you encounter error message, check your smartphone wireless setting to make sure the smartphone is still connected to the same **VDP_XXXXXXXXXXXX** network

previously selected, then return to app and search the available network again.

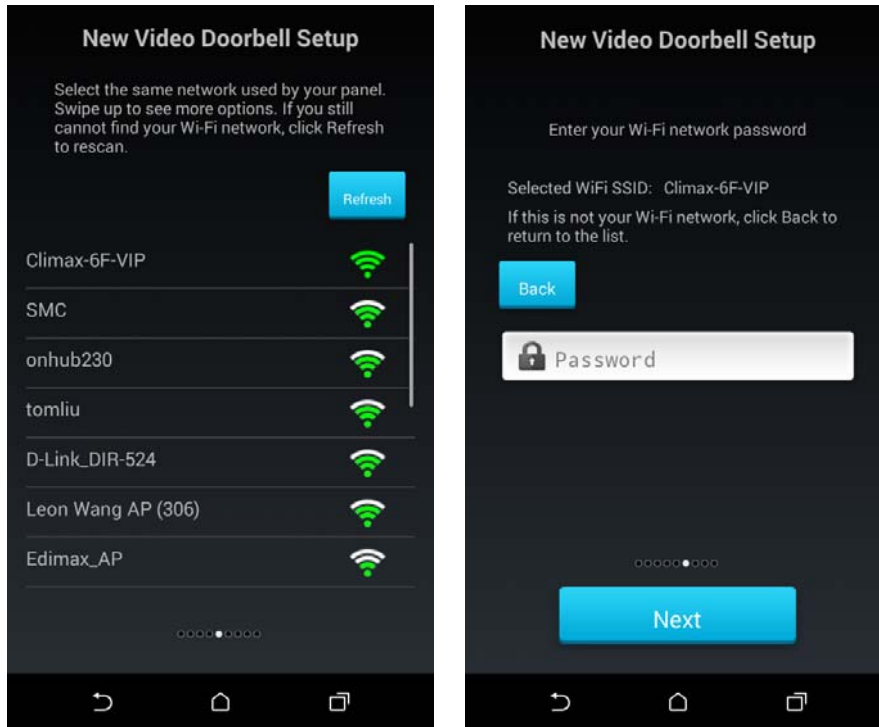

- 7 After successfully joining network, the app proceeds to learn the Video Doorbell into the control panel. Enter the device name and proceed. When learning is complete, the app displays success message. Press Done and re-login to the app to start using Video Doorbell (The device will reboot upon complete learning, you may need to wait a short time for it to restart.)

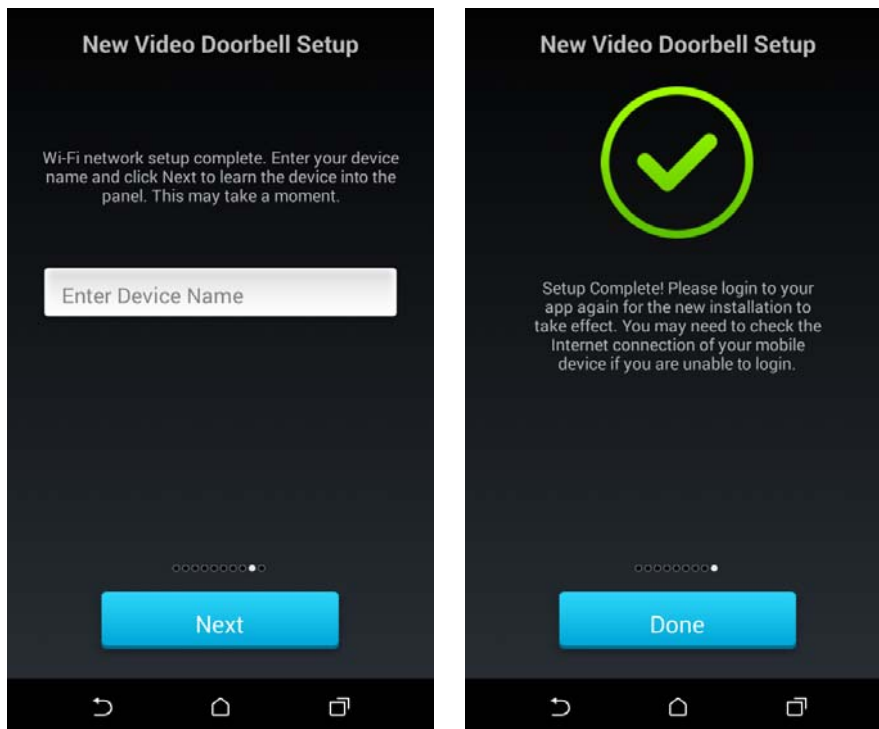

4. Operation

Operation of VDP should be performed via Climax Home Portal Server, using the account registered by the Control Panel which VDP is learnt into.

4.1. Web Browser Access

When accessing the Home Portal Server account using a web browser, VDP is located under the Camera page and has the same function of a Climax IP Camera.

Two-way voice and doorbell functions are not enabled for web browser access. To use these functions, a smartphone app is required. Please see **4.2. Smartphone Access** for detail.

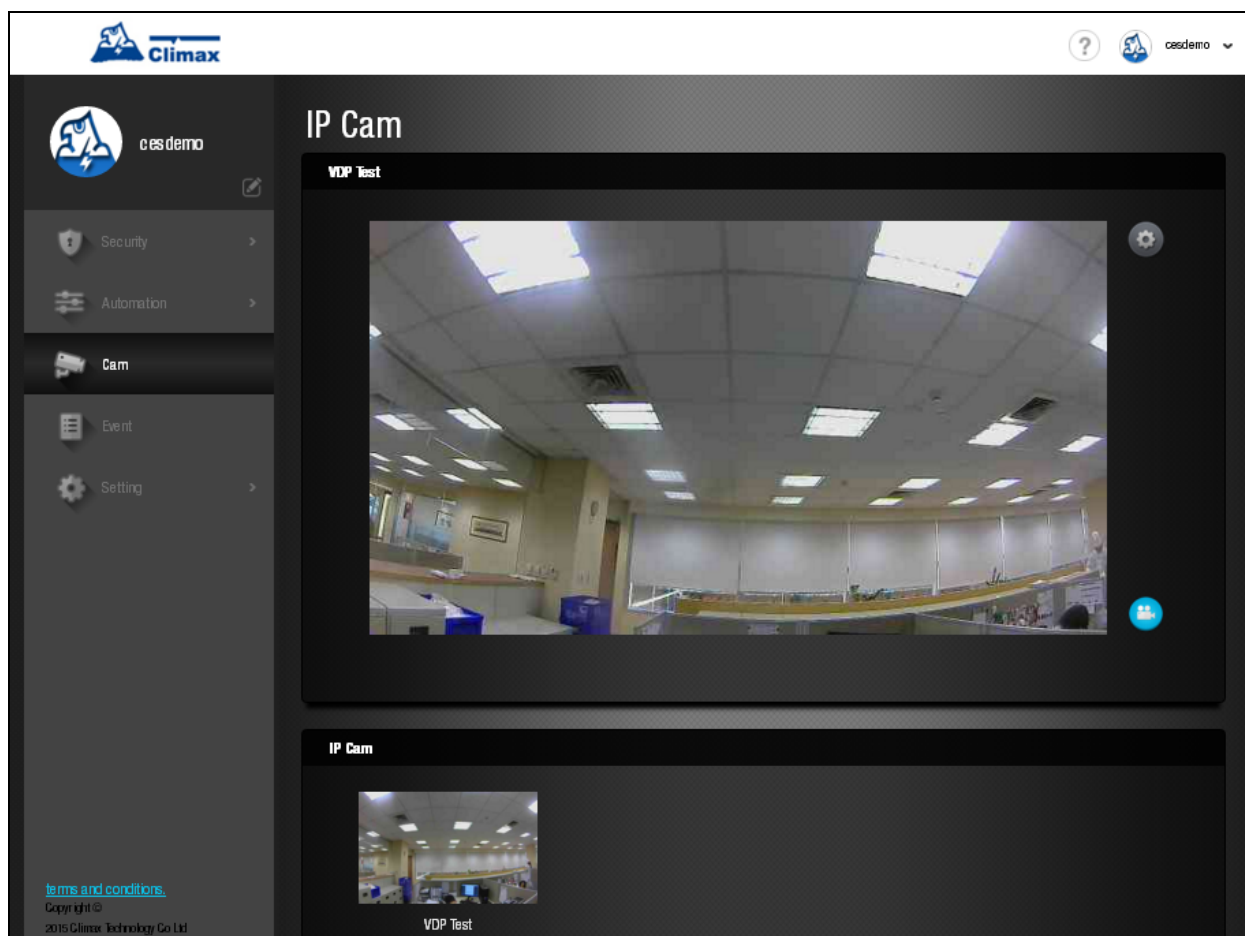

- Press the Record Video button  to record a video clip.





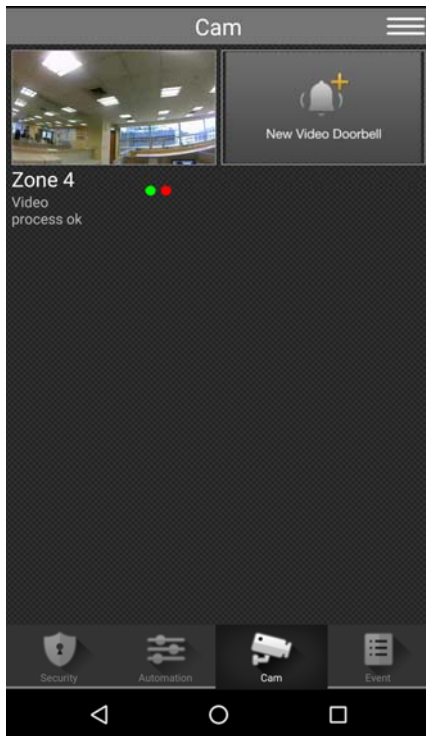

4.2. Smartphone Access

Smartphone application access to VDP provides two-way voice and doorbell push notification function.

Log into Home Portal Account and select Cam page to display VDP streaming thumbnail. Press the thumbnail image to enlarge to full screen.



The VDP full screen has 4 function buttons:

- Press the Record Video button  to record a video clip.
The video clip length is set to 30 seconds by default, composed of 10 seconds before button press and 20 seconds after button press.
- Press the Camera button  to take a single picture.
- Press the Microphone button  to toggle smartphone microphone.
Full screen VDP streaming will open voice channels automatically, allowing smartphone user to converse with VDP. Use the microphone button to control smartphone microphone and switch between one-way and two-way voice channel.
: Smartphone microphone OFF – One-way listen-in only.
: Smartphone Microphone ON – Two-way voice communication.
- Press the Return button  to return to camera thumbnail page.

4.3. Doorbell Notification

The Doorbell Notification function allows VDP to inform the user remotely when its doorbell button is pressed. With Doorbell Notification, the user will be able to answer the doorbell remotely and converse with the guest via VDP using the smartphone even when away from home.

Before using the Doorbell Notification, the following settings should be completed:

- The VDP must be properly setup and learnt into Control Panel, as described in previous chapter.
 - The Control Panel Home Portal Server account should be registered and working properly.
 - The Control Panel Home Portal Server account's push notification setting must be enabled. To enable push notification function, Log into the Home Portal Server account and select Notification setting.
- 1 Press the doorbell button on VDP, VDP will sound a door chime. If any hard wired doorbell is connected to VDP, the doorbell will also be activated; the Blue LED will start spinning.
 - 2 The user will receive a push notification message from its panel Home Portal Server Account, titled "Doorbell"
 - 3 Press on the push notification message, the smartphone will launch Vesta Home 2 TW app and log into registered account automatically. After login, the app will automatically jump to VDP page. VDP Blue LED will turn to steady ON to indicate.
 - 4 After finishing conversation, press the return button to return to camera thumbnail page.

<NOTE>

- ☞ If the Doorbell Notification is not answered within 1 minute after button press, the VDP will time out and the Blue LED will stop spinning
- ☞ When the button is pressed, VDP will take a picture which will be uploaded to the Home Portal Server.

4.4. Video / Picture Capture

VDP will take a picture or video during following occasions. All pictures and video clips taken will be uploaded to the server.

Picture

- Press the function button in front of VDP to take a picture
- Press the camera icon  on the app when streaming video to take a picture

Video

- Press the record video icon  on the app or server webpage UI to record a video
- Whenever an alarm is activated by the Control Panel, VDP will record a video immediately.

5. Programming

VDP setting program should be programmed via Home Portal Server web browser UI.

5.1. Video Setting

Video Setting options are accessed on the Home Portal Server web UI's Camera page.

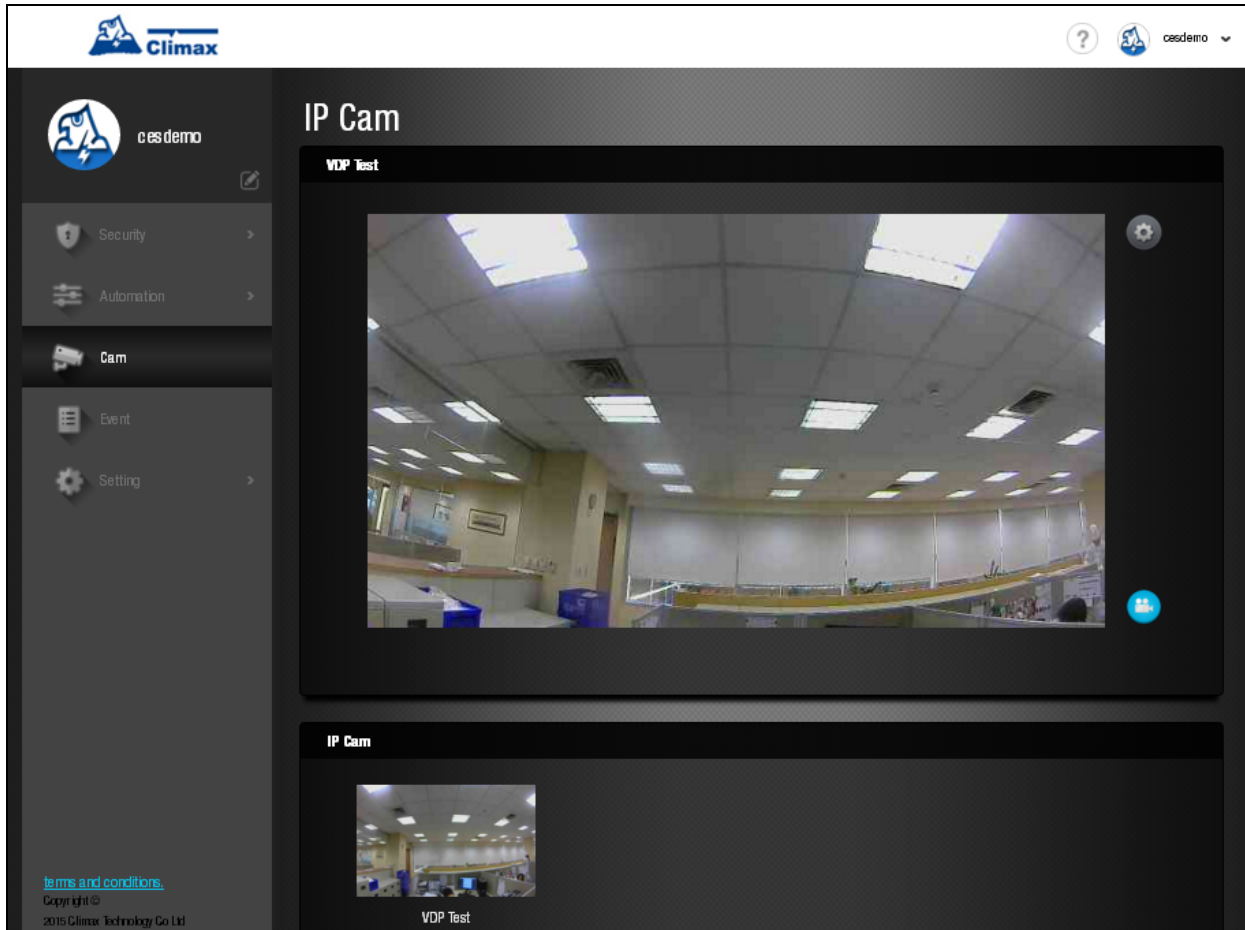

- Press the Video Setting icon  to adjust video configuration:

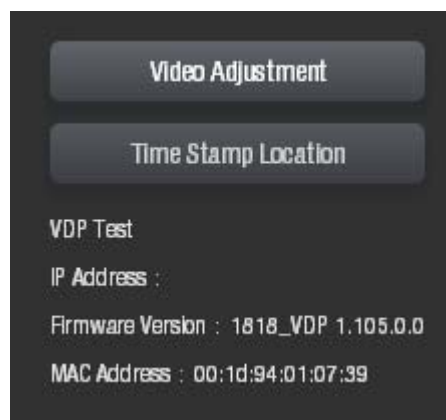

Video Adjustment: For image tuning.

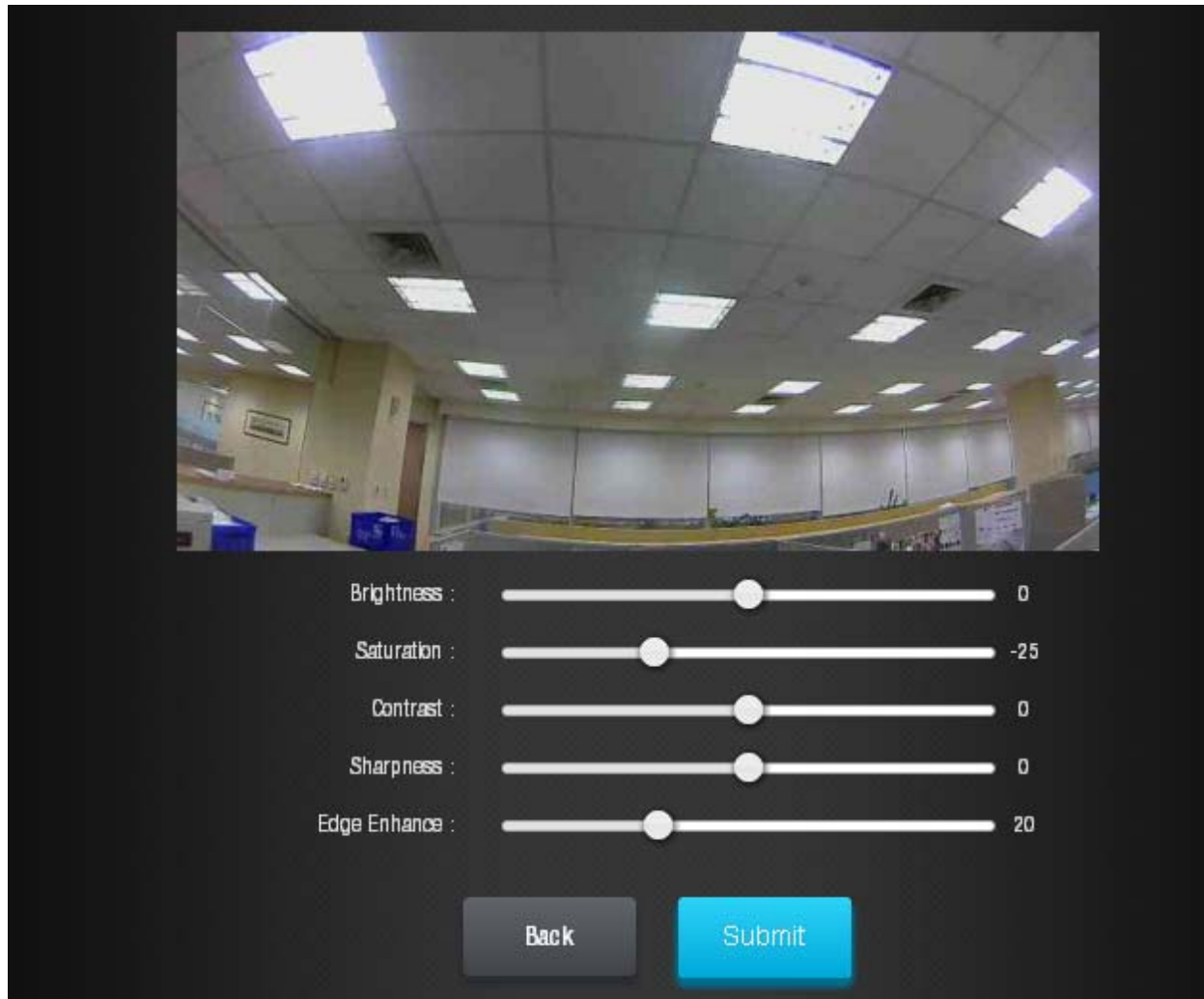

Brightness : 0

Saturation : -25

Contrast : 0

Sharpness : 0

Edge Enhance : 20

Back Submit

Time Stamp: Select the time stamp location on video.



Position :

None

Date Format : Time Format :

- Press the Record icon  to record a video clip

5.2. VDP Setting

VDP's own setting options are accessed on the Home Portal Server web UI's Edit Device page.

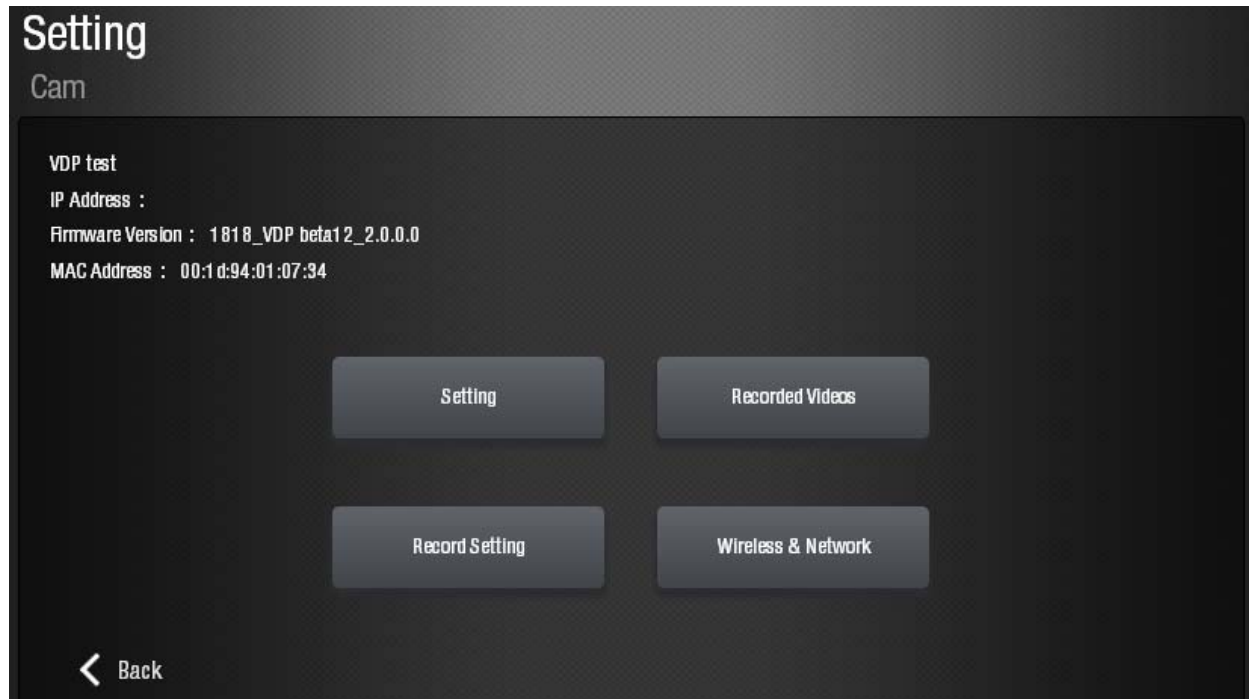

Setting

VDP Test Settings

IP Cam

Area
01

Zone
06

Name
VDP Test

Bypass
Off

Timezone
(GMT+08:00) Beijing, Hong Kong

< Back



Submit

The setting page is used to set VDP zone number, device name and time zone setting. Please refer to your Control Panel's configuration webpage for option detail.

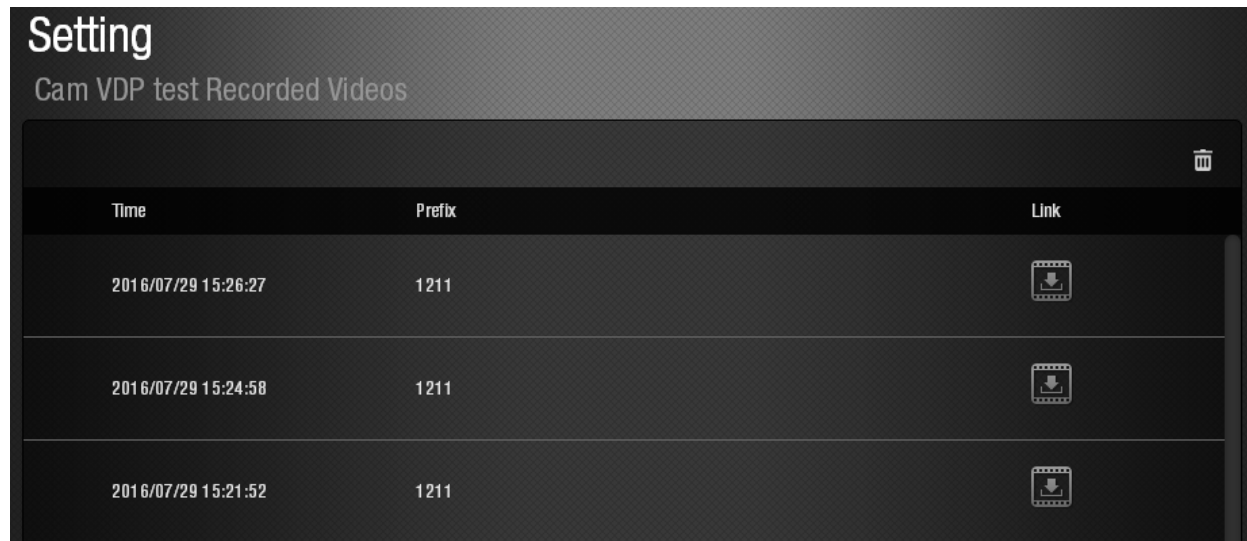
Recorded Video



The screenshot shows a web interface with a dark theme. At the top, the word "Setting" is displayed in a large white font. Below it, the text "Cam VDP test Recorded Videos" is shown in a smaller, lighter font. A table with three columns is visible: "Time", "Prefix", and "Link". Each row in the table contains a timestamp, the number "1211", and a download icon (a film strip with a downward arrow). A trash can icon is located in the top right corner of the table area.

Time	Prefix	Link
2016/07/29 15:26:27	1211	
2016/07/29 15:24:58	1211	
2016/07/29 15:21:52	1211	

The Recorded Video page stores video clips previously taken by VDP for download. Click the download link icon to down the file into your computer.

Recorded Setting

Setting
Cam VDP Test Record Setting

Video Record Length **Reset**

Total Time seconds [MAX: 30secs] Pre-Alarm seconds [MAX: 30secs]

[← Back](#) **Submit**

The Recorded setting page determines the video clip length when VDP is activated to record a video.

- **Total Time:**
The total time length of each recorded video (Default: 30 seconds)The total video time length.
- **Pre-alarm:**
This function is disabled for VDP, please ignore.

Wireless and Network

The screenshot shows a web interface for configuring network settings. At the top, it says "Setting" and "Cam VDP Test Wireless & Network". There are two main sections: "Network" and "Wireless Setting".

Network Section:

- Radio buttons for "Obtain an IP address automatically (DHCP)" (selected) and "Use the following IP address".
- A "DNS Flush Period" dropdown menu set to "Disable".
- A "Reset" button in the top right corner.

Wireless Setting Section:

- Fields for "SSID" (Climax-6F-VIP) and "Pre-shared Key" (masked with dots).
- Dropdown menus for "Authentication Mode" (WPA2 pre-shared key) and "Encryption Type" (AES/CCMP).
- A blue "Scan WiFi APs" button.
- Radio buttons for "Obtain an IP address automatically (DHCP)" (selected) and "Use the following IP address".

The Wireless Network webpage displays current VDP Wi-Fi settings.

Wi-Fi settings can only be changed by factory resetting VDP and using the Vesta Home 2 TW app to reprogram Wi-Fi settings. Wi-Fi settings cannot be changed on the webpage.

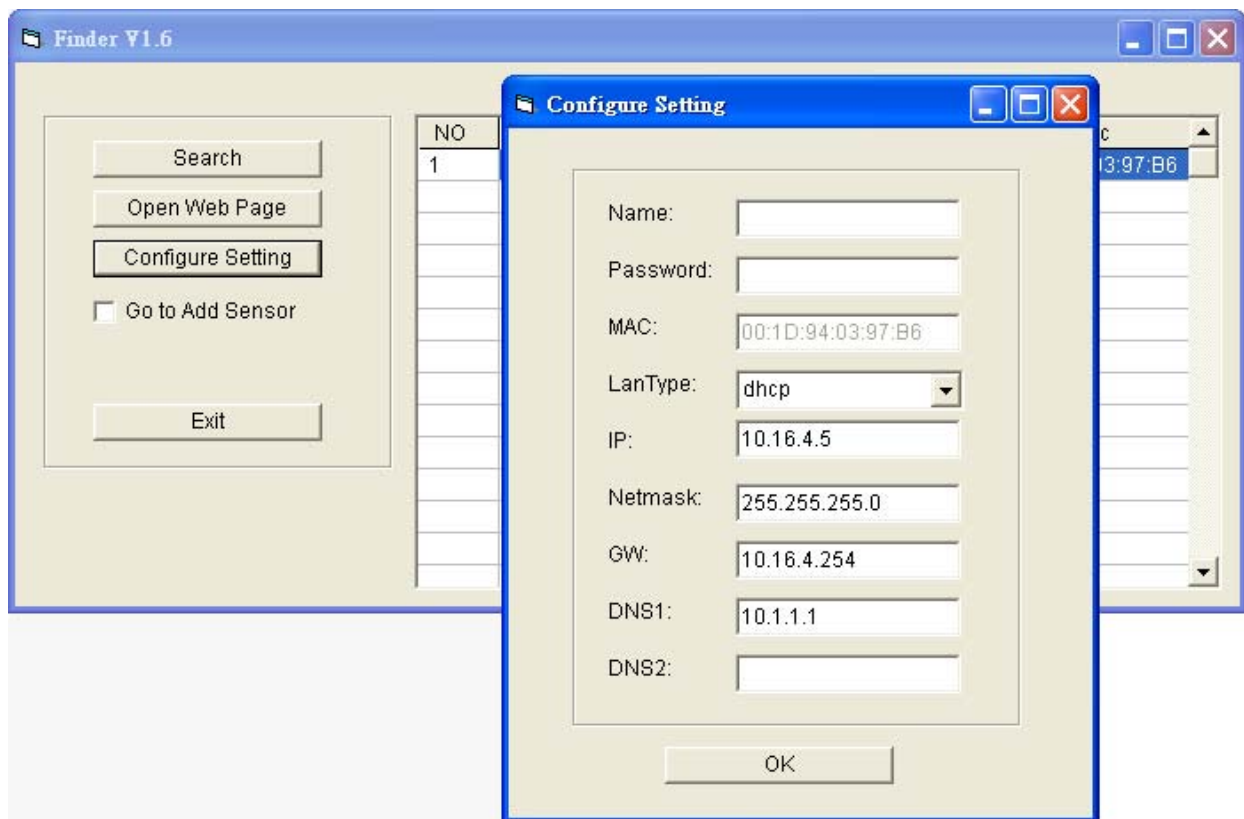

The LanType is default to **DHCP** and does not require manual input of IP/Netmask/Gateawy/DNS setting. If you wish to configure these setting manually, change LanType to **Static**.

After finish changing network setting, enter the user name (default: **admin**) and password (default: **cX+HsA*7F1**) then click **OK** to confirm. The user name and password can be changed later in the camera's configuration webpage

- Step 5.** Click the camera information column and click on **"Open Web Page"**, or double click on the camera column to link to the panel configuration webpage. Your default browser will start automatically to connect to the LAN IP displayed in Finder.

6.1. Connecting to Webpage

If default login user/password is not changed, webpage login will be disabled 1 hour after power on. Please reboot the camera and retry connection.

Step 1. Double click the VDP column on Finder, or enter VDP's LAN IP Address in your browser.

Step 2. Enter the login username and password

Default username: **admin**

Default password: **cX+HsA*7F1**

Step 3. You will enter change password page. Enter and repeat a new password (username change is optional), take care that both username and password are case sensitive. Click OK to confirm.

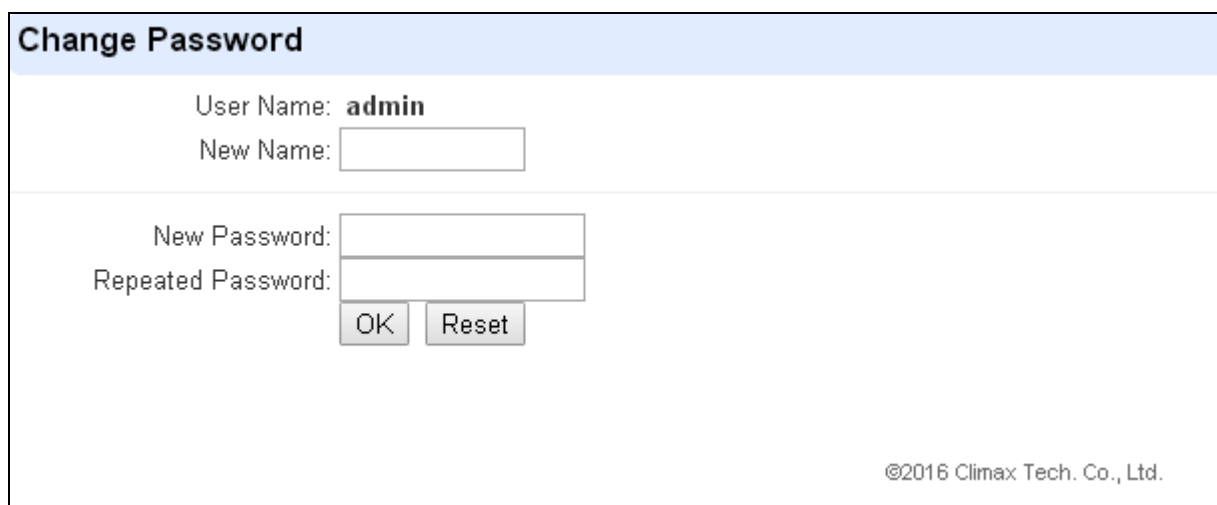

The screenshot shows a web interface titled "Change Password". It has a light blue header. Below the header, there are input fields for "User Name" (pre-filled with "admin"), "New Name" (empty), "New Password", and "Repeated Password". At the bottom of the form are "OK" and "Reset" buttons. The footer contains the copyright notice "©2016 Climax Tech. Co., Ltd."

Step 4. Upon confirming new username and password. You will enter camera Welcome page. The camera will prompt you to re login with new username and password.



The screenshot shows the "Welcome to VDP!" page. It features the Climax logo in the top left. On the left side, there is a navigation menu with links: Home, Event Log, Reported Events, IP Camera, Network Setting, System Setting, Logout, and Reboot. The main content area displays the following information:

- Firmware revision: 1818_VDP beta12_2.0.0.0
- Public IP Address: 1.1
- Internal IP Address: 192.168.1.150
- MAC Address: 00:1D:94:01:07:34

The footer contains the copyright notice "©2014 Climax Tech. Co., Ltd."

The Welcome page displays camera info. Click on the pages and folders on the left to access the camera's various functions

7. IP Camera

The “IP Camera” folder on the left panel includes configuration webpages for you to manage your VDP and view videos.

7.1. Image Tuning

Click on “Image Tuning” to adjust video preferences according to the below parameters:

The screenshot shows the Climax web interface for IP camera configuration. On the left is a navigation tree with the following items: Home, Event Log, Reported Events, IP Camera (expanded), Image Tuning (highlighted with a red box), Time Stamp, Stream Setting, Recorded Video, Alarm Setting, Network Setting, System Setting, Logout, and Reboot. The main content area is titled "Image Tuning" and features a live video feed of an office interior. Below the video are five sliders for image adjustment: Brightness (0), Saturation (-25), Contrast (0), Sharpness (0), and Edge Enhance (20). A "Default" button is located at the bottom of the sliders.

7.2. Time Stamp

The “**Tim Stamp**” webpage is for you to edit the Time Stamp format and location on the video.

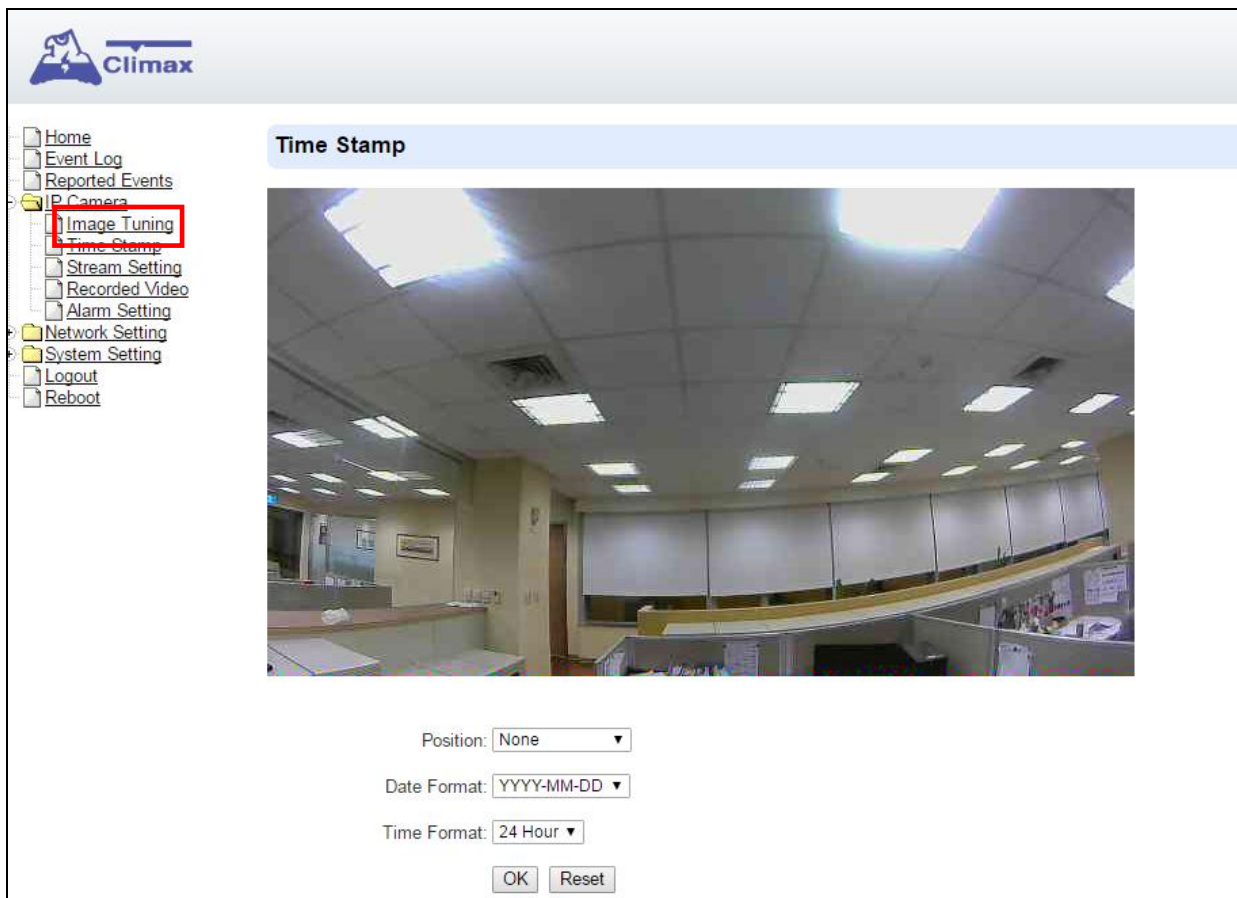

Position

The available options are:

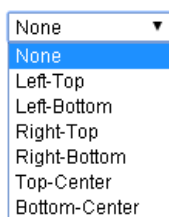

Date Format

The available options are:

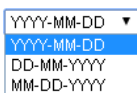

Time Format

The available options are:

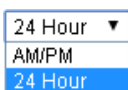

Press “**OK**” to submit your adjusted parameters. Press “**Reset**” to re-select the parameters.

7.3. Stream Setting

The “**Stream Setting**” webpage determines quality of video streaming, and the port to be used when VDP is access remotely via Port Forwarding.

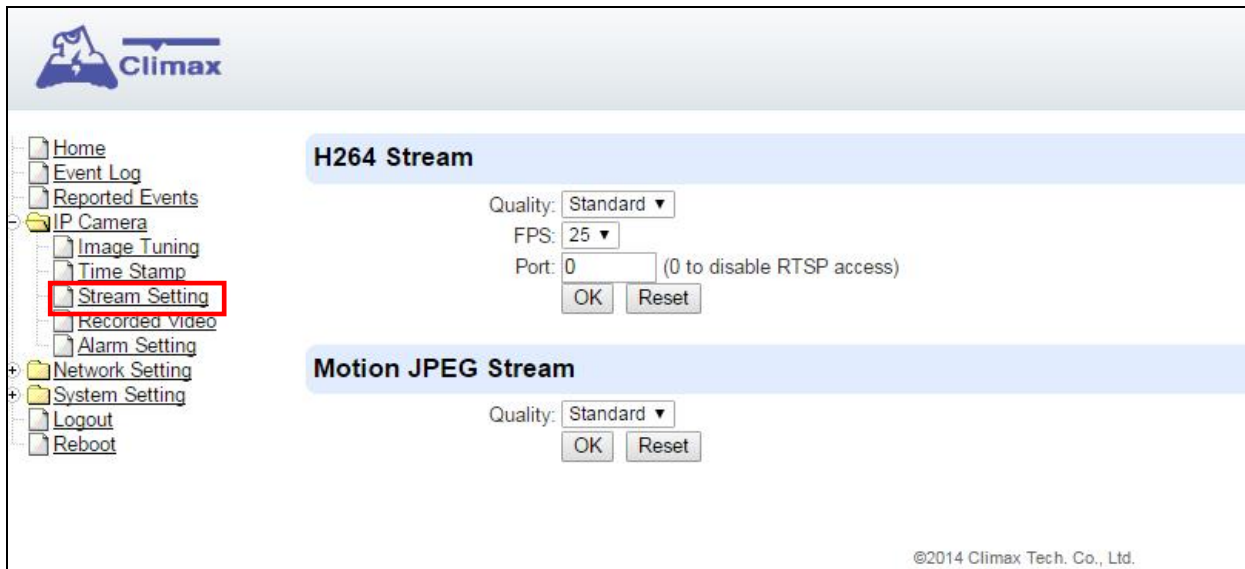

H264 Stream

Quality adjusts the quality of the stream.

Frames Per Second (FPS) are adjustable. Increasing FPS improves the quality of the live-stream. Click “**OK**” to confirm changes or click “**Reset**” to reset to the previously set parameters.

Port: The port number for obtaining HD 1280x720 resolution H264 video stream. The factory default is set to **0** and RTST access is disabled. To enable RTSP function, please set a port number.

Motion JPEG Stream

Quality adjusts the quality of the stream.

7.4. Recorded Files

This menu displays all the recorded files. The VDP has 20 mega-byte storage space for recorded video clips. The video files are stored in the camera's RAM memory and will be cleared if the camera is powered down.

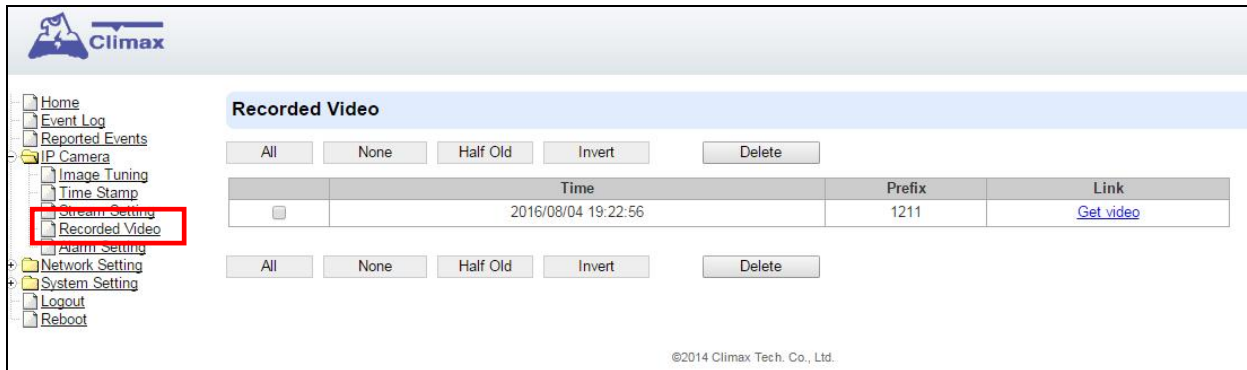

Click on the buttons for the respective functions described below:

- **All:** to select all the recorded videos.
- **None:** to cancel selecting the recorded videos.
- **Half Old:** to select the older half the recorded videos.
- **Invert:** to invert the current selection. E.g. if “**All**” was selected, clicking “**Invert**” will clear all selections.
- **Delete:** to delete the currently selected (ticked) video.
- **Video link:** to download or play the video.

7.5. Alarm Setting

This menu displays the video recording options.

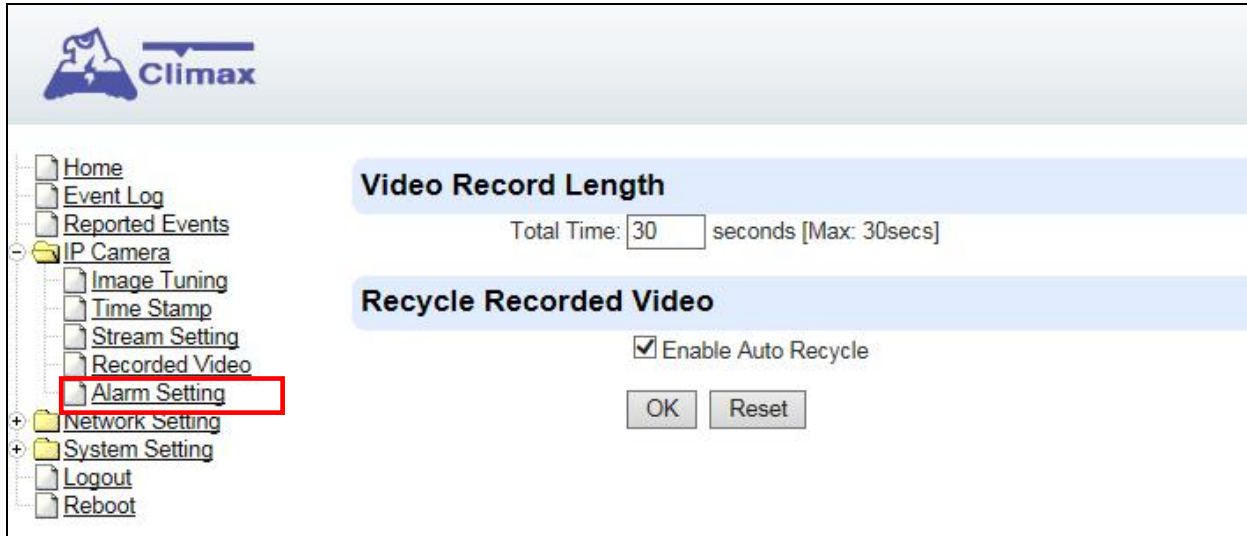

Video Record Length settings

Total Time: The total time length of each recorded video (Default: 30 seconds).

Recycle Recorded Video

When this option is enabled, VDP will automatically delete the oldest videos to clear storage space in the camera when the memory is full

- Press “OK” to submit the updated programmed parameters. Or press “Reset” to re-enter (“Reset” button resets the parameters to the previously set parameters).

8. Network Setting

8.1. Network

The following is displayed when you click on “**Network**” under the “**Network Setting**” option:

The screenshot displays the Climax Network Setting interface. On the left, a sidebar lists various system settings, with 'Network Setting' expanded and 'Network' highlighted. The main area is titled 'Network' and features two radio buttons: 'Obtain an IP address automatically (DHCP)' (selected) and 'Use the following IP address'. Below these are input fields for IP Address (192.168.1.100), Subnet Mask (255.255.255.0), Default Gateway (192.168.1.1), Default DNS 1 (8.8.8.8), and Default DNS 2 (8.8.4.4). A 'DNS Flush Period' dropdown is set to 'Disable'. There are 'OK' and 'Reset' buttons. Below the Network section is the 'Web Server' section with a 'Web Server Port' input field set to '80' and 'OK' and 'Reset' buttons.

- **Obtain an IP address automatically (DHCP)**

If DHCP is selected, the Network will obtain an IP address automatically with a valid Network DHCP Server. Therefore, manual settings are not required.

This is only to be chosen if your Network environment supports DHCP. It will automatically generate all information.

- **Use following IP address**

You can also enter the Network information manually for IP Address, Subnet Mask, Default Gateway, Default DNS 1 and Default DNS 2.

- **DNS Flush Period**

You can set the system to clear current DNS resolution records for all entered URL settings (Reporting, Upload, XMPP...etc.) after a set time period. The system will then resolve the Domain Name again and acquire new IP address for the URL settings. This function is disabled by default.

- **Web Server**

Set the port used to access VDP’s webpage. VDP will reset upon changing the web server port. After reset is complete, VDP will switch to using the new port number when opening its webpage.

8.2. Wireless

The “**Wireless**” webpage display current VDP Wi-Fi setting.

Wi-Fi setting can only be changed by factory resetting VDP and using Vesta Home 2 TW app to reprogram Wi-Fi setting. Wi-Fi setting cannot be changed on the webpage.

Wireless Setting

SSID: Climax-6F-VIP
Signal Status: Link=93/100 Level=70/100

Authentication Mode: WPA2 pre-shared key
Pre-shared Key: ●●●●●●●●
Encryption Type: AES/CCMP

Scan WiFi AP...

Obtain an IP address automatically (DHCP)
 Use the following IP address

IP Address	192	168	1	200
Subnet Mask	255	255	255	0
Default Gateway	192	168	1	1
Default DNS 1	8	8	8	8
Default DNS 2	8	8	4	4

OK Reset

8.3. UPnP

The following is displayed when you click on “UPnP”

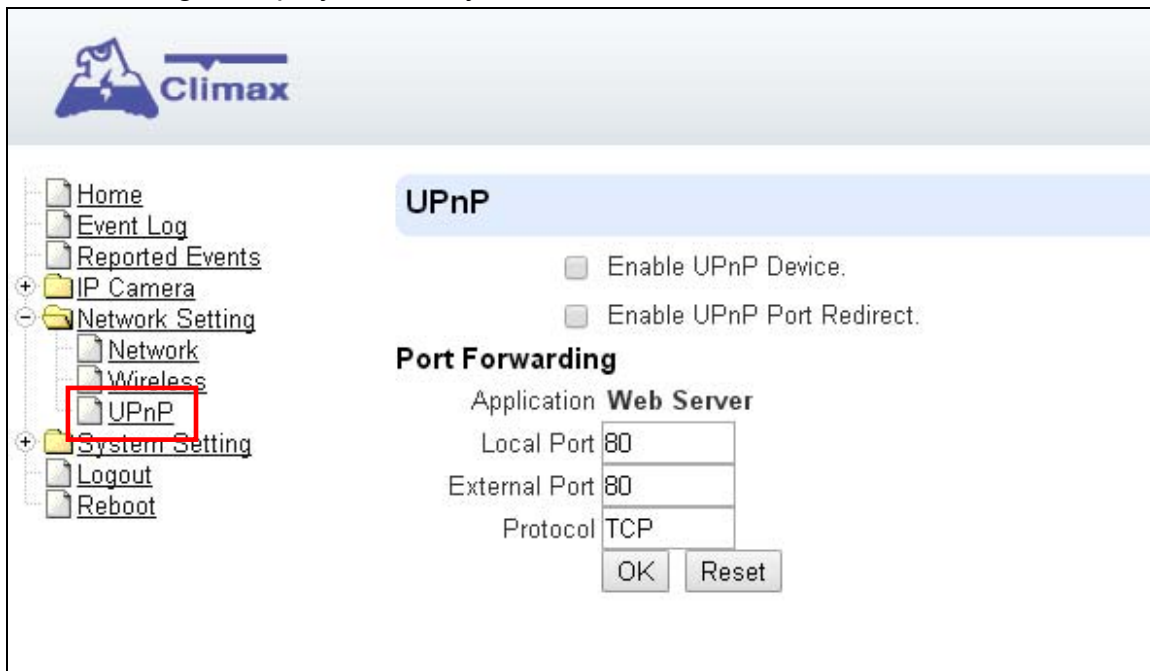

UPnP stands for Universal Plug and Play, which opens network architecture that leverages TCP/IP and the web technologies to enable seamless proximity networking in addition to control and data transfer among networked devices at home, office or public spaces. You can configure this setting to allow for Port Forwarding connection to VDP

- **Enable UPnP Device:**

When enabled, you will be able to see this device via any UPnP discovery tool

- **Enable UPnP Port Redirect:**

The device will try to find an UPnP-supported router and set up the port to redirect to the router.

- **Port Forwarding:**

1. **Local Port**
2. **External Port**
3. **Protocol**

9. System Setting

9.1. Change Password

Edit the username and password used to log into VDP webpage under “**Change Password**” page.

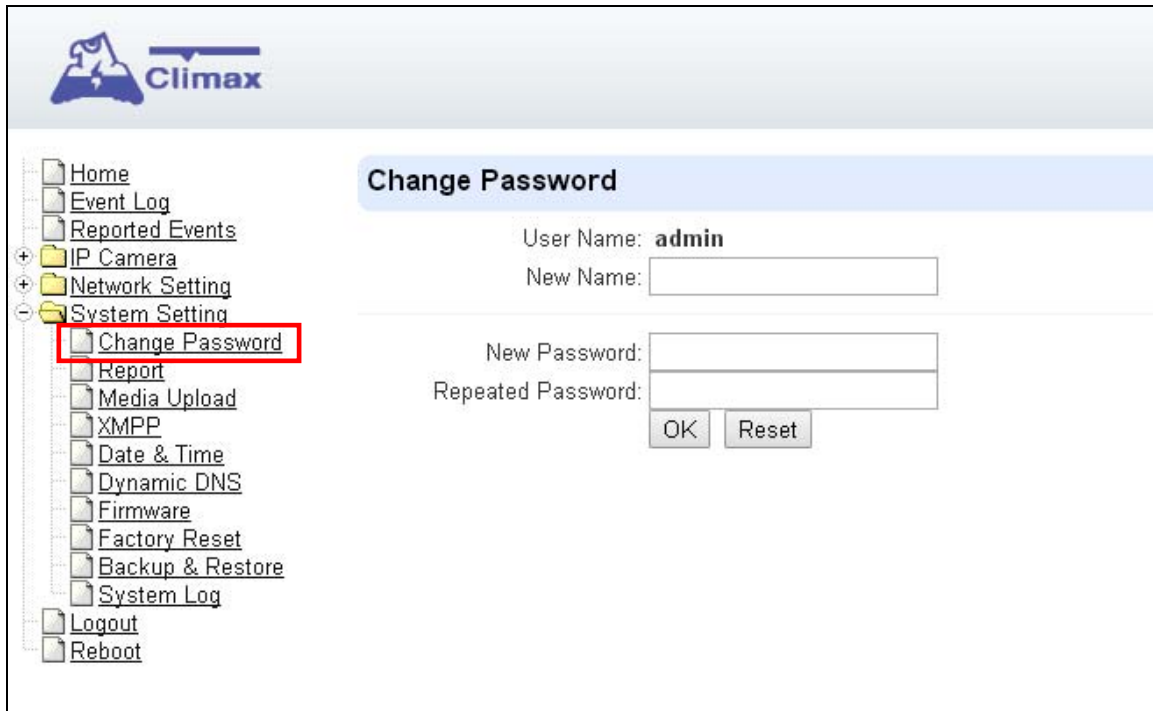

The screenshot shows the Climax web interface. On the left is a navigation tree with the following items: Home, Event Log, Reported Events, IP Camera, Network Setting, System Setting (expanded), Change Password (highlighted with a red box), Report, Media Upload, XMPP, Date & Time, Dynamic DNS, Firmware, Factory Reset, Backup & Restore, System Log, Logout, and Reboot. The main content area is titled 'Change Password' and contains the following form fields: 'User Name: admin', 'New Name: [input field]', 'New Password: [input field]', and 'Repeated Password: [input field]'. At the bottom of the form are 'OK' and 'Reset' buttons.

Enter a new name or new password and click “**OK**” to confirm the username and password change. The username and password are case sensitive.

9.2. Report

The report function for VDP is reserved for use.

The screenshot shows the Climax web interface. On the left is a sidebar menu with the following items: Home, Event Log, Reported Events, IP Camera, Network Setting, System Setting (expanded), Change Password, Report (highlighted with a red box), Media Upload, XMPP, Date & Time, Dynamic DNS, Firmware, Factory Reset, Backup & Restore, System Log, Logout, and Reboot. The main content area is titled 'Report' and contains a table with 20 rows and 6 columns: '#', 'Reporting URL', 'Group 1', 'Group 2', 'Group 3', 'Group 4', and 'Group 5'. Each row has a radio button in the 'Group' columns. Below the table are two rows of dropdown menus for 'Essential' and '99 Retry' settings. At the bottom, there is a note: 'Note: 1. Report via IP (Ethernet or GPRS) in CID format, ex: ip://ACCT@server:port/CID' and two buttons: 'OK' and 'Reset'.

#	Reporting URL	Group 1	Group 2	Group 3	Group 4	Group 5
1		<input type="radio"/>	<input type="radio"/>	<input type="radio"/>	<input type="radio"/>	<input type="radio"/>
2		<input type="radio"/>	<input type="radio"/>	<input type="radio"/>	<input type="radio"/>	<input type="radio"/>
3		<input type="radio"/>	<input type="radio"/>	<input type="radio"/>	<input type="radio"/>	<input type="radio"/>
4		<input type="radio"/>	<input type="radio"/>	<input type="radio"/>	<input type="radio"/>	<input type="radio"/>
5		<input type="radio"/>	<input type="radio"/>	<input type="radio"/>	<input type="radio"/>	<input type="radio"/>
6		<input type="radio"/>	<input type="radio"/>	<input type="radio"/>	<input type="radio"/>	<input type="radio"/>
7		<input type="radio"/>	<input type="radio"/>	<input type="radio"/>	<input type="radio"/>	<input type="radio"/>
8		<input type="radio"/>	<input type="radio"/>	<input type="radio"/>	<input type="radio"/>	<input type="radio"/>
9		<input type="radio"/>	<input type="radio"/>	<input type="radio"/>	<input type="radio"/>	<input type="radio"/>
10		<input type="radio"/>	<input type="radio"/>	<input type="radio"/>	<input type="radio"/>	<input type="radio"/>
11		<input type="radio"/>	<input type="radio"/>	<input type="radio"/>	<input type="radio"/>	<input type="radio"/>
12		<input type="radio"/>	<input type="radio"/>	<input type="radio"/>	<input type="radio"/>	<input type="radio"/>
13		<input type="radio"/>	<input type="radio"/>	<input type="radio"/>	<input type="radio"/>	<input type="radio"/>
14		<input type="radio"/>	<input type="radio"/>	<input type="radio"/>	<input type="radio"/>	<input type="radio"/>
15		<input type="radio"/>	<input type="radio"/>	<input type="radio"/>	<input type="radio"/>	<input type="radio"/>
16		<input type="radio"/>	<input type="radio"/>	<input type="radio"/>	<input type="radio"/>	<input type="radio"/>
17		<input type="radio"/>	<input type="radio"/>	<input type="radio"/>	<input type="radio"/>	<input type="radio"/>
18		<input type="radio"/>	<input type="radio"/>	<input type="radio"/>	<input type="radio"/>	<input type="radio"/>
19		<input type="radio"/>	<input type="radio"/>	<input type="radio"/>	<input type="radio"/>	<input type="radio"/>
20		<input type="radio"/>	<input type="radio"/>	<input type="radio"/>	<input type="radio"/>	<input type="radio"/>
		Essential	Essential ▼	Essential ▼	Essential ▼	Essential ▼
		99 Retry ▼	99 Retry ▼	99 Retry ▼	99 Retry ▼	99 Retry ▼

Note: 1. Report via IP (Ethernet or GPRS) in CID format, ex: ip://ACCT@server:port/CID

OK Reset

9.3. Media Upload

Program the camera's captured video upload destination under "Media Upload" page.

The screenshot shows the Climax camera's web interface. On the left is a navigation tree with 'Media Upload' selected. The main area is titled 'Media Upload' and contains the following fields:

- URL 1:
- URL 2:
- URL 3:
- URL 4:
- URL 5:
- Prefix:
- Delete events after uploaded.

Note: 1. Upload via HTTP(S) protocol, ex: https://server/path
2. Upload via FTP(S) protocol, ex: ftps://user.password@server/path

Buttons:

©2014 Climax Tech. Co., Ltd.

- **Upload to FTP:** <ftp://user.password@server/path> or <ftps://user.password@server/path>
- **Upload to server:** <http://server/path> or <https://server/path>

After the camera has been learnt into Control Panel, the first upload URL will be programmed automatically according to panel setting. Do NOT change this setting or it will cause video upload to server to fail..

9.4. XMPP

The “XMPP” page allows the camera to connect to the Home Portal™ Server for remote control. Please do not modify any settings or the camera may lose connection with Home Portal Server.

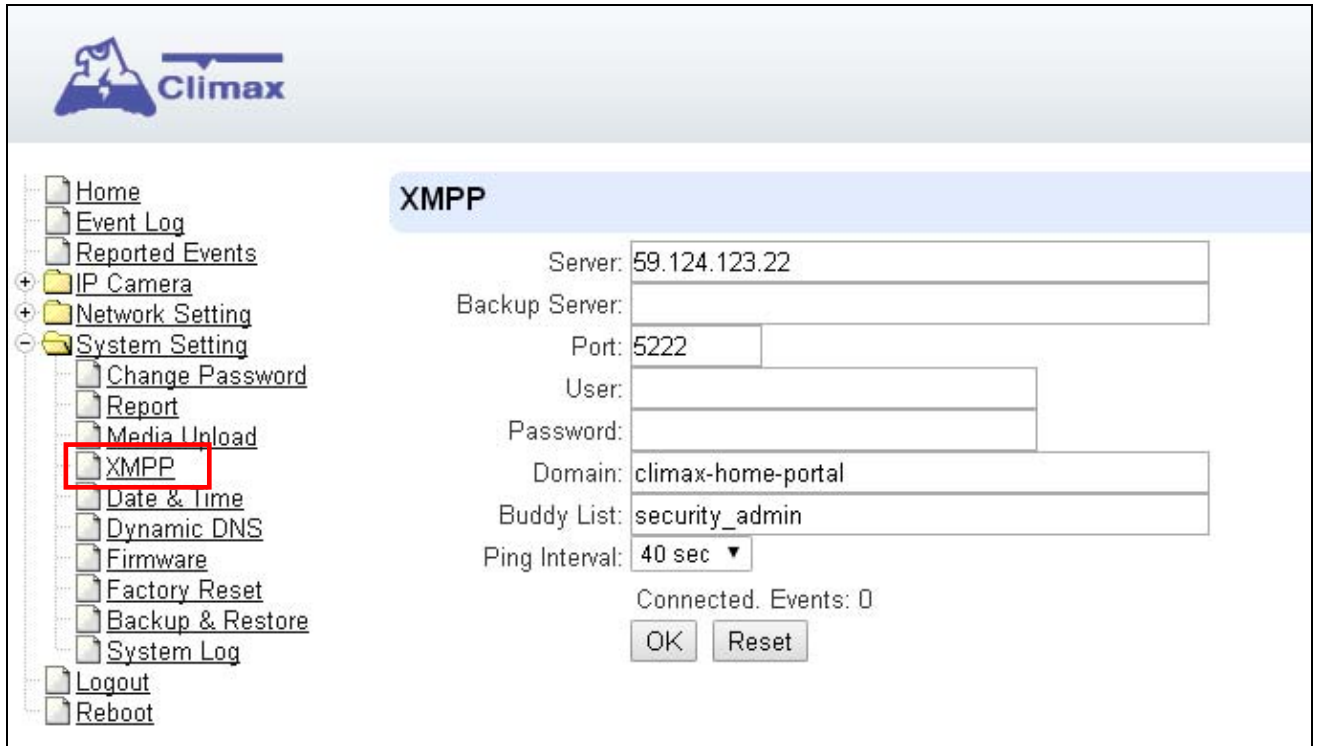

The screenshot displays the XMPP configuration interface. On the left, a navigation tree includes 'System Setting' with 'XMPP' selected. The main panel shows the following settings:

- Server: 59.124.123.22
- Backup Server: (empty)
- Port: 5222
- User: (empty)
- Password: (empty)
- Domain: climax-home-portal
- Buddy List: security_admin
- Ping Interval: 40 sec
- Connected. Events: 0

Buttons for 'OK' and 'Reset' are located at the bottom of the configuration area.

9.5. Date & Time

The following page is displayed when you click on “Date & Time”:

The screenshot shows the Climax web interface. On the left is a sidebar menu with the following items: Home, Event Log, Reported Events, IP Camera, Network Setting, System Setting (expanded), Change Password, Report, Media Upload, YMP, Date & Time (highlighted with a red box), Dynamic DNS, Firmware, Factory Reset, Backup & Restore, System Log, Logout, and Reboot. The main content area is titled 'Date & Time' and contains three sections:

- Date & Time:** A date input field showing '2016/08/05' with a calendar icon and '(yyyy/MM/dd)' format. A time input field showing '13 : 28' with '(hh:mm)' format and a 'Now' button. Below are 'OK' and 'Reset' buttons.
- Time Zone:** A dropdown menu showing '(GMT+08:00) Beijing, Hong Kong, Taipei'. Below are 'OK' and 'Reset' buttons.
- Internet Time:** A checked checkbox labeled 'Automatically synchronize with an Internet time server.' Below is a dropdown menu for 'Server' showing 'time1.google.com'. Below are 'OK' and 'Reset' buttons.

Under the **Date & Time** heading, you can edit time and date. As the page does not automatically refresh itself with the time, you can click on “**Now**” to refresh to your current time.

Under the **Time Zone** heading, you can choose your time zone.

Under the **Internet Time** heading, you can tick the box “Automatically synchronize with an Internet time server” to adjust to internet time. The scroll down bar of “Server” allows you to choose from a selection of time servers.

Click on “**OK**” to confirm the settings.

9.6. Dynamic DNS

The “Dynamic DNS” page provides VDP public IP information.

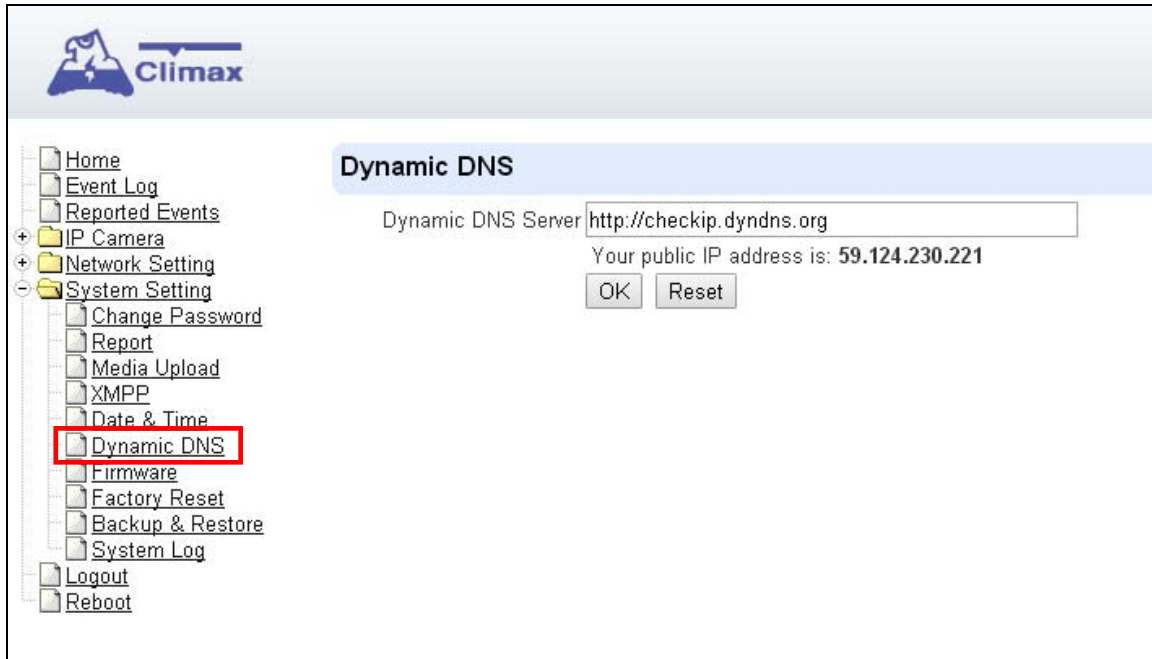

- **Dynamic DNS Server:** Set the server used by VDP to acquire its public IP address.
- **Public IP address:** The public IP address shown is required to for remote access of the VDP via port forwarding.

9.7. Firmware

The following page is displayed when you click on “Firmware”

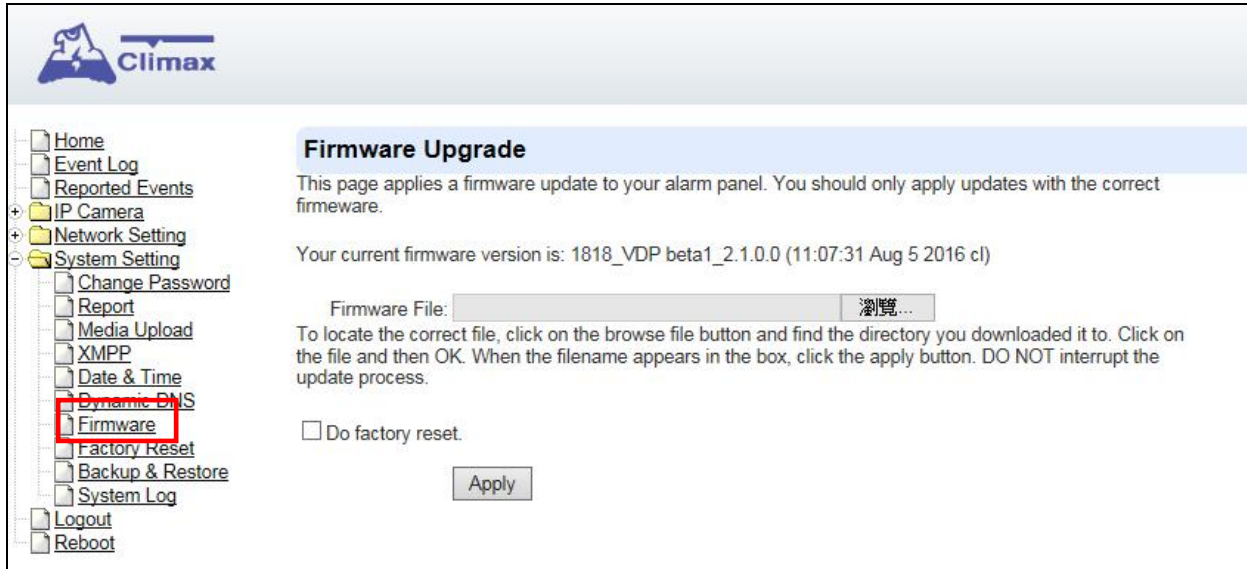

The screenshot shows the Climax web interface. On the left is a navigation menu with the following items: Home, Event Log, Reported Events, IP Camera, Network Setting, System Setting (expanded), Change Password, Report, Media Upload, XMPP, Date & Time, Dynamic DNS, Firmware (highlighted with a red box), Factory Reset, Backup & Restore, System Log, Logout, and Reboot. The main content area is titled "Firmware Upgrade" and contains the following text: "This page applies a firmware update to your alarm panel. You should only apply updates with the correct firmware." Below this, it states "Your current firmware version is: 1818_VDP beta1_2.1.0.0 (11:07:31 Aug 5 2016 cl)". There is a text input field for "Firmware File:" followed by a "瀏覽..." button. Below the input field is a paragraph of instructions: "To locate the correct file, click on the browse file button and find the directory you downloaded it to. Click on the file and then OK. When the filename appears in the box, click the apply button. DO NOT interrupt the update process." At the bottom of the main area, there is a checkbox labeled "Do factory reset." and an "Apply" button.

You can update VDP firmware: Click the “**Choose File**” button, browse and find the correct file, and press “**Apply**” to apply the setting. Please follow the onscreen instruction to complete the update. It is also recommended to select “Do factory reset (recommended)” when upgrading a firmware.

9.8. Factory Reset

Factory Reset function will clear all VDP setting, event records and restore all settings to factory default.



You can choose to reset VDP to the factory default setting by clicking the “**Yes**” button. After factory reset, delete VDP from panel device list, then user the Vesta Home 2 app to setup VDP WiFi and learn VDP into panel again.

Hardware Factory Reset

1. Disconnect and reconnect AC power.
2. Press and hold VDP button as soon as AC power is reconnected. Do NOT wait for warm up to complete.
3. Keep holding the button for about 25 seconds until VDP Amber LED flashes 3 times, then stays ON, then release the button.
4. Factory Reset is complete, VDP will reboot and enter W-Fi setup mode.

9.9. Backup & Restore

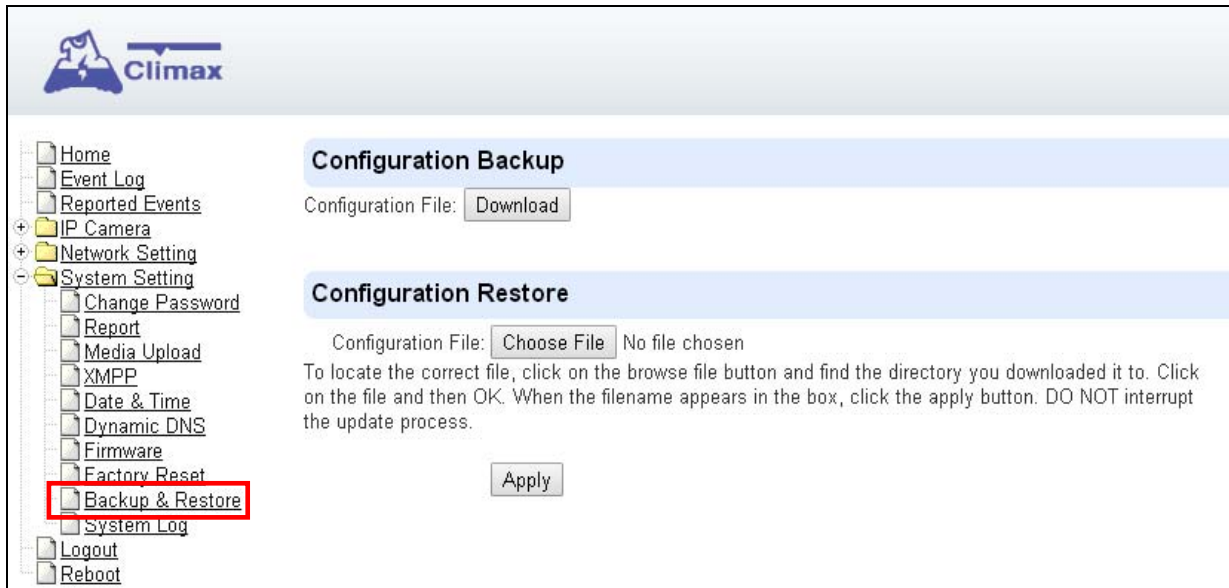

The screenshot displays the Climax web interface. On the left is a navigation menu with items: Home, Event Log, Reported Events, IP Camera, Network Setting, System Setting (expanded), Change Password, Report, Media Upload, XMPP, Date & Time, Dynamic DNS, Firmware, Factory Reset, Backup & Restore (highlighted with a red box), System Log, Logout, and Reboot. The main content area has two sections: 'Configuration Backup' with a 'Download' button, and 'Configuration Restore' with a 'Choose File' button and an 'Apply' button. The restore section includes instructions: 'To locate the correct file, click on the browse file button and find the directory you downloaded it to. Click on the file and then OK. When the filename appears in the box, click the apply button. DO NOT interrupt the update process.'

You can store the current settings by clicking on the **“Download”** button.

If you wish to restore the previously stored file, click on **“Choose File”**, find the correct file and click on **“Apply”** to restore to the previous setting.

9.10. System Log

The “**System Log**” displays system operation history.

You can choose how many reported events are displayed by selecting the drop down bar near the bottom of the page, or click “**Download**” button to download detailed system log file into your computer.

System Log

Reload

Time	Priority	Class	Action	Source	Message
2016/08/05 13:32:34	6	16	Log	XFINDER Client	setparm by 192.168.1.35 mask=0/0
2016/08/05 13:02:34	6	16	Log	XFINDER Client	setparm by 192.168.1.35 mask=0/0
2016/08/05 12:32:34	6	16	Log	XFINDER Client	setparm by 192.168.1.35 mask=0/0
2016/08/05 12:02:33	6	16	Log	XFINDER Client	setparm by 192.168.1.35 mask=0/0
2016/08/05 11:34:08	6	30	Success	Worker	SNTP Setup Time
	3	13	Fail	HTTP Client	checkip.dyndns.org
	4	30	Wireless LAN	Worker	Connected
	6	30	Wireless LAN	Worker	Setup Network Address
	6	30	Ethernet	Worker	Setup Network Address
2016/08/05 11:32:11	6	19	Starting	Upgrader	Upgrading Firmware
2016/08/05 11:26:03	6	30	Success	Worker	SNTP Setup Time
	3	13	Fail	HTTP Client	checkip.dyndns.org
	4	30	Wireless LAN	Worker	Connected
	6	30	Wireless LAN	Worker	Setup Network Address
	6	30	Ethernet	Worker	Setup Network Address
2016/08/05 11:02:32	6	16	Log	XFINDER Client	setparm by 192.168.1.35 mask=0/0
2016/08/05 10:32:32	6	16	Log	XFINDER Client	setparm by 192.168.1.35 mask=0/0
2016/08/05 10:32:19	6	30	Ethernet	Worker	Setup Network Address
2016/08/05 10:32:14	3	18	Fail	XMPP	homeportal.climax.com.tw
2016/08/05 10:32:01	3	18	Fail	XMPP	homeportal.climax.com.tw

Limit # of items:

System Log File:

9.11. Logout

Click “**Logout**” and confirm the action to disconnect from VDP webpage.

9.12. Reboot

The Reboot function allows you to restart the VDP. Press “**Reboot**” and confirm, VDP will automatically start rebooting process and countdown the remaining time.

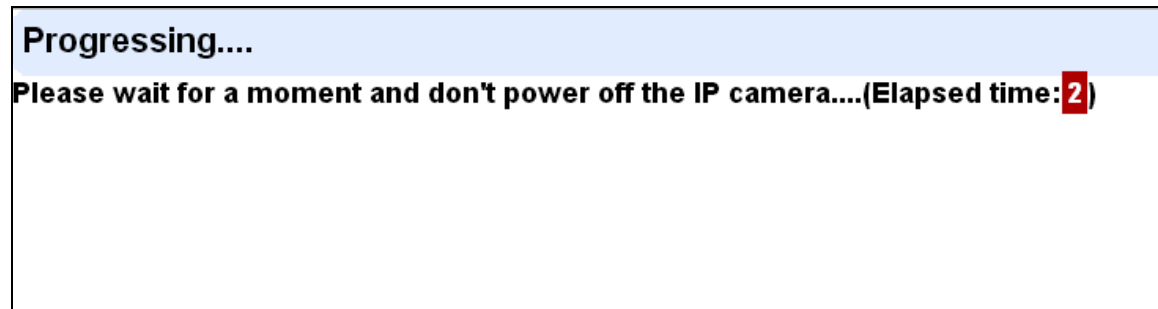

10. History

10.1. Event Log

The Event Log records system events.

Time	Mode	Action	Source	Message
2016/08/04 20:00:06	Normal	Live Video Stream	IPCam	Stop
2016/08/04 19:59:06	Normal	Connect to server	IPCam	Connecting to stream server(59.124.123.22) success
2016/08/04 19:59:05	Normal	Live Video Stream	IPCam	Starting
2016/08/04 19:58:52	Normal	Upload Video	IPCam	Uploaded
2016/08/04 19:58:45	Normal	Dump Video	IPCam	Ready
	Normal	Initialize	Panel	Ready
2016/08/04 19:29:24	Normal	Live Video Stream	IPCam	Stop
2016/08/04 19:28:27	Normal	Upload Video	IPCam	Uploaded
2016/08/04 19:28:11	Normal	Dump Video	IPCam	Ready
2016/08/04 19:26:53	Normal	Request Video	IPCam	XFINDER Client
2016/08/04 19:24:24	Normal	Upload Video	IPCam	Uploaded
2016/08/04 19:24:14	Normal	Dump Video	IPCam	Ready
2016/08/04 19:22:56	Normal	Request Video	IPCam	XFINDER Client
2016/08/04 19:22:52	Normal	Connect to server	IPCam	Connecting to stream server(59.124.123.22) success
2016/08/04 19:22:52	Normal	Live Video Stream	IPCam	Starting
	Normal	Initialize	Panel	Ready
2016/08/04 19:19:10	Normal	Shutdown	Panel	Success
2016/08/04 19:19:09	Normal	Request Reboot	Panel	Web
2016/08/04 19:13:28	Normal	Live Video Stream	IPCam	Stop
2016/08/04 19:13:10	Normal	Dump Video	IPCam	Error: Saving video fail! SD Card space may be not enough.

You can choose how many events are displayed on the page by selecting the drop down bar near the bottom of the page.

10.2. Reported Events

The Reported Event page is reserved.

Time	Area	Zone / User	Trigger / Restore	CID event	Message	Report Status	Comment
No items found							

You can choose how many reported events are displayed by selecting the drop down bar near the bottom of the page.

I. Federal Communication Commission Interference Statement

This equipment has been tested and found to comply with the limits for a Class B digital device, pursuant to Part 15 of the FCC Rules. These limits are designed to provide reasonable protection against harmful interference in a residential installation.

This equipment generates, uses and can radiate radio frequency energy and, if not installed and used in accordance with the instructions, may cause harmful interference to radio communications. However, there is no guarantee that interference will not occur in a particular installation. If this equipment does cause harmful interference to radio or television reception, which can be determined by turning the equipment off and on, the user is encouraged to try to correct the interference by one of the following measures:

- . Reorient or relocate the receiving antenna.
- . Increase the separation between the equipment and receiver.
- . Connect the equipment into an outlet on a circuit different from that to which the receiver is connected.
- . Consult the dealer or an experienced radio/TV technician for help.

FCC Caution: To assure continued compliance, any changes or modifications not expressly approved by the party responsible for compliance could void the user's authority to operate this equipment. (Example - use only shielded interface cables when connecting to computer or peripheral devices).

FCC Radiation Exposure Statement

This equipment complies with FCC RF radiation exposure limits set forth for an uncontrolled environment. This equipment should be installed and operated with a minimum distance of 20 centimeters between the radiator and your body.

This transmitter must not be co-located or operating in conjunction with any other antenna or transmitter.

The antennas used for this transmitter must be installed to provide a separation distance of at least 20 cm from all persons and must not be co-located or operating in conjunction with any other antenna or transmitter.

This device complies with Part 15 of the FCC Rules. Operation is subject to the following two conditions:

- (1) This device may not cause harmful interference, and
- (2) This device must accept any interference received, including interference that may cause undesired operation.