

TEST REPORT

Product Name : WIRELESS CHARGING ALARM CLOCK
: RADIO WITH SPEAKER AND DUAL USB
: CHARGING

Model Number : iBTW282, iBTW282X (X could be single or
: multiple digits by any alphabets and
: punctuation marks denoting different year
: version, buyers and cabinet colors)

FCC ID : EMOIBTW282A

Prepared for : SDI Technologies Inc.
Address : 1299 Main Street, Rahway, NJ 07065, U.S.A

Prepared by : EMTEK (SHENZHEN) CO., LTD.
Address : Building 69, Majialong Industry Zone, Nanshan District,
: Shenzhen, Guangdong, China

TEL:(0755) 26954280
FAX:(0755) 26954282

Report Number : ENS2505160048W01102R
Date of sample receipt : Apr 25, 2025
Date(s) of Tests : Apr 25, 2025 to May 19, 2025
Date of issue : May 20, 2025

TABLE OF CONTENT

Test Report Description	Page
1. TEST REPORT DESCRIPTION	3
2. GENERAL INFORMATION	5
2.1. Description of Device (EUT)	5
2.2. Input / Output Ports	5
2.3. Independent Operation Modes	6
2.4. Test Manner	6
2.5. Description of Test Facility	6
2.6. Description of Support Device	6
2.7. Measurement Uncertainty	7
3. SUMMARY OF TEST RESULTS	7
4. MEASURING DEVICE AND TEST EQUIPMENT	9
5. 20DB BANDWIDTH	9
5.1. Test Procedure	10
5.2. Test Results	10
6. POWER LINE CONDUCTED EMISSION MEASUREMENT	11
6.1. Block Diagram of Test Setup	11
6.2. Limits	11
6.3. Test Procedure	11
6.4. Measuring Results	12
7. RADIATED EMISSION TEST	15
7.1. Measurement Procedure	15
7.2. Test SET-UP (Block Diagram of Configuration)	15
7.3. Radiated Emission Limit	16
7.4. Measurement Result	17
8. ANTENNA REQUIREMENT	20

1. TEST REPORT DESCRIPTION

Applicant : SDI Technologies Inc.
 Address : 1299 Main Street, Rahway, NJ 07065, U.S.A
 Manufacturer : SDI Technologies Inc.
 Address : 1299 Main Street, Rahway, NJ 07065, U.S.A
 EUT : WIRELESS CHARGING ALARM CLOCK RADIO WITH SPEAKER AND DUAL USB CHARGING
 Model Name : iBTW282, iBTW282X (X could be single or multiple digits by any alphabets and punctuation marks denoting different year version, buyers and cabinet colors)
 Trademark : iHome

Measurement Procedure Used:

APPLICABLE STANDARDS	
STANDARD	TEST RESULT
FCC 47 CFR Part 2, Subpart J FCC 47 CFR Part 15, Subpart C	PASS

The above equipment was tested by EMTEK (SHENZHEN) CO., LTD. The test data, data evaluation, test procedures, and equipment configurations shown in this report were made in accordance with the procedures given in ANSI C63.10 (2013) and the energy emitted by the sample EUT tested as described in this report is in compliance with conducted and radiated emission limits of FCC Rules Part 15C

The test results of this report relate only to the tested sample identified in this report.

Date of Test : Apr 25, 2025 to May 19, 2025

Prepared by : Una Yu
 Una Yu /Editor

Reviewer : Joe Xia
 Joe Xia/Supervisor

Approve & Authorized Signer : Lisa Wang
 Lisa Wang/Manager



Modified History

Version	Report No.	Revision Date	Summary
	ENS2505160048W01102R	/	Original Report



2. GENERAL INFORMATION

2.1. Description of Device (EUT)

Characteristics	Description
Product Name	WIRELESS CHARGING ALARM CLOCK RADIO WITH SPEAKER AND DUAL USB CHARGING
Model number	iBTW282, iBTW282X (X could be single or multiple digits by any alphabets and punctuation marks denoting different year version, buyers and cabinet colors) (Note: These models are the same, except for the model names, year version, buyers and cabinet color;iBTW282 was selected for full test.)
Power Supply	DC 9V from Adapter Adapter:Model:XY-CA03600900330U01 INPUT:100-240V~50/60Hz 0.95A Max Output:9V= 3.3A
Operating Frequency Range	111KHz-205KHz
Modulation Technique	FSK
Wireless Output Power	5W/9W/15W
Antenna1 Type	Induction Coil antenna
Temperature Range	-10°C ~ +45°C

2.2. Input / Output Ports

Port #	Name	Type*	Cable Max. >3m	Cable Shielded	Comments
1	Enclosure	N/E	--	--	None
2	DC IN port	I/O	No	Unshielded	1 port
3	USB port	DC	No	Unshielded	1 port
<p>* Note: For the purposes of the present document, the following symbols apply:</p> <p>AC AC Power Port DC DC Power Port N/E Non-Electrical I/O Signal Input or Output Port (Not Involved in Process Control) TP Telecommunication Ports</p>					

2.7. Measurement Uncertainty

Test Parameter	Measurement Uncertainty
Frequency error	±20Hz
Occupied Bandwidth	±0.5KHz
Transmitter output power	±0.6dB
Conducted spurious emissions	±3.2dB
Radiated spurious emissions	±4.5dB
Temperature	±1.2°C
Humidity	±3%
DC voltages	±0.25V
Time	±1%



3. SUMMARY OF TEST RESULTS

EMISSION		
Description of Test Item	Standard & Limits	Results
Conducted Emission	FCC Part 15, Subpart C- Section 15.207 ANSI C63.10-2013	Pass
Radiated Emission	FCC Part 15, Subpart C- Section 15.209 ANSI C63.10-2013	Pass
Note: N/A is an abbreviation for Not Applicable.		



4. MEASURING DEVICE AND TEST EQUIPMENT

Conducted Emission Test Equipment

Equipment	Manufacturer	Model No.	Serial No.	Last Cal.	Cal. Interval
EMI Test Receiver	Rohde & Schwarz	ESCI	101384	2024/05/11 2025/5/9	1 Year
AMN	Rohde & Schwarz	ENV216	101161	2024/05/10 2025/5/9	1 Year

For Spurious Emissions Test

Equipment	Manufacturer	Model No.	Serial No.	Last Cal.	Cal. Interval
EMI Test Receiver	Rohde & Schwarz	ESU 26	100154	2024/5/10 2025/5/9	1Year
Pre-Amplifie	Lunar EM	LNA30M3G-25	J10100000070	2024/5/10 2025/5/9	1Year
Bilog Antenna	Schwarzbeck	VULB9163	661	2023/6/2 2025/5/18	2 Year
Horn antenna	Schwarzbeck	BBHA9120D	9120D-1177	2023/5/12 2025/5/17	2 Year
Pre-Amplifie	SKET	LNPA_0118G-45	SK2019051801	2024/5/10 2025/5/9	1Year
Loop Antenna	Schwarzbeck	FMZB1519	1519-012	2023/5/12 2025/5/13	2Year
Spectrum Analyzer	Rohde & Schwarz	FSV40	100967	2024/5/10 2025/5/9	1Year
Horn antenna	Schwarzbeck	BBHA9170	9170-399	2023/5/12 2025/5/13	2Year
Coaxial Cable	TIMES	NmNm-7-C15702	N/A	2024/5/23	1Year
Coaxial Cable	TIMES	HF290-NM5M-6.5M	N/A	2024/5/23	1Year
Coaxial Cable	TIMES	LMR-240 N-N	N/A	2024/5/23	1Year

For other test items:

Equipment	Manufacturer	Model No.	Serial No.	Last Cal.	Cal. Interval
Signal Analyzer	Agilent	N9010A	MY53470879	2024/5/10 2025/5/10	1Year
Vector Signal Generater	Agilent	N5182B	MY53050878	2024/5/10 2025/5/10	1Year
Analog Signal Generator	Agilent	N5171B	MY53050553	2024/5/10 2025/5/10	1Year
RF Control Unit(Power Meter)	Tonscend	JS0806-2	\	2024/5/10 2025/5/10	1Year
Temperature&Humidity Chamber	ESPEC	EL-02KA	12107166	2024/5/10 2025/5/10	1Year

5. 20DB BANDWIDTH

5.1. Test Procedure

Set to the maximum power setting and enable the EUT transmit continuously
 Set RBW = 100Hz.
 Set the video bandwidth (VBW) =300Hz.
 Set Span= 800Hz
 Set Detector = Peak.
 Set Trace mode = max hold.
 Set Sweep = auto couple.
 Measure and record the results in the test report.

5.2. Test Results

Temperature: 25.2°C Test Date: 2025.05.16
 Humidity: 55.7 % Test By: Calvin
 20dB Band=248.9 Hz

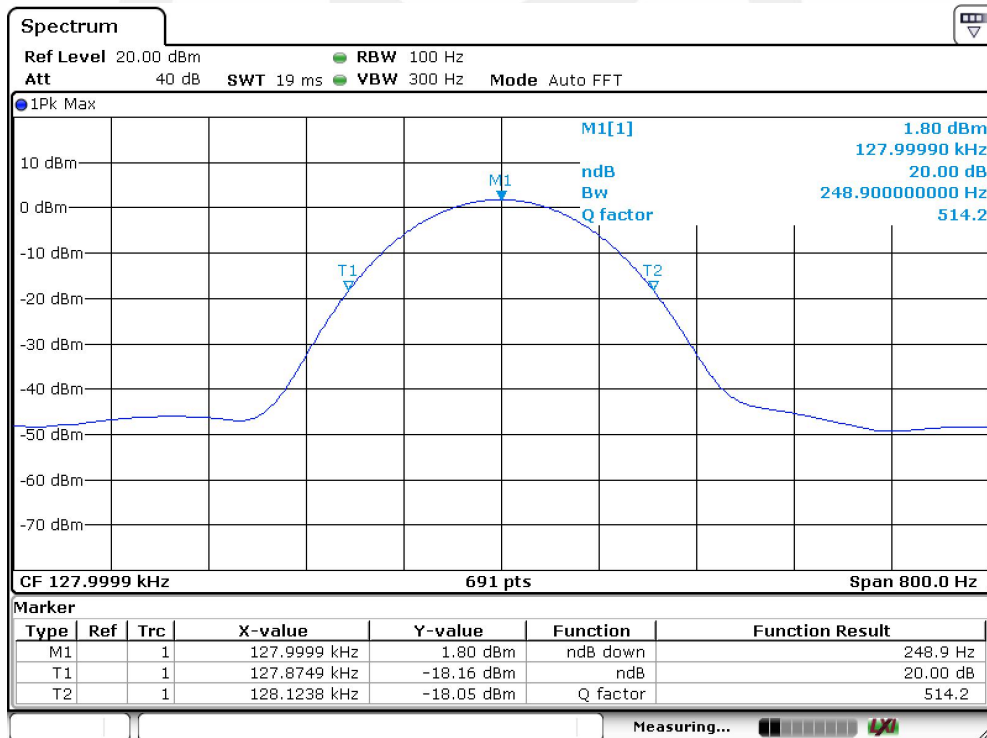

6. POWER LINE CONDUCTED EMISSION MEASUREMENT

6.1. Block Diagram of Test Setup

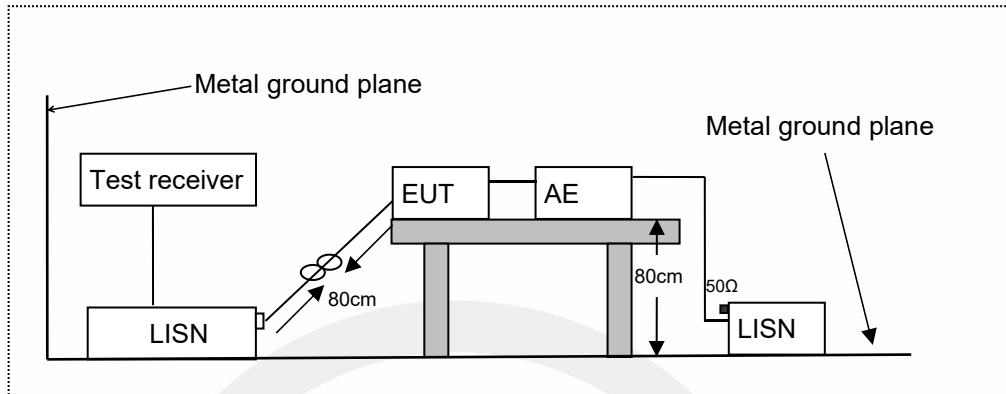

LISN: Line Impedance Stabilization Network
 AE: Associated equipment
 EUT: Equipment under test

6.2. Limits

FCC Part 15.207

Frequency (MHz)	Limit (dB μ V)	
	Quasi-peak Level	Average Level
0.15 ~ 0.50	66.0 ~ 56.0 *	56.0 ~ 46.0 *
0.50 ~ 5.00	56.0	46.0
5.00 ~ 30.00	60.0	50.0

NOTE1-The lower limit shall apply at the transition frequencies.
 NOTE2-The limit decreases linearly with the logarithm of the frequency in the range 0.15MHz to 0.50MHz.

6.3. Test Procedure

The EUT was placed on a desk 0.8 m height from the metal ground plane and 0.4 m from the conducting wall of the shielding room and it was kept at least 0.8 m from any other grounded conducting surface. The size of the table will nominally be 1.5 m x1.0 m.

The rear of the arrangement shall be flush with the back of the supporting tabletop unless that would not be possible or typical of normal use.

All units of equipment forming the system under test (includes the EUT as well as connected peripherals and associated equipment or devices) shall be arranged such that a nominal 0.1 m separation is achieved between the neighboring units.

Connect EUT to the power mains through a line impedance stabilization network (LISN). Where the mains cable supplied by the manufacturer is longer than 1 m, the excess should be folded at the centre into a bundle no longer than 0.4 m, so that its length is shortened to 1 m.

All the support units are connecting to the other LISN.

The LISN provides 50 ohm coupling impedance for the measuring instrument.

Both sides of AC line were checked for maximum conducted interference.

The frequency range from 150 kHz to 30 MHz was sweep.

Set the test-receiver system to quasi peak detect function and average detect function, and to measure the conducted emissions values.

Test results were obtained from the following equation:

Emission Level (dB μ V) = LISN Factor (dB) + Cable Loss (dB) + Reading (dB μ V)

Margin (dB) = Emission Level (dB μ V) - Limit (dB μ V)

6.4. Measuring Results

PASS. (Test date:04-29-2025)



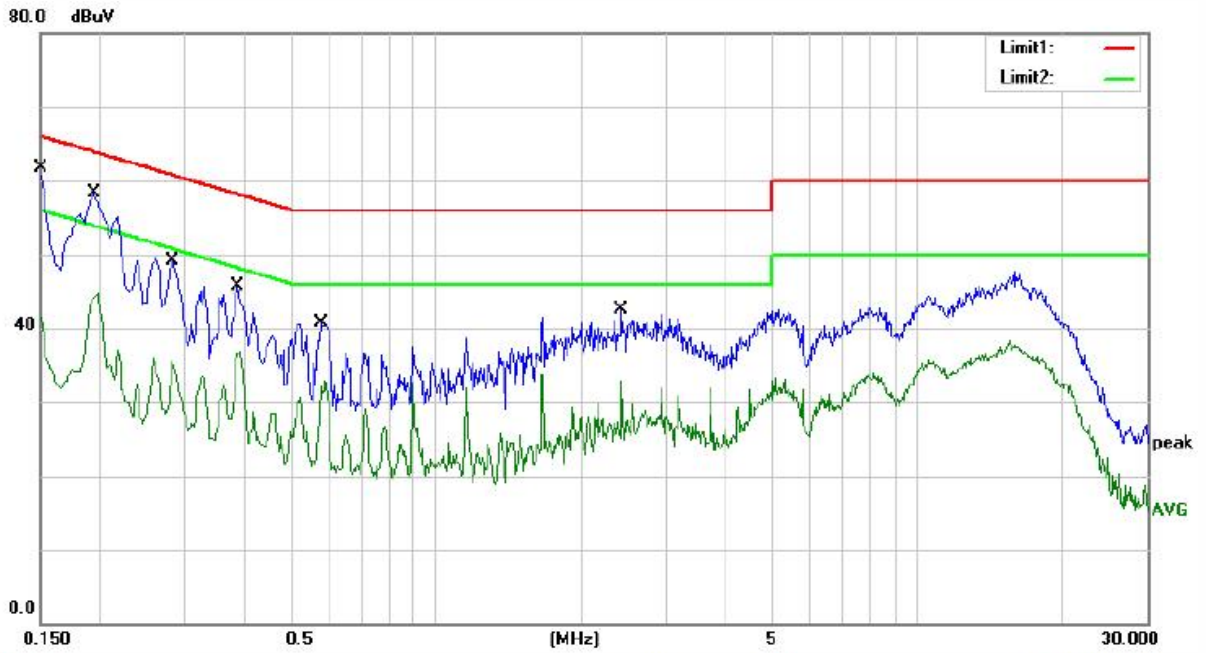

Site site #1

Phase: L1

Temperature: 21.3

No.	Mk.	Freq. MHz	Reading Level dBuV	Correct Factor dB	Measure- ment dBuV	Limit dBuV	Over dB	Detector	Comment
1		0.1500	40.24	17.06	57.30	66.00	-8.70	QP	
2		0.1500	25.84	17.06	42.90	56.00	-13.10	AVG	
3	*	0.1940	41.25	17.03	58.28	63.86	-5.58	QP	
4		0.1940	27.75	17.03	44.78	53.86	-9.08	AVG	
5		0.2820	32.05	17.10	49.15	60.76	-11.61	QP	
6		0.2820	18.34	17.10	35.44	50.76	-15.32	AVG	
7		0.3860	28.65	17.04	45.69	58.15	-12.46	QP	
8		0.3860	19.88	17.04	36.92	48.15	-11.23	AVG	
9		0.5780	23.69	17.07	40.76	56.00	-15.24	QP	
10		0.5780	15.86	17.07	32.93	46.00	-13.07	AVG	
11		2.4340	25.35	17.07	42.42	56.00	-13.58	QP	
12		2.4340	15.92	17.07	32.99	46.00	-13.01	AVG	

*:Maximum data x:Over limit !:over margin Comment: Factor build in receiver. Operator: Jian

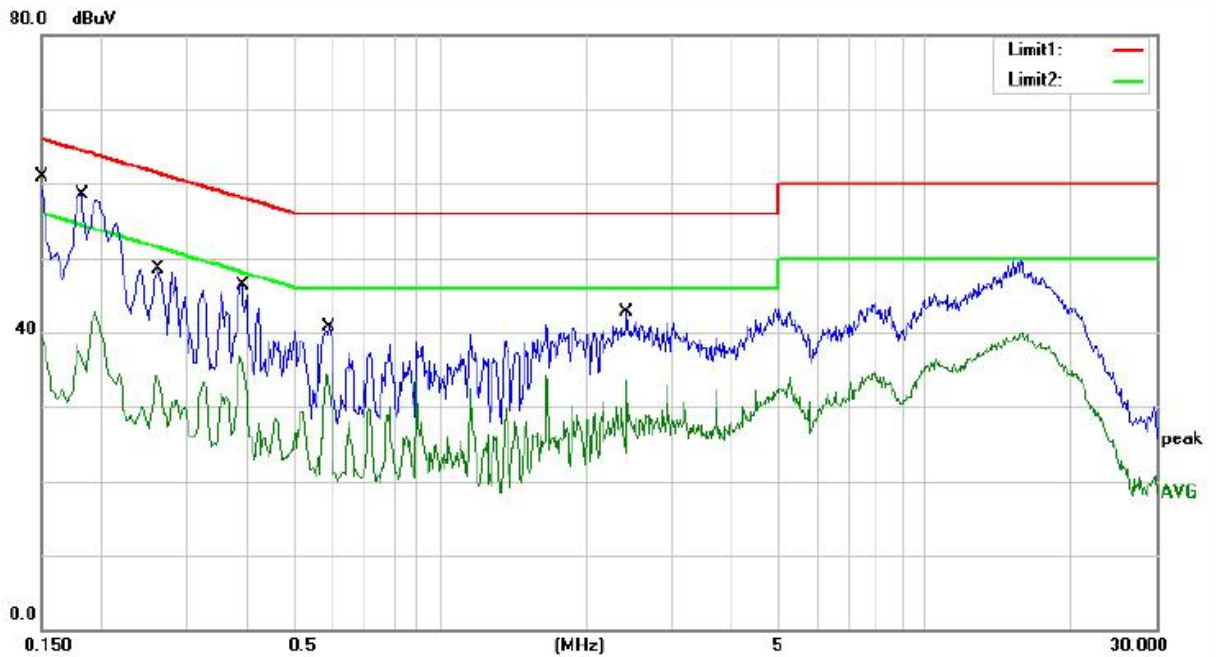

Site site #1 Phase: **N** Temperature: 21.3

No.	Mk.	Freq.	Reading Level	Correct Factor	Measurement	Limit	Over	Detector	Comment
		MHz	dBuV	dB	dBuV	dBuV	dB		
1	*	0.1500	43.93	17.06	60.99	66.00	-5.01	QP	
2		0.1500	22.82	17.06	39.88	56.00	-16.12	AVG	
3		0.1820	41.52	17.04	58.56	64.39	-5.83	QP	
4		0.1820	25.73	17.04	42.77	54.39	-11.62	AVG	
5		0.2620	31.44	17.08	48.52	61.37	-12.85	QP	
6		0.2620	17.05	17.08	34.13	51.37	-17.24	AVG	
7		0.3900	29.32	17.04	46.36	58.06	-11.70	QP	
8		0.3900	19.80	17.04	36.84	48.06	-11.22	AVG	
9		0.5900	23.70	17.07	40.77	56.00	-15.23	QP	
10		0.5900	17.14	17.07	34.21	46.00	-11.79	AVG	
11		2.4340	25.55	17.07	42.62	56.00	-13.38	QP	
12		2.4340	16.38	17.07	33.45	46.00	-12.55	AVG	

*:Maximum data x:Over limit !:over margin Comment: Factor build in receiver. Operator: Jian

Remark:

1. Measurement (dBμV) = AMN Factor (dB) + Cable Loss (dB) + Reading (dBμV)
2. Over (dB) = Measurement (dBμV) - Limit (dBμV)

7. RADIATED EMISSION TEST

7.1.Measurement Procedure

1. The EUT was placed on a turn table which is 0.8m above ground plane.
2. Maximum procedure was performed on the six highest emissions to ensure EUT compliance.
3. And also, each emission was to be maximized by changing the polarization of receiving antenna both horizontal and vertical.
4. Repeat above procedures until all frequency measured were complete.
5. Use the following receiver/spectrum analyzer settings:
 Span = wide enough to fully capture the emission being measured
 RBW=200Hz for 9KHz to 150KHz,
 RBW=9kHz for 150KHz to 30MHz,
 RBW=120KHz for 30MHz to 1GHz
 VBW $\geq 3 \times$ RBW
 Sweep = auto
 Detector function = QP
 Trace = max hold

7.2.Test SET-UP (Block Diagram of Configuration)

(A) Radiated Emission Test Set-Up, Frequency Below 30MHz

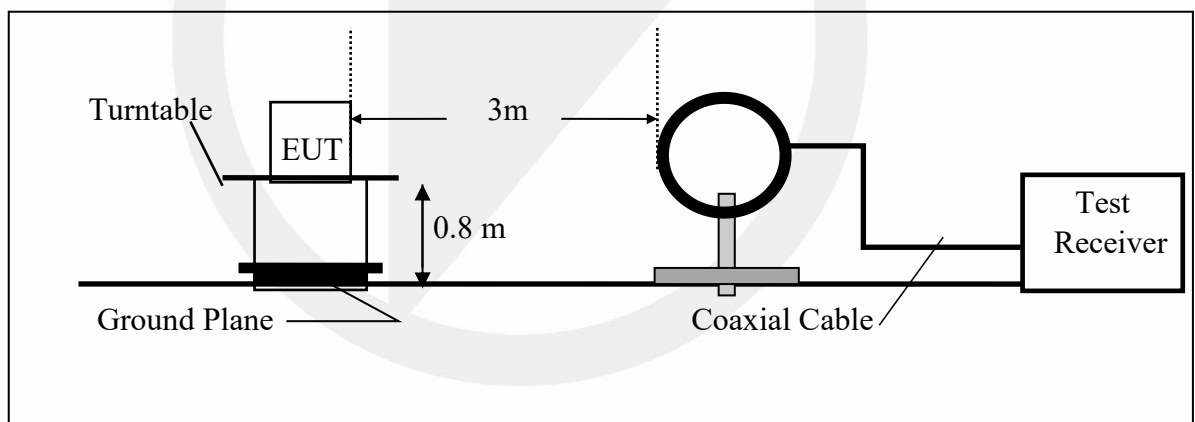

(B) Radiated Emission Test Set-Up, Frequency Below 1000MHz

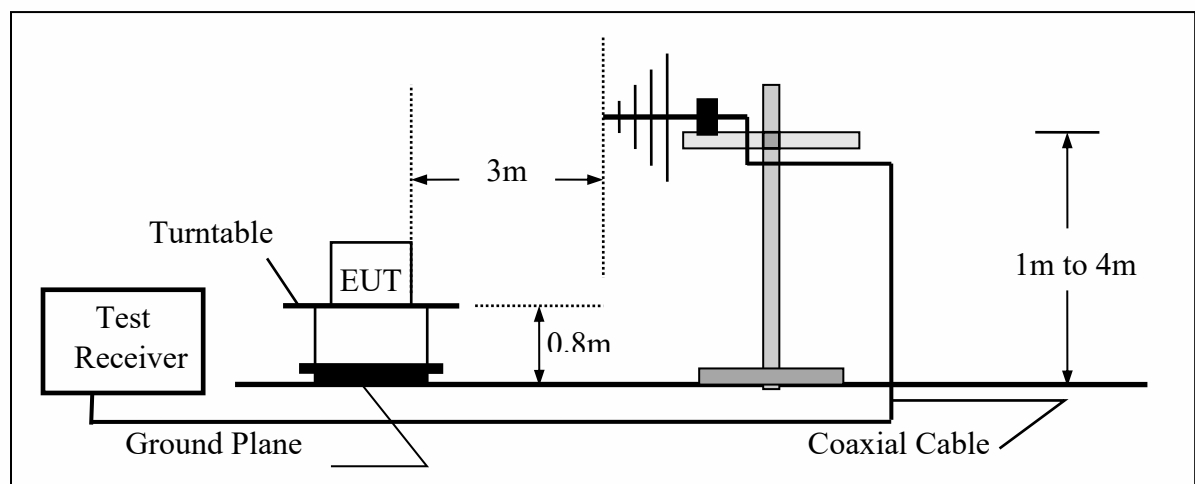

7.3. Radiated Emission Limit

The emissions from an intentional radiator shall not exceed the field strength levels specified in the following table 15.209(a):

FCC Part 15.209				
Frequency (MHz)	Field Strength Limitation		Field Strength Limitation Frequency tion at 3m Measurement Dist	
	(uV/m)	Dist	(uV/m)	(dBuV/m)
0.009 – 0.490	2400 / F(KHz)	300m	10000 * 2400/F(KHz)	20log 2400/F(KHz) + 80
0.490 – 1.705	24000 / F(KHz)	30m	100 * 24000/F(KHz)	20log 24000/F(KHz) + 40
1.705 – 30.00	30	30m	100* 30	20log 30 + 40
30.0 – 88.0	100	3m	100	20log 100
88.0 – 216.0	150	3m	150	20log 150
216.0 – 960.0	200	3m	200	20log 200
Above 960.0	500	3m	500	20log 500

15.205 Restricted bands of operation

MHz	MHz	MHz	GHz
0.090 - 0.110	16.42 - 16.423	399.9 - 410	4.5 - 5.15
¹ 0.495 - 0.505	16.69475 - 16.69525	608 - 614	5.35 - 5.46
2.1735 - 2.1905	16.80425 - 16.80475	960 - 1240	7.25 - 7.75
4.125 - 4.128	25.5 - 25.67	1300 - 1427	8.025 - 8.5
4.17725 - 4.17775	37.5 - 38.25	1435 - 1626.5	9.0 - 9.2
4.20725 - 4.20775	73 - 74.6	1645.5 - 1646.5	9.3 - 9.5
6.215 - 6.218	74.8 - 75.2	1660 - 1710	10.6 - 12.7
6.26775 - 6.26825	108 - 121.94	1718.8 - 1722.2	13.25 - 13.4
6.31175 - 6.31225	123 - 138	2200 - 2300	14.47 - 14.5
8.291 - 8.294	149.9 - 150.05	2310 - 2390	15.35 - 16.2
8.362 - 8.366	156.52475 - 156.52525	2483.5 - 2500	17.7 - 21.4
8.37625 - 8.38675	156.7 - 156.9	2690 - 2900	22.01 - 23.12
8.41425 - 8.41475	162.0125 - 167.17	3260 - 3267	23.6 - 24.0
12.29 - 12.293	167.72 - 173.2	3332 - 3339	31.2 - 31.8
12.51975 - 12.52025	240 - 285	3345.8 - 3358	36.43 - 36.5
12.57675 - 12.57725	322 - 335.4	3600 - 4400	(²)

- Remark:
1. Emission level in dBuV/m=20 log (uV/m)
 2. Measurement was performed at an antenna to the closed point of EUT distance of meters.
 3. Only spurious frequency is permitted to locate within the Restricted Bands specified in provision of § 15.205, and the emissions located in restricted bands also comply with 15.209 limit.

7.4.Measurement Result

Operation Mode:	Low frequency	Test Date :	2025.04.28
Frequency Range:	9KHz~30MHz	Temperature :	22.9℃
Test Result:	PASS	Humidity :	64.0 %
Measured Distance:	3m	Test By:	Ccyf

Freq. (MHz)	Ant.Pol. H/V	Emission Level (dBuV/m)	Limit 3m (dBuV/m)	Over (dB)	Note
0.0700	H	67.04	110.69	-43.65	PK
0.1276	H	81.49	105.48	-23.99	PK
0.2011	H	65.12	101.53	-36.41	PK
0.2650	H	65.32	99.14	-33.82	PK
0.4274	H	61.04	94.99	-33.95	PK
0.6210	H	56.66	71.75	-15.09	PK
0.0558	V	66.77	112.66	-45.89	PK
0.1276	V	79.68	105.48	-25.80	PK
0.2127	V	66.09	101.04	-34.95	PK
0.2943	V	63.04	98.23	-35.19	PK
0.4007	V	57.40	95.55	-38.15	PK
0.5866	V	54.25	72.24	-17.99	PK

- Note:** (1) All Readings are Peak Value.
 (2) Emission Level= Reading Level+Probe Factor +Cable Loss.
 (3) The average measurement was not performed when the peak measured data under the limit of average detection.
 (4) EUT lying on the table position is the worst case result in the report.

30MHz-1GHz:



Site Chamber #1 Polarization: **Horizontal** Temperature: 24.4 C

No.	Mk.	Freq.	Reading Level	Ant. Factor	Pre Amp Gain	Cable loss	Measurement	Limit	Over	HI	Degree	
		MHz	dBuV	dB/m	dB	dB	dBuV/m	dBuV/m	dB	Detector	cm	deg.
1		55.8046	37.67	12.92	29	0.92	22.51	40.00	-17.49	QP		
2		126.7723	53.47	9.52	28.77	1.39	35.61	43.50	-7.89	QP		
3		135.5061	50.57	8.45	28.75	1.44	31.71	43.50	-11.79	QP		
4		191.7450	52.48	9.82	28.59	1.7	35.41	43.50	-8.09	QP		
5	*	239.1473	53.53	11.6	28.45	1.78	38.46	46.00	-7.54	QP		
6		281.9945	46.18	12.64	28.33	1.99	32.48	46.00	-13.52	QP		

*:Maximum data x:Over limit !:over margin

Operator: Ccyf

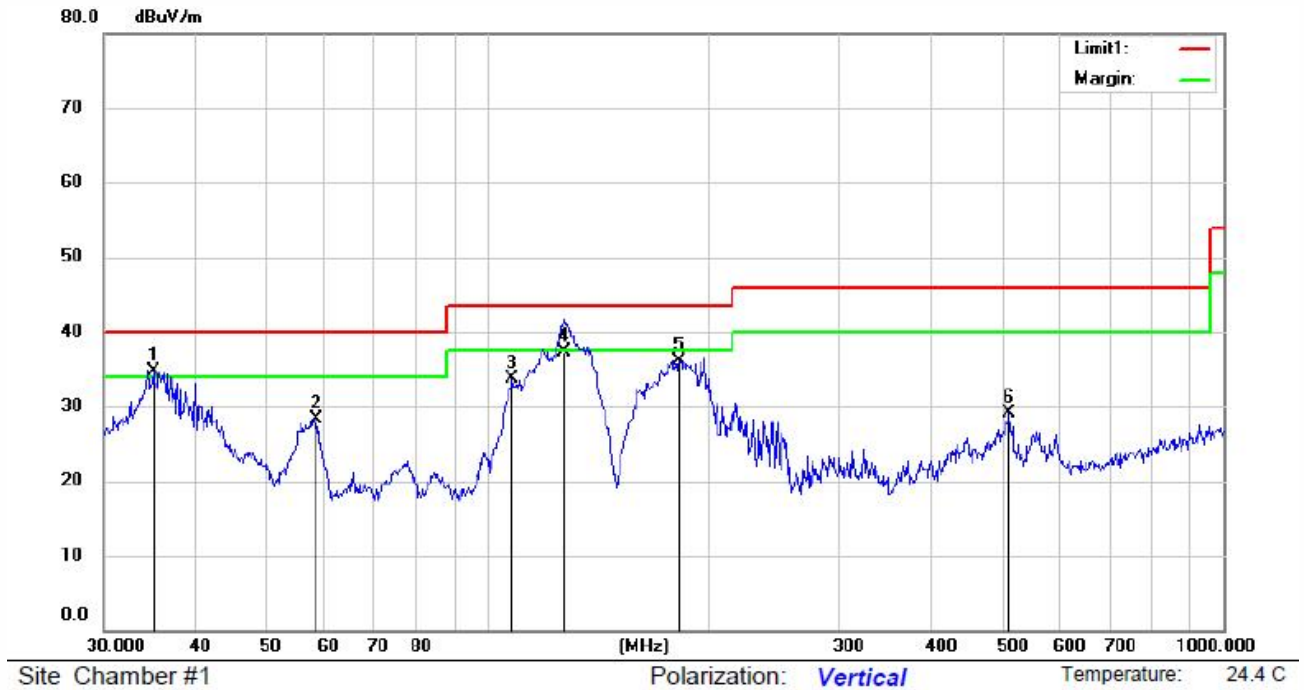

No.	Mk.	Freq. MHz	Reading Level dBuV	Ant. Factor dB/m	Pre Amp Gain dB	Cable loss dB	Measure- ment dBuV/m	Limit dBuV/m	Over dB	HI	Degree	Comment
1	*	35.0048	51.56	11.4	29.09	0.91	34.78	40.00	-5.22	QP		
2		58.4074	43.49	12.92	29.02	0.89	28.28	40.00	-11.72	QP		
3		107.8876	49.46	11.7	28.83	1.29	33.62	43.50	-9.88	QP		
4		126.7723	55.16	9.52	28.77	1.39	37.30	43.50	-6.20	QP		
5		181.9201	53.52	9.58	28.62	1.65	36.13	43.50	-7.37	QP		
6		511.8351	39.61	16.22	29.53	2.87	29.17	46.00	-16.83	QP		

*:Maximum data x:Over limit !:over margin

Operator: Ccyf

Remark:

1. Measurement (dBμV/m) = Antenna Factor(dB) -Amp Factor(dB) +Cable Loss(dB) + Reading(dBμV/m)
2. Over (dB) = Measurement (dBμV/m) - Limit (dBμV/m)

8. ANTENNA REQUIREMENT

The EUT's antenna, permanent attached antenna, used an Induction coil, The antenna's gain meets the requirement.



*** End of Report ***

声明 Statement

1. 本报告无授权批准人签字及“检验检测专用章”无效；
This report will be void without authorized signature or special seal for testing report.
2. 未经许可本报告不得部分复制；
This report shall not be copied partly without authorization.
3. 本报告的检测结果仅对送测样品有效，委托方对样品的代表性和资料的真实性负责；
The test results or observations are applicable only to tested sample. Client shall be responsible for representativeness of the sample and authenticity of the material.
4. 本检测报告中检测项目标注有特殊符号则该项目不在资质认定范围内，仅作为客户委托、科研、教学或内部质量控制等目的使用；
The observations or tests with special mark fall outside the scope of accreditation, and are only used for purpose of commission, research, training, internal quality control etc.
5. 本检测报告以实测值进行符合性判定，未考虑不确定度所带来的风险，本实验室不承担相关责任，特别约定、标准或规范中有明确规定的除外；
The test results or observations are provided in accordance with measured value, without taking risks caused by uncertainty into account. Without explicit stipulation in special agreements, standards or regulations, EMTEK shall not assume any responsibility.
6. 对本检测报告若有异议，请于收到报告之日起 20 日内提出；
Objections shall be raised within 20 days from the date receiving the report.