FCC PART 15 SUBPART C MEASUREMENT AND TEST REPORT

For

Dongguan ECHO Co., Ltd.

**2A15, Jiarun Building, No.106, Guanzhang Avenue, Dongcheng District,
Dongguan, Guangdong, China**

E.U.T.: 2.4G Wireless Optical Mouse

**Model Name: EFM1001BK, EFM1002PK, EFM1003WH,
EFM1004OR, EFM1005GN**

Trade name: N/A

FCC ID: COD-EFM1001-1

Report Number: NTC1203176F

Test Date(s): March 07 2012 to April 24 2012

Report Date(s): April 24 2012

Prepared by

Dongguan NTC Co., Ltd.

**Building D, Gaosheng Science and Technology Park,
Hongtu Road, Nancheng District,
Dongguan City, Guangdong Province, China**

Tel: +86-769-22022444

Fax: +86-769-22022799

Prepared By



Jeos Hong / Engineer

Approved & Authorized Signer



Sunm Lv / Q.A. Director

Note: This test report is for the customer shown above and their specific product only. It may not be duplicated or used in part without prior written consent from Dongguan NTC Co., Ltd. The test results referenced from this report are relevant only to the sample tested.

Table of Contents

1. GENERAL INFORMATION	3
1.1 PRODUCT DESCRIPTION FOR EQUIPMENT UNDER TEST	3
1.2 RELATED SUBMITTAL(S) / GRANT (S)	5
1.3 TEST METHODOLOGY	5
1.4 SPECIAL ACCESSORIES	5
1.5 SUPPORT DEVICE	5
1.6 TEST MODE	5
1.7 TEST FACILITY AND LOCATION	5
1.8 SUMMARY OF TEST RESULTS	6
2. CONDUCTED EMISSIONS TEST	7
TEST SET-UP (BLOCK DIAGRAM OF CONFIGURATION)	7
TEST CONDITIATION	7
MEASUREMENT RESULTS	7
3. RADIATED EMISSION TEST	10
TEST SET-UP (BLOCK DIAGRAM OF CONFIGURATION)	10
MEASUREMENT PROCEDURE	11
MEASUREMENT RESULTS	13
4. 20DB BANDWIDTH	19
MEASUREMENT PROCEDURE	19
MEASUREMENT RESULTS	19
5. BAND EDGE	21
MEASUREMENT PROCEDURE	21
LIMIT	21
MEASUREMENT RESULTS	21
6. ANTENNA REQUIRMENT	23
MEASUREMENT RESULTS	23
7. TEST EQUIPMENT LIST	24

1. GENERAL INFORMATION

1.1 Product Description for Equipment under Test

Manufacturer : Dongguan ECHO Co., Ltd.

Address : 2A15, Jiarun Building, No.106, Guanzhang Avenue,
Dongcheng District, Dongguan, Guangdong, China

Frequency: : 2405-2476MHz

Modulation : GFSK

Number of Channel : 64channels (there are 2 groups frequency and each of group has
32 channels, details see below channel list)

Antenna Type : Integral

Antenna Gain : -2dBi

Power Supply : DC 5.0V come from PC
:
:
:

Model name : EFM1001BK, EFM1002PK, EFM1003WH, EFM1004OR,
EFM1005GN

Note: All models are the same except model name and appearance color, we prepare EFM1005GN for EMC test.



Channel List

Frequency Group 1				Frequency Group 2			
CHANNEL	FREQ. (MHZ)	CHANNEL	FREQ. (MHz)	CHANNEL	FREQ. (MHz)	CHANNEL	FREQ. (MHz)
1	2407	17	2442	33	2405	49	2443
2	2408	18	2447	34	2406	50	2444
3	2412	19	2451	35	2419	51	2446
4	2414	20	2452	36	2410	52	2448
5	2417	21	2457	37	2411	53	2449
6	2420	22	2458	38	2413	54	2453
7	2421	23	2459	39	2415	55	2455
8	2422	24	2460	40	2416	56	2456
9	2427	25	2461	41	2418	57	2462
10	2428	26	2465	42	2419	58	2463
11	2431	27	2468	43	2423	59	2464
12	2435	28	2469	44	2425	60	2466
13	2436	29	2472	45	2429	61	2467
14	2437	30	2473	46	2430	62	2470
15	2438	31	2475	47	2432	63	2471
16	2439	32	2476	48	2434	64	2474

Note: According to section 15.31(m), regards to the operating frequency range over 10MHz, the Lowest, middle, and the Highest frequency of channel were selected to perform the test. The selected frequency see below:

- The Lowest frequency: 2405MHz
- The middle frequency: 2439MHz
- The Highest frequency: 2476MHz

1.2 Related Submittal(s) / Grant (s)

This is an application for certification of a transceiver for the USB Dongle unit, and the corresponding wireless mouse unit is subjected to FCC certification with FCC ID: COD-EFM1001.

1.3 Test Methodology

Both AC mains line-conducted and radiated emission measurements were performed according to the procedures in ANSI C63.4 (2003) . Radiated emission measurement was performed in semi-anechoic chamber and conducted emission measurement was performed in shield room. For radiated emission measurement, preliminary scans were performed in the semi-anechoic chamber only to determine the worst case modes. All radiated tests were performed at an antenna to EUT distance of 3 meters.

1.4 Special Accessories

Not available for this EUT intended for grant.

1.5 Support Device

IBM notebook PC, Model: 1834, P/N: 13N5615.

1.6 Test Mode

All test performance in normal operation and transmitting mode(TX), and keep the EUT with modulation in transmitting mode.

1.7 Test Facility and Location

Listed by FCC, August 02, 2011
The Certificate Registration Number is 665078.
Listed by Industry Canada, July 01, 2011
The Certificate Registration Number is 46405-9743.

Dongguan NTC Co., Ltd.
Building D, Gaosheng Science and Technology Park,
Hongtu Road, Nancheng District, Dongguan City,
Guangdong Province, China



1.8 Summary of Test Results

FCC Rules	Description Of Test	Result
§15.207	Conduction Emissions	Compliant
§15.249(a)/15.209	Radiated Emissions	Compliant
§15.249(d)/15.205	Band Edge	Compliant
§15.215(c)	20dB Occupied Bandwidth	Compliant
§15.203	Antenna Requirement	Compliant

2. Conducted Emissions Test

Test SET-UP (Block Diagram of Configuration)

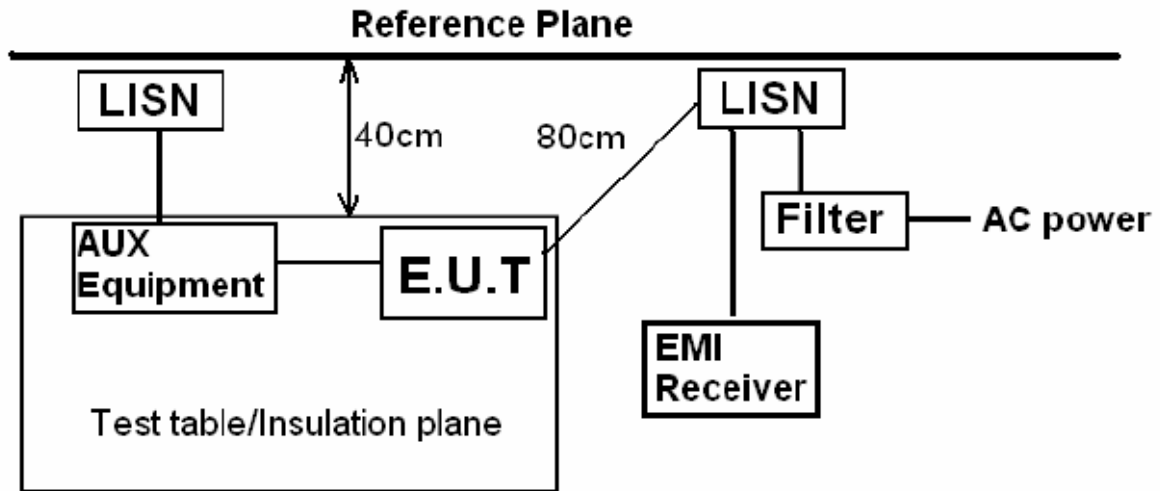

Test Condition

Test Requirement: FCC Part 15.207

Frequency Range: 150KHz ~ 30MHz

Detector: RBW 9KHz, VBW 30KHz

Operation Mode: Normal

Measurement Results

Please refer to following plots.

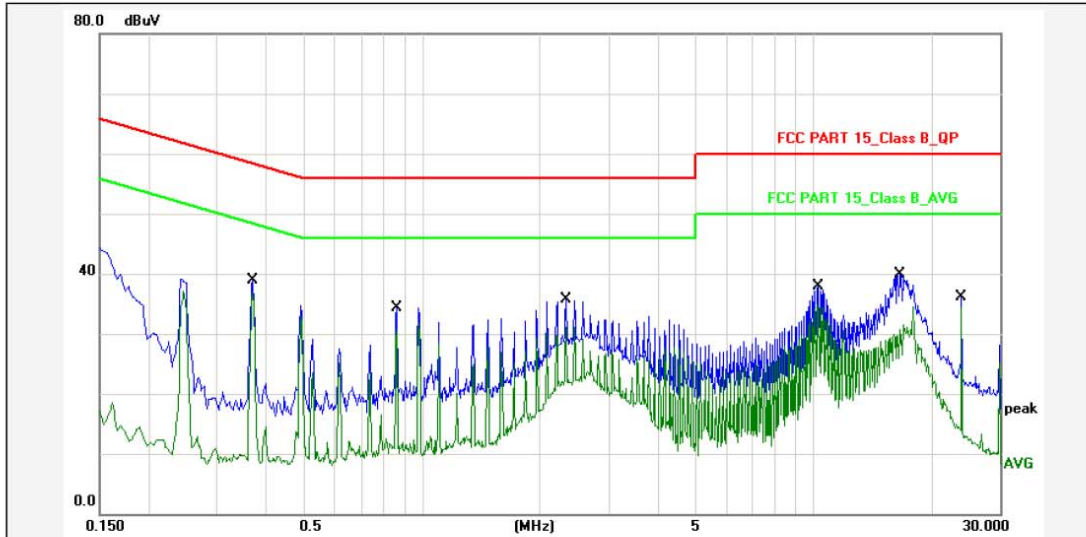

Report No.: wireless optical mouse
 Test Standard: FCC PART 15_Class B_QP
 Test item: Conducted Emission Phase: L1
 Applicant: ECHO Temp.()/Hum.(%): 24(C) / 58 %
 Product: 2.4G Wireless Optical Mouse (USB Dongle Part) Power Rating: AC 120V/60Hz
 Model No.: EFM1005GN Test Engineer: Infen
 Test Mode: Normal
 Remark:

No.	Frequency (MHz)	Factor (dBuV)	Reading (dBuV)	Level (dBuV)	Limit (dBuV)	Margin (dB)	Detector	P/F	Remark
1	0.3700	12.00	26.94	38.94	58.50	-19.56	QP	P	
2	0.3700	12.00	24.82	36.82	48.50	-11.68	AVG	P	
3	0.8620	12.00	22.34	34.34	56.00	-21.66	QP	P	
4	0.8620	12.00	18.54	30.54	46.00	-15.46	AVG	P	
5	2.3340	12.00	23.68	35.68	56.00	-20.32	QP	P	
6	2.3340	12.00	19.08	31.08	46.00	-14.92	AVG	P	
7	10.3220	12.00	25.81	37.81	60.00	-22.19	QP	P	
8	10.3220	12.00	22.87	34.87	50.00	-15.13	AVG	P	
9	16.7060	12.00	28.00	40.00	60.00	-20.00	QP	P	
10	16.7060	12.00	19.56	31.56	50.00	-18.44	AVG	P	
11	23.9540	12.00	24.18	36.18	60.00	-23.82	QP	P	
12	23.9540	12.00	22.36	34.36	50.00	-15.64	AVG	P	

Note: Level=Reading+Factor.

Margin=Limit-Level.



Dongguan NTC Co., Ltd.
 Tel: +86-769-22022444 Fax: +86-769-22022799
 Web: [Http://www.ntc-c.com](http://www.ntc-c.com)

Site: Conduction

Test Time: 2012-4-12 16:27:44

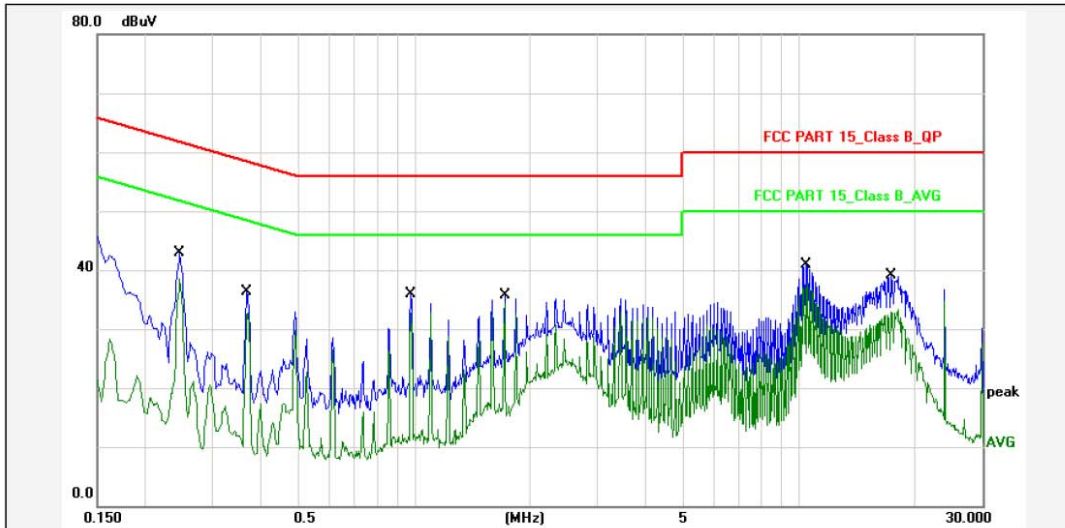

Report No.: wireless optical mouse
 Test Standard: FCC PART 15_Class B_QP
 Test item: Conducted Emission Phase: N
 Applicant: ECHO Temp.()/Hum.(%): 24(C) / 58 %
 Product: 2.4G Wireless Optical Mouse (USB Dongle Part) Power Rating: AC 120V/60Hz
 Model No.: EFM1005GN Test Engineer: Infen
 Test Mode: Normal
 Remark:

No.	Frequency (MHz)	Factor (dBuV)	Reading (dBuV)	Level (dBuV)	Limit (dBuV)	Margin (dB)	Detector	P/F	Remark
1	0.2460	12.00	30.92	42.92	61.89	-18.97	QP	P	
2	0.2460	12.00	26.45	38.45	51.89	-13.44	AVG	P	
3	0.3660	12.00	24.24	36.24	58.59	-22.35	QP	P	
4	0.3660	12.00	20.69	32.69	48.59	-15.90	AVG	P	
5	0.9820	12.00	23.84	35.84	56.00	-20.16	QP	P	
6	0.9820	12.00	20.63	32.63	46.00	-13.37	AVG	P	
7	1.7180	12.00	23.77	35.77	56.00	-20.23	QP	P	
8	1.7180	12.00	22.22	34.22	46.00	-11.78	AVG	P	
9	10.4340	12.00	28.83	40.83	60.00	-19.17	QP	P	
10	10.4340	12.00	25.74	37.74	50.00	-12.26	AVG	P	
11	17.4340	12.00	27.09	39.09	60.00	-20.91	QP	P	
12	17.4340	12.00	20.85	32.85	50.00	-17.15	AVG	P	

Note: Level=Reading+Factor.
 Margin=Limit-Level.

3. Radiated Emission Test

Test SET-UP (Block Diagram of Configuration)

Radiated Emission Test Set-Up, Frequency Below 1GHz

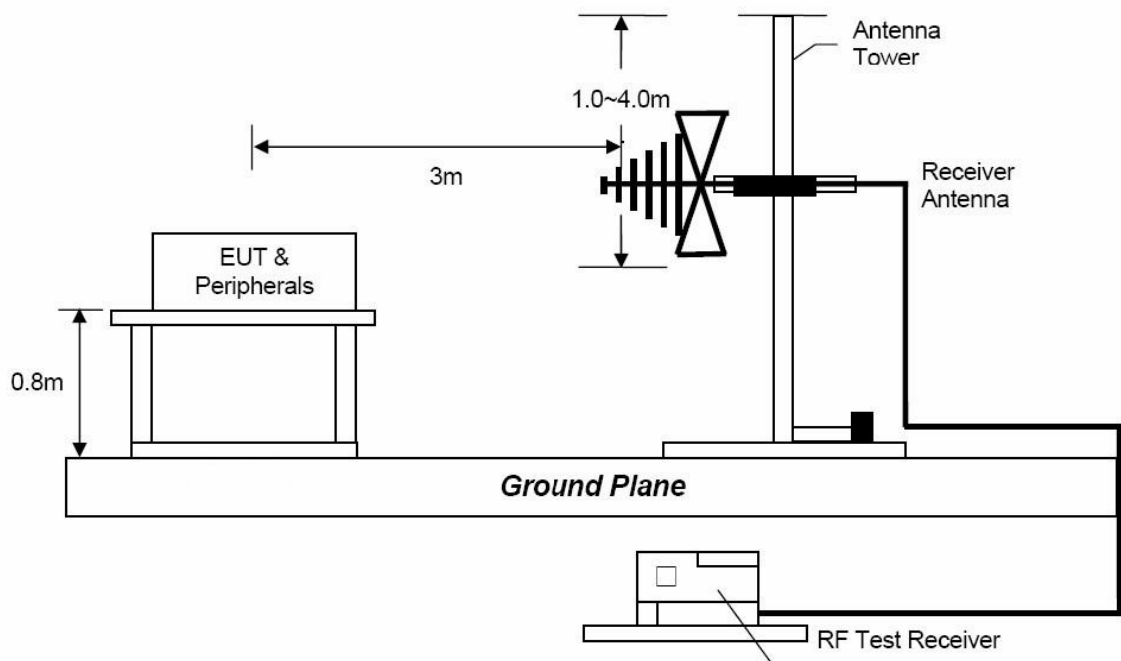
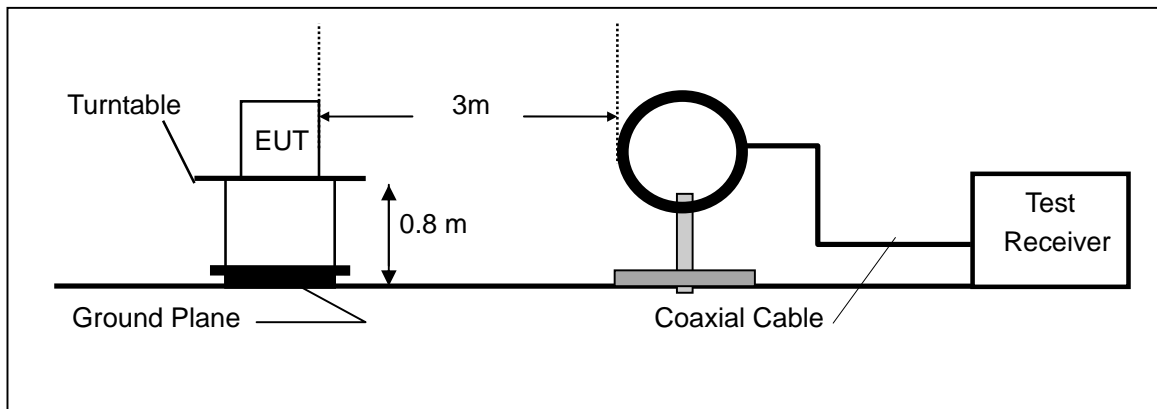

Radiated Emission Test Set-Up, Frequency above 1GHz

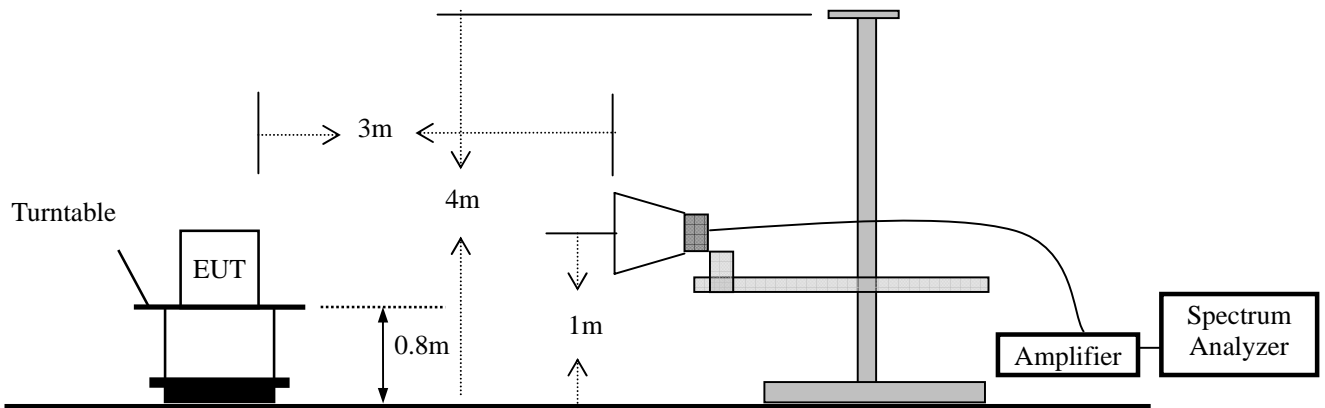

Measurement Procedure

- The EUT was placed on the top of a rotating table 0.8 meters above the ground at a 3 meter semi- anechoic chamber room. The table was rotated 360 degrees to determine the position of the highest radiation.
- The EUT was set 3 meters away from the interference-receiving antenna, which was mounted on the top of a variable-height antenna tower.
- The height of antenna is varied from one meter to four meters above the ground to determine the maximum value of the field strength. Both horizontal and vertical polarizations of the antenna are set to make the measurement.
- For each suspected emission, the EUT was arranged to its worst case and then the antenna was tuned to heights from 1 meter to 4 meters and the rotatable table was turned from 0 degrees to 360 degrees to find the maximum reading. The test-receiver system was set to peak detect function and specified bandwidth with maximum hold mode.

Limit

Frequency range MHz	Distance Meters	Field Strengths Limit (15.209)	
		μV/m	
0.009 ~ 0.490	300	2400/F(kHz)	
0.490 ~ 1.705	30	24000/F(kHz)	
1.705 ~ 30	30	30	
30 ~ 88	3	100	
88 ~ 216	3	150	
216 ~ 960	3	200	
Above 960	3	500	
Frequency range MHz	Distance Meters	Field Strengths Limit (15.249)	
		mV/m (Field strength of fundamental)	μV/m (Field strength of Harmonics)
902 ~ 928	3	50	500
2400 ~ 2483.5	3	50	500
5725 ~ 5875	3	50	500
24000 ~ 2425000	3	250	2500

- Remark :
- (1) Emission level (dB)μV = 20 log Emission level μV/m
 - (2) The smaller limit shall apply at the cross point between two frequency bands.
 - (3) As shown in 15.35(b), for frequencies above 1000MHz, the field strength limits are based on average detector, however, the peak field strength of any emission shall not exceed the maximum permitted average limits, specified above by more than 20dB under any condition of modulation.
 - (4) The frequency range scanned is from the lowest radio frequency signal generated in the device which is greater than 9 kHz to the tenth harmonic of the highest fundamental frequency or 40 GHz, whichever is lower.

Measurement Results

Operation Mode: Normal Mode
 Frequency Range: Below 1GHz Temperature : 22 °C
 Test Result: PASS Humidity : 54 %
 Measured Distance: 3m Test By: Think
 Test Date : April 14, 2012

Freq. (MHz)	Ant.Pol. H/V	Emission Level (dBuV)	Limit 3m (dBuV/m)	Margin (dB)	Note
50.37	V	31.56	40.00	-8.44	QP
139.61	V	33.75	43.50	-9.75	QP
264.74	V	34.08	46.00	-11.92	QP
373.38	V	28.69	46.00	-17.31	QP
747.80	V	29.91	46.00	-16.09	QP
56.72	H	30.94	40.00	-9.06	QP
153.91	H	33.62	43.50	-9.88	QP
288.42	H	29.13	46.00	-16.87	QP
872.93	H	31.65	46.00	-14.35	QP
911.65	H	32.78	46.00	-13.22	QP

Other emissions are lower than 10dB below the allowable limit.

- Note:**
- (1) Quasi-Peak detector is used except for others stated.
 - (2) Emission Level= Reading Level+Probe Factor +Cable Loss
 - (3) Measurement uncertainty : ±3.7dB



Operation Mode: TX Mode (Low) Test Date : April 14, 2012
 Frequency Range: Above 1GHz Temperature : 22 °C
 Test Result: PASS Humidity : 54 %
 Measured Distance: 3m Test By: Think

Freq. (MHz)	Ant.Pol. H/V	Emission Level(dBuV)		Limit 3m(dBuV/m)		Margin(dB)	
		PK	AV	PK	AV	PK	AV
2405	V	87.26	63.76	114.00	94.00	-26.74	-30.24
4810	V	52.63	29.13	74.00	54.00	-21.37	-24.87
9620	V	53.09	29.59	74.00	54.00	-20.91	-24.41
12025	V	55.78	32.28	74.00	54.00	-18.22	-21.72
2405	H	85.13	61.63	114.00	94.00	-28.87	-32.37
4810	H	51.90	28.40	74.00	54.00	-22.10	-15.60
9620	H	52.79	29.29	74.00	54.00	-21.21	-24.71
12025	H	56.01	32.51	74.00	54.00	-17.99	-21.49

Other harmonics emissions are lower than 10dB below the allowable limit.

- Note:**
- (1) Peak Detector Data unless otherwise stated.
 - (2) Emission Level= Reading Level+Probe Factor +Cable Loss
 - (3) Measurement uncertainty : ±3.7dB
 - (4) The average value of fundamental frequency is: Average = Peak value + 20log(Duty cycle) Where the duty factor is calculated from following formula:

The duration of one cycle = 280us

Effective period of the cycle = 4.2ms

Duty cycle = 0.280ms / 4.2ms = 0.0667 or 6.67%

20 log (Duty cycle) =20 log₁₀ 0.0667= -23.5dB

Please see page 16 and 17 the worst-case plots.



Operation Mode: TX Mode (Mid) Test Date : April 14, 2012
 Frequency Range: Above 1GHz Temperature : 22 °C
 Test Result: PASS Humidity : 54 %
 Measured Distance: 3m Test By: Think

Freq. (MHz)	Ant.Pol. H/V	Emission Level(dBuV)		Limit 3m(dBuV/m)		Margin(dB)	
		PK	AV	PK	AV	PK	AV
2439	V	85.69	62.19	114.00	94.00	-28.31	-31.81
4878	V	49.97	26.47	74.00	54.00	-24.03	-27.53
7317	V	51.23	27.73	74.00	54.00	-22.77	-26.27
9756	V	53.91	30.41	74.00	54.00	-20.09	-23.59
2439	H	84.82	61.32	114.00	94.00	-29.18	-32.68
4878	H	48.63	25.13	74.00	54.00	-25.37	-28.87
7317	H	52.15	28.65	74.00	54.00	-21.85	-25.35
9756	H	53.43	29.93	74.00	54.00	-20.57	-24.07

Other harmonics emissions are lower than 10dB below the allowable limit.

- Note:**
- (1) Peak Detector Data unless otherwise stated.
 - (2) Emission Level= Reading Level+Probe Factor +Cable Loss
 - (3) Measurement uncertainty : ± 3.7dB
 - (4) The average value of fundamental frequency is: Average = Peak value + 20log(Duty cycle) Where the duty factor is calculated from following formula:

The duration of one cycle = 280us

Effective period of the cycle = 4.2ms

Duty cycle = 0.280ms / 4.2ms = 0.0667 or 6.67%

20 log (Duty cycle) =20 log₁₀ 0.0667= -23.5dB

Please see page 16 and 17 the worst-case plots.



Operation Mode: TX Mode (High) Test Date : April 14, 2012
 Frequency Range: Above 1GHz Temperature : 22 °C
 Test Result: PASS Humidity : 54 %
 Measured Distance: 3m Test By: Think

Freq. (MHz)	Ant.Pol. H/V	Emission Level(dBuV)		Limit 3m(dBuV/m)		Margin(dB)	
		PK	AV	PK	AV	PK	AV
2476	V	89.31	65.81	114.00	94.00	-24.69	-28.19
4952	V	51.69	28.19	74.00	54.00	-22.31	-25.81
7428	V	53.18	29.68	74.00	54.00	-20.82	-24.32
9904	V	55.12	31.62	74.00	54.00	-18.88	-22.38
2476	H	88.15	64.65	114.00	94.00	-25.85	-29.35
4952	H	52.37	28.87	74.00	54.00	-21.63	-25.13
7428	H	53.60	30.10	74.00	54.00	-20.40	-23.90
9904	H	54.91	31.41	74.00	54.00	-19.09	-22.59

Other harmonics emissions are lower than 10dB below the allowable limit.

- Note:**
- (1) Peak Detector Data unless otherwise stated.
 - (2) Emission Level= Reading Level+Probe Factor +Cable Loss
 - (3) Measurement uncertainty : ±3.7dB
 - (4) The average value of fundamental frequency is: Average = Peak value + 20log(Duty cycle) Where the duty factor is calculated from following formula:

The duration of one cycle = 280us

Effective period of the cycle = 4.2ms

Duty cycle = 0.280ms / 4.2ms = 0.0667 or 6.67%

20 log (Duty cycle) =20 log₁₀ 0.0667= -23.5dB

Please see page 16 and 17 the worst-case plots.

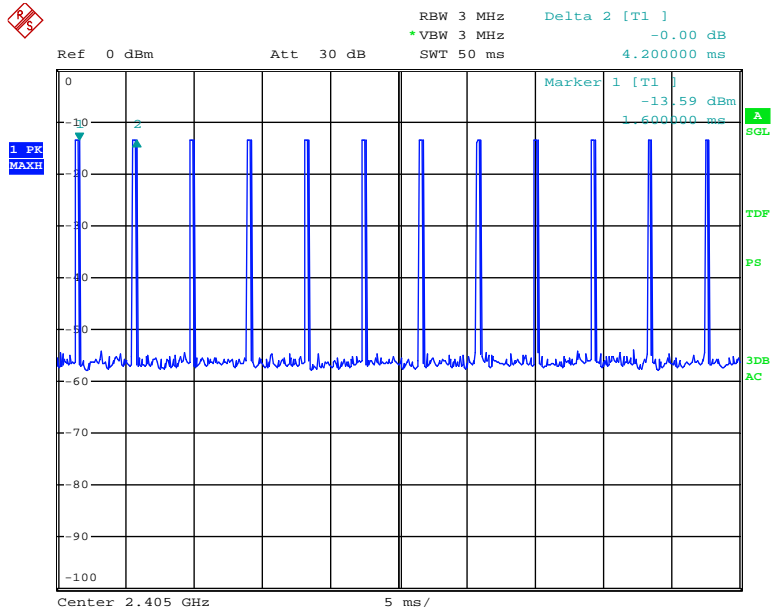

Date: 14.APR.2012 10:37:44

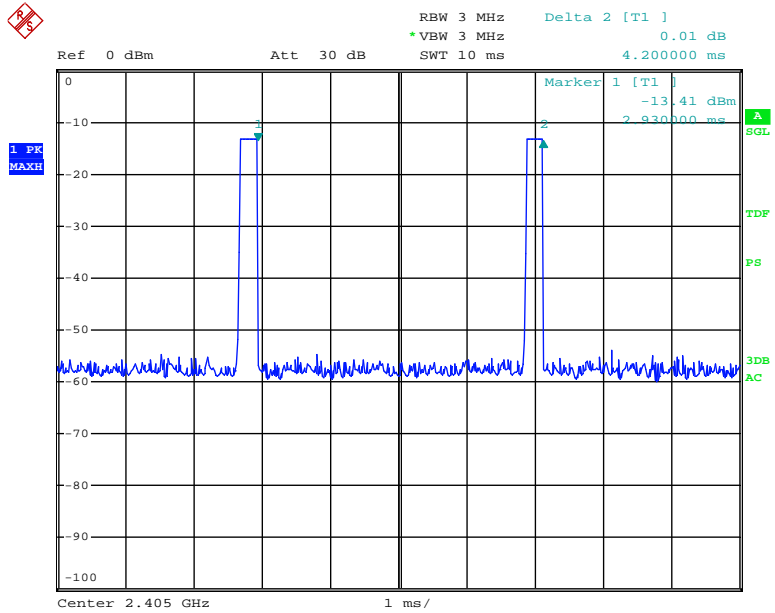

Date: 14.APR.2012 10:39:29

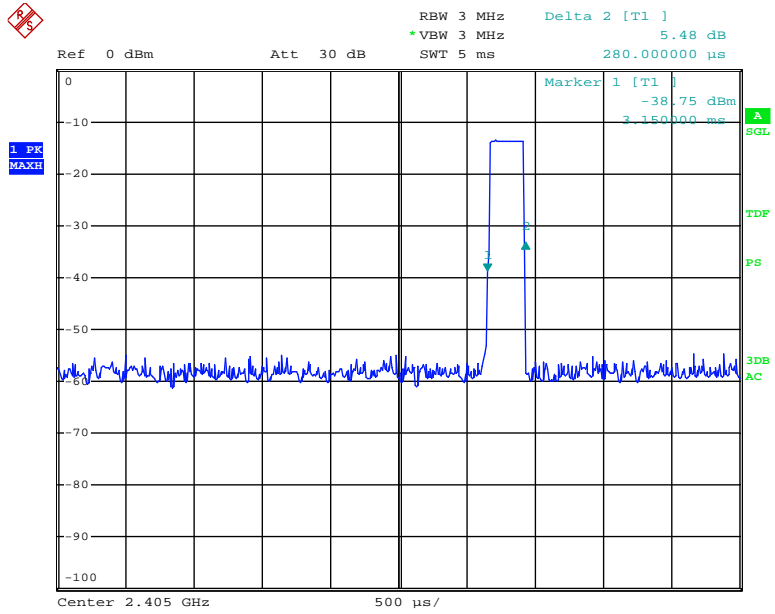

Date: 14.APR.2012 10:38:41

4. 20dB Bandwidth

Measurement Procedure

The 20dB bandwidth of the emission was contained within the frequency band designated which the EUT operated. The effects, if any, from frequency sweeping, frequency hopping, other modulation techniques and frequency stability over expected variations in temperature and supply voltage were considered, FCC Rule 15.215(c):

The antenna port of the EUT was connected to the input of a spectrum analyzer. Analyzer RBW was chosen so that the display was a result of the hopping channel modulation. For each RF output channel investigated, the spectrum analyzer center frequency was set to the channel carrier. Use the spectrum 20dB down delta function to measure the bandwidth.

Measurement Results

Please see below the worst-case plots.

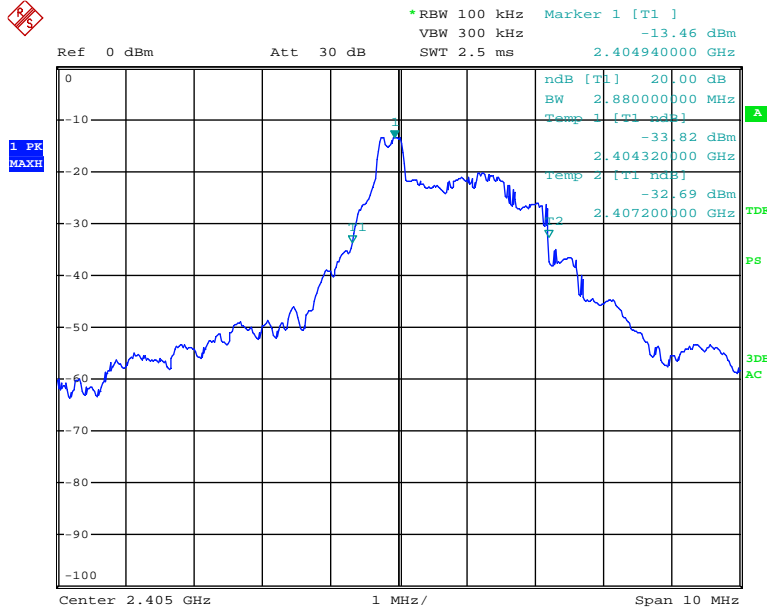

Date: 14.APR.2012 09:36:49

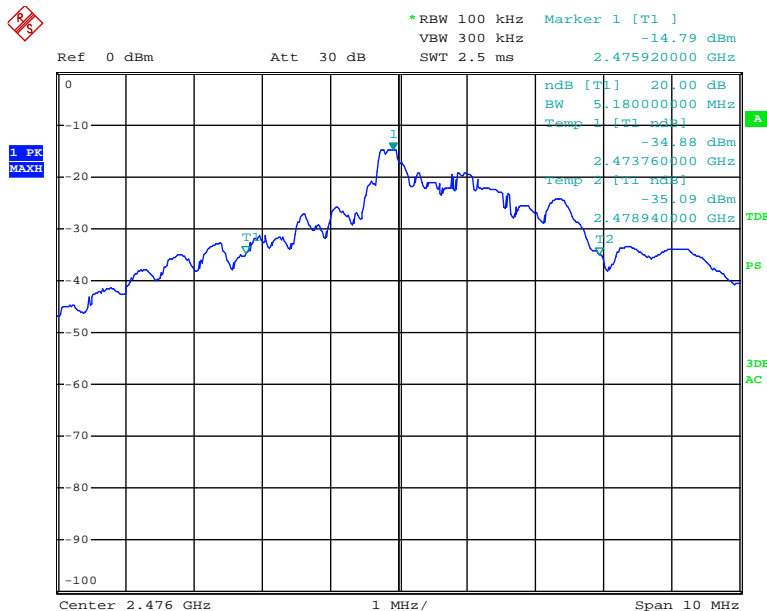

Date: 14.APR.2012 09:42:29

5. Band Edge

Measurement Procedure

Same as Radiated Emission Test.

Limit

Emissions radiated outside of the specified frequency bands, except for harmonics, shall be attenuated by at least 50 dB below the level of the fundamental or to the general radiated emission limits in §15.209, whichever is the lesser attenuation.

Measurement Results

The resultant field strength meets the general radiated emission limit in section 15.209, which does not exceed 74dB μ v/m (Peak Limit) and 54dB μ v/m (Average Limit). Average=Peak value + 20log(Duty cycle), and the bandedge plot shown in page 22.

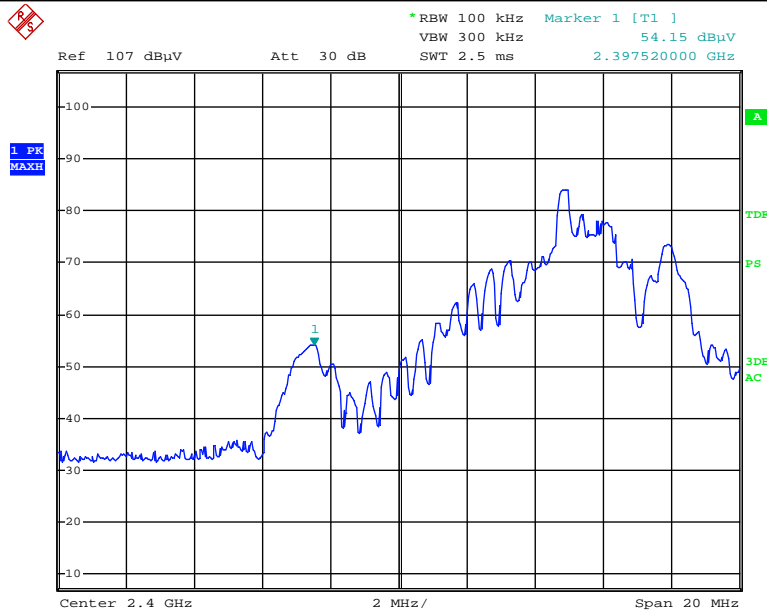

Date: 24.APR.2012 14:10:11

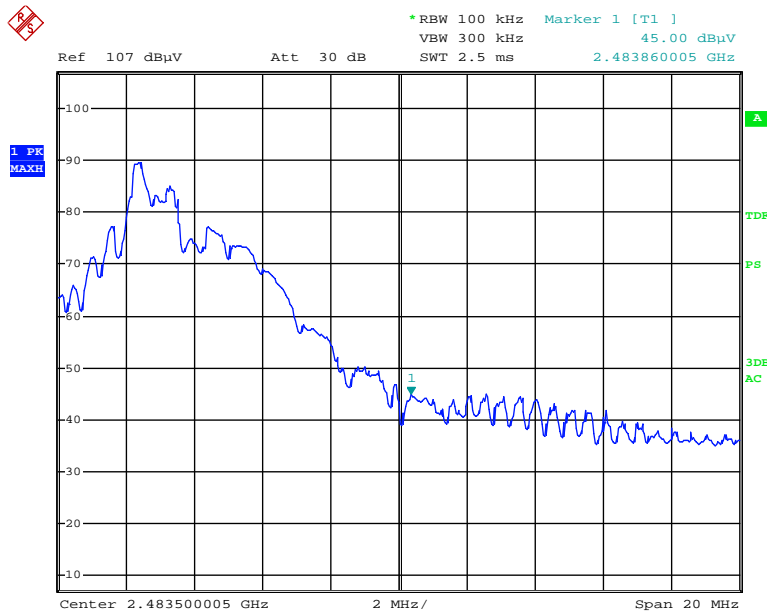

Date: 24.APR.2012 14:02:10

6. Antenna Requirement

According to of FCC part 15C section 15.203:

An intentional radiator shall be designed to ensure that no antenna other than that furnished by the responsible party shall be used with the device. The use of a permanently attached antenna or of an antenna that uses a unique coupling to the intentional radiator, the manufacturer may design the unit so that a broken antenna can be replaced by the user, but the use of a standard antenna jack or electrical connector is prohibited.

Measurement Results

The antenna is integrated on the main PCB and no consideration of replacement. The best case gain of the antenna is -2dBi.

7. Test Equipment List

Description	Manfucaturer	Model Number	Serial Number	Calibration Date	Calibration Due Date
Test Receiver	Rohde & Schwarz	ESCI7	100837	Nov. 05, 2011	Nov. 05, 2012
Antenna	Schwarzbeck	VULB9162	9162-010	Nov. 28, 2011	Nov. 28, 2012
Positioning Controller	UC	UC 3000	N/A	N/A	N/A
Color Monitor	SUNSP0	SP-140A	N/A	N/A	N/A
Single Phase Power Line Filter	SAEMC	PF201A-32	110210	N/A	N/A
3 Phase Power Line Filter	SAEMC	PF401A-200	110318	N/A	N/A
DC Power Filter	SAEMC	PF301A-200	110245	N/A	N/A
Cable	UBER+SUHNER	CBL2-NN-1M	22320001	Nov. 05, 2011	Nov. 05, 2012
Cable	Schwarzbeck	CIL02	N/A	Nov. 05, 2011	Nov. 05, 2012
Power Amplifier	HP	HP 8447D	1145A00203	Nov. 05, 2011	Nov. 05, 2012
Horn Antenna	EMCO	3117	00062558	Oct. 19, 2011	Oct. 19, 2012
Horn Antenna (AUX)	EMCO	3117	00085519	Nov. 07, 2011	Nov. 07, 2012
Spectrum Analyzer	Rohde&Schwarz	ESU	100005	May 25, 2011	May 25, 2012
Cable	Schwarzbeck	CIL02	N/A	Nov. 05, 2011	Nov. 05, 2012
Pre-Amplifier	Agilent	8449B	3008A02964	Dec. 19, 2011	Dec. 19, 2012
Loop antenna	Daze	ZA30900A	0708	Oct.16, 2011	Oct.16, 2012