



CERTIFICATION TEST REPORT

Report Number. : 13573888-E1V2

Applicant : APPLE, INC.
ONE APPLE PARK WAY
CUPERTINO, CA 95014, U.S.A.

Model : A2515

FCC ID : BCGA2515

IC : 579C-A2515

EUT Description : MAGNETIC CHARGING CABLE

Test Standard(s) : FCC 47 CFR PART 15 SUBPART C
ISED RSS-216 ISSUE 2
ISED RSS-GEN ISSUE 5 + A1 + A2

Date Of Issue:

August 18, 2021

Prepared by:

UL Verification Services Inc.
47173 Benicia Street
Fremont, CA 94538 U.S.A.
TEL: (510) 319-4000
FAX: (510) 661-0888

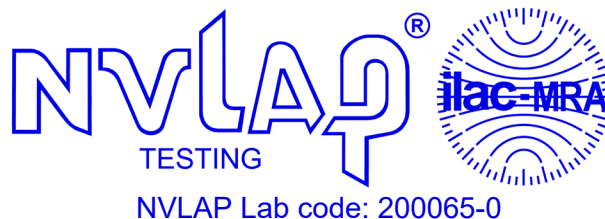

Revision History

<u>Rev.</u>	<u>Issue Date</u>	<u>Revisions</u>	<u>Revised By</u>
V1	8/13/2021	Initial Issue	Chin Pang
V2	8/18/2021	Address TCB's Questions on section 5.4 and 7	Chin Pang

TABLE OF CONTENTS

1. ATTESTATION OF TEST RESULTS	4
2. TEST METHODOLOGY	6
3. FACILITIES AND ACCREDITATION	6
4. CALIBRATION AND UNCERTAINTY	6
4.1. MEASURING INSTRUMENT CALIBRATION	6
4.2. SAMPLE CALCULATION	6
4.3. MEASUREMENT UNCERTAINTY	7
5. EQUIPMENT UNDER TEST	8
5.1. DESCRIPTION OF EUT	8
5.2. MAXIMUM OUTPUT POWER.....	8
5.3. SOFTWARE AND FIRMWARE.....	8
5.4. WORST-CASE CONFIGURATION AND MODE.....	9
5.5. DESCRIPTION OF TEST SETUP.....	10
6. TEST AND MEASUREMENT EQUIPMENT	12
7. OCCUPIED BANDWIDTH	13
7.1.1. CONFIG 1.....	14
7.1.2. CONFIG 2.....	14
7.1.3. CONFIG 3.....	15
7.1.4. CONFIG 4.....	15
7.1.5. CONFIG 5.....	16
8. RADIATED EMISSION TEST RESULTS.....	17
8.1. LIMITS AND PROCEDURE.....	17
8.1.1. FCC TX FUNDAMENTAL AND SPURIOUS EMISSIONS FROM 9 kHz TO 30 MHz 18	
8.1.2. IC / ICES-001 TX FUNDAMENTAL AND SPURIOUS EMISSIONS FROM 9 kHz TO 30 MHz	21
8.1.3. FCC TX SPURIOUS EMISSION 30 TO 1000 MHz	24
8.1.4. IC / ICES-001 TX SPURIOUS EMISSION 30 TO 1000 MHz.....	30
9. AC POWER LINE CONDUCTED EMISSIONS	36
9.1.1. STANDBY MODE POWERED BY AC/DC ADAPTER.....	37
9.1.2. OPERATING MODE (1.778MHz) WITH WATCH POWERED BY AC/DC ADAPTER.....	39
9.1.3. OPERATING MODE (326.5kHz) WITH WATCH POWERED BY AC/DC ADAPTER.....	41
10. SETUP PHOTO.....	43

1. ATTESTATION OF TEST RESULTS

COMPANY NAME: APPLE, INC.
ONE APPLE PARK WAY
CUPERTINO, CA 95014, U.S.A.

EUT DESCRIPTION: MAGNETIC CHARGING CABLE

MODEL: A2515

BRAND: APPLE

SERIAL NUMBER: DLC124602QL0KWT1Z

SAMPLE RECEIPT DATE: JUNE 19, 2021

DATE TESTED: JUNE 19, 2021 TO JULY 26, 2021

APPLICABLE STANDARDS	
STANDARD	TEST RESULTS
FCC PART 15 SUBPART C	Complies
ISED RSS-216 Issue 2, Annex B	Complies
ISED RSS-GEN Issue 5 + A1 + A2	Complies

UL Verification Services Inc. tested the above equipment in accordance with the requirements set forth in the above standards. The test results show that the equipment tested is capable of demonstrating compliance with the requirements as documented in this report.

The results documented in this report apply only to the tested sample, under the conditions and modes of operation as described herein. It is the manufacturer's responsibility to assure that additional production units of this model are manufactured with identical electrical and mechanical components. All samples tested were in good operating condition throughout the entire test program. Measurement Uncertainties are published for informational purposes only and were not taken into account unless noted otherwise.

This document may not be altered or revised in any way unless done so by UL Verification Services Inc. and all revisions are duly noted in the revisions section. Any alteration of this document not carried out by UL Verification Services Inc. will constitute fraud and shall nullify the document. This report must not be used by the client to claim product certification, approval, or endorsement by A2LA, NIST, any agency of the Federal Government, or any agency of the U.S. government.

Approved & Released For
UL Verification Services Inc. By:

Prepared By:



Chin Pang
Senior Engineer
Consumer Technology Division
UL Verification Services Inc.

Kyle Lo
Test Engineer
Consumer Technology Division
UL Verification Services Inc.

2. TEST METHODOLOGY

The tests documented in this report were performed in accordance with:

- FCC CFR 47 Part 2
- FCC CFR 47 Part 15
- ANSI C63.10-2013
- KDB 414788 D01 Radiated Test Site v01r01
- RSS-GEN Issue 5 + A1 + A2
- RSS-216 Issue 2

3. FACILITIES AND ACCREDITATION

UL Verification Services Inc. is accredited by A2LA, certification #0751.05, for all testing performed within the scope of this report. Testing was performed at the locations noted below.

	Address	ISED CABID	ISED Company Number	FCC Registration
<input type="checkbox"/>	Building 1: 47173 Benicia Street, Fremont, CA 94538	US0104	2324A	208313
<input checked="" type="checkbox"/>	Building 2: 47266 Benicia Street, Fremont, CA 94538	US0104	22541	208313
<input type="checkbox"/>	Building 4: 47658 Kato Rd, Fremont, CA 94538	US0104	2324B	208313

4. CALIBRATION AND UNCERTAINTY

4.1. MEASURING INSTRUMENT CALIBRATION

The measuring equipment utilized to perform the tests documented in this report has been calibrated in accordance with the manufacturer's recommendations, and is traceable to recognized national standards.

4.2. SAMPLE CALCULATION

RADIATED EMISSIONS

Where relevant, the following sample calculation is provided:

$$\text{Field Strength (dBuV/m)} = \text{Measured Voltage (dBuV)} + \text{Antenna Factor (dB/m)} + \text{Cable Loss (dB)} - \text{Preamp Gain (dB)}$$
$$36.5 \text{ dBuV} + 18.7 \text{ dB/m} + 0.6 \text{ dB} - 26.9 \text{ dB} = 28.9 \text{ dBuV/m}$$

MAINS CONDUCTED EMISSIONS

Where relevant, the following sample calculation is provided:

$$\text{Final Voltage (dBuV)} = \text{Measured Voltage (dBuV)} + \text{Cable Loss (dB)} + \text{Limiter Factor (dB)} + \text{LISN Insertion Loss.}$$
$$36.5 \text{ dBuV} + 0 \text{ dB} + 10.1 \text{ dB} + 0 \text{ dB} = 46.6 \text{ dBuV}$$

4.3. MEASUREMENT UNCERTAINTY

Where relevant, the following measurement uncertainty levels have been estimated for tests performed on the apparatus:

PARAMETER	UNCERTAINTY
Worst Case Conducted Disturbance, 9KHz to 0.15 MHz	3.78 dB
Worst Case Conducted Disturbance, 0.15 to 30 MHz	3.40 dB
Worst Case Radiated Disturbance, 9KHz to 30 MHz	2.87 dB
Worst Case Radiated Disturbance, 30 to 1000 MHz	6.01 dB

Uncertainty figures are valid to a confidence level of 95%.

5. EQUIPMENT UNDER TEST

5.1. DESCRIPTION OF EUT

The EUT is a magnetic charging cable which has a single inductive charging coil to charge Apple Watch. The charging frequencies are 1.778MHz and 326.5 kHz, and the maximum power consumption is 5W in charging status.

5.2. MAXIMUM OUTPUT POWER

The transmitter has maximum peak radiated electric and magnetic field strength as follows:

Fundamental Frequency (KHz)	Mode	E field (300m distance) FCC (dBuV/m)	H field (3m distance) IC (dBuA/m)
326.5	Standby (Config 1)	-23.16	-1.24
326.5	Operating (Config 2)	-24.85	.13

Fundamental Frequency (KHz)	Mode	E field (30m distance) FCC (dBuV/m)	H field (3m distance) IC (dBuA/m)
1778	Operating (Config 3)	-4.03	-5.02

5.3. SOFTWARE AND FIRMWARE

The firmware version installed in the EUT during testing was 1.5.7

5.4. WORST-CASE CONFIGURATION AND MODE

The EUT is a dual frequency magnetic charger enclosed in a Aluminum case. For the entire radiated emissions test, the EUT was investigated on the following configuration during the test at its natural orientation.

Config	Mode	Descriptions
1	Standby	EUT Alone powered by AC/DC adapter
2	Operating	EUT and Watch operating at 326.5kHz powered by AC/DC adapter
3	Operating	EUT and Watch operating at 1.778MHz powered by AC/DC adapter

AC power line conducted emissions were also investigated on the following configurations.

Config	Mode	Descriptions
1	Standby	EUT Alone powered by AC/DC adapter
2	Operating	EUT and Watch powered by AC/DC adapter
3	Operating	EUT and Watch operating at 1.778MHz powered by AC/DC adapter

For below 30MHz & 1GHz tests EUT was connected to AC power adapter as the worst case, the worst-case configuration reported was tested with EUT only. For AC line conducted emission, test was investigated with AC power adapter.

The EUT was tested as standby and operation modes. During operational mode, EUT was tested with two different sizes of watches, small and big of having similar mechanical structure.

For all radiated emissions tests, both small and big watches were investigated and no significant different in reading was found between both watches; the big watch was chosen to test as the worst case condition since it has max load overall, hence all final data for operational mode represents EUT with the big watch. During the charging process, the watch actively indicates the status of the charging process. Device being charged was at a state of 20 – 50% charged.

For below 30MHz testing, investigation was done on three antenna orientations: RX antenna Face-on, Face-off and horizontal (parallel to ground). The worst-case configurations were determined on RX antenna Face-on and Face-off; therefore, all final tests were performed using these two orientations.

Although these tests were performed other than open area test site, adequate comparison measurements were confirmed against 300 m open area test site. Therefore, sufficient tests were made to demonstrate that the alternative site produces result that correlate with the ones of tests made in an open field based on KDB 414788 D01.

5.5. DESCRIPTION OF TEST SETUP

SUPPORT EQUIPMENT & PERIPHERALS

SUPPORT EQUIPMENT & PERIPHERALS LIST				
Description	Manufacturer	Model	Serial Number	FCC ID
AC/DC adapter	Apple	A2305	C4H0313063ZPF4FAZ	N/A
Watch	Apple	A2477	FP4T9VJLQP	BCGA2477
Watch	Apple	A2376	GY6D202Z03P1	BCGA2376

I/O CABLES

I/O CABLE LIST						
Cable No.	Port	# of Identical Ports	Connector Type	Cable Type	Cable Length (m)	Remarks
1	DC	1	USB-C	Un-shielded	1	20W Power Supply

TEST SETUP

Please see the following configurations for the test setups. Configurations 1, 2 and 3 indicate that the EUT is directly connected to an AC/DC adapter via USB cable.

CONFIGURATION 1: STANDBY MODE

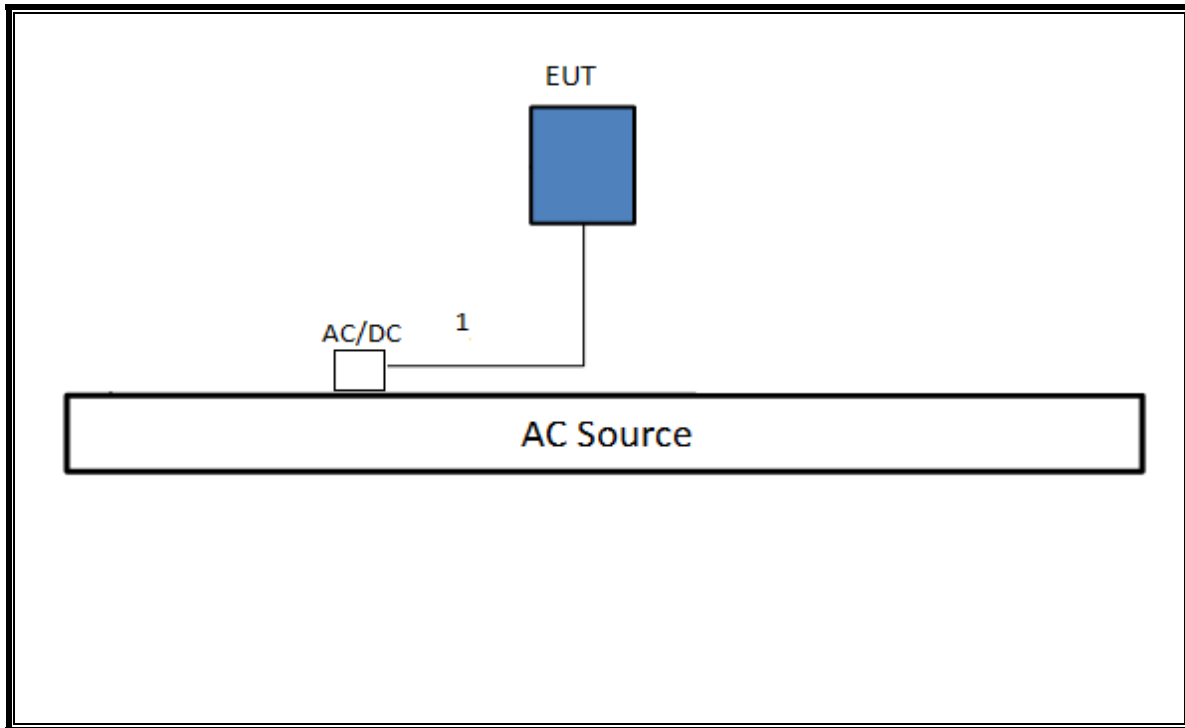

CONFIGURATION 2/3: OPERATING MODE WITH WATCH

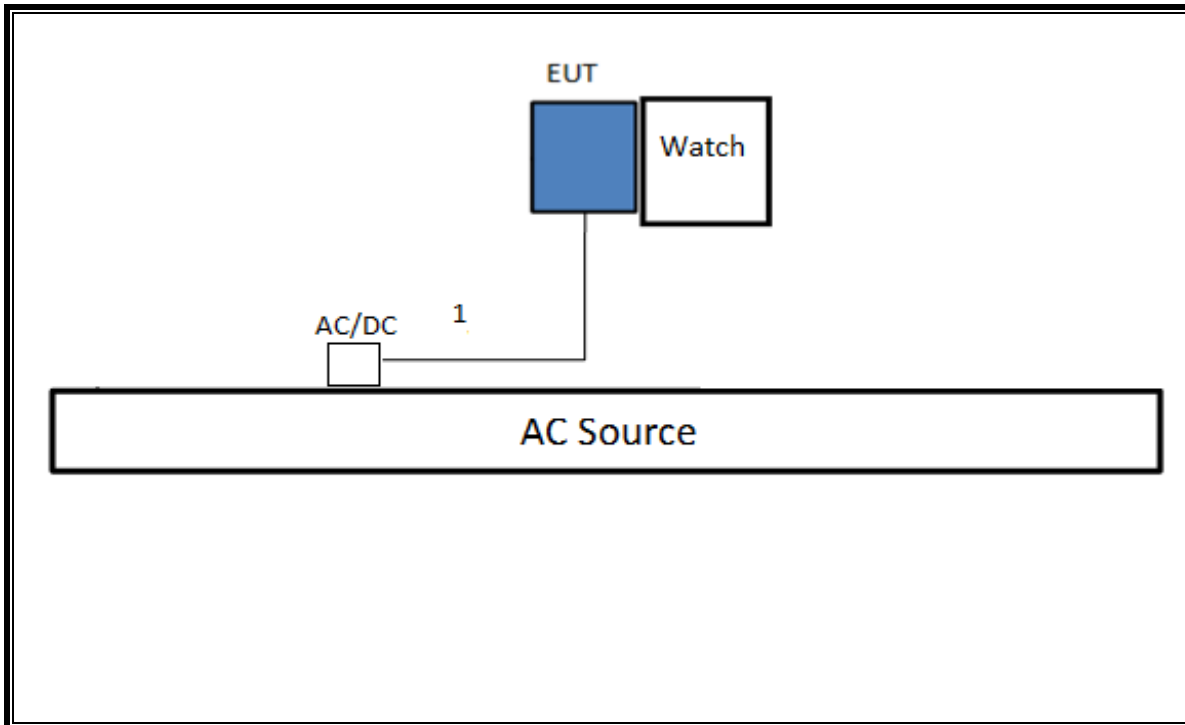

6. TEST AND MEASUREMENT EQUIPMENT

The following test and measurement equipment was utilized for the tests documented in this report:

TEST EQUIPMENT LIST				
Description	Manufacturer	Model	ID Num	Cal Due
Antenna, Active Loop 9KHz to 30MHz	ETS-Lindgren	6502	T1616	12/02/2021
Antenna, Broadband Hybrid, 30MHz to 2000MHz w/4dB	Sunol Sciences Crop.	JB3	T243	05/18/2022
Amplifier, 10kHz to 1GHz, 32dB	Sonoma Instrument	310N	T835	01/27/2022
Sniffer Probes	Electro Metrics	EM-6992	N/A	N/A
Spectrum Analyzer, PXA, 3Hz to 44GHz	Agilent (Keysight) Technologies	N9030A-544	T1113	12/17/2021

AC Line Conducted				
EMI Test Receiver 9KHz-7GHz	Rohde & Schwarz	ESCI7	T1436	02/19/2022
Power Cable, Line Conducted Emissions	UL	PR1	T861	11/27/2021
LISN for Conducted Emissions CISPR-16	Fischer	50/250-25-2-01	PRE0186446	01/20/2022
UL AUTOMATION SOFTWARE				
Radiated Software	UL	UL EMC	Ver 9.5, March 06, 2020	
Conducted Software	UL	UL EMC	Ver 17.0, September 18, 2020	
AC Line Conducted Software	UL	UL EMC	Ver 9.5, July 07, 2020	

7. OCCUPIED BANDWIDTH

TEST PROCEDURE

The transmitter output is connected to the spectrum analyzer. The RBW is set to 300Hz at 326.5kHz signal and 5.1kHz at 1.778MHz signal. The VBW is set to 3 times the RBW. The sweep time is coupled. The spectrum analyzer internal 99% bandwidth function is utilized.

Note: Because the measured signal is CW-like, adjusting the RBW per C63.10 would not be practical since measured bandwidth will always follow the RBW and the result will be approximately twice the RBW.

Note that when the EUT was in standby mode the only signal that comes out from the EUT was the intentional charging signal of 326.5kHz. On the other hand, when the EUT was in operational mode there were two signals. One of the intentional charging signal of 326.5kHz and the other intentional charging signal is 1.778MHz.

EUT SETUP

Configuration 1: Low Frequency Charger in standby mode, transmitting low duty cycle CW signal at 326.5kHz test.

Configuration 2: Low Frequency Charger in pairing mode with FSK modulation which occurs over a very short period of time as soon as the watch is placed on the charger.

Configuration 3: Low Frequency Charger in charging mode with signal transmitting at 326.5kHz.

Configuration 4: High Frequency Charger in pairing mode with FSK modulation which occurs over a very short period of time as soon as the watch is placed on the charger.

Configuration 5: High Frequency Charger in charging mode with signal transmitting at 1.778MHz.

RESULTS

7.1.1. CONFIG 1

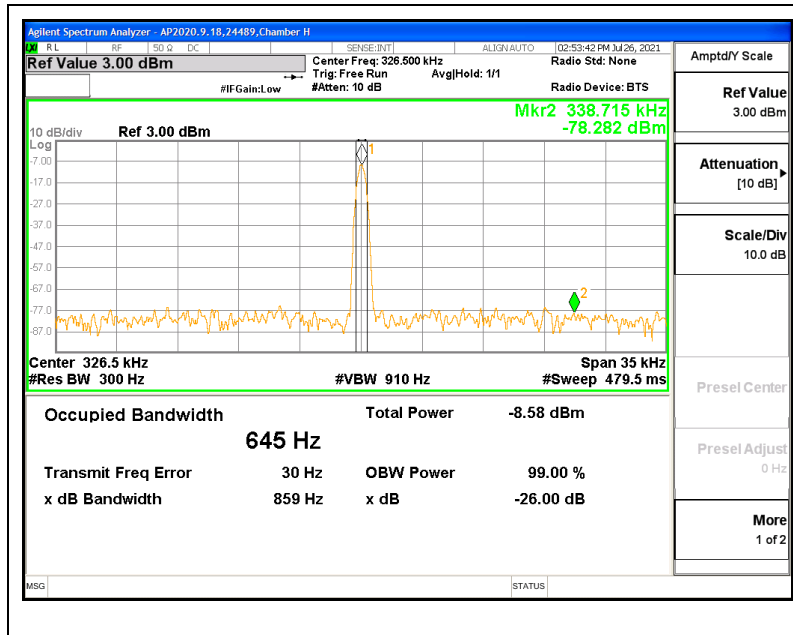

7.1.2. CONFIG 2

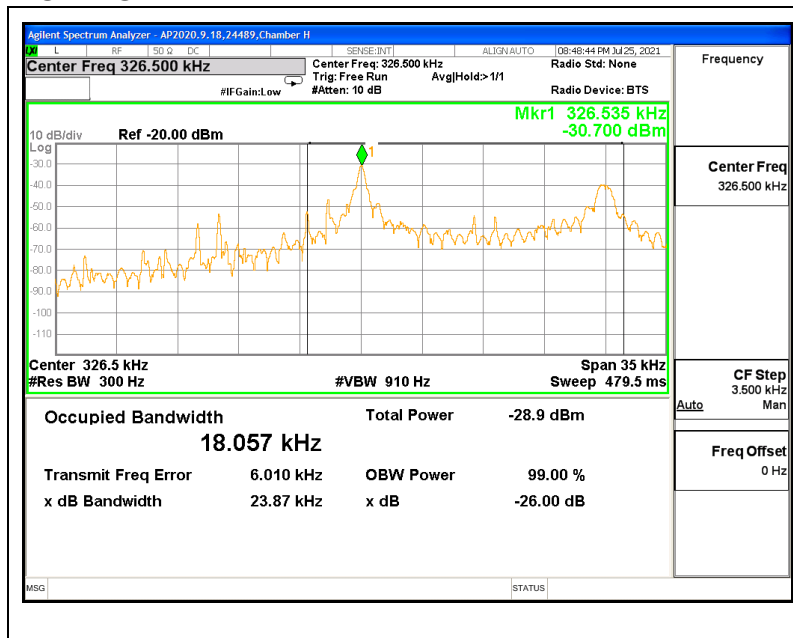

7.1.3. CONFIG 3

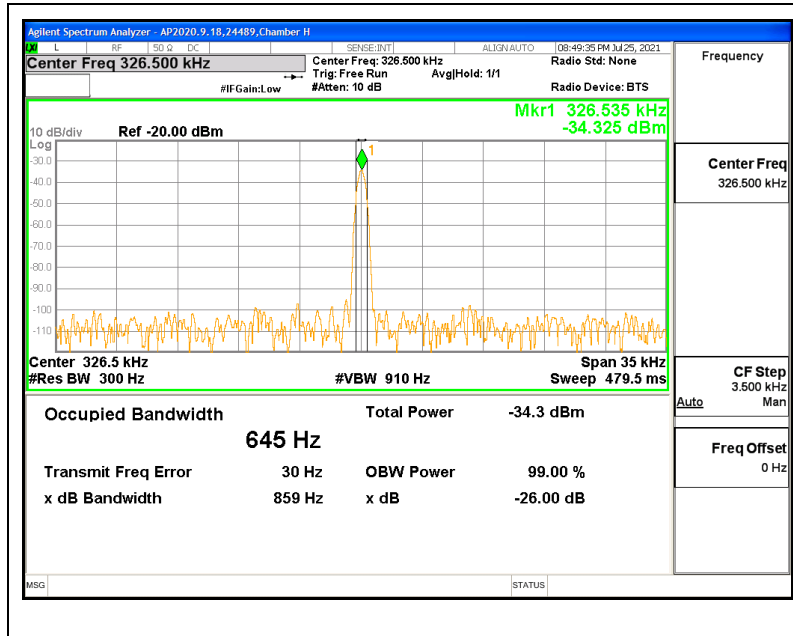

7.1.4. CONFIG 4

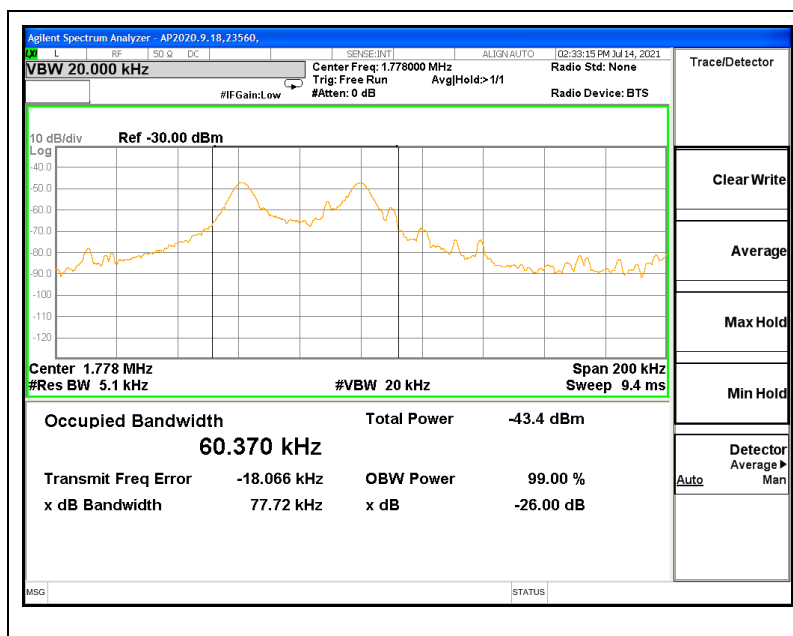

7.1.5. CONFIG 5

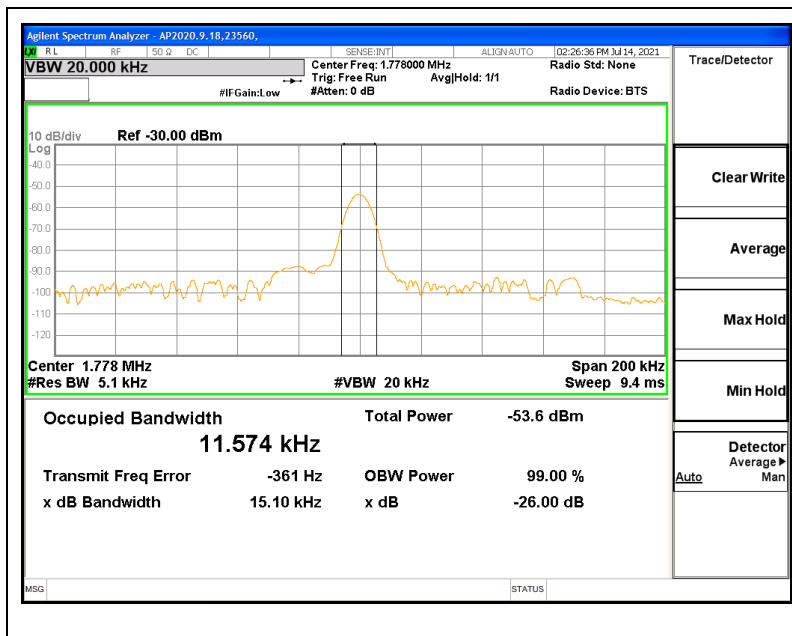

8. RADIATED EMISSION TEST RESULTS

8.1. LIMITS AND PROCEDURE

LIMITS

FCC §15.209 (a)

ICES-001 Section 6.2, IC RSS-216 6.2.2, and IC RSS-GEN Sections 8.9 and 8.10.

Frequency (MHz)	Field Strength (microvolts/meter)	Measurement Distance (m)
0.009–0.490	2400/F(kHz)	300
0.490–1.705	24000/F(kHz)	30
1.705–30.0	30	30
30–88	100	3
88 to 216	150	3
216 to 960	200	3
Above 960 MHz	500	3

Note: The lower limit shall apply at the transition frequency.

ICES-001 Issue 5 Table 2 & Table 4:

Table 2: Magnetic field strength radiated emission limits for induction cooking appliances

Frequency range (MHz)	Quasi-peak, at 3 m distance (dBµA/m)
0.009 – 0.07	69
0.07 – 0.15	69 to 39 *
0.15 – 30	39 to 7 *

* The limit level in dBµA/m decreases linearly with the logarithm of frequency.

Table 4: Electric field strength radiated emission limits for induction cooking appliances

Frequency range (MHz)	OATS or SAC *	OATS or SAC *	FAR *
	10 m measurement distance Quasi-peak (dBµV/m)	3 m measurement distance Quasi-peak (dBµV/m)	3 m measurement distance Quasi-peak (dBµV/m)
30 – 230	30	40	42 to 35**
230 – 1000	37	47	42

Note: The more stringent limit applies at the transition frequency.
 * OATS = open-area test site, SAC = semi-anechoic chamber, FAR = fully-anechoic room (see CSA CISPR 11:19).
 ** The limit level in dBµV/m decreases linearly with the logarithm of frequency.

RESULTS

8.1.1. FCC TX FUNDAMENTAL AND SPURIOUS EMISSIONS FROM 9 kHz TO 30 MHz

STANDBY CONFIGURATION (326.5kHz Frequency)

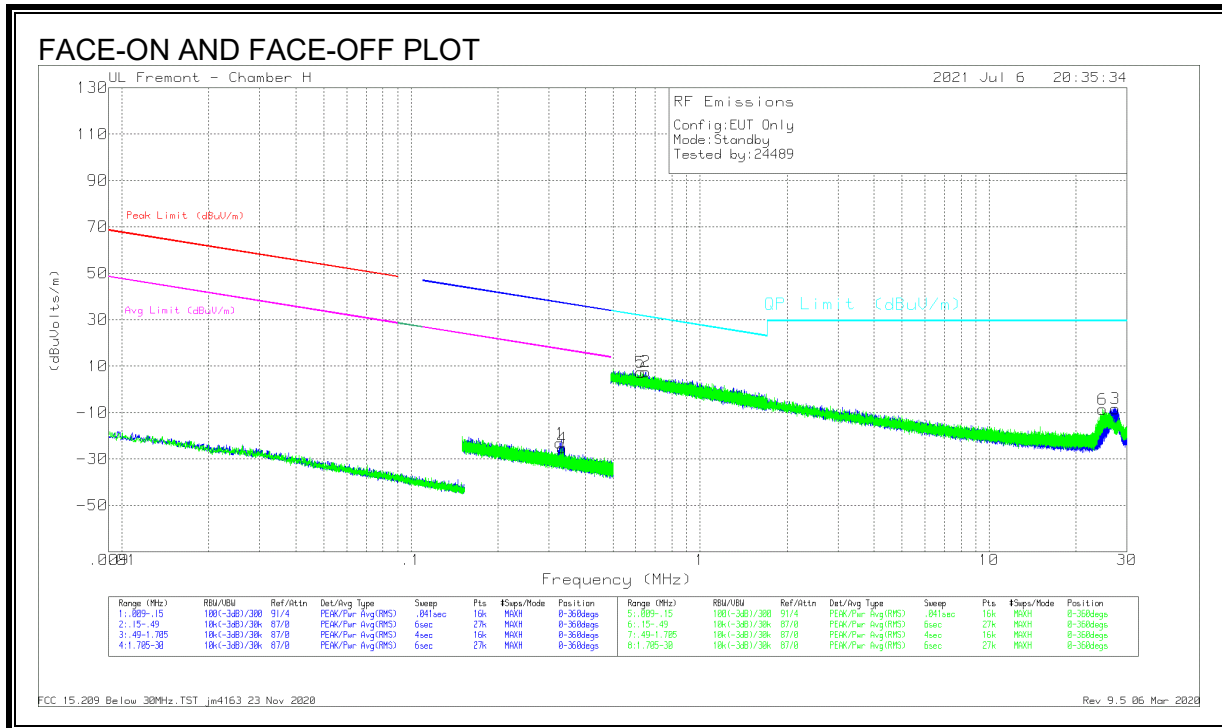

DATA

Marker	Frequency (MHz)	Meter Reading (dBuV)	Det	Loop Antenna (dBm)	Cables (dB)	Dist Corr 300m	Corrected Reading (dBuVolts/m)	Peak Limit (dBuV/m)	Margin (dB)	Avg Limit (dBuV/m)	Margin (dB)	Azimuth (Degs)	Antenna Orientation
1	.327	45.44	Pk	11.3	.1	-80	-23.16	37.29	-60.45	17.29	-40.45	0-360	Face-On
4	.327	43.3	Pk	11.3	.1	-80	-25.3	37.15	-62.45	17.15	-42.45	0-360	Face-Off

Pk - Peak detector

Marker	Frequency (MHz)	Meter Reading (dBuV)	Det	Loop Antenna (dBm)	Cables (dB)	Dist Corr (dB) 40Log	Corrected Reading (dBuVolts/m)	QP Limit (dBuV/m)	Margin (dB)	Azimuth (Degs)	Antenna Orientation
5	.62399	35.95	Pk	11.3	.1	-40	7.35	31.71	-24.36	0-360	Face-Off
2	.64861	36.18	Pk	11.3	.1	-40	7.58	31.37	-23.79	0-360	Face-On
6	24.71489	21.31	Pk	9.4	.7	-40	-8.59	29.5	-38.09	0-360	Face-Off
3	27.39358	22.06	Pk	8.8	.8	-40	-8.34	29.5	-37.84	0-360	Face-On

Pk - Peak detector

OPERATING WITH WATCH at 326.5kHz Frequency

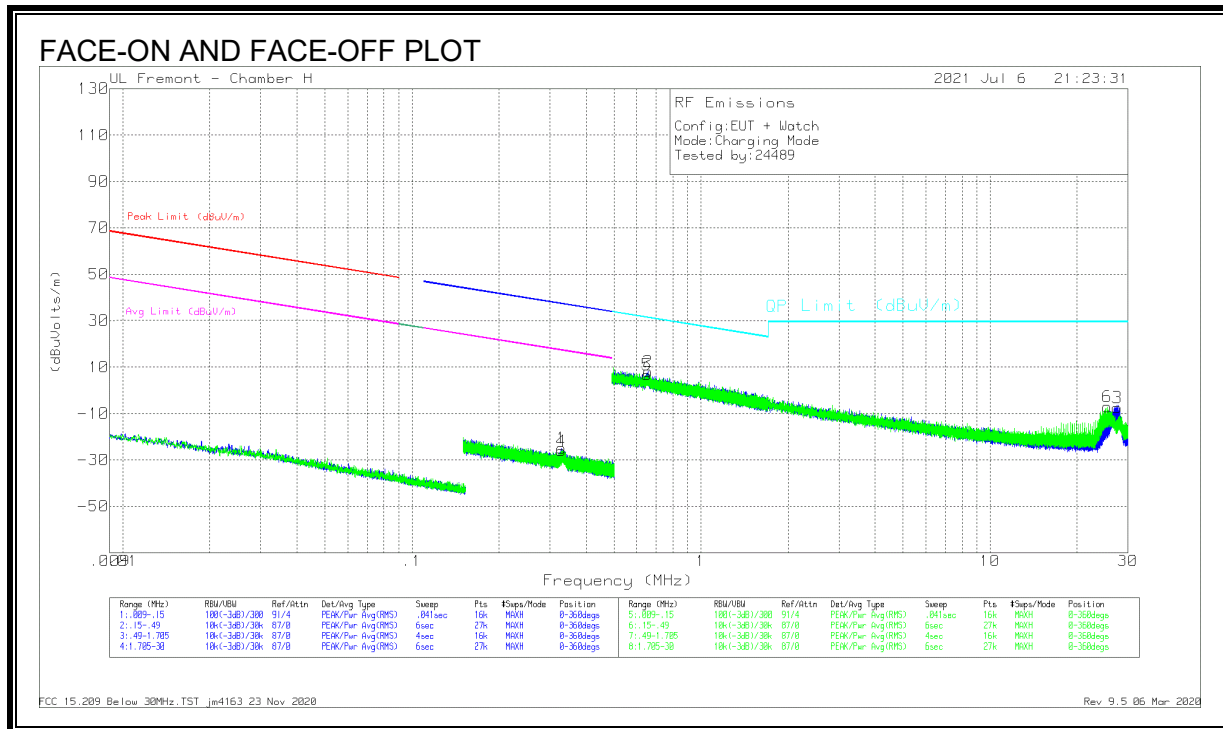

DATA

Marker	Frequency (MHz)	Meter Reading (dBuV)	Det	Loop Antenna (dBm)	Cables (dB)	Dist Corr 300m	Corrected Reading (dBuVolts/m)	Peak Limit (dBuV/m)	Margin (dB)	Avg Limit (dBuV/m)	Margin (dB)	Azimuth (Degs)	Antenna Orientation
4	.32901	42.52	Pk	11.3	.1	-80	-26.08	37.27	-63.35	17.27	-43.35	0-360	Face-Off
1	.32908	43.75	Pk	11.3	.1	-80	-24.85	37.26	-62.11	17.26	-42.11	0-360	Face-On

Pk - Peak detector

Marker	Frequency (MHz)	Meter Reading (dBuV)	Det	Loop Antenna (dBm)	Cables (dB)	Dist Corr (dB) 40Log	Corrected Reading (dBuVolts/m)	QP Limit (dBuV/m)	Margin (dB)	Azimuth (Degs)	Antenna Orientation
5	.6512	35.35	Pk	11.3	.1	-40	6.75	31.34	-24.59	0-360	Face-Off
2	.65614	36.73	Pk	11.3	.1	-40	8.13	31.27	-23.14	0-360	Face-On
6	25.42229	23.05	Pk	9.2	.7	-40	-7.05	29.5	-36.55	0-360	Face-Off
3	27.5665	22.98	Pk	8.8	.8	-40	-7.42	29.5	-36.92	0-360	Face-On

Pk - Peak detector

OPERATING WITH WATCH at 1.778MHz Frequency

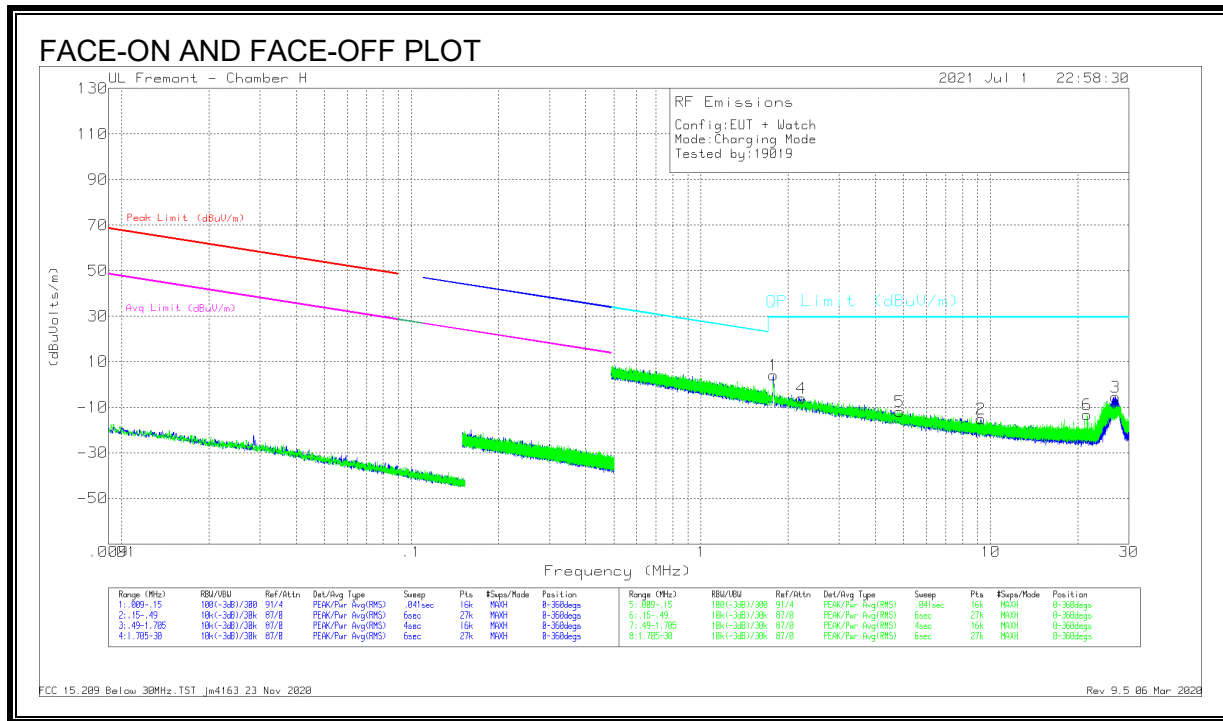

DATA

Marker	Frequency (MHz)	Meter Reading (dBuV)	Det	Loop Antenna (dBm)	Cables (dB)	Dist Corr (dB) 40Log	Corrected Reading (dBuVolts/m)	QP Limit (dBuV/m)	Margin (dB)	Azimuth (Degs)	Antenna Orientation
1	1.77731	32.43	Pk	11.4	.2	-40	4.03	29.5	-25.47	0-360	Face-On
4	2.22271	22.28	Pk	11.4	.2	-40	-6.12	29.5	-35.62	0-360	Face-Off
5	4.84166	16.54	Pk	11.3	.3	-40	-11.86	29.5	-41.36	0-360	Face-Off
2	9.25479	13.64	Pk	10.8	.5	-40	-15.06	29.5	-44.56	0-360	Face-On
6	21.55517	16.2	Pk	9.9	.7	-40	-13.2	29.5	-42.7	0-360	Face-Off
3	27.00582	24.89	Pk	8.9	.8	-40	-5.41	29.5	-34.91	0-360	Face-On

Pk - Peak detector

8.1.2. IC / ICES-001 TX FUNDAMENTAL AND SPURIOUS EMISSIONS FROM 9 kHz TO 30 MHz

STANDBY CONFIGURATION at 326.5kHz Frequency

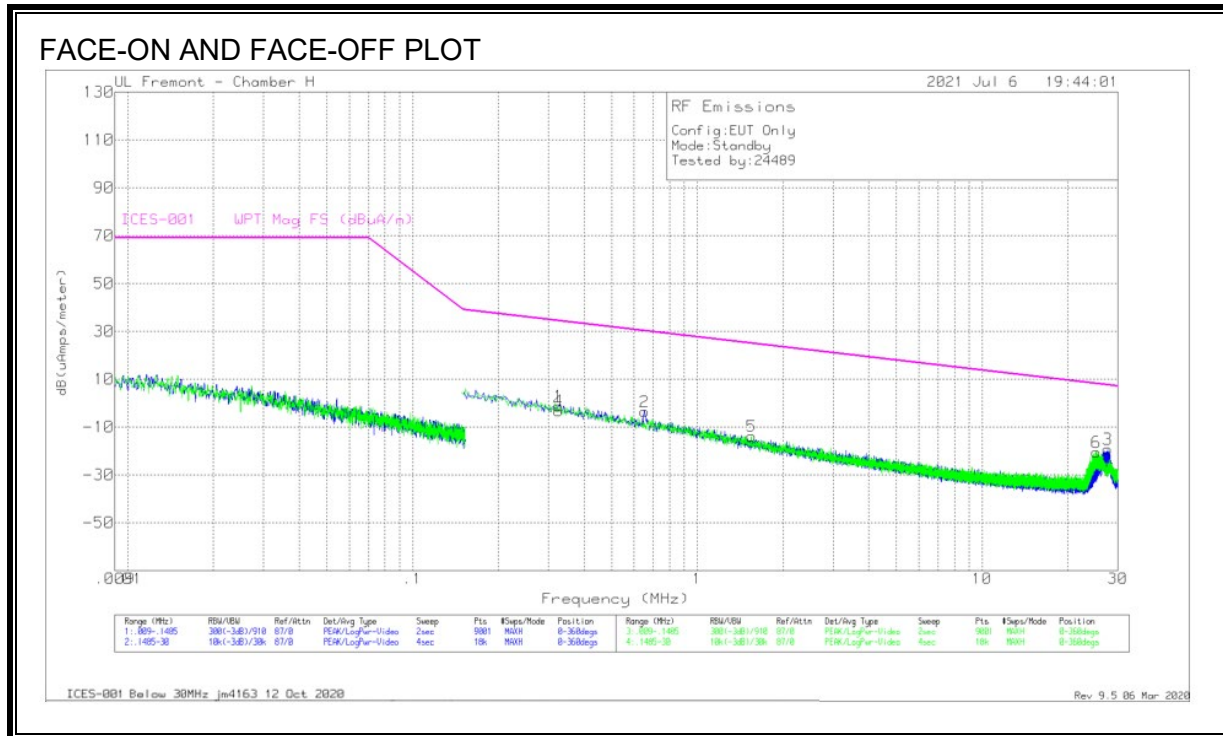

DATA

Marker	Frequency (MHz)	Meter Reading (dBuV)	Det	Loop Antenna (dB/m)	Cables (dB)	Corrected Reading dB(uAmps/meter)	ICES-001 WPT Mag FS (dBUA/m)	Margin (dB)	Azimuth (Degs)	Antenna Orientation
1	.32591	38.86	Pk	-40.2	.1	-1.24	34.31	-35.55	0-360	Face-On
4	.32591	36.89	Pk	-40.2	.1	-3.21	34.31	-37.52	0-360	Face-Off
2	.65253	36.42	Pk	-40.1	.1	-3.58	30.12	-33.7	0-360	Face-On
5	1.54951	26.09	Pk	-40.1	.2	-13.81	24.9	-38.71	0-360	Face-Off
6	25.19259	20.89	Pk	-42.1	.7	-20.51	8.05	-28.56	0-360	Face-Off
3	27.64146	22.66	Pk	-42.7	.8	-19.24	7.49	-26.73	0-360	Face-On

Pk - Peak detector

OPERATING WITH WATCH at 326.5kHz Frequency

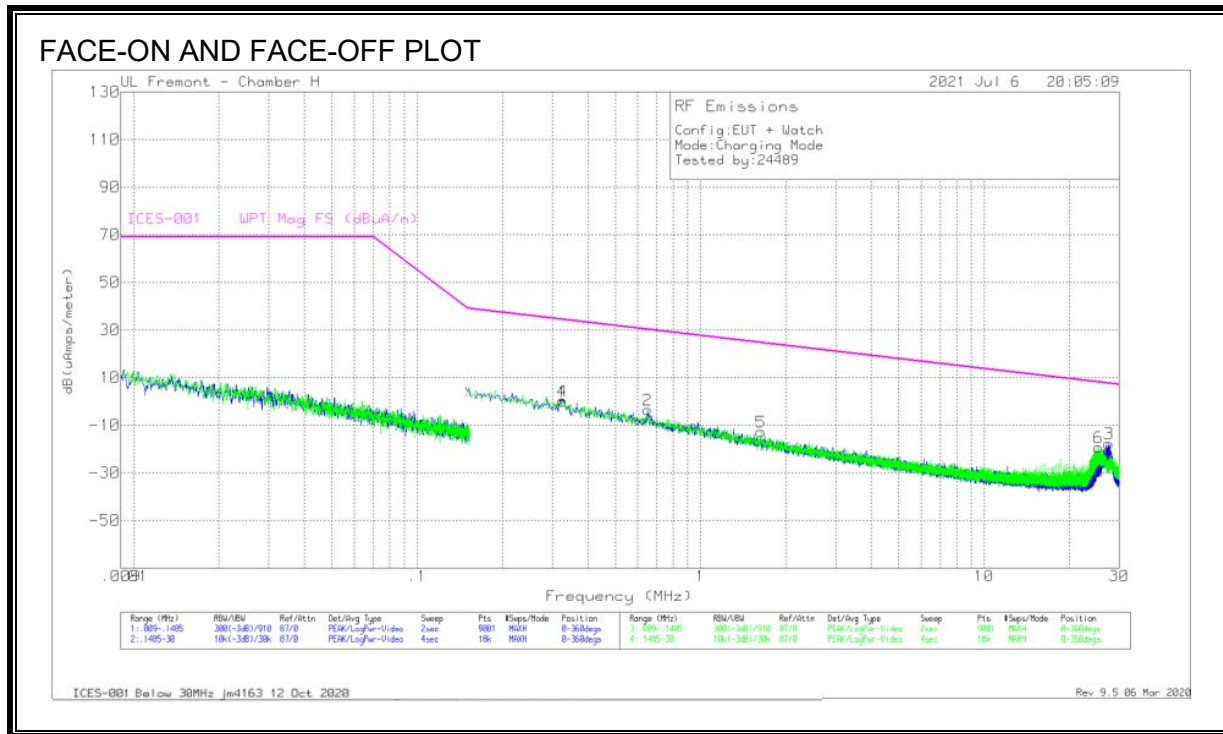

DATA

Marker	Frequency (MHz)	Meter Reading (dBuV)	Det	Loop Antenna (dB/m)	Cables (dB)	Corrected Reading dB(uAmps/meter)	ICES-001 WPT Mag FS (dBuA/m)	Margin (dB)	Azimuth (Degs)	Antenna Orientation
1	.32591	40.02	Pk	-40.2	.1	-.08	34.31	-34.39	0-360	Face-On
4	.32591	40.23	PK	-40.2	.1	.13	34.31	-34.18	0-360	Face-Off
2	.65087	36.45	Pk	-40.1	.1	-3.55	30.14	-33.69	0-360	Face-On
5	1.63241	27.12	Pk	-40.1	.2	-12.78	24.58	-37.36	0-360	Face-Off
6	25.30202	22.22	Pk	-42.2	.7	-19.28	8.03	-27.31	0-360	Face-Off
3	27.54363	24.19	Pk	-42.7	.8	-17.71	7.52	-25.23	0-360	Face-On

Pk - Peak detector

OPERATING WITH WATCH at 1.778MHz Frequency

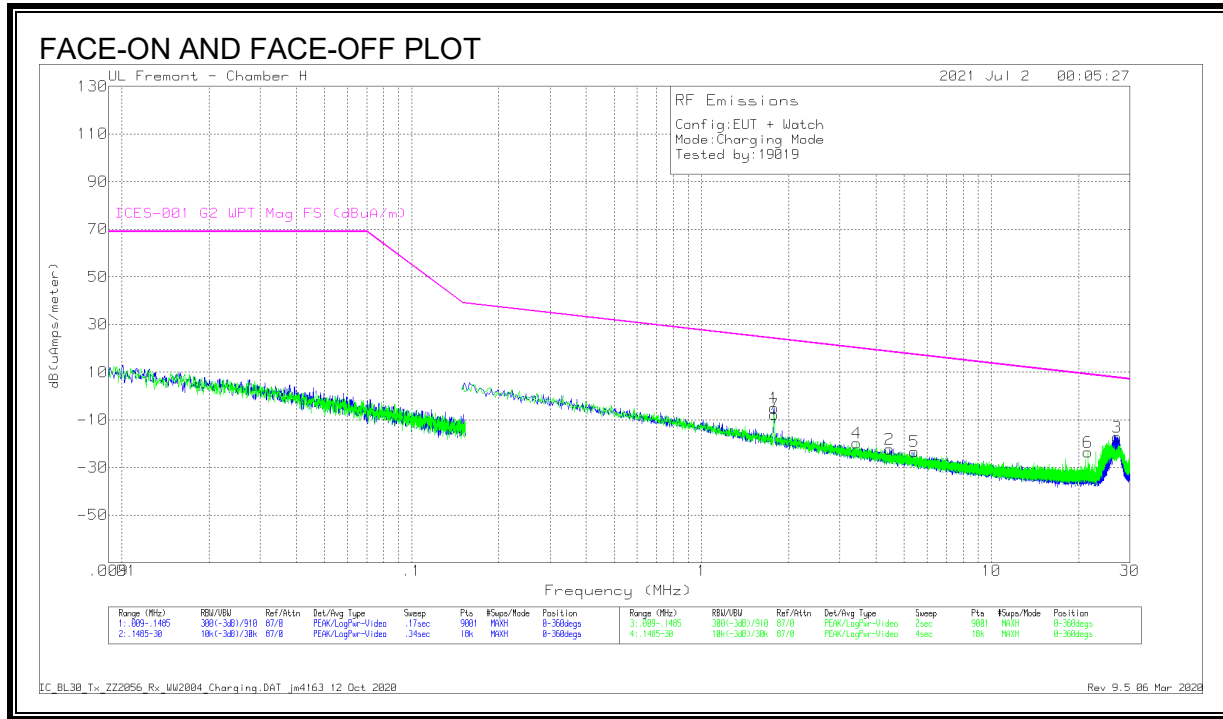

DATA

Marker	Frequency (MHz)	Meter Reading (dBuV)	Det	Loop Antenna (dB/m)	Cables (dB)	Corrected Reading dB(uAmps/meter)	ICES-001 WPT Mag FS (dBuA/m)	Margin (dB)	Azimuth (Degs)	Antenna Orientation
1	1.77830	34.88	Pk	-40.1	.2	-5.02	24.07	-29.09	0-360	Face-On
7	1.77830	31.98	Pk	-40.1	.2	-7.92	24.06	-31.98	0-360	Face-Off
4	3.42139	19.93	Pk	-40.1	.3	-19.87	20.11	-39.98	0-360	Face-Off
2	4.45598	17.48	Pk	-40	.3	-22.22	18.52	-40.74	0-360	Face-On
5	5.41099	16.46	Pk	-40.1	.4	-23.24	17.34	-40.58	0-360	Face-Off
6	21.55328	17.12	Pk	-41.5	.7	-23.68	9	-32.68	0-360	Face-Off
3	27.10095	24.52	Pk	-42.5	.8	-17.18	7.61	-24.79	0-360	Face-On

Pk - Peak detector

8.1.3. FCC TX SPURIOUS EMISSION 30 TO 1000 MHz

STANDBY CONFIGURATION at 326.5kHz Frequency

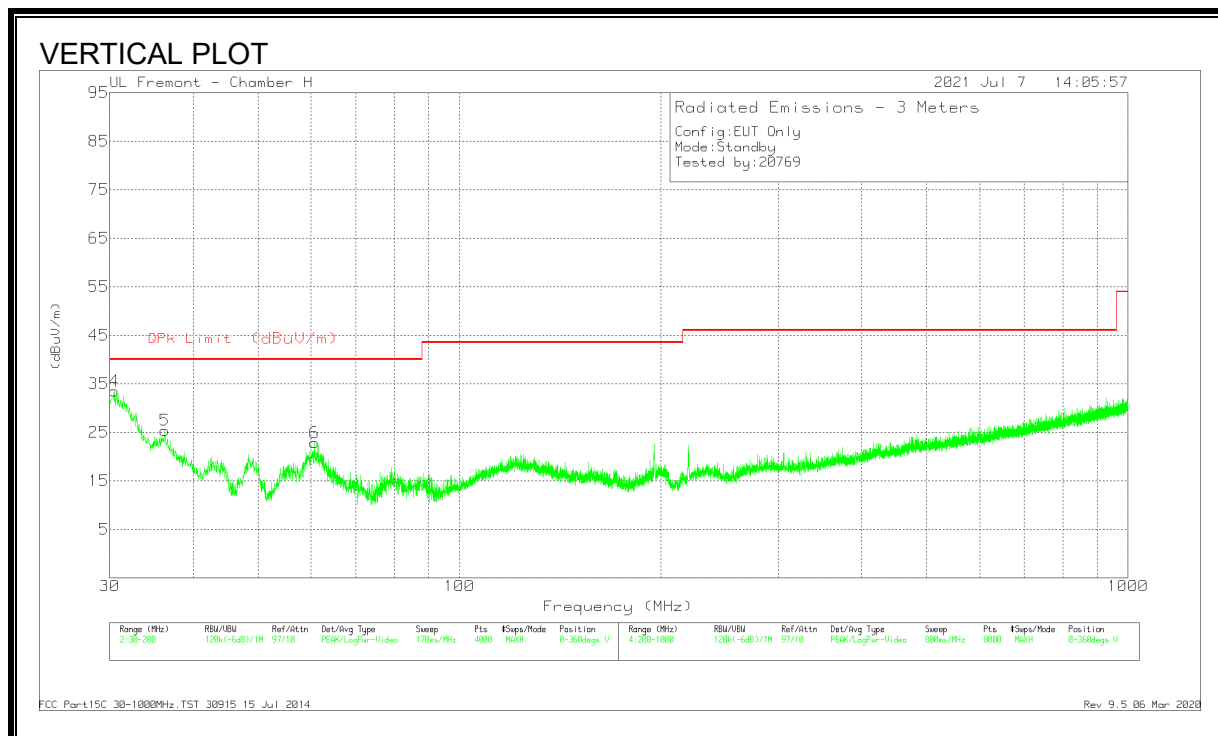
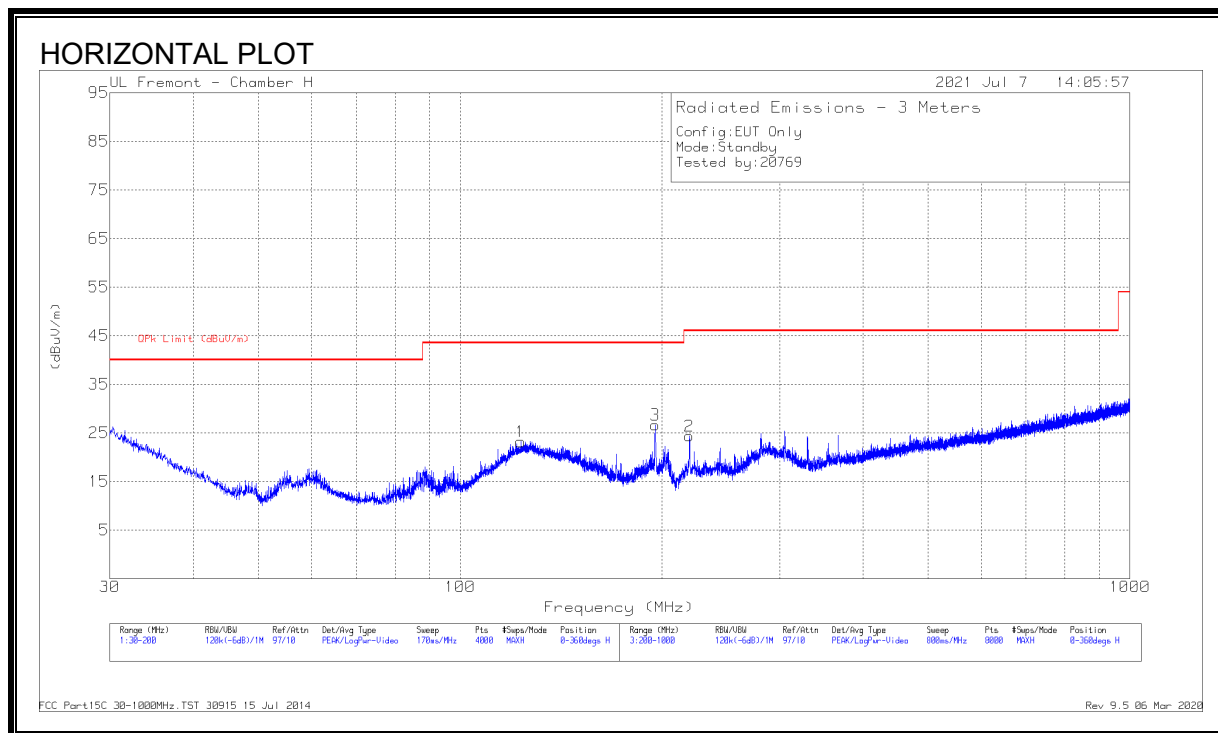

DATA

Marker	Frequency (MHz)	Meter Reading (dBuV)	Det	AF T243 (dB/m)	Amp/Cbl (dB)	Corrected Reading (dBuV/m)	QPk Limit (dBuV/m)	Margin (dB)	Azimuth (Degs)	Height (cm)	Polarity
1	* 123.2472	28.56	Qp	20	-30.5	18.06	43.52	-25.46	192	372	H
4	30.1885	27.02	Qp	27.9	-31.4	23.52	40	-16.48	91	331	V
5	33.1464	24.42	Qp	25.7	-31.3	18.82	40	-21.18	203	378	V
6	59.7985	31.31	Qp	13.7	-31	14.01	40	-25.99	265	331	V
3	195.5342	36.36	Qp	18.4	-29.9	24.86	43.52	-18.66	9	136	H
2	220.0104	37.02	Qp	17.2	-29.9	24.32	46.02	-21.7	21	123	H

* - indicates frequency in CFR47 Pt 15 / IC RSS-Restricted Band
 Qp - Quasi-Peak detector

OPERATING WITH WATCH at 326.5kHz Frequency

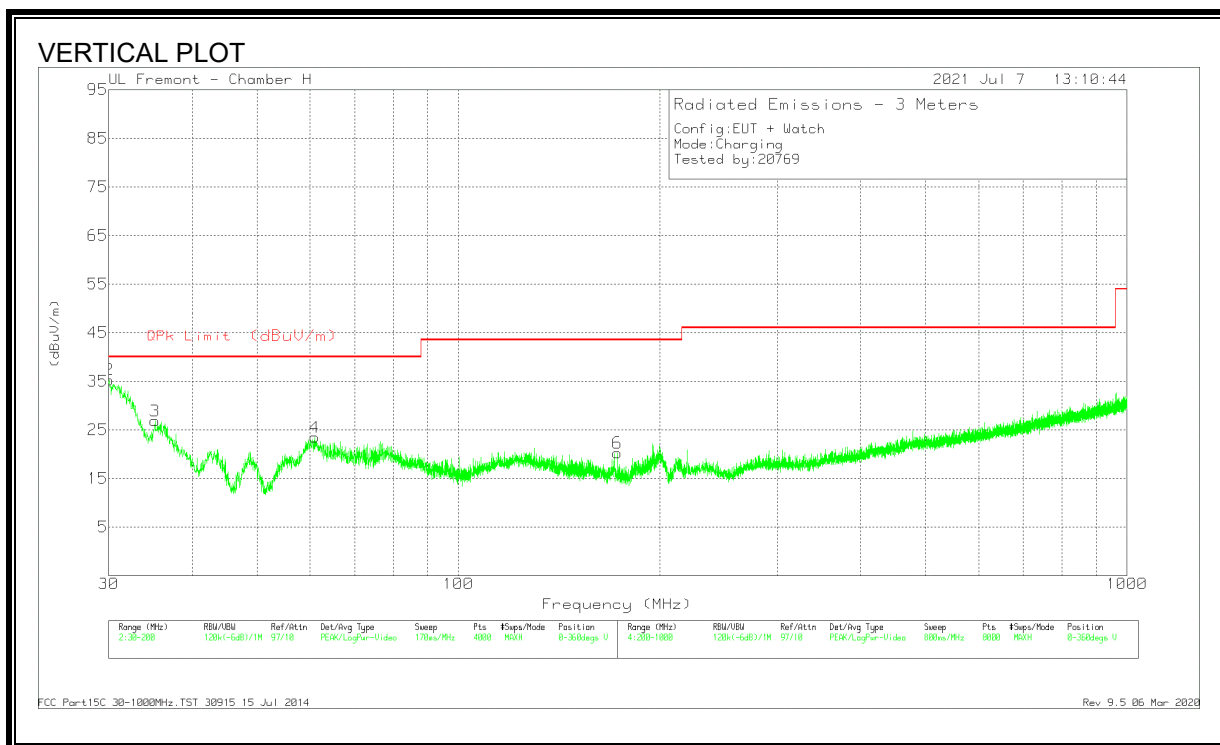
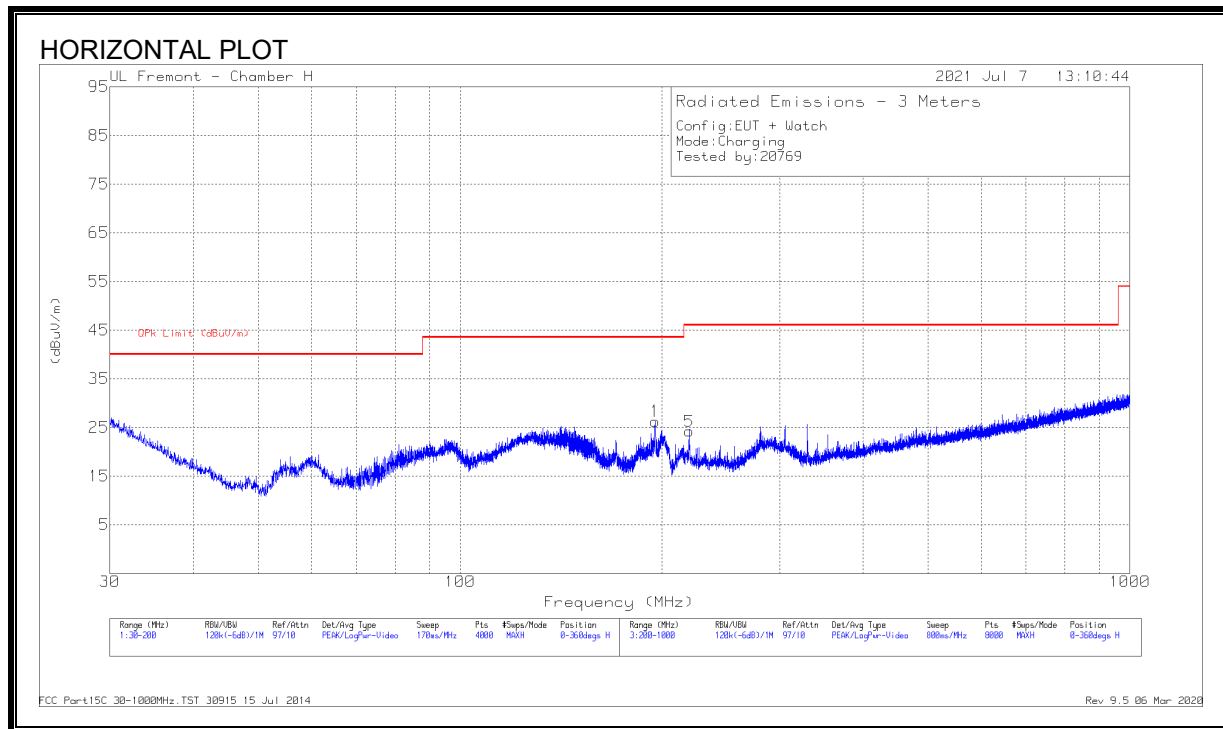

DATA

Marker	Frequency (MHz)	Meter Reading (dBuV)	Det	AF T243 (dB/m)	Amp/Cbl (dB)	Corrected Reading (dBuV/m)	QPk Limit (dBuV/m)	Margin (dB)	Azimuth (Degs)	Height (cm)	Polarity
6	* 170.4613	24.99	Qp	17.9	-30.2	12.69	43.52	-30.83	358	357	V
2	30.3813	35.11	Qp	27.7	-31.4	31.41	40	-8.59	17	101	V
3	36.6916	25.53	Qp	22.8	-31.3	17.03	40	-22.97	347	300	V
4	59.7581	35.52	Qp	13.7	-31	18.22	40	-21.78	264	314	V
1	195.2424	37.07	Qp	18.3	-30	25.37	43.52	-18.15	7	186	H
5	219.7645	36.89	Qp	17.2	-29.9	24.19	46.02	-21.83	232	108	H

* - indicates frequency in CFR47 Pt 15 / IC RSS-Restricted Band
 Qp - Quasi-Peak detector

OPERATING WITH WATCH at 1.778MHz Frequency

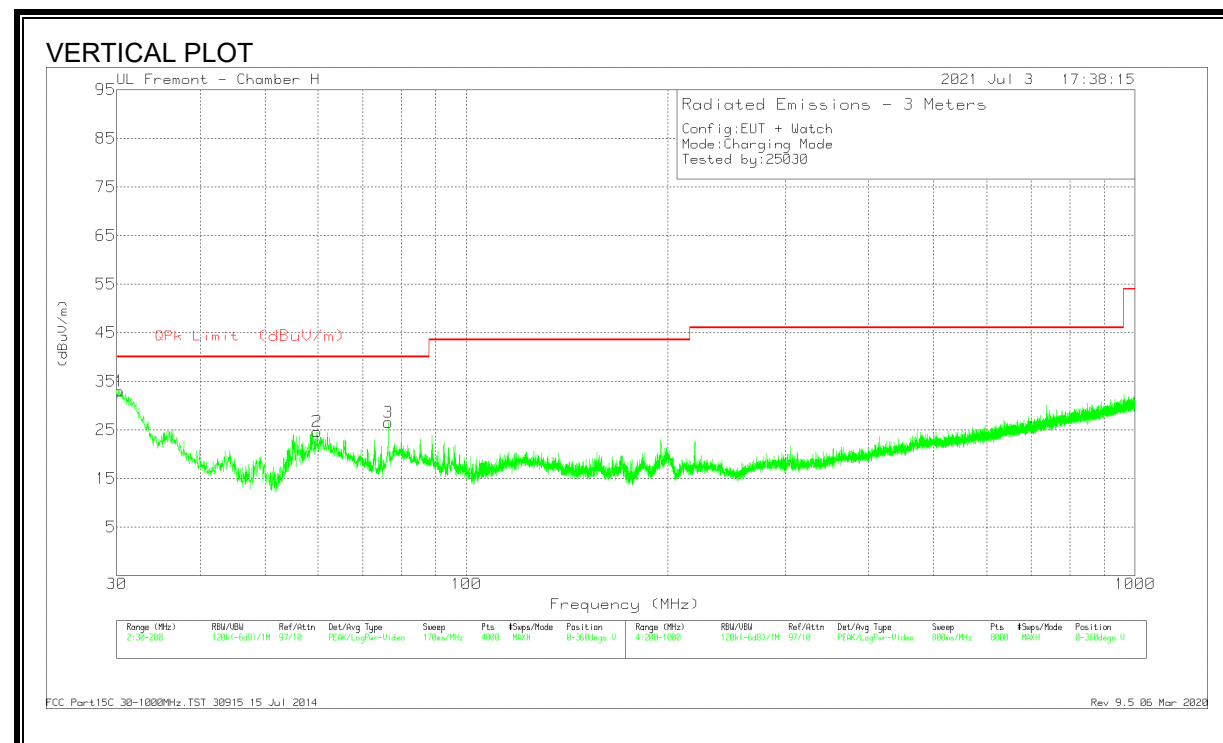
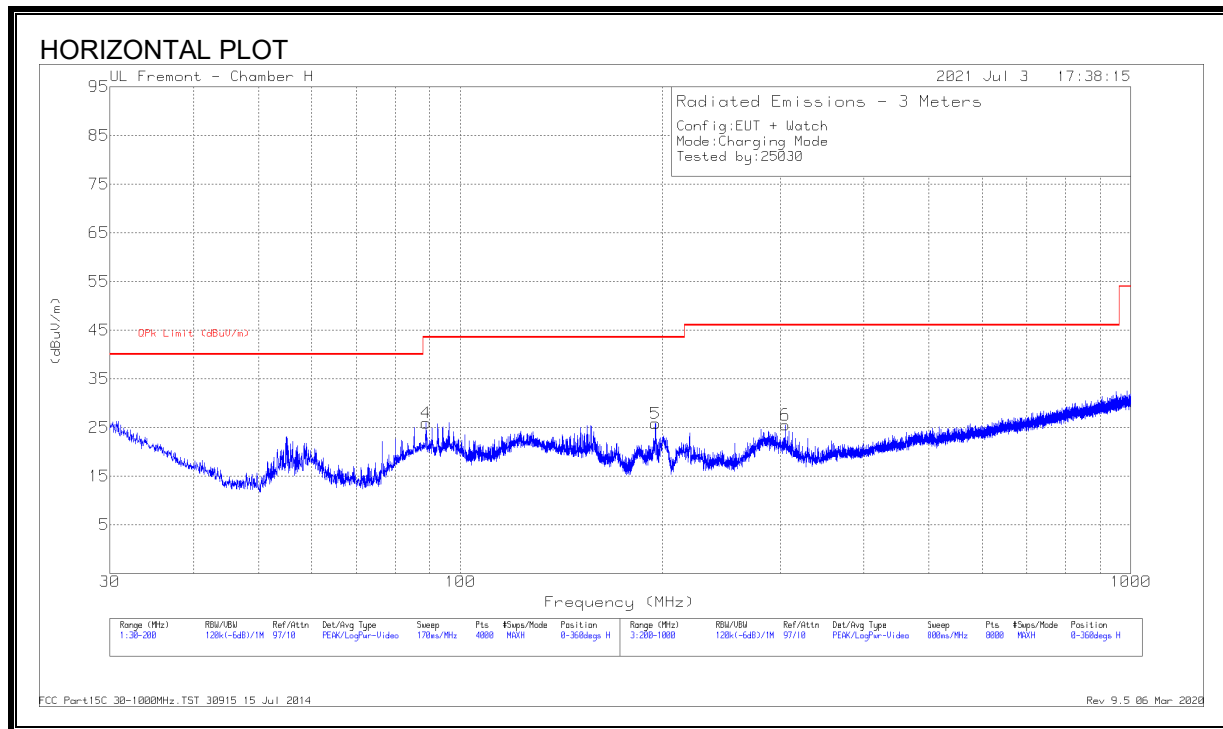

DATA

Marker	Frequency (MHz)	Meter Reading (dBuV)	Det	AF T185 (dB/m)	Amp/Cbl (dB)	Corrected Reading (dBuV/m)	QPk Limit (dBuV/m)	Margin (dB)	Azimuth (Degs)	Height (cm)	Polarity
1	30.441	33.34	Qp	27.8	-31.4	29.74	40	-10.26	116	100	V
2	55.1	39.47	Qp	13.4	-31.1	21.77	40	-18.23	110	126	V
3	76.435	41.25	Qp	14.2	-30.9	24.55	40	-15.45	241	111	V
4	88.89	42.43	Qp	13.6	-30.8	25.23	43.52	-18.29	326	238	H
5	195.26	36.9	Qp	18.3	-30	25.2	43.52	-18.32	0	167	H
6	305.1187	33.25	Qp	19.9	-29.4	23.75	46.02	-22.27	209	101	H

Qp - Quasi-Peak detector

8.1.4. IC / ICES-001 TX SPURIOUS EMISSION 30 TO 1000 MHz

STANDBY CONFIGURATION at 326.5kHz Frequency

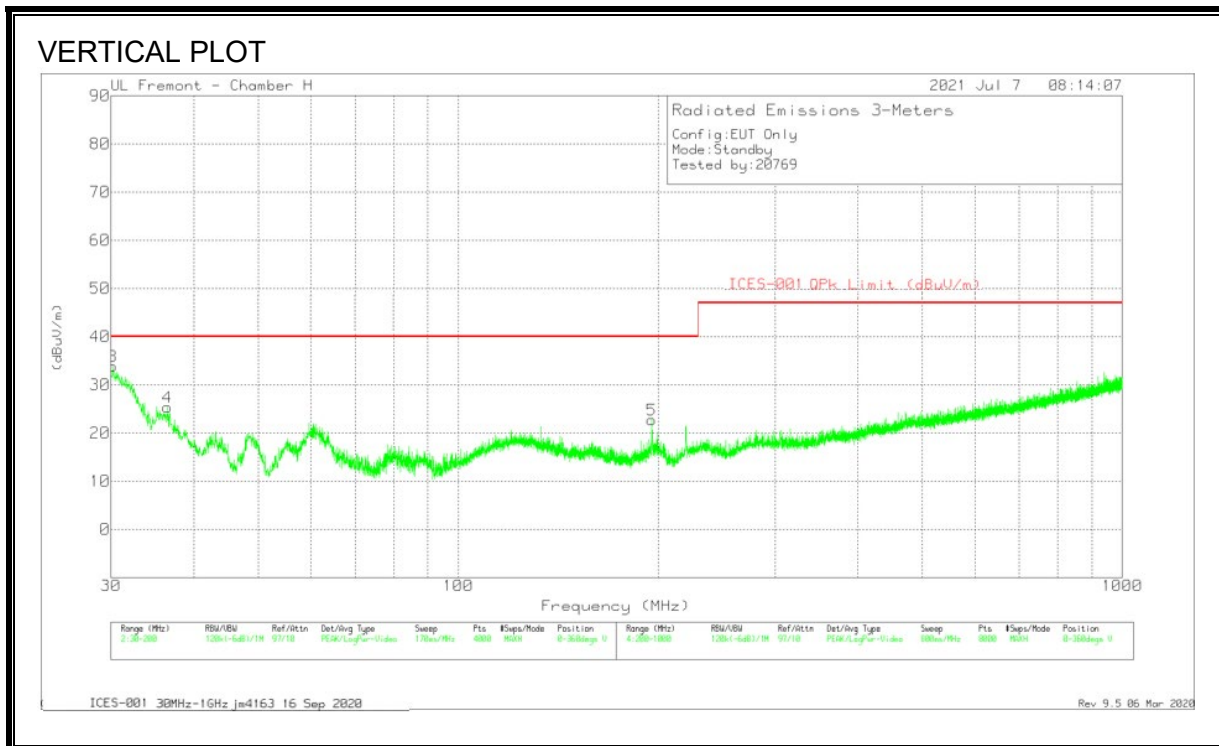
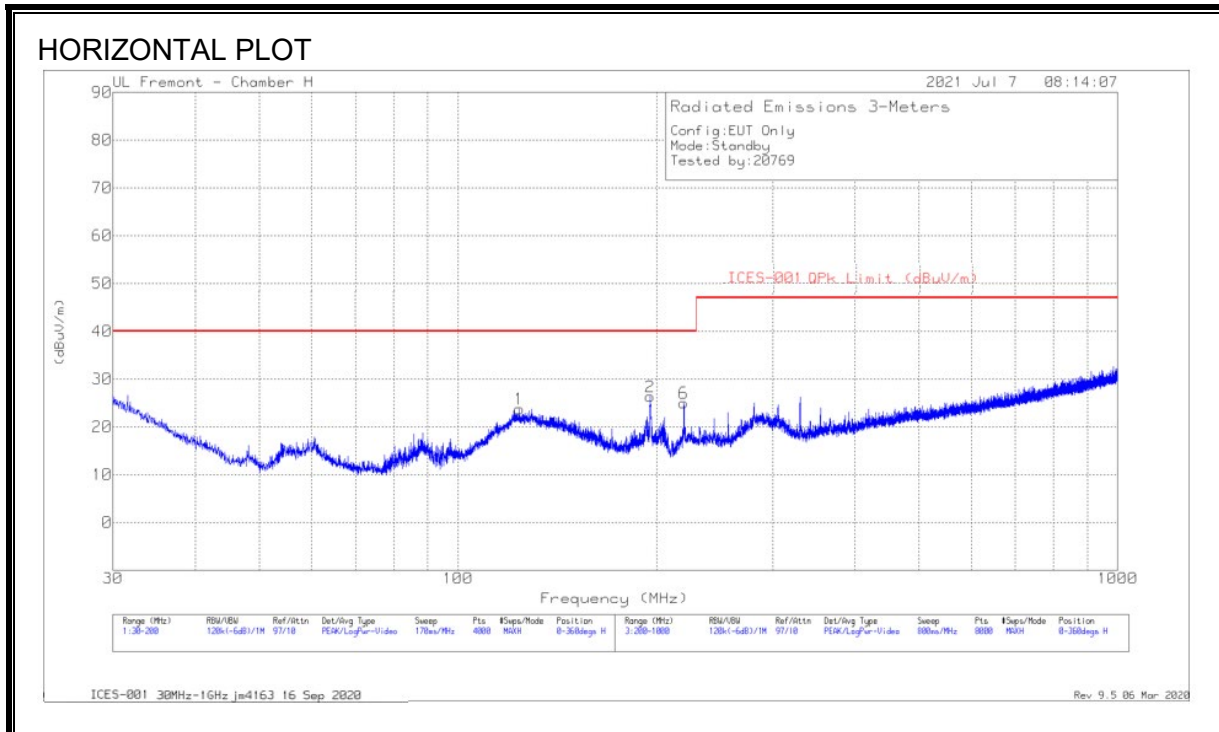

DATA

Marker	Frequency (MHz)	Meter Reading (dBuV)	Det	AF T243 (dB/m)	Amp/Cbl (dB)	Corrected Reading (dBuV/m)	ICES-001 Limit (dBuV/m)	Margin (dB)	Azimuth (Degs)	Height (cm)	Polarity
3	30.5573	26.05	Qp	27.6	-31.4	22.25	40	-17.75	18	396	V
4	35.2063	24.04	Qp	24	-31.3	16.74	40	-23.26	17	387	V
1	123.1275	28.83	Qp	20	-30.5	18.33	40	-21.67	211	334	H
2	195.5968	36.1	Qp	18.4	-29.9	24.6	40	-15.4	12	135	H
5	195.6964	31.59	Qp	18.4	-29.9	20.09	40	-19.91	22	148	V
6	219.9106	35.5	Qp	17.2	-29.9	22.8	40	-17.2	239	146	H

Qp - Quasi-Peak detector

OPERATING WITH WATCH at 326.5kHz Frequency

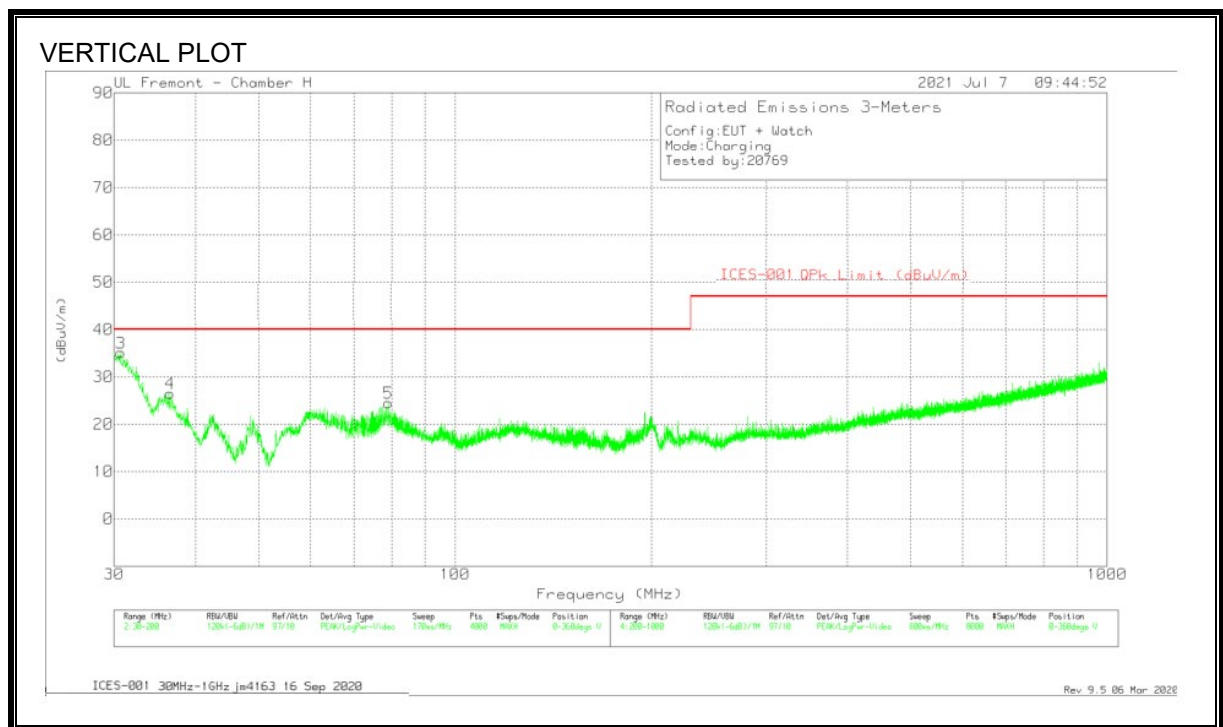
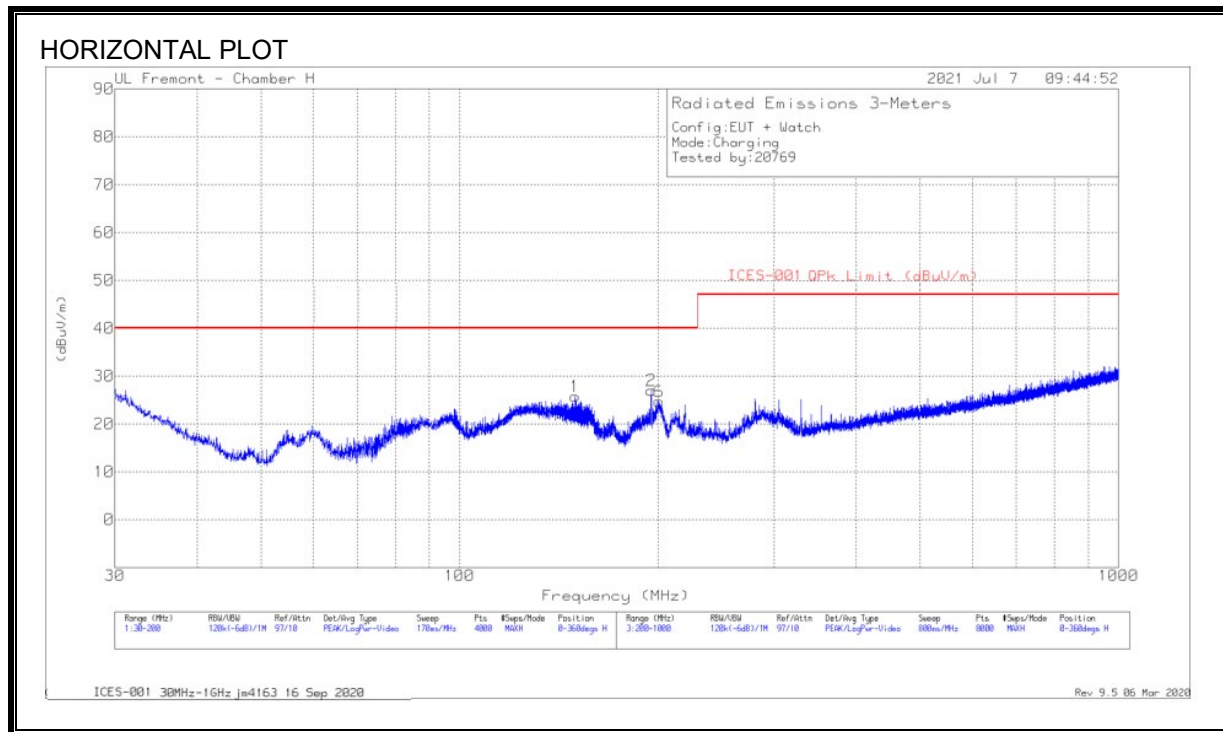

DATA

Marker	Frequency (MHz)	Meter Reading (dBUV)	Det	AF T243 (dB/m)	Amp/Cbl (dB)	Corrected Reading (dBUV/m)	ICES-001 Limit (dBUV/m)	Margin (dB)	Azimuth (Degs)	Height (cm)	Polarity
3	30.6777	35.06	Qp	27.5	-31.4	31.16	40	-8.84	95	100	V
4	36.9194	25.22	Qp	22.7	-31.3	16.62	40	-23.38	34	371	V
5	77.3794	27.11	Qp	14	-30.9	10.21	40	-29.79	225	323	V
1	150.8487	29.79	Qp	18.6	-30.3	18.09	40	-21.91	219	349	H
2	195.4415	37.06	Qp	18.4	-30	25.46	40	-14.54	2	166	H
6	200.4554	32.16	Qp	19.3	-30	21.46	40	-18.54	10	128	H

Qp - Quasi-Peak detector

OPERATING WITH WATCH at 1.778MHz Frequency

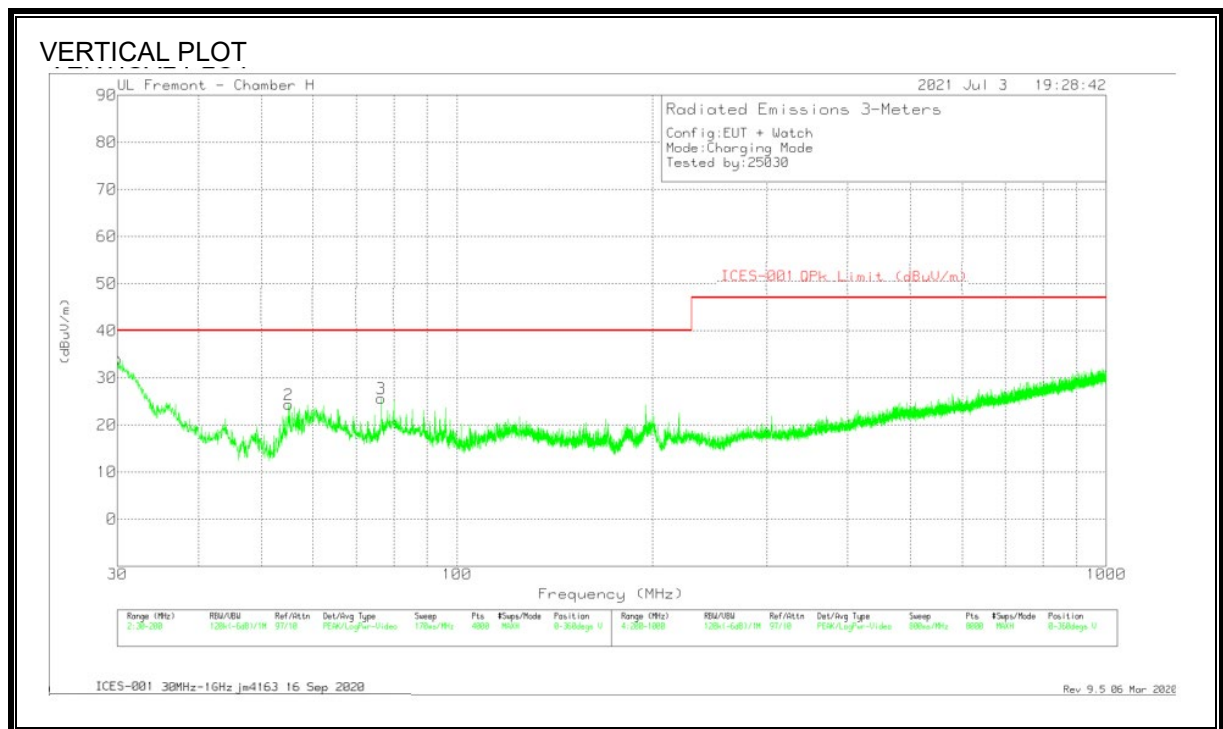
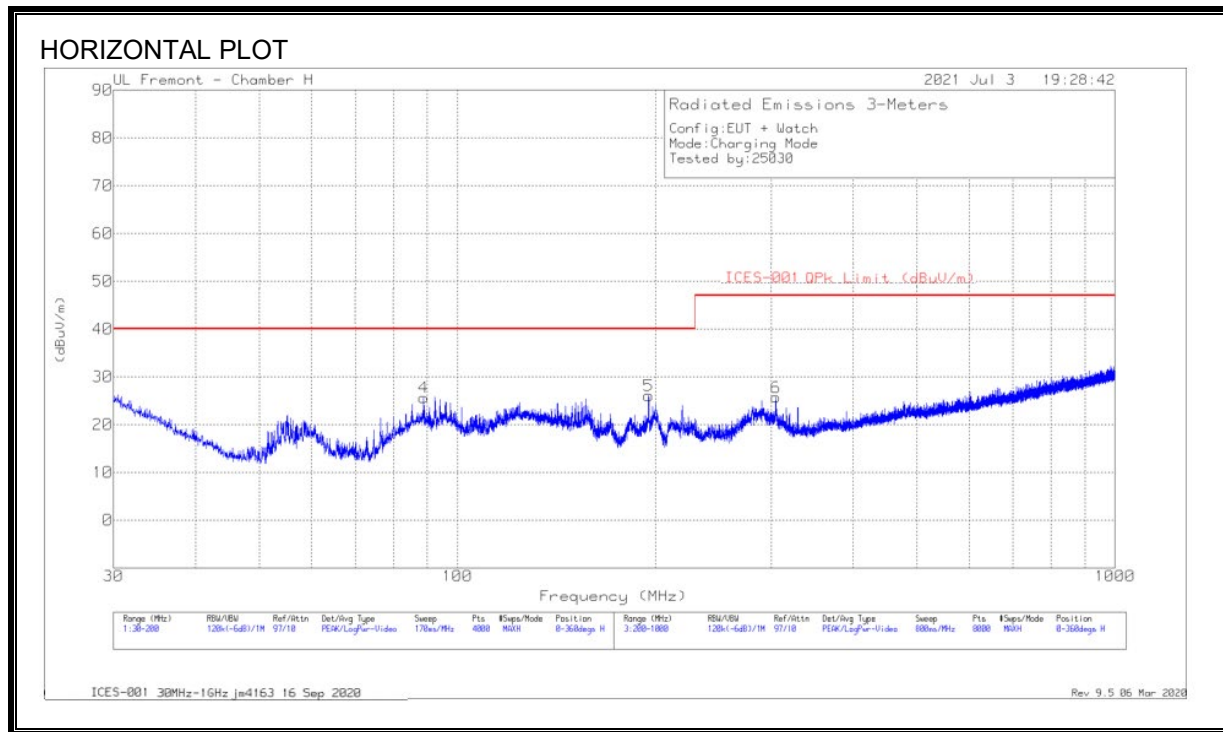

DATA

Marker	Frequency (MHz)	Meter Reading (dBuV)	Det	AF T185 (dB/m)	Amp/Cbl (dB)	Corrected Reading (dBuV/m)	ICES-001 Limit (dBuV/m)	Margin (dB)	Azimuth (Degs)	Height (cm)	Polarity
1	30.423	33.32	Qp	27.8	-31.4	29.72	40	-10.28	52	106	V
2	55.1265	38.95	Qp	13.4	-31.1	21.25	40	-18.75	261	153	V
3	76.424	40.81	Qp	14.2	-30.9	24.11	40	-15.89	230	112	V
4	88.885	40.83	Qp	13.6	-30.8	23.63	40	-16.37	330	392	H
5	195.36	36.81	Qp	18.3	-30	25.11	40	-14.89	5	173	H
6	305.2637	32.34	Qp	19.9	-29.4	22.84	47	-24.16	33	108	H

Qp - Quasi-Peak detector

9. AC POWER LINE CONDUCTED EMISSIONS

LIMITS

FCC §15.207 (a)

RSS-Gen 8.8

Frequency of Emission (MHz)	Conducted Limit (dBµV)	
	Quasi-peak	Average
0.15-0.5	66 to 56 *	56 to 46 *
0.5-5	56	46
5-30	60	50

*Decreases with the logarithm of the frequency.

ICES-001 Issue 5 Table 1:

Table 1: Conducted emission limits for induction cooking appliances (AC mains terminals)

Frequency range (MHz)	Appliances rated 100 V, without an earth connection	Appliances rated 100 V, without an earth connection	All other appliances	All other appliances
	Quasi-peak (dBµV)	Average (dBµV)	Quasi-peak (dBµV)	Average (dBµV)
0.009 – 0.05	122	—	110	—
0.05 – 0.15	102 to 92 *	—	90 to 80 *	—
0.15 – 0.5	72 to 62 *	62 to 52 *	66 to 56 *	56 to 46 *
0.5 – 5	56	46	56	46
5 – 30	60	50	60	50

Note: The more stringent limit applies at transition frequencies.
 * The limit level in dBµV decreases linearly with the logarithm of frequency.

TEST PROCEDURE

The EUT is placed on a non-conducting table 40 cm from the vertical ground plane and 80 cm above the horizontal ground plane. The EUT is configured in accordance with ANSI C63.10.

The receiver is set to a resolution bandwidth of 9 kHz. Peak detection is used unless otherwise noted as quasi-peak or average.

Line conducted data is recorded for both NEUTRAL and HOT lines.

RESULTS

9.1.1. STANDBY MODE POWERED BY AC/DC ADAPTER

LINE 1 RESULTS

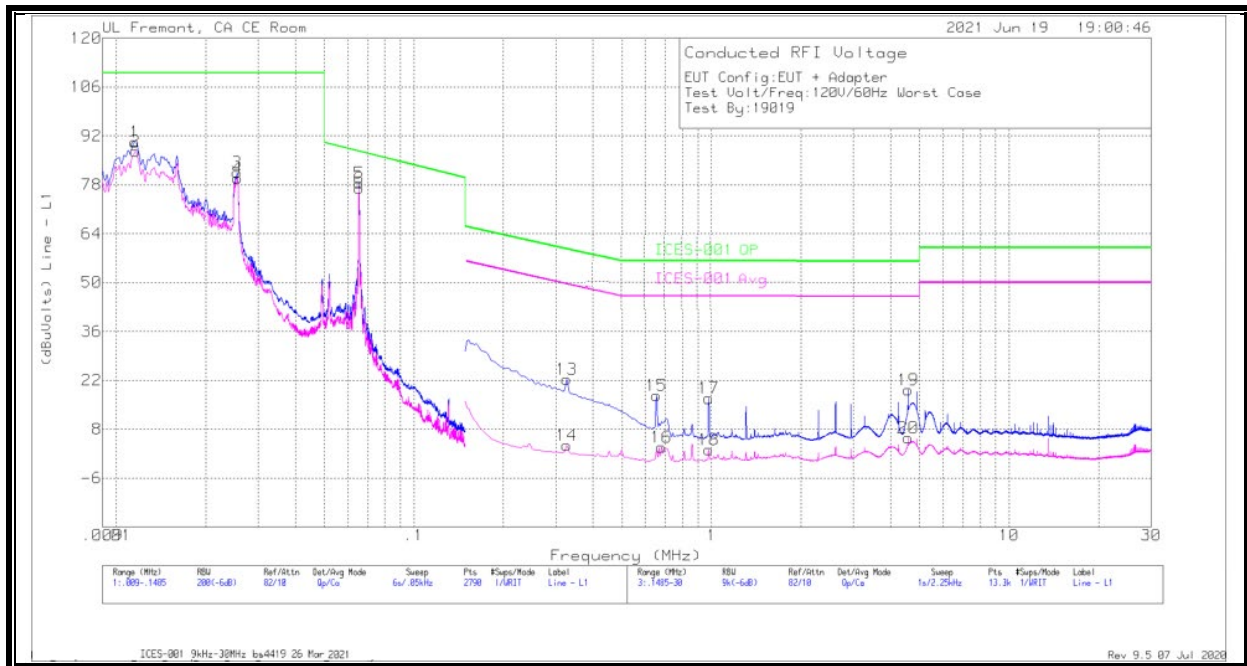

WORST EMISSIONS

Range 1: Line - L1 .009 - 30MHz												
Marker	Frequency (MHz)	Meter Reading (dBuV)	Det	PRE0186446 LISN09(L L1).r	LC Cables C1&C3 dB	TekBox Limiter TBFL1 Model 207	Corrected Reading (dBuVolts)	ICES-001 Class QP	Margin (dB)	ICES-001 Class B Avg	Margin (dB)	
1	.01155	74.01	Qp	3.8	0	12.4	90.21	110	-19.79	-	-	
2	.0116	71.41	Ca	3.7	0	12.4	87.51	-	-	-	-	
3	.0255	68.48	Qp	1.1	0	12	81.58	110	-28.42	-	-	
4	.02555	66.78	Ca	1.1	0	12	79.88	-	-	-	-	
5	.0655	67.54	Qp	.2	0	10.8	78.54	87.52	-8.98	-	-	
6	.06555	66.01	Ca	.2	0	10.8	77.01	-	-	-	-	
13	.32625	13	Qp	0	0	9.3	22.3	59.52	-37.22	-	-	
14	.32625	-5.94	Ca	0	0	9.3	3.36	-	-	49.55	-46.19	
15	.6525	8.27	Qp	0	0	9.3	17.57	56	-38.43	-	-	
16	.6795	-6.41	Ca	0	0	9.3	2.89	-	-	46	-43.11	
17	.97875	7.45	Qp	0	.1	9.3	16.85	56	-39.15	-	-	
18	.97875	-7.23	Ca	0	.1	9.3	2.17	-	-	46	-43.83	
19	4.572	9.91	Qp	0	.1	9.3	19.31	56	-36.69	-	-	
20	4.572	-3.92	Ca	0	.1	9.3	5.48	-	-	46	-40.52	

Qp - Quasi-Peak detector
 Ca - CISPR average detection

LINE 2 RESULTS

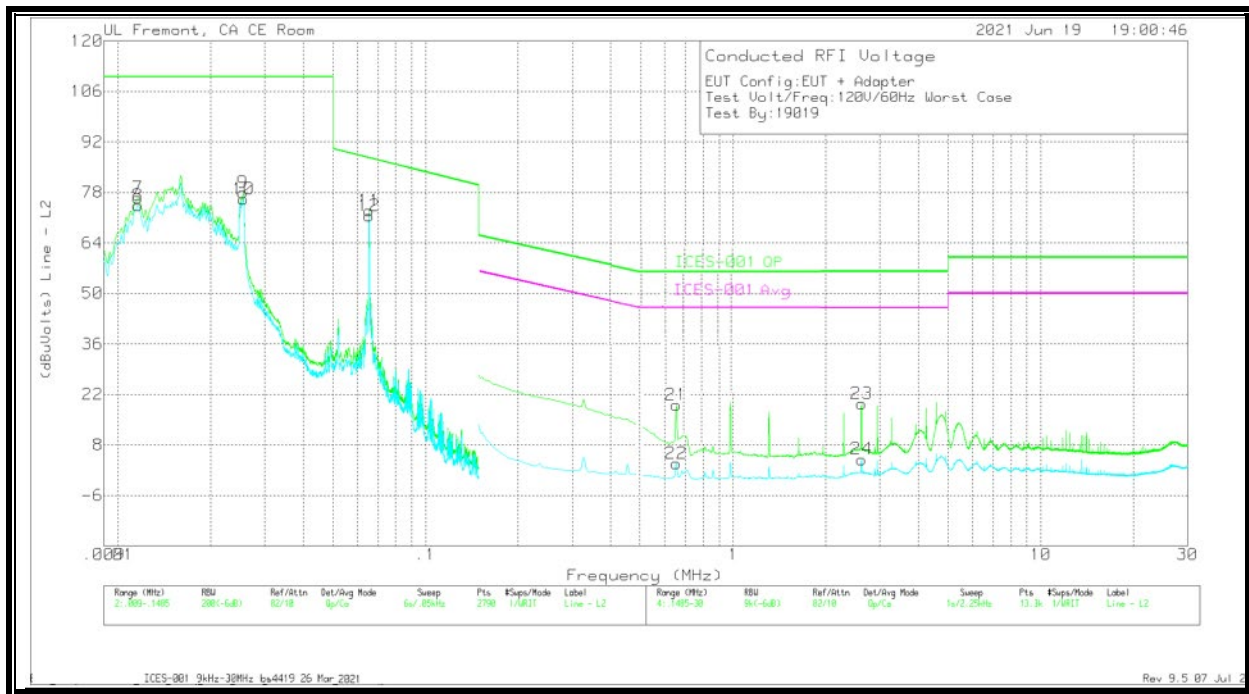

WORST EMISSIONS

Range 2: Line - L2 .009 - 30MHz											
Marker	Frequency (MHz)	Meter Reading (dBuV)	Det	PRE0186446 LISN10(IL L2)_r	LC Cables C2&C3 dB	TekBox Limiter TBFL1 Model 207	Corrected Reading (dBuVolts)	ICES-001 Class QP	Margin (dB)	ICES-001 Class B Avg	Margin (dB)
7	.01163	60.42	Qp	3.7	0	12.4	76.52	110	-33.48	-	-
8	.0116	58.13	Ca	3.8	0	12.4	74.33	-	-	-	-
9	.0255	64.77	Qp	1.1	0	12	77.87	110	-32.13	-	-
10	.02555	63.09	Ca	1.1	0	12	76.19	-	-	-	-
11	.0655	61.97	Qp	.2	0	10.8	72.97	87.52	-14.55	-	-
12	.0655	60.6	Ca	.2	0	10.8	71.6	-	-	-	-
21	.6525	9.75	Qp	0	0	9.3	19.05	56	-36.95	-	-
22	.6525	-6.38	Ca	0	0	9.3	2.92	-	-	46	-43.08
23	2.61225	10.07	Qp	0	.1	9.3	19.47	56	-36.53	-	-
24	2.61225	-5.4	Ca	0	.1	9.3	4	-	-	46	-42

Qp - Quasi-Peak detector
 Ca - CISPR average detection

9.1.2. OPERATING MODE (1.778MHz) WITH WATCH POWERED BY AC/DC ADAPTER

LINE 1 RESULTS

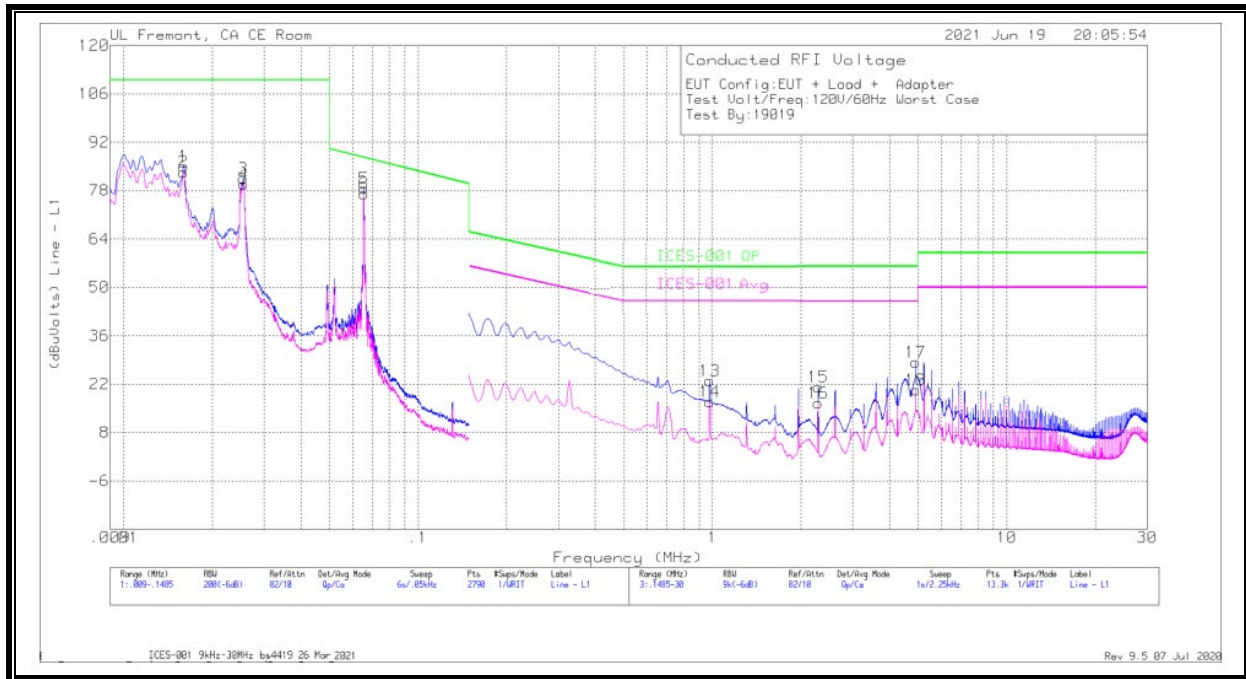

WORST EMISSIONS

Range 1: Line - L1 .009 - 30MHz											
Marker	Frequency (MHz)	Meter Reading (dBuV)	Det	PRE0186446 LISN09(IL L1)_r	LC Cables C1&C3 dB	TekBox Limiter TBFL1 Model 207	Corrected Reading (dBuVolts)	ICES-001 Class QP	Margin (dB)	ICES-001 Class B Avg	Margin (dB)
1	.016	70.4	Qp	2.4	0	12.3	85.1	110	-24.9	-	-
2	.01595	68.69	Ca	2.4	0	12.3	83.39	-	-	-	-
3	.0255	68.41	Qp	1.1	0	12	81.51	110	-28.49	-	-
4	.02555	66.84	Ca	1.1	0	12	79.94	-	-	-	-
5	.0655	67.65	Qp	.2	0	10.8	78.65	87.52	-8.87	-	-
6	.06555	66.15	Ca	.2	0	10.8	77.15	-	-	-	-
13	.97875	13.55	Qp	0	.1	9.3	22.95	56	-33.05	-	-
14	.97875	7.58	Ca	0	.1	9.3	16.98	-	-	46	-29.02
15	2.286	11.81	Qp	0	.1	9.3	21.21	56	-34.79	-	-
16	2.286	7.24	Ca	0	.1	9.3	16.64	-	-	46	-29.36
17	4.89825	19.03	Qp	0	.1	9.3	28.43	56	-27.57	-	-
18	4.89825	10.98	Ca	0	.1	9.3	20.38	-	-	46	-25.62

Qp - Quasi-Peak detector
 Ca - CISPR average detection

LINE 2 RESULTS

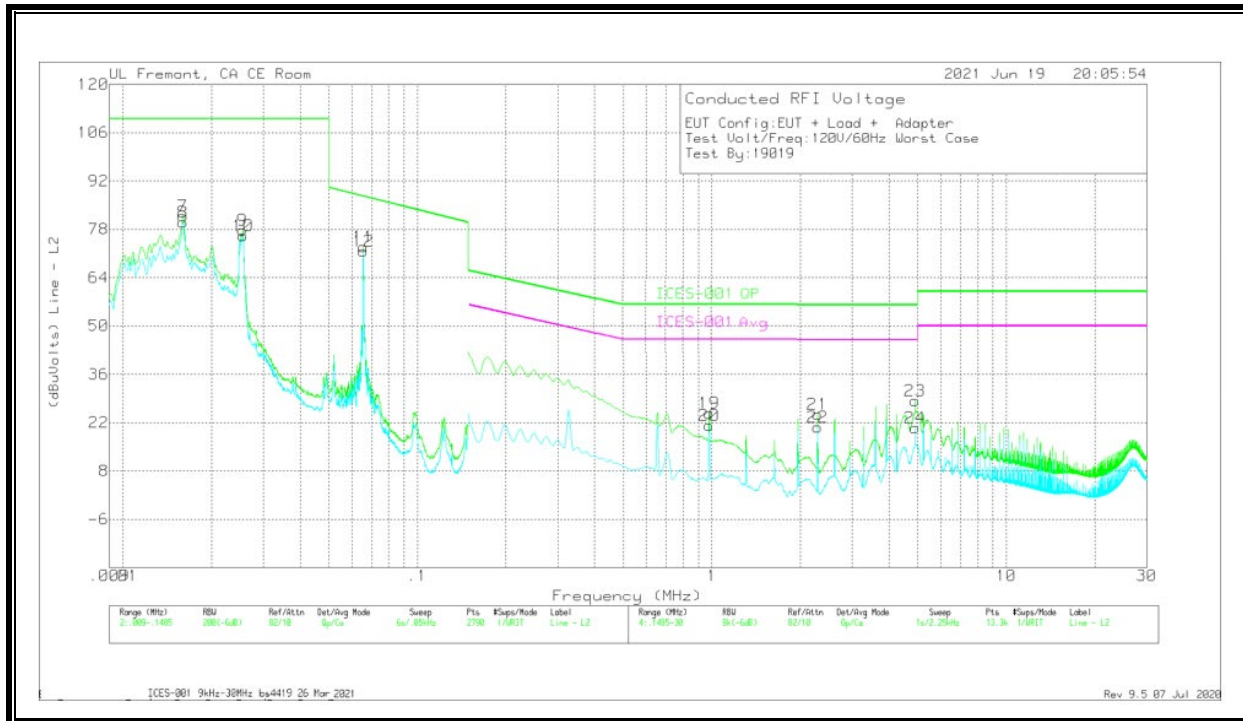

WORST EMISSIONS

Range 2: Line - L2 .009 - 30Hz											
Marker	Frequency (MHz)	Meter Reading (dBuV)	Det	PRE0186446 LISN10(IL L2) r	LC Cables C2&C3 dB	TekBox Limiter TBFL1 Model 207	Corrected Reading (dBuVolts)	ICES-001 Class QP	Margin (dB)	ICES-001 Class B Avg	Margin (dB)
7	.016	67.18	Qp	2.4	0	12.3	81.88	110	-28.12	-	-
8	.016	65.31	Ca	2.4	0	12.3	80.01	-	-	-	-
9	.0255	64.59	Qp	1.1	0	12	77.69	110	-32.31	-	-
10	.02555	63.02	Ca	1.1	0	12	76.12	-	-	-	-
11	.0655	62.02	Qp	.2	0	10.8	73.02	87.52	-14.5	-	-
12	.06555	60.63	Ca	.2	0	10.8	71.63	-	-	-	-
19	.97875	15.3	Qp	0	.1	9.3	24.7	56	-31.3	-	-
20	.97875	11.78	Ca	0	.1	9.3	21.18	-	-	46	-24.82
21	2.286	14.95	Qp	0	.1	9.3	24.35	56	-31.65	-	-
22	2.286	11.35	Ca	0	.1	9.3	20.75	-	-	46	-25.25
23	4.89825	18.88	Qp	0	.1	9.3	28.28	56	-27.72	-	-
24	4.89825	11.04	Ca	0	.1	9.3	20.44	-	-	46	-25.56

Qp - Quasi-Peak detector
 Ca - CISPR average detection

9.1.3. OPERATING MODE (326.5kHz) WITH WATCH POWERED BY AC/DC ADAPTER

LINE 1 RESULTS

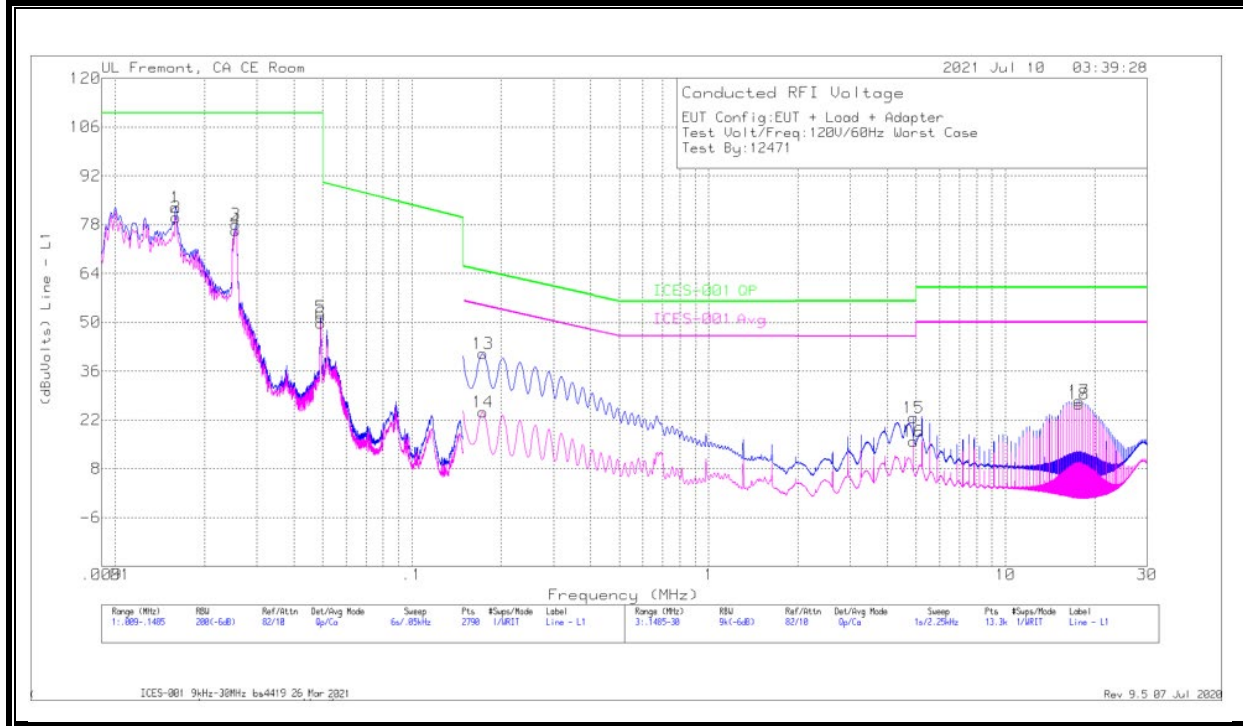

Range 1: Line - L1 .009 - .1485MHz											
Marker	Frequency (MHz)	Meter Reading (dBuV)	Det	PRE0186446 LISN09(IL L1) r	LC Cables C1&C3 dB	TekBox Limiter TBFL1 Model 207	Corrected Reading (dBuVolts)	ICES-001 Class QP	Margin (dB)	ICES-001 Class B Avg	Margin (dB)
1	.016	68.27	Qp	2.4	0	12.3	82.97	110	-27.03	-	-
2	.01605	65.49	Ca	2.3	0	12.3	80.09	-	-	-	-
3	.0255	64.96	Qp	1.1	0	12	78.06	110	-31.94	-	-
4	.0255	63.33	Ca	1.1	0	12	76.43	-	-	-	-
5	.04925	39.88	Qp	.4	0	11.3	51.58	110	-58.42	-	-
6	.04925	38.06	Ca	.4	0	11.3	49.76	-	-	-	-

Range 3: Line - L1 .1485 - 30MHz											
Marker	Frequency (MHz)	Meter Reading (dBuV)	Det	PRE0186446 LISN09(IL L1) r	LC Cables C1&C3 dB	TekBox Limiter TBFL1 Model 207	Corrected Reading (dBuVolts)	ICES-001 Class QP	Margin (dB)	ICES-001 Class B Avg	Margin (dB)
13	.17325	31.55	Qp	0	0	9.4	40.95	64.73	-23.78	-	-
14	.17325	14.92	Ca	0	0	9.4	24.32	-	-	54.8	-30.48
15	4.89825	13.3	Qp	0	.1	9.3	22.7	56	-33.3	-	-
16	4.89825	6.42	Ca	0	.1	9.3	15.82	-	-	46	-30.18
17	17.63325	17.91	Qp	0	.2	9.3	27.41	60	-32.59	-	-
18	17.63325	17.02	Ca	0	.2	9.3	26.52	-	-	50	-23.48

LINE 2 RESULTS

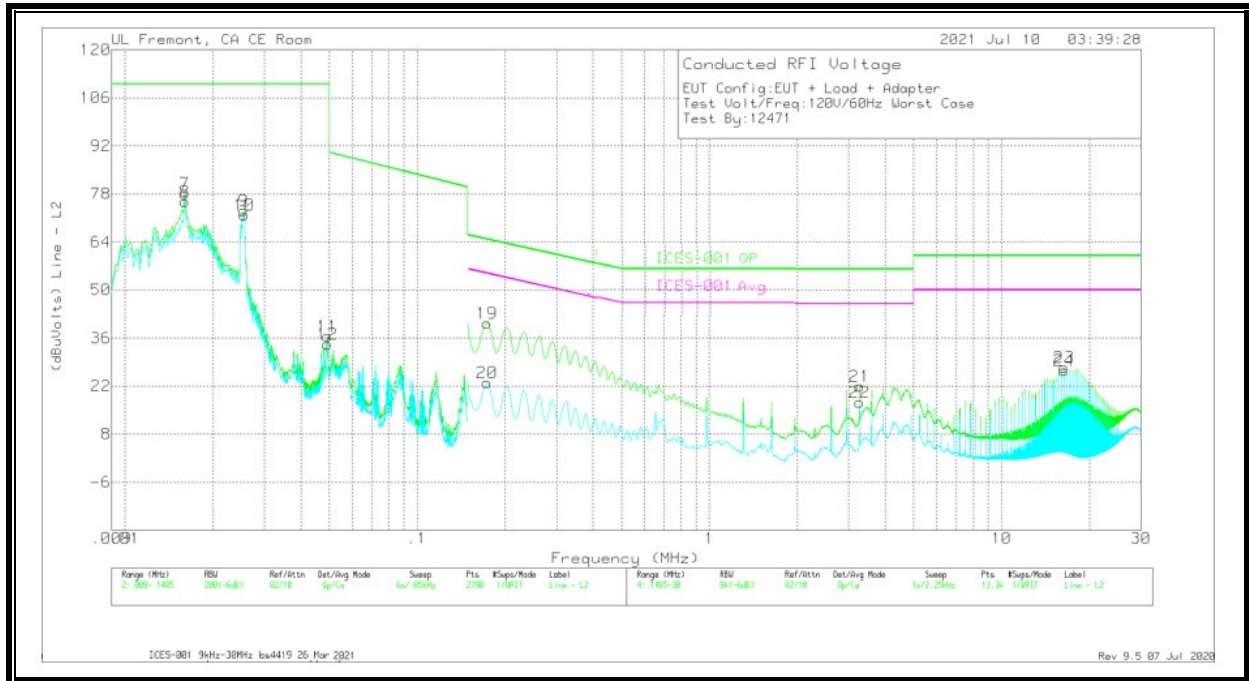

Range 2: Line - L2 .009 - .1485MHz											
Marker	Frequency (MHz)	Meter Reading (dBuV)	Det	PRE0186446 LISN10(IL L2) r	LC Cables C2&C3 dB	TekBox Limiter TBFL1 Model 207	Corrected Reading (dBuVolts)	ICES-001 Class QP	Margin (dB)	ICES-001 Class B Avg	Margin (dB)
7	.01605	63.53	Qp	2.3	0	12.3	78.13	110	-31.87	-	-
8	.01605	61.13	Ca	2.3	0	12.3	75.73	-	-	-	-
9	.0255	60.1	Qp	1.1	0	12	73.2	110	-36.8	-	-
10	.02555	58.7	Ca	1.1	0	12	71.8	-	-	-	-
11	.04925	24.95	Qp	.3	0	11.3	36.55	110	-73.45	-	-
12	.04925	22.66	Ca	.3	0	11.3	34.26	-	-	-	-
Range 4: Line - L2 .1485 - 30MHz											
Marker	Frequency (MHz)	Meter Reading (dBuV)	Det	PRE0186446 LISN10(IL L2) r	LC Cables C2&C3 dB	TekBox Limiter TBFL1 Model 207	Corrected Reading (dBuVolts)	ICES-001 Class QP	Margin (dB)	ICES-001 Class B Avg	Margin (dB)
19	.17325	30.92	Qp	0	0	9.4	40.32	64.73	-24.41	-	-
20	.17325	13.63	Ca	0	0	9.4	23.03	-	-	54.8	-31.77
21	3.26475	12.59	Qp	0	.1	9.3	21.99	56	-34.01	-	-
22	3.26475	7.87	Ca	0	.1	9.3	17.27	-	-	46	-28.73
23	16.326	17.92	Qp	0	.2	9.3	27.42	60	-32.58	-	-
24	16.326	17.08	Ca	0	.2	9.3	26.58	-	-	50	-23.42

10. SETUP PHOTO

Please refer to 13573888-EP1V1 for setup photos

END OF TEST REPORT